

# PHYSICS PAPER 3 KCSE PAST PAPERS(2005-2016)

For marking schemes, call/Whatsapp-0746711892



'an investment of knowledge pays

The following KASNEB notes are available;

 ATD

 CPA

 CS

 CIFA

Call Mdm.Mariam;0746711892 to acquire them



# PHYSICS PAPER 3 ( 232/3)

## PRACTICAL QUESTIONS

### PAPER 3

OCT/NOV. 2005

1. This question has two parts A and B. Answer both parts.

#### PART A

You are provided with the following:

- a metre rule
- knife edge raised 20 cm above bench
- one 50 g mass and one 100 g mass
- a beaker or any container
- some thread
- some water in a beaker
- Liquid L in a beaker
- tissue paper

Proceed as follows:

- a) Balance the metre rule edge and record the reading at this point

Balance point = ..... cm (1cm)

*For the rest of this experiment the knife edge must be placed at this position*

- b) Set up the apparatus as shown in figure 1. Use the thread provided to hang the masses such that the positions of support can be adjusted.

The balance is attained by adjusting the position of the 100g mass. Note that the distance  $x$  and  $D$  are measured from the knife edge and the 50g mass is fully submerged in the water.

Record the values of X and D.

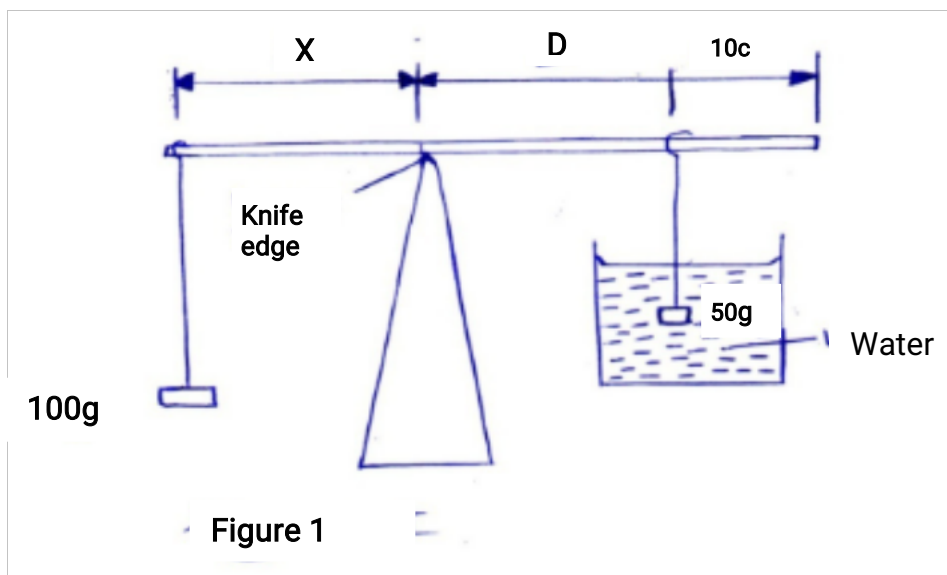

X=.....cm (1 mk)

D=.....Cm (1 mk)

Apply the principle of moments to determine the weight  $W_1$  of the 50 g mass in water and hence determine the up thrust  $U_w$  in water

$W_1$ ..... N (2mks)

$U_w$ .....N (1 mk)

Remove the 50 g mass from the water and dry it using tissue paper.

(c) Now balance the metre rule when the 50 g mass is fully submerged in the liquid L. Record the value of the distance X.

X=.....cm (1 mk)

Apply the principle of moments to determine the weight  $W_1$  of the 50 g mass in the liquid L and hence determine the upthrust  $U_L$  in the liquid

$W_2$ =..... (1mk)

$U_l$ =..... (1mk)

$$R.D = \frac{U_l}{U_w}$$

## PART B

You are provided with the following:

- a rectangular glass block
- four optical pins
- a piece of soft board
- a plain sheet of paper
- Sellotape

You are also required to have your complete mathematical set. Proceed as follows:

- (e) Place the plain sheet of paper on the soft board and fix it using the Sellotape provided. Place the glass block at the centre of the sheet, and draw its outline. Remove the glass block. (See figure 2).

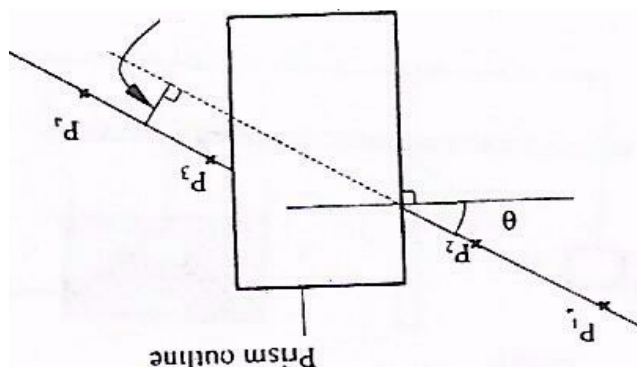

- e) Draw a normal line at a point 2 cm from the end of one of the longer side of the block outline. This normal line will be used for the rest of this experiment.

Draw a line at an angle  $\theta = 25^\circ$  from the normal. Stick two pins  $P_1$  and  $P_2$  vertically on this line.

- g) By viewing through the glass from the opposite side stick two other pins  $P_3$  and  $P_4$  vertically

such that they are in line with the images of the first two pins. Draw a line through the

marks made by  $P_3$  and  $P_4$  to touch the outline.  
 Extend the line  $P_1P_2$  through the outline (dotted line).  
 Measure and record in table 2 the perpendicular distance  $d$  between the extended line and the line  $P_3P_4$ . (See figure 2).  
*Record this value in table 1*

h) Repeat the procedure in (f) and (g) for other values of  $\theta$  shown in table L

NB. The sheet of paper with the drawing must be handed in together with this question paper. Ensure you write your name and index number on the sheet of paper.

$\theta$ (deg)	25	35	40	45	55	60	65
$d$ (cm)							

f) On the grid provided, plot a graph of  $d$  (y-axis) against  $\theta$

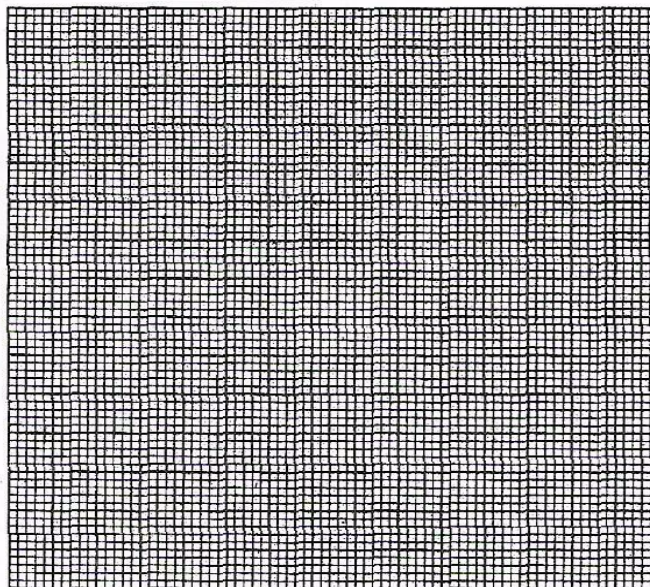

*Using the graph, estimate the value of  $d$  when  $\theta=0^\circ$ .*

(2 mk)

2.0 You are provided with the following:

*For marking schemes, call/Whatsapp-0746711892*

- two wires, one labelled T and the other S each mounted on a piece of wood.
- a dry cell and a cell holder
- a wire w mounted on a mm scale
- a jockey
- a centre zero galvanometer
- connecting wires (some with crocodile clips)
- a micrometer screw gauge (to be shared)
- a metre rule or a half metre rule
- a switch

Proceeds as follows

a) Determine the average diameter  $D$  of the wire labeled T and the average diameter,  $d$ , of the wire labeled S using the micrometer screw gauge provided

$D = \dots\dots\dots \text{mm}$  (1mk)

$d = \dots\dots\dots \text{mm}$  (1 mk)

Calculate  $\frac{D}{d} = \dots\dots\dots$  (1mk)

(b) Set up the apparatus as shown in the circuit diagram in figure 3.

Use crocodile clips to fix the lengths of T and S at 50 cm each initially. This length of T will not be changed throughout the experiment

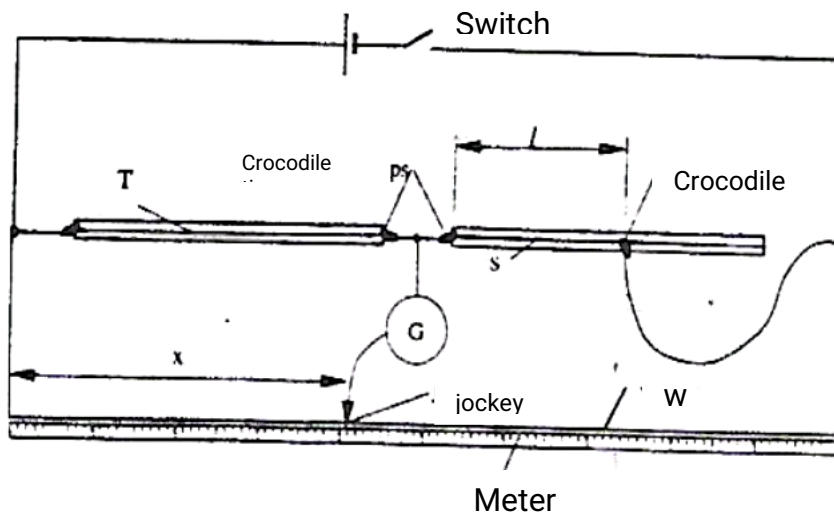

c) Close the switch. Use the jockey to touch one end of the wire W and then the other end. The

deflections on the galvanometer should be in the opposite directions if not, check

the circuit.

Adjust the position of the jockey along the wire W until there is no deflection in the galvanometer this is the balance point. Record the value of X in cm in the table

d) Adjust the length of wire S to 45 cm. Find the balance point and record the value of X in the table. Repeat for other values of  $\ell$  in the table. Complete the table.

(6 mks)

Table 3

$\ell$ (cm)	50	45	40	35	30	25	20
X (cm)							
$\frac{1}{X}$ (cm <sup>-1</sup> )							

d i) Plot the graph of  $1/X$  (y – axis ) against

ii) Determine the slope m of the graph

(3 mks)

iii) Determine the ratio D/d given that  $M = \frac{D^2}{5000d^2}$

(3mks)

# PHYSICS PAPER 3 ( 232/3)

## PRACTICAL QUESTIONS

### PAPER 3

OCT/NOV. 2006

#### QUESTION ONE

You are provided with the following:

- a glass marble
- a 105 cm plastic tube split open with a mark near one end
- vernier callipers (to be shared)
- a metre rule or half-metre rule
- a balance (to be shared)
- retort stand, one boss and one clamp.

Proceed as follows:

- (a) Use the vernier callipers provided to measure the diameter of the marble and hence determine the radius.

Diameter of the marble = .....cm  
Radius of the marble  $r$  = .....cm

- (b) (i) Using the balance provided obtain the mass  $M$  of the marble,
- (ii) Determine the constant  $P$  given that  $P = 0.4 Mr^2$ . The experiment involves timing a marble as it runs down the split tube as a runway.

- (c) Clamp the marked end of the split tube with the inside uppermost. Ensure the end with



the mark is on the greater slope. Raise this end such that the mk is at a height  $h = 8 \text{ cm}$  above the bench level. The other end should rest on the bench as shown in figure 1

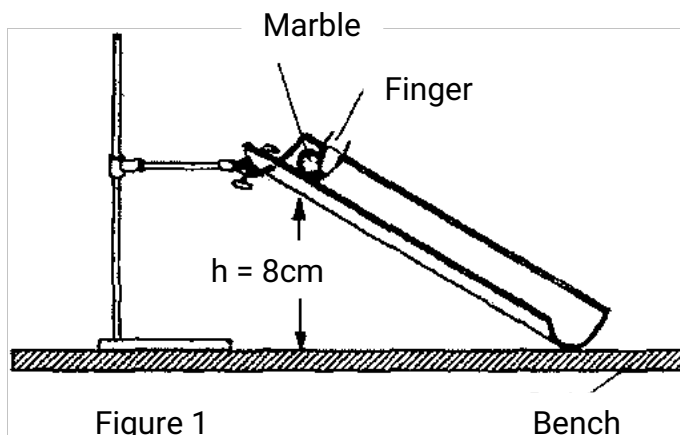

Place the marble at the mark on the runway and hold it in place gently with the finger as shown in the figure 1. By simultaneously releasing the ball and starting the stop watch measure and record in table 1, the time,  $t$  taken by the marble to reach the lower end of the runway, at is advisable to measure the time twice and record the average value).

Vary the height  $h$ , to other values shown in table 1. Measure and record in the table the corresponding average, values of  $t$ . Complete the table.

TABLE 1

height, $h$	s	9	10	11	12	13	14	15.
Average								
$t^2(s^2)$								
$1/h \text{ (cm}^{-1}\text{)}$								

- (d) (f) On the grid provided plot the graph of  $t^2$  (y-axis) against
- (it) DETERMINE the **slope S** of fee graph.
- (iii) Determine the constant  $G$  for the marble given that  $G = Mr^2\left(\frac{S}{20}-1\right)$

### QUESTION TWO

You are provided with the following

A voltmeter

Two dry cells and a cell holder

A switch

A resistor labeled ( $4\Omega$ )

A wire mounted to scale and labeled  $G$

A micrometer screw gauge (to be shared)  
 Six connecting wires with six crocodile clips  
 Proceed as follows;

a) Record the length  $L_0$  of the wire labeled G.

$L_0 = \dots\dots\dots$

Use the micrometer screw gauge provided to measure the diameter of the wire labelled G at two different points and determine the average diameter, d

The diameter  $d_1 = \dots\dots\dots$ mm,  $d_2 = \dots\dots\dots$ mm

Average diameter  $d = \dots\dots\dots$ mm

Determine the radius r of the wire in metres

Radius  $r = \dots\dots\dots$ m

b) Set up the apparatus as shown in the circuit diagram in figure 2

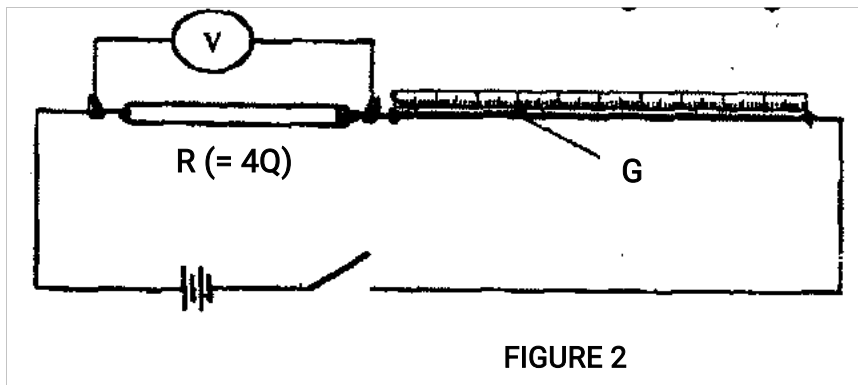

FIGURE 2

i) Use the voltmeter provided to measure the p.d,  $V_R$  across R and the p.d,  $V_G$  across G when the switch is closed

$V_R = \dots\dots\dots$ volts

$V_G = \dots\dots\dots$ Volts

Open the switch

ii) Use the value of R provided and the value of  $V_R$  in b (i) above to calculate the current I flowing through R when the switch was closed.

$I = \dots\dots$ Amperes

iii) Determine the constant H given that

$$H = \frac{100V_G}{I \times L_0}$$

$$H = \dots \Omega \text{m}^{-1}$$

c) Connect the voltmeter across R as shown in figure 3.

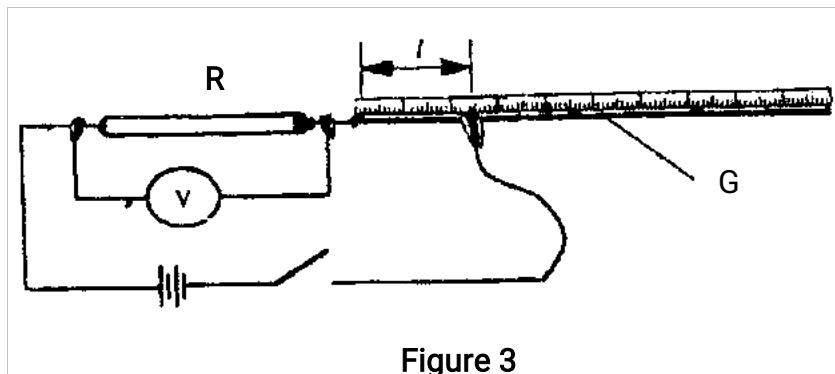

Adjust the position of one crocodile clip on the wire G to a point such that the length  $l$  of the wire in the circuit is 5 cm. (see figure 3) close the switch  
Read and record in table 2, the value of the p.d across R. Open the switch

d) Repeat the procedure in (c) above for the other values of  $l$  shown in table 2

**Table 2**

distance $l$ (cm)	0	5	10	20	30	40	60
pd. V across R (V)							

e) i) On the grid provided plot the graph of  $V$  (y – axis) against  $l$ .

ii) From the graph, determine  $l_1$  the value of  $l$  when  $v = \frac{V_0}{2}$  where  $V_0$  is the p.d. where  $l = 0$ .

f) Determine the constant  $D$  for the wire given that

$$D = \frac{R \times 300}{l_1 V_0}$$

g) Determine the constant  $p$  given that

$$p = \frac{\pi r^2}{2} (D + H), \text{ where } r \text{ is the radius of the wire in metres}$$

## PHYSICS PAPER 3 ( 232/3)

### PRACTICAL QUESTIONS

### PAPER 3

OCT/NOV. 2007

1. You are provided with the following;

- a metre rule,
- an optical pin fixed to a piece of cork.
- two retort stands, two bosses and two clamps.
- two wooden blocks.
- a stop watch.
- some thread tied to a mass.

Proceed as follows;

- (a) Set up the apparatus as shown in figure 1.

**Wooden  
blocks**

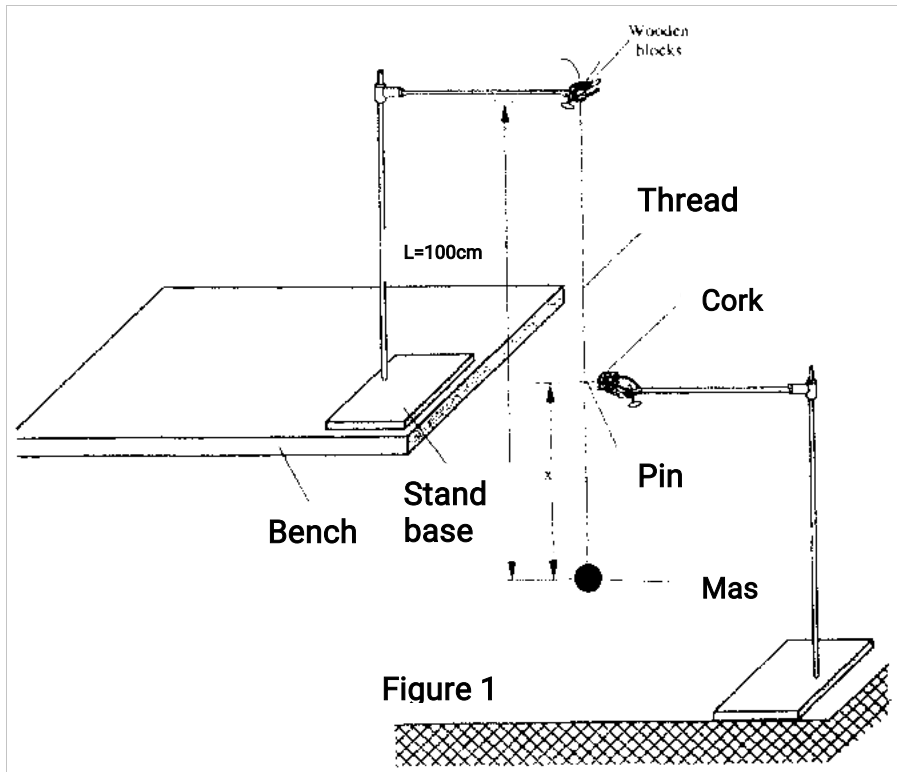

The thread tied to the mass should be held firmly between the two blocks of wood and clamped to the upper end of the stand so that the mass hangs freely. The distance  $L$  between the point of support and the centre of the mass is 100 cm. **Ensure that  $L$  remains constant throughout the experiment**

Adjust the lower clamp so that the optical pin just touches the thread when the hanging mass is at rest.

- (b) Adjust the position of the lower stamp so that the pin is at a distance  $X = 35$  cm Above the centre of the mass. Displace the mass slightly to one side and release it so that it. Swings in a plane perpendicular to the pin and the thread hits the pin as shown in **Figure 2.**

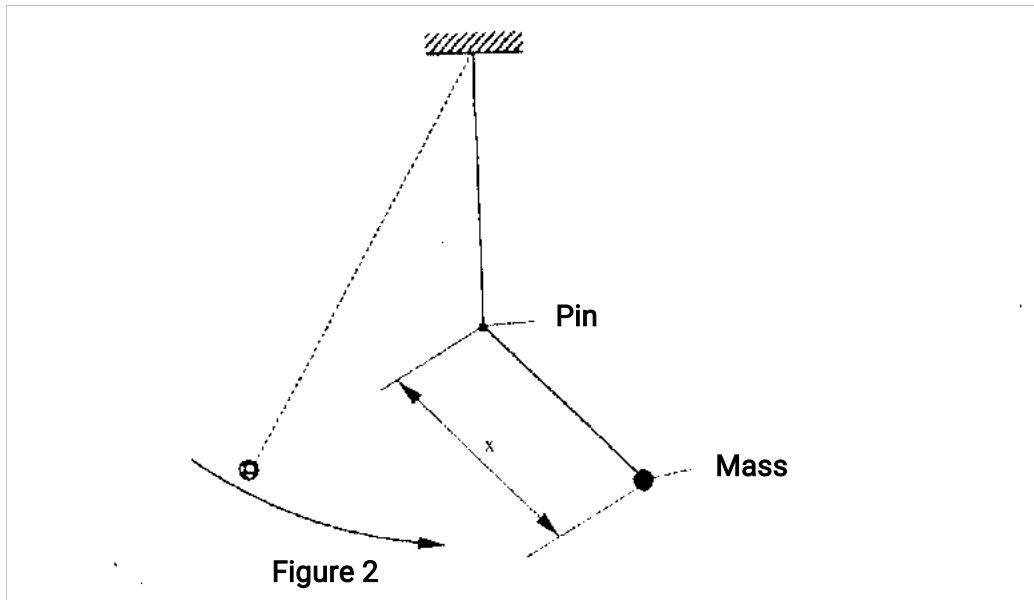

Measure and record in table 1 the time  $t$  for 20 oscillations.

- (c) Repeat the procedure in (b) for other values of  $X$  shown in table 1.  
Complete the table,

**Table 1**

Distance $X$ (cm)	35	40	45	50	55'	60
Time $t$ for 20 osc (s)						
$T = \frac{t}{20}$ (s)						

On the grid provided

- d) plot the graph of  $T$  (Y – axis ) against  $X$   
(5 mks)

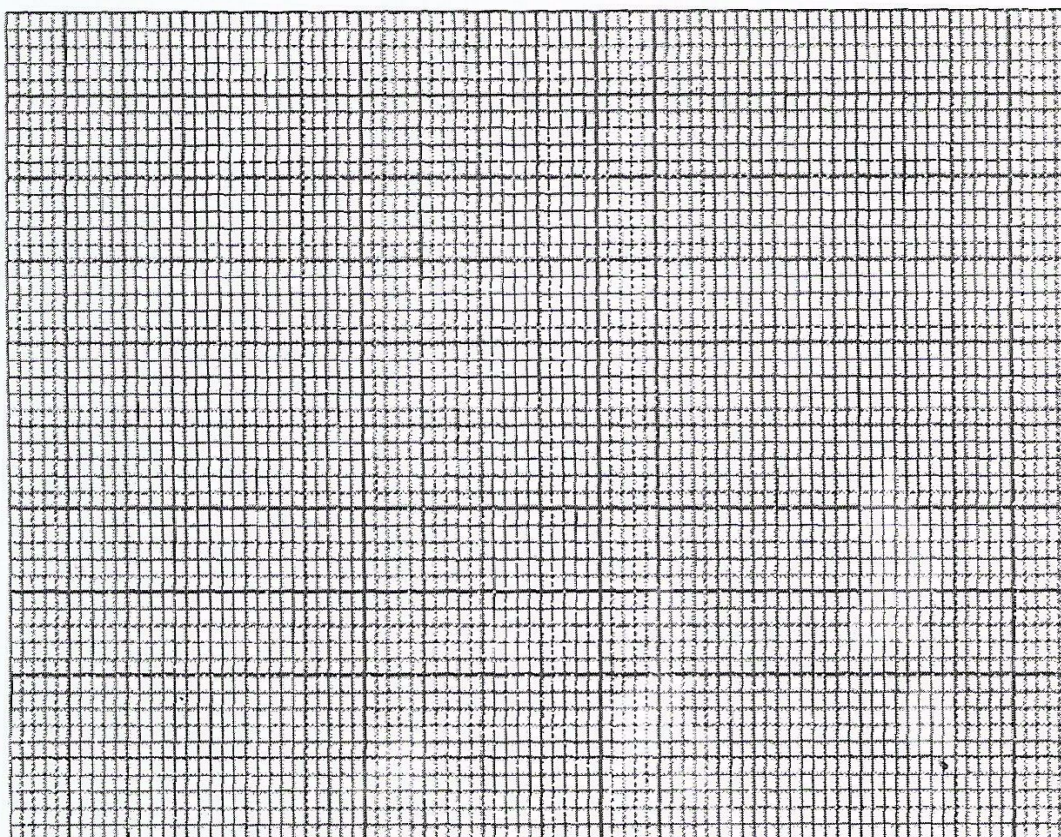

e) Determine the slope  $S$  of the graph at appoint  $X = 52 \text{ cm}$

(3mks)

f) Determine eh constant  $n$  given that  $n = 52 S^2$

(2 mks)

g) Determine the constant  $P$  given that  $P = \frac{\pi^2}{4n}$

(2 mks)

2. You are provided with the following

A voltmeter

Two cells and a cell holder

A switch

A set of six resistors each of resistance  $1000\Omega$

Connecting wires

Proceed as follows

a) Set up the apparatus as shown in the circuit diagram in figure 3.

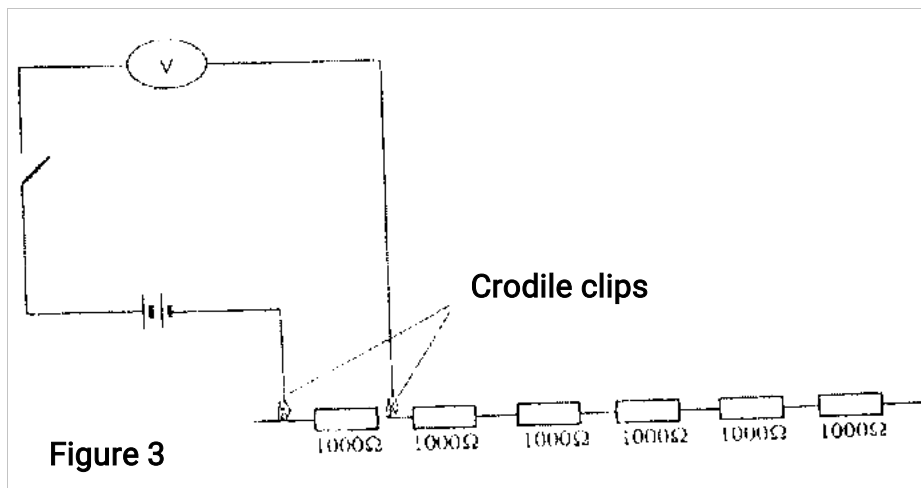

B i) Record the voltmeter reading  $E$ , when the crocodile clips are connected together ( $R=0$ )

$E = \underline{\hspace{2cm}}$  Volt (1 mk)

Open the switch and separate the crocodile clips

Indicate by ticking below, the range of the voltmeter used

0-3v     0-5 v     0-15v

ii) Now connect the crocodile clips across resistance  $R= 1000\Omega$  . close the switch and record in table 2 the voltmeter reading  $V$ . Open the switch.

c) Repeat the procedure in bii) for other values of resistance  $R$  shown in the table.

Complete the table

**Table 2**

resistance	1000	2000	3000	4000	5000	6000
$R\Omega$						
$V(v)$						
$1/v (v^{-1})$						



d) On the grid provided plot the graph of R (y axis) against I/V

(5 mks)

Hint: draw your axes to include point (0,0) half way up the page ie the I/V axis to run across the middle of the page

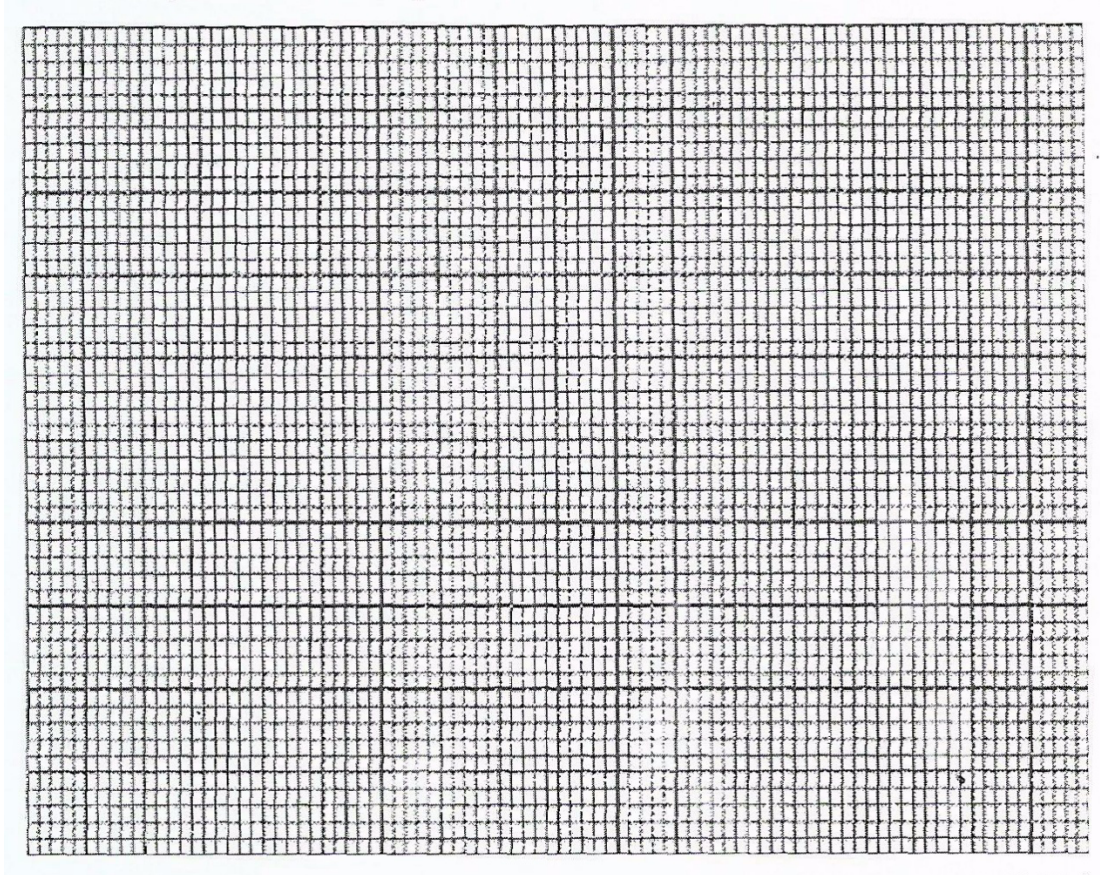

e) Determine the slop S of the graph

(3 mks)

f) Determine the constant G given that  $G = S/E$

( 2 mks)

g) From the graph determine

i)  $V_0$ , the value of V when R = 0

(1 mk)

# PHYSICS PAPER 3 ( 232/3)

## PRACTICAL QUESTIONS

### PAPER 3

OCT/NOV. 2008

#### QUESTION 1

*This question consists of Two parts A and B. Attempt both parts.*

##### Part A

You are provided with the following:

- o copper wire
- o a retort stand, boss and clamp
- o an optical pin mounted on a cork
- o a stop watch
- o wire cutters (to be shared)
- o a metre rule or half metre rule

Proceed as follows:

- (a) Clamp the cork so that the optical pin is horizontal. Hang the copper wire from the pin by the loop as shown in figure 1. Ensure the wire is straight and the length  $X$  between the lower tip and the optical pin is 32 cm. If the length exceeds 32 cm reduce by cutting at the lower tip using the wire cutters provided.

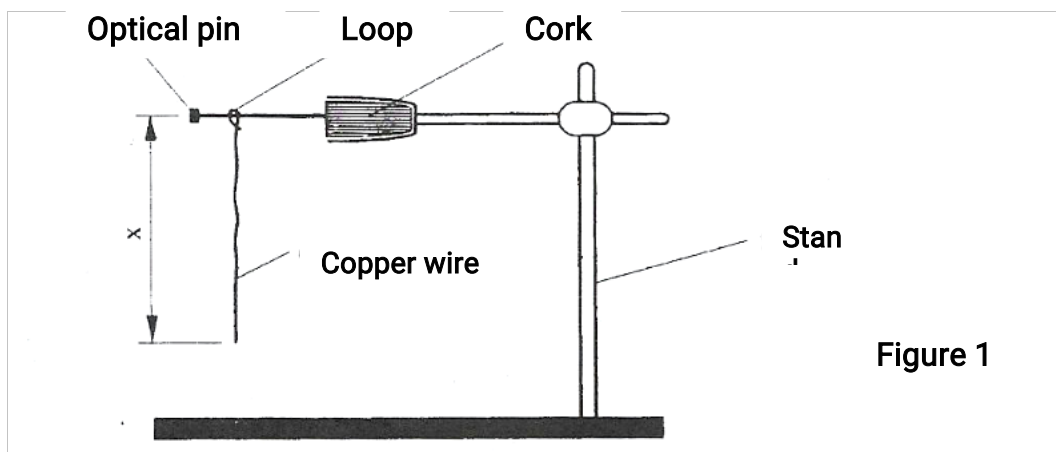

- (b) Displace the lower tip of the wire slightly in a plane perpendicular to the

optical pin and then release it. Measure the time  $t$  for 20 oscillations of the wire and record the value in table 1.

- (c) Repeat the procedure in (b) above for other values of  $X$  shown in the table. (Note that each length  $X$  is obtained by cutting off an appropriate length from the lower tip of the wire. For example to get  $X = 28$  cm cut off 4 cm from the lower end). Complete the table.

**Table 1**

Length $X$ (cm)	32	28	24	20	16	12
time $t$ for 20 oscillations (s)						
Period $T = t/20$ (s)						
$T^2$ (s <sup>2</sup> )						

- d) Plot a graph of  $T^2$  (y – axis) against  $x$   
(5 mks)

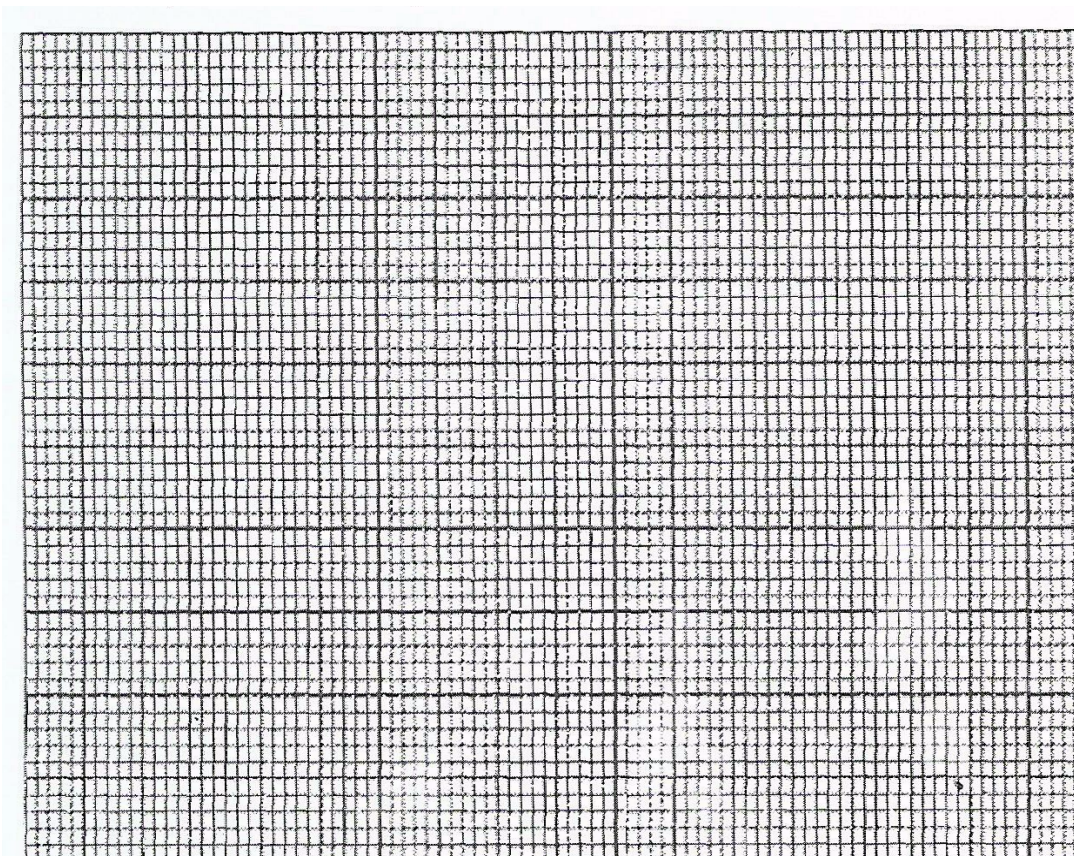

- e i) Determine the slope,  $S$ , of the graph

(3 mks)

ii) Obtain the value of  $k$  in the equation  $S = \frac{8\pi}{3k}$

(2 mks)

### PART B

You are provided with the following:

- a cylindrical container
- some water
- a stop watch
- a metre rule or half-metre rule
- a boiling tube
- some sand
- a rubber band

Proceed as follow;

Tie the rubber band round the boiling tube so that it is at a distance  $L = 12$  cm from the bottom of the tube (see fig 2a). Pour water into the cylindrical container until the level is about 2.0 cm from the top of the beaker. Float the boiling tube in the water in the container. Add sand gradually into the boiling tube until the tube sinks to the 12 cm mark. See figure 2(b).



(g) Depress the boiling tube slightly and release so that it oscillates vertically without touching the sides of the container. Measure and record in table 2 the time  $t$ , for five oscillations of the boiling tube. Repeat the procedure two more times to obtain  $t_r$  and  $t$ , and record the values in table 2. Complete the table.

T1(s)	T3(s)	T3(s)	Average t(s) $t = \frac{t_1+t_2+t_3}{3}$	$T = \frac{t}{5}$ (s)

h) Evaluate  $p = \frac{40L}{T^2}$  given that L is the length of the tube upto the rubber band in (f) and T is the value obtained in (g) above.

### Question 2

*This question consists of two parts; A and B.*

*Attempt both parts.*

#### PART A

You are provided with the following:

- a triangular glass prism
- a piece of soft board
- four (4) optical pins
- a sheet of plain paper.

Proceed as follows:

- (a) Place the plain sheet of paper on the soft board. Trace the triangular outline of the prism on the sheet of paper. Remove the prism and use a ruler to extend the three sides of the outline. See figure 3(a).

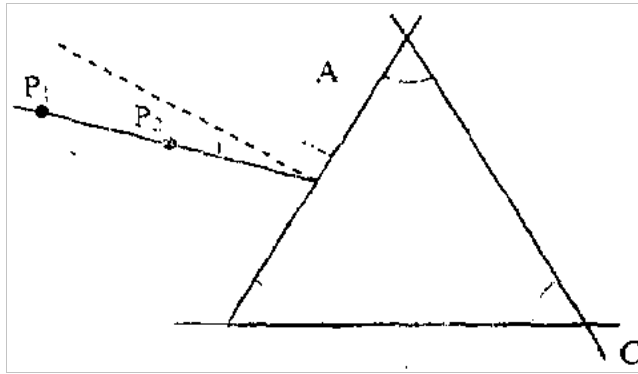

Use a protractor to measure the refracting, angle  $R$ . of the prism.

(b) On the side  $AB$  of the triangular outline, draw a normal at a point half-way between  $A$  and  $B$ . *This normal will be used for that part of this experiment.*

(c) Draw a line at an angle  $i=30^\circ$  to the normal. Stick two pins  $P_1$  and  $P_2$  vertically on this line. See figure 3(a).

(5 mks)

(d) Place the prism accurately on the outline. By viewing through the prism from side  $AC$  stick two other pins  $P_3$  and  $P_4$  vertically such that they are in line with the images of pins  $P_1$  and  $P_2$ . Remove the prism and the pins. Draw a line joining marks made by  $P_3$  and  $P_4$ . Extend this line to meet  $AC$ . (See figure 3(b)). Measure and record in table 3 the value of angle  $\theta$ .

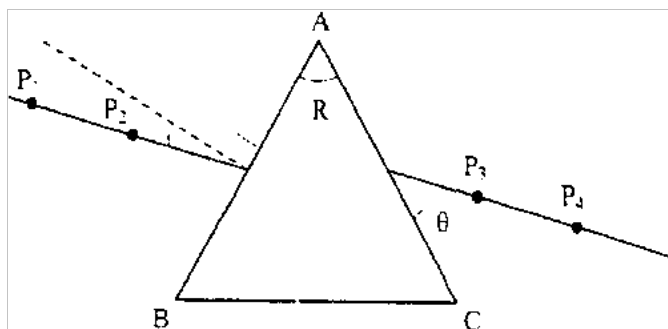

(e) Repeat the procedures in (c) and (d) above for other values of  $i$  shown in table 3. Complete the table.

N.B. ***The sheet of paper with the drawing must be handed in with this question paper. Ensure you write your name and index number on the sheet of paper.***

**Table 3**

Angle of incidence i(deg)	30	35	40	4i	50	55	60
Angle $\theta$ (deg)							
Angle of emergence, E= 90- $\theta$ (deg)							

- (f) (i) On the grid provided plot the graph of the angle of emergence E (y-axis) against the angle of incidence i. (6 mks)
- (5 mks)

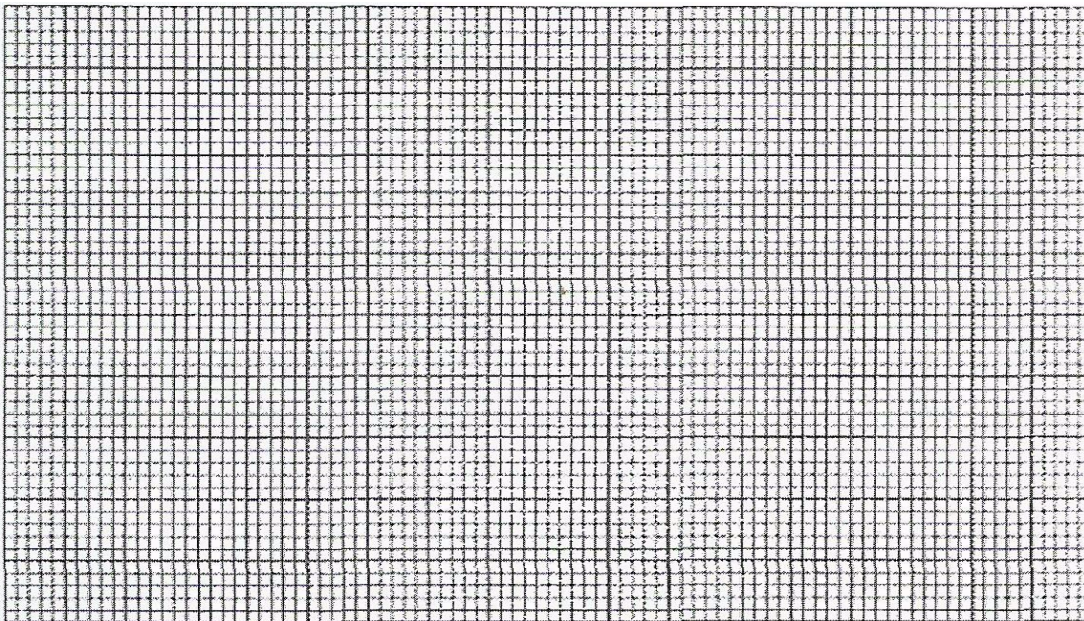

- (ii) Use the graph to find  $i_0$  the angle of incidence at which  $i = E$

(1 mk)

iii) Evaluate

i)  $Y = 2i_0 - R$  (1 mk)

ii)  $b = 2 \sin i_0$  (1 mk)

**PART B**

You are provided with the following:

- a lens and a lens holder
- a screen with .cross-wires
- a candle
- a metre rule

Proceed as follows:

(g) Arrange the lighted candle, the lens and the screen as shown in figure 4.

Adjust the

position of the screen until a sharp inverted image of the candle is formed on the screen.

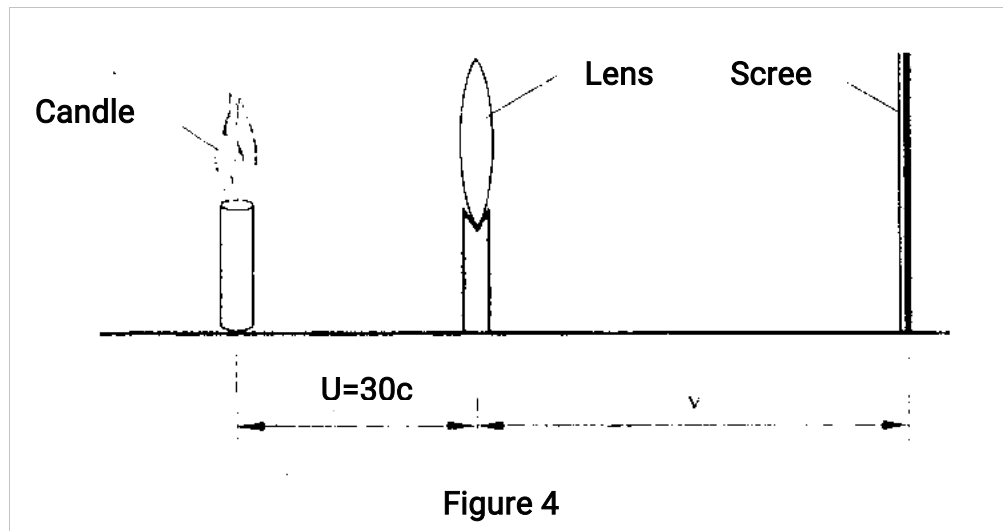

- (i) Measure the image distance  $v$ ,
- (ii) Determine the focal length of the lens using the formula,

$$f = \frac{uv}{u+v}$$

- (h) Now arrange the lighted candle, the screen with cross wires and the lens as shown in figure 5. *Ensure that the centre of the lens, the cross-wires, and the candle flame lie on the same horizontal line.* The candle flame should be placed close to the cross-wires for better illumination



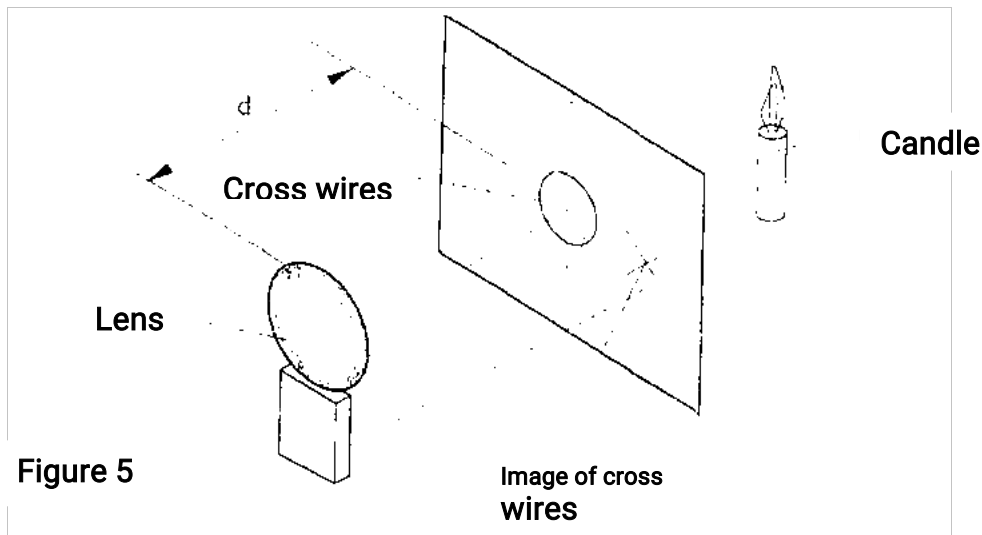

i) Adjust the position of the lens until a sharp image of the cross-wires is formed on the screen next to the crosswires. (*Hint: You may have to rotate the lens slightly about a vertical axis so that the image of the cross-wires falls on the screen next to the cross-wires and not on the cross-wires*).

Measure the distance  $d$ , between the lens and the screen.

$d = \dots\dots\dots$  cm

(1mk)

ii) Evaluate

I.  $L = \frac{df}{f-d}$

(1 mk)

II.  $X = \frac{L}{2F} + 1$

(1 mk)

### PHYSICS PAPER 3 ( 232/3)

## PRACTICAL QUESTIONS

### PAPER 3

OCT/NOV. 2009

1. You are provided with the following:

- two retort stands, two clamps, two bosses
- a stop-watch
- a half metre rule
- a metre rule
- some thread
- some sellotape
- two 50g masses

Proceed as follows:

- (a) Using the two retort stands, set up two simple pendulums each of length 80cm and 46cm apart such that their points of support are in the same horizontal plane.

Ensure that the retort stands are firmly held on the bench. Using the sellotape provided, attach a half-metre rule horizontally on to the strings of the pendulums, such that its upper edge is at a distance  $D = 20\text{cm}$  below the points of suspension. Ensure that the pendulums hang freely without touching the bench.

Figure 1 shows the set up.

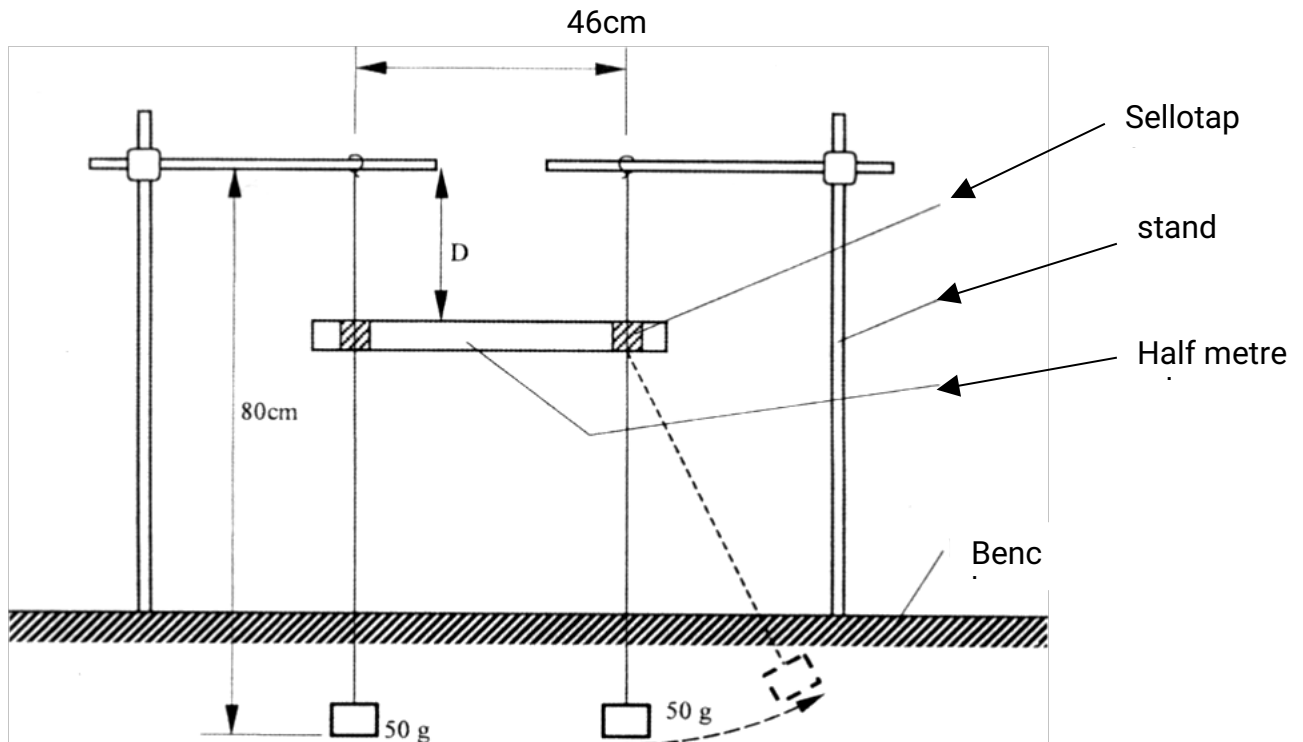

Figure 1

(b) While holding one of the 50g mass of one pendulum, displace the other 50g mass to one side,  
 (see the dotted position in figure 1 and then release both pendulums simultaneously.

(c) Observe the motion of the two masses for about 30 seconds and hence:

(i) describe the pattern of the oscillation of the two masses;

(1 mk)

(ii) state a reason for this pattern in terms of mechanical energy.

(1 mk)

(d) Now focus on any one of the two pendulums.

Measure and record in table 1 the time  $T$  taken for the motion to change from one zero-amplitude state to the next zero-amplitude state. *{Zero-amplitude is when the pendulum is momentarily at rest.}*

(e) Repeat the procedure in (d) for other values of  $D$  shown in table 1

*(Hint:  $D$  can be varied by sliding the half-metre rule down wards along the strings of the pendulums without removing the sellotape.)* Complete the table.

**Do not dismantle the apparatus yet.**

**Table 1**

D(CM)	20	25	30	35	40	45	50
$T(\theta)$							
$f = \frac{1}{T} (s^{-1})$							

(7 mks)

Plot a graph of  $f$  (y axis) against  $D$ .

(5 mks)

(g) Use the graph to determine the frequency  $f_b$  the value of  $f$  when  $D = 38\text{cm}$

$f_b$ .....

(1mk)

(h) Now set the distance  $D$  at 38cm, and repeat the procedure in (b) above.

Measure the time interval  $t$  between two successive zero-amplitudes for pendulum and count the number  $n$  of the oscillations in the interval.

$n =$ ..... (1 mk)

$t =$ ..... (1 mk)

(i) Determine  $f_b$  given that,  $f_0 = \frac{n}{t}$

- (j) Determine  $f_0$  given that  $f_0 = f_1 - f_0$  (1 mk)  
 (2 mks)
- 2 You are provided with the following:

- a voltmeter
- an ammeter
- a galvanometer
- two dry cells and a cell holder
- a switch
- eight connecting wires each with a crocodile clip at one end
- a resistance wire labelled X
- a resistance wire labelled AB mounted on a millimeter scale
- six 10 ohm carbon resistors
- a jockey or crocodile clip

Proceed as follows:

- (a) Set up the circuit, with the cells in *parallel* as shown in figure 2

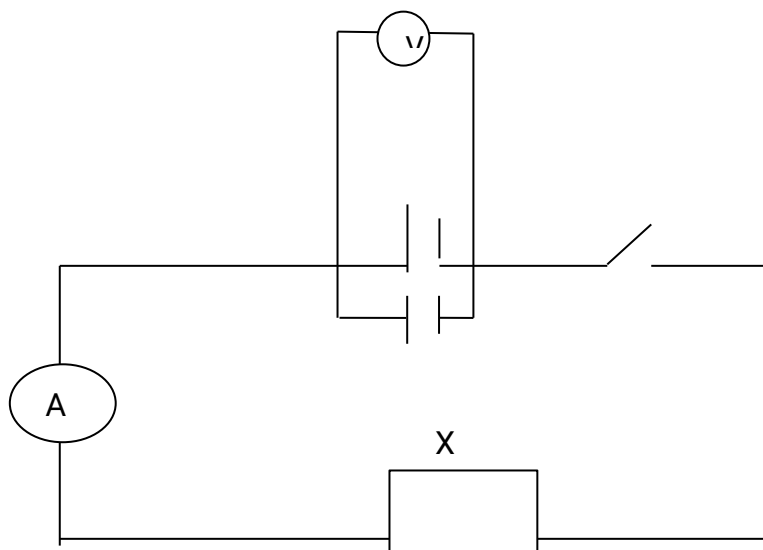

**Figure 2**

- (b) With the switch open, record the reading  $E$  of the voltmeter.

$E = \dots\dots\dots$ volts. (1 mk)

- (c) Close the switch. Record the current  $I$  flowing in the circuit and the potential difference  $V$  across the cells.

$I = \dots\dots\dots$ A (1 mk)

$V = \dots\dots\dots$ volts (1 mk)

- (d) Given that  $E = V + Ir$  and  $V = IX$

determine the internal resistance  $r$  of the combined cells and the resistance of the wire labelled X

$r = \dots\dots\dots$ ohms (1 mk)

$X = \dots\dots\dots$ ohms (1 mk)

Now set up the circuit as shown in figure3. Z is one of the 10 ohms carbon resistors.

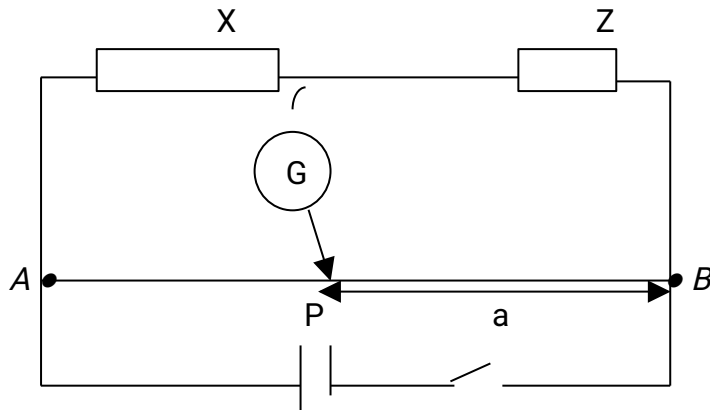

Figure 3

{f}Close the switch. Tap the jockey at various points on the wire AB and locate a point P at which the galvanometer shows zero deflection. Measure and record in table 2 the length a, where  $a = PB$

{g}Repeat the procedure in {f} using **two** resistors in parallel, **three** resistors in parallel,

**four** resistors in parallel, **five** resistors in parallel and **six** resistors in parallel.

Record

your readings in table 2. Complete the table. R is the effective resistance for the parallel combination.

Table 2

Number of 10Ω carbon resistors	One	Two	Three	Four	Five	six
$a$ (cm)						
$\frac{1}{R}$ { $\Omega^{-1}$ }						
$\frac{1}{a}$ { $cm^{-1}$ }						

(6 mks)

{h} Plot a graph of  $\frac{1}{a}$  {y-axis against  $\frac{1}{R}$

{i} Determine the slope ,m, of the graph

(2mks)

{j} Given that  $\frac{1}{a} = \frac{X}{kR} + \frac{1}{k}$ , where k =100cm

(2mks)

## PHYSICS PAPER 3 ( 232/3)

### PRACTICAL QUESTIONS

### PAPER 3

OCT/NOV. 2010

1 You are provided with the following:

- a metre rule;
- vernier callipers;
- a 300 g mass;
- two knife edges;
- some thread.

Proceed as follows:

- (a) Place the metre rule on the knife edges such that each knife edge is 45 cm from the 50 cm mark (centre of the rule). See **figure 1**. Ensure that the millimetre scale of the metre rule is facing upwards. The distance L between the knife edges is now 900 mm.
- Place the vernier callipers vertically against the metre rule at the 50 cm mark with the depth gauge lowered to touch the bench as shown in figure 1.
- Record the height  $h_0$ , of the upper edge of the metre rule at the 50 cm mark. (see **figure 1**).

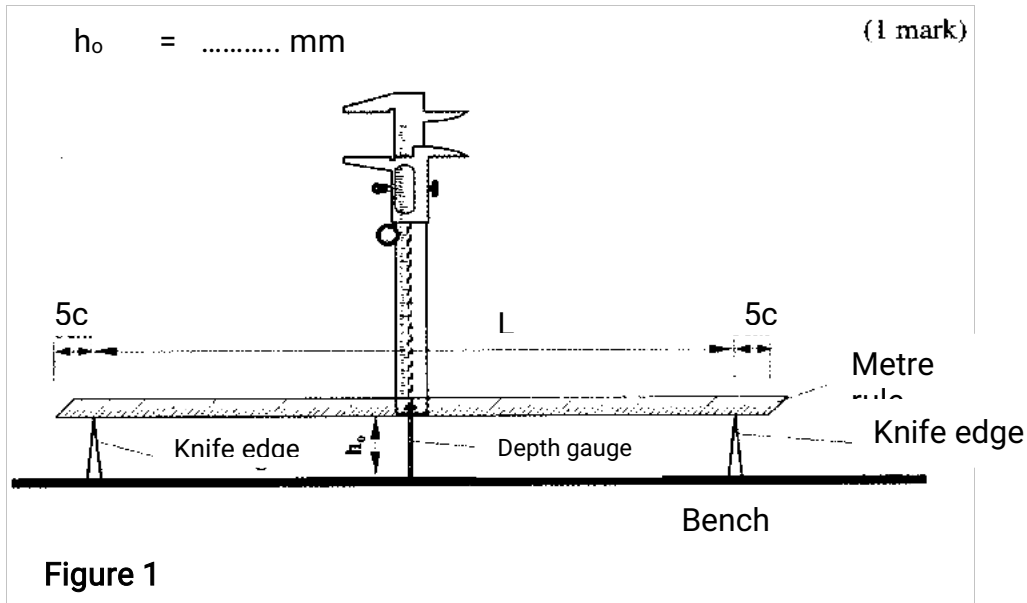

- (b) Using the thread provided, hang the 300g mass at the 50 cm mark of the metre rule. Ensure that the mass does not touch the bench. Measure and record in table 1, the height  $h$  of the edge of the metre rule at the 50 cm mark.
- (c) With the 300g mass still at the 50 cm mark, adjust the position of the knife edges so that  $L$  is now 800 mm. (The knife edges should be equidistant from the centre of the metre rule). Measure and record in table 1 the height  $h$  of the edge of the metre rule at the 50 cm mark
- d) Repeat the procedure in (c) for other values of  $L$  shown in table 1. Complete the table.

Length $L$ (mm)	900	800	700	600	500
Height $h$ (mm)					
Depression $d$ ( $h_0-h$ ) mm					
Log $L$					
Log $d$					

Table 1 (7 mks)

e) Plot a graph of  $\log L$  (y – axis ) against  $\log d$ . (5 mks)

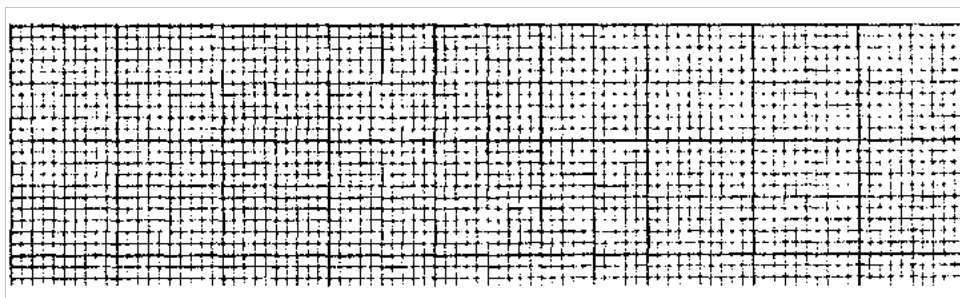

(f) (i) Determine the slope  $s$  of the graph, (3 mks)

(ii) Evaluate  $y = \frac{1}{S}$

$y = \dots\dots\dots$  (1 mk)

(iii) Determine  $G$ , the value of  $\log L$ , when  $\log d = 0$ .

$G = \dots\dots\dots$  (2 mks)

iv) Given that  $G = \frac{\text{Log } K}{y}$  determine the value of  $k$

$k \dots\dots\dots$  (1mks)

2. You are provided with the following:

- a 100 ml beaker;
- a 600 ml beaker;
- 2 thermometers range  $-10^{\circ}\text{C}$  to  $110^{\circ}\text{C}$ ;
- a measuring cylinder; (to be shared)
- some plasticine;
- vernier callipers; (to be shared)
- a meter-rule or half metre rule;
- some boiling water;
- some cold water; (at room temperature).
- stopwatch; .
- a stirrer.

Proceed as follows:

(a) Using the vernier callipers, measure the internal diameter  $d_1$ , and the external diameter  $d_2$  of the 100 ml beaker.

$D_1 = \dots\dots\dots\text{cm}$

$D_2 = \dots\dots\dots\text{cm}$  (1 mk)



Determine the thickness  $X$  of the glass wall of the beaker, given that  $X = \frac{d_2 - d_1}{2}$

$X = \dots\dots\dots$ cm

- b) Using the measuring cylinder provided, pour 75 ml of cold water into the small beaker. Measure the height  $h$ , of the water in the small beaker.

$h = \dots\dots\dots$ cm

Determine the area  $A$  of the glass walls in contact with water, given that

$$A = \pi d_1 h.$$

- c) Use the plasticine provided to make a circular disc of about the same area as the bottom surface of the smaller beaker and about 1 cm thick. Place this disc at the bottom of the large beaker and place the small beaker on it. Now pour boiling water into the large beaker until the levels of the water in the two beakers are same.

See figure 2.

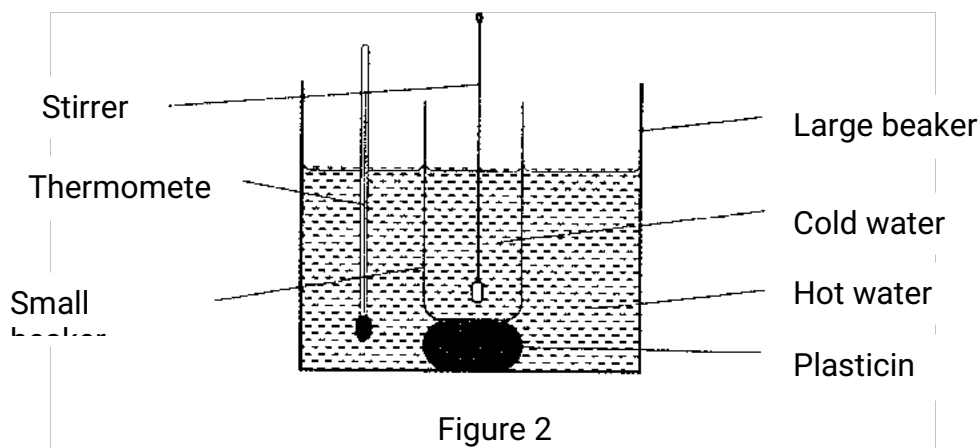

Place a thermometer in the hot water and stir gently until the temperature drops to  $75^\circ\text{C}$ . Now start the stopwatch and measure the temperature  $T_1$  of the hot water at intervals of 20 seconds. Record the values in Table 2 (Stir the water in the two beakers before taking the readings).

Pour out the contents of the two beakers.

Measure another 75 ml of cold water and put it into the small beaker. Place the small beaker inside the large beaker on the plasticine disc as before. Again pour boiling water into the large beaker until the levels of the water in the two beakers are the same. Place one thermometer in the cold water and the other in the hot water. Stir gently until the temperature of the hot water drops to 75°C. Start the stop watch and immediately read and record in Table 2 the temperature  $T_2$  of the cold water. (You may now remove the thermometer in the hot water).

Read other values of  $T_2$  at intervals of 20s and record in table 2.

Time t (seconds)	0	20	40	60	80	100	120	140	160	180
Temperature $T_1$ , °C										
Temperature $T_2$ , °C										

(6 mks)

(f) Plot a graph of temperature  $T$  (y-axis) against time

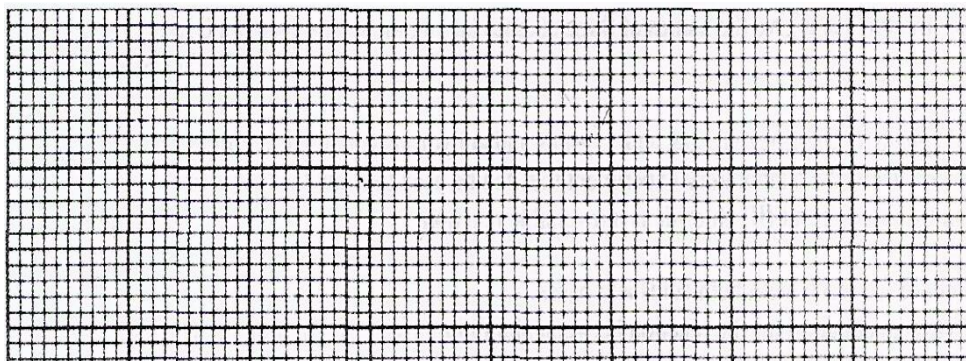

(i) Determine the slope  $S$  of the graph at time  $t = 60$  seconds.  
(3 mks)

(ii) Determine the constant  $k$ , given that  $k = -\frac{315 SX}{A(T_1 - T_2)}$

where  $T_1$  and  $T_2$  are the temperatures of the hot and the cold water

at  $t = 60\text{s}$ , and  $X$  and  $A$  are in  $\text{m}$  and  $\text{m}^2$  respectively.

(2 mks)

## PHYSICS PAPER 3 ( 232/3)

PRACTICAL QUESTIONS

PAPER 3

OCT/NOV. 2011

### Question 1

#### Part A

You are provided with the following:

- a voltmeter
- a resistance wire labelled P mounted on a metre rule.
- a resistance wire labelled Q mounted on a piece of carton.
- 2 dry cells and a cell holder.
- 6 connecting wires, each with a crocodile clip at one end.
- a switch.

Proceed as follows:

- (a) Place the dry cells in series in the cell holder. Measure and record the total emf  $E$  of the cells.
- (b) Connect the circuit as shown in figure 1 .

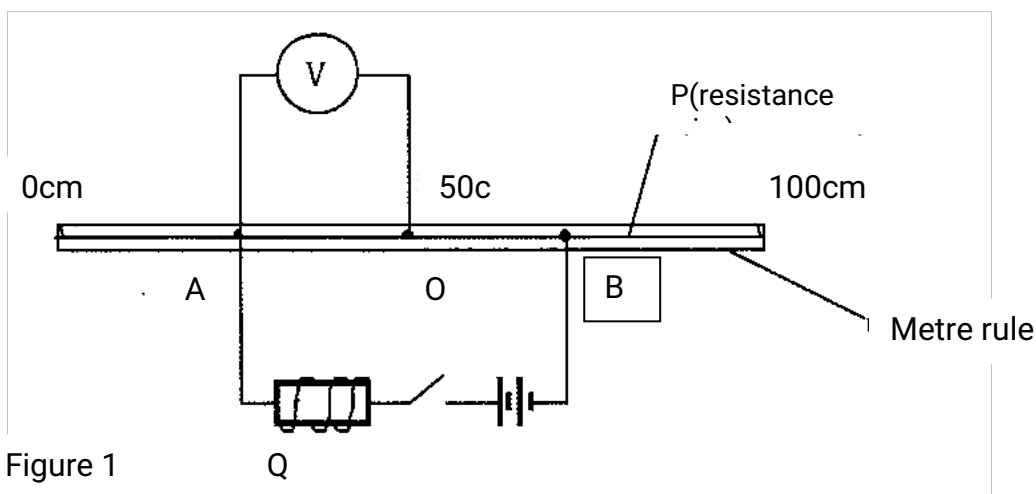

O is a point on P at the 50cm mark of the metre rule . A and B are points on P such that  $AO = OB = X$

- (c) Adjust the positions of the crocodile clips A and B on P such that  $AO = OB = X = 25\text{cm}$ . Close the switch. Read and record the potential difference ( $V$ ) across AO in table 1 .
- (d) Repeat part (c) for other values of X shown in table 1 and complete the table.

Table 1

AO = OB = Xcm	25	30	35	40	45	50
Potential differential. V (V) (2d.p)						
$1/x \text{ cm}^{-1}$ (3d.p)						
$1/v \text{ (v}^{-1}\text{)}$ (2d.p)						

- e) On the grid provided, plot a graph of  $1/v$  (y – axis ) against  $1/x$  (5 mks)

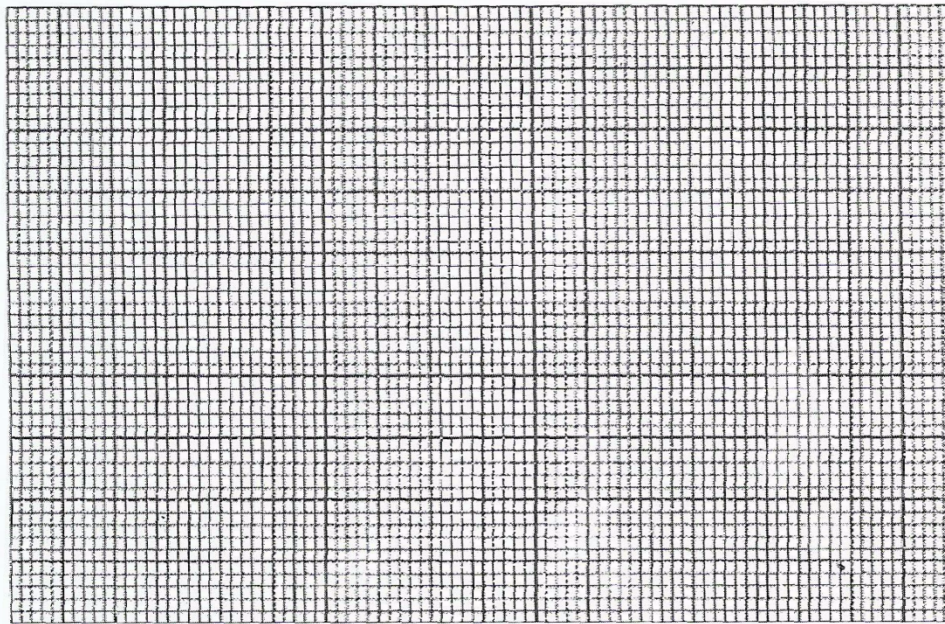

f) Determine the slope  $S$  of the graph

(3 mks)

g) Use the slope to determine the constant  $h$ , given that  $h = \underline{8}$

(2 mks)

F S

### Part B

You are provided with the following:

- a soft drawing board.
- a semicircular glass block.
- three drawing pins.
- a white paper.
- a liquid labelled L.
- a dropper.

Proceed as follows:

- (h) Place the white paper on the drawing board. Place the semicircular glass block on the paper and trace its outline using a pencil.
- (i) At the centre of the straight edge of the outline mark a point O. Also mark a point X approximately at the centre of the curved edge of the outline as shown in the figure 2

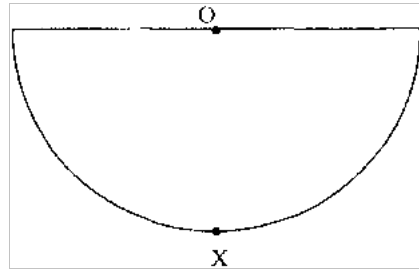

- i) Place the semicircular glass block on the outline. Push a drawing pin vertically through O into the drawing board. Ensure the pin is in contact with the glass block. Using a dropper, place two or three drops of liquid L on the pin, so that the liquid flows down the pin forming a thin film between the pin and the vertical face of the glass block.

View the image of the pin from point X through the glass block and move the eye round the curved surface to the right side of X until the image of the pin just disappears from view, (see figure 3)

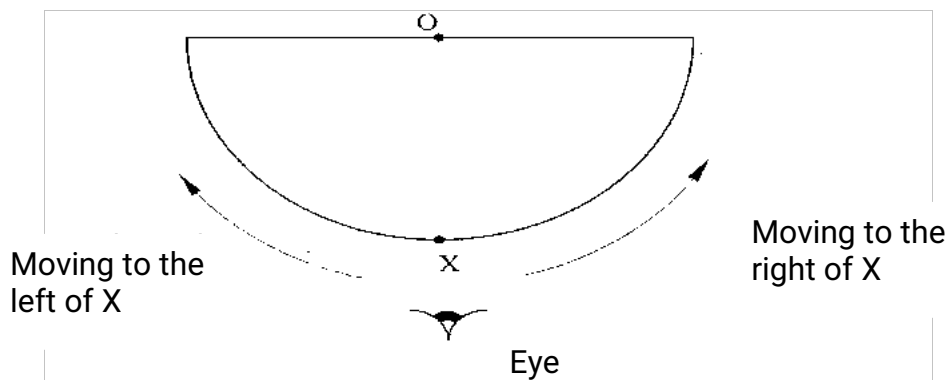

Using a second pin locate and mk a point N on the curved outline at the point where the image just disappears.

- l) Repeat part f() with the eye moving to the left side of X. Locate and mk the point

M on the curved outline where the image just disappears from view

- (m) Draw the lines OM and ON on the outline.
- (n) (i) Measure and record angle MON. (2 mks)  
 $\angle MON = \dots\dots\dots$
- (ii) If  $\angle MON = 2A$ , determine  $q$  given that  $\text{Sine } A = \frac{2}{3}q$  (2 mks)

*(The drawing bearing the candidates index number must be attached to the script).*

**Question 2**

**Part A**

You are provided with the following:

- a 100ml glass beaker.
- a weighing balance (to be shared).
- a liquid labelled L.
- a measuring cylinder.

Proceed as follows:

- (a) Measure and record the mass  $M$  of the empty beaker. (1 mk)  
 $M_1 \dots\dots\dots g$
- (b) Measure and pour 2ml of liquid L into the beaker. Measure and record the mass  $M_2$  of the beaker 4- liquid L. (1 mk)  
 $M_2 \dots\dots\dots g$
- (c) Determine the density  $d$  of the liquid L. (2 mks)  
 $d = \dots\dots\dots$

**Part B**

You are provided with the following:

- a retort stand, boss and clamp.
- 2 boiling tubes.
- a thermometer.
- some distilled water in a beaker labelled W.
- some liquid in a beaker labelled L.
- a large beaker containing some water.
- a measuring cylinder.
- a stopwatch.
- a tripod stand and wire gauze.

- a cardboard with a hole in the middle.
- a burner.

**Proceed as follows:**

- (d) Clamp one boiling tube on the retort stand. Measure and pour 45ml of the distilled water (W) into the boiling tube. Set up the apparatus as shown in figure 4.

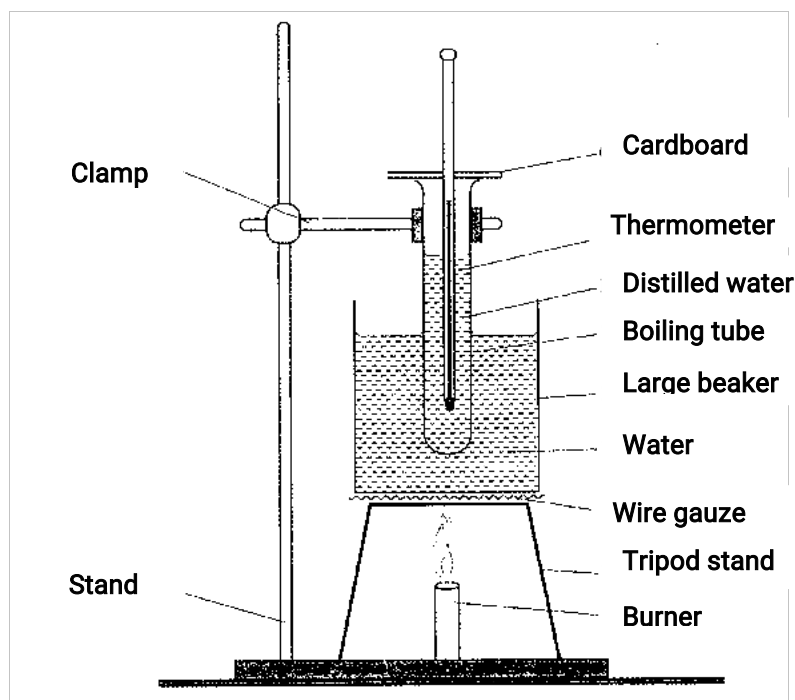

**Figure 4**

- e) Heat the water in the large beaker until the temperature of the distilled water reaches 85°C. Remove the boiling tube from the hot water by lifting up the retort stand and placing it a way from the burner.
- f) Stir the water in the boiling tube using the thermometer. Record in the table 2 the temperature of the distilled water at intervals of 30 seconds starting at 80°C until it drops to 60°C. (*Stir the distilled water before taking any reading*).

**Table 2**



Time in minutes	0	0.5	1.0	1.5	2.0	2.5	3.0	3.5	4.0	4.5
Temperature of W(°C) (to the nearest 0.5)										
Temperature of L (°C) (to the nearest 0.5)										

Time in minutes	5.0	5.5	6.0	6.5	7.0	7.5	8.0	8.5	9.0	9.5	10.0
Temperature of W(°C) (to the nearest 0.5)											
Temperature of L (°C) (to the nearest 0.5)											

(g) Using the second boiling tube, repeat the procedure in (d), (e) and (f) using 45ml of liquid L instead of distilled water. Record your results in the same table. (4 mks)

(h) Using the same axes on the grid provided, plot a graph of temperature (y - axis) against time for:

- (i) Distilled water W. (5 mks)
- (ii) Liquid L. (3 mks)

(Label the graphs of L and W).

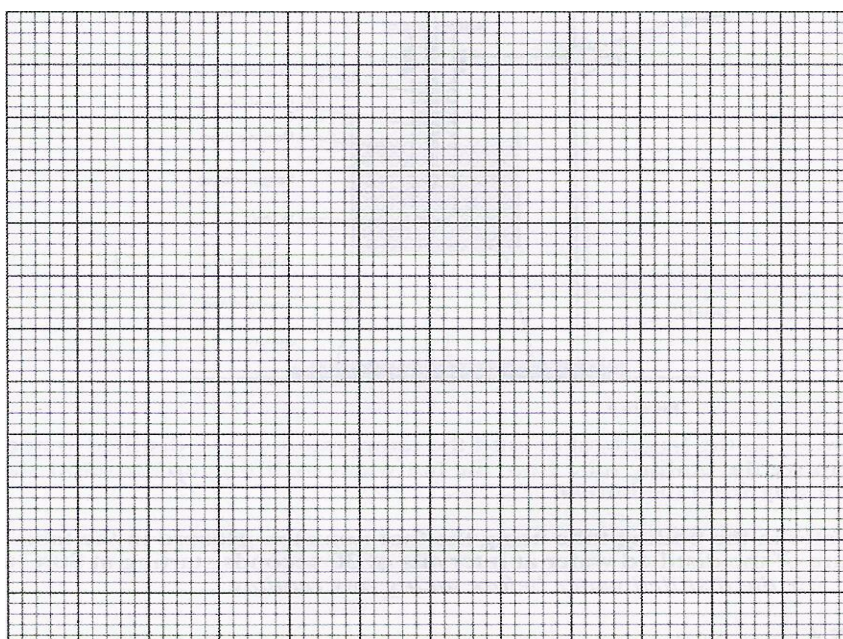

- (i) From the graphs determine:
- (i) the time retaken for the distilled water to cool from 75°C to 65°C.  
 $t_w = \dots\dots\dots$  minutes
- (ii) The time  $t_L$  taken for liquid L to cool from 75°C to 65°C,  
 $t_L = \dots\dots\dots$  minutes

- (j) Determine the constant  $r$  given that  $r = \frac{4.2I_L}{dt_w}$  where  $d$  is the density of the liquid L in part (A). (2 mks)

## PHYSICS PAPER 3 ( 232/3)

### PRACTICAL MARKING SCHEME

### PAPER 3

OCT/NOV. 2012

#### Question 1

You are provided with the following:

- two biconvex lenses labelled A and B.
- alight source.
- Screen I with a hole and cross wires at its centre.
- Screen II.
- a metre rule.
- a plane mirror.
- a piece of cellotape.
- two lens holders.
- a stand, boss and clamp.

#### Proceed as follows:

- (a) Mount lens A on the lens holder. Fix the plane mirror at the back of the lens using the cellotape provided. Use the stand to hold the light source in line with the crosswires on screen I and lens A with the plane mirror as shown in **figure**

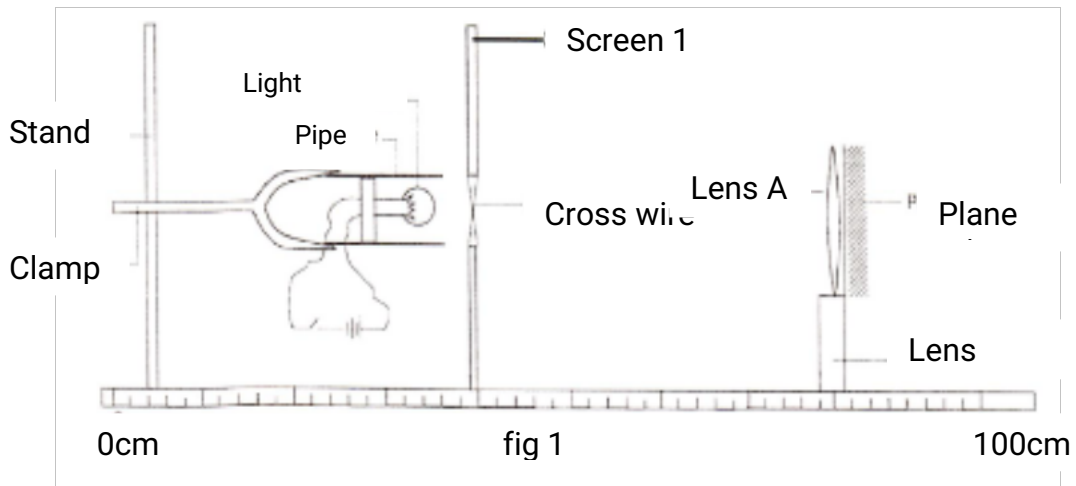

(b) Switch on the lamp. Adjust the position of the lens with the mirror until a sharp image

of the crosswires is formed on screen I beside the crosswires. Measure the distance

$l_1$ , between the screen and lens A.

$l_1, \dots \dots \dots \text{cm}$

(c) Replace lens A with lens B. Fix the plane mirror at the back of lens B. Repeat the

procedure in (b) above. Measure the distance / between the screen and lens B.

$L_2, \dots \dots \dots \text{cm}$

(d) Remove the mirror from the lens holder.

Arrange the light source, Screen I (with crosswires), lens A, lens B and screen II in line as shown in **figure 2**

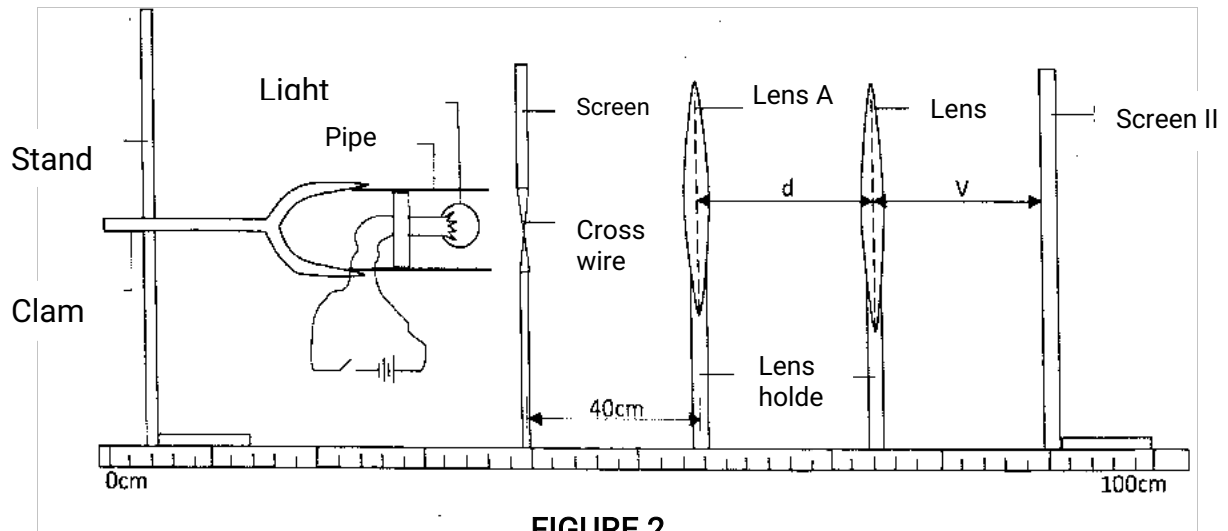

FIGURE 2

- (e) Set the distance between Screen I and lens A to be 40 cm. **Ensure that this distance is maintained throughout the rest of the experiment.** Set the distance  $d$  between lens A and lens B to be 65 cm. Adjust the position of screen II to obtain a sharp image of the cross wires on it. Measure the distance  $v$  between lens B and screen II. Repeat the experiment for other values of  $d$  shown in table 1 and complete the table.

Table 1

$d(\text{cm})$	65	67	69	71	73	77	80
$v(\text{cm})$							

- (f) On the axes provided below, plot the graph of  $v$ (y-axis) against  $d$ .

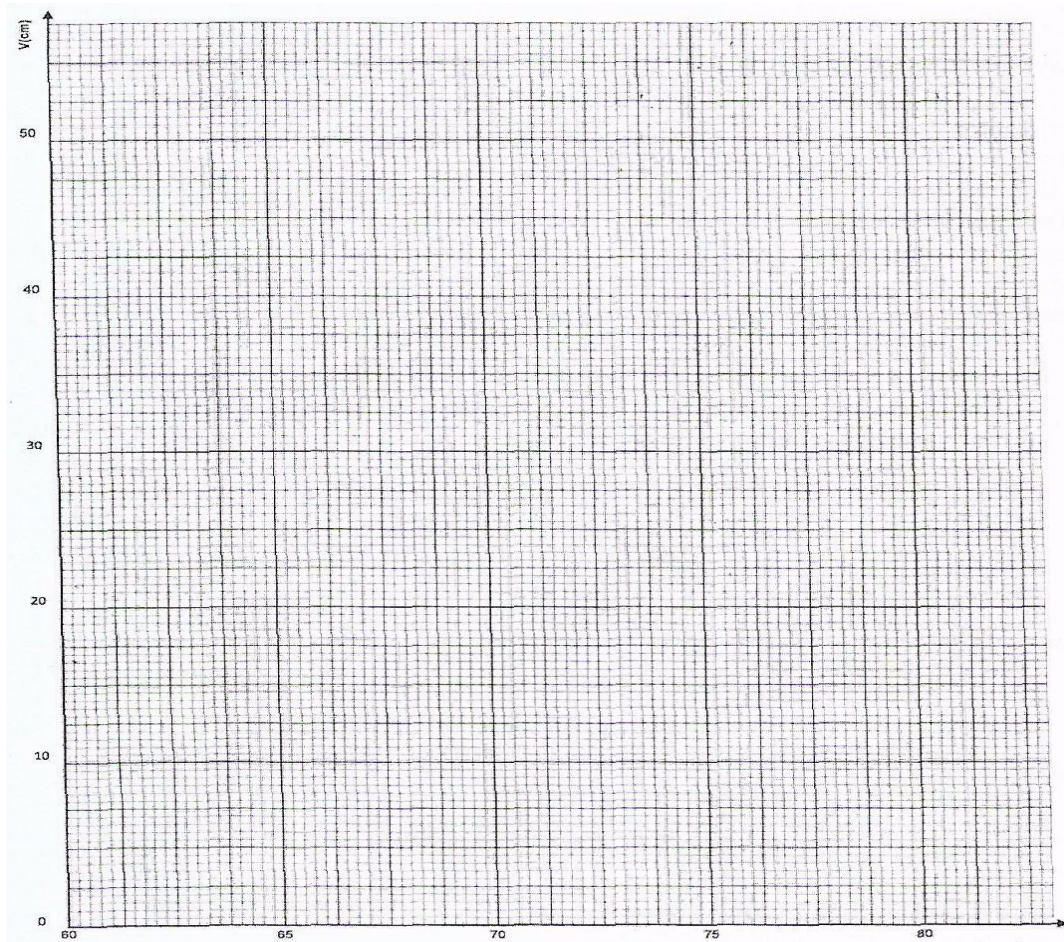

- (g) (i) From the graph, at  $d = 70$  cm, determine:
- I. the value of  $v$ . (1 mk)
  - II. the slope  $S$  of the graph. (3 mks)

ii) Given that  $K = \frac{-225}{(d-55)^2}$   
 Determine the value of  $K$  (2 Mks)

iii) Determine the value of  $m$  given that  $m = \frac{S}{K}$  (2 mks)

You are provided with the following:

- o a voltmeter
- o a diode with ends labelled B and C
- o a 1 k $\Omega$  resistor
- o a 50  $\Omega$  potentiometer
- o 3 dry cells and a cell holder
- o a switch
- o 8 connecting wires (at least 4 with crocodile clips)

Proceed as follows:

(a) Set up the circuit as shown in figure 3.

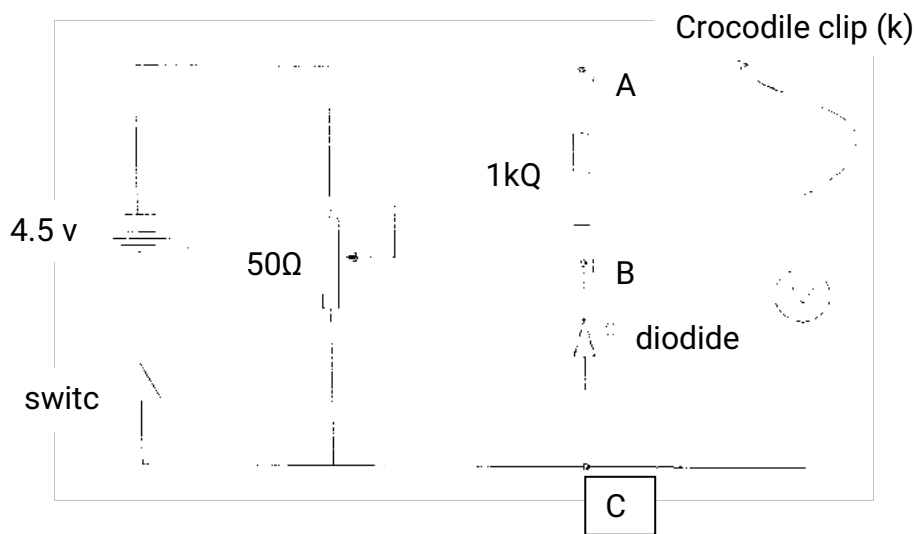

B i) Connect the crocodile clip K to point A. Adjust the potentiometer by turning the knob until the voltmeter reading is maximum

ii) Without adjusting the potentiometer, disconnect the crocodile clip K from point A

and connect it to point B . Record the voltmeter reading.

Voltmeter reading = ..... volts. (1 mk)

(iii) Explain why the voltmeter reading in b(i) is different from that in b(ii). (2 mks)

c) Disconnect the crocodile clip K from point B and connect it to point A. Adjust the

potentiometer so that the voltmeter reading  $V_A$  is 1.0 V. Disconnect the crocodile clip

K from A and connect it to point B. Record the voltmeter reading  $V_B$ .

$V_B = \dots\dots\dots$ Volts (1 mk)

By adjusting the potentiometer to obtain other values of  $V_A$  (when K is at A) shown in **table 2**, repeat the procedure in (c) to obtain the corresponding values of  $V_B$  (when K is at B) and complete the table (7mks)

<b>Table 2</b>		
$V_A$ (V)	$V_B$ (V)	$I = \left( \frac{V_A - V_B}{1000} \right) (A)$
1.5		
2.0		
2.5		
3.0		
3.5		
4.0		

e) On the grid provided, plot a graph of I (y – axis ) against  $V_B$ . (5mks)

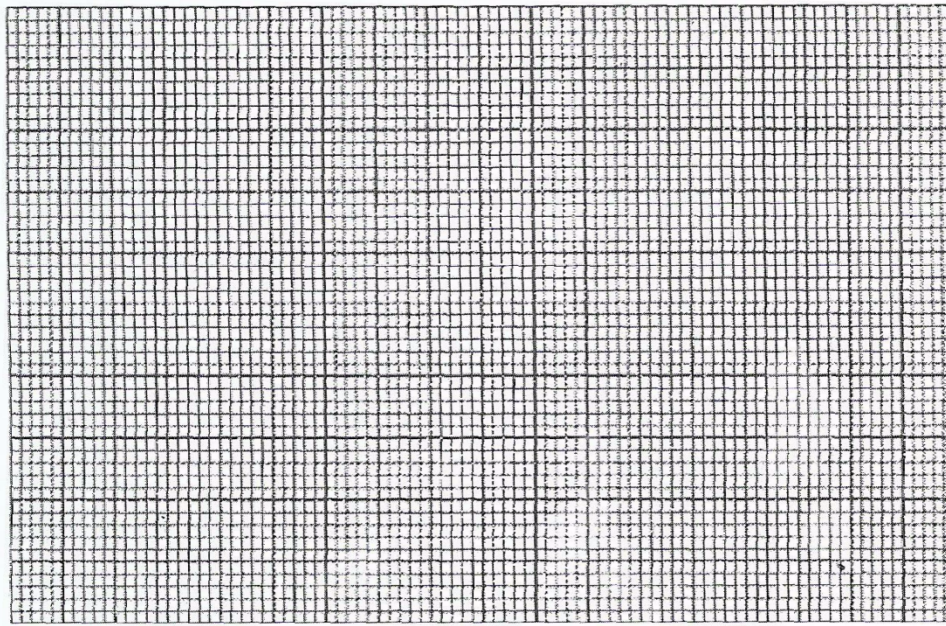

f) Use the graph to determine the resistance of the diode when the current is 0.45 mA.

## PHYSICS PAPER 3 ( 232/3)

### PRACTICAL QUESTIONS

### PAPER 3

OCT/NOV. 2013

Question 1 . *This question consists of two parts A and B; attempt both parts.*

#### PART A

You are provided with the following:

- a pendulum bob
- a stop-watch
- two metre rules
- two retort stands, two bosses and two clamps.
- some thread.



Proceed as follows:

- (a) Clamp one metre rule horizontally on the two stands so that the graduations are in a vertical plane. Suspend the pendulum bob from the metre rule with two pieces of thread so that the length of each thread from the point of support on the metre rule to the pendulum bob is 50 cm. See figure 1. *The length of each thread will remain 50 cm throughout the experiment. The height of the metre rule above the bench should be at least 65 cm.*

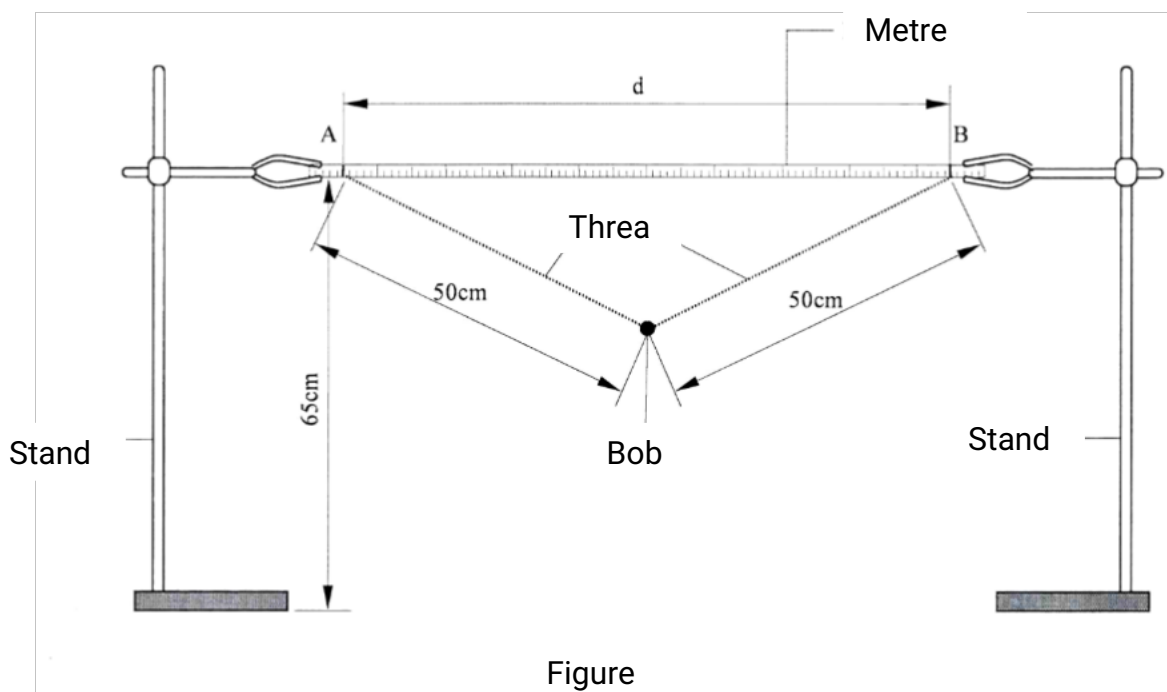

- (b) Set the distance  $d$  between **A** and **B** to be 70 cm. Displace the pendulum bob slightly in a plane perpendicular to the length of the metre rule and release it so that it oscillates in that plane. Measure and record in **table 1** the time  $t$  for 20 oscillations.

- (c) Repeat the procedure in (b) for other values of  $d$  shown in **table 1**. Complete the table.

Distance $d$ (cm)	70	60	50	40
-------------------	----	----	----	----

Time t for 20 oscillations (s)				
Period T =				
$T^4$ (s <sup>4</sup> )				
$d^2$ (cm <sup>2</sup> )				

**Table 1**

(d) (i) Plot a graph of T (y - axis) against d

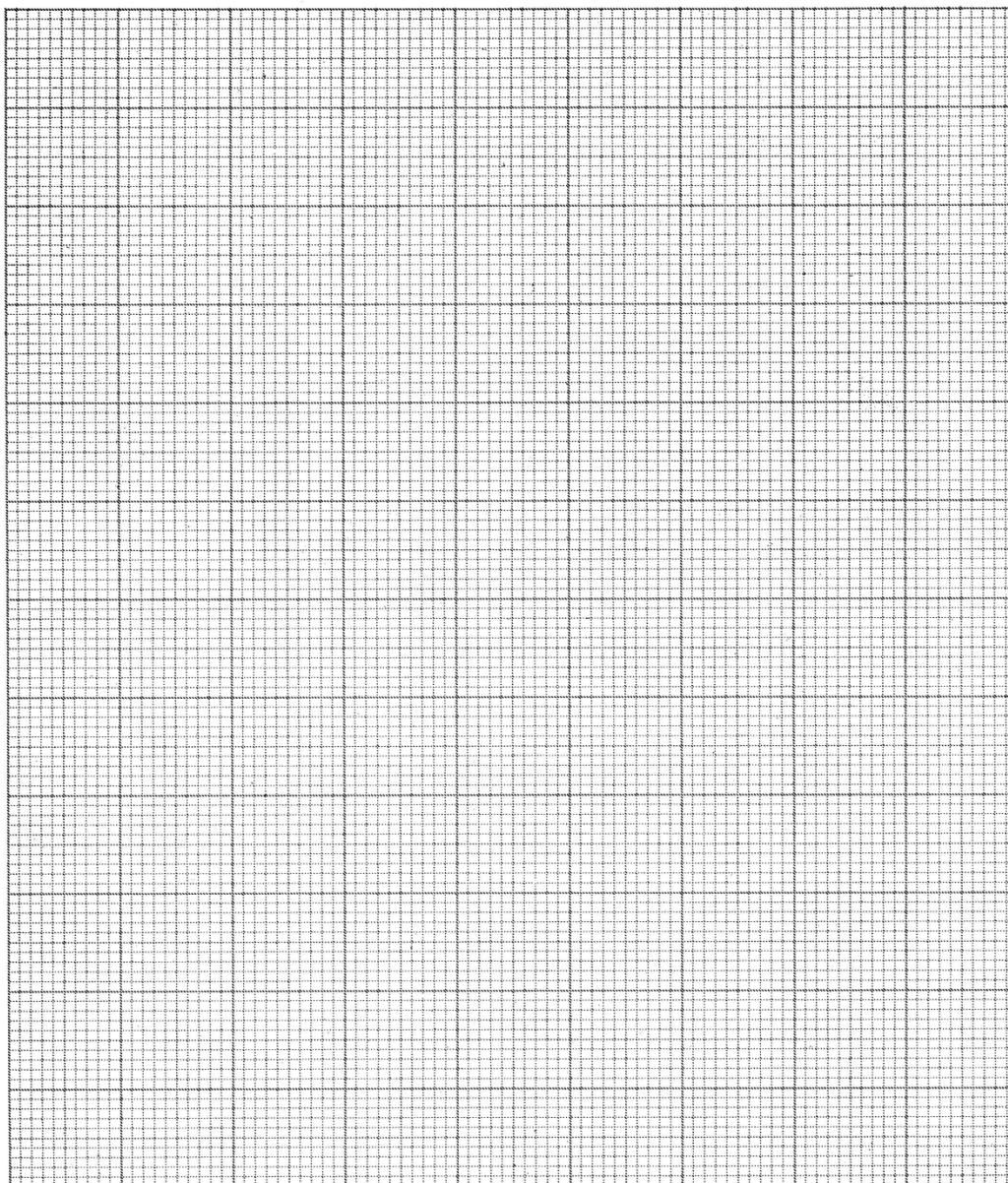

(ii) Determine the slopes S of the graph.

(2 mks)

(iii) Given that  $S = \frac{-4\pi^4}{K^2}$  determine the value of K.

(2 mks)

**PART B**

You are provided with the following:

- two stands, two clamps and two bosses.
- one meter rule
- one Bar magnet
- a piece of thread
- weighing balance (to be shared)
- stop watch

Proceed as follows.

(e) Using the meter rule measure the length  $L$  and breadth  $b$  for the magnet.

( $b$  is the second largest dimension of the magnet).

$L = \dots\dots\dots$  m

$b = \dots\dots\dots$  m (1 mk)

(f) Use the balance to measure the mass  $M$  of the magnet.

$M = \dots\dots\dots$  kg. (1 mk)

(g) Determine  $P$  given that (2 mks)

(h) Clamp the meter rule between the two resort stands. Using a piece of thread suspend the bar magnet from the centre of the metre rule so that its length and breadth are both

in a horizontal plane as shown in **figure 2**.

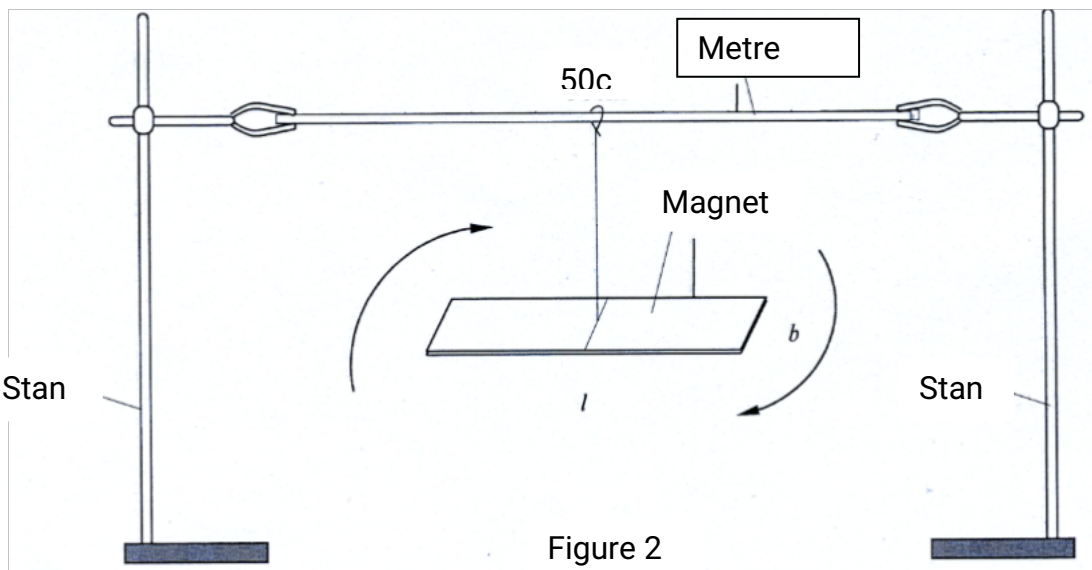

Keep away all unnecessary magnetic materials including voltmeter from this experimental set up.

(i) (I) Displace one end of the magnet through a small angle and let it oscillate about a vertical axis through its centre as shown by the arrows. Measure the time  $t$  for 10 oscillations. (1 mk)

(a)  $t = \dots\dots\dots$  s

(II) Determine the period  $T$  of the oscillations.

(1 mk)

(III) Determine the constant  $G$  given that

### Question 2

*This question consists of **two** parts **A** and **B**, attempt both parts.*

#### PART A

You are provided with the following

- a voltmeter
- a capacitor
- a switch
- a stop watch
- five connecting wires
- two cells and a cell holder

Proceed as follows:

(a) Connect the circuit as shown in **figure 3**.

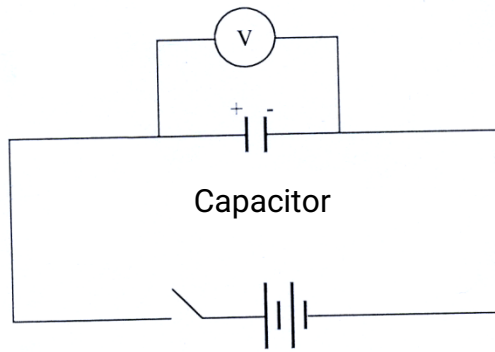

Figure 3

Make sure that the terminals of the capacitor and those of the battery are correctly connected, (*positive to positive and negative to negative*).

(b) Close the switch, read and record the maximum voltage  $V_0$ , across the capacitor.  
 =.....volts (1 mk)

(c) While the voltmeter shows the maximum voltage  $V_0$ , open the switch and start the stop watch simultaneously. Stop the stopwatch when the voltage has dropped from  $V_0$  to 2.5 V. Read and record in **table 2** the time taken.

(d) Reset the stopwatch and close the switch. Repeat the procedure in (c) to measure and record the time taken for the voltage to drop from  $V_0$ , to each of the other values shown in **table 2**.

Voltage (v)	2.5	2.25	2.0	1.75	1.50	1.25
Time, t (s)						

(3 mks)

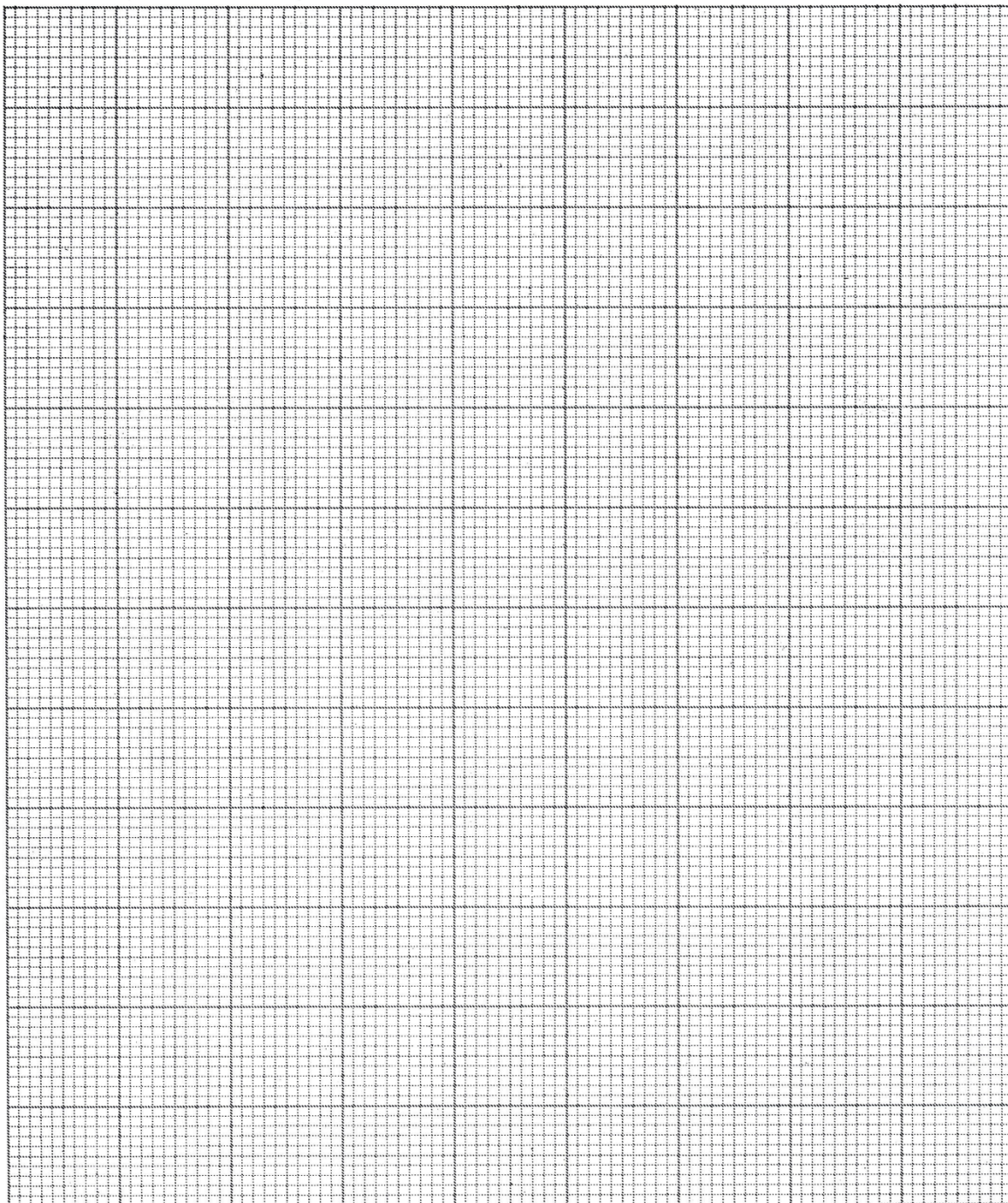

(e) (i) On the grid provided, plot a graph of Voltage  $V$  (y-axis) against time  $t$ ,  
(4 mks)

(ii) Use the graph to determine the time

$$V = \frac{V_0}{2} = \dots\dots\dots \text{ seconds} \quad (1 \text{ mk})$$

(f) Determine the resistance  $R$  of the voltmeter given that

$t = \dots\dots\dots 0.693CR$  where  $C$  is the capacitance of the capacitor.

## PART B

You are provided with the following:

- a triangular glass prism
- a metre rule
- a 50 g mass
- some hot water
- some cold water
- some thread
- a thermometer
- one stand, one boss and one clamp
- a beaker

Proceed as follows:

(g) Using a piece of thread suspend the metre rule from the clamp on the stand and adjust

the position of the thread until the metre rule balances horizontally. Note this position, O of the thread. (***This position of the thread must be maintained throughout the experiment.***)

(h) Using another piece of thread suspend the glass prism from the meter rule at a point 35 cm from O. Suspend the 50 g mass on the opposite side of O using another piece of thread. Adjust the position of the thread attached to the 50 g mass until the metre rule balances once more. **See figure 4.**

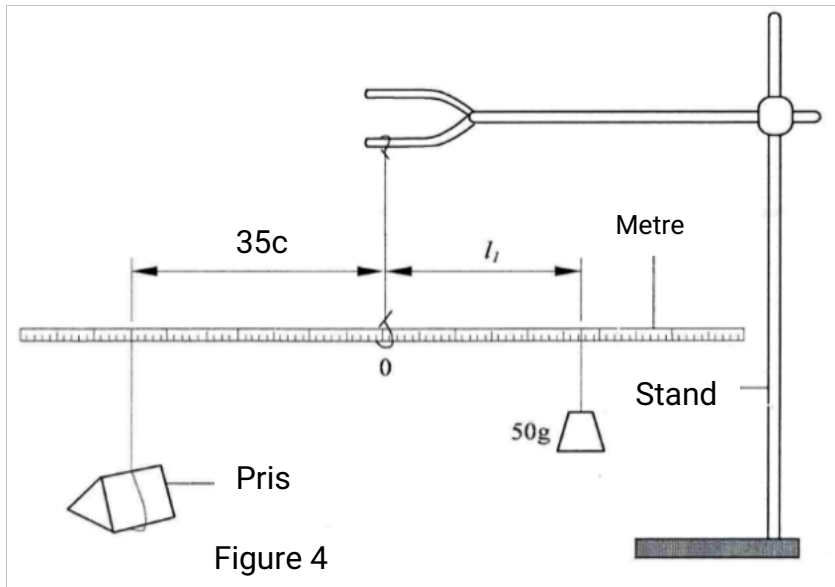

Figure 4

(i) Determine the distance  $l_1$  between O and the point of support of the 50 g mass.  
 $l = \dots\dots\dots$  cm (1 mk)

(ii) Use the principle of moments to determine the weight  $W_1$  of the prism in air.  
 (Take  $g = 10 \text{ N kg}^{-1}$ ) (1 mk)

(i) Put cold water into the beaker (approximately three quarter ( $\frac{3}{4}$ ) full). With the glass prism still at 35 cm from O, determine the distance  $l$  of the 50 g mass at which the rule balances when the prism is fully submerged in the cold water. **See figure 5.**

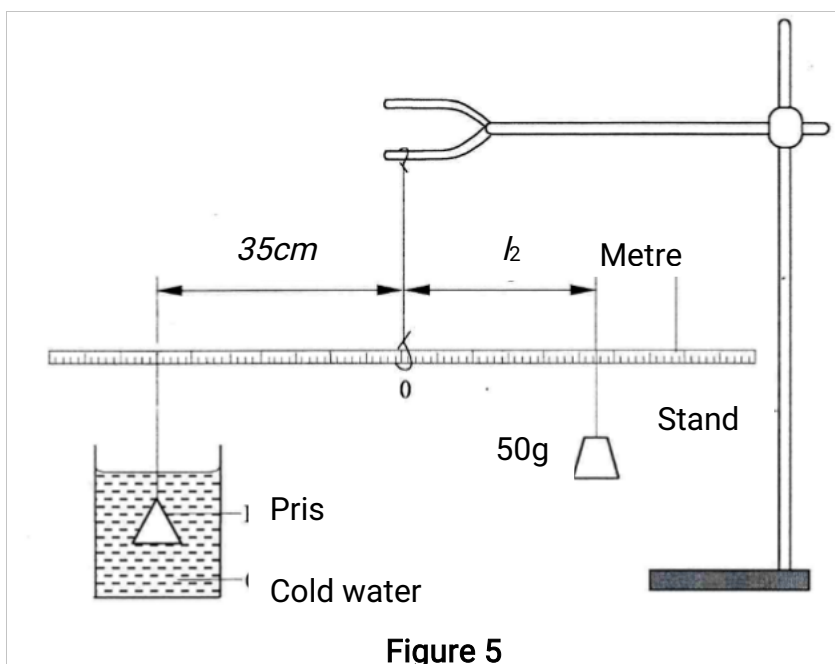

Figure 5



(I)  $l_2 = \dots\dots\dots$ cm (1 mk)

(II) Determine the weight  $W_2$  of the prism in the cold water. (1 mk)

(j) Measure and record the temperature  $T_1$  of the cold water when the system is balanced.

$T_1 = \dots\dots\dots$  cm (1 mk)

(k) Now pour out the cold water and replace it with hot water. Balance the metre Rule with the prism fully submerged in hot water. **Ensure that the prism is still supported at 35 cm from 0.**

(i) Determine the distance  $l_3$  of the point of support of the 50 g mass when the prism is submerged in hot water

$l_3 = \dots\dots\dots$  cm. (1 mk)

(ii) Measure and record the temperature  $T_1$  of the hot water.

$T_2 = \dots\dots\dots$ °C (1 mk)

(iii) Determine the weight  $W_3$  of the prism in hot water. (1 mk)

(l) Determine the constant  $k$  for the water given that:

$$k = \frac{(w_1 - w_2) - (w_1 - w_3)}{(w_1 - w_3) - (T_2 - T_1)} \quad (2 \text{ mks})$$

# PHYSICS PAPER 3 ( 232/3)

## PRACTICAL QUESTIONS

### PAPER 3

OCT/NOV. 2014

#### QUESTION /

You are provided with the following:

- a voltmeter
- a milliammeter
- a micrometer screw gauge (to be shared)
- a stopwatch
- a centre zero galvanometer
- a switch
- ten connecting wires (at least five with a crocodile clip on one end)
- a resistance wire mounted on a millimetre scale labelled AB.
- a resistance wire labelled P.
- a resistance wire labelled Q.
- a capacitor labelled C.
- a metre rule or half metre rule.
- two dry cells and a cell holder.
- a carbon resistor labelled R.

Proceed as follows:

#### PART A

(a) Using the micrometer screw gauge provided, measure the diameter:

(i) D of wire P.

D = \_\_\_\_\_ (1 mk)

(ii) d of wire Q

d = \_\_\_\_\_ (1 mk)

(b) Determine  $C_1$  the value of the ratio  $\frac{D}{d}$

$C_l = \text{_____}$  (1 mk)

c) i) Set up the circuit as shown in **Figure 1**. (Ensure that each of the wires P and Q is 50cm long)

Close the switch. Using the clip at the free end of the wire from the galvanometer, tap wire AB near end A and observe the deflection in the galvanometer.

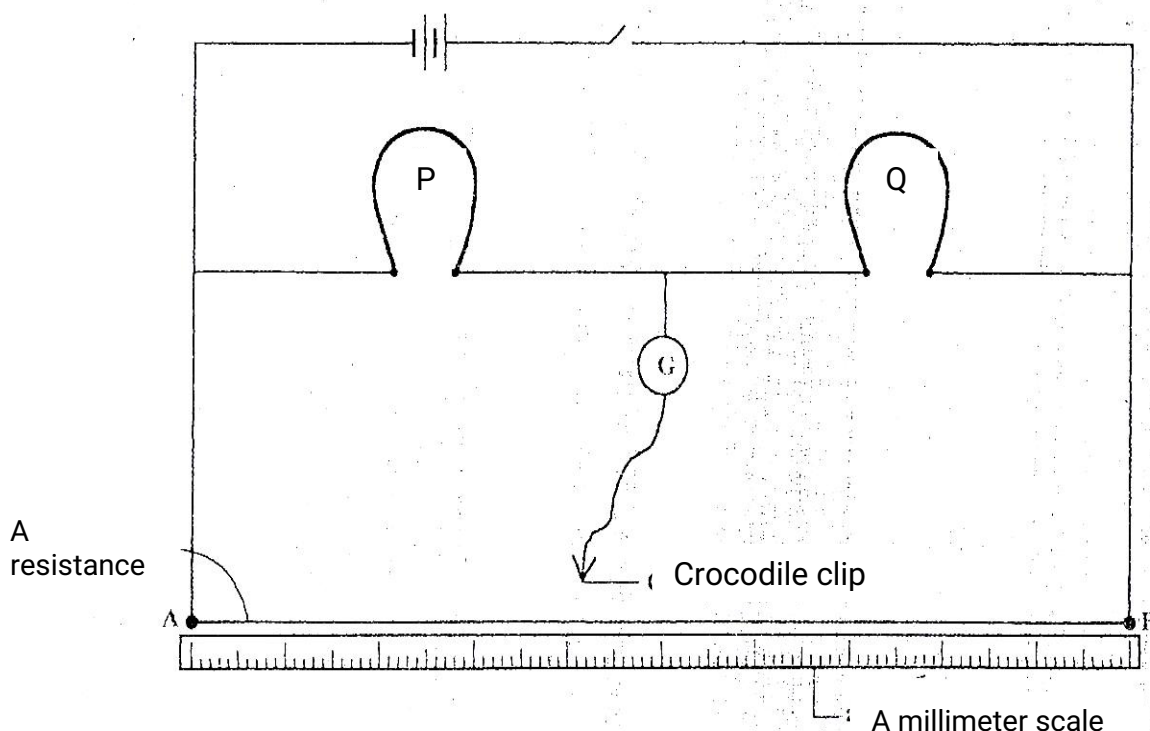

(ii) Then tap the wire near end B and again observe the deflection in the galvanometer.

(iii) Now tap the wire AB at various points between A and B to obtain a point K where there is no deflection in the galvanometer.

(I) Determine the length  $L_1$  the distance from A to K.

(1 mk)

(II) Determine the length  $L_2$ , the distance from B to K.

(1mk)

d) Given that the resistance RQ of Q is 9.0 ohms, determine the resistance  $R_p$  of P using the expression:

$$\frac{R_p}{RQ} = \frac{L_1}{L_2}$$

(2mks)

ii) Determine the value of  $C_2$  given that,

$$C_2 = \sqrt{\frac{R_Q}{R_P}}$$

(2mks)

iii) Compare the value of  $C_1$  (In part (b)) with that of  $C_2$ .

(1mk)

**PART B**

(e) set up the circuit shown in Figure 2. S and T are crocodile clips.

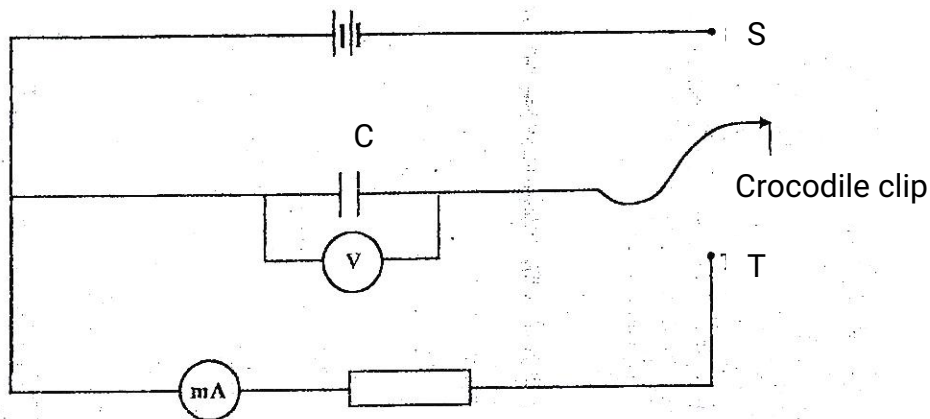

**FIGURE 2**

(i) Charge the capacitor C by connecting the crocodile clip to S. Record the reading of the voltmeter, V.

V - \_\_\_\_\_

(1 mk)

(ii) Calculate the value of the current  $I_0$ , given that  $I_0 = \frac{V}{R}$

(where  $R = 4.7 \times 10^3 \Omega$ )

(3mks)

(f) (i) Discharge the capacitor by disconnecting the crocodile clip from S and connecting it to T. Observe and record the highest reading of the milliammeter  $I_1$ . (This is the current at  $t_0 = 0$ ). (You may have to repeat the process to obtain an accurate value).

$I_1 =$  \_\_\_\_\_

(1 mk)

(ii) Recharge the capacitor by connecting the crocodile clip to S.

- (iii) Discharge the capacitor and at the same time start the stop watch to measure the time  $t_1$  taken for the current to decrease to half the value of  $I_1$  i.e. ( $\frac{1}{2} I_1$ )

$t_1 =$  \_\_\_\_\_ (1 mk)

- (g) (i) Recharge the capacitor and repeat the procedure in f(iii) to measure the time  $t_2$  taken for the current to decrease to one tenth of the value of  $I_1$  i.e. ( $\frac{1}{10} I_1$ ).

$t_2 =$  \_\_\_\_\_ (1 mk)

- (ii) Use the values of the currents  $I_1, \frac{1}{2} I_1, \frac{1}{10} I_1$  and their corresponding times to draw a graph of current  $I$  (y axis) against time on the grid provided.  
(3 mks)

## Question 2

You are provided with the following:

- a stand boss and clamp
- two wooden blocks
- a stopwatch
- a half metre rule or metre rule
- a mettalic rod
- a bare copper wire labelled M attached to a crocodile clip
- a bare copper wire labelled N attached to a crocodile clip.

Proceed as follows:

- (a) Clamp wire M between the wooden blocks so that the length / of wire between the wooden blocks and the point of its attachment on the crocodile clip is 5 cm. Clamp the mettalic rod at its mid point using the crocodile clip attached to wire. M. (See figure 3

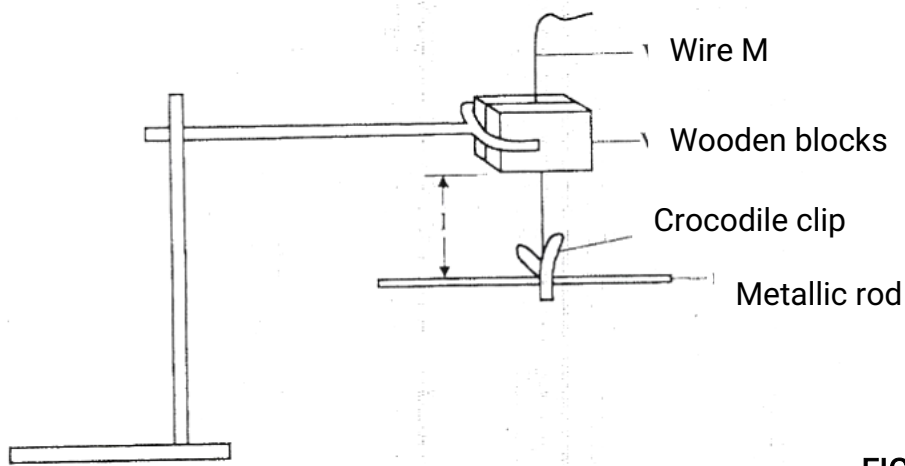

FIGURE 3

b) Displace the rod through a small angle in a horizontal plane about its mid point so that when released, it oscillates in the same plane. Record the time  $t$  for 10 oscillations and determine the period  $T$  in **Table 1**.

(c) Repeat part (b) for the other lengths of wire M shown in **Table 1**.

d) Complete table 1 (6mks)

l(cm)	5	10	15	20	25	30
t(s)						
T(s)						
$T^2(s^2)$						

e) Plot a graph of  $1$  ( y axis ) against  $T^2$ . (5mks)

(f) Determine the gradient of the graph, (3mks)

(g) Now replace wire M with wire N in the setup.

(i) For  $l = 20$  cm, displace the rod through a small angle in a horizontal plane and measure the time  $t_N$  for 10 oscillations.

$t_N =$  \_\_\_\_\_ (1 mk)

(ii) Determine the period.  $T_N =$  \_\_\_\_\_

(1 mk)

(iii) Calculate  $T_N^2$

(1 mk)

(iv) Determine the value of H given that  $H = \frac{0.2}{T_N^2}$  (1mk)

v) Calculate the value of  $\frac{H}{S}$  (2mks)

## PHYSICS PAPER 3 ( 232/3)

### PRACTICAL QUESTIONS

### PAPER 3

OCT/NOV. 2015

#### Question one

You are provided with the following:

- a micrometer screw gauge (to be shared)
- a vernier calliper (to be shared)
- glass tube
- a wire labelled M
- some sellotape one 50 g mass
- some masses (totalling 40 g)
- a meter rule
- 100 ml beaker
- a stand boss and clamp a stop watch
- a source of light a screen
- some water
- a measuring cylinder

**PART A**

Proceed as follows:

- (a) Using a micrometer screw gauge, measure and record the diameter of the wire labelled M. (1mk)

- (a) Using a micrometer screw gauge, measure and record the diameter of the wire labelled M.

d= ..... mm

d= ..... m.

- (b) Using wire M, make a spring as follows:

- (i) Use some sellotape to fix one end of the wire M (about 2.5 cm) along the glass tube;

- (ii) Hold firmly the part of the wire under the tape with one hand. Use the other hand to wind 30 turns as closely and tightly as possible.

(see figure 1)

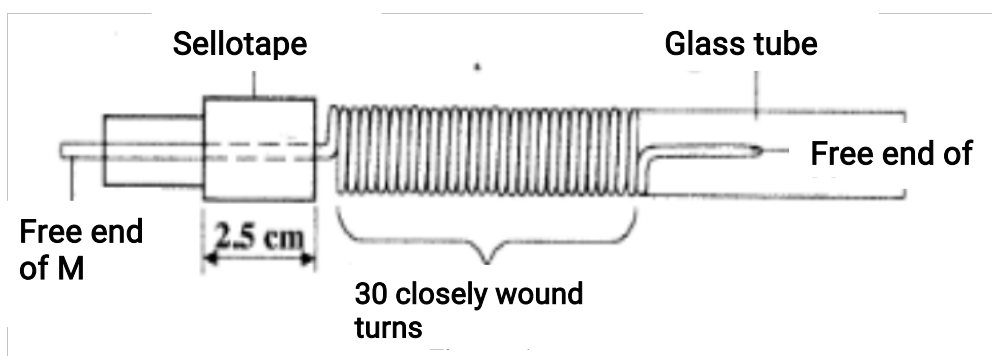

- (c) Remove the sellotape and release the spring from the tube.

*(The spring will slightly unwind and some turns will disappear)*

Bend the free ends as shown in figure 2.

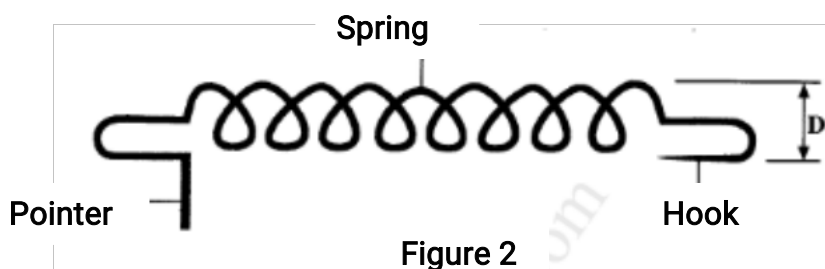

Figure 2

- (d) Using a vernier callipers, measure and record the external diameter D of the spring

(1mk)



D= ..... cm

D= ..... m.

(e) Suspend the spring and a 50 g mass from a retort stand as shown in figure 3.

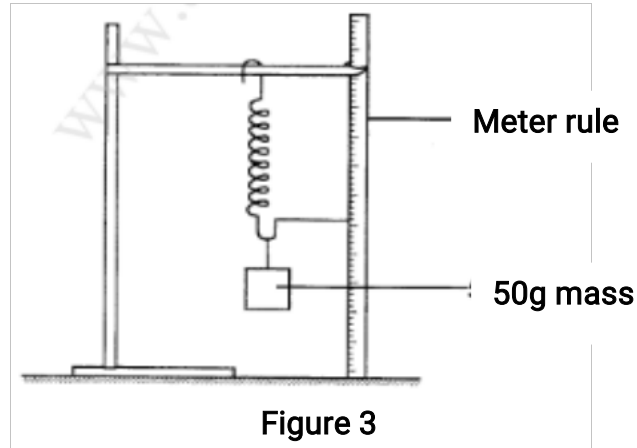

Count and record the number of turns  $N$  of the suspended spring.

$N =$

(1mk)

(f) Add 40 g to the 50 g mass and record the extension  $X$  of the spring due to the 40 g.

(1mk)

$X =$  ..... cm

$X =$  ..... m

(g) Determine  $c$  given that

(1mks)

$$c = \frac{0.4}{X}$$

(h) Determine  $n$  given that

(2mks)

$$c = \frac{nd^4}{8ND^3}$$

(i) With the spring still loaded with the 90 g, pull the lower mass slightly downwards and let go so that the mass oscillates vertically. Record the time  $t$  for 20 oscillations. Hence determine the period  $T$ .

$t =$  ..... (s)

$T = \dots\dots\dots$  (s)

Determine Z given that

$$T = 2\pi\sqrt{\frac{m}{Z}}$$

where m is the mass in kg on the spring.

(2mks)

**PART B**

Proceed as follows:

- (k) Place the 100 ml beaker on a meter rule and pour 80 cm of water into it. Arrange a lamp (source of light) and a screen on either side of the beaker. (see figure 4)

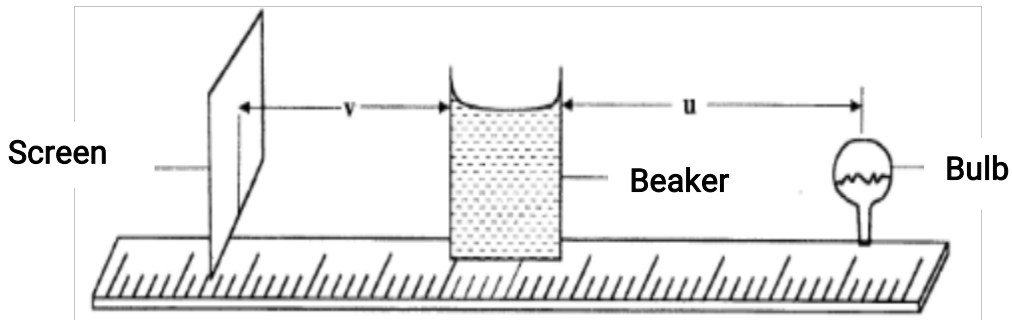

- (l) Adjust the position of the lamp on the metre rule so that its centre is a distance  $u = 12$  cm from the beaker. Switch on the light. Adjust the position of the screen until a well focused vertical line (the image of filament) is formed on the screen. Measure and record in table 1 the image distance V between the screen and the beaker.
- (m) Repeat part (l) for other values of u shown in table 1 and complete the table.

**TABLE 1**

Distance u(cm)			
Distance V(cm)			
$Y = \frac{UV}{U+V}$			

- (n) Determine m, the mean value of y using the values in table 1. (1 mk) (4 mks)

m =

- (o) (i) With the meter rule outside the beaker, measure the height  $h$  of the water meniscus above the bench.

Determine the value of  $P$  given that  $P = \frac{5}{\sqrt{h}}$

(1 mk)

Hence determine the value of  $f$  given that  $f = \frac{P}{2m} + 1$  to one decimal place

(2 mks)

### Question two

You are provided with the following:

- an ammeter a voltmeter
- two cells (size D)
- a cell holder a switch
- a wire labelled L mounted on a millimetre scale
- a micrometer screw gauge (to be shared)
- six connecting wires at least four with crocodile clips

Proceed as follows:

- (a) Using a micrometer screw gauge, measure and record the diameter  $d$  of the wire L. (1 mk)

$d = \dots\dots\dots$  mm

$d = \dots\dots\dots$  m.

- (b) Place the two cells in series in the cell holder and use the voltmeter to Measure the total electromotive force (emf)  $E_0$  of the battery. (1 mk)

$E_0 = \dots\dots\dots$  V

- (c) Starting with the switch open, connect the circuit as shown in figure 5.  $P$  and

Q are

points on the wire L such that PQ is 60 cm. (PQ should remain 60 cm throughout the

experiment) N is a point on the wire such that PN is 10 cm (0.1 m) .

(i) Close the switch and record the current I.

(1 mk)

I = ..... A.

(ii) Measure and record in table 2 the potential difference across PN.

(1 mk)

(iii) Measure and record the potential difference across PN for the other values of PN shown in table 2 and complete the table. (*The current is expected to remain constant*) Hint: The switch should be closed only when reading the voltmeter.

TABLE 2

Length PN (m)	0.1	0.2	0.3	0.4	0.5	0.6
p.d (v)						
Resistance $\frac{V}{I} \Omega$						

(6 mks)

(e) On the grid provided, plot a graph of resistance (y-axis) against length

(3 mks)

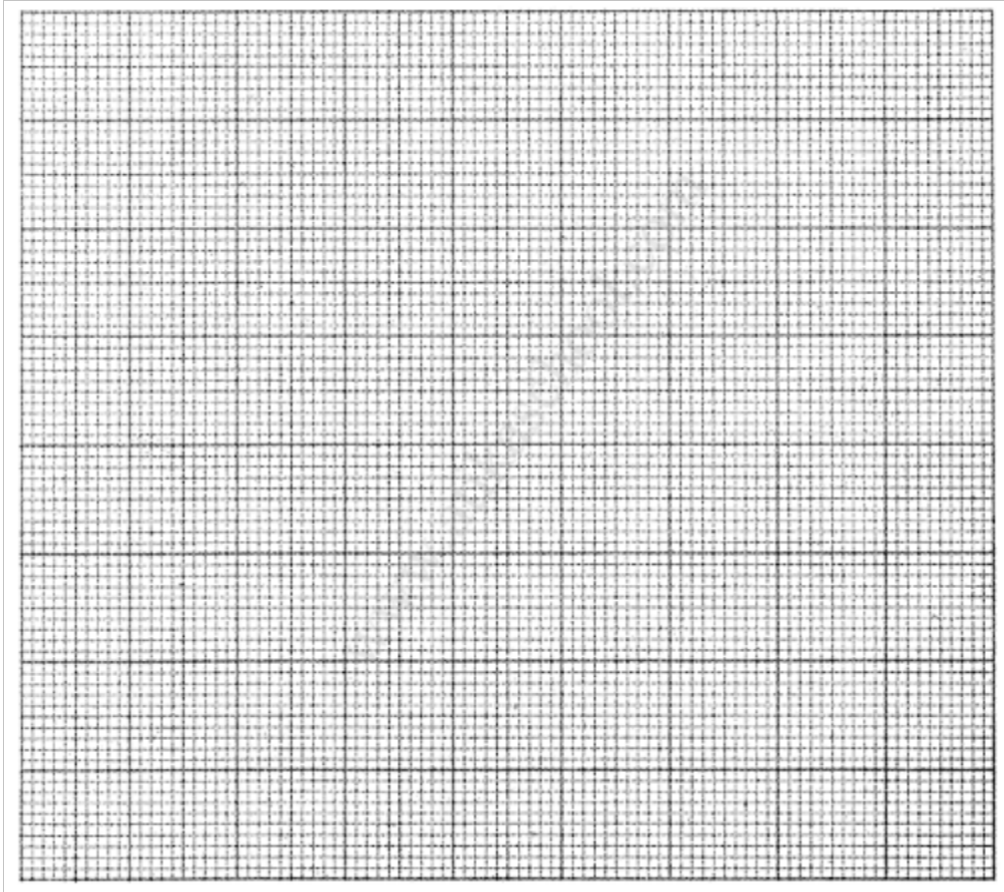

(f) From the graph, determine:

(i) the slope  $S$  and its units.  
(3 mks)

(ii) the constant  $k$  and its units given that (2 mks)

$$S = \frac{4k}{\pi d^2}$$

(g) Determine constant  $t$  given that

$$t = \frac{E_0 - V_0}{I}$$

where  $V_n$  is the p.d at PN = 0.6 m

(2 mks)



*'an investment of knowledge pays*

The following KASNEB notes are available;

 **ATD**

 **CPA**

 **CS**

 **CIFA**

**Call Mdm.Mariam;0746711892 to acquire them**

