

# PHYSICS PAPER 2 KCSE PAST PAPERS (1995-2016)

For marking schemes, contact/Whatsapp-0746711892



'an investment of knowledge pays'

For marking schemes, prefer calling Mdm Mariam:0746711892  
Other available resources are;

📌 well summarised primary and secondary notes

📌 FI-F4 termly exams

📌 primary exams

📌 KCSE past papers

📌 KCPE past papers

📌 Mocks

📌 lesson plans

📌 schemes of work

Note: Exam questions are always free of charge

Marking scheme are not free

**K.C.S.E 1995**  
**PHYSICS PAPER 232/2**  
**QUESTIONS**

**SECTION 1 (65 MARKS)**

*Answer all the questions in this section in the spaces provided*

1. The data in the table below represents the motion of vehicle over a period of 7 seconds

Time (sec)	0	1	2	3	4	5	6	7
Displacement	0	20	40	60	80	95	105	110

- (a) plot on the grid provided, a graph of displacement (y- axis) against time (5 mks)
- (b) Describe the motion of the vehicle for the first 4 s (1 mk)
- (c) Determine the velocities at 4.5s and 6.5s. Hence or otherwise determine the average acceleration of the vehicle over this time interval
2. Study the circuit diagram in figure 1 and answer the following questions

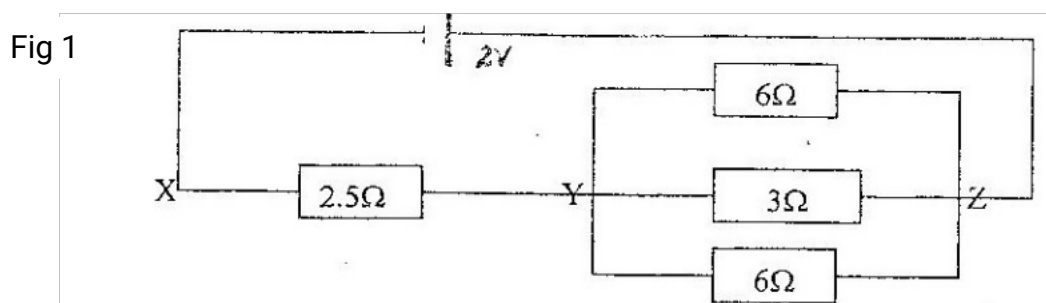

- (a) Calculate the effective resistance between Y and Z (3 mks)
- (b) Determine the current through the  $3\Omega$  resistors (6 mks)

- (c) One of the  $6\Omega$  resistor has a length of 1.0m and cross –section area of  $5.0 \times 10^{-6} \text{ m}^2$  ( 3 mks)

Calculate the resistivity of the material

3. (a) An object O is placed in front of convex mirror as shown in figure 2

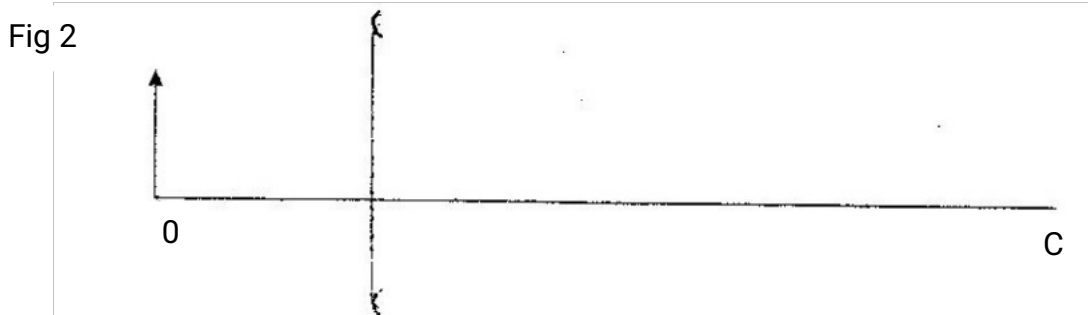

- (i) Draw to scale a ray diagram to show the position of the image ( 5 mks)

- (ii) Determine the magnification ( 3 mks)

- (b) An object placed in front of a convex lens of focal length 10 cm produces an image at a distance of 15 cm from the lens and on the same sides as the object

Determine the position of the object ( 4 mks)

4. (a) Draw a ray diagram to show how a convex lens works as a magnifying glass ( 5 mks)
- (b) The diagram in figure 3 shows a certain eye defect

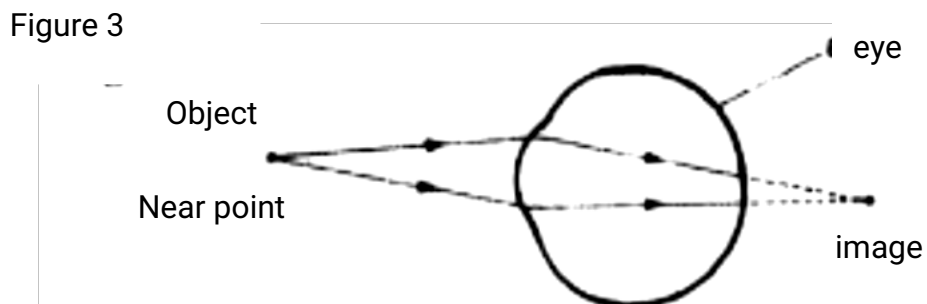

- (i) Name the object

- (ii) Draw on the same diagram an arrangement to correct the defect ( 1 mk)
- (c) (i) Explain why a pail of water can be swung in vertical circle without the water pouring out ( 3 mks)
- (ii) A car of mass 1200kg is moving with a velocity of  $25\text{ms}^{-1}$  around a flat bend of radius 150m. Determine the minimum frictional force between the tyres and the road that will prevent the car from sliding off. ( 4 mks)
5. (a) (i) State the law of electromagnetic induction ( 2 mks)
- (ii) Describe an experiment to demonstrate Faraday's law ( 4 mks)
- (b) (i) A researcher studying the behaviour of step- up transformer made the following observations:  
*"More joules per coulomb and fewer coulombs per second at the output than at the input terminals"*
- Explain why the observation does not imply a violation of the principle of conservation of energy ( 4 mks)
- (ii) A transformer of 480 turns in the primary coil is used to connect a 9 volt a.c electric device to a 240 v.a.c mains power supply. Calculate the number of turns in the secondary coil. ( 3 mks)

### SECTION II (15 MARKS)

*Answer one question from this section*

6. (a) Distinguish between stationary and progressive waves (1mk)
- (b) (i) describe how a young's double slit may be made in a laboratory (2mks)
- (ii) State the condition for a minim to occur in an interference pattern (1mk)
- (c) The sketch graph in fig 4 shows the results of an experiment to study diffraction patterns using a double slit.

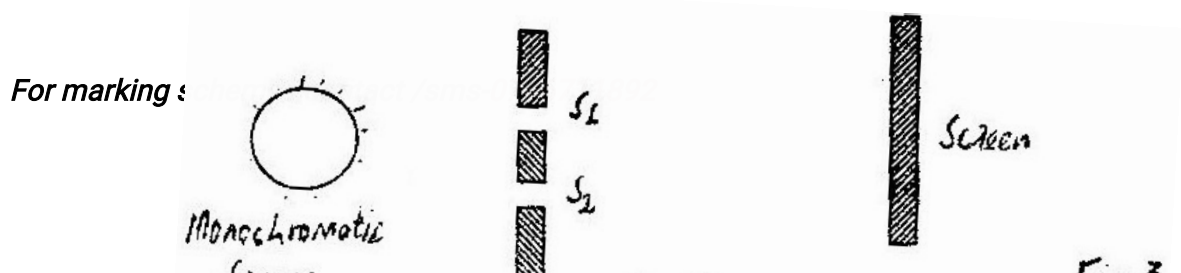

Screen

Monochromatic source

Double slit

Fig 3

- (i) Sketch an experimental set up that can be used to obtain such a pattern ( 4 mks)
- (ii) Name an instrument for measuring the intensity ( 1 mk)
- (iii) Explain how the peaks labeled A and B, and troughs labeled C are formed ( 6 mks)
7. (a) Describe how a p- type semi conductor is formed ( 3 mks)
- (b) Distinguish between p- n- p and n – p – n transistors ( 1 mk)
- (c) The sketch in the fig 5 shows the results of an experiment where a transistor was used as a voltage amplifier

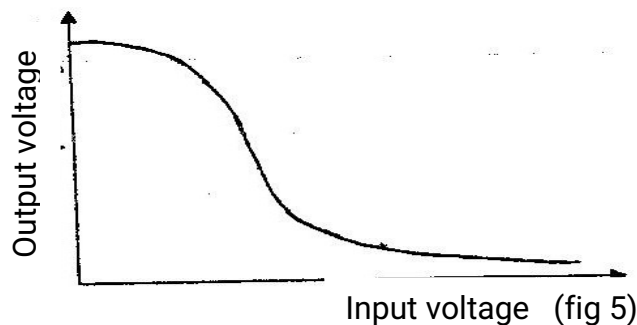

Explain how the voltage amplification factor,  $\beta$ , may be obtained from the sketch graph ( 4 mks)

- (d) (i) Draw a circuit diagram of p – n – p transistor operating in the common emitter ( C-E) mode indicate on the diagram the directions of the collector current  $I_c$  the base current  $I_B$  the emitter current  $I_E$  ( 4 mks)
- (ii) Write the equation relating  $I_c$   $I_B$   $I_E$  ( 1mk)

(e) Identify the type of biasing in each of the junctions of a transistor in operation  
( 2 mks)

**K.C.S.E 1996**  
**PHYSICS PAPER 232/2**  
**QUESTIONS**

**SECTION 1 (65 MARKS)**

*Answer all the questions in this section in the spaces provided*

1. (a) A accelerates uniformly from its initial velocity,  $u$ , the final velocity,  $v$  in time  $t$ . The distance traveled during this time is  $S$ . If the acceleration is denoted by the letter,  $a$  show that;

(i)  $V = u + at$  (2 mks)

(ii)  $S = ut + at^2$  (3 mks)

(iii)  $V^2 = u^2 + as$  (2mks)

- (b) A body moving initially at  $50\text{m/s}$  decelerates uniformly at  $2\text{ms}^{-2}$  until it comes to rest. What distance does it cover from the time it started to decelerate (3 mks)

2. (a) Given a bar magnet, an iron bar and a string
- (i) Describe a simple experiment to distinguish between the magnet and the iron bar (4 mks)
- (ii) State with reasons the observation that would be made in the experiment (4 mks)

- (b) In an experiment to magnetize two substances P and Q using electric current, two curves (graphs) were obtained as shown in figure 1

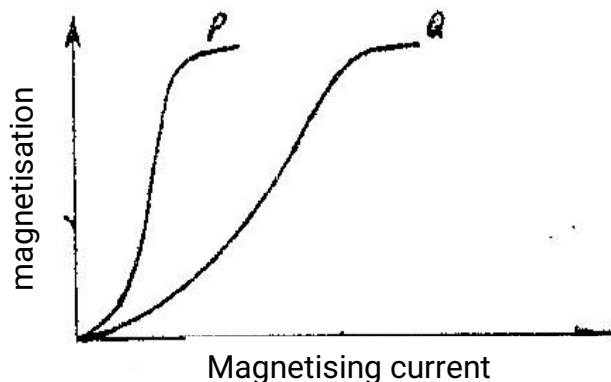
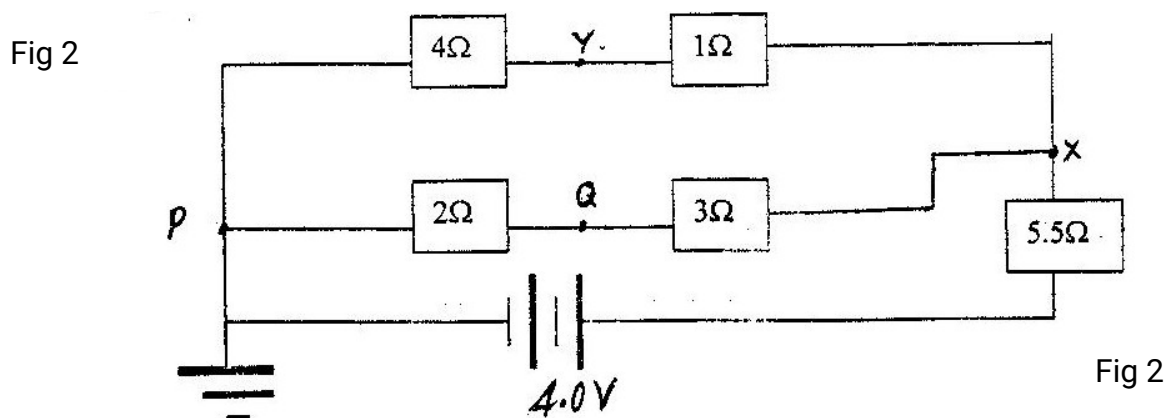

Fig 1

Using the information in Fig 1 explain the difference between the substances P and Q with references to the domain theory  
(6 mks)

3. The diagram in fig 2 represent an electric circuit in which five resistors are connected to be a battery of e.m.f 4.0 V and of negligible internal resistance



Determine:

- (i) The total resistance of the circuit  
(3 mks)
- (ii) The potential difference between Y and Q  
(2 mks)
4. (a) (i) Describe the experiment to determine the specific heat capacity  $C$ , of a block of aluminium with two holes drilled in it, to accommodate a thermometer and an electric immersion heater  
(2 mks)
- (ii) State the measurements required in the experiment and show how they would be used to obtain  $C$   
(5 mks)
- (iii) State two precaution that should be taken in this experiment  
(2 mks)
- (b) A copper calorimeter of mass 60g is filed with 100g of water at  $25^{\circ}\text{C}$ . Steam at a normal temperature and pressure (N.T.P) is passed through the water until a temperature  $45^{\circ}\text{C}$  is attained. The final mass of calorimeter and the contents was found to be 163.5g. Calculate the specific latent heat of vaporization ' $l$ ' of water  
(6 mks)



Specific heat capacity for water is  $4200\text{Jkg}^{-1}$  and for copper is  $378\text{Kg}^{-1}\text{K}^{-1}$

5. (a) (i) What is the difference between longitudinal and transverse waves?  
(1 mk)
- (ii) State two distinctions between the way sound waves and electromagnetic waves are transmitted  
(2 mks)
- (b) A mineworker stands between two vertical cliffs 400m from the nearest cliff. The cliffs are X distance apart. Every time he strikes the rock once, he hears two echoes, the first one after 2.5 s, while the second follows 2s later. From this information; calculation:
- (i) The speed of the sound in air  
(2 mks)
- (ii) The value of X  
(3 mks)
- (c) In an experiment to observe interference of light waves a double slit is placed close to the source. See figure 3

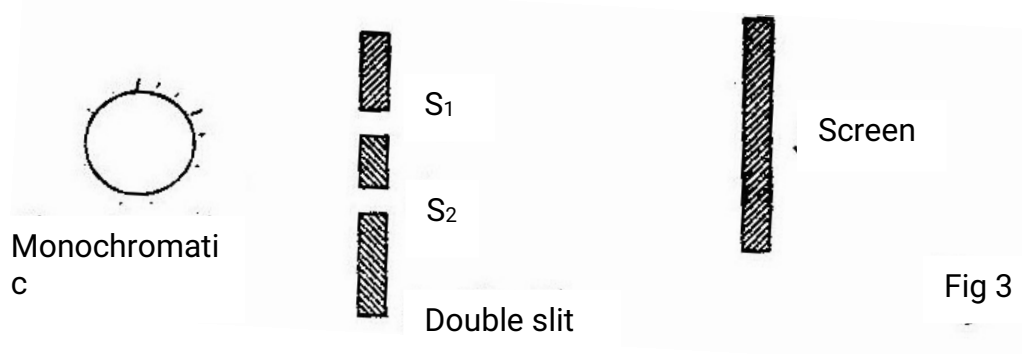

- (i) State the function of the double slit  
(1 mk)
- (ii) Describe what is observed on the screen  
(2mks)
- (iii) State what is observed on the screen when
- I. The slit separation  $S_1S_2$  is reduced  
(1 mk)
- II. White light source is used in place of monochromatic source  
(1 mk)

**SECTION II (15 MARKS)**

*Answer any two question from this section*

6. (a) The fig. 4 shows the diagram of set up to investigate the variation of centripetal with the radius  $r$ , of the circle in which a body rotated

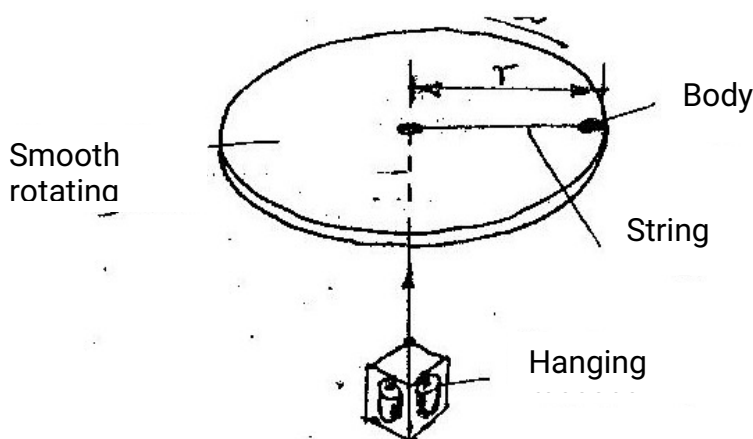

Fig 4

Describe how the set up can be used to carry out the investigation (5 mks)

Table 1

Mass, $m$ (g)	60	50	40	30	20
Radius, $r$ (cm)	50	41	33	24	16

Table 1 shows results obtained from an investigation similar to the one in part (a)

- (i) Plot a graph of force,  $F$  (y-axis) on the body against the radius,  $r$ , (in meters) (5mks)
  - (ii) Given that the mass of the body is 100g, use the graph to determine the angular velocity, (5 mks)
7. (a) Describe with the aid of a diagram an experiment set up for observing photoelectric effect

- (b) Table 2 shows the relationship between the wavelength,  $\lambda$  of a radiation falling on the surface and the energy,  $k$  of the emitted electrons

$\lambda(\text{m}) * 10^{-7}$	20	1.5	1.0	0.5
$K(\text{J}) * 10^{-19}$	10	13	20	40

- (i) Plot a graph of energy  $k$  (y – axis) against the frequency,  $f$ , of the incident light
- (ii) Determine the work function  $\Phi$  of the surface used (5 mks)  
Speed of light,  $c = 3.00 * 10^8 \text{ ms}^{-1}$  planks constant  $h = 6.663 * 10^{-34} \text{ JS}$

## K.C.S.E 1997 PHYSICS PAPER 232/2 QUESTIONS

*Answer all the questions in section I and any one in section II*

*Take: specific heat capacity of water =  $4200 \text{ Jkg}^{-1} \text{ K}^{-1}$*

*Latent heat of melting ice =  $334,000 \text{ Jkg}^{-1} \text{ K}^{-1}$*

*Planck's constant  $h = 3.34 * 10^{-34} \text{ JS}$*

*Speed of light,  $c = 3.0 * 10^8 \text{ ms}^{-1}$*

1. Figure 1 shows a circuit diagram for controlling the temperature of a room.

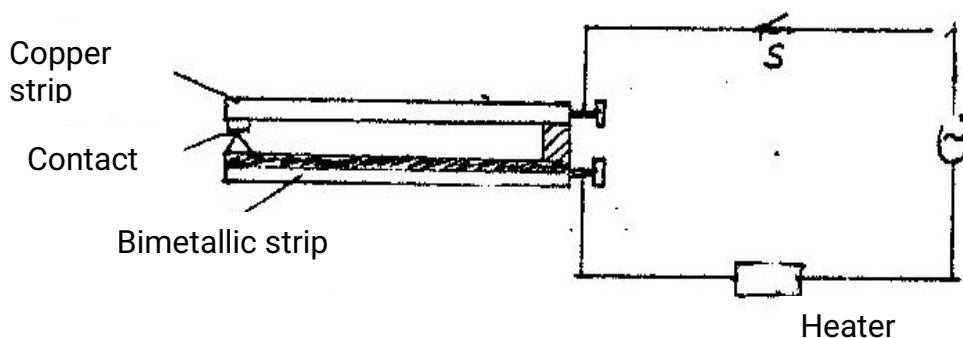

Fig 1

- (i) State and explain the purpose of the Bimetallic strip
- (ii) Describe how the circuit controls the temperature when the switch is closed

- (b) A drinking glass 0.02 kg contains 200gms of water at  $20^{\circ}\text{C}$ . A mass of 0.04 kg of ice at  $0^{\circ}\text{C}$  is dropped into the glass. Determine the final temperature of the mixture. Specific heat capacity of glass =  $670 \text{ kg}^{-1} \text{ K}^{-1}$ . (Give your answer to correct one decimal place)

2. (a) Figure 2 shows a uniform plank 20 m long, weighing 400N resting on two

supports A and B 9m apart. A person weighing 600N walks towards B starting at A.

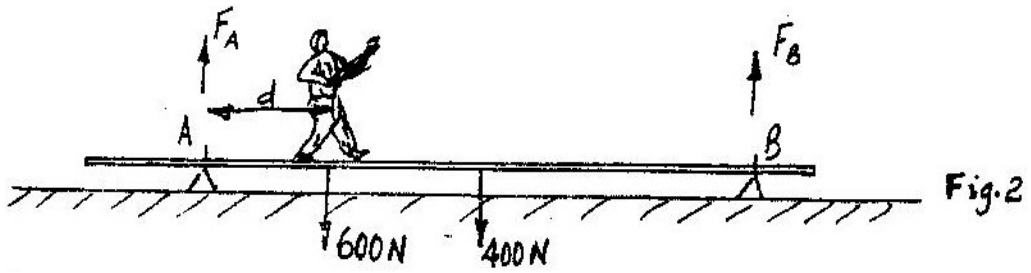

The data in the table below represents the upward force  $F_A$  exerted at A as a function of distance,  $d$ . The distance  $d$  is measured from A.

D (m)	0	2	4	6	8	10
$F_A$ (N)	800	650	500	350	200	50

(i) On the grid provided plot a graph of  $F_A$  (y – axis) against the distance  $d$ .

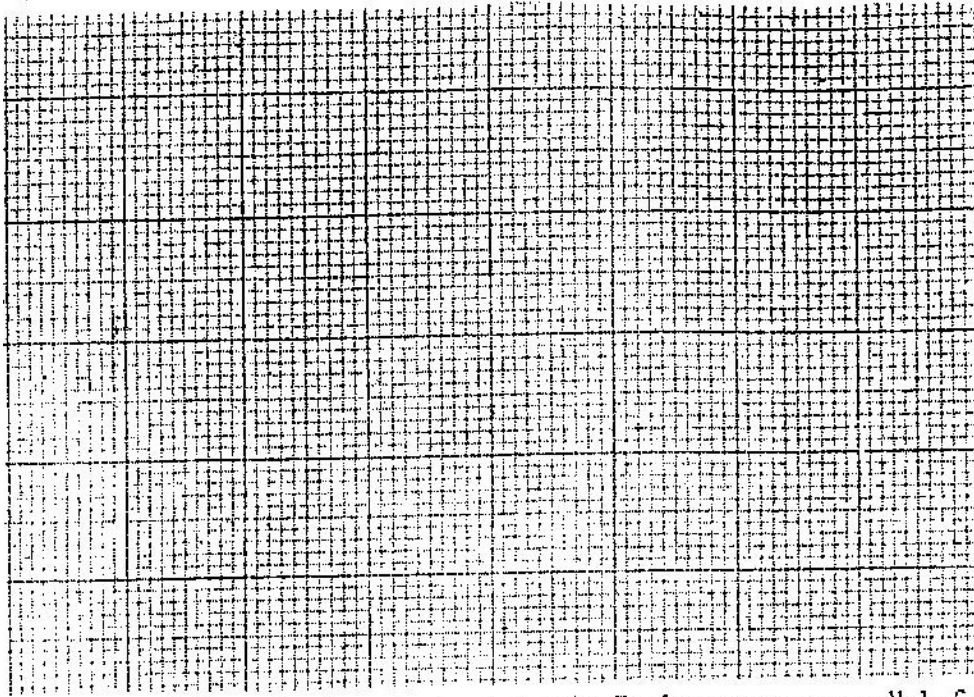

(ii) From the graph determine how far beyond point B, the person can walk before the plank tips

(b) In the set up in the figure 3, the metre rule is in equilibrium

For mark

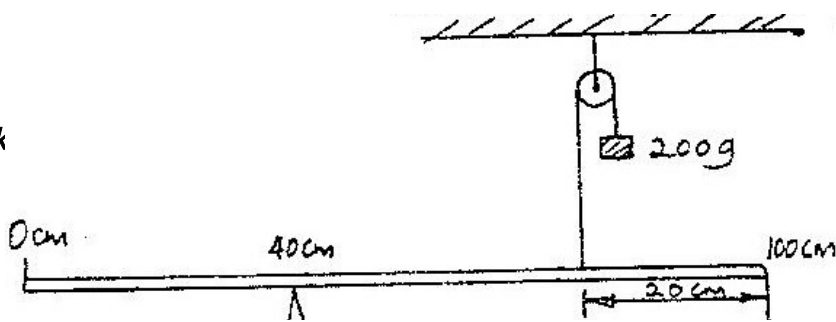



100 Fig. 3

Given that the metre rule is uniform, determine its weight

3. (a) A stone is thrown vertically upwards from the edges of a platform. Eventually the stone lands without bouncing on the ground below the platform. Taking the upward velocity to be positive sketch on the axis provided the velocity time graph of the motion of the stone.



- (b) A car can be brought to rest from a speed of  $20 \text{ ms}^{-1}$  in a time of 2s

(i) Calculate the average deceleration

(ii) If the driver's reaction time is 0.2s, determine the shortest stopping distance

4. Figure 4 shows a force-distance graph for a car being towed on a horizontal ground

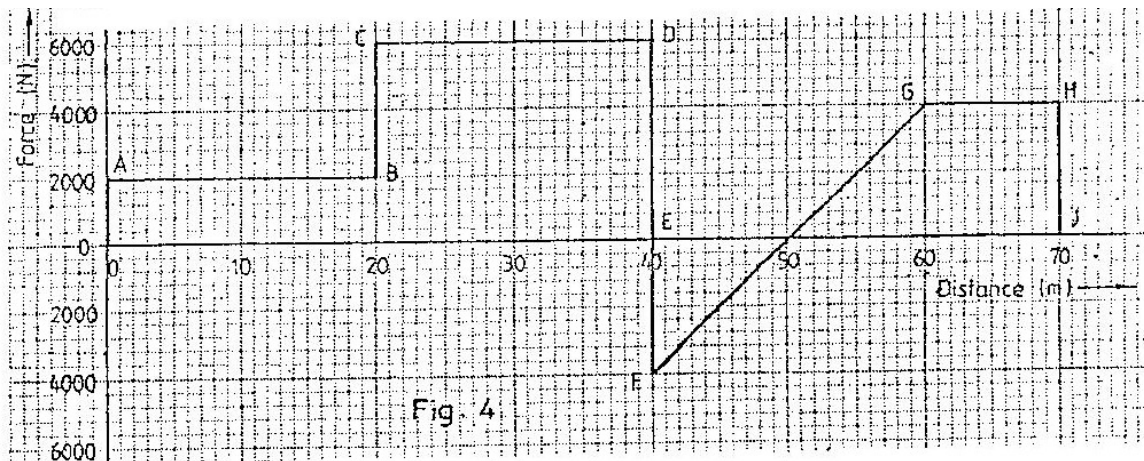
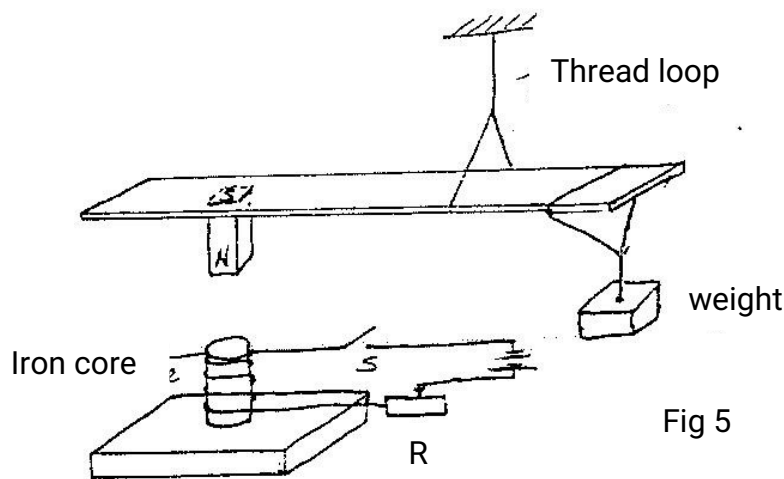

Fig. 4

- (a) Calculate the total work done
- (b) If the velocity just before reaching point D is  $0.6\text{ms}^{-1}$ , calculate the power developed by the agent providing the force at this point.
- (c) An electric pump can raise water from a low level reservoir to the higher – level reservoir at the rate of  $3.0 \times 10^5$  kg per hour. The vertical height of the water raised 360m. If the rate of energy loss in form of heat is 200KW, determine the efficiency of the pump

5. (a) State two factors that affect the strength of an electromagnet.
- (b) In the set up in figure 5, the suspended metre rule is in equilibrium balanced by the magnet and the weight shown. The iron core is fixed to the bench.



- (i) State and explain the effect on metre rule when the switch S is closed
  - (ii) What would be the effect of reversing the battery terminals
  - (iii) Suggest how the set up in figure 5 can be adapted to measure the current flowing in the current circuit.
- (c) Electrons emitted from a metal when light of a certain frequency is shone on the metal are found to have a maximum energy of  $8.0 \times 10^{-19}\text{J}$ . If the work function of the metal is  $3.2 \times 10^{-19}\text{J}$ , determine the wavelength of the light used.

## SECTION II

6. (a) (i) Distinguish between semiconductor and conductors  
Semiconductors                      Conductors
- (ii) Give one example of a semiconductor and one for a conductor  
Semiconductors                      Conductors
- (b) An **npn** transistor is operating in the common emitter mode
- (i) Draw the circuit diagram and indicate the direction of the currents
- (ii) Given that the emitter current is 2.0 m A and that 0.5% of the electrons diffusing into the base combine there with holes, determine the values of the base current and the collector current
- (ii) By increasing the p.d across the emitter – base junction in (ii), the emitter current increase to 4mA. Determine the transistor current amplification
7. a) i. Distinguish between transverse and longitudinal waves  
ii. Give one example of a transverse and one example of longitudinal.

- b) Figure 6 shows the displacement of a particle in a progressive wave incident on a boundary between deep and shallow regions.

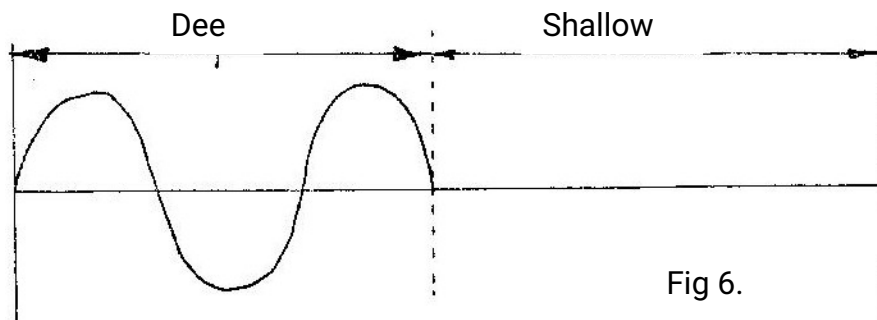

- i. Complete the diagram to show what is observed after boundary.  
(assume no loss of energy)
- ii. Explain the observation in (i) above.
- (c) Water waves are observed as they pass a fixed point at a rate of 30 crests per minute. A particular wave crest takes 2s to travel between two fixed points 6m apart. Determine for the wave:

(a) The frequency (1mk)

(b) Wavelength

(3mks)

- (d) Figure 7 shows two loud speakers  $L_1$  and  $L_2$  connected to a signal generator

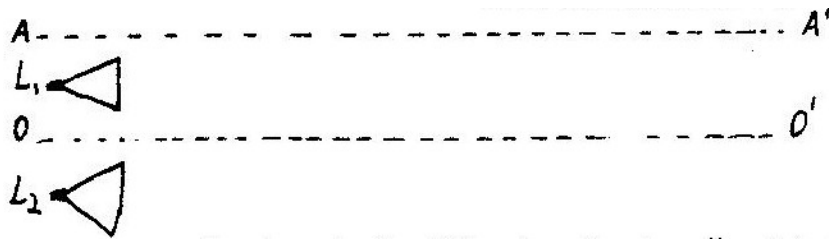

One observer walks along line  $OO'$  and another line  $AA'$  for some distance. Describe the observations made by each observer and give reasons for your answer.



# K.C.S.E 1998

## PHYSICS PAPER 232/2

### QUESTIONS

- 1.a) In an experiment to determine the strength of an electromagnet, the weight of pins that can be supported by the electromagnet, was recorded against the number of turns. The current was kept constant throughout the experiment. Table 1 shows the data obtained.

Number of turns, n,	0	4	8	12	16	20	24	28	32	36
Weight, of pins $\times 10^{-3}$ (N)	0	4	14	30	58	108	198	264	296	300

Table 1

- (i) Plot a graph of weigh, W (y-axis) against the number of turn's n
  - (ii) Use the domain theory to explain the nature of the curve.
  - (iii) Sketch on the same axes, the curve that would be obtained using a higher current.
- b) Using a labeled diagram, explain the working of a simple relay.
2. a) You are provided with two straight open tubes each about 1m long, a sound source, a sound detector and a reflecting surface. With the aid of a labeled diagram, describe an experiment to show that the angle of incidents is equal to reflection for sound waves.

- b) Fig. 1 shows a block with a graduated side, and of dimension 4cm x 4cm x 4cm x 16cm, just about to be lowered into a liquid contained in an overflow can.

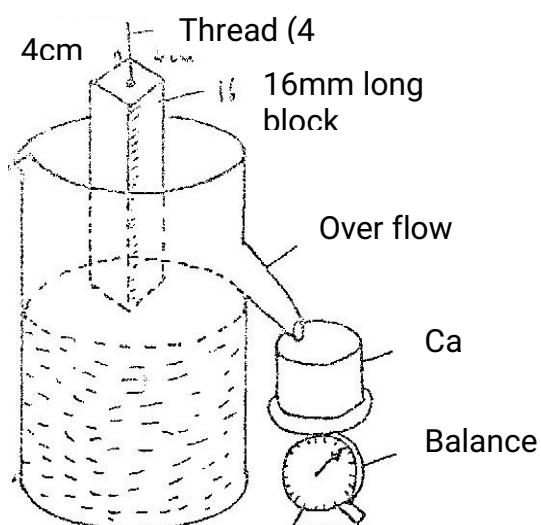

fig 1

During an experiment with this set-up, the following information was recorded;  
 -The block floated with three quarters of it submerged  
 -Initial reading of balance=0 grammes  
 -final reading of balance= 154 grammes.

Use the information to determine the density of the:

- (i) Block (ii) Liquid

(Use  $g = 10 \text{ms}^{-2}$  . give your answers to 1 decimal place.)

3 a) A gun is fired vertically upwards from the top of 2 open truck moving horizontally at a uniform velocity of  $50 \text{ms}^{-1}$ . The bullet achieves a maximum height of 45m. State with reason whether or not the bullet will land on the truck.

(i) Calculate the distance covered by the truck just before the bullet reaches the level from which it was fired. (Use  $g = 10 \text{ms}^{-2}$ )

b) Figure 2 shows a set-up that may be used to verify Boyle's law.

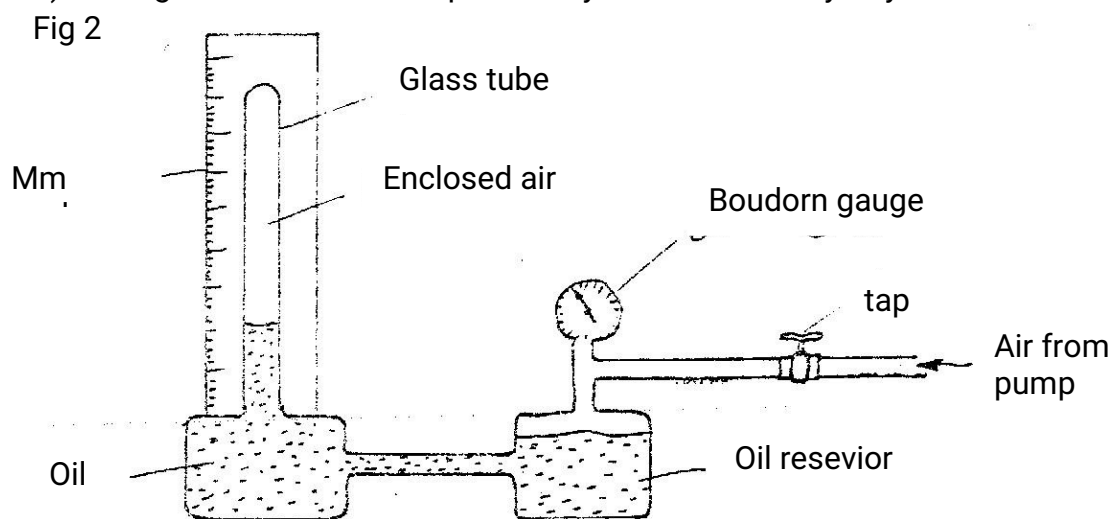

Fig 2

- i) Describe the measurements that should be taken in the experiment  
 ii) Explain how the measurements taken in (i) above may be used to verify Boyle's law.

- 4 a) In an experiment to determine the rate at which solar energy is absorbed by a surface, an aluminum block, coated black and fitted with a heater (Fig. 3) is exposed to the sun, for a period of time. The temperature rise is noted. After the temperature of the block is allowed to fall to the initial temperature, the block is electrically heated to the temperature.

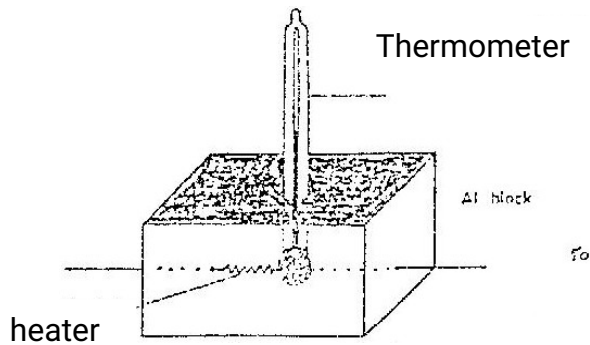
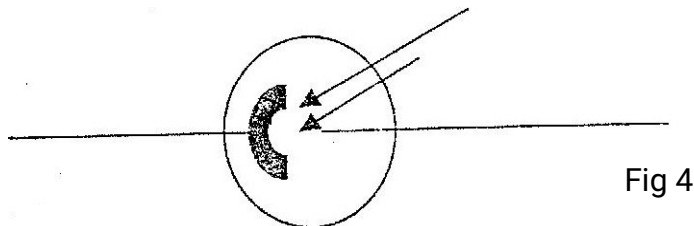

Fig. 3

- (i) Draw and labeled a circuit diagram that would be used to determine the electrical energy.
- (ii) State the measurements that would be taken in (a)(i) to determine the rate of heating of the block.
- (iii) Explain how the measurements stated in (a) (ii) would be used to determine the rate of heating of the block by the sun.
- b) Fig 4 shows a photocell



- (i) Label the cathode and anode.
- (ii) How are electrons produced in the cell/
- (iii) Draw a simple circuit including the photocell to show the direction of flow of current
- (iv) Calculate the photon energy in ultraviolet radiation whose frequency

is  $8.60 \times 10^{14}$  Hz. (Plank's constant  $h=6.63 \times 10^{-34}$  Js)

5. a) A ray of white light is incident on one face of a rectangular glass prism.
- Draw a ray diagram to illustrate the dispersion of white light by the prism, showing only the red (R) and violet (V) rays.
  - On the same diagram drawn in (i) mark and label the initial angle of incidence,  $i$ , and the angles of refraction on the first face for red  $r_R$  and for violet  $r_V$ .
  - Snell's law for the red and colours can be written as  

$$n_r = \frac{\sin i}{\sin r_R}$$
- b) Calculate the critical angle for a material whose refractive index is 1.40.

### SECTION II

6. Fig 5 shows a circuit for charging and discharging a capacitor; e, through a variable resistor R, X Y and T are points on a two-way switch.

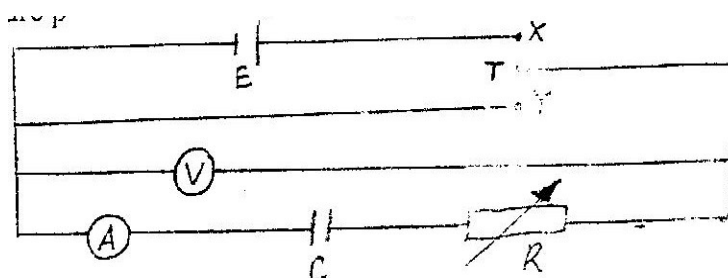

Fig. 5

- Explain how the charging and discharging processes are achieved.
- Table 2 show the variation of the charge  $q$  with time  $t$  when a  $500 \mu\text{F}$  capacitor was discharged through a resistor.

Time, $t$ , (s)	0	20	40	60	80	100
Charge, $q$ ( $\mu\text{C}$ )	300	150	75	38	19	10

Table 2

- Plot a graph of charge  $q$  (y axis ) against time.
  - Determine the current flowing in the circuit at  $t = 30\text{s}$ . (Give your answer to 1 decimal place)
7. a) Fig. 6 shows an object,  $0.3\text{cm}$  high placed in front of a concave mirror. C is the centre of curvature of the mirror. The diagram is drawn to scale: (1cm: 2cm)

Draw a ray diagram, on figure 6, and determine the size of the image produced.

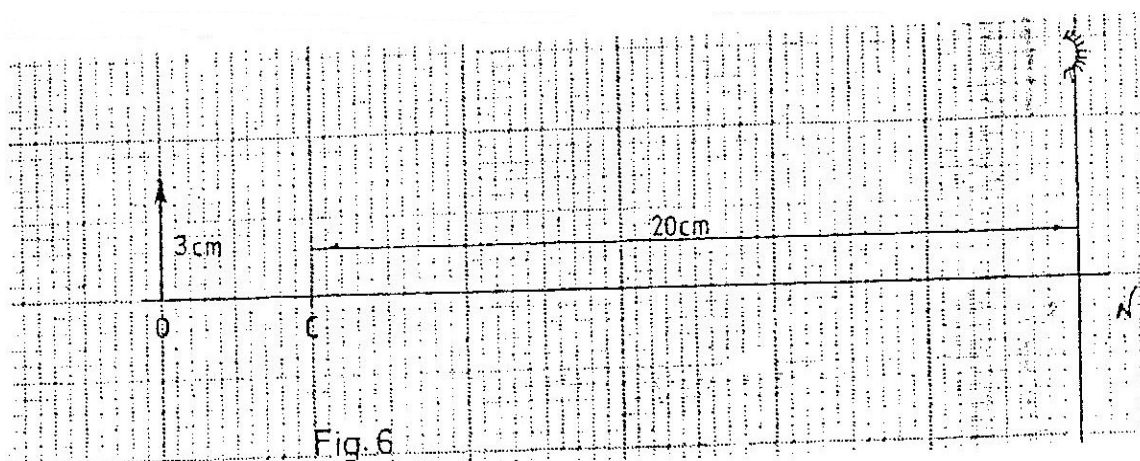

- b) Table 3 shows the object distance  $u$  and the corresponding image distance  $v$ , for an object placed in front of a concave mirror.

$U(\text{cm})$	20	25	30	40	50	70
$V(\text{cm})$	20	16.7	15	13.3	12.0	11.6
$1/v(\text{cm}^{-1})$						
$V(\text{cm}^{-1})$						

Table 3

- i) Complete the table and plot a graph of  $1/v$  (y-axis) against  $1/u$  (give your answers to 3 decimal places).
- ii) From the graph, determine the focal length of the mirror.

**K.C.S.E 1999**  
**PHYSICS PAPER 232/2**  
**QUESTIONS**

1 a) Distinguish between longitudinal and transverse waves  
 Longitudinal waves -                      Transverse waves -

b) In the Young's double slit experiment, an interference pattern of bright and dark fringes was formed as shown in figure 1 by a light of wavelength  $\lambda$  coming from two narrow slits X and Y.

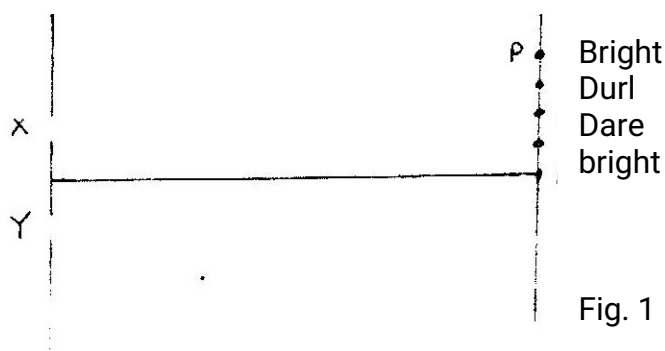

- i) Write an expression for the path difference between XP and YP where P corresponds to the 2<sup>nd</sup> bright fringe.
- ii) Explain how the dark and bright fringes are formed.
- iii) State and explain what would be observed on the screen if the slits X and Y were made large.

c) Figure 2 represents a displacement – time graph for a wave.

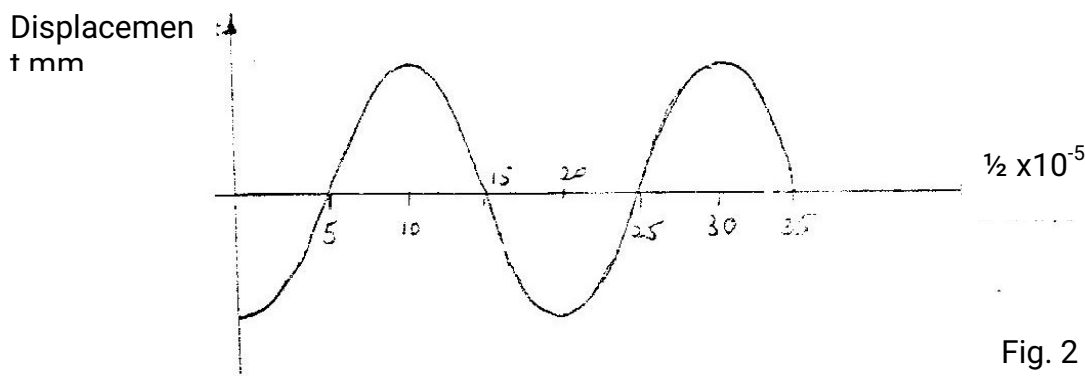

- i) Determine the frequency of the wave.
- ii) Sketch on the same axes, the displacement – time graph of a wave of the same frequency but 180° out of phase and with a smaller amplitude.

- 2 a) An object O placed in front of a converging lens  $L_o$  forms an image 1 on the other side of the lens. Another converging lens  $L_c$  placed such that the two lenses form a compound microscope.
- Draw a reason of the set up and sketch the rays to show how the final image is formed.
  - Give a reason why the focal length of  $L_o$  must be greater than that of  $L_c$ .
- b) An object is placed 30cm from a converging lens. A focused image is formed on a screen placed 30cm from the same lens on the other side. The screen is now moved 5cm towards the lens. Determine the distance the object must be moved so that a focused image is formed on the screen.
3. A tape attached to a moving trolley is run through a ticker timer. Figure 3 shows a section of the tape after running.

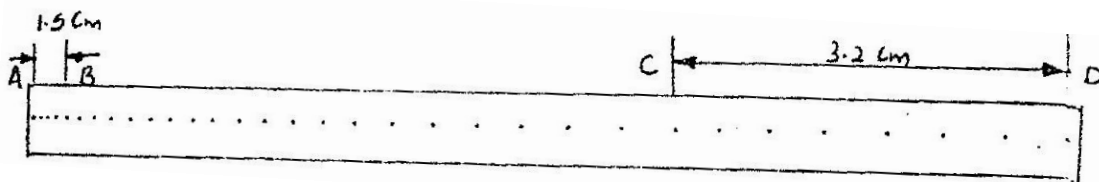

**Figure 3.**

If the frequency of the ticker – timer is 50Hz, determine the:

- Average velocity at intervals AB and CD.
  - A average acceleration of the trolley.
- b) A stone is released from a height, h. if the acceleration due to gravity is g, derive an expression of the velocity of the stone just before hitting the ground.
- c) Figure 4 (a) shows a velocity – time graph of an object in motion.

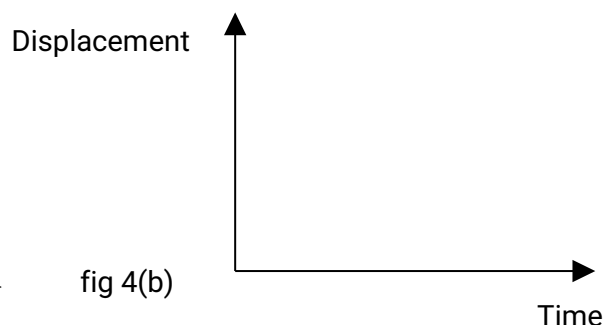
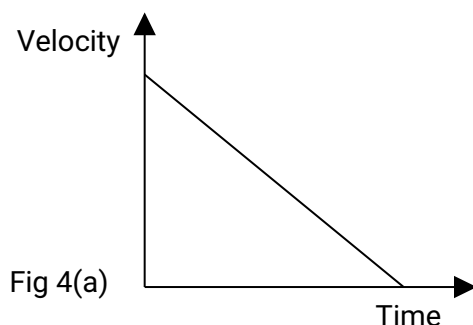

Sketch on the axes provided in figure b4 (b0, the displacement – time graph of the Motion (Motion upwards is taken as positive).

4. Figure 5 represents a simple voltage amplifier circuit.

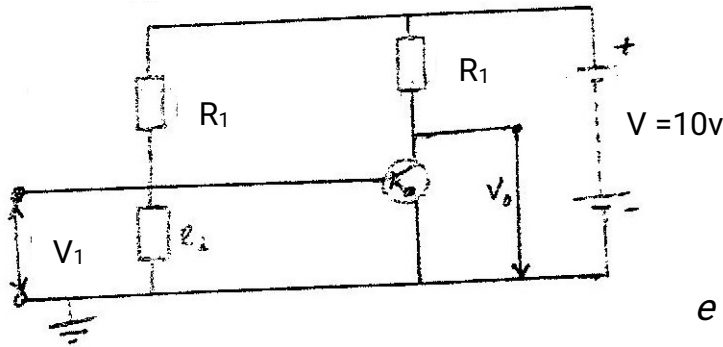

**Figure 5**

- a)
- i) Identify the transistor in the circuit.
  - ii) Explain how the base bias is produced.
  - iii) Describe how an alternating signal that is fed in the input  $V_1$  is amplified.
- b) When a signal is fed in the input, the collector current is 2.5mA. If the current gain is 62.5 and the voltage across the transistor ( $V_{CE}$ ) is 4.5V determine the :
- i) Power rating of the heater
  - ii) Current flowing in the circuit.
- 5a) A circuit consists of a battery, a metal wire, an ammeter and a switch connected in series. The switch is closed and the ammeter reading noted. The metal wire is now heated. State the observations made on the ammeter reading and give a reason for your answer.
- b) An electric heater is made of a wire of resistance  $100\Omega$  and connected to a 240V mains supply. Determine the:
- i) Power rating of the heater
  - ii) Current flowing in the circuit.
  - iii) Time taken for the heater to raise the temperature of 200g of water from  $23^\circ\text{C}$  to  $95^\circ\text{C}$ . (Specific heat capacity of water is  $4200\text{J K}^{-1}$ )
  - iv) Cost of using the heater for two hours a day for 30 days. (The power and lighting company charges Kshs 5.00 per kilowatt – hour).

## SECTION II

- 6a) Explain the following observations: ice cube float on water and solid benzene sinks in liquid benzene.
- b) You are provided with the following:  
 -An overflow can    - A beaker    -A spring balance



- A metal block
- Water and
- String

Describe an experiment to verify Archimedes principle.

- ii) A block of wood weighing 2.0N is held under water by a string attached to the bottom of a container. The tension in the string is 0.5N. Determine the density of the wood.

C i) Define half – life of a radioactive material.

- ii) Figure 6 shows a graph of the variation of the number of atoms of a certain radioactive material with time.

Figure6: Determine the half – life of the material

7a) Figure 7 shows a photoelectric cell circuit:

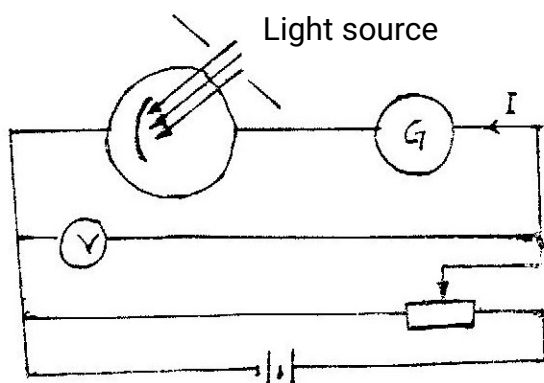

Fig. 7

The intensity of the light can be varied.

- i) Describe how the circuit may be used to show how the current  $I$  varies with the potential difference  $V$  across the cell.
- ii) Sketch on the same axis graphs of  $I$  versus  $V$  for three different values of light intensity  $E_1, E_2$  and  $E_3$  such that  $E_3 > E_2 > E_1$
- b) Using a circuit similar to the one in figure 7. with the polarity of the batteries reversed, the frequency, of the light was varied at constant intensity. For each frequency, the potential difference was varied until the current was equal to zero. The value of this voltage,  $V_{\infty}$  was noted. The graph in figure 8 shows the relation between  $V_{\infty}$  and the frequency, of the incident light. From the graph, determine the:
- i) Value of planks constant,  $h$  (charge an electron  $e = 1.6 \times 10^{-19}$  Colubomb)

- ii) Work function,  $\phi$ , of the cathode surface of the cell . (Give your answers to 2 decimal places.)

**K.C.S.E 2000**  
**PHYSICS PAPER 232/2**  
**QUESTIONS**

- 1a) i) State one application of each of the following.  
 Convex mirror-      Parabolic mirror –
- ii) Fig. 1, which is drawn to a scale of 1:5, represents an object O and its image 'I' formed by a concave mirror.

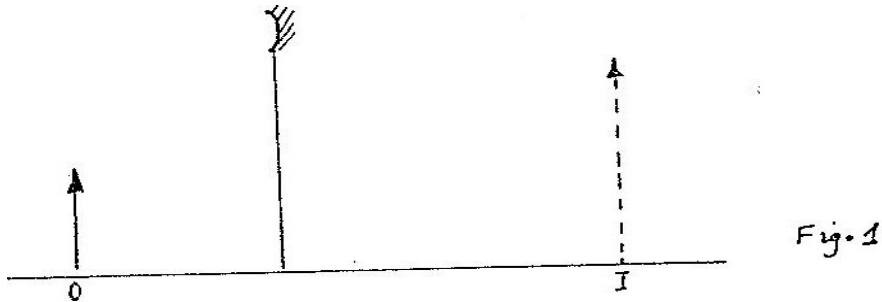

By drawing suitable rays, locate and mark on the figure the position of the principal focus 'F' of the mirror. Determine the focal length  $f$ .

- b) The graph in Fig. 2 shows the variation of magnification,  $M$  with image distance,  $v$  for a concave mirror.

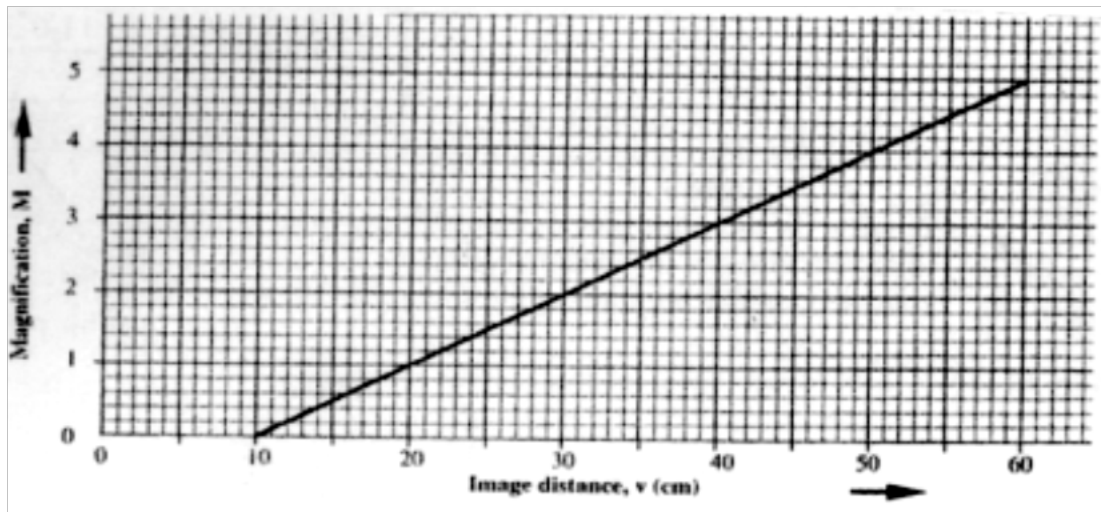

Determine:

- i) The object position when the image position is 45cm
- ii) The focal length of the mirror.

- 2a) Two identical spherical steel balls are released from the top of two tall jars containing liquids  $L_1$  and  $L_2$  respectively. Fig 3 shows the velocity – time graph of the motion of the balls.

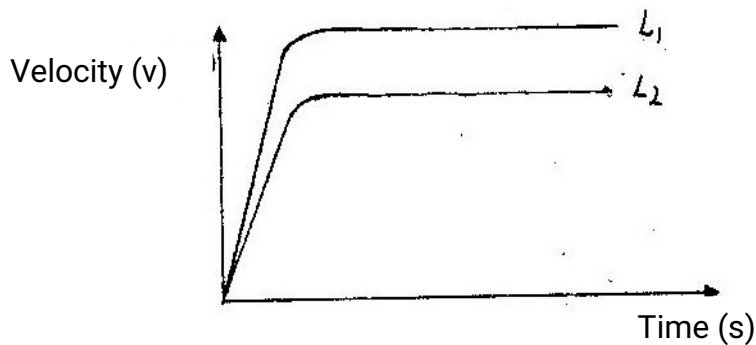
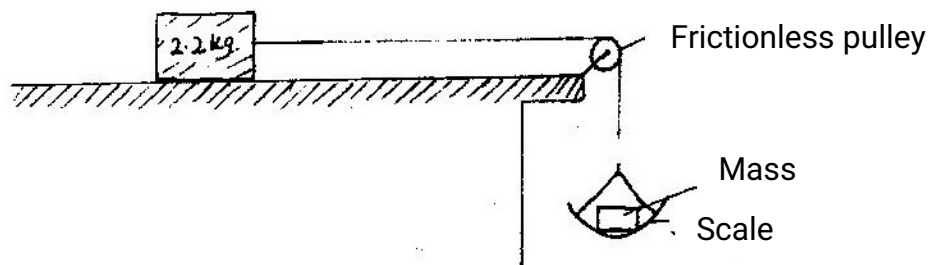

Fig 3

Explain the nature of the curves and state why they are different.

- b) In an experiment to determine the proportionality constant,  $\mu$  between two wooden surfaces sliding on each other, a block of mass 2.20kg was placed on a horizontal bench. The block was then made to slide by adding mass 'M' on the scale as shown in Fig 4. The experiment was repeated for other values of 'm'. The acceleration of the block was measured for each mass added.



The results are shown in table 1.

Table 1

Mass, m (kg)	0.70	1.00	1.50	2.00	2.50
Acceleration, a, (m/s <sup>2</sup> )	0.38	1.74	4.02	6.29	8.56

- Name and indicate on figure 4 the forces acting on the 2.20kg mass.
- Plot the graph of acceleration, a against the mass m

- iii) Given that  $a = \frac{mg}{2.20} - \mu g$ , where  $g = 10 \text{ms}^{-2}$ , use the graph to  
 Determine  $\mu$ . Intercept =  $\mu g$   
 Intercept =  $2.80 \pm 0.2$  (from graph)  
 $M = \frac{2.80 \pm 0.2}{10}$   
 $M = 0.28 \pm 0.02$

3.a) Using the kinetic theory of gases, explain how a rise in the temperature of a gas causes a rise in the pressure of the gas if the volume is kept constant.

b) Fig. 5 shows a set up that may be used to verify Charles Law.  
**Figure 5.**

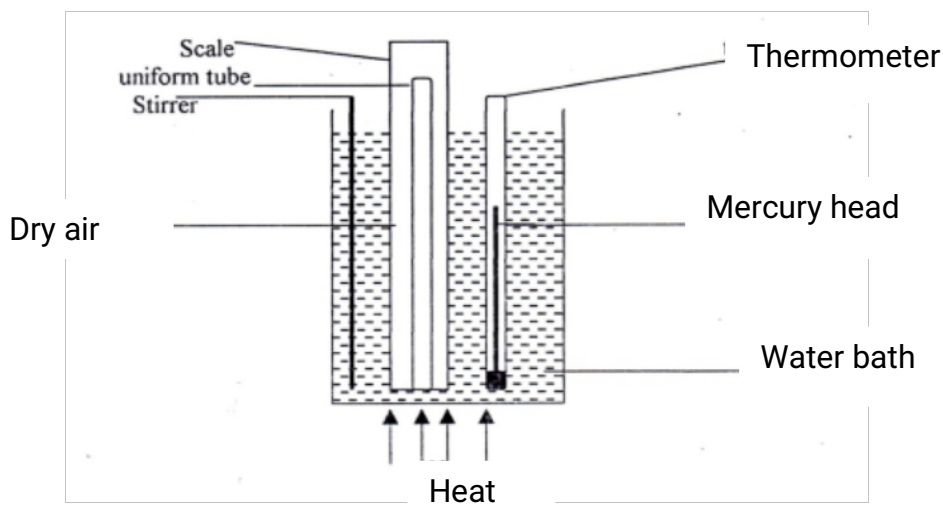

- i) State the measurements that should be taken in the experiment.
- ii) Explain how the measurements taken in (i) above, may be used to verify Charles Law.
- iii) What is the purpose of the water bath.
- c) A certain mass of hydrogen gas occupies a volume of  $1.6 \text{m}^3$  at a pressure of  $1.5 \times 10^5 \text{pa}$  and temperature  $12^\circ\text{C}$ . Determine its volume when the temperature is  $0^\circ\text{C}$  at a pressure of  $1.0 \times 10^5 \text{pa}$ .
4. (a) (i) State one property of soft iron that makes it suitable for use as a transformer core.
- (ii) Fig 6 represents a step- down transformer with 500 turns in the primary and 50 turns in the secondary. The turns are wound uniformly on the core. The lengths of PQ and QR are indicated. Determine the p.d across PQ.

(b) Fig 7 represents a block of uniform cross sectional area of  $6.0\text{cm}^2$  floating on two liquids A and B. The lengths of the block in each liquid are shown.

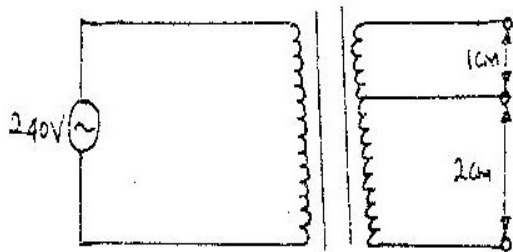

Fig. 6

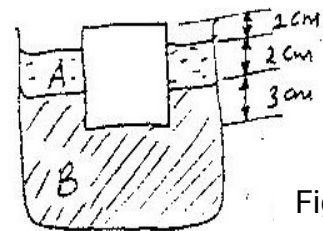
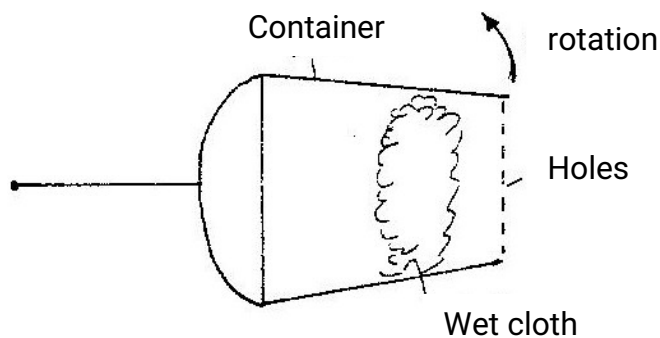

Fig 7

Given that the density of liquid A is  $800\text{kgm}^{-3}$  and that of liquid B is  $1000\text{kgm}^{-3}$  determine the:

- (i) weight of liquid A displaced
- (ii) Weight of liquid B displaced
- (iii) Density of the block

5. (a) Fig 8 shows a container with small holes at the bottom in which wet clothes have been put. When the container is whirled in air at high speed as shown, it is observed that the clothes dry faster.



Explain how the rotation of the container causes the clothes to dry faster.

- (b) (i) A glass block of mass 100g is placed in turn at various distances from the centre of a table which is rotating at constant angular velocity. It is found that a distance of 8.0 cm from the centre, the block just starts to slide off the table. If the force of the friction between the block and the table is 0.4 N determine.

- (I) The angular velocity of the table

(II) The force required to hold the block at a distance of 12 cm from the centre of the table.

(ii) A glass of mass 200 g is now placed at a distance of 8.0 cm from the centre of the table in (i) above, and the table rotated at the same constant angular velocity. State with a reason whether or not the block will slide.

## SECTION II

6a) State the necessary conditions for interference to occur in waves

b) Fig 9. Drawn to scale of 1: 200 shows two speakers  $L_1$  and  $L_2$  connected to a signal generator (not shown) producing sound waves of frequency 350Hz. An observer walking along PQ hears loud and low sounds at alternative positions.

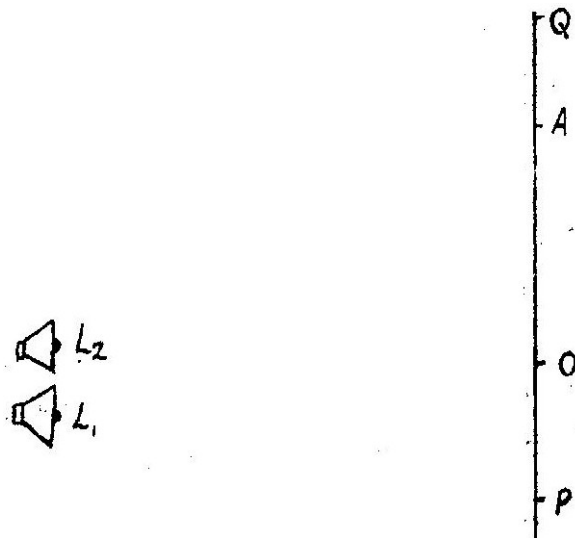

(i) Explain how the observations made are caused

(ii) At point O a loud sound is heard and at point A, the next loud sound is heard. Use this information and the diagram to determine the velocity of sound in air.

(iii) State and explain the effect of increasing the frequency of the signal generator on the distance OA.

7. (a) Explain how a p-type semiconductor is made from a pure a Semiconductor

- (b) The curves in fig 10. Show the output characteristics of a n – p-n transistor in common emitter mode. The p.d of the battery,  $V_{cc}$  is 9.0V and the load resistors  $R_L$  is  $1.8\text{ k}\Omega$

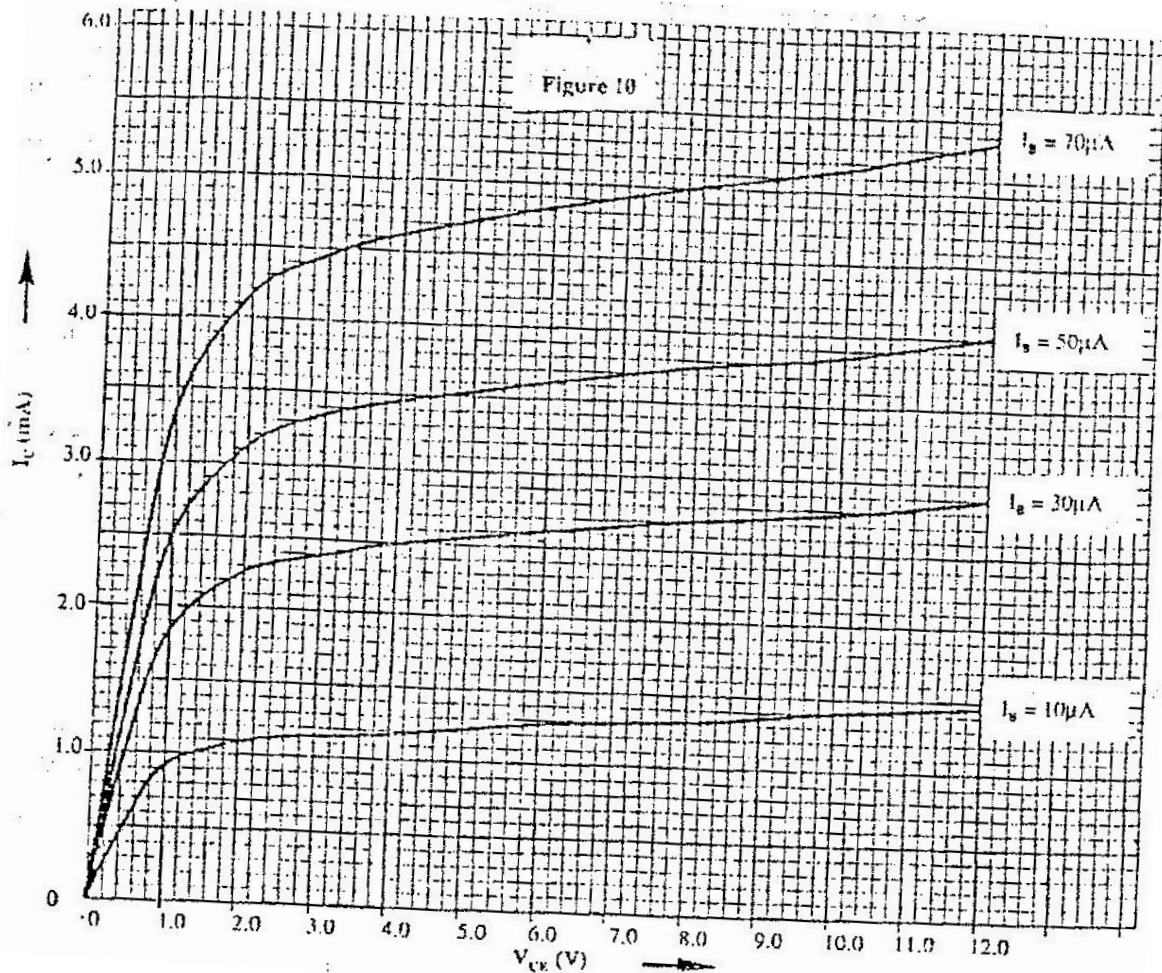

- Draw the circuit diagram for the experiment set-up that may be used to obtain the curves in the figure.
- Given that ohm's law for the circuit is  $V_{CE} = V_{cc} - I_c R_L$ , draw on the same axes, the load line for the circuit ( hint: load - line passes through. ( $V_{CE} = 0$  and  $I_c = 0$  )  
Drawing load line on graph (see graph)

When  $I_B = 30\mu A$ , An alternating signal is fed into the base so that the base current changes by  $\pm 20\mu A$ . Use the graph to determine the corresponding change in collector current  $I_c$  and hence determine the current gain  $\beta$ .



**K.C.S.E 2001**  
**PHYSICS PAPER 232/2**  
**QUESTIONS**

1. A block of ice of mass 40g at 0°C is placed in a calorimeter containing 400g of water at 20°C. Ignoring the heat absorbed by the calorimeter, determine the final temperature of the mixture after all the ices has melted. (Specific latent heat capacity of fusion of ice= 340,00J/kg, specific heat capacity of water = 4,200j/kg).
2. a) Fig 1 (a) shows the circuit of a simple telephone receiver. When the telephone is lifted, a steady current flows through the solenoids. When a person speaks into the microphone on the other side, a varying current flows. These two currents are shown in fig. 1(b).

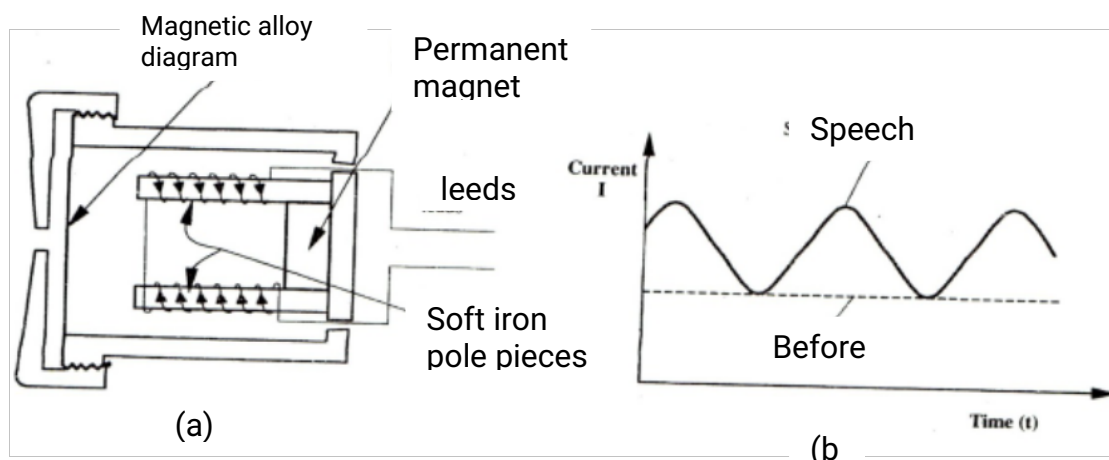

- i) State the reason why solenoids are wound in opposite directions around the soft-iron core pieces as shown.
  - ii) Explain how the speech current from the microphone is converted into sound in the receiver.
  - iii) State and explain the effect of replacing the soft iron core pieces with steel core pieces.
- b) A step down transformer has 400 turns in the primary coil and 20 turns in the secondary coil. A 50Ω resistor is connected to the secondary output. If the r.m.s (root-mean-square) value of the primary voltage is 240; determine the peak value of the current in the secondary circuit.
  - c) a hole of area 2.0 cm<sup>2</sup> at the bottom of a tank 2.0m deep is closed with a cork. Determine the force on the cork when the tank is filled with water. (Density of water is 1000kg/m<sup>3</sup> and acceleration due to gravity is 10m/s<sup>2</sup>).



4. Fig 3 shows the main features of a cathode ray tube (CRT) of a cathode ray oscilloscope (CRO)

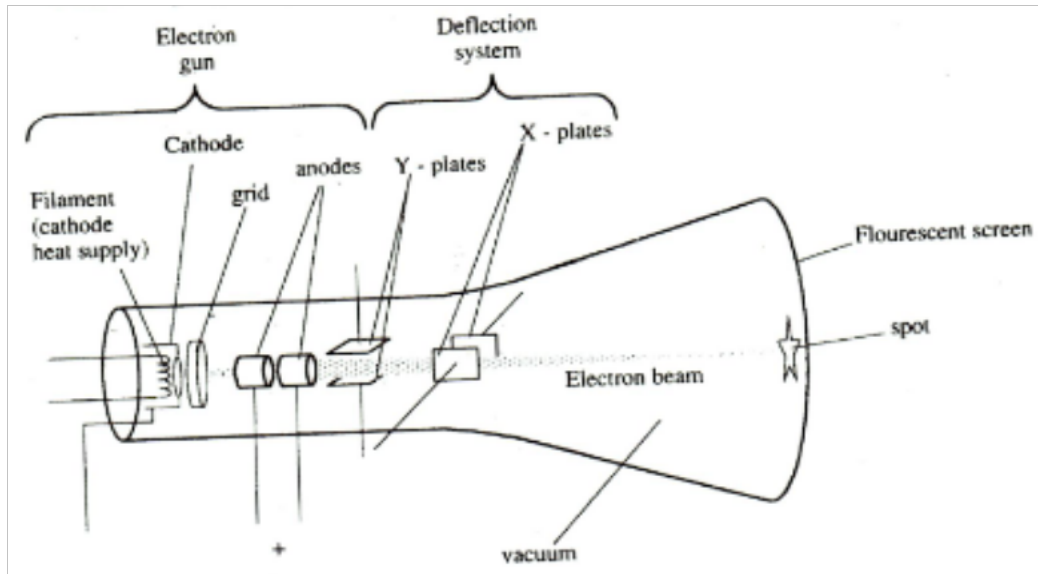

- i) Describe how the electrons are produced in the tube.
  - ii) State and explain the function of the grid.
  - iii) State what would be observed on the screen if an a.c voltage is connected across the y-plates.
  - iv) State how the deflection system of a television differs fro that of a CRO.
  - v) Give the reason why it is possible to have a wider screen in the television set than on the C.R.O.
- b) In an excited hydrogen atom. An electron moves from an energy level of  $-1.36 \times 10^{-19} \text{J}$ . Determine the wavelength of the radiation emitted. (Planks constant  $h= 6.63 \times 10^{-34} \text{ Js}$  and speed of light  $c= 3.0 \times 10^8 \text{ ms}^{-1}$ ).
- 5 a) You are provided with 12V a.c source, four diodes and resistor.
- i) Draw a circuit diagram for a full wave rectifier and show the points at which the output is taken.

AC source shown-symbols; arrangement of diode (one for each pair); correct position of R; correct position of output.

- ii) Sketch the graph of the output when a capacitor is put in parallel with the resistor in the circuit in (i) above.



- b) A certain transistor is connected in common-emitter-mode. The base current  $I_B$  is 0.50 mA. Determine the values of the:

- (i) Emitter current  $I_E$ .  
 (ii) Base-collector current gain  $\beta$   
 (iii) Current gain  $\alpha$

## SECTION II

- 6 a i) State one of the Newton's law of motion  
 ii) A body resting on a horizontal surface is given an initial velocity  $V$  so that it slides on the surface for some distance before coming to a stop. Table I shows the distances  $d$  moved by the body of various values of  $\mu$ .

Velocity ( $\text{ms}^{-1}$ ) $\mu$	0.20	0.40	0.60	0.80	1.20	1.20
Distance, $d$ (m)	0.007	0.027	0.027	0.110	0.170	0.200

Given that  $v^2$  is  $20\mu d$  where  $\mu$  is a constant for the surface, plot a appropriate graph and use it to determine  $\mu$ . Determine values of  $\mu$  on table.

- b) A train of mass 200 tonnes starts from rest and accelerates uniformly at  $0.5\text{ms}^{-2}$  determine its momentum after moving 100m.

- 7 ai) State the pressure law of an ideal gas.

- ii) The pressure  $p$ , of a fixed mass of a gas at constant temperature  $T = 300\text{K}$  is varied continuously. The corresponding values of  $P$  and the volume  $V$  of the gas are shown in table 2.

Pressure, $p$ ( $\times 10^5\text{Pa}$ )	2.00	2.50	3.00	3.50	4.00	4.50
Volume, $V$ ( $\text{m}^3$ )	0.025	0.020	0.017	0.014	0.012	0.011

Given that  $PV = 2RT$  where  $R$  is a constant, plot an appropriate graph and use it to determine  $r$ .

$1/V$ ( $\text{M}^{-3}$ )	40.0	5	58.8	71.4	83.3	90.0
---------------------------	------	---	------	------	------	------

- b) A tin closed with an airtight lid contains air at a pressure of  $1.0 \times 10^5\text{ Pa}$  and temperature of  $12^\circ\text{C}$ . The tin is heated in a water bath until the lid opens. If the temperature at which the lid opens is  $88^\circ\text{C}$ , determine the pressure attained by the gas. (Ignore expansion of the tin).

$1/P \times 10^5$ ( $\text{pa}^{-1}$ )	0.5	0.40	0.33	0.29	0.25	0.22
--	-----	------	------	------	------	------

**K.C.S.E 2002**  
**PHYSICS PAPER 232/2**  
**QUESTIONS**

1. Figure 1 shows the path of array of yellow light through a glass prism. The speed of yellow light in the prisms is  $1.88 \times 10^8 \text{ m/s}$ .

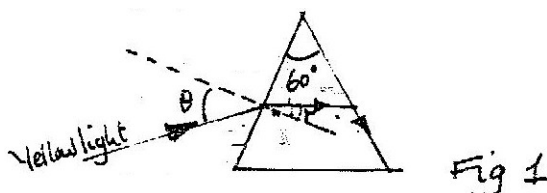

- a) Determine the refractive index of the prism material for the light (speed of light in vacuum  $c = 3.0 \times 10^8 \text{ ms}^{-1}$ )
  - b) Show on the figure the critical angle,  $c$ , and determine its value.
  - c) Given that  $r = 21.2^\circ$ , determine the angle  $\theta$
  - d) On the same figure, sketch the path of the light after striking the prism if the prism was replaced by another of similar shape but lower refractive index. (Use dotted line for your answer)
2. Fig. 3. Shows the path of radiation from a radioactive source after entering a magnetic field. The magnetic field is directed into the paper and is perpendicular to the plane of the paper as shown in the figure.

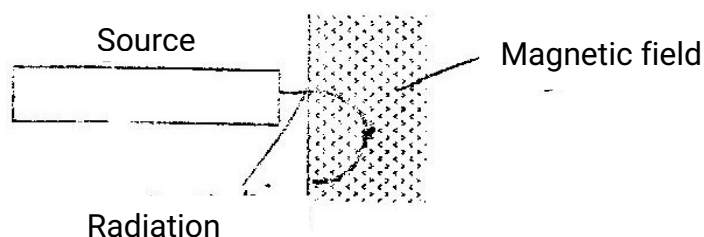

Identify the radiation

- b) Below is a nuclear reaction



- i) Identify radiation K
- ii) Determine the values of X and Y.

- (c) Fig 3 shows a device for producing metal foils of constant thickness. Any change in thickness can be detected by the Geiger tube and recorded by the Geiger. The pressure adjusted by the roller is then adjusted to keep the thickness constant.

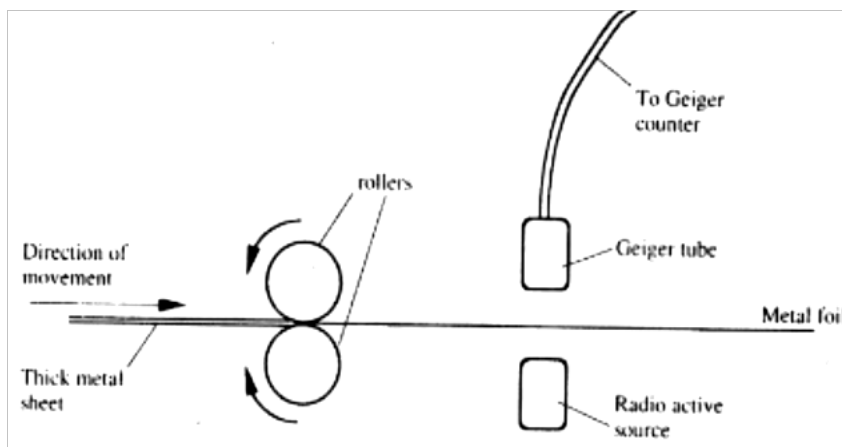

- (i) State the change in the metal foil that will lead to a decrease in the Geiger counter reading
  - (ii) Give a reason for your answer in c(i) above
  - (iii) State the change in the roller pressure that should be made as a result of this decrease in the Geiger counter reading.
  - (iv) Give a reason for your in (c) (iii) above
  - (v) Explain why a source emitting  $\alpha$  (alpha) particles only would not be suitable for this device.
  - (vi) Explain why a radioactive source of a half-life of 1600 years is more suitable for use in the device than one of a half-life of 8 minutes.
3. Fig. 4 shows a block of a mass 30.0 kg being pulled up a slope by a force P at a constant speed. The friction force on the block is 20.0N.

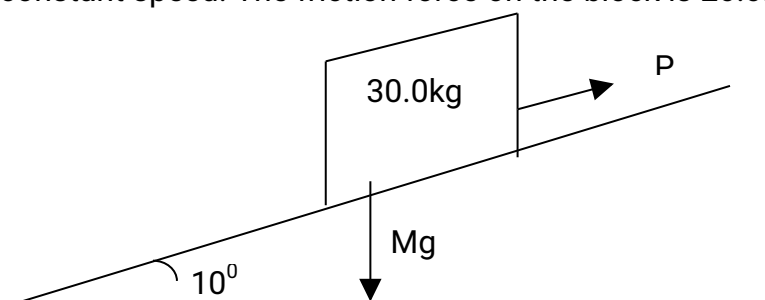

Fig. 4

- a i) On the same figure name and indicate the other forces acting on the block.
  - ii) Determine the component of the weight acting on the trolley down the slope
  - iii) Determine the value of P.
- b) On reaching the top of the slope, the block is left to run freely down the

slope.

- i) Which one of the forces previously acting on the block would then act in the opposite?
- ii) Determine the acceleration of the block down the slope.
- iii) What is the effect of increasing the angle of slope on your answer in (ii) above.

4. a) Fig 5. Shows the variation of temperature,  $T$  ( $^{\circ}\text{C}$ ), with time,  $t$  (seconds). When frozen water is heated for sometime.

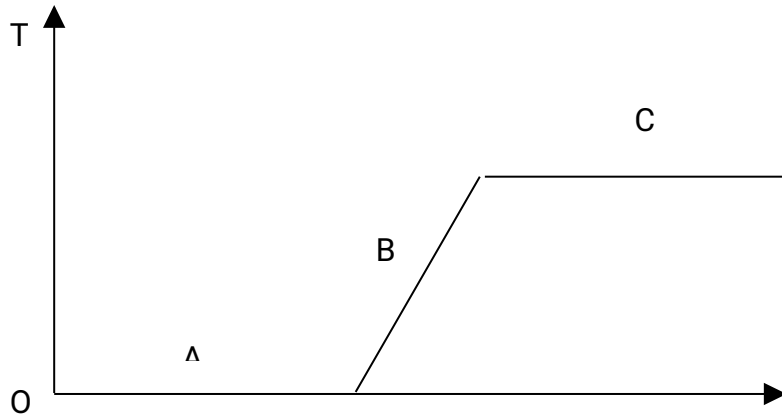
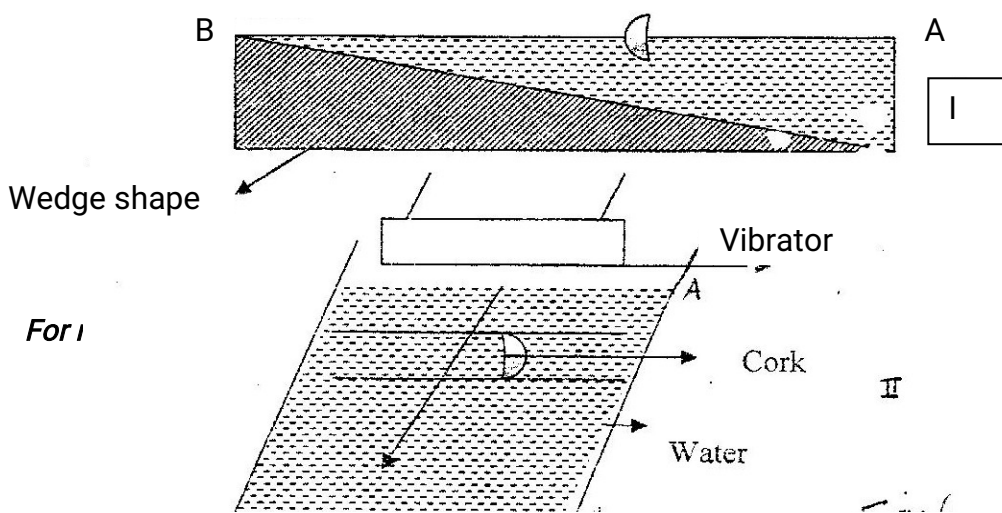

Fig. 5

- (i) Explain the shape of the curve at the parts labeled AB and C.
  - (ii) It is observed that when the temperature starts to rise, the volume initially decreases and then increases. State the reason for this observation.
  - (iii) In the fig. 5 sketch and explain the curve that would be obtained if frozen water was used. (Hint: specific heat capacity for seawater is lower than that of fresh water.)
- (b) Determine the quantity of heat energy required to change 3.0 kg of ice at  $0^{\circ}\text{C}$  to water at  $5^{\circ}\text{C}$ . Specific latent heat of fusion of ice is  $3.36 \times 10^5 \text{ J/kg}$ . Specific heat capacity of water is  $4200 \text{ J/kgK}$

5 a) Fig 6.1 shows the cross-section of a ripple tank full of water. A piece of cork floats on the surface of the water as shown. Fig 6 II shows the water surface viewed from above. A straight edge vibrator placed at the end A of ripple tank generates water waves, which travel towards end B as shown.





Cork

Water

Fig 6

- (i) Identify the type of waves generated on the water surface.
- (ii) It is observed that as the waves pass the cork, there is no net movement on the cork. Explain this observation
- (iii) A student estimates that successive waves pass the cork every 0.20 seconds. If the speed of the waves is  $0.30 \text{ ms}^{-1}$ , determine the frequency and wavelength of the waves at that point.
- iv) In the space provided, sketch the wave fronts as viewed from a point above the ripple tank.

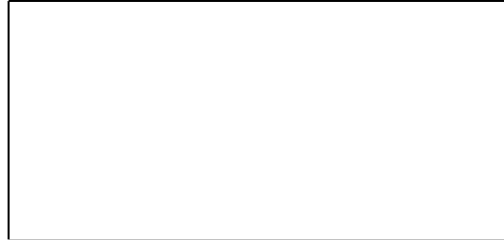

- v) Explain the answer in part (iv) above
  - b) A tuning fork is sounded at the mouth of a pipe whose one end is closed with a moveable piston. Resonance is observed successively when the piston is 77cm and then at 129 cm. If the speed of sound in air is  $340 \text{ ms}^{-1}$ , determine the frequency of the tuning fork.
6. a) State the law that relates the volume of a gas to the temperature of a gas.
- b) Fig 7. shows an experiment set-up that may be used to investigate one of the laws. The glass tube has a uniform bore and it is graduated in millimeters
- Clam

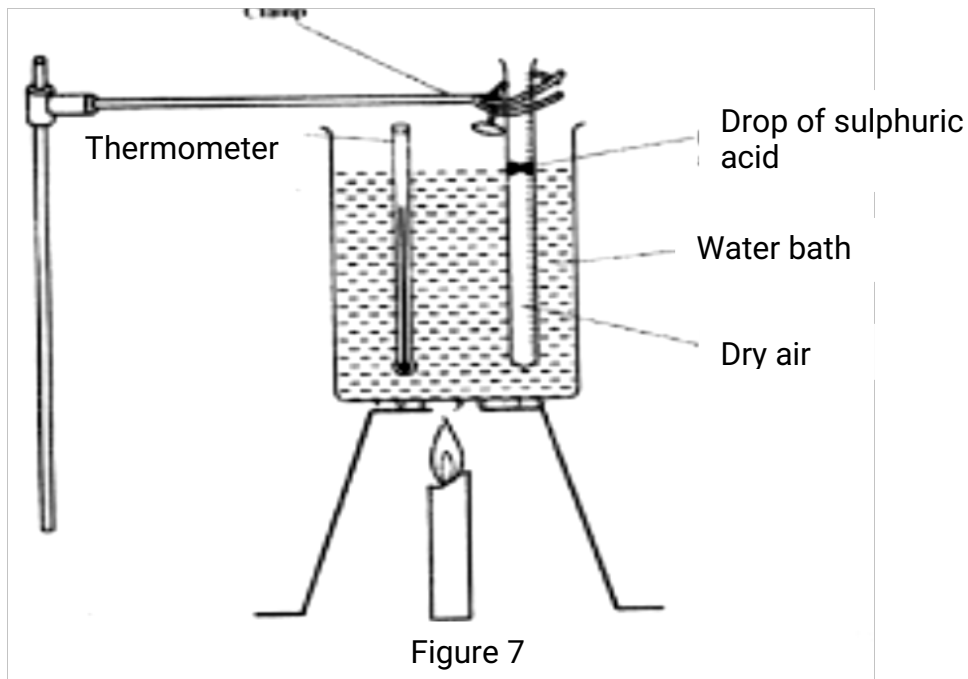

- i) Describe how the experiment was carried out and explain how the results obtained verify the law.
- ii) Limitations of the set up are?
- c) In an experiment to find the relation between pressure,  $p$ , and temperature,  $\theta$ , of a gas at a constant volume, values of temperature were determined. The results obtained are shown in the graph below.

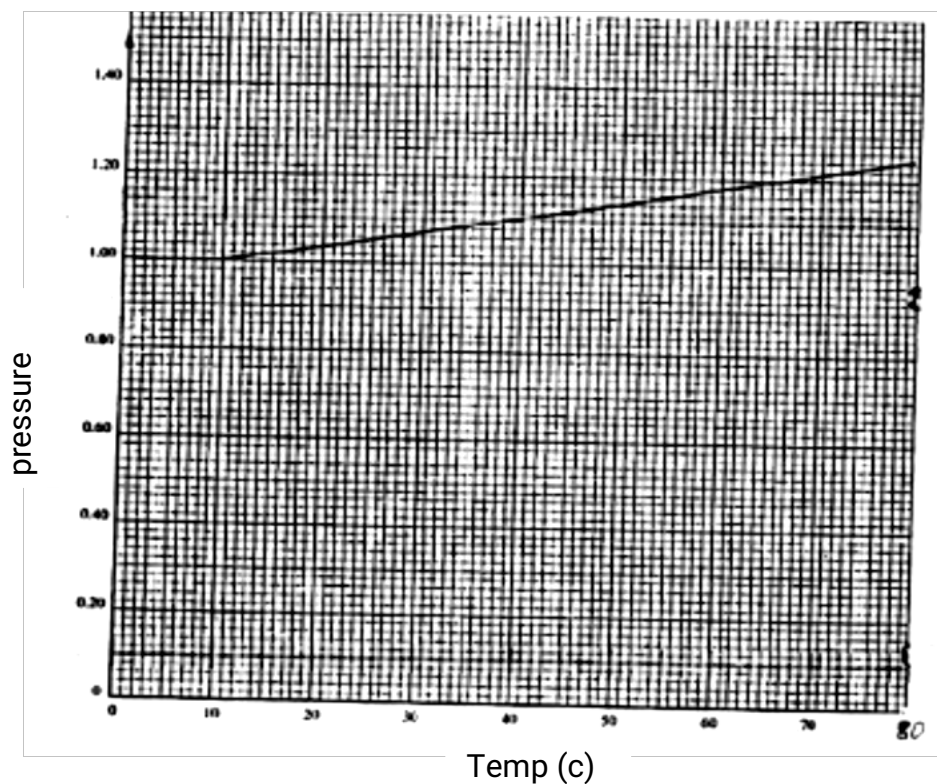

- (i) From the graph, determine the pressure at a temperature of 273K.
- (ii) Assuming the relation  $p/T_0 + \theta = \text{constant}$  holds for this graph determine the value of the constant  $T_0$

7a) Fig. 8 shows ultra violet light striking a polished zinc plate placed on a negatively charged gold – leaf electroscope.

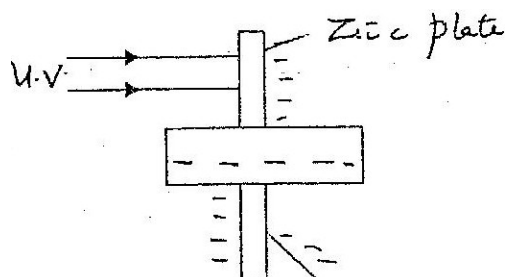

Explain the following observations

- i) The leaf of the electroscope falls.
- ii) When the same experiment was repeated with a positively charged electroscope the leaf did not fall.

B i) State two factors which determine the speed of photoelectrons emitted by a metal surface

- ii) In an experiment using a photocell, u, v. light of varying frequency but constant intensity was made to strike a metal surface. The maximum kinetic energy ( $KE_{\text{max}}$ ) of photoelectrons for each frequency, was measured. The graph shows how  $KE_{\text{max}}$  varies with  $f$ .

Given that  $KE_{\text{max}} = hf - \Phi$ , determine the value of the constants  $h$  and  $\phi$  from the graph.

- c) Light of frequency  $5.5 \times 10^{14}$  Hz is made to strike a surface whose work function is 2.5eV.  
Show that photoelectric effect will not take place.(Use the value of  $h$  from (b) above.

**K.C.S.E 2003**  
**PHYSICS PAPER 232/2**  
**QUESTIONS**

1a. Fig 1 shows the displacement time graph of the motion of a particle.

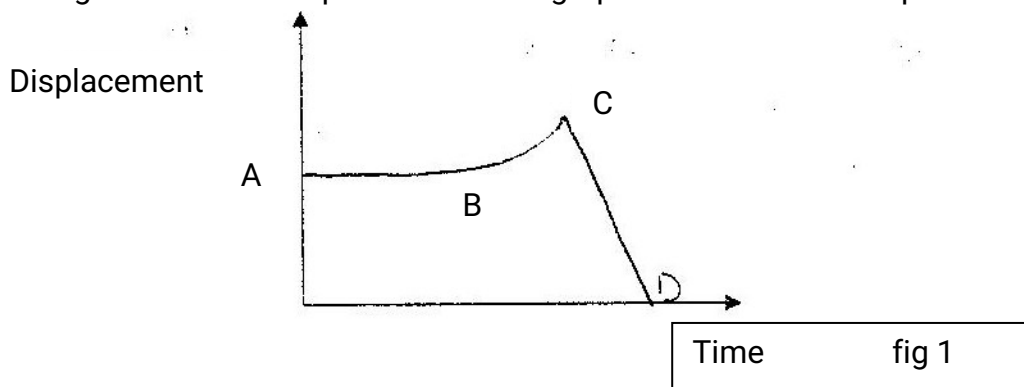

State the nature of the motion of the particle between:

- (i) A and B      (ii) B and c      (iii) C and D

b) A ball is thrown horizontally from the top of a vertical tower and strikes the ground at point 50m from the bottom of the tower. Given that the height of the tower is 45m, determine the :

- i) Time taken by the ball to hit the ground.
  - ii) The initial horizontal velocity of the ball
  - iii) Vertical velocity of the ball just before striking the ground. (Take acceleration due to gravity  $g$  as  $10\text{ms}^{-2}$ )
- Total 13 marks

2. a) A crane lifts a load of 200kg through a vertical distance of 3.0m in 6 seconds. Determine:

- (i) Work done
- (ii) Power development by the crane.
- (iii) Efficiency of the crane given that it is operated by an electric motor rated 12.5kW.

(b) A child of mass 20kg sits on a swing of length 4m and swings through a vertical height of 0.9m as shown in figure 2..

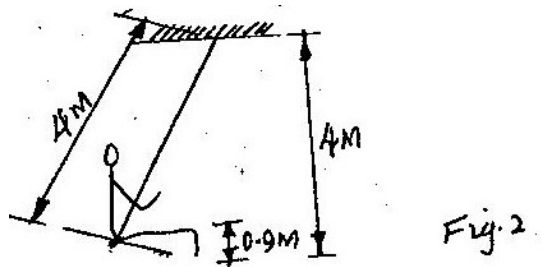

Determine:

- (i) Speed of the child when passing through the lowest point.
- (ii) Force exerted on the child by the seat of swing when passing through the lowest point.

(14mks)

3a) State what is meant by the term 'specific latent heat of vaporization'

b) In an experiment to determine the specific latent heat of vaporization of water, steam at  $100^{\circ}\text{C}$  was passed into water contained in a well-lagged copper calorimeter. The following measurements were made;

(i) Determine the:

- I Mass of condensed steam
- II Heat gained by water  
Heat gained by calorimeter

(ii) Given that  $L$  is the specific latent heat of vaporization of steam,

- I write an expression for the heat given out steam.
- II Determine the value of  $L$ .

4 a) Figure 3 shows a transverse wave traveling along x-axis.

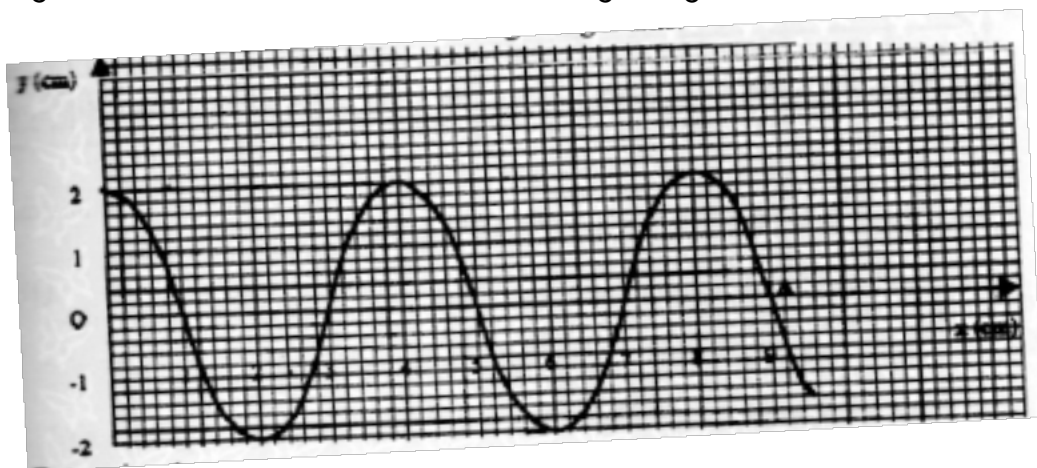

(i) Determine the:

- I Wavelength of the wave
- II Amplitude of the wave.

(ii) If the time taken by the wave to move from 0 to A is 0.09 seconds, determine the:

- I Frequency of the wave.
- II Speed of the wave

b) Figure 4 shows a Geiger muller (GM) tube

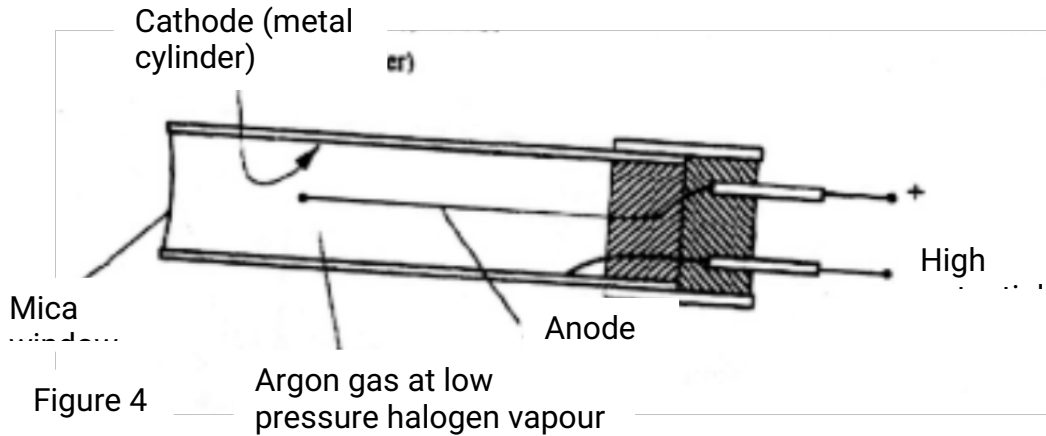

- (i) Give the reason why the mica window is made thin.
- (ii) Explain how the radiation entering the tube through the window is detected by the tube.
- (iii) What is the purpose of the halogen vapour

- 5
- a) States what is meant by electromotive force (em.f) of battery.
  - b) The graph in figure 5 shows the terminal voltage,  $V$ , of a certain battery varies with the current,  $I$ , being drawn from the battery.

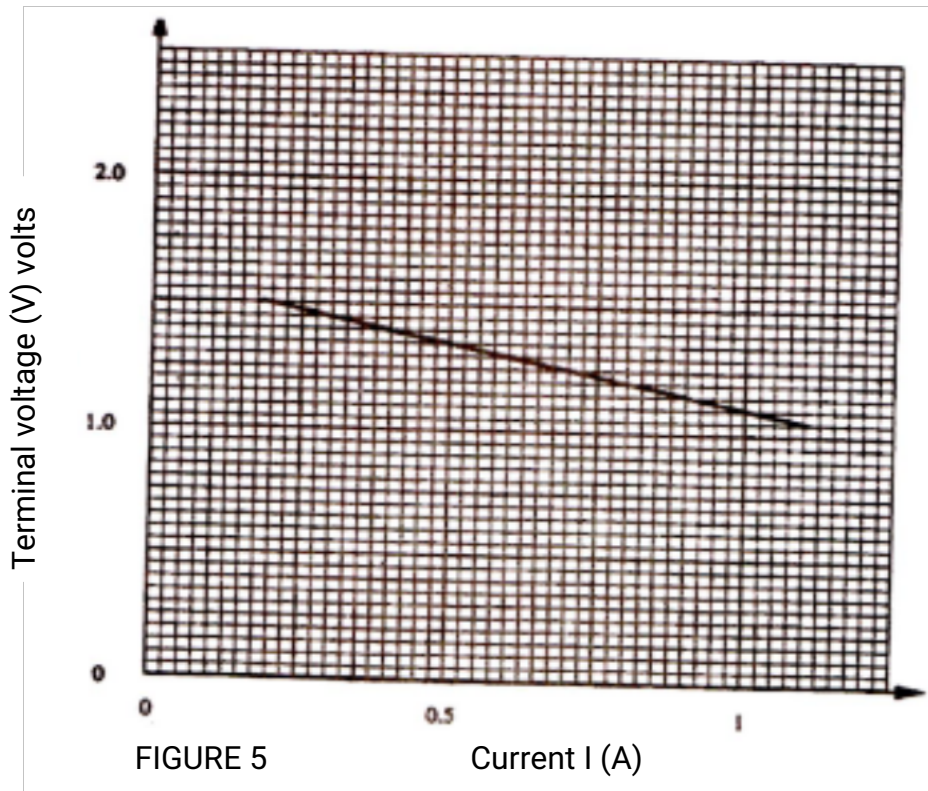

- (i) Write an expression relating the e.m.f.  $E$ , terminal voltage,  $V$ , current,  $I$  and the internal resistance,  $r$ , of the battery for the circuit drawn in (i) above.
- (iii) From the graph determine the; I internal resistance,  $r$ , of the battery.
- (C) A galvanometer of resistance  $10\Omega$  gives a full-scale deflection when a current of  $0.03\text{A}$  flows through it. Determine the resistance of the resistor, which would be required to convert the galvanometer to an ammeter reading up to  $3.0\text{a}$ .

## SECTION II

- 6 a) Figure 6 shows a simple set up for pressure law apparatus.

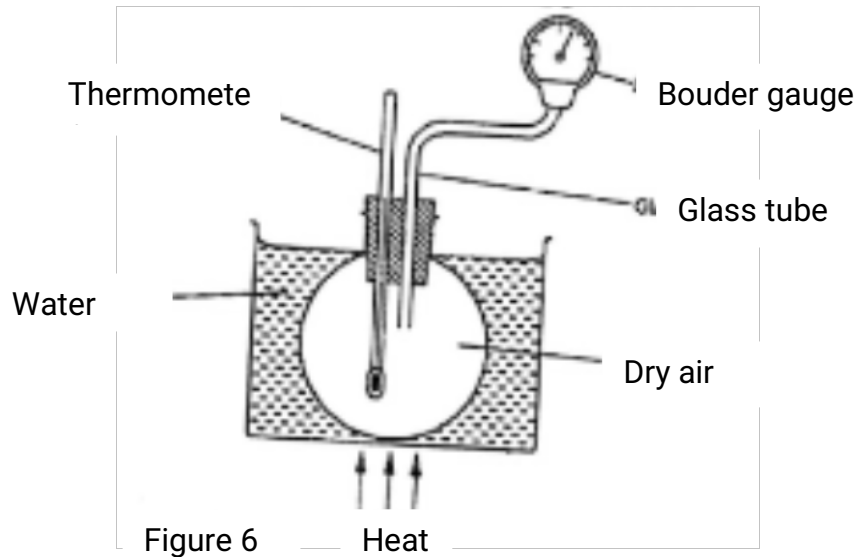

Describe how the apparatus may be used to verify pressure law. Initial reading of pressure and temperatures are recorded.

- b) The graph in fig 7 shows the relationship between the pressure and temperature for a fixed mass of an ideal gas at a constant volume.



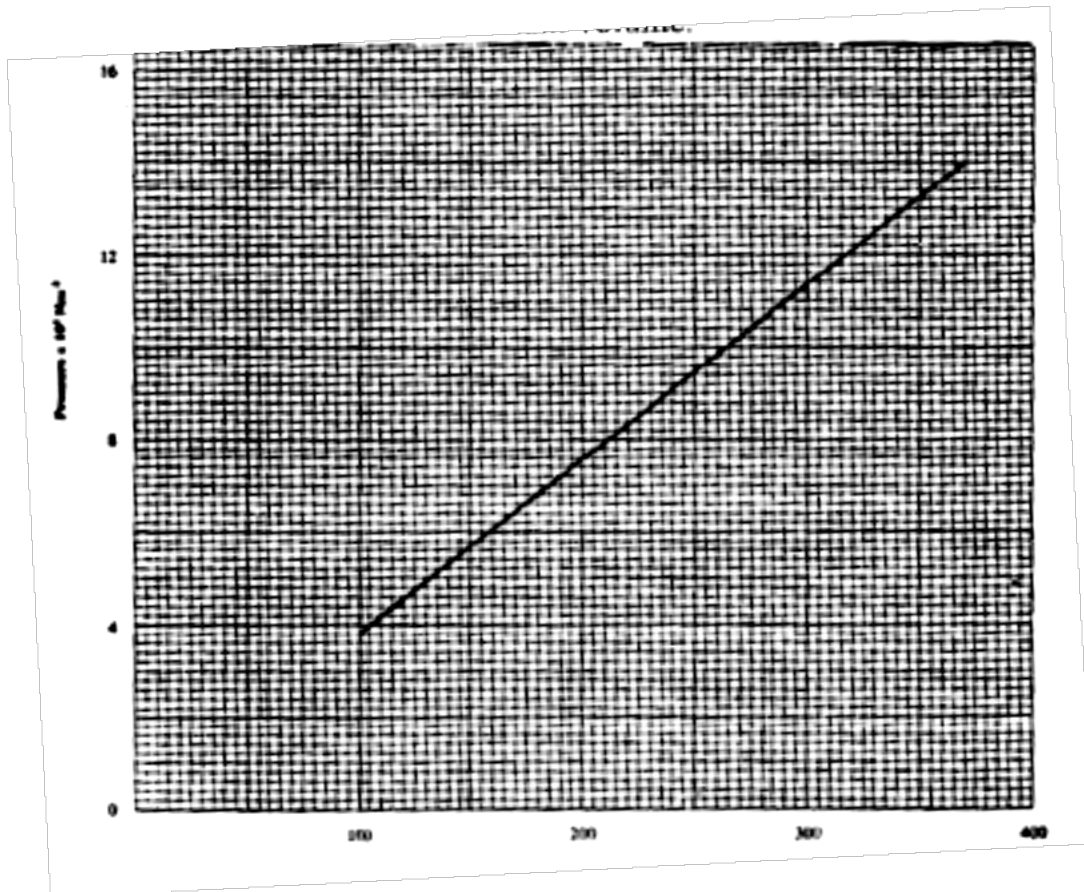

Fig. 7

- (i) Given that the relationship between pressure,  $p$ , and temperature,  $T$  Kelvin is of the form  $P = kT + C$  where  $k$  and  $C$  are constants, determine from the graph, values of  $k$  and  $c$ .
- (ii) Why would it be impossible for pressure of the gas to be reduced to zero in practice?
- (c) A gas is put into a container of fixed volume at a pressure of  $2.1 \times 10^5 \text{ Nm}^{-2}$  and temperature  $27^\circ\text{C}$ . The gas is then heated to a temperature of  $327^\circ\text{C}$ . Determine the new pressure.

7. a) Fig. 8. shows an experimental set up consisting of a mounted lens. L, a

screen, s, a meter rule and a candle.

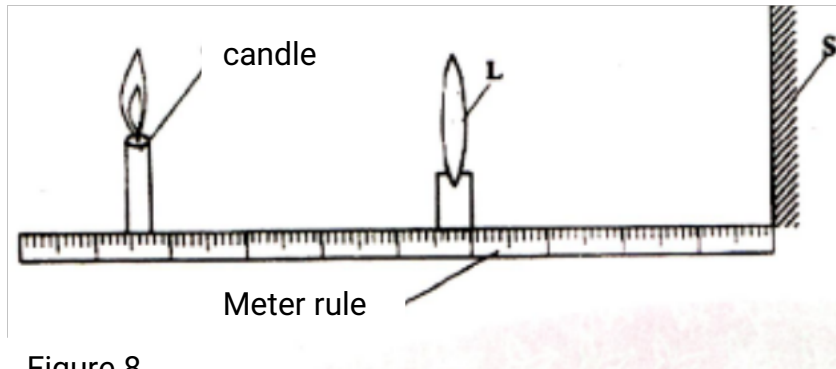

Figure 8

- (i) Describe how the set-up may be used to determine the focal length,  $f$ , of the lens.
  - (ii) State the reason why the set-up would not work if the lens were replaced with a diverging lens.
- (b) The graph in figure 9. shows the relationship between  $1/u$  and  $1/v$  for converging lens where  $u$  and  $v$  are the object and image distances respectively.

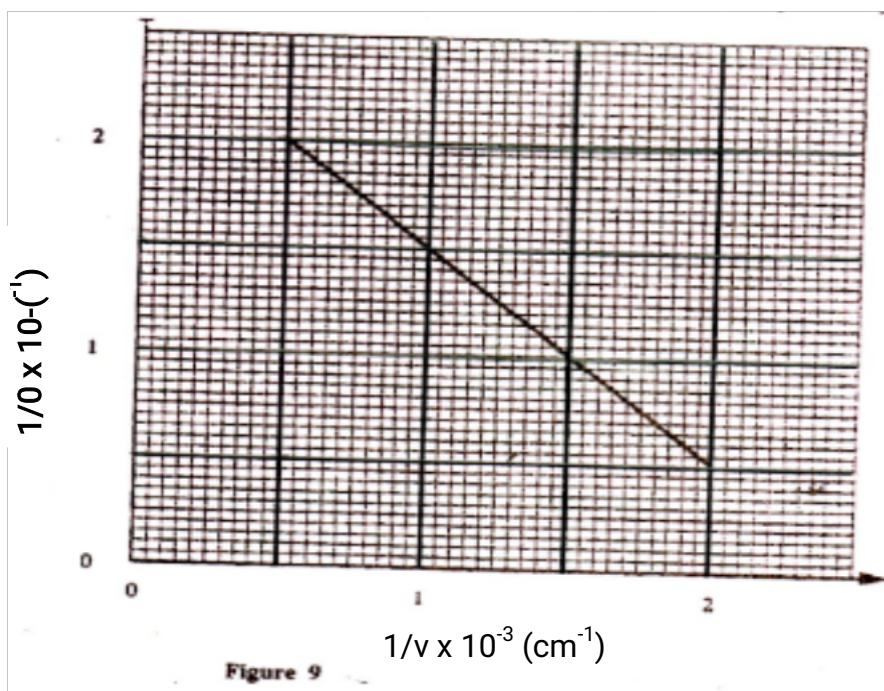

Figure 9

For the graph, determine the focal length,  $f$  of lens.

- (c) An object placed 15cm from a convex lens is magnified two times. Determine the focal length of the lens.



**K.C.S.E 2004**  
**PHYSICS PAPER 232/2**  
**QUESTIONS**

**SECTION 1 (65 MKS)**

1. a) A test tube of uniform cross-section loaded so that it can float upright in water. With the aid of a labeled diagram, describe how the test tube may be calibrated to measure the density of liquid.
- b) In an experiment to determine the density of a liquid, a uniform metal cylinder of cross-section area  $6.2\text{cm}^2$  was hang from a spring balance and lowered gradually into the liquid. The up thrust was determined for various submerged lengths. The results obtained are shown on the graph in Fig 1.

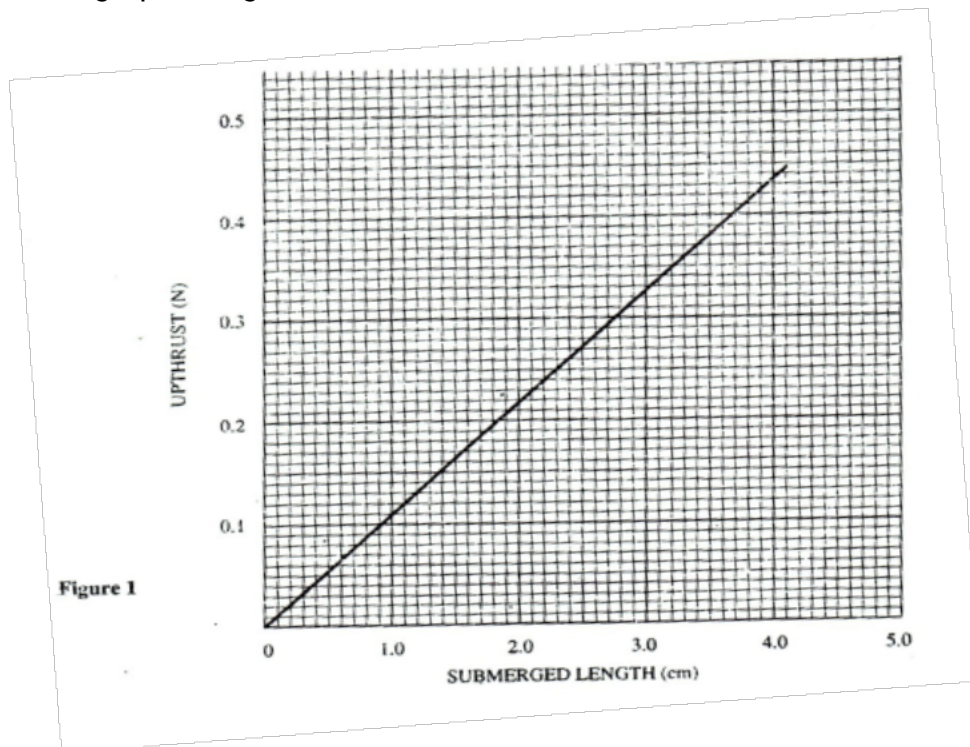

Using graph, determine;

- (i) The value of the up thrust when the cylinder is fully submerged
- (ii) The Density of the liquid

2. a) In an experiment to determine the power of an electric heater, melting ice was placed in a container with an outlet and the heater placed in the ice as shown in Fig. 2. The melted ice was collected.

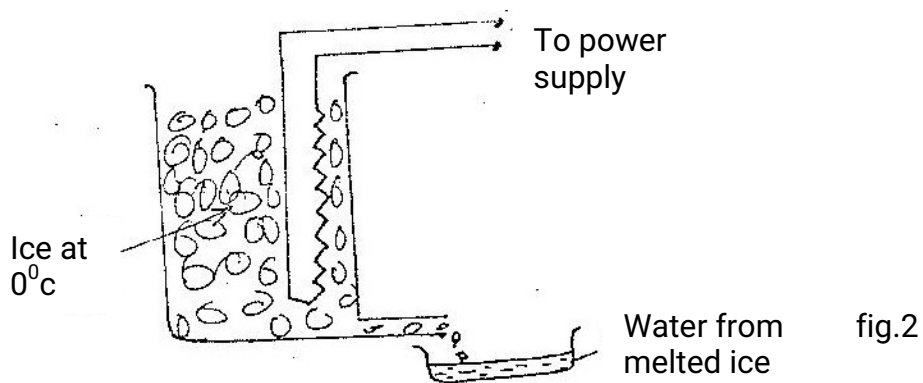

- i) Other than the current and voltage, state the measurement that would be taken to determine the quantity of heat absorbed by the melted ice in unit time.
- (ii) If the latent heat of fusion of ice is  $L$ , show how measurement in (i) above would be used in determining the power  $P$ . of the heater.
- (iii) It is found that the power determined in this experiment is lower than the manufacturer's value indicated on the heater.
- b) Fig 3 shows part of an experimental set up for estimating the diameter of an oil molecule.

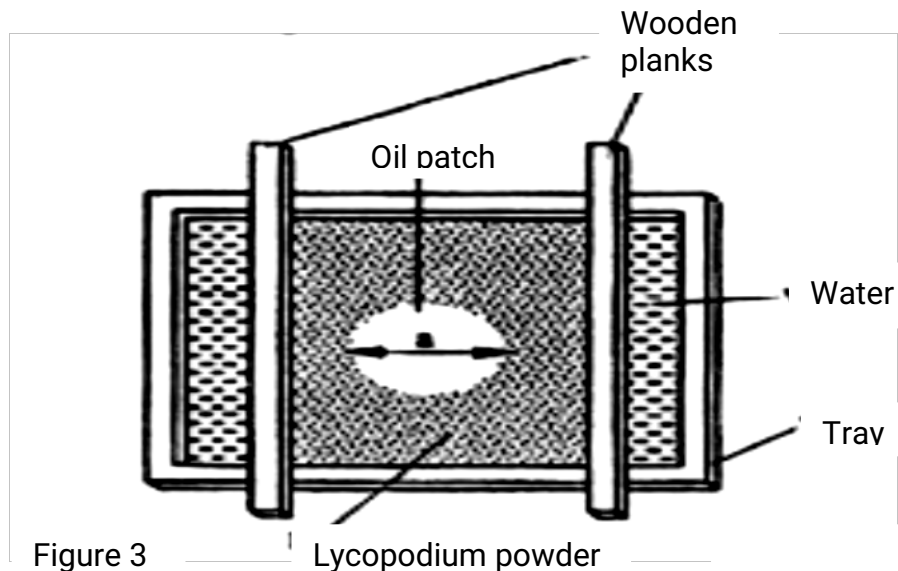

- i) Describe how the oil patch is formed

- ii) In an experiment the diameter  $a$ , of the patch was measured to be 200mm for an oil drop of radius 0.25mm. Determine the diameter of the molecule of the oil.

3. Figure 4 shows the cross-section of a diffusion cloud chamber used to detect radiation from radioactive sources.

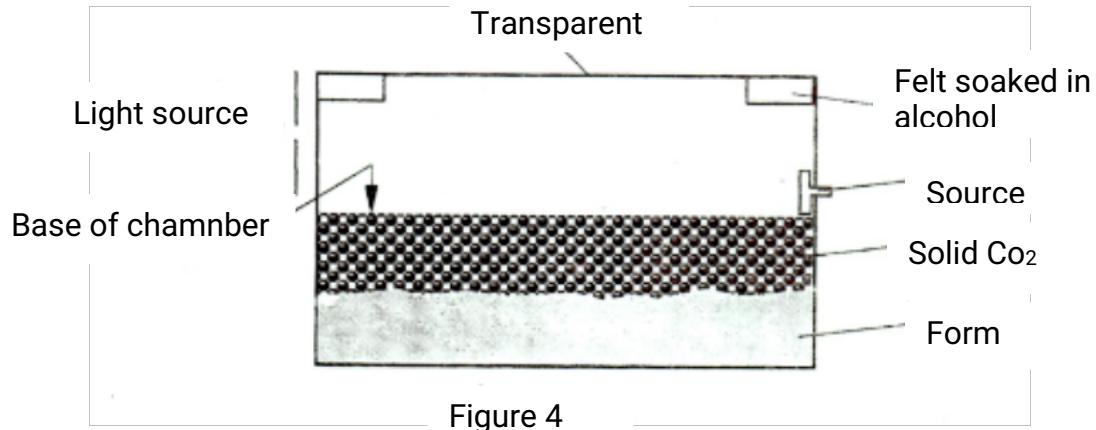

- a) i) State one function of each of the following:  
Alcohol  
solid  $\text{CO}_2$
- iii) When radiation from the source enters the chamber, some white traces are observed. Explain how these traces are formed and state how the radiation is identified.
- iii) A leaf electroscope can also be used as a detector of radiation. State two advantages of the diffusion cloud chamber over the leaf electroscope as a detector.
- b) i) Two samples of the same radioactive material have initial masses  $M$  and  $2M$  respectively. On the axes provided, sketch the graph of activity versus time for each sample. Label the graph for each sample.

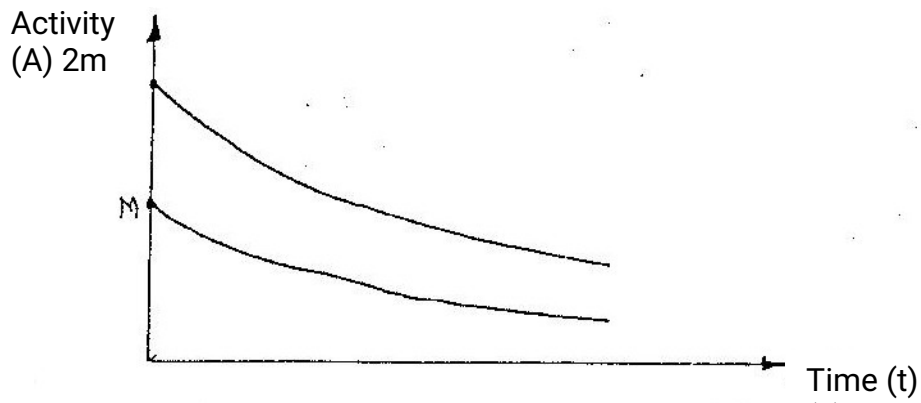

- ii) A radioactive sample of half-life 130 days initially has  $1.0 \times 10^{20}$  radioactive atoms. Determine the number of radioactive atoms that have decayed after 390 days.

4. a) Fig 5 shows the displacement time graph of a wave traveling at 200cm/s

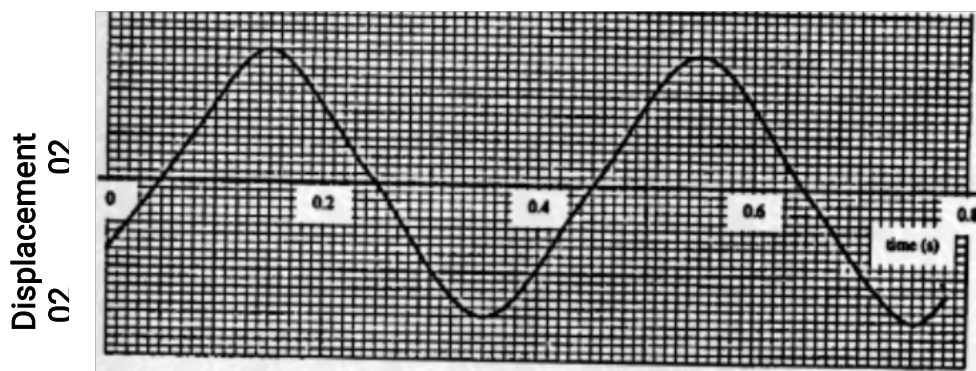

Determine for the wave the

- i) Amplitude
  - ii) Period
  - iii) Frequency
  - iv) Wavelength
- b) i) In the space provided below, sketch a labeled diagram to show how pinhole camera forms an image of a vertical object placed in front of the pinhole.
- ii) a building standing 200m from a pinhole camera produces on the screen of the camera an image 2.5cm high 5.0cm behind the pinhole. Determine the actual height of the building.

5. a) Fig 6 shows a simple generator. The coils are rotated in the anticlockwise direction as shown.

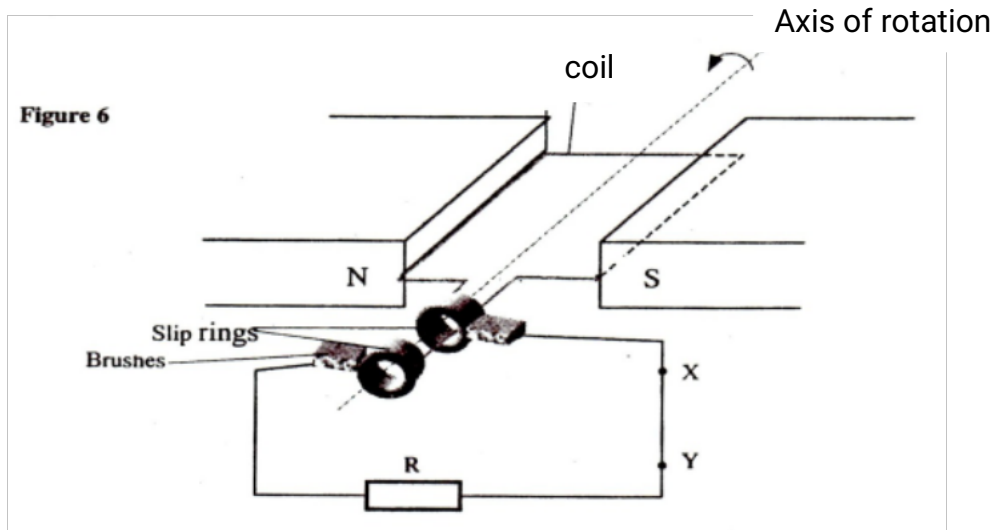

- i) Indicate using an arrow on the figure, the direction of the induced current as the coil passes the position shown.
- ii) State two ways of increasing the magnitude of the induced current in this type of generator.
- iii) On the axes provided, sketch the graph of the induced e.m.f with time.
- iv) The section marked XY is cut off and a diode inserted. On the axes provided, sketch the graph of p.d across the resistor R, against time.





- b) Fig 7 shows pendulum A and pendulum B freely suspended between the poles of identical magnets. Pendulum a is made of thick copper plate while B is made a copper plate with slots

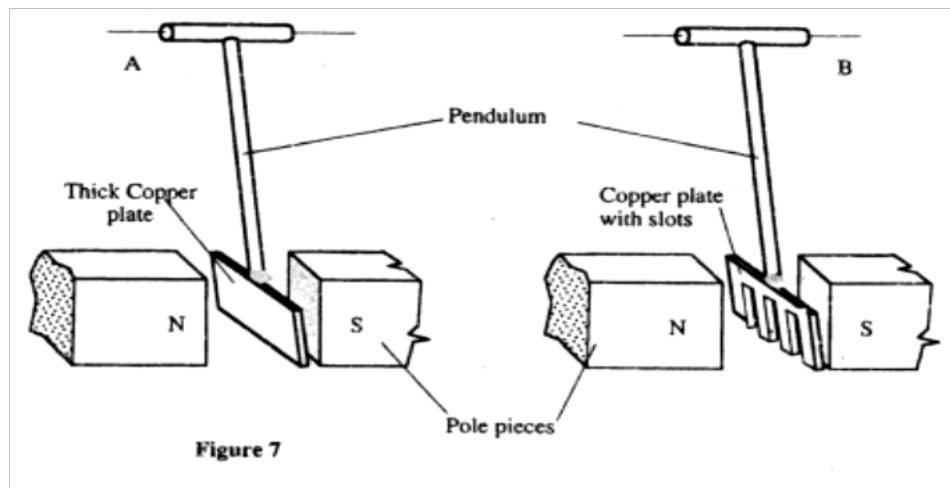

When the two are set to swing, it is observed that A slows down faster than B Explain this observation.

- c) An alternating current source has a root-mean-square potential difference of 12,V, Determine the peak value of this potential difference.

### SECTION II (15MKS)

*Answer ONE question from this section on the spaces provided*

6. a) You are provided with two identical tuning forks and some plasticine. Describe how you would demonstrate beats in sound.
- b) Fig 8 shows a set up that was used in an experiment to determine the speed of sound air

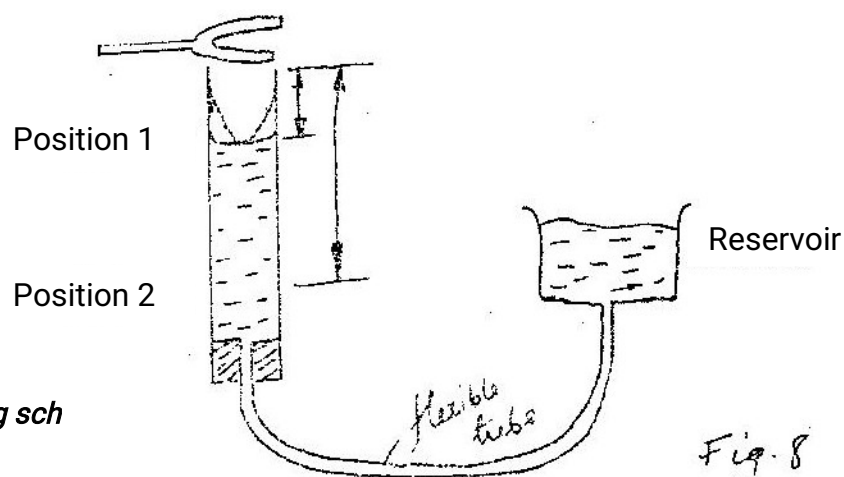

*For marking sch*

Turning forks of different frequencies were sounded near the mouth of the open tube and by lowering the reservoir, the list two resonant lengths  $L_1$   $L_2$  were ensured for each frequency.

Table 1 shows the results obtained.

Frequency, f (HZ)	256	288	341	427	480	512
$L_1$ (cm)	30,8	27.2	22.8	17.9	15.8	14.7
$L_2$ (cm)	95.5	84.5	71.2	56.6	50.2	46.9
$1/f$ (HZ <sup>-1</sup> )						
$L_2 - L_1$ (m)						

- (i) Complete the table. On the grid provided, plot the graph of  $L_2 - L_1$  (y-axis) against  $1/f$
- (ii) From the graph determine the speed  $V$  of sound in air given that  $L_2 - L_1 = v/2r$ . Therefore  $V = 2f(L_2 - L_1)$
- (iii) Explain how resonance is attained in this set up.

7. a) i) What is photoelectric effect?

ii) You are provided with the following:

a photocell, a source uv light, a rheostat, a source of e.m.f, a milliammeter, a voltmeter and connecting wires. Draw a circuit diagram to show how photoelectric effect may be demonstrated in the laboratory.

b) In a photoelectric effect experiment, a certain surface was illuminated with radiation of different frequencies and the stopping potential determined for each frequency.

Table 2 shows the results obtained.

Table 2.

Frequency, f ( $\times 10^{14}$ HZ)	7.95	7.41	6.88	6.10	5.49
Stopping Potential, $V_s$ (V)	1.35	1.15	0.93	0.62	0.36

(i) Plot the graph of the graph of stopping potential (y-axis) against frequency.

(ii) Determine Planks Constant,  $h$ , and the work function,  $\theta$ , of the surface given that  $eV_s = hf - hf_0$

where  $e = 1.6 \times 10^{-19}$  coulomb and  $hf = \theta$

$f_0$  is the lowest frequency that can cause photoelectric effect.

c) A surface whose work function  $\theta = 6.4 \times 10^{-19}$  joules is illuminated with light of frequency  $3.0 \times 10^{15}$  Hz

Find the maximum Kinetic energy of the emitted photoelectrons (Use the Value of  $H$  obtained in b(ii))

**K.C.S.E 2005**  
**PHYSICS PAPER 232/2**  
**QUESTIONS**

1. a) Describe with aid of a labeled diagram an experiment to determine the focal length of the lens when provided with the following; an illuminated object, convex lens, a lens holder, a plane mirror and a metre rule. (5mks)
- b) A small vertical object is placed 28cm in front of a convex lens of focal length 12cm. On the grid provided, draw a ray diagram to locate the image. The lens position is shown. (Use a scale; 1cm rep re 4cm) (5mks)

Determine the image distance.

- c) Fig 1 shows a human eye with a certain defect

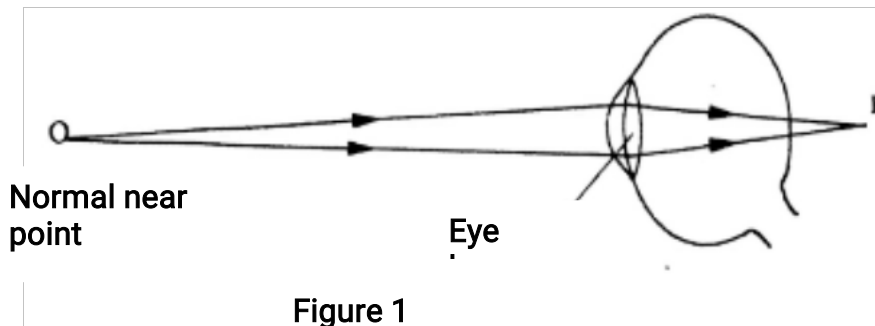

- (i) Name the defect
- (ii) On the same diagram, sketch the appropriate lens to correct the defect and sketch rays to show the effect of the lens. (2mks)
2. a) Fig 2. Shows a wheel and axle being used to raise a load  $W$  by applying an effort  $F$  The radius of the large wheel is  $R$  and of the small wheel  $r$  as shown.

For marking

Fig. 2.

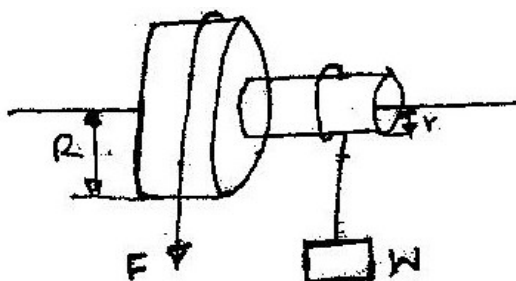

- (i) Shows that the velocity ratio (V.R) of this machine is given by  $R/r$  (3mks)
- (ii) Given that  $r = 5\text{cm}$ ,  $R = 8\text{cm}$ , determine effort required to raise a load of  $20\text{N}$  if the efficiency of the machine is  $80\%$  (4mks)
- (iii) It is observed that the efficiency of the machine increases when it is used to lift large loads. Give a reason for this. (1mk)

3 When the switch is closed determine the:

- (i) Ammeter reading
- (ii) Charge on each conductor (3mks)

4. Explain how doping produces an n-type semi-conductor for a pure semi-conductor material. (3 mks)

b) Fig 5. Shows the circuit of a rectifier using four diodes  $D_1, D_2, D_3$  and  $D_4$ .

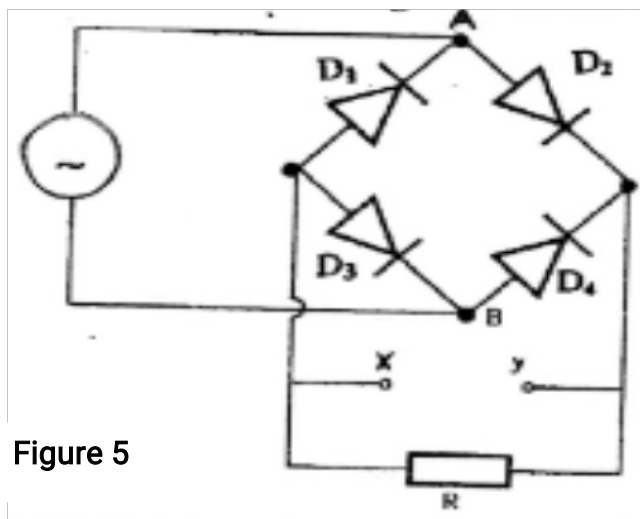

- (i) Explain how a rectified output is produced from the set – up when an a.c input is connected across AB (4 mks)
- (ii) On the axis provided sketch the graph of output voltage against time for rectifier (1 mk)
- (iii) A capacitor is now connected across XY. Explain the effect of the

capacity on the output.  
(2 mks)

- (c) A transistor in a common – emitter amplifier has  $\beta = 120$ . A signal in the input causes the base corresponding change in the output voltage if the load resistance is  $100\Omega$ . (4 mks)

5. (a) State Hooke's law (1 mk)

- (b) One end of a piece of a rubber was fixed to a rigid support and the other end pulled with a force of varying magnitude. The graph in fig 6 shows the relationship between the force (N) and the extension (cm)

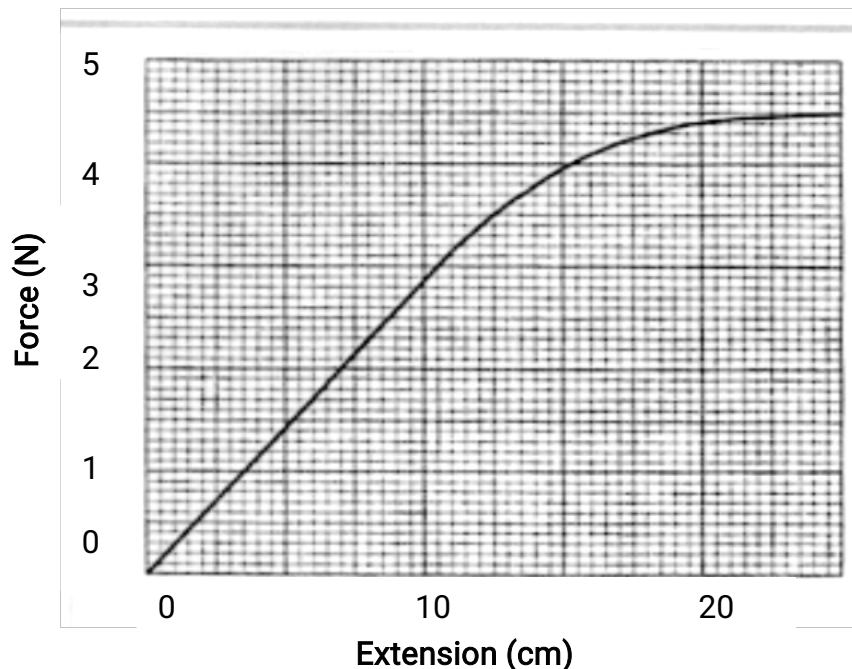

Using the graph, determine

- The stretching force at the elastic limit
  - The tensile stress in the rubber at an extension of 5 cm if the cross-section of the rubber is  $0.25\text{cm}^2$
  - The tensile in the rubber at an extension of 5cm if the original length was 2 m
- (3 mks)

- (c) In Fig 7. girders AB, BC, CD, ED, EB and BD were joined to make the rigid structure shown. The load W hangs from the structure as shown.

For marking sch

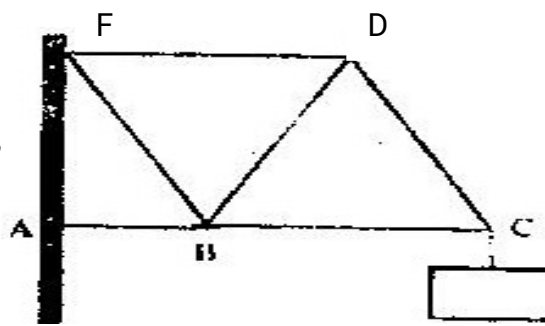

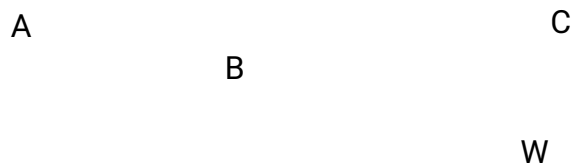

FIGURE 7

Which of the girders can be replaced with strings without affecting the structure?

(2 mks)

**SECTION II (15 MKS)**

*Answer ONE question from this section*

6. (a) Define the term angular velocity

(1 mk)

(b) A body moving with uniform angular velocity is found to have covered an angular distance of 170 radians in  $t$  seconds. Thirteen seconds later it is found to have covered a total angular distance of 300 radians. Determine  $t$ .

(3 mks)

(c) Fig 8 shows a body of mass  $m$  attached to the centre of a rotating table with a string whose tension can be measured. (The device for measuring the tension is not shown in the figure)

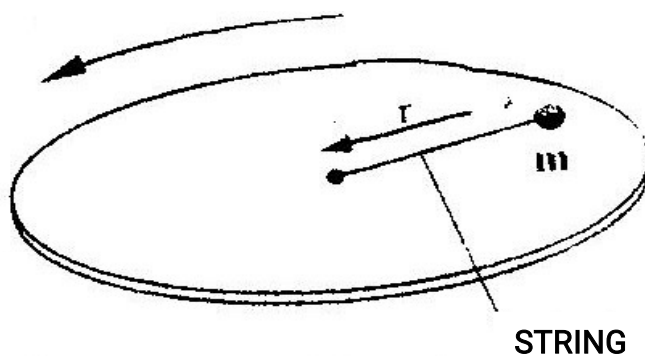

FIGURE 8

The tension,  $T$  on the string was measured for various values of angular velocity,  $\omega$ . The distance  $r$  of the body from the centre was maintained at 30cm. Table 1 shows the results obtained.

**Table 1**

$W^2$	4.0	9.0	16.0	25.0	36.0
Angular velocity $w$ ( $\text{radi}^{-1}$ )	2.0	3.0	4.0	5.0	6.0
Tension $T$ (N)	0.04	0.34	0.76	1.30	1.96

- (i) Plot the graph of  $T$  (y- axis against  $w^2$ ) ( 5 mks)
- (ii) From the graph, determine the mass,  $m$  of the body given that  
 $T = mw^2 - C$   
 Where  $C$  is a constant  
 ( 4 mks)
- (iii) Determine the constant  $C$  and suggest what it represents in the set up.  
 ( 2 mks)
7. (a) What is meant by radioactivity ( 1 mk)
- (b) With an aid of a labeled diagram explain the working of Geiger Muller tube as a detector of radiation ( 5 mks)
- (c) In an experiment to determine the half of a certain radioactivity substance, the activity in disintegrations per minute was measured for sometime. Table 1 shows the results obtained

Time in Minutes	0	10	20	30	40	50	60	70	80
Activity indisintergrations	152	115	87	66	50	38	20	12	6

On the grid plot a suitable graph and use it to determine the half life  $t_{1/2}$  of the substance

( 7 mks)

- (d) At time  $t = 40$  minutes, the activity of a sample of a certain radioactive isotope with a half life 12 minutes is found to be 480 disintegration per minute.  
 Determine the time which activity was 3840 disintegrations per minute

(2 mks)



**K.C.S.E 2006**  
**PHYSICS PAPER 232/2**  
**QUESTIONS**

**SECTION A (25 marks)**

*Answer ALL the questions in this section in the spaces provided*

1. Figure 1 shows two bar magnets placed with the south poles close together

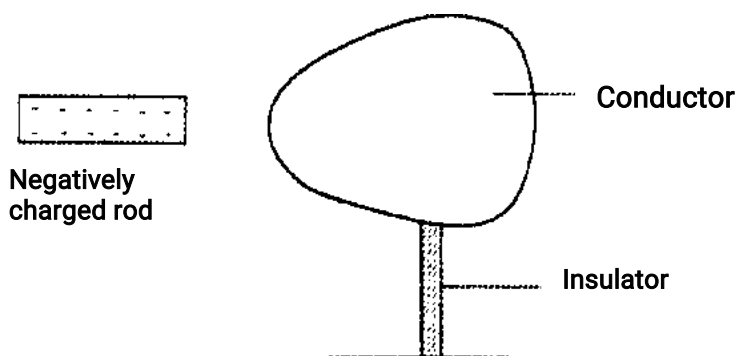

**Figure 1**

In figure 1 sketch the magnetic field pattern between the two south poles

( 1 mk)

2. In a certain pinhole camera, the screen is 10cm from the pinhole. When the camera is placed 6m away from a tree, a sharp image of the tree 16cm high is formed on the screen. Determine the height of the tree.
3. A metallic body shaped as shown in figure 2 is positively charged and insulated from the ground as shown in the figure.



**Figure 8**

On the figure show the charge distribution  
( 1 mk)

4. State a reason why the caps of the cells of a lead- acid battery are opened when charging the battery. ( 1 mk)
5. A long coil is attached to a vibrating blade as shown in figure 3

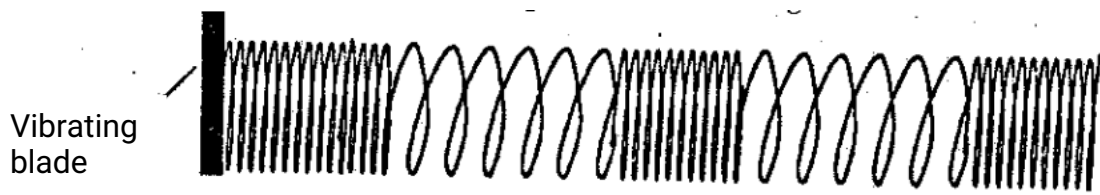

Figure 3

State the type of mechanical wave generated by the set - up and mark alongside the coil, the length corresponding to the wavelength,  $\lambda$  of the wave.

(2 mks)

6. Figure 4 shows a solenoid carrying an electric current.

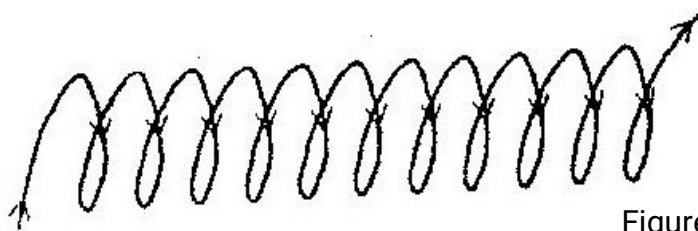

Figure 4

Sketch the magnetic field pattern inside and at the ends of the solenoid

(1 mk)

7. Figure 5 shows wave fronts approaching a concave surface

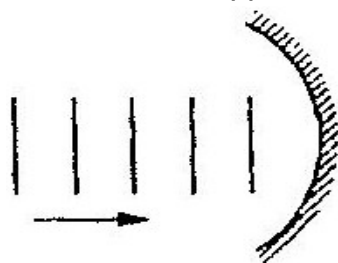

Figure 5

Complete the diagram to show the wave fronts formed after striking the surface. Show how the focal point of the surface is located

(2 mks)

8. A soldier standing some distance from a wall, blows a whistle and hears its echo 1 seconds later. How far is the wall from the soldier? ( speed of sound in air is  $330\text{ms}^{-1}$ ) (3 mks)
9. State one condition under which Ohm's law is obeyed in a metal conductor (1 mk)

Use the information given below to answer questions 10 and 11  
 The Kinetic energy (K.E) of an electron, ejected from the surface of a metal illuminated by radiation of frequency  $f$  is given by

$$K. E = hf - \phi$$

Where  $h$  is Planck's constant and  $\phi$  is the work function of the surface

10. What is meant by the term work function? (1 mk)
11. If the frequency of the illuminating radiation is just equal to the threshold frequency of the surface explain why no photoelectric effect is observed (2 mks)

Figure 6 shows a tube for investigating the properties of a beam of electrons. Use the information in the figure to answer questions 12 and 13

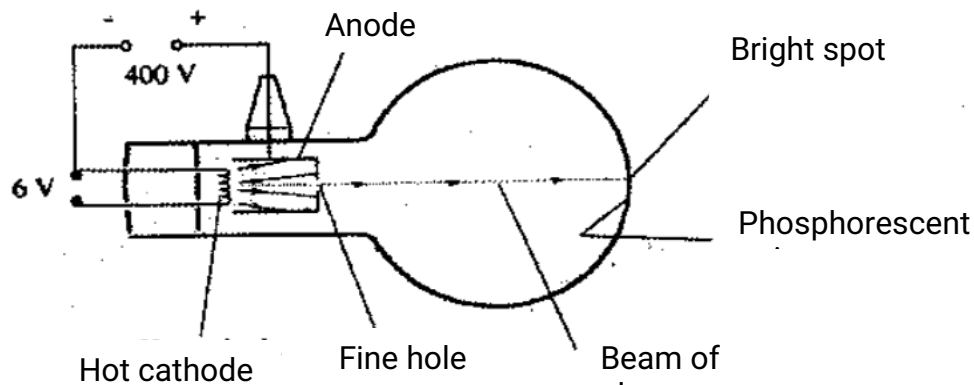
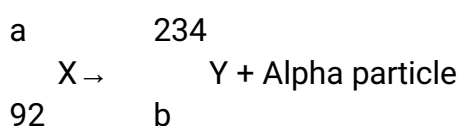

Figure 6

12. What property of the beam of electrons show that the electrons are traveling at a very high speed?
13. The beam of electrons is subjected to a strong magnetic field which is perpendicular to the path and into the paper. Sketch on the same figure, the new path of electrons. (1 mk)
14. State with a reason the effect on the X-rays produced in an X-ray tube, when the p.d across the tube is increased (2 mks)
15. A nuclear reaction is represented by the following equation



Determine the values of a and b

( 2 mks)

16. In the axes provided sketch the current – voltage characteristics for reverse – biased p- n junction

( 1 mk)

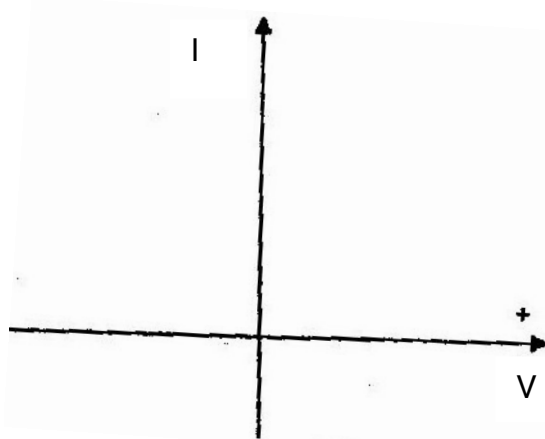

**SECTION B (55 MKS)**

*Answer all questions in this section in the spaces provided*

17. Figure 7 shows a circuit where a battery of emf 4.5V, switches A and B, two capacitors  $C_1 = 0.3\mu\text{F}$  and  $C_2 = 0.5\mu\text{F}$  and a voltmeter are connected

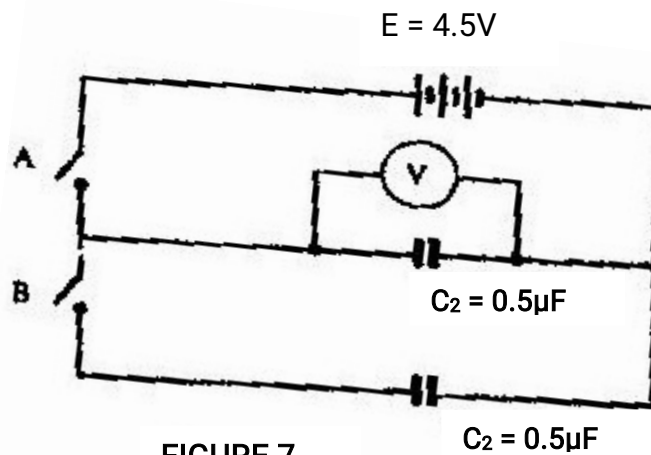

**FIGURE 7**

(a) Determine the charge on  $C_1$  when switch A is closed and switch B is open

(3 mks)

(b) What is the effective capacitance  $C_t$  when both switches A and B are closed?

(c) State what is observed on the voltmeter when

(i) switch A is closed and switch B is open (1 mk)

(ii) Switch A is closed and opened, and then B is closed (1 mk)

(iii) Explain the observation made in c (ii) above (2 mks)

18. Figure 8 shows an object placed in front of a concave mirror of focal length 10cm. C is the centre of curvature.

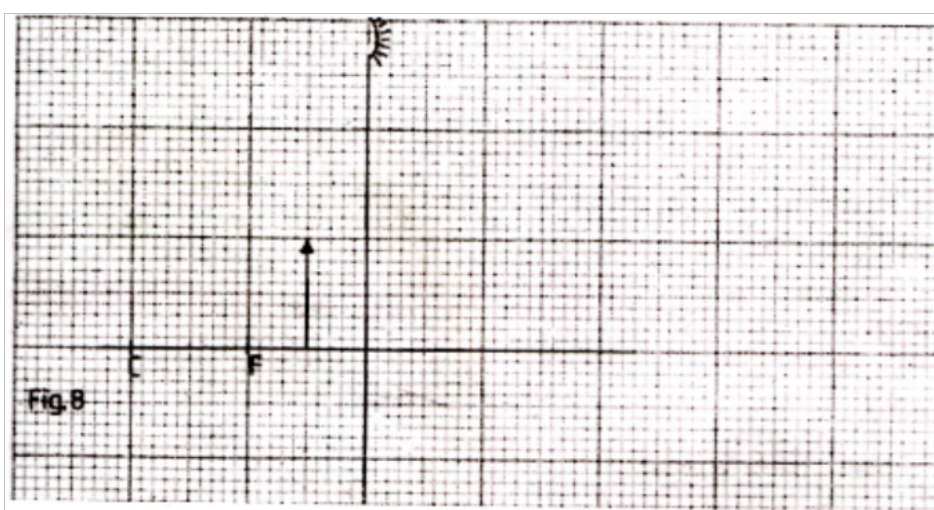

(i) On the same figure draw a ray diagram showing the location of the image (4 mks)

Use the ray diagram drawn in (i) above to determine the

(ii) Image distance (2 mks)

(iii) Magnification (2 mks)

(b) A vertical object is placed 20cm in front of a convex lens of focal length 5 cm

(i) Determine

I. The image distance (3 mks)

II. The magnification (2 mks)

(ii) State two characteristics of the image

(2 mks)

19. (a) Define the refractive index of a substance  
(1 mk)

(b) In an experiment to determine the refractive index of a liquid, the liquid was poured into a measuring cylinder. A pin was placed at the bottom of the cylinder and another pin was used to locate the apparent position of the first pin. The real depth and apparent depth were measured. The experiment was repeated with other values of real depth. The table below shows the results obtained.

Real depth (cm)	5	10	15	20	25
Apparent depth (cm)	3.3	6.7	10	13.3	16.7

(i) Plot the graph of real depth against apparent depth

(5 mks)

(ii) From the graph determine the refractive index of the liquid

(4 mks)

(c) Figure 9 shows a ray of light incident on a glass – air interface

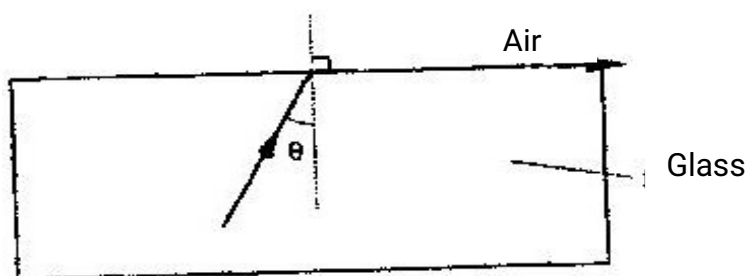
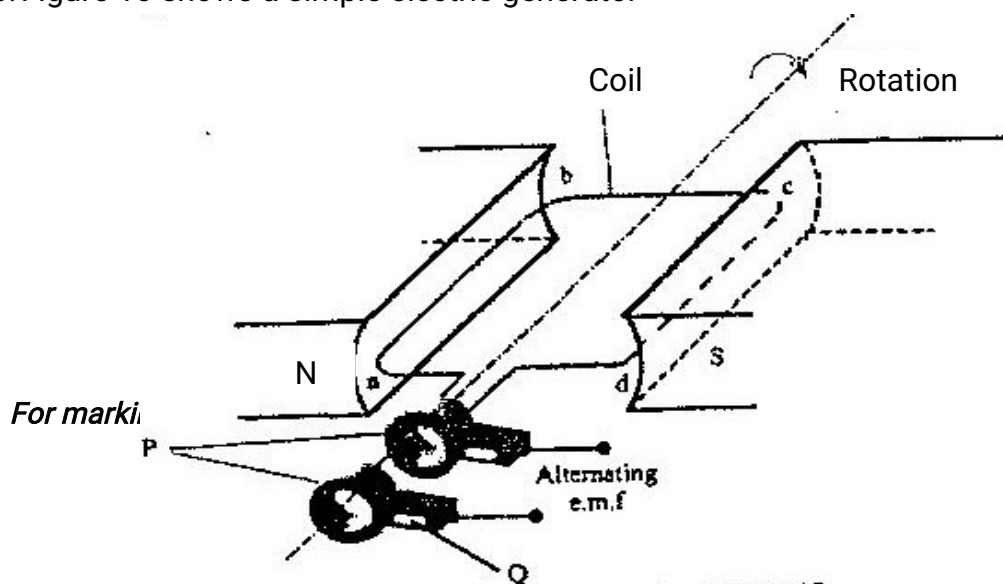

Figure 9

Given that the refractive index of the glass is 1.6. Determine angle  $\theta$   
(3 mks)

20. Figure 10 shows a simple electric generator



P

Alternating e.m.f

Figure 10

(a) (i) Name the parts labeled P and Q (2 mks)

(ii) The e.m.f generated as the coil rotates is represented in the graph in figure

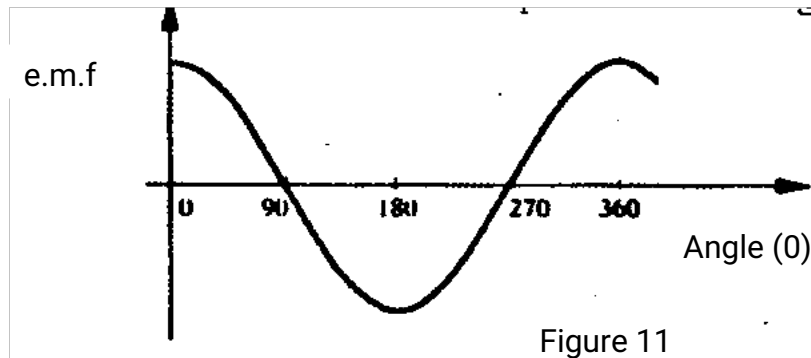

Give reasons for the changes in emf as the coil rotates from  $0^\circ$  to  $90^\circ$  and  $90^\circ$  to  $180^\circ$

(b) The primary coil of a transformer has 1200 turns and the secondary coil has 60 turns. The transformer is connected to a 240V. a.c source.

Determine

(i) The output voltage

(2 mks)

(ii) The output current when the primary coil has a current of 0.5A. (Assume there are no energy losses. (3 mks)

21. (a) Figure 12 shows a section of a house wiring system

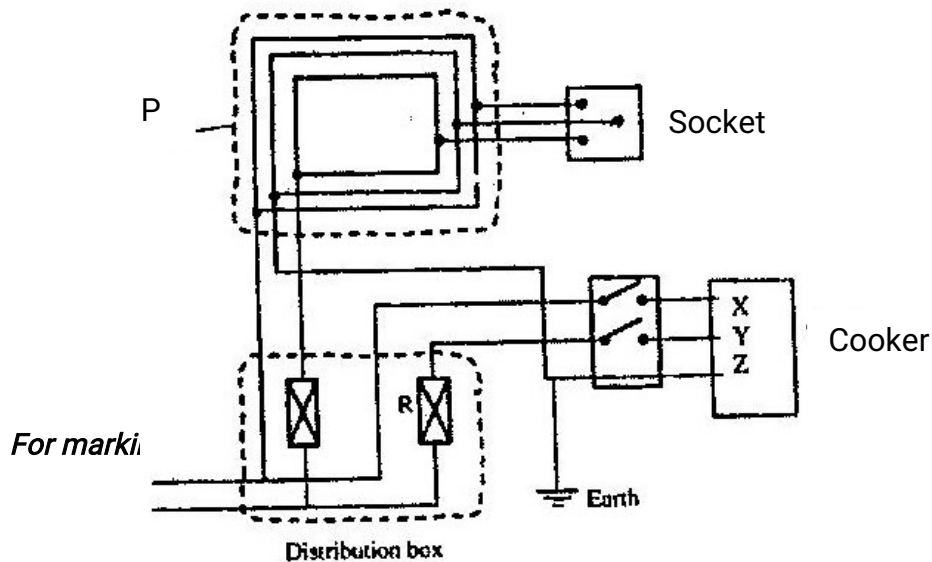

Figure 12

Earth  
Distribution  
**Figure 12**

- (i) Name:  
The circuit labeled P (1 mk)  
The terminals labeled X and Y  
X.....Y..... (2 mks)

II Give a reason why R is connected to Y but not to X (1 mk)

(ii) Why is the earthing necessary in such a circuit?  
(1 mk)

- (b) Determine the cost of using an electric iron rated 1500W, for a total of 30 hours  
given that the cost of electricity per kWh is Kshs 8.  
(2 mk)



**K.C.S.E 2007**  
**PHYSICS PAPER 232/2**  
**QUESTIONS**

**SECTION A (25 MKS)**

*Answer all the questions in this section in the spaces provided*

1. Figure 1 represents a pinhole camera

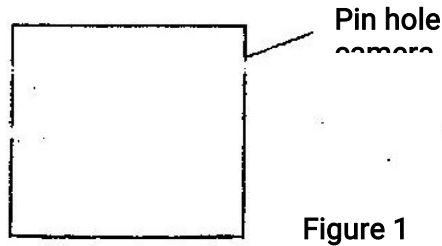

Sketch rays to show the formation of an enlarged image in the camera.  
 Label both the object and the image  
 (2 mks)

2. State one advantage of an alkaline cell over a lead – acid cell  
 (1 mk)

3. Figure 2 shows a horse – shoe magnet whose poles are labeled and two other magnets near it.  
 Iron are attracted to the lower ends of the magnets as shown.

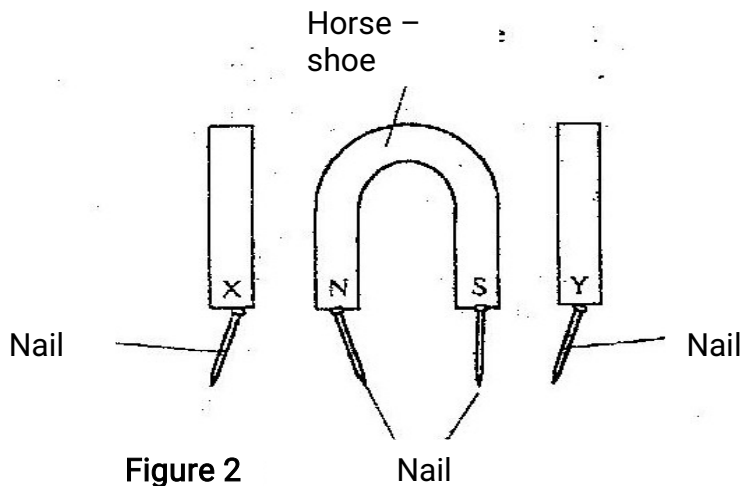

Identify the poles marked X and Y

(1 mk)

X ..... Y.....

4. Figure 3 shows an object, O in front of a concave mirror and its image, I formed after reflection.

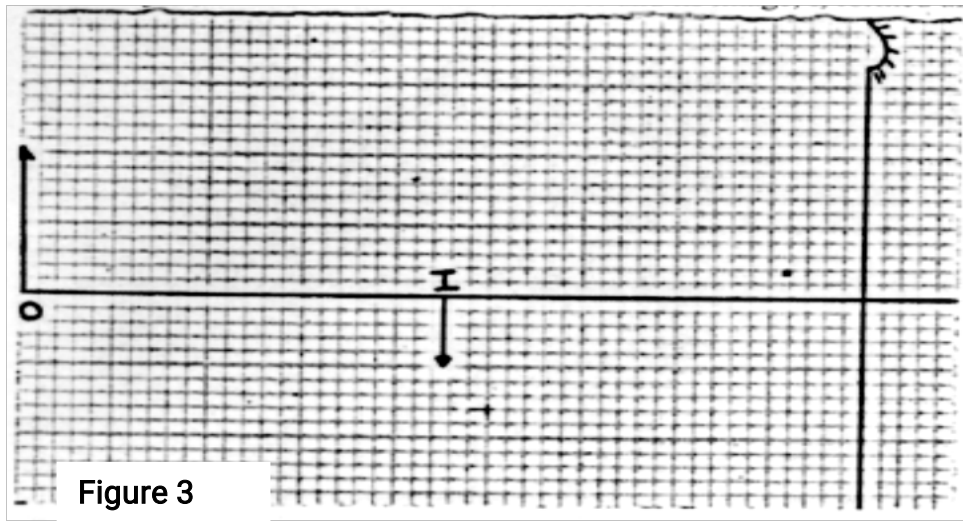

Figure 3

- (a) On the same diagram draw appropriate ray (s) to locate the principal focus, F, of the mirror. (2 mks)
- (b) Determine the focal length of the mirror (scale 1: 5) (1 mk)
5. Figure 4. shows the displacement – time graph for a certain wave

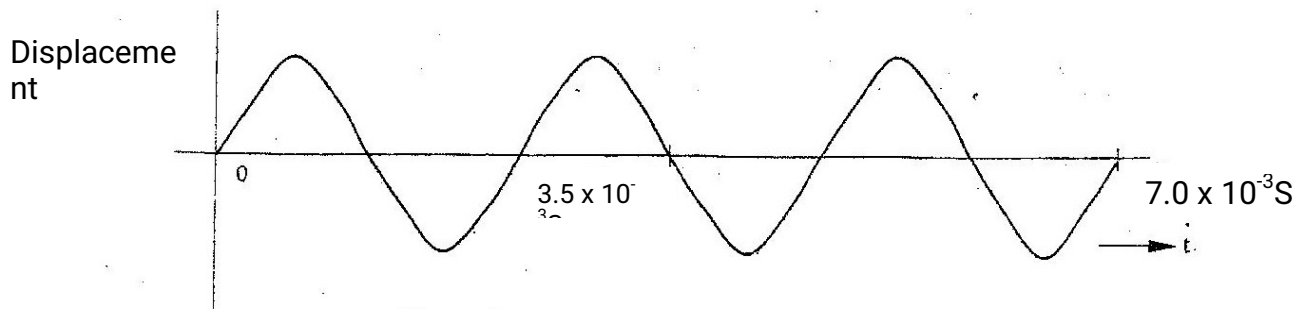

Figure 4

Determine the frequency of the wave (3 mks)

6. Figure 5 (a) and (b), show wave fronts incident on barriers blocking part of the path.

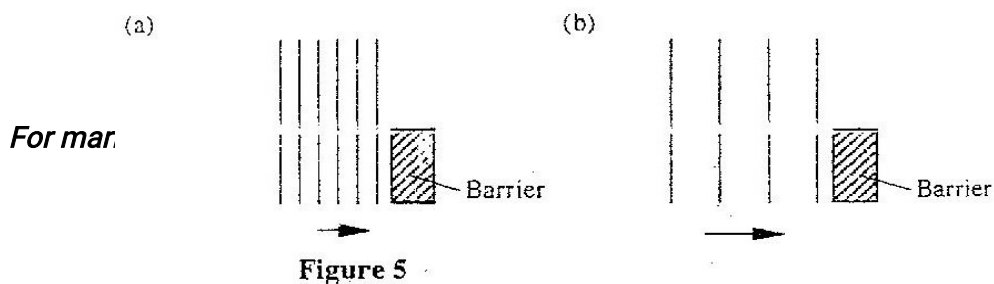

Figure 5



Determine the internal resistance of the cell  
(3 mks)

9. A heater of resistance  $R_1$  is rated  $P$  watts,  $V$  volts while another of resistance  $R_2$  is rated  $2P$  watts,  $V/2$  volts. Determine  $R_1 / R_2$   
(3 mks)
10. State what is meant by the term accommodation as applied to the human eye.  
(1 mk)
11. The graph in figure 8 shows the variation of photoelectric current with applied voltage when a surface was illuminated with light of a certain frequency. Use the information in the figure to answer questions 11 and 12.

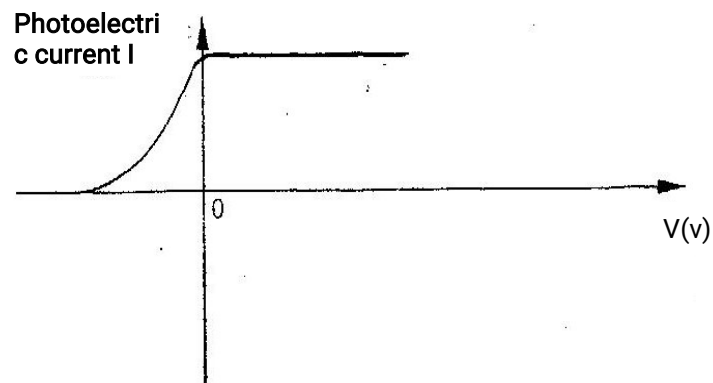
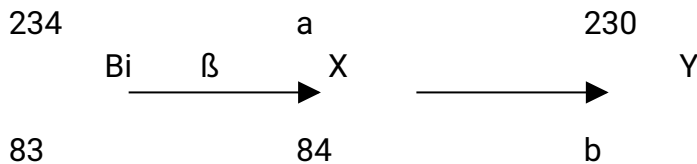

Figure 8

On the same axes, sketch the graph when light of higher intensity but same frequency is used to illuminate the surface.  
(1 mk)

12. Explain your answer in 11 above (1 mk)
13. The following is part of radioactive decay series



Determine the values of  $a$  and  $b$  (2 mks)  
 $a = \dots\dots\dots$   $b = \dots\dots\dots$

14. You are provided with a diode, a resistor  $R$ , an a.c source of low voltage and connecting wires.  
In the space provided, sketch the circuit diagram for a half – wave rectifier

and indicate the terminals where the output voltage  $V_0$  may be connected.  
(2mks)

**SECTION B (55 MKS)**

*Answers ALL the questions in this section in the spaces provided.*

15. (a) State Ohm's Law

(1 mk)

(b) The graph in figure 9 shows the current – voltage characteristics of a certain device, X

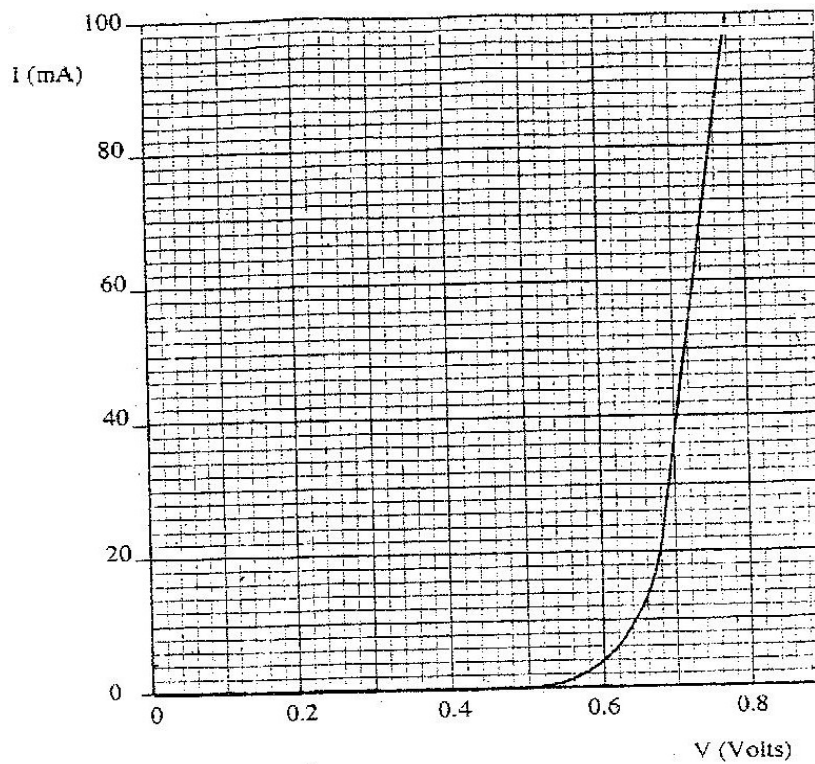
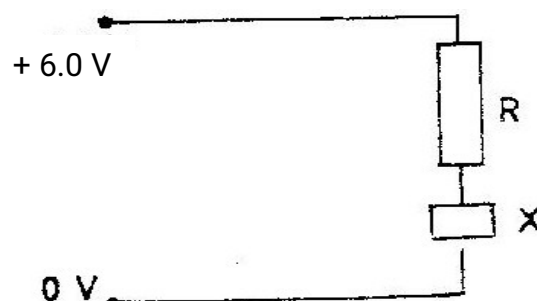

Figure 9

(i) State with a reason whether the device obeys Ohm's law  
(2 mks)

(ii) Determine the resistance of the device, X, when the current through it is 60 mA.

(iii) When the device, X is connected in the circuit below, the voltage across it is 0.70 V.



*For marking sch*

R

X

0 V

Calculate the value of the resistance R.

(3 mks)

- (c) The cell in figure 10 has an e.m.f of 2.1 V and negligible internal resistance.

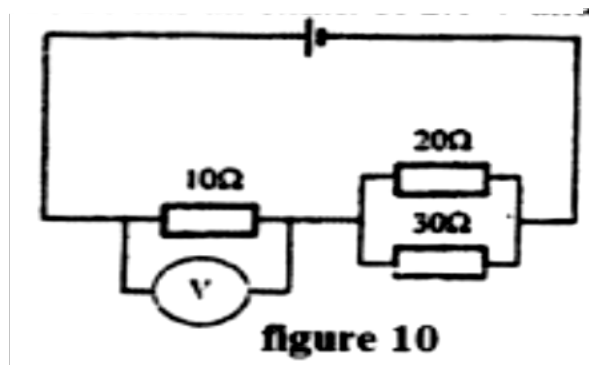

Determine the

- (i) Total resistance in the circuit (2 mks)
- (ii) Current in the circuit (1 mk)
- (iii) Reading of the voltmeter (2 mks)

16. (a) Figures 11 (a) and (b) show diagrams of the human eye

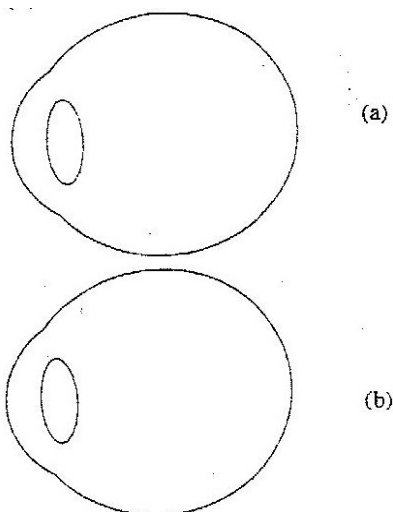

**Figure 11**

- (i) Sketch in figure 11 (a) a ray diagram to show shortsightedness (1 mk)
- (ii) Sketch in figure 11 (b) a ray diagram to show how a lens can be used to correct the shortsightedness (2 mks)

(b) Figure 12 shows the features of a simple camera

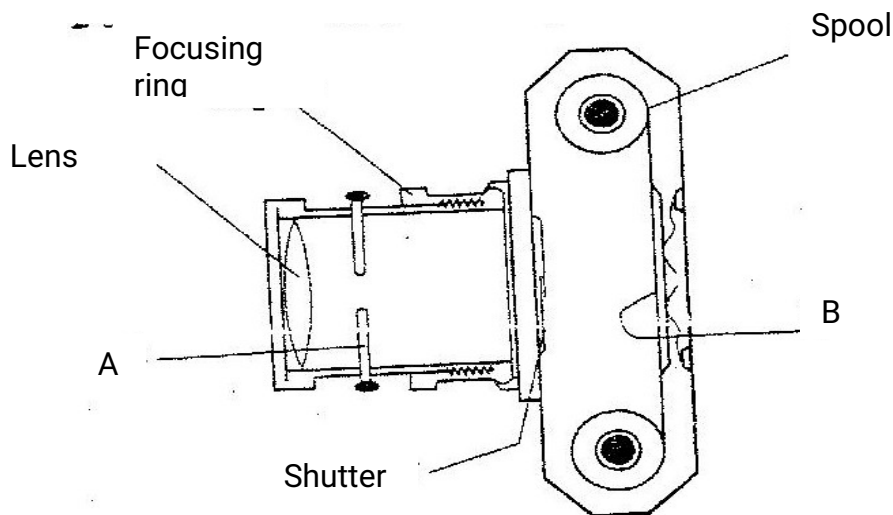

Figure 12

(i) Name the parts labeled A and B

(2 mks)

- A .....
- B .....

(ii) A still object is placed at a certain distance from the camera. Explain the adjustments necessary for a clear image of the object to be formed.

(iii) State the functions of the shutter and the parts labeled A and B  
(3 mks)

- Shutter .....
- A.....
- B .....

(c) A lens forms a clear image on a screen when the distance between the screen and the object is 80cm. If the image is 3 times the height of the object, determine.

(i) The distance of the image from the lens

(3 mks)

(ii) The focal length of the lens

(2 mks)

17. (a) State Lenz's Law of electromagnetic induction

(1 mk)



- (b) Figure 13 shows a simple microphone in which sound waves from the person talking cause the cardboard diaphragm to vibrate

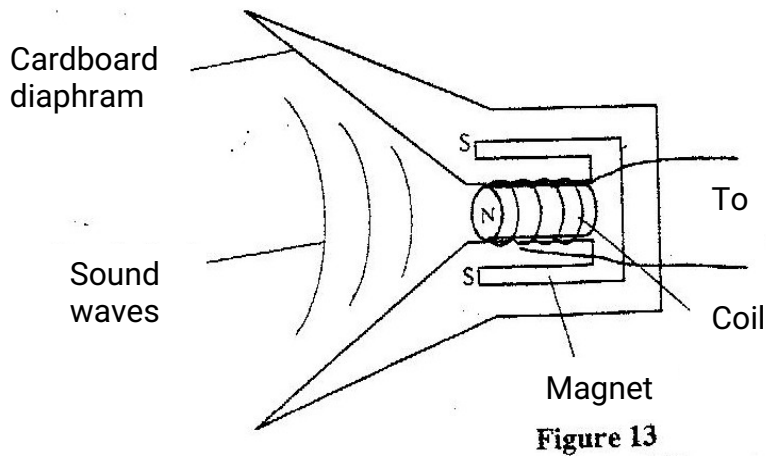

- (i) Explain how a varying current is induced in the coil when the diaphragm vibrates (3 mks)
- (ii) State two ways in which the induced current in (i) above can be increased
- (c) A transformer with 1200 turns in the primary circuit and 120 turns in the secondary circuit has its primary circuit connected to a 400V a.c source. It is found that when a heater is connected to the secondary circuit, it produces heat at the rate of 600w. Assuming 100% efficiency, determine the:
- (i) Voltage in the secondary circuit (2 mks)
- (ii) Current in the primary circuit (2 mks)
- (iii) The current in the secondary circuit (1 mk)

18. (a) Figure 14 shows the features of a cathode ray tube

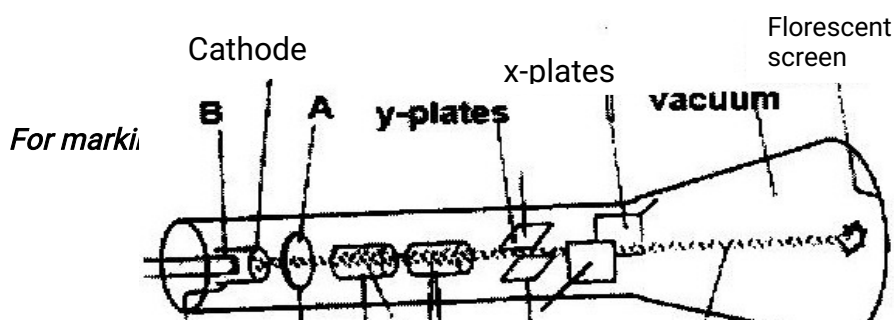

v-plates

Vacuum

Anode

Beam

- (i) Name the parts labeled A and B (2mks)  
A ..... B.....
- (ii) Explain how the electrons are produced in the tube (2 mks)
- (iii) State two functions of the anodes (2 mks)
- (iv) At what part of the cathode ray tube would the time be connected?
- (v) Why is a vacuum created in the tube? (1 mk)
- (b) The graph in figure 15 was obtained on a cathode ray oscilloscope (CRO) screen when the output of an a.c generator was connected to the input of the CRO. The time- base calibration of the CRO was set at 20 milliseconds per centimeter and the y- gain at 5 volts centimeter.

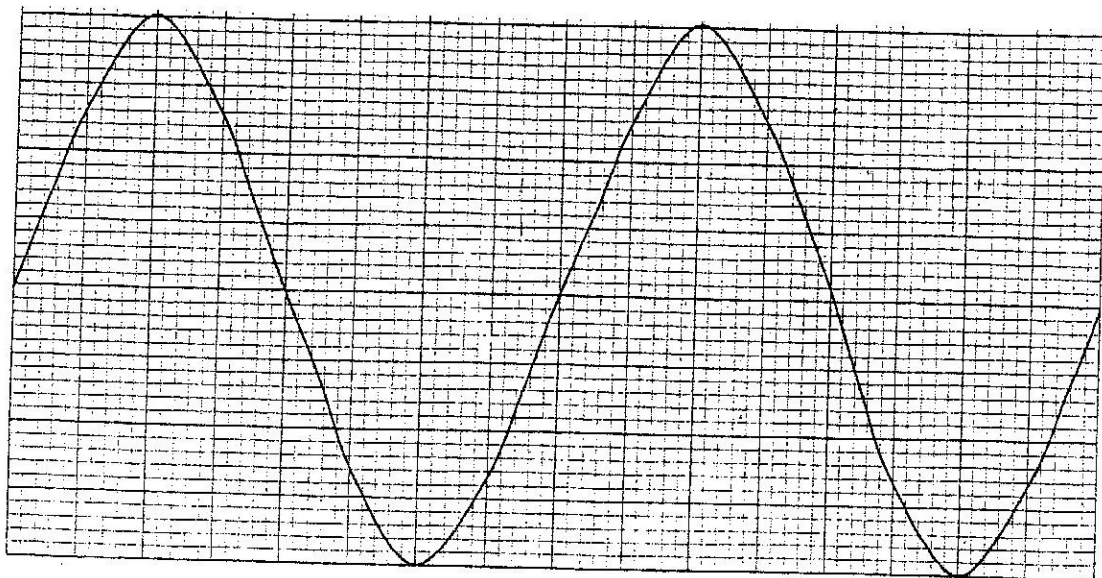

Figure 15

- (i) Determine the peak voltage of the generator (2mks)

- (ii) Determine the frequency of the voltage (3 mks)  
On the same grid, redraw the graph for the same voltage when the time base calibration is set at 40 milliseconds per centimeter and y- gain at 10 volts per centimeter. (Show at least one complete cycle)  
(2 mks)

**K.C.S.E 2008**  
**PHYSICS PAPER 232/2**  
**QUESTIONS**

**SECTION A (25 MARKS)**

*Answer all the questions in this section in the spaces provided.*

1. Figure 1 shows three point sources of light with an opaque object placed between them and the screen.

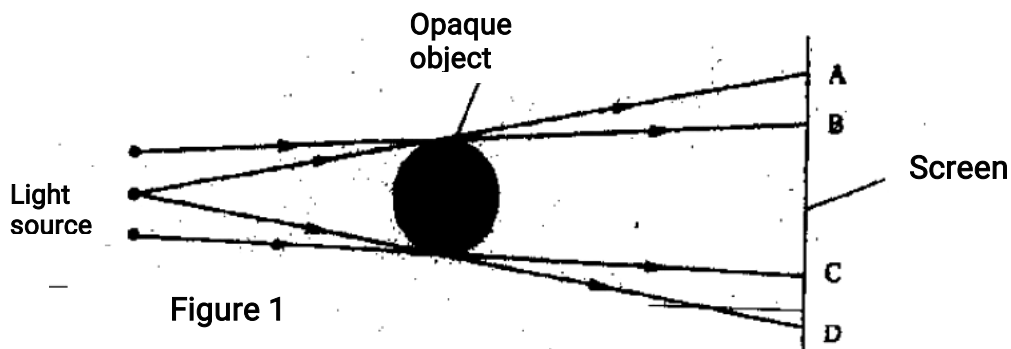

Explain the nature of the shadow formed along B and C.  
 (2mks)

2. A leaf electroscope A is charged and placed on the bench. Another uncharged leaf electroscope B is placed on the same bench and moved close to A until the caps touch. State and explain what is observed on the leaves of A and B.  
 (2mks)
3. You are provided with the following;  
 A cell and holder, a switch, a rheostat, an ammeter, a voltmeter and connecting wires. Draw a diagram for a circuit that could be used to investigate the variation of the potential difference across the cell with the current drawn from the cell.  
 (1mk)
4. An un-magnetized steel rod is clamped facing North-South direction and then hammered repeatedly for some time. When tested, it is found to be magnetized. Explain this observation.  
 (2mks)
5. The diagram in figure 2 shows an object O placed in front of a converging lens. F and F are the principal foci for the lens.

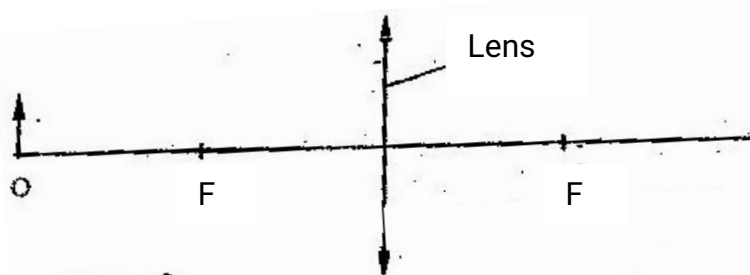
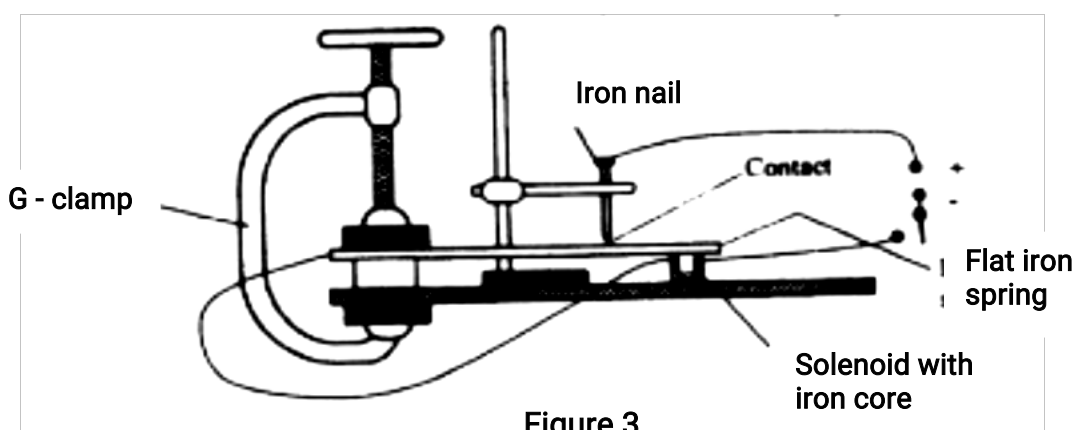

**Figure 2**

The object is now moved along the principal axis until a virtual image is produced. On the same diagram:

- (i) Draw the object O in the new position along the principal axis;
  - (ii) Sketch rays to show formation of the virtual image
- (1mk)

6. Figure 3 shows a flat spring made of iron clamped horizontally on the bench over a solenoid.



When the switch is closed, the spring vibrates. Explain this observation. (3mks)

7. Figure 4 shows a hack-saw blade clamped horizontally on a bench and the free end is made to vibrate about the rest position.

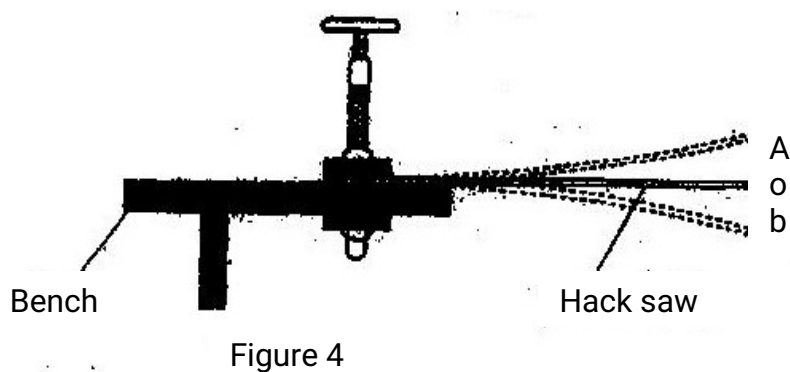

The movement  $o \rightarrow a \rightarrow o \rightarrow b \rightarrow o \rightarrow a \rightarrow o \rightarrow b$  takes 0.7 seconds.

Determine the frequency of vibration of the blade. (2mks)

8. Figure 5 shows wavefronts approaching the boundary between two media.

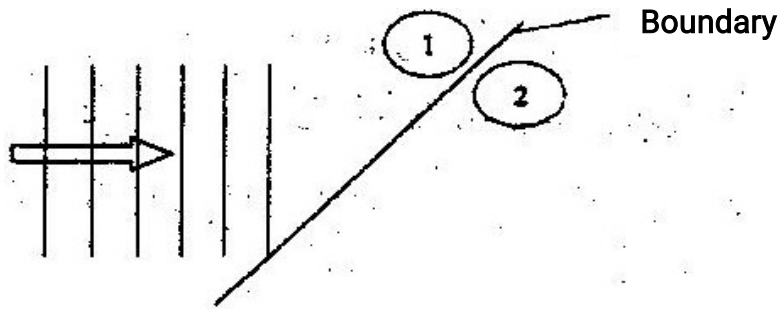

Figure 5

The speed of the waves in medium (2) is higher than that in medium (1). On the same diagram complete the figure to show the wavefronts after crossing the boundary.

(2mks)

9. Figure 6 shows a circuit in which a battery of negligible internal resistance, two resistors, a capacitor, a voltmeter and a switch are connected.

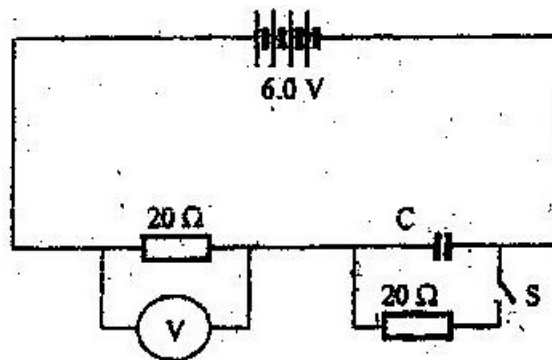

Figure 6

Giving a reason for your answer in each case, state the reading of the voltmeter, V, when the switch is

(2mks)

- (i) Open

V=.....

Reason.....

- (ii) Closed  
 V=.....  
 Reason.....

10. A heating coil is rated 100W, 240V. At what rate would it dissipate energy if it is connected to a 220V supply?  
 (3mks)

11. Figure 7 shows how rays from a distant and a near object are focused inside a human eye with a certain defect.

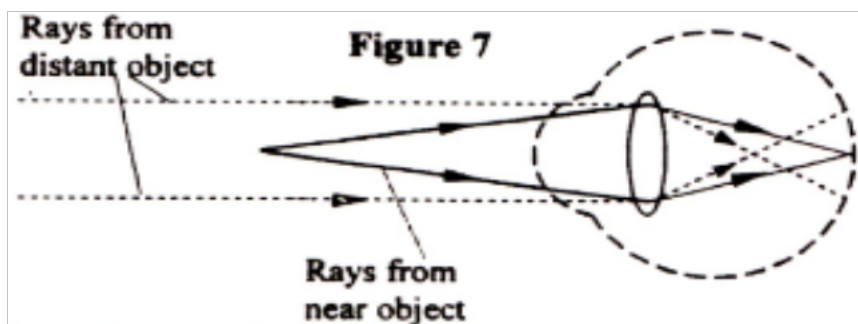

Name the defect and state the cause of this defect.

(1mk)

Defect.....

Cause of defect.....

12. A narrow beam of electrons in a cathode ray oscilloscope (CRO) strike the screen producing a spot. State what is observed on the screen if a low frequency a.c source is connected across the y-input of the CRO  
 (1mk)

13. The accelerating potential of a certain X-ray tube is increased. State the change observed on the X-rays produced.  
 (1mk)

14. A radioactive isotope of copper decays to form an isotope of Zinc as shown below

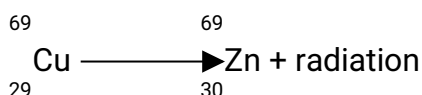

(2mks)

Name the radiation emitted and give a reason for your answer

Radiation.....

Reason.....

**SECTION B (55 MKS)**

***Answer ALL the questions in this section in the spaces provided.***

15. a) State one factor that affects the speed of sound in a solid.  
(1mk)

b) An observer stands half-way between two vertical cliffs that are  $L$  metres apart. He moves directly towards one cliff and after a distance  $x=10\text{cm}$  from the centre, he strikes a gong and measures the time interval,  $t$ , between the echoes heard from the two cliffs. He moves a further  $10\text{m}$  and again strikes the gong and measure the time interval between the echoes. The process is repeated several times. The graph in Figure 8 shows the relation between the time interval,  $t$  and the distance,  $x$  from the centre.



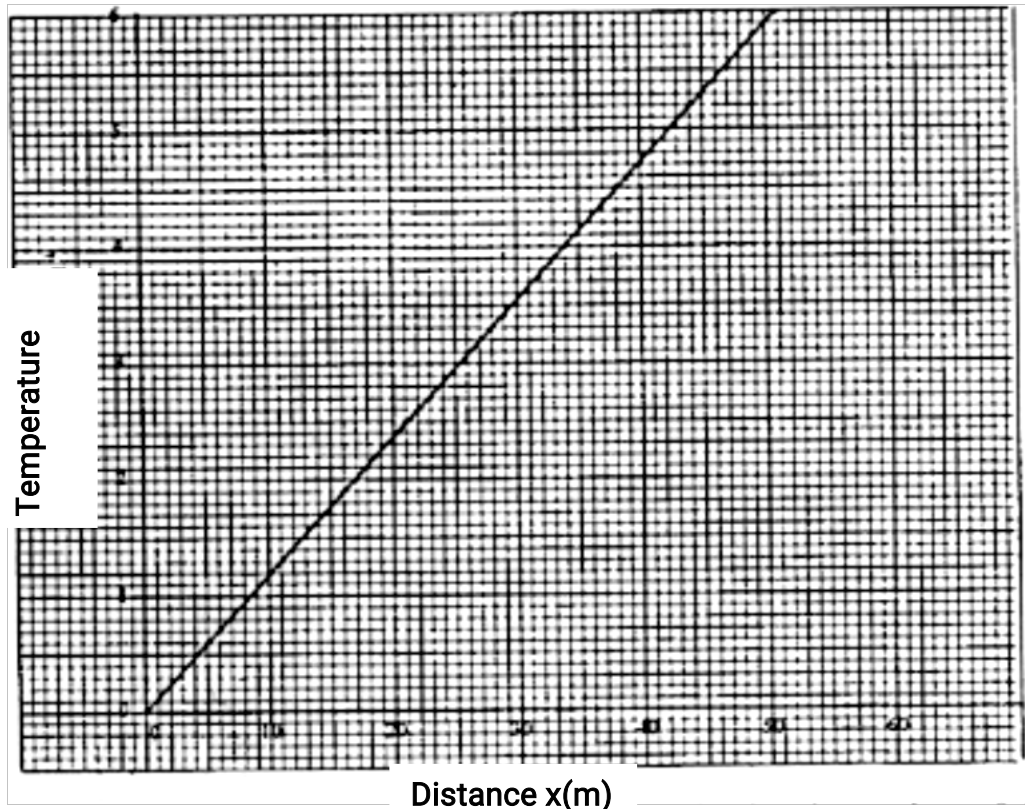

(i) From the graph, determine the value of  $x$  for which the time interval was 0.55. (1mk)

(ii) Given that  $t = \frac{4}{v}x$  where  $v$  is the speed of sound in air, determine the value of  $v$  from the graph. (3mks)

(iii) If the maximum time measured by the observer was  $t = 4.7s$ , determine the distance  $L$  between the cliffs. (3mks)

(c) A search boat uses a signal of frequency  $6.0 \times 10^4 \text{ Hz}$  to detect a sunken ship directly below. Two reflected signals are received; one after 0.1 seconds from sunken boat and the other after 0.14 seconds from the sea bed. If the sea bed is 98 m below the boat, determine:-

(i) The speed of the signal in water. (3mks)  
You may use the value of  $v$  from (ii) above.

(ii) The depth of the sunken ship below the boat (2 mks)

16. (a) State two conditions necessary for total internal reflection to occur (2 mks)

- (b) Figure 9 shows a ray of light incident on the boundary between two media 1 and 2 at an angle  $\theta$

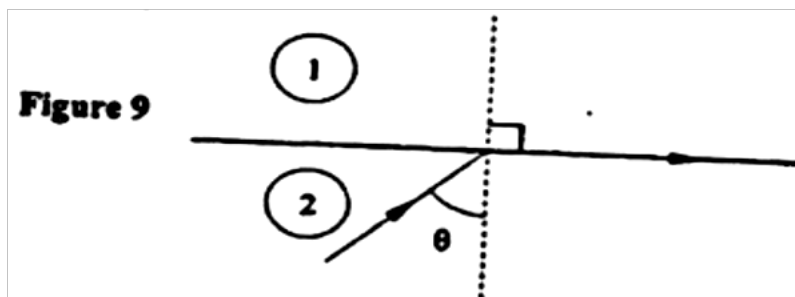

Show that the refractive index for a ray of light traveling from medium 1 to medium 2 is given by:

$$M_2 = \frac{1}{\sin \theta}$$

(2 mks)

- (c) Figure 10 shows a ray of light incident on one face of a block of ice of refractive index 1.31 and totally reflected at the adjacent face

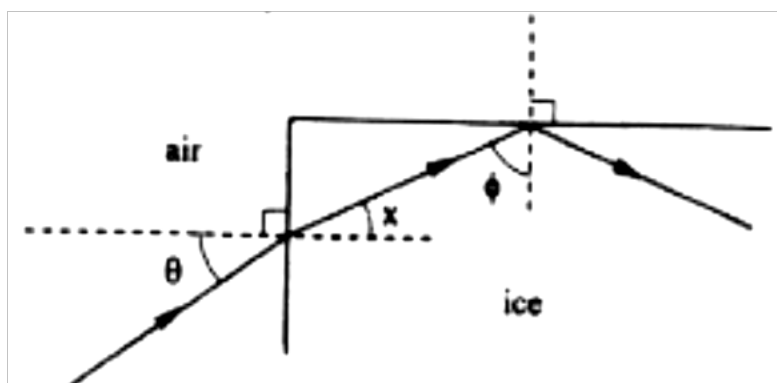

Determine

- (i) Angle  $\Phi$  (2 mks)  
 (ii) Angle  $x$  (1 mk)  
 (iii) Angle  $\theta$ , the greatest angle for which the total internal reflection is possible (2 mks)

17. (a) Three resistors of resistance  $2.0 \Omega$ ,  $4.0 \Omega$  and  $6.0 \Omega$  are connected together in a circuit.

Draw a circuit diagram to show the arrangement of the resistor which Gives

- (i) Effective resistance of  $3.0 \Omega$   
(1 mk)
- (ii) Minimum resistance  
(1 mk)

- (b) In figure 11 the voltmeter reads 2.1 V when the switch is open. When the switch is closed, the voltmeter reads 1.8 V and the ammeter reads 0.1A.

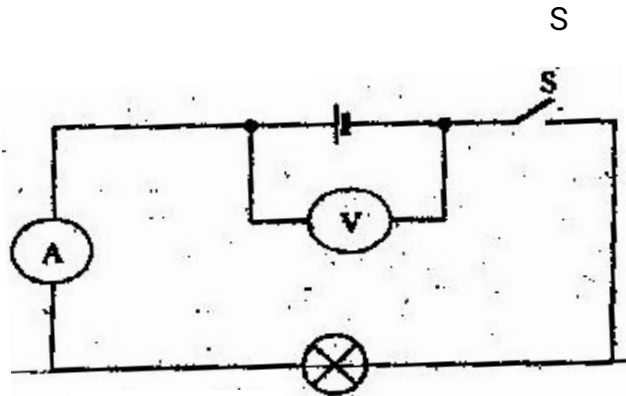

Figure 12

Determine:

- (i) The e.m.f of the cell (1 mk)
- (ii) The internal resistance of the cell (3 mks)
- (iii) The resistance of the lamp (2 mks)

18. (a) Figure 12 shows two circuits close to each other

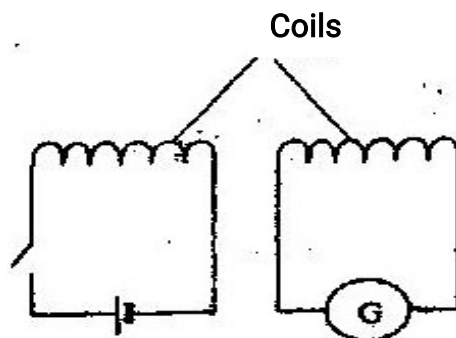

Figure 12

When the switch is closed, the galvanometer shows a reading and then returns to zero. When the switch is then opened, the galvanometer shows a reading in the opposite direction and then returns to zero.

Explain these observations.

(3 mks)

- (b) Explain how energy losses in a transformer are reduced by having:
- (i) A soft- iron core (2 mks)
  - (ii) A laminated core (2 mks)
- (c) An ideal transformer has 2000 turns in the primary circuit and 200 turns in the secondary circuit. When the primary circuit is connected to a 400V a.c. source, the power delivered to a resistor in the secondary circuit is found to be 800W. Determine the current in:
- (i) The secondary circuit
  - (ii) The primary circuit

19. (a) X- rays are used for detecting cracks inside metal beams
- (i) State the type of the X- rays used (1 mk)
  - (ii) Give a reason for your answer in (i) above (1 mk)

- (b) Figure 13 shows the features of an X- ray tube

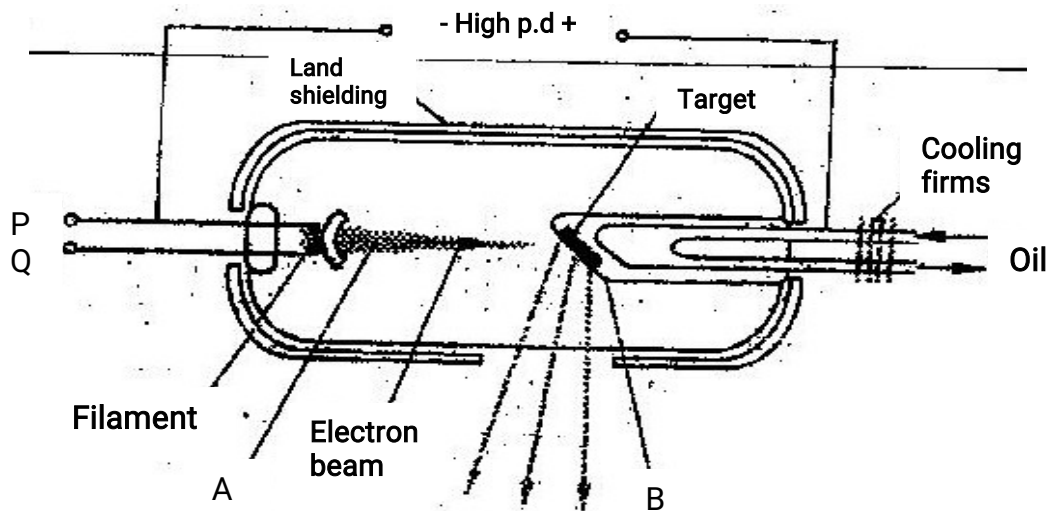

Figure 13 x-rays

- (i) Name the parts labeled A and B (2 mks)
  - A
  - B
- (ii) Explain how a change in the potential across PQ changes the intensity of the X- rays produced in the tube. (2 mks)
- (iii) During the operation of the tube, the target becomes very hot. Explain how this heat is caused (2 mks)
- (iv) What property of lead makes it suitable for use as shielding material? (1 mk)

- (c) In a certain X-ray tube, the electrons are accelerated by a Pd of 12000V. Assuming all the energy goes to produce X-rays, determine the frequency of the X-rays produced. (Plank's constant  $h = 6.62 \times 10^{-34}$  Js and charge on an electron,  $e = 1.6 \times 10^{-19}$ C). (4 mks)

**K.C.S.E 2009**  
**PHYSICS PAPER 232/2**  
**QUESTIONS**

**SECTION A (25 MKS)**

*Answer all the questions in this section in the spaces provided*

1. State the number of images formed when an object is between two plane mirror placed in parallel (1 mk)
2. Figure 1 shows a ray of light incident on a mirror at an angle of  $45^\circ$ . Another mirror is placed at an angle of  $45^\circ$  to the first one as shown

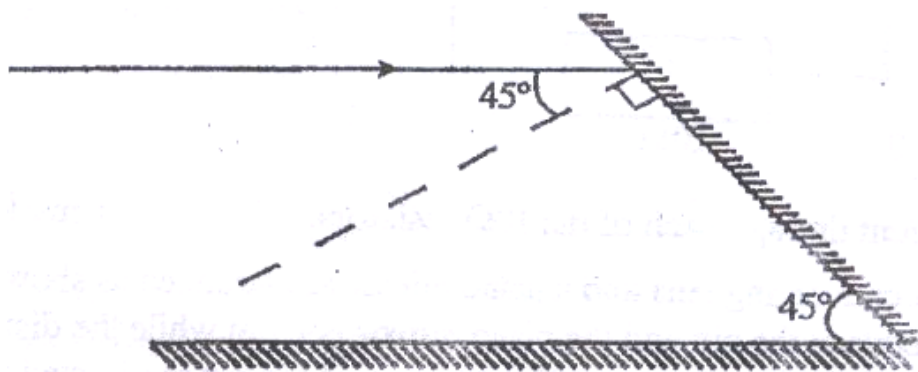
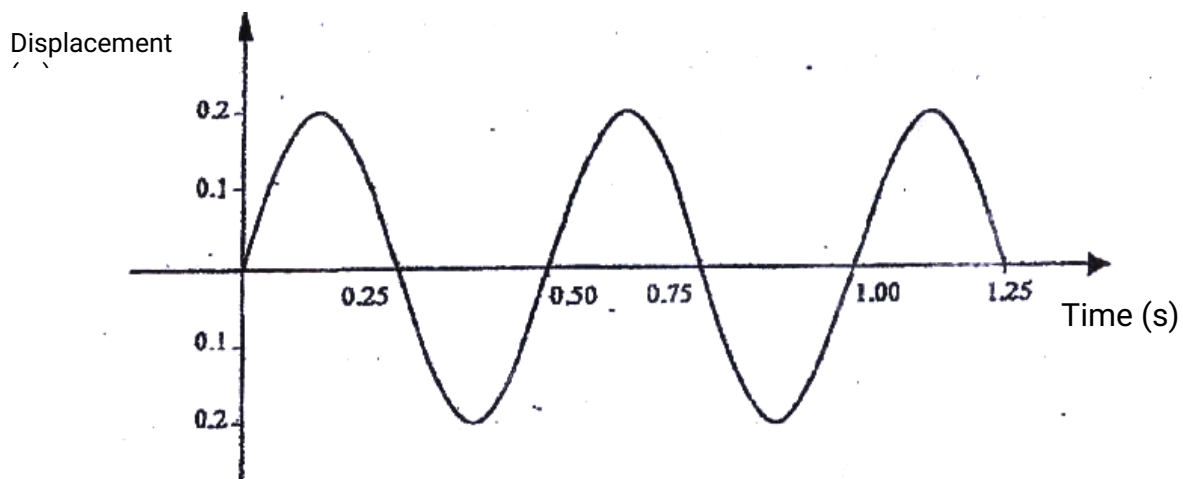

FIGURE 1

- Sketch the path of the ray until it emerges (2 mks)
3. A conductor is slowly brought near the cap of a positively charged electroscope. The leaf first collapses and then diverges. State the charge on the conductor. (1 mk)
  4. Give a reason why it is necessary to leave the caps of the cells open charging an accumulator. (1 mk)
  5. An electromagnet is made by winding insulated copper wire on an iron core. State two changes that could be made to increase the strength of the electromagnet.

( 2 mks)

6. Figure 2 shows how the displacement varies with time for a certain wave



Determine the frequency of the wave  
( 3 mks)

7. Determine the speed of light in water given that the speed of light in air is  $3.0 \times 10^8 \text{ ms}^{-1}$  and the refractive index of water is 1.33 ( 3 mks)
8. Figure 3 shows part of an electrical circuit. The current through the  $18\Omega$  resistor is observed to be 2A.

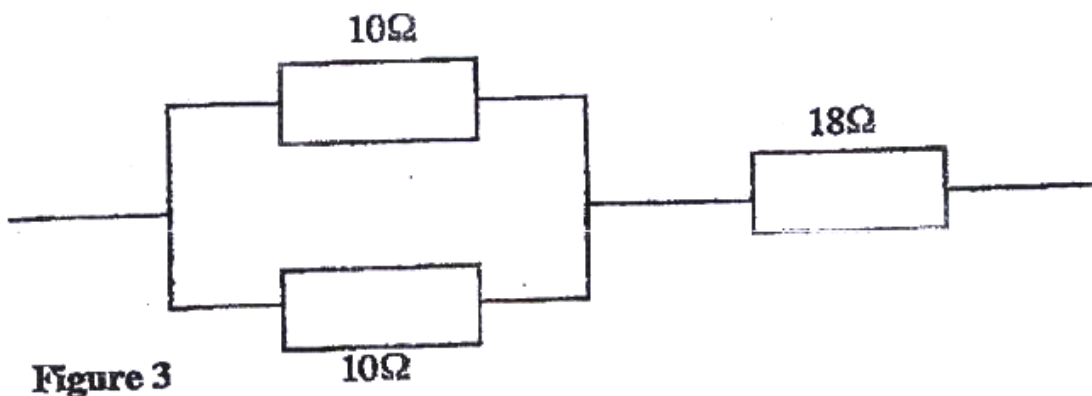

State the value of the current through each of the  $10\ \Omega$  resistors  
(1 mk)

9. In an experiment, a pin a converging lens and a plane mirror are arranged as shown in figure 4. The distance between the pin and the plane mirror is  $L$  cm while the distance between the lens and the plane mirror is  $q$  cm. The position of the pin is adjusted until its tip coincides with its real image. State the focal length of the lens (1 mk)

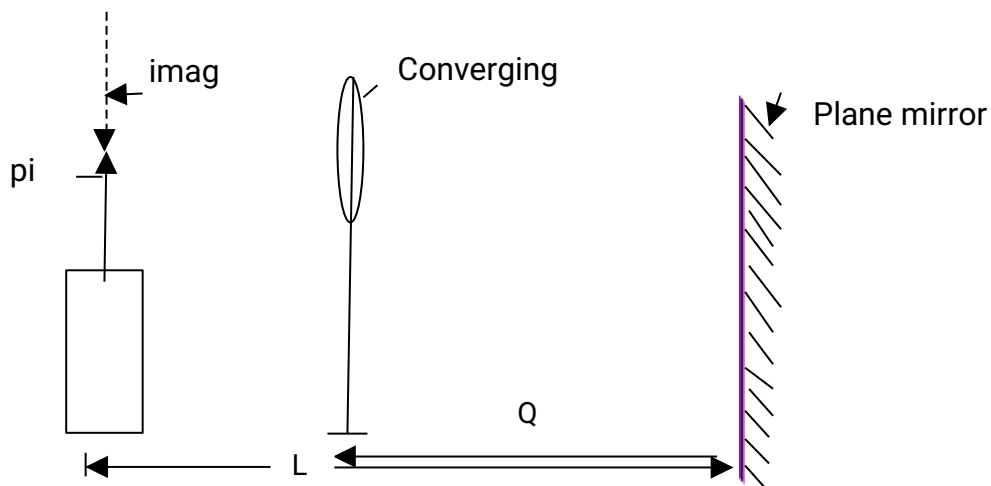

10. Figure 5 shows a magnet being moved towards a stationary solenoid. It is observed that a current flows through the circuit in a direction Q to P.

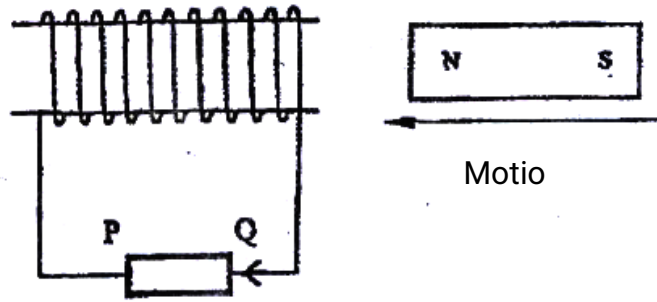

Explain:

- (i) How the current is produced  
( 2 mks)
  - (ii) Why the current flows from Q to P  
( 1 mk)
11. In an X- ray tube it is observed that the intensity of X- rays increases when potential differences across the filament is increased. Explain this observation  
( 3 mks)
12. A boy standing in front of a cliff blows a whistle and hears the echo after 0.5s. He then moves 17 metres further away from the cliff and blows the whistle again. He now hears the echo after 0.6s. Determine the speed of the sound.  
( 3 mks)
13. Figure 6 (a) and figure 6 (b) show a p-n junction to a battery. It is observed that the current in figure 6 (a) is greater than the current in figure 6 (b)

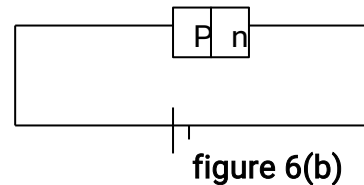
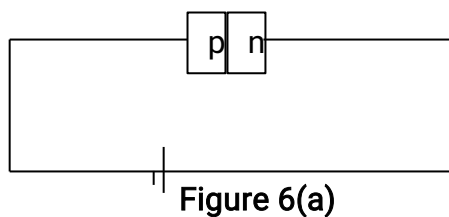

State the reason for this observation  
(1mk)

**SECTION B (55 MKS)**

*Answer all the questions in this section in the spaces provided*



14. (a) Figure 7 shows a pair of parallel plates of a capacitor connected to a Battery the upper plates is displaced slightly to the left.

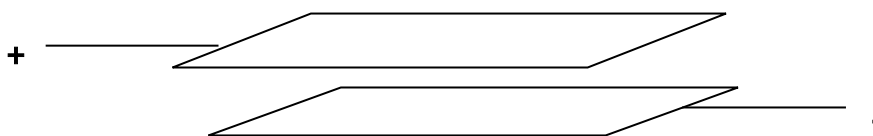

Figure 7

State with reason the effect of this movement of the capacitance  
(2 mks)

- (b) Figure 8 shows an electrical circuit with three capacitors A, B and C of capacitance  $4.0 \mu\text{F}$ ,  $5.0 \mu\text{F}$  and  $3.0 \mu\text{F}$  respectively connected to a 12V battery

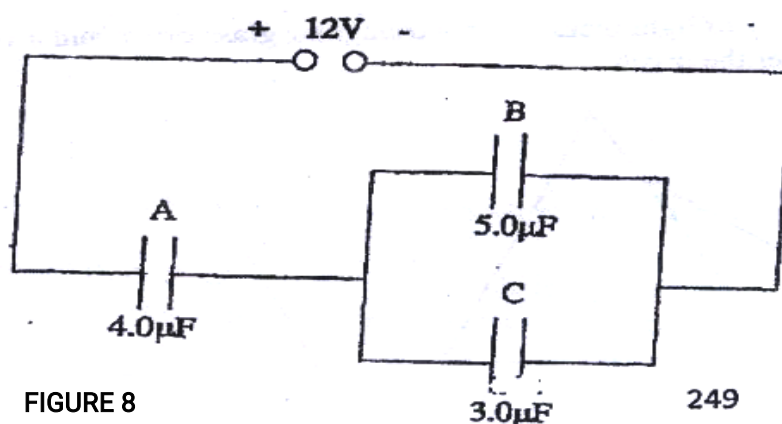

FIGURE 8

249

Determine:

- (i) The combined capacitance of the three capacitors (3 mks)
  - (ii) The charge of the capacitor A (2 mks)
  - (iii) The potential difference across the capacitors B (2 mks)
15. Figure 9 shows the graph of the relationship between current  $I$  and potential difference  $V$  for two tungsten filament lamps X and Y. The normal working voltages for the lamp X and lamp Y are 2.5V and 3.0V respectively.

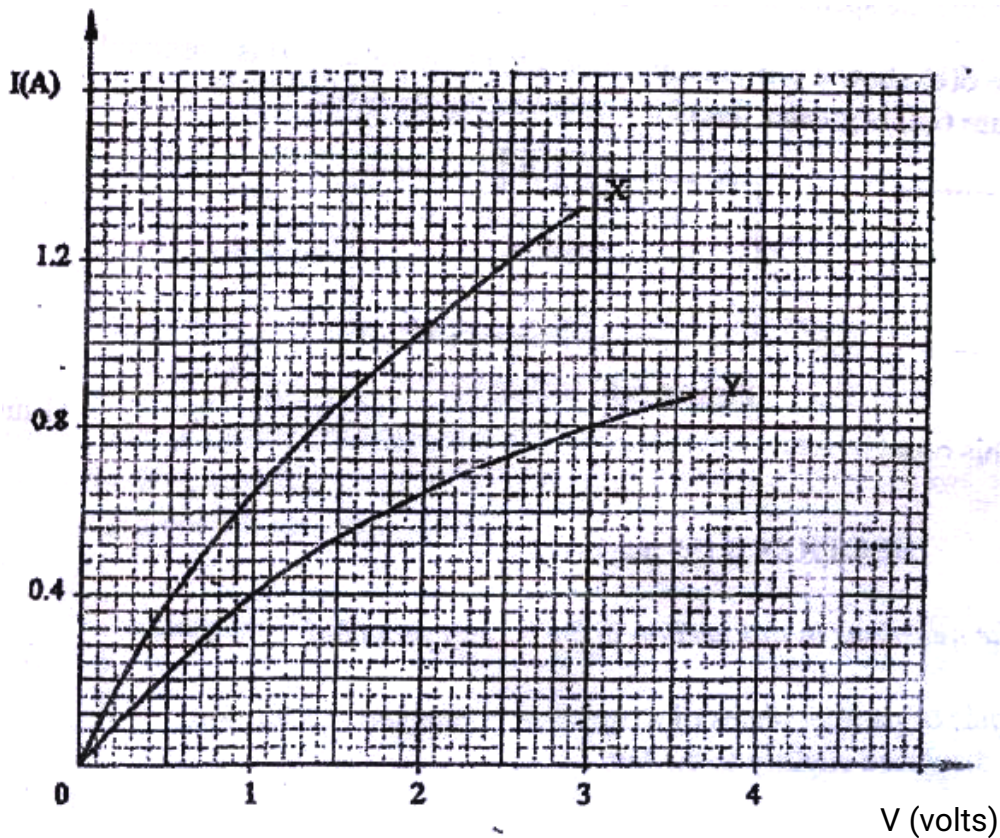

Figure 9

- (a) Explain the change in the shape of the curves as the current increases ( 2 mks)
- (b) Determine the resistance of lamp X at the normal working voltage ( 3 mks)
- (c) The lamps are now connected in a series circuit in which a current of 0.4 A flows. Find the potential differences across lamp Y ( 1 mk)
- (d) Determine the power at which lamp Y operates under normal working voltage ( 2 mks)

16. (a) Figure 10 shows a ray of light incident on a triangular glass prism and white screen S placed after the prism

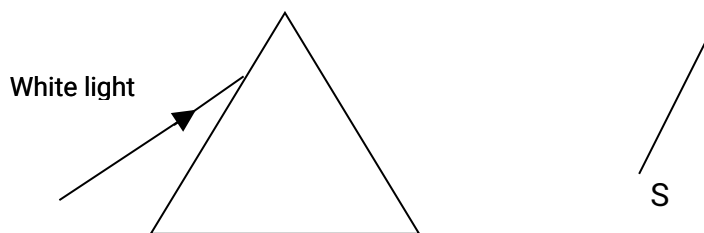

Figure 10

- (i) Complete the path of the ray through the prism to show how a spectrum is formed on the screen ( 3 mks)
- (ii) A thermometer with a blackened bulb is placed at various parts of the spectrum. State with reason the region where the thermometer indicates the highest reading ( 2 mks)
- (b) A pin is placed at the bottom of a beaker of depth 11.5 cm. The beaker is then filled with kerosene. By using another on the side of the beaker and observing from the top, the distance of the image of the pin in the beaker is found to be 3.5 cm from the bottom. Determine the refractive index of kerosene. ( 4 mks)
17. (a) Figure 11 shows the path of radiation from a radioactive source. The field is perpendicular to the paper and directed out of the paper.

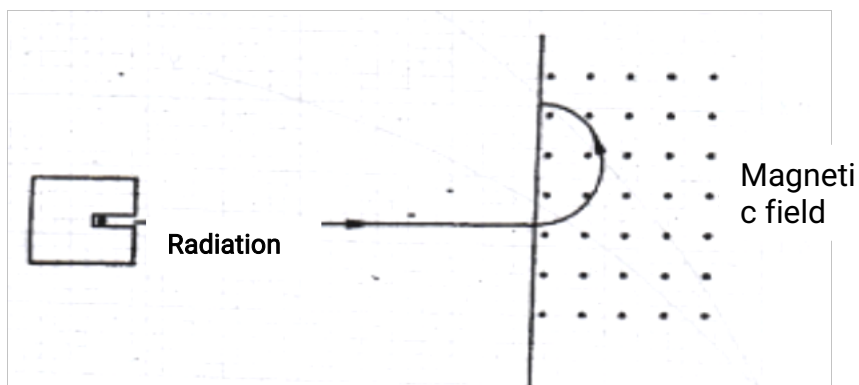
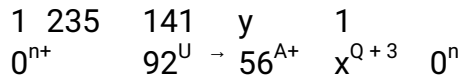

Figure 11

- Identify the radiation ( 1 mk)
- (b) Radiation from a radioactive source enters a G.M tube
- (i) State the effect of the radiation on the gas inside the tube ( 1 mk)
- (ii) Explain how the large discharge current is created ( 2 mk)
- (c) The following is a nuclear equation for a fission process resulting from the reaction of a neutron with a Uranium nucleus



- (i) Determine the values of x and y ( 2 mks)
  - (ii) State the source of the energy released ( 1 mk)
  - (iii) Explain how this reaction is made continuous in a nuclear reactor ( 2 mks)
18. (a) It is observed that when ultra- violet radiation is directed onto a clean zinc plate connected to the cap of a negatively charged leaf electroscope, the leaf falls
- (i) Explain this observation ( 2 mks)
  - (ii) State why this observation does not occur if the electroscope is positively Charged (1 mk)
  - (iii) Explain why the leaf of the electroscope does not fall when infra- red radiation is directed onto the zinc plate ( 1 mk)
- (b) State the effect on the electrons emitted by the photoelectric effect when:
- (i) The intensity of incident radiation is increased ( 1 mk)
  - (ii) The frequency of the incident radiation is increased ( 1 mk)
- (c) The maximum wavelength required to cause photoelectric emission on a metal surfaces is  $8.0 \times 10^{-7} \text{m}$ . The metal surface is irradiated with light of frequency  $8.5 \times 10^{14} \text{ Hz}$ .
- Determine:
- (i) The threshold frequency ( 2 mks)
  - (ii) The work function of the metal in electron volts ( 3 mks)
  - (iii) The maximum kinetic energy of the electrons ( 2 mks)
- Take:  $1\text{eV} = 1.6 \times 10^{-19} \text{ J}$ .  
Speed of light =  $3.0 \times 10^8 \text{ ms}^{-1}$   
Plank's constant,  $h = 6.63 \times 10^{-34} \text{ Js}$
19. Figure 12 shows a set up for observing interference of waves from two sources  $S_1$  and  $S_2$ . The points C and D represent positions of the

constructive and destructive interference respectively as observed on the screen

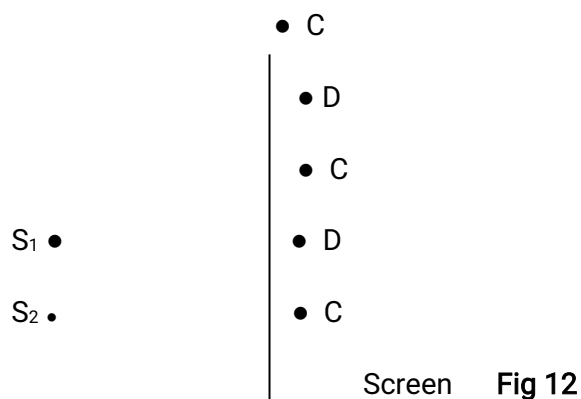

- (a) If the observation was made in a ripple tank, describe:
- (i) How the constructive and destructive interferences are identified ( 1 mk)
- (b) Explain how the constructive interference C and the destructive interference D patterns are produced. ( 2 mks)

Draw:

- (i) The line joining all points where waves from  $S_1$  and  $S_2$  have traveled equal distance. Label it A ( 1 mk)
- (ii) The line joining all points where waves from  $S_2$  have traveled one wavelength further than the waves from  $S_1$ . Label it B. ( 1 mk)

**K.C.S.E 2010**  
**PHYSICS PAPER 232/2**  
**QUESTIONS**

**SECTION A (25 marks)**

*Answer ALL the questions in this section in the spaces provided.*

1. Figure 1, shows a ray of light incident on a plane mirror at O. The mirror is then rotated anticlockwise about O from position  $M_1$  to position  $M_2$  through an angle of  $10^\circ$ . The final reflected ray is OC.

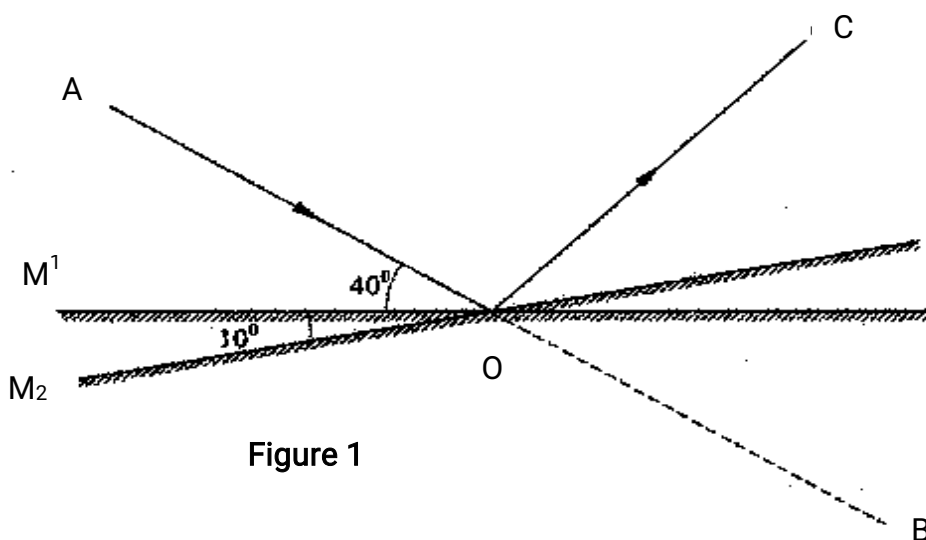

Figure 1

Determine the angle of deviation BOC.

(2mks)

2. Figure 2(a), shows a magnetic compass placed under a horizontal wire XY

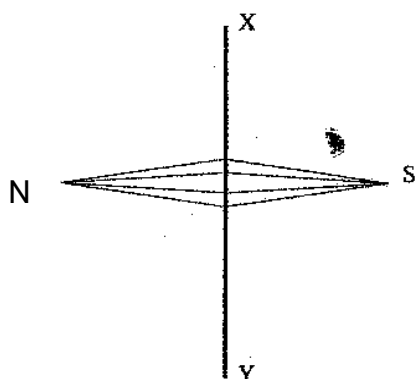

Figure 2(a)

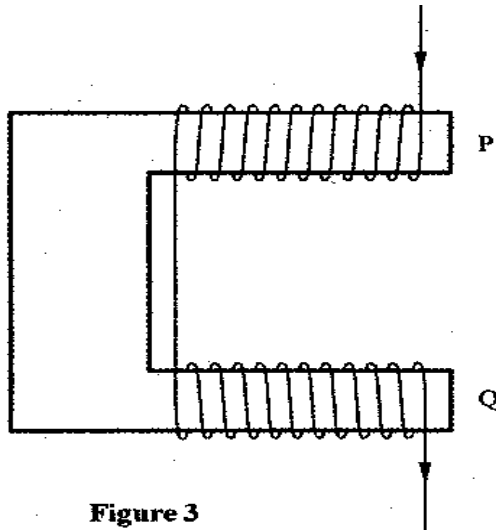

Figure 2(b)

A large current is passed from X to Y. Draw the final position of the magnetic

compass needle in figure  
(1mk)

3. **Figure 3**, shows a diagram of a current-carrying wire wound on a U-shaped soft iron



**Figure 3**

Draw the magnetic field pattern around P and Q.  
(2mks)

4. A positively charged sphere is suspended by an insulating thread. A negatively charged conductor is suspended near it. The conductor is first attracted, after touching the sphere it is repelled. Explain this observation.

(2mks)

5. **Figure 4**, shows a bright electric lamp placed behind a screen which has a hole covered with a wire gauze. A concave mirror of focal length 25cm is placed in front of the screen. The position of the mirror is adjusted until a sharp image of the gauze is formed on the screen.

(2mks)

Image of

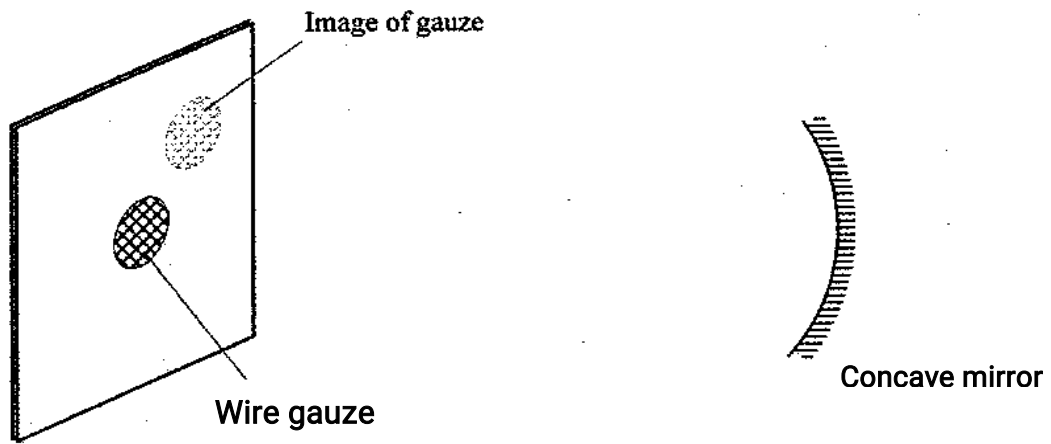

Figure 4

Determine the distance between the mirror and the screen.

(1mk)

6 Explain why electric power is transmitted over long distances at high voltages.

(2mks)

7. **Figure 5**, shows how the displacement of a point varies with time as a wave passes it.

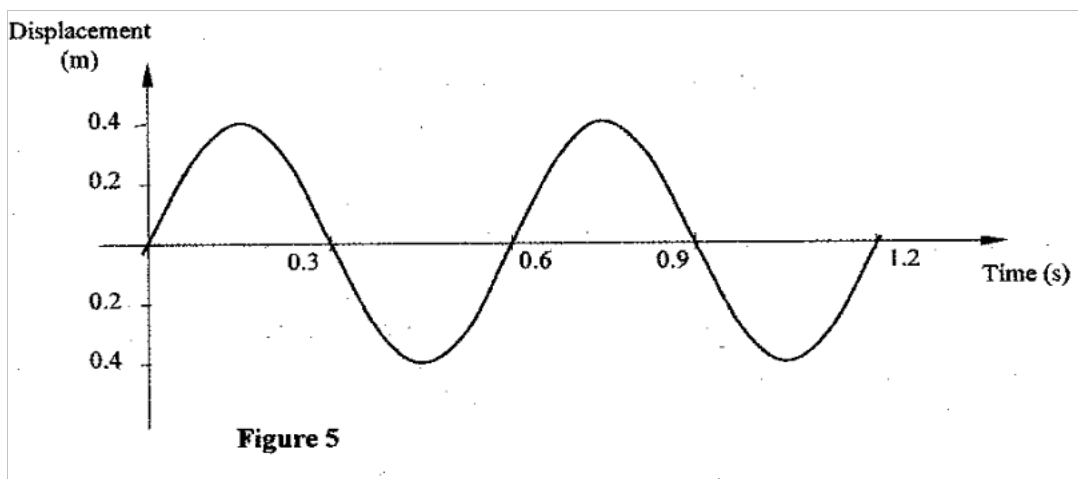

Figure 5

On the same diagram, draw a wave which passes the point with half the amplitude and twice the frequency of the one shown.

(2mks)

8. A water wave of wavelength 18 mm is incident on a boundary of shallow water at right angles. If the wavelength in the shallow end is 14.4 mm, determine the refractive index of water for a wave moving from the deep to the shallow end.

(3mks)



9. The initial mass of a radioactive substance is 20g. The substance has a half-life of 5 years.  
Determine the mass remaining after 20 years.  
(3mks)
10. A current  $I$  flowing through a wire of resistance  $R$  was increased seven times.  
Determine the factor by which the rate of heat production was increased.  
(3mks)
11. **Figure 6**, shows a horizontal conductor in a magnetic field parallel to the plane of the paper.

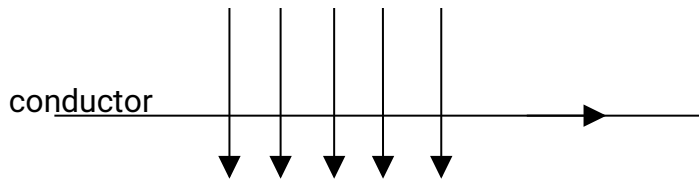

State the direction in which the wire may be moved so that the induced current is in the direction shown by the arrow.  
(1mk)

12. An x-ray tube produces soft x-rays. State the adjustment that may be made so that the tube produces hard x-rays.  
(1mk)
13. The wavelength of a radio wave is 1km. Determine its frequency. (Take the speed of light as  $3.0 \times 10^8 \text{ ms}^{-1}$ ) (2mks)

14. **Figure 7**, shows a block diagram of a p-n junction diode.



On the same diagram, show how a battery may be connected so that the diode is reverse biased.  
(1mk)

### SECTION B (55 mks)

*Answer ALL the questions in this section in the spaces provided.*

15. (a) **Figure 8**, shows a circuit that may be used to charge a capacitor.

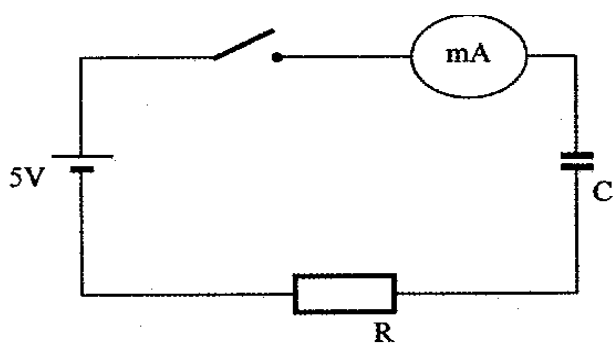

**Figure 8**

- (i) State the observation on the milliammeter when the circuit is switched on:  
(1mk)
- (ii) Explain the observation in (i) above. (2mks)

- (b) The circuit in **figure 8** is left on for some time. State the value of p.d. across:
  - (i) the resistor R;  
(1mk)
  - (ii) the capacitor C; (1mk)

(c) Sketch the graph of potential difference (V) across R against time.  
(3mks)

(d) **Figure 9** shows three capacitors connected to a 10V battery.

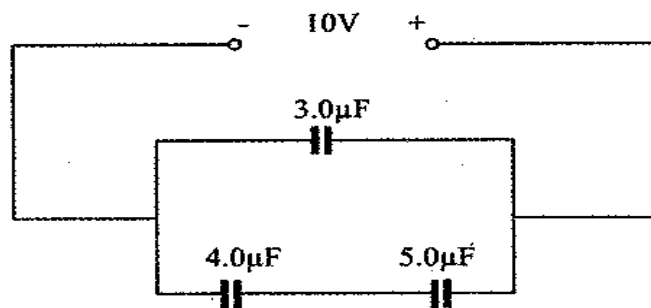
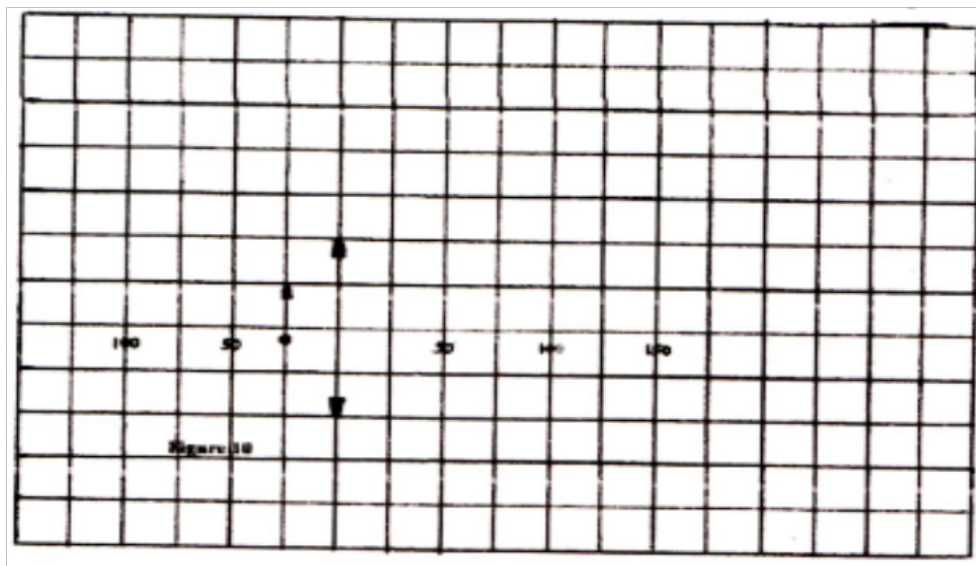

**Figure 9**

Calculate:

- (i) the combined capacitance of the three capacitors;  
 (3mks)
- (ii) the charge on the  $5.0 \mu\text{F}$  capacitor.  
 (2mks)

16. (a) **Figure 10**, shows an object placed in front of a converging lens of focal length  $50\text{mm}$ .



On the same figure, draw a ray diagram showing the location of the image.  
 (3 mks)

- i) Use the diagram to determine the:
- (I) Image distance. (1 mk)
  - (II) Magnification. (2 mks)
- (ii) State the adjustment that should be done to obtain a larger virtual image using the same lens. (1 mk)
- (iv) State one application of the arrangement in **Figure 10**. (1 mk)
- (b) Figure 11, shows a pin  $60 \text{ mm}$  long placed along the principal axis of the lens used in part (a). The near end of the pin is  $80 \text{ mm}$  from the lens

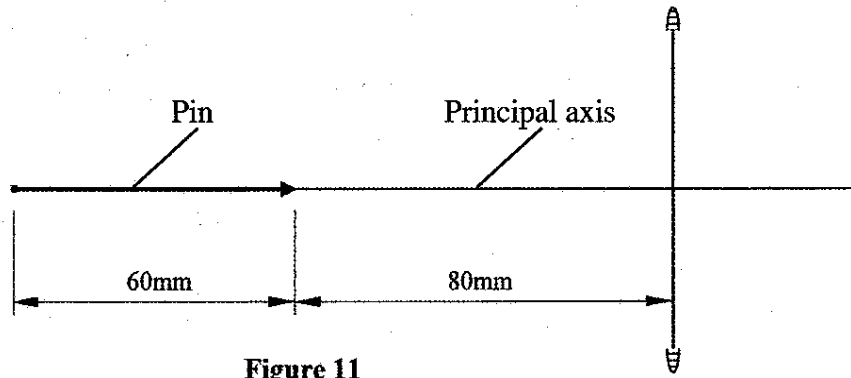

Figure 11

Determine the length of the image.

(2mks)

17. (a) Figure 12, shows an electrical circuit including three switches,  $S_1$ ,  $S_2$ ,  $S_3$ , and three identical lamps  $L_1$ ,  $L_2$ ,  $L_3$ . A constant potential difference is applied across X and Y.

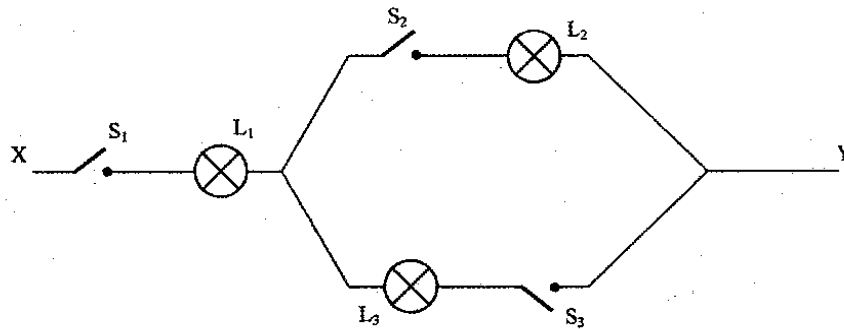
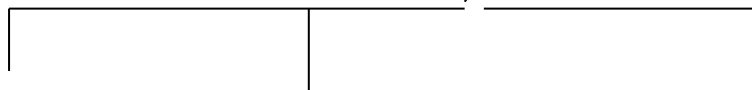
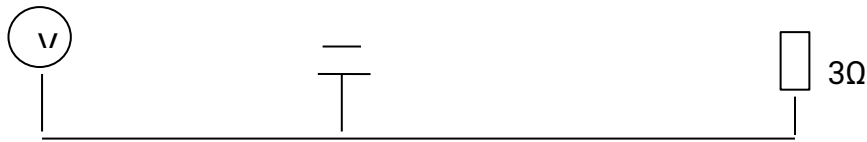

Figure 12

- (i) Other than  $L_1$ , state the lamp that will light when  $S_1$  and  $S_2$  are closed. (1 mk)
- (ii) How does the brightness of  $L_1$  in (i) above compare with its brightness when all the switches are closed? (1 mk)
- (iii) Explain the observation in part (ii) above. (1 mk)

- (b) Figure 13, shows a cell in series with a  $3\Omega$  resistor and a switch. A high resistance voltmeter is connected across the cell.



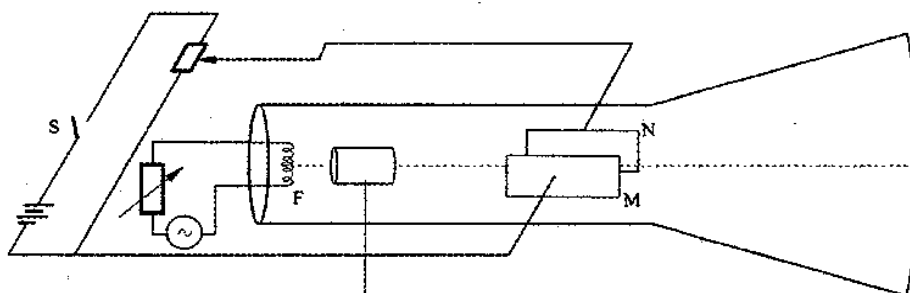

**Figure 13**

The voltmeter reads 1.5V with the switch open and 1.2V with the switch closed.

- (i) State the electromotive force of the cell. (1 mk)
  - (ii) Determine the current through the 3Ω resistor when the switch is closed. (1 mk)
  - (iii) Determine the internal resistance of the cell. (2 mks)
- (c)(i) Another resistor R is connected in series with the 3Ω resistor so that a current of 0.15A flows when the switch is closed. Determine the resistance of R. (3 mks)

18. **Figure 14a**, is a diagram of a cathode ray tube. M and N are parallel vertical plates.



**Figure 14(a)**

+ high voltage

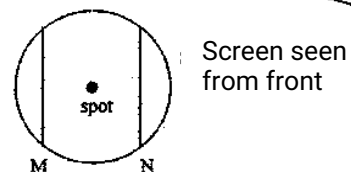

**Figure 14(b)**

- (a) When switch S is open, a spot is seen at the centre of the screen as shown in **figure 14(b)**.
  - (i) State what happens to the spot when S is closed. (1mk)
  - (ii) State what would happen to the spot if the potential difference across MN is increased. (1mk)

(iii) State what would be seen on the screen if the battery is replaced with an alternating emf of:

(I) a low frequency of about 1 Hz; (1mk)

(II) a high frequency of about 50Hz. (1mk)

(b) Explain the process by which electrons are produced at F.  
(2mks)

(c) State with a reason how the brightness of the spot can be increased.  
(2mks)

(d) The accelerating voltage of the tube is 1000V and the electron current in the beam is 1.5mA. Determine the energy conveyed to the screen per second.) (2mks)

19. (a) State the property of radiation that determines the number of electrons emitted when a radiation falls on a metal surface.  
(1mk)

(b) **Figure 15** is a graph of the stopping potential  $V_s$  against frequency in an experiment on photoelectric effect.  
 $V_s$ (volts)

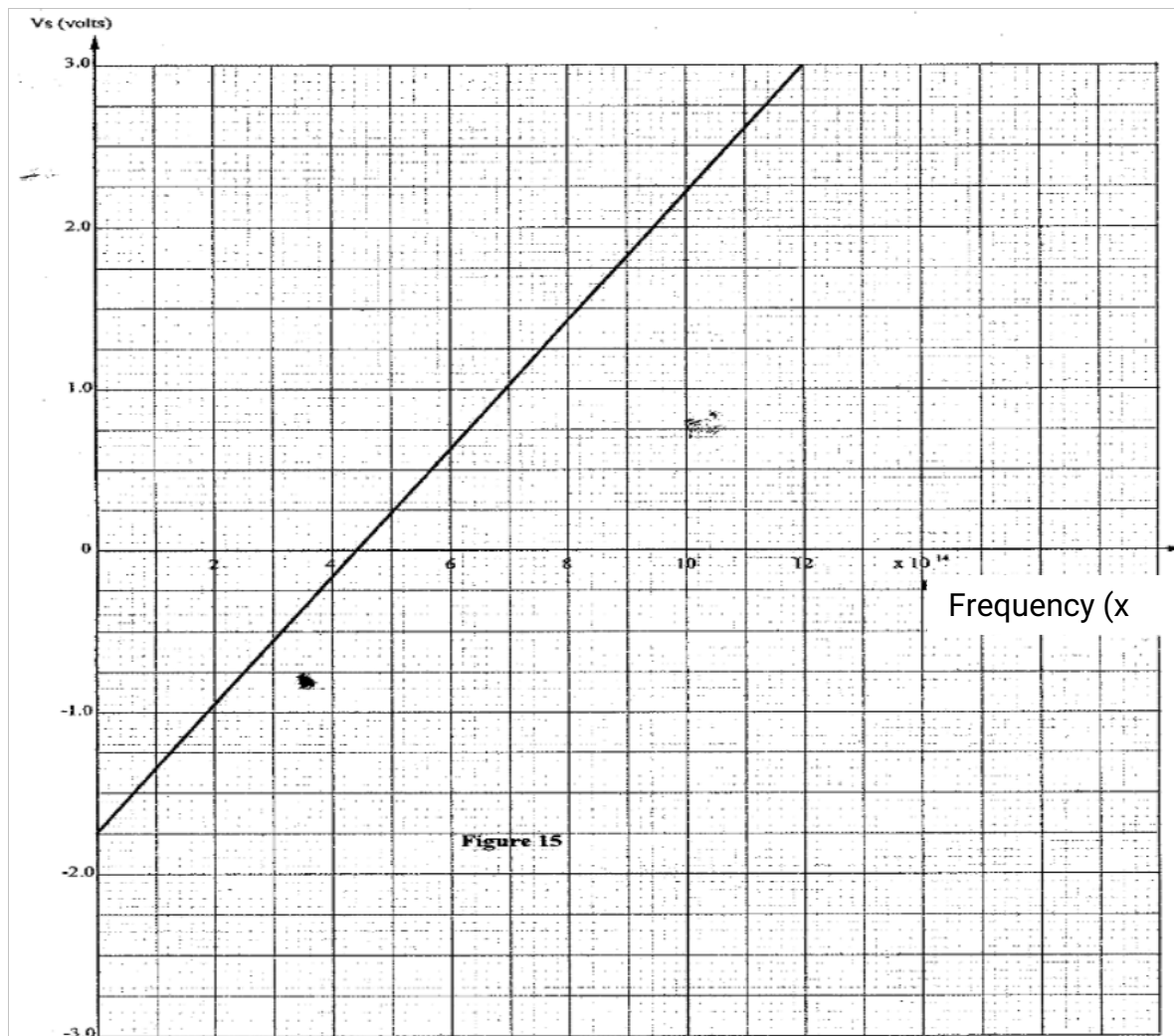

(i) What is meant by stopping potential?

(1mk)

(ii) Given that the stopping potential  $V_s$  is related to the frequency by the equation.

$$V_s = \frac{h}{e}f - \frac{\omega_0}{e} \text{ Where } e \text{ is the charge of an electron, } (e = 1.6 \times 10^{-19}\text{C})$$

Determine from the graph:

(I) plank's constant,  $h$ ;

(4mks)

(II) the work function  $\omega_0$  for the metal in electron volts (eV).

(4mks)

**K.C.S.E 2011  
PHYSICS PAPER 232/2  
QUESTIONS**

**Section (25 marks )  
Answer all the questions provided in this section**

1. **Figure 1**, shows an object placed in front of a plane mirror .



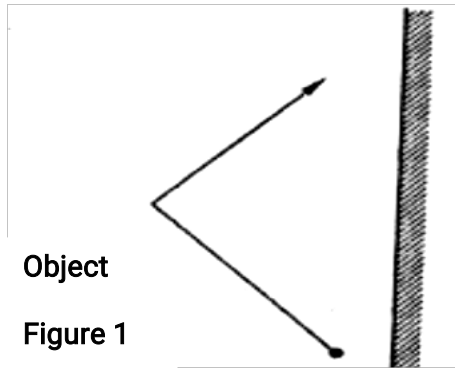

Sketch the image of the object as seen in the mirror.

2. **Figure 2**, shows two identical pith balls A and B suspended with insulated threads. They are separated by an insulator X. A is positively charged while B is negatively charged, The quantity of charge on A is three the quantity of charge on B.

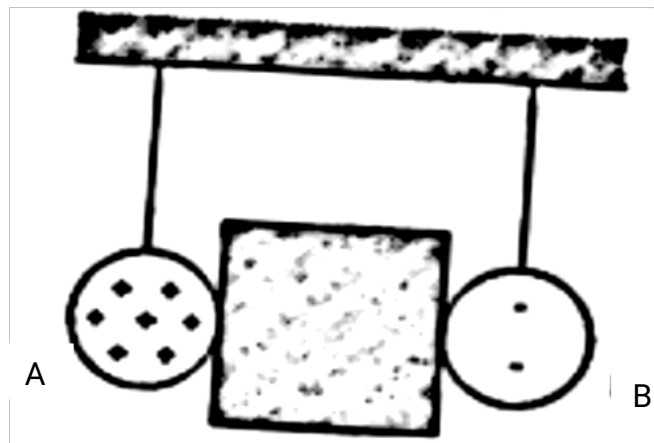

**Figure 2.**

Sketch on the space beside the figure the final position of the pithballs after the insulator is removed.  
(1 mk)

3. **Figure 3**, shows a voltmeter connected across two charged parallel plates.

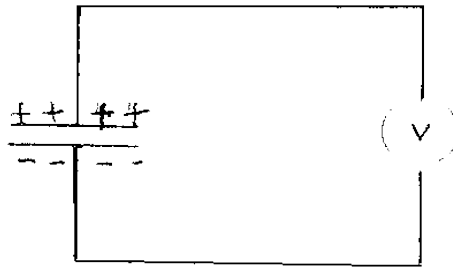

- PARALLEL PLATES  
- Parallel plates  
- Figure 3

When a thin sheet of mica is inserted between the planes, the voltmeter reading is observed to reduce. explain (his observation. (3 mks)

**Figure 4**, shows the cross-section of a dry cell . Use the information on the figure to answer questions 4 and 5.

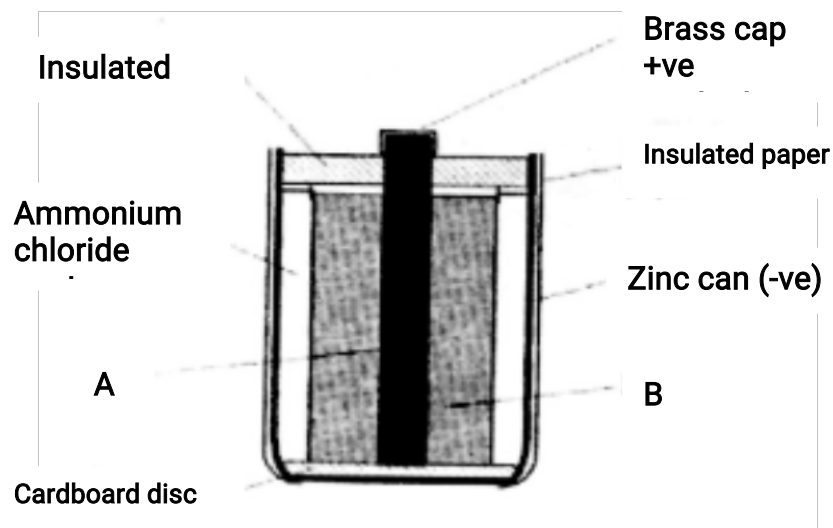

4. Name the parts labeled A and B. (2 mks)

5. State the use of the manganese (IV) oxide in the cell. (1 mk)

6. One method of producing a weak magnet is to hold a steel rod in the North South direction and then hammer it continuously for some time. Using the domain theory of magnetism explain how this method work (2 mks)

**Figure 5**, shows a motor connected to a magnetic switch called a relay operated by an ordinary switch  $S_1$ . Use the information in the figure to answer questions 7 and 8.

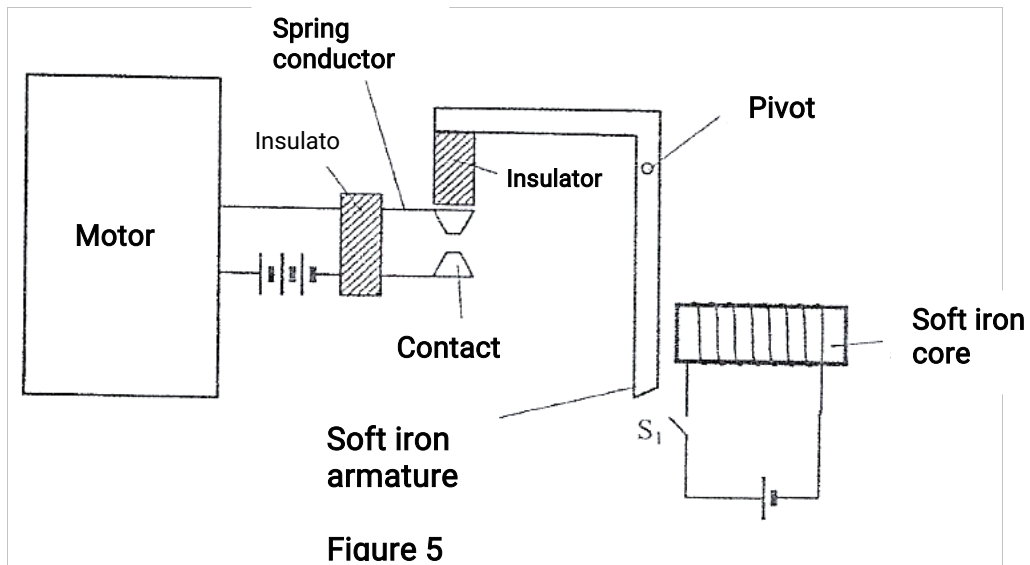

**Figure 5**

7. Explain how the relay switches on the motor when  $S_1$  is closed. (3 mks)
8. State with a reason the effect on the motor, if the iron core is replaced with a steel core and switch  $S_1$  is put on and then off. (2 mks)
9. **Figure 6**, shows standing waves on a string, It is drawn to a scale of 1:5

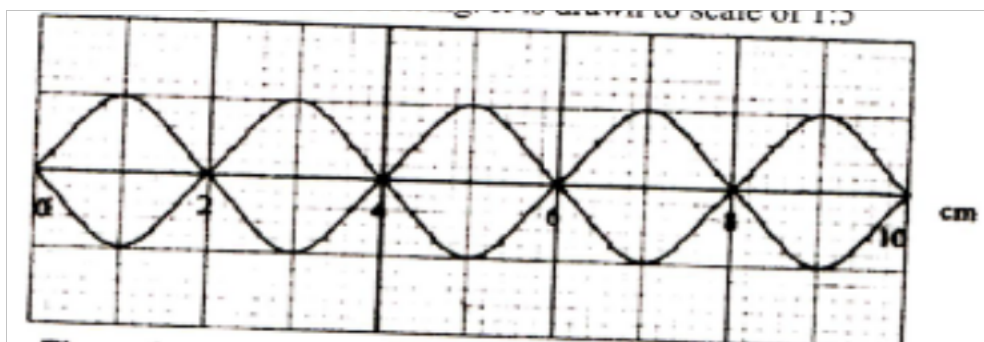

- a) Indicate on the diagram the wave length of the standing wave. (1mk)
- b) Determine the wavelength of the wave. (1mk)

10. **Figure 7**, shows two rays of light incident normally on face PQ of a glass prism, whose critical angle is  $42^\circ$ .

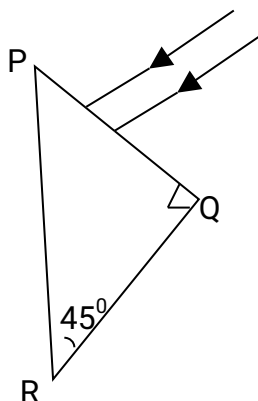

Complete the diagram to show the paths of the two rays as they pass through the prism.

(3 mks)

11. A  $4\Omega$  resistor is connected in series to a battery of e.m.f 6V and negligible internal resistance.

Determine the power dissipated by the resistor.

(2 mks)

12. Table 1 shows radiations and their respective frequencies.

Type of radiation	Yellow light	Gamma rays	Radio waves	Micro waves
Frequency (Hz)	$1 \times 10^{15}$	$1 \times 10^{22}$	$1 \times 10^6$	$1 \times 10^{11}$

Table 1

Arrange the radiations in the order of increasing energy.

(1 mk)

13. State the reason why electrical power is transmitted over long distances at very high voltages.

(1 mk)

14. **State** the meaning of the term "threshold frequency" as used in photoelectric emission.

(1 mk)



**SECTION B (55 marks)**

**Answer all the questions in this section in the spaces provided.**

15. a) Figure 8, shows graph of potential difference  $V$  (volts) against a current (ampere) for a certain device.

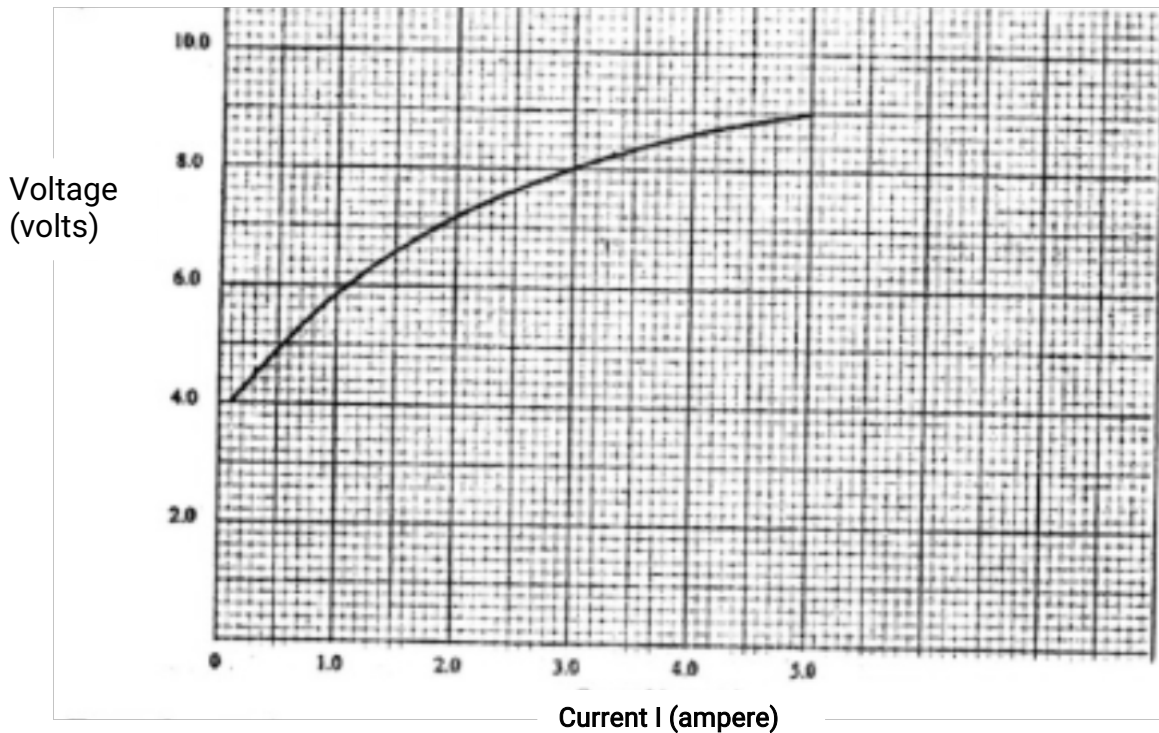

From the graph:

- (i) State with a reason whether or not the device obeys ohms law  
(2 mks)

- (ii) Determine the resistance of the device at

- (iii) From the results obtained in (ii) state how the resistance of (the device varies as the current increases.  
(1 mk)

- (iv) State the cause of this variation in resistance.  
(1mk)

- (b) Three identical dry cells each of e.m.f. 1.6V are connected in series to a resistor of  $11.4\Omega$ . A current of 0.32A flows in the circuit .

Determine:

- (i) the total e.m.f. of the cells; (1 mk)

- (ii) the internal resistance of each cell; .  
(3 mk)

16. (a) State the meaning of the term "principal focus" as applied in lenses.  
(1 mk)

(b) You are provided with the following apparatus to determine the focal length of a lens:

- a biconvex lens and lens holder.
- a lit candle.
- a white screen.
- a metre rule

(i) Draw a diagram to show how you would arrange the above apparatus to determine the focal length of the lens  
(1mk)

(ii) Describe the procedure you would follow. (1mk)

(iii) State two measurements that you would take .  
(2 mks)

(iv) Explain how the measurements in (iii) would be used to determine (the focal length .

(c) An object is placed 30cm in front of a concave lens of focal length 20cm. Determine the magnification of the image produced.  
(4 mks)

17. a) State what is meant by "electromagnetic induction" (1 mk)

b) Figure 9, shows a simple electric generator

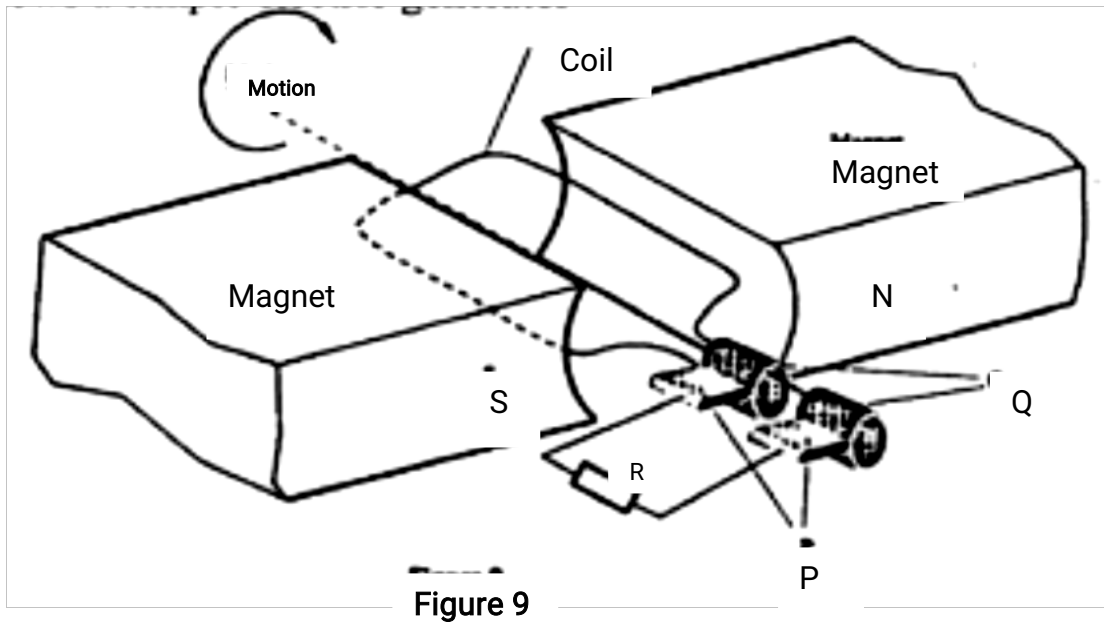

Figure 9

- i) Name the parts labeled P and Q. (2 mks)
- ii) Sketch on the axes provided, a graph to show how the magnitude of the potential difference across R, changes with the time (1 mk)
- iii) State two ways in which the potential difference produced by such a generator can be increased.
- (c) In a transformer, the ratio of primary turns to the secondary turns is 1: 10. A current of 500mA flows through a 200Ω resistor in the secondary circuit. Assuming that the transformer is 100% efficient, determine:
- (i) the secondary voltage; (1 mk)
- (ii) the primary voltage: (2 mks)
- (iii) the primary current. (2 mks)

18. (a) State two differences between cathode rays and electromagnetic radiations. (2mks)

(b) Figure 10, shows the main features of a cathode ray oscilloscope (CRO).



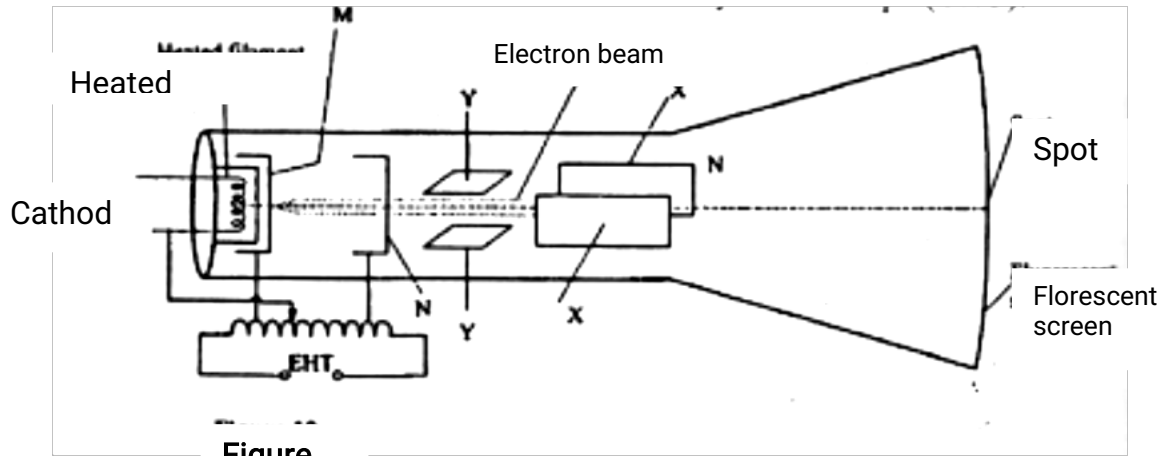

Figure

- (i) Name the parts labelled M and N  
(2mks)
- (ii) Explain how electrons are produced in the tube.  
(2mks)
- (iii) When using the CRO to display waveforms of voltages, state where the following should be connected:
- I) the voltage to be displayed on the screen;  
(1mks)
  - II) The time base voltage  
(1mks)
- (iv) State why the tube is highly evacuated.  
(1mks)
- (c) **Figure 11**, shows the waveform of a voltage displayed on the screen of a CRO. The Y-gain calibration was 5V per cm.

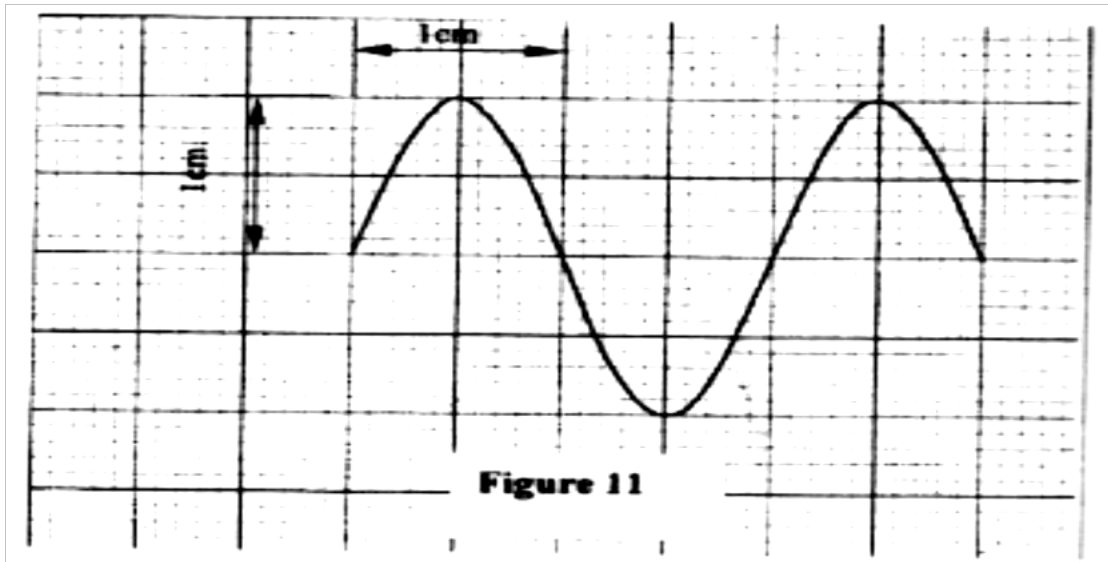

(i) Determine the peak-to-peak voltage of the Y - input .  
(1mk)

(ii) Sketch on the same figure appearance of the waveform after the voltage of the input signal is halved and its frequency is doubled.

(2 mks)

19. a) When a radiation was released into a diffusion cloud chamber, short thick tracks were observed. State with a reason, the type of radiation that was detected. (2 mks)

(b) The half-life of an element X is 3.83 days. A sample of this element is found to have an activity rate of  $1.6 \times 10^1$  disintegrations per second at a particular time. Determine its activity rate after 19.15 days. (2 mks)

(c) State what is meant by an extrinsic semiconductor.  
(1 mk)

(d) Figure 12, shows n depletion layer in an unbiased p-n junction .

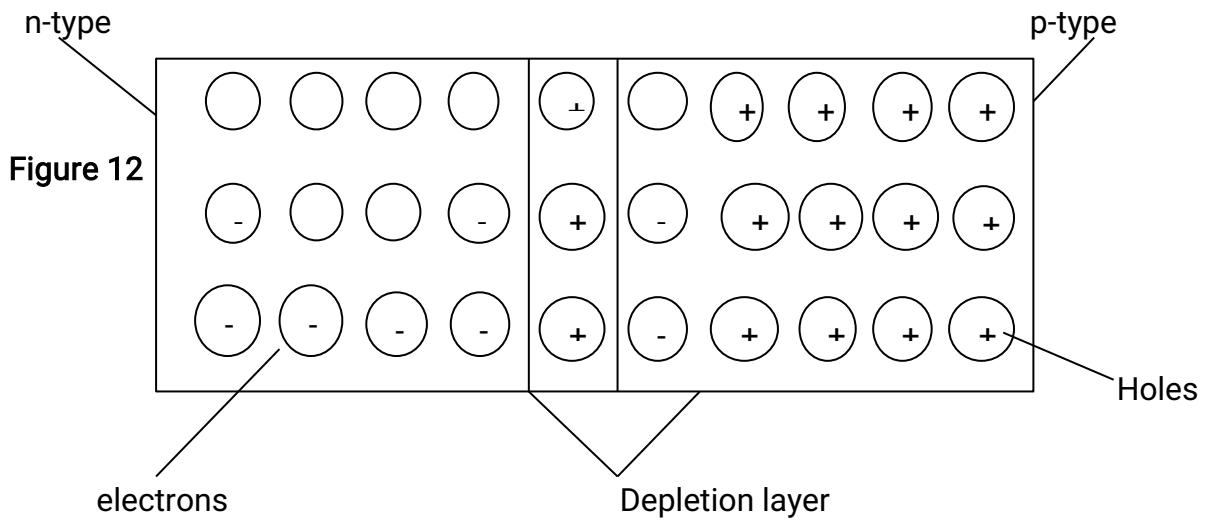

State how a battery can be used to make the depletion layer narrower.  
( 1 mk)

(e) Figure 13, shows an incomplete circuit of a full wave rectifier.

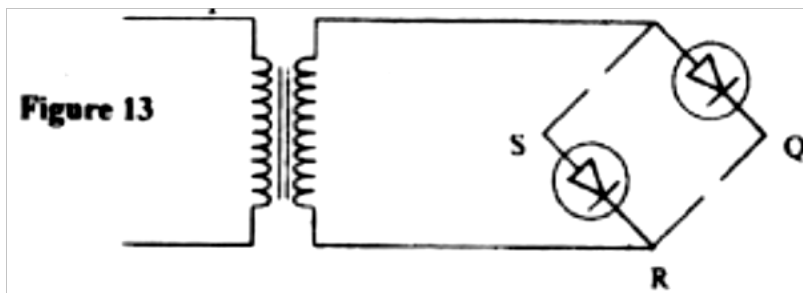

(i) Draw in the figure two more diodes to complete the circuit.  
(2 mks)

(ii) Show on the figure the points across which the output of the rectifier should be obtained.

(1 mk)

**K.C.S.E 2012**  
**PHYSICS PAPER 232/2**  
**QUESTIONS**

1. **Figure 1**, show a plane mirror XY placed equidistant from two parallel lines AB and PT.

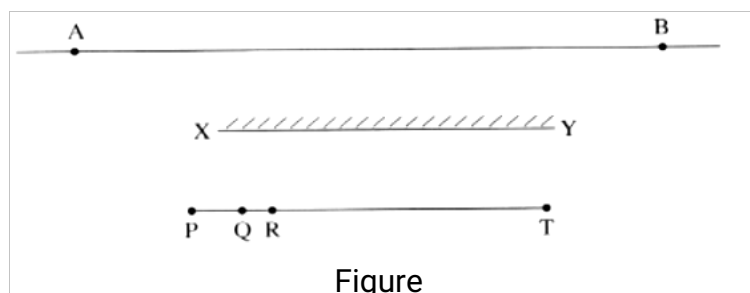

Four students stand at P, Q, R and T in front of the mirror

- a) Indicate the positions of the images of students at Q, R and T on line AB  
 (1 mk)
- b) State which of the tree images are visible to the student standing at P.  
 (1 mk)
- c) Using rays indicate on the figure, how (b) above is possible  
 (1 mk)

2. **Figure 2**. Shows two mirrors PQ and QR inclined at an angle of  $110^\circ$ . A ray of light is incident on mirror PQ at an angle of  $60^\circ$ .

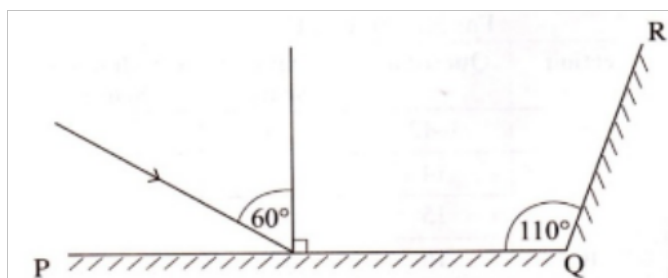

Complete the diagram to determine the angle of reflection of the ray in the mirror QR.

3. **Figure 3**, shows four identical light bulbs connected to a 15 volt battery whose internal resistance is negligible.

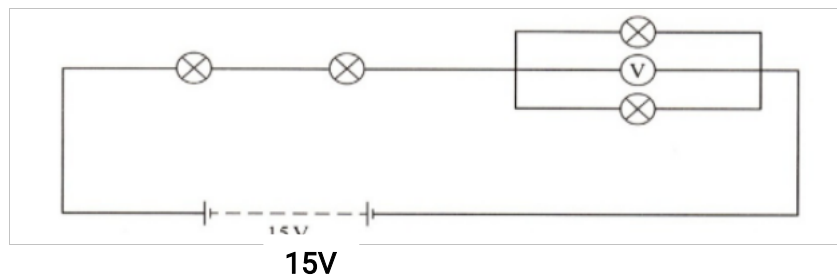

Determine the reading of the voltmeter V.

(2 mks)

4. **Figure 4**, Shows a negative point charge placed near a positively charged rod. Draw on the diagram, the resulting electric field pattern (2 mks)

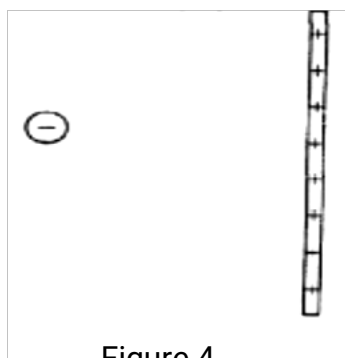

5. Figure 5, shows an object O at the bottom of a beaker full of a liquid. An observer above the beaker sees its image at point X inside the liquid. Determine the refractive index of the liquid (3 mks)

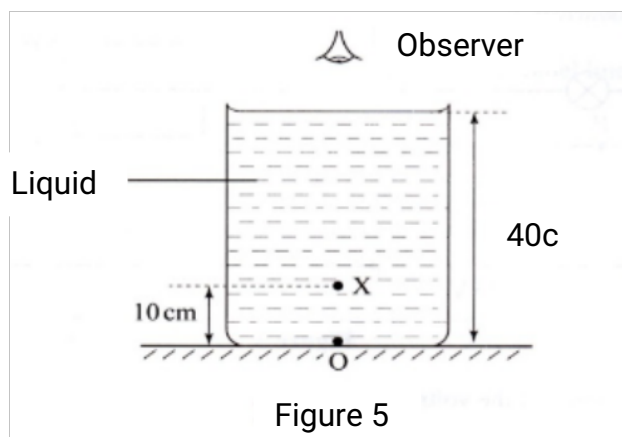

6. **Figure 6**, shows a narrow beam of radiation from a radioactive source, incident to a postcard. The emergent radiation passes through a magnetic field which is perpendicular to the plane of the paper, and into the paper.

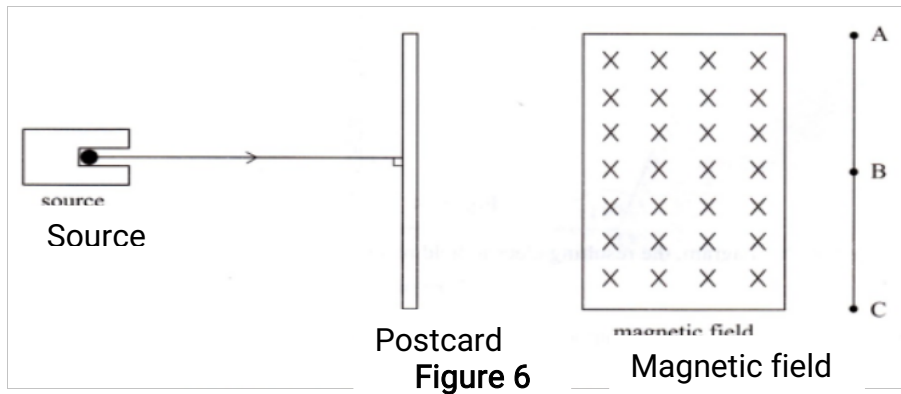

A detector moved along line AC detects radiations only at points B and C. state the two types of radiations detected (1 mk)

7. **Figure 7**, shows two similar coils P and Q around the end L and M of a piece of soft iron. A steady current passes through the coils. State the polarity of the resulting magnet at end L (1 mk)

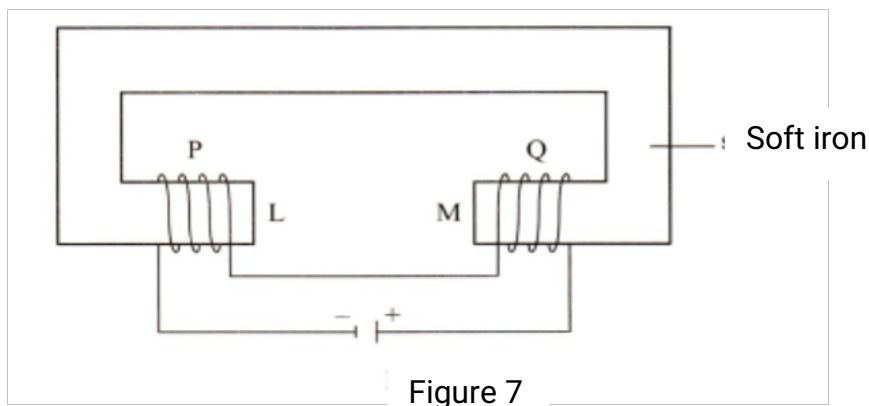

8. Light from a lamp falls on the cap of a negatively charged electroscope. It is observed that the divergence of the leaf decreases. Explain the observation (2 mks)

9. **Figure 8**, shows an object O placed in front of a diverging lens whose principal focus is F. On the figure, draw a ray diagram to locate the image formed (3 mks)

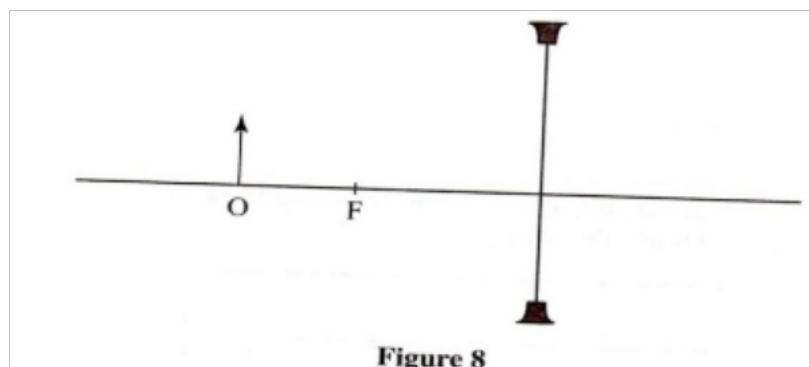

10. Figure 9, shows the cross section of an optical fibre made of two types of glass, A and B. The refractive index of B is lower than that of A.

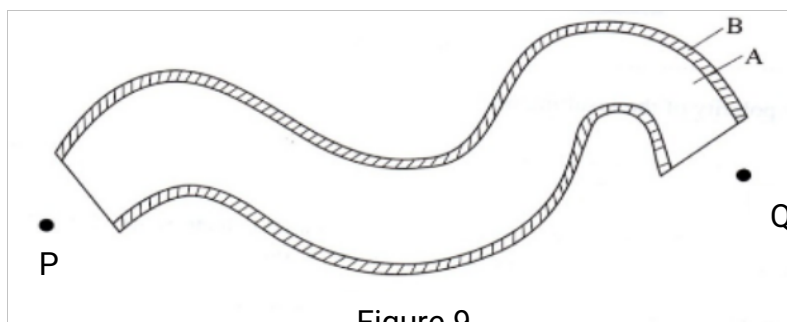

A ray of light enters the optical fibre at P and emerges from Q

- i. Sketch the path of the ray through the fibre  
(1 mk)
- ii. State the reason why light travels through the fibre as in (i) above

(1 mk)

11. **Figure 10**, shows the cross section of a conductor held between two magnets and carrying a current out of the paper. Indicate with an arrow on the diagram the direction in which the conductor will move when it is released.  
(1 mk)

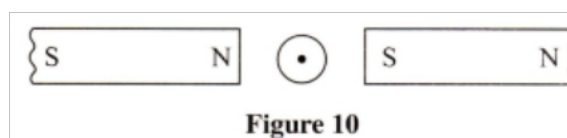

12. State why alternating current (a.c) is used for transmitting electricity over long distances  
(1 mk)

13. Figure 11, shows an alternating current (a.c) connected across a diode D and a resistor R.

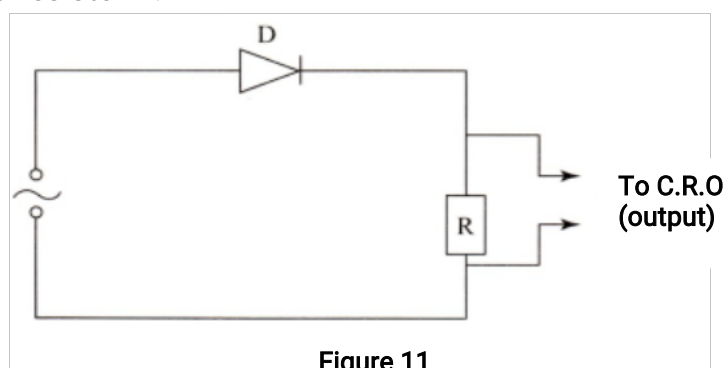

On the axes provided sketch the output as observed in the C.R.O connected across R.

(1mk)

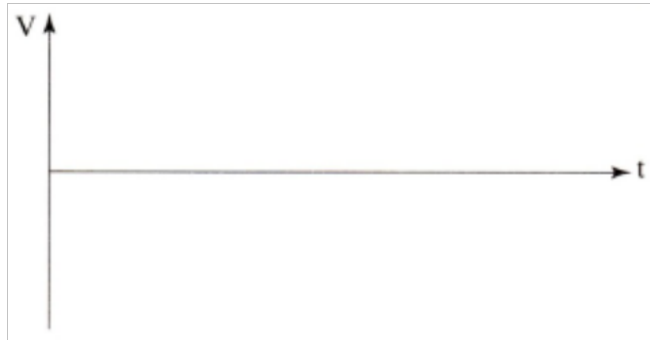

14. a) **Figure 12**, shows a displacement –time graph for a progressive wave.  
Displacement (cm)

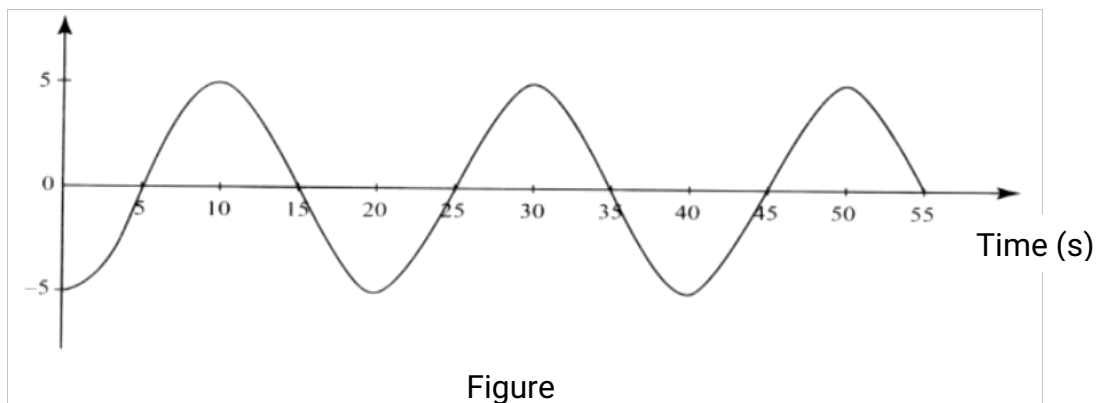

Figure 12

- i. State the amplitude of the wave  
(1 mk)
  - ii. Determine the frequency of the wave  
(4 mks)
  - iii. Given that the velocity of the wave is  $20^{\text{ms}^{-1}}$ , determine its wavelength  
(3 mks)
- b) **Figure 13** shows two identical dippers A and B vibrating in water in phase with each other. The dippers have the same constant frequency and amplitude. The waves produced are observed along line MN;



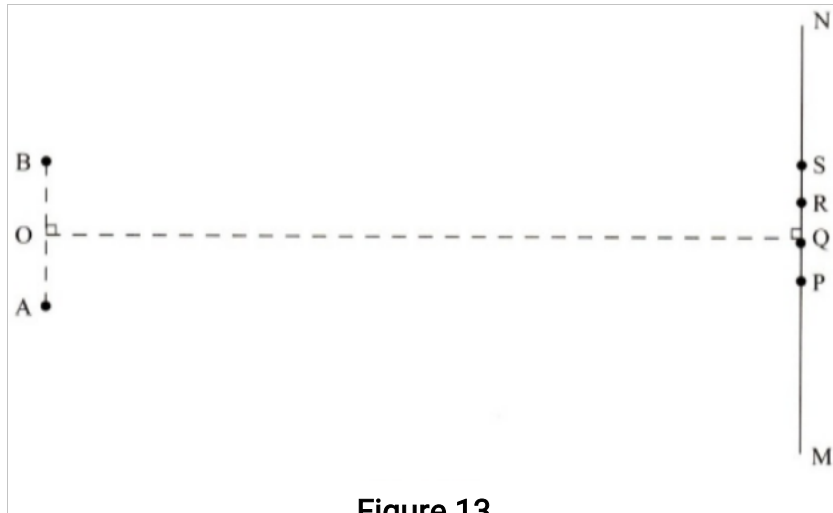

Figure 13

It is observed that the amplitudes are maximum at points Q and S, and minimum at points P and Q.

- i. Explain why the amplitude is maximum at Q.  
(2 mks)
- ii. State why the amplitude is minimum at R. (1 mk)
- iii. State what would happen if the two dippers had different frequencies  
(1 mk)

15. Figure 14, Shows a circuit in which a battery, a switch, a bulb, a resistor P, a variable resistor Q, a voltmeter V and two ammeters  $A_1$  and  $A_2$  of negligible resistance are connected.  
P has a resistance of  $10\Omega$ . When the switch is closed  $A_1$  reads 0.10 A and the voltmeter reads 1.5V.

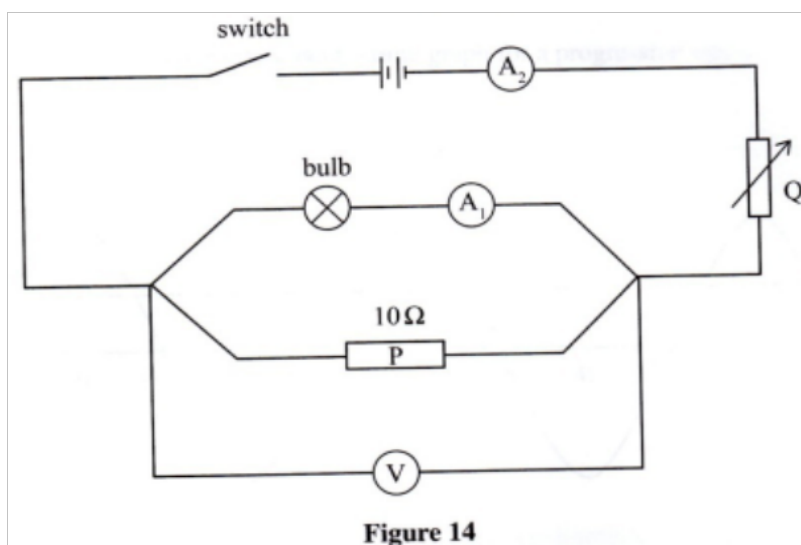

Figure 14

- a) Determine

- i. The current passing through P;  
(3 mks)
  - ii. The resistance of the bulb (2 mks)
- b) The variable resistor Q is now adjusted so that a large current flows through  $A_2$ .
- i. State how this will affect the resistance of the bulb.  
(1 mk)
  - ii. Explain your answer in (b) (i) (2 mks)
- c) A house has one 100 W bulb, two 60 W bulbs and one 30W bulb.  
Determine the cost of having all the bulbs switched on for 70 hours,  
given that the cost of electricity is 40 cents per kilowatt hour.  
(3mks)

16.

- (a) Figure 15, shows two coils A and B placed close to each other. A is connected to a steady D.C. supply and a switch, B is connected to a sensitive galvanometer.

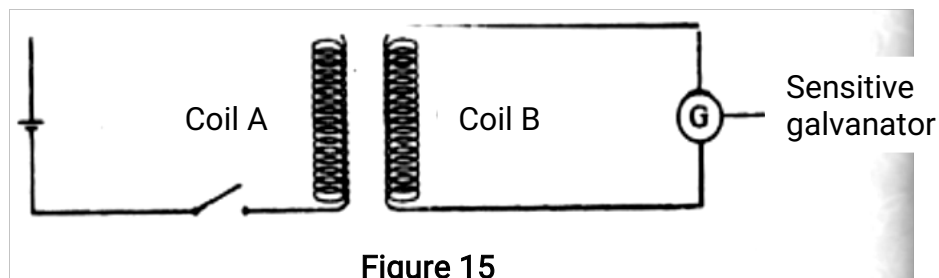

Figure 15

- i. The switch is now closed. State the observation made on the galvanometer (2mks)
  - ii. Explain what would be observe dif the switch is then opened (2mks)
- b) The primary coil of a transformer has 1000 turns and the secondary coil has 200 turns .The primary coil is connected to a 240V a.c.. mains, supply
- i. Explain how an e.m.f is induced in the secondary coil.  
(2mks)
  - ii. Determine the secondary voltage  
(2mks)
  - iii. Determine the efficiency of the transformer given that the current in the primary coil is 0.20A and in the secondary coil it is 0.80 A.  
(3mks)

17.

a) Figure 16, shows a graph of magnification against object distance, for an object placed in front of a lens of a focal length 20cm.

Using the graph

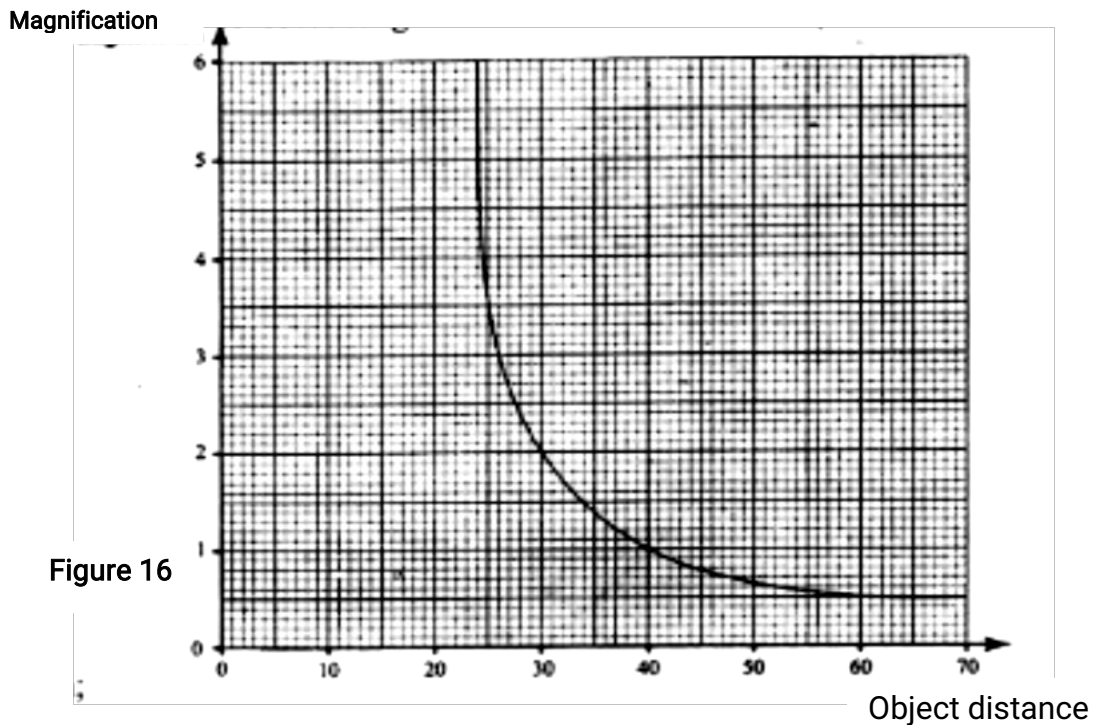

- i. State the effect on the size of the image when the object distance is increased from 25cm  
(1mk)
- ii. Determine the distance between the object and the lens when the image is the same size as the object  
(2mks)
- iii. Determine the image distance when the object distance is 25cm  
(3mks)

b) **Figure 17** shows an object O placed in front of a converging mirror of focal length 15 cm.

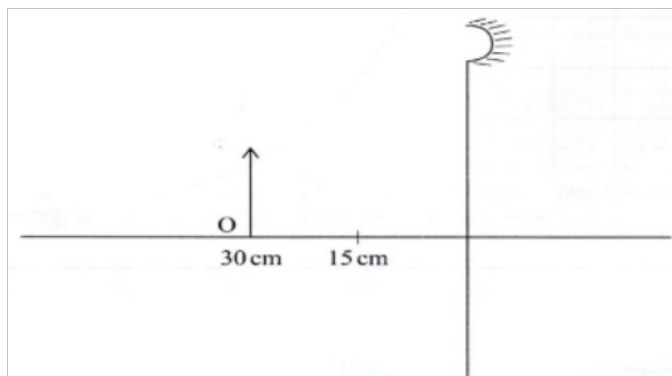

Draw on the figure a ray diagram to locate the image formed  
(3 mks)

c) State why parabolic reflectors are used in car headlights.  
(1 mk)

18. Figure 18 shows the parts of an x-ray tube.

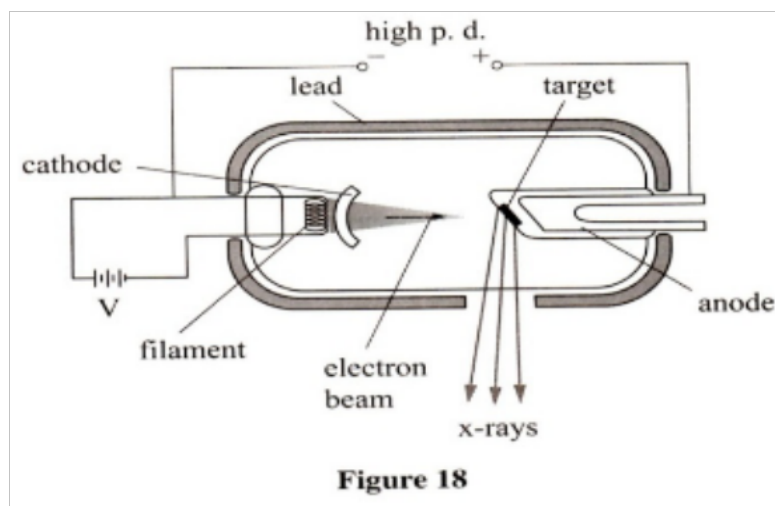

- a) Explain why;
- i). A potential difference is applied to the filament  
(2 mks)
  - ii.) A high potential difference is applied between the cathode and the anode  
(2 mks)
  - iii) Most of the tube is surrounded by lead.  
(1 mk)
- b) State how the resulting x-rays are affected by increasing the potential difference between the anode and the cathode  
(1 mk)
- c) Light of frequency  $7.5 \times 10^4$  Hz strikes a metal surface whose work function is  $4.0 \times 10^{-19}$  J. Determine the kinetic energy of the emitted photoelectrons.  
(take planks constant  $h=6.63 \times 10^{-34}$  Js)  
(4 mks)

**K.C.S.E 2013**  
**PHYSICS PAPER 232/2**  
**QUESTIONS**

**SECTION A (25 marks)**  
**Answer all the questions in this section.**

1. State the reasons why when a ray of light strikes a mirror at  $90^\circ$ , the reflected ray travels along the same path as the incident ray.  
(1mk)
2. Explain why the image formed in a pin hole camera gets blurred when the hole is enlarged. (2mks)
3. State the reason why the magnetic field strength of a magnet is greatest at the poles.  
(1mk)
4. **Figure 1** shows a cell of e.m.f. 2v connected in series with a resistor R and a switch S. Voltmeters  $V_1$  and  $V_2$  are connected across the cell and the resistor respectively.

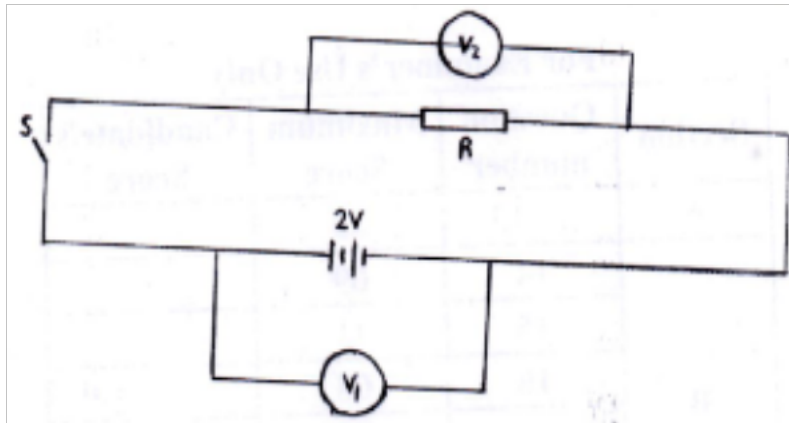

(a) State the reading of  $V_1$  with S open

(1mk)

(b) With S closed,  $V_1$  reads 1.6 V. State the reading of  $V_2$

(1 mk)

5. **Figure 2** shows the image of an object formed by reflection in a converging mirror. C is the centre of curvature of the mirror.

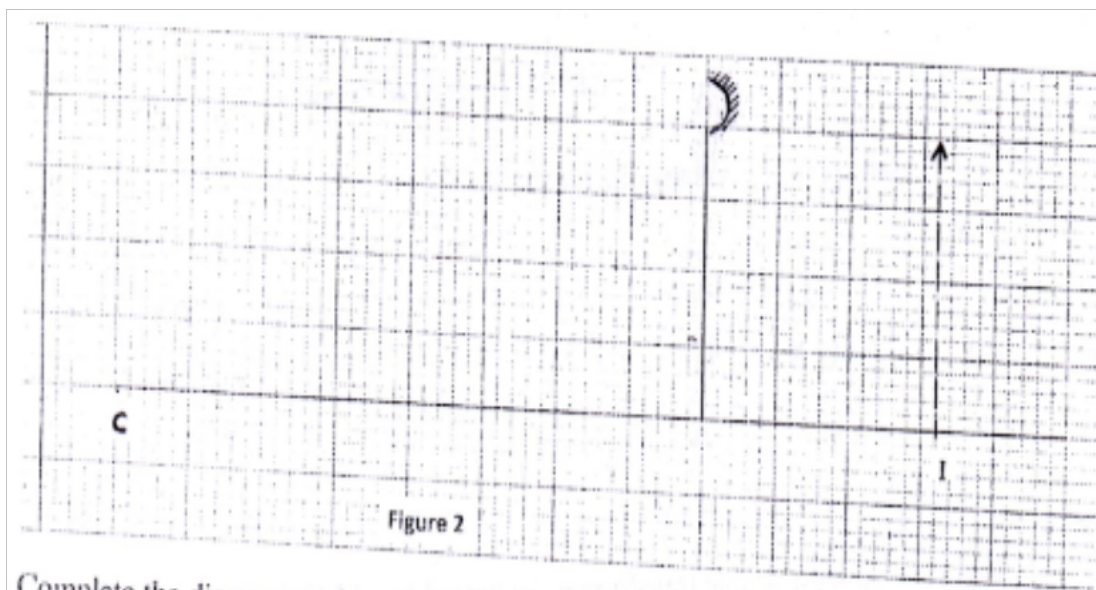

Complete the diagram to show:

- (a) How incident rays are reflected to form the image:

(2mks)

- (b) The object position

(1mk)

6. **Figure 3** shows a ray of light passing into a glass prism ABC

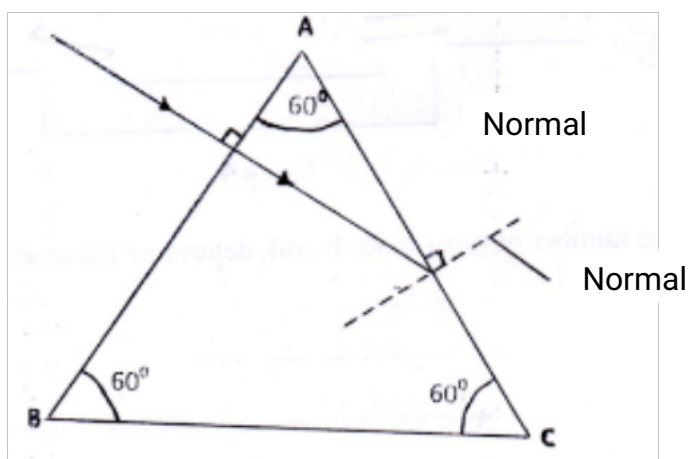

**Figure 3**

Sketch the path of the ray as it travels from face AC. (*critical angle for glass is  $42^\circ$* )

7. The equation below represents a nuclear reaction in which two deuterium nuclei fuse to form Helium and X

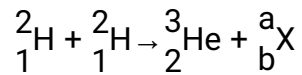

- (a) Determine the values of a and b (1mk)
- (b) Identify X (1mk)
8. Figure 4 shows a simple transformer connected to a 12V a.c, source and an a.c, voltmeter.

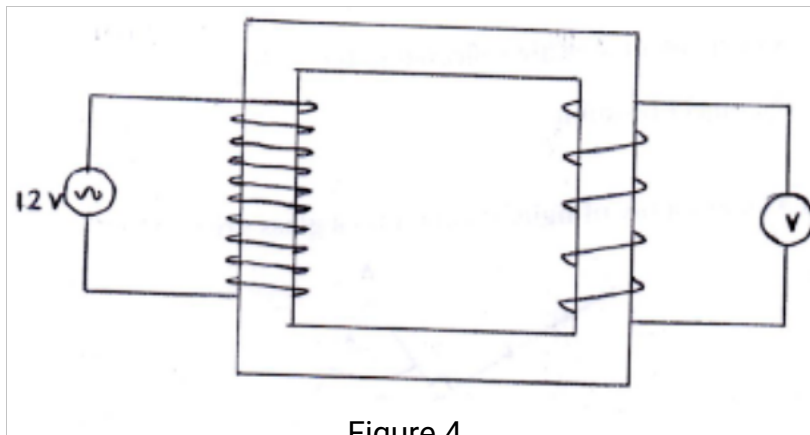
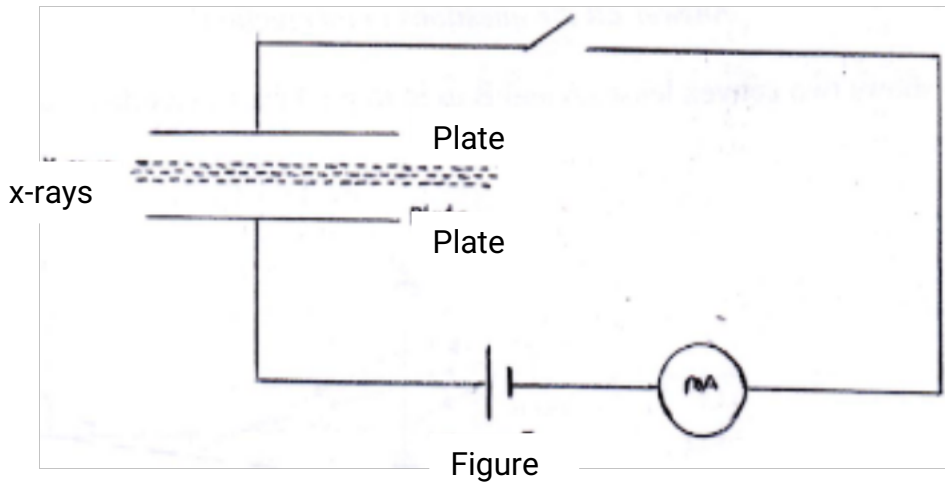

Figure 4

By counting the number of turns in each coil, determine the reading on the voltmeter (3mks)

9. In domestic wiring systems lamps in the lighting circuit are required to be in parallel and not in series. State two reasons for this requirement. (2mks)

10. **Figure 5** shows a narrow beam of x-rays passing between two metal plates in air. The plates are connected in series with a switch, a cell and a milliammeter.



Figure

It is observed that when the switch is closed a current flows in the milliammeter. Explain this observation.

(2mks)

11. Explain the fact that radiant heat from the sun penetrates a glass sheet while radiant heat from burning wood is cut off by the glass sheet.

(2mks)

12. A photon of ultraviolet light having energy  $E$  falls on a photoemissive surface whose work function is  $T$ . Write an expression for the maximum kinetic energy of the resulting photoelectron in terms of  $E$  and  $T$ . (1mk)

13. When a germanium crystal is doped with arsenic, it becomes an N-type semiconductor. Explain how this change occurs.

(2mks)

(Number of electrons in the outermost shell for germanium = 4, Arsenic = 5).

### SECTION B (55 Mks)

*Answer all the questions in this section.*

14. Figure 6 shows two convex lenses A and B used to produce a magnified virtual image of an object.



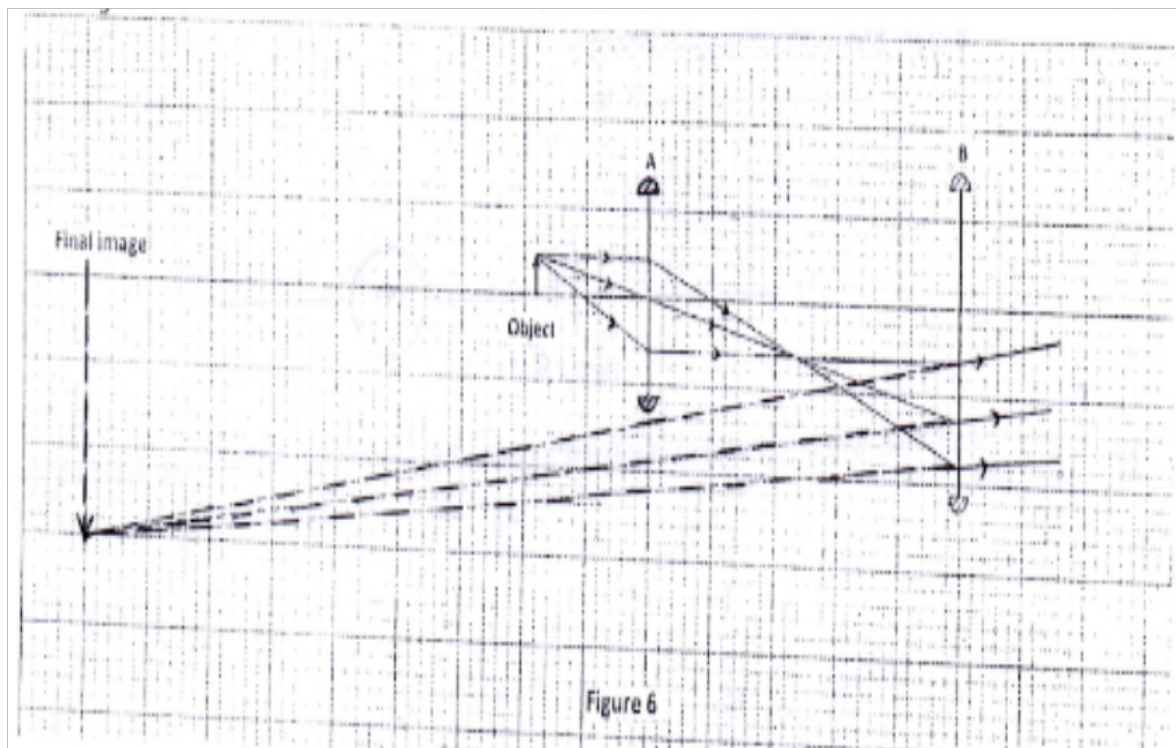

(a) Determine the focal length of lens A. (*Take 1 unit to represent 10cm*)  
(1mk)

(b) State the function of:

(i) Lens A

(1mk)

(ii) Lens B

(1mk)

(c) State how the functions in (b) are achieved by:

(i) Lens A

(1mk)

(ii) Lens B

(1mk)

(d) Determine the magnification produced by:

(i) Lens A

(2mks)

(ii) The whole system

(2mks)

15. (a) Explain how a positively charged electroscope gets discharged when the cap is touched with a finger.

(2 mks)

(b) **Figure 7** shows capacitors **A** and **B** connected in series with a battery

of e.m.f. 4V

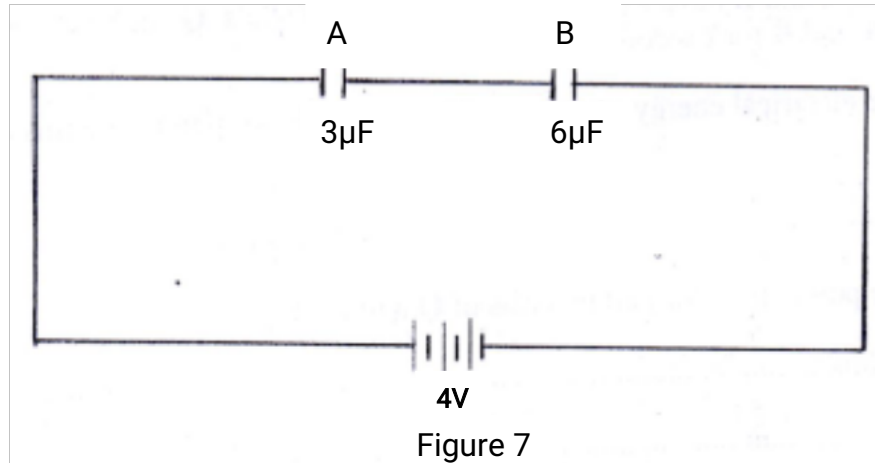

Figure 7

Determine:

(i) The effective capacitance of the circuit.

(3mks)

(ii) The quantity of charge in capacitor A

(3 mks)

(iii) The quantity of charge in capacitor B

(3 mks)

(c) Figure 8 shows an isolated negative point charge Q



On the figure, sketch the electric field pattern around the charge.

(2 mks)

16. (a) Two points **A** and **b** have a potential difference of **V** volts. **Q** coulombs of charge flow between **A** and **B** for **t** seconds.

Determine:

(i) The electrical energy transformed between the two points in terms of **Q**.

(1 mk)

(ii) The power transformed in terms of **Q** and **t**.

(1 mk)

(iii) Show the power transformed is given by  $P = IV$

(2 mks)

(b) The lighting circuit in a house has 20 lamps each rated 60W, 240V.

Determine

whether a fuse rated 4 A can be used in the circuit when all the lamps are put on.  
(4mks)

17. (a) **Figure 9** shows a cathode ray tube in which a beam of electrons is cast on the screen.

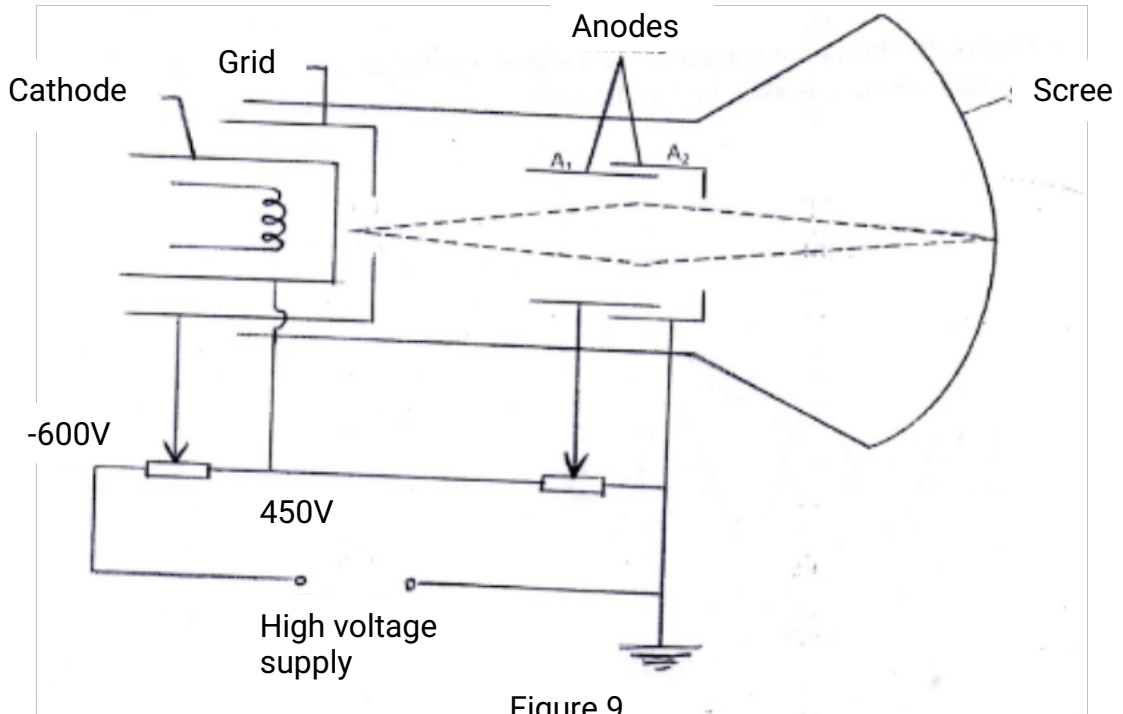
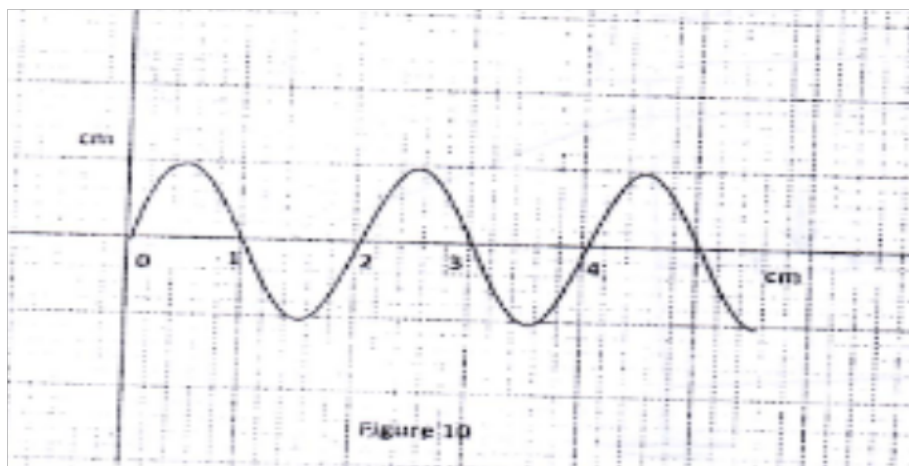

Figure 9

- (i) State how the electrons are produced in the tube.  
(1mk)
- (ii) State how the electron beam is detected  
(1mk)
- (iii) State the reason for having a variable potential difference (p.d.) at the:
- (I) Grid; (1mk)
  - (II) Anodes (1mk)

- (c) **Figure 10** shows the waveform of a signal applied at the y-plates of an oscilloscope whose time-base is switched to the scale of 2 milliseconds per centimeter.



Determine:

- (i) The period of the signal;  
(2mks)
- (ii) The frequency of the signal.

(3mks)

18. (a) **Figure 11** shows plane light waves in air incident on a convex lens whose principal focus is **F**, the waves move past point **G**.

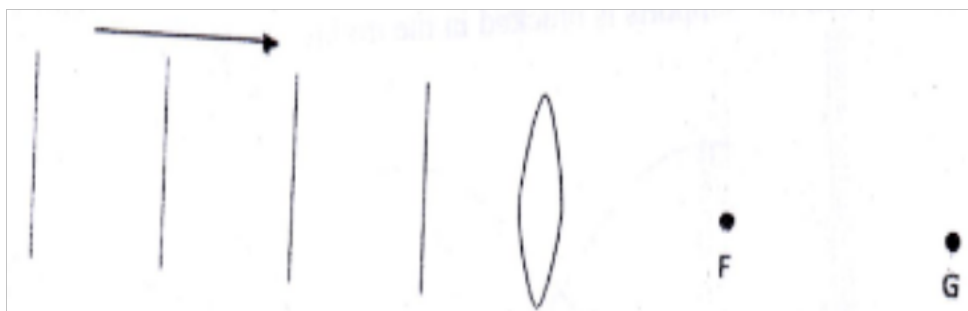

Complete the diagram to show the pattern of the emergent waves between the lens and point **G**.  
(2mks).

- (b) **Figure 12** shows crest of circular water waves spreading from two points **A** and **B** due to a vibrator. **C** and **D** are points on the surface of the water.

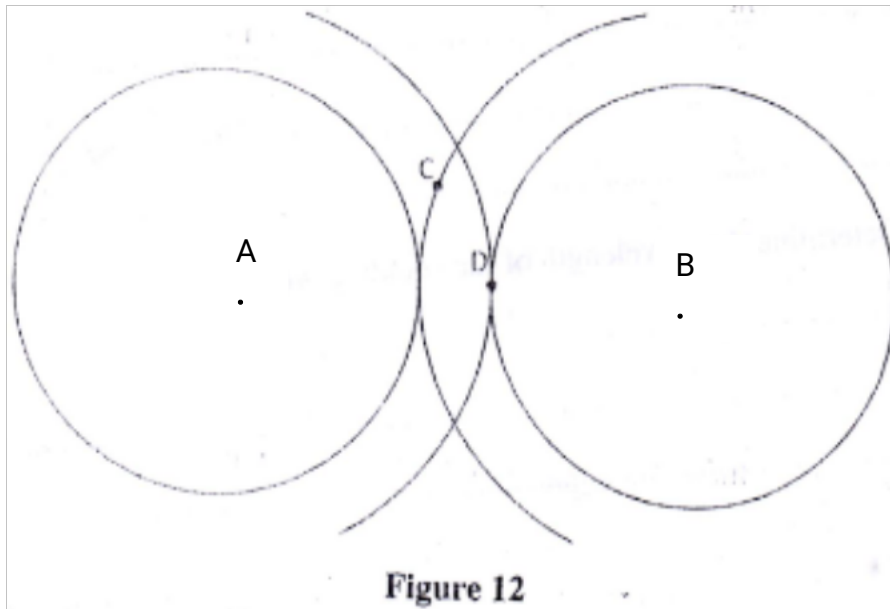

Given that the amplitude of each wave is 5cm. state with a reason the amplitudes of the waves at point:

- (i) C; (2mks)
- (ii) D. (2mks)
- (c) **Figure 13** shows a standing wave formed when a string of length 1.5m stretched between two supports is plucked in the middle.

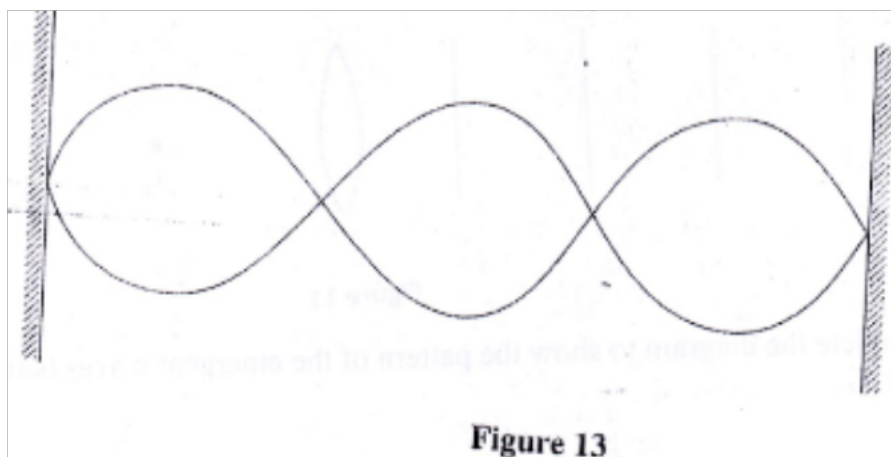

- (i) Explain how the standing wave is formed. (3mks)

(ii) Determine the wavelength of the standing wave.

(1mk)

19. (a) **Figure 14** shows an E shaped steel block being magnetized by a current through two coils in series.

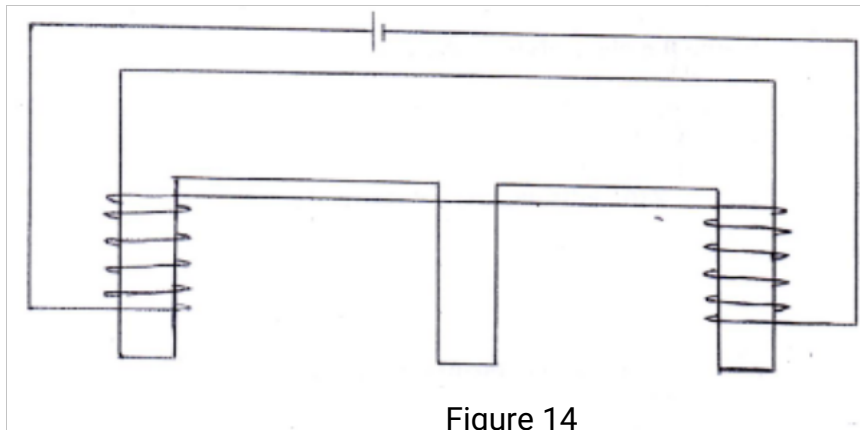

Figure 14

On the figure, indicate

(i) The north and south poles of the resulting magnet

(1mk)

(ii) The complete magnetic field pattern between the poles

(1mk)

(c) **Figure 15** shows the permanent magnet made in part (a) above.

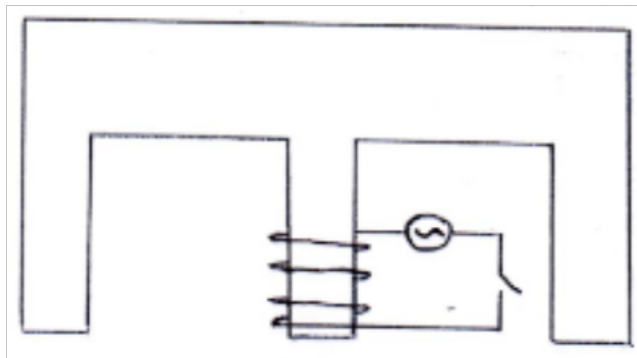

A coil wound loosely on the middle limb is connected in series with a low voltage a.c. and a switch. State and explain the observation made on the coil when the switch is closed

(2 mks)

(c) In a simple cell, the zinc plate gets negatively charged and the copper plate gets positively charged.

(i) Name the electrolyte in the cell

(1mk)

- (ii) Explain how:
- (I) Zinc gets negatively charged. (1 mk)
- (II) Copper gets positively charged (1 mk)
- (iii) State what constitutes the current when a wire is used to connect the zinc plate and the copper plate externally.  
(1mk)

**K.C.S.E 2014**  
**PHYSICS PAPER 232/2**  
**QUESTIONS**

**SECTION A 25 marks**

1. **Figure 1** shows two parallel rays from a distant object passing through a convex lens:

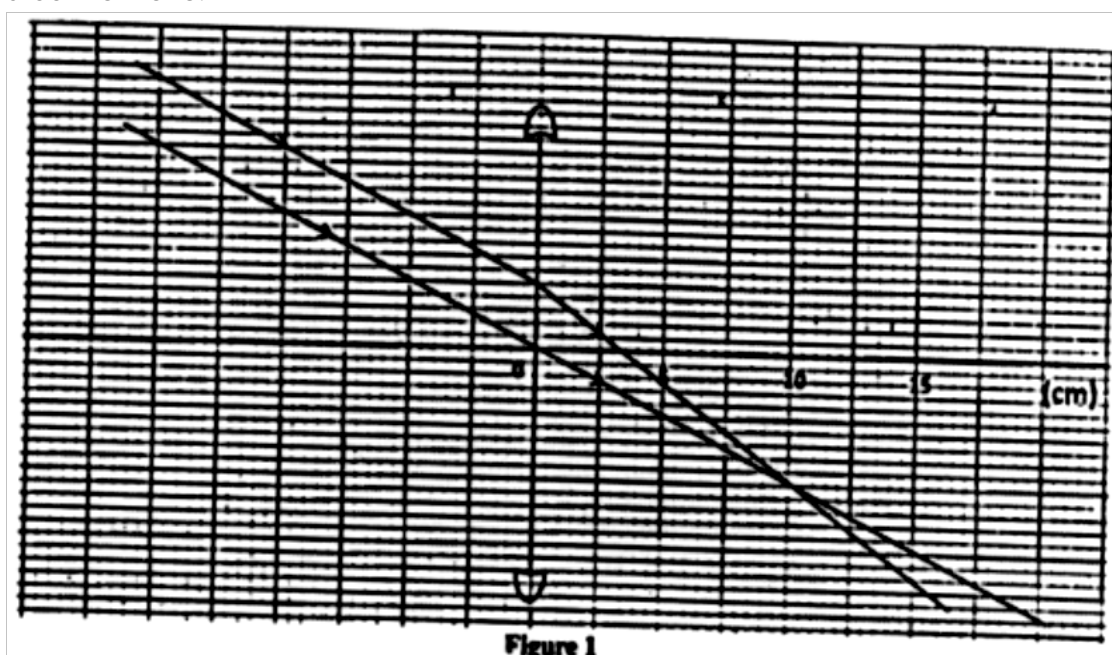

- a) Indicate on the diagram, the position of the principal focus of the lens  
(1 mk)
- b) Determine the focal length of the lens  
(1 mk)
2. State the effect of decreasing the distance between the plates of a parallel plate capacitor on the capacitance. (1 mk)
3. **Figure 2** shows circular waves originating from the principal focus F of a

concave mirror and moving towards the mirror.

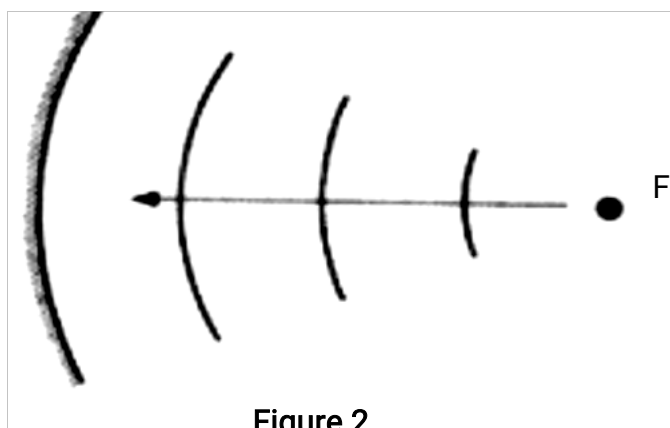

Figure 2

Complete the diagram to show the reflected waves.

(1 mk)

4. The frequency of an electromagnetic wave is  $4.0 \times 10^6$  Hz. determine its wavelength.

(take speed of light as  $3.0 \times 10^8$   $ms^{-1}$ ).

(3 mks)

5. Figure 3 shows a nail on which a wire is to be wound to make an electromagnet.

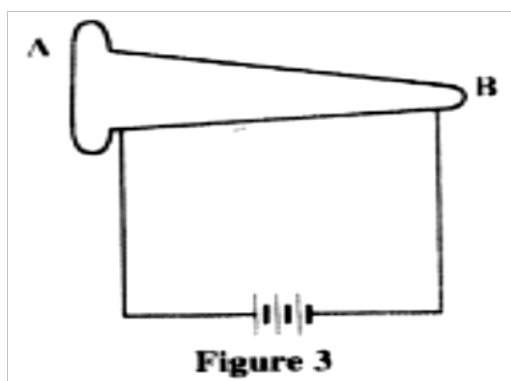

Figure 3

By drawing, show how the wire should be wound around the nail so that end A becomes a north pole and end B a south pole.

6. It is observed that when the cap of an uncharged electroscope is irradiated with light of high frequency, the leaf of the electroscope rises. Explain this observation.

(3mk)

7. Figures 4 shows the magnetic field pattern around two bar magnets placed side by side.



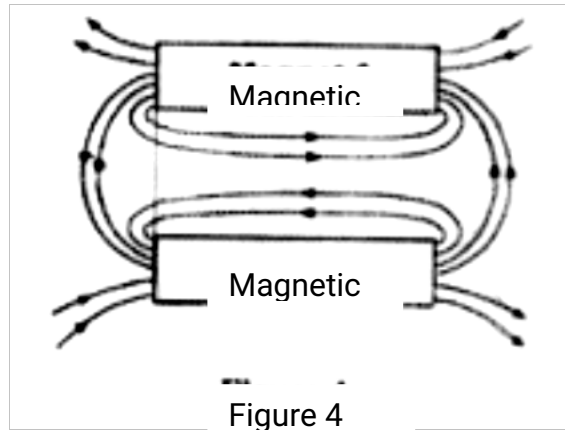

Indicate on the diagram the poles of each magnet.  
(1 mk)

8. **Figure 5** shows a graph of current against voltage for a semiconductor diode.

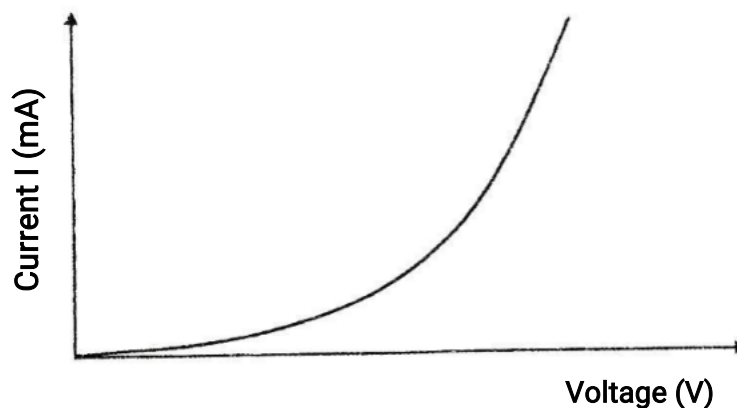

In the space provided, draw a circuit diagram that may be used to obtain values needed to draw the graph in **figure 5**

9. Radium undergoes radioactive decay by emitting an alpha particle to form a daughter nuclide Q as in the reaction:



Determine the values of:

- a) X (1 mk)
- b) Y (1 mk)

10. State two uses of charged gold leaf electroscope.

(1 mk)

11. the anode of an x-ray tube becomes hot when the tube is in use. State the reason for this.

(1 mk)

12. Draw a ray diagram to show how a ray of light may be totally internally reflected two times in an isosceles right-angled glass prism.  
(Assume that the critical angle of glass is  $42^\circ$ )

(2 mks)

13. The current of electrons hitting the screen of a cathode ray oscilloscope is  $2.0 \times 10^{-4}$  A. determine the number of electrons that strike the screen each second. (take charge of an electron as  $1.6 \times 10^{-19}$  C)

(3 mks)

### SECTION B (55mks)

14 a) figures 6 show a simple electric bell circuit.

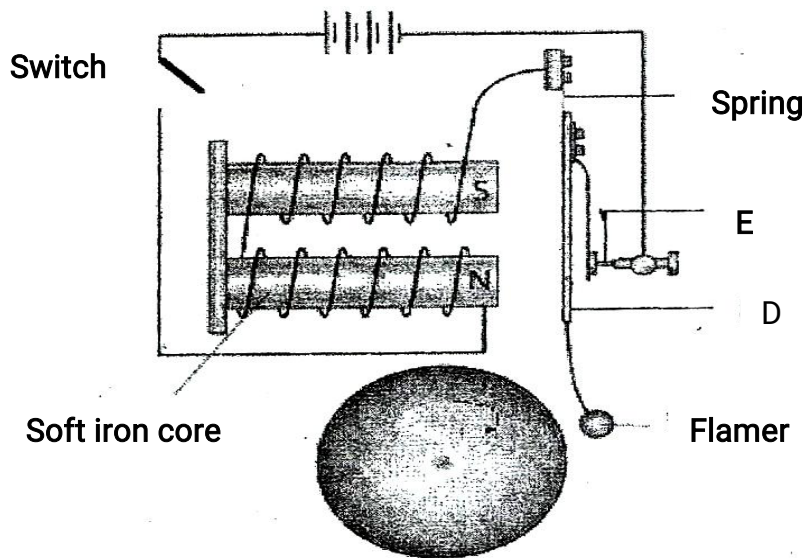

Figure 6

i) Name the parts labeled:

- (I) D
- (II) E

(1 mk)

(1 mk)

ii) When the switch is closed, the hammer hits the gong repeatedly.  
Explain why:

i) The hammer hits the gong.  
(2mks)

ii) The hammer hits the gong repeatedly. (3mks)

b) An electric bulb is rated 60W, 240 V. Determine

i) The current that flows through it when it is connected to a 240 V supply  
(3mks)

ii) The resistance of the bulb (3mks)

15. a) One of the causes of energy loss in a transformer is heating in the coils when current flows. State;

i) The reason why the current causes heating. (1mk)

ii) How the heating can be minimized (1mk)

b) The input voltage of a transformer is 240 V and its output is 12 V. When an 80 W bulb is connected across the secondary coil, the current in the primary coil is 0.36A.

Determine

i) The ratio  $\frac{N_p}{N_s}$  of the transformer, (*where  $N_p$  is the number of turns in the primary coil and  $N_s$  is the number of turns in the secondary coil*)  
(3mks)

ii) The power input of the transformer  
(3mks)

iii) The power output of the transformer  
(1mk)

iv) The efficiency of the transformer 2mks

16. a) Figure 7 shows resistors  $R_1$  and  $R_2$  connected in parallel. Their ends are

connected to a battery of potential difference V volts.

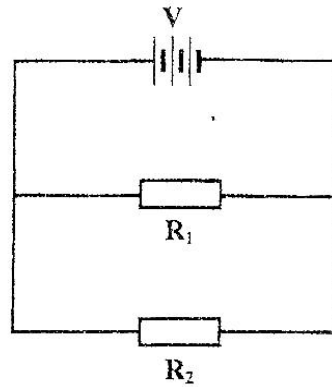

Figure 7

i) In terms of V, R<sub>1</sub> and R<sub>2</sub>, write an expression for

I) Current I<sub>1</sub> through R<sub>1</sub>

(1mk)

II. Current I<sub>2</sub> through R<sub>2</sub>.

(1mk)

III total current I in the circuit.

(1 mk)

ii. Show that the total resistance R<sub>T</sub> is given by  $R_T = \frac{R_1 R_2}{R_1 + R_2}$

b) Figure 8 shows a negatively charged rod placed near an uncharged conductor resting on an insulating support

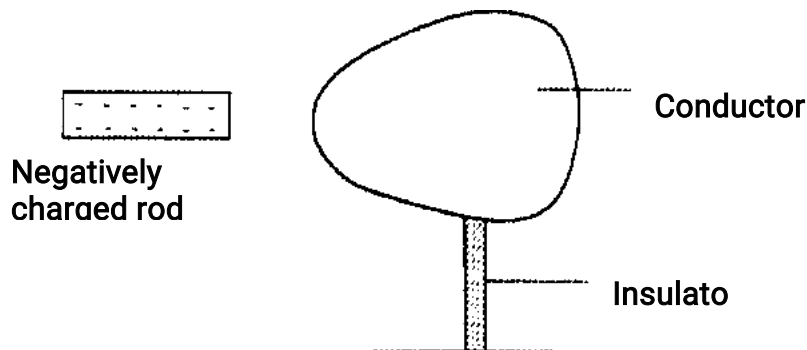

Figure 8

i) Show the charge distribution on the conductor

(2mks)

ii) State the effect

I) Of momentarily touching the conductor with a finger while the charged rod is still near the conductor

(1mk)

II) On the charge distribution of withdrawing the negatively charged rod after momentarily touching the conductor

(1 mks)

III) In the space provided, sketch a diagram to show how the charge in ii (II) would have been distributed if the conductor was a sphere

(1mk)

17. a) Figure 9 shows two speakers  $S_1$  and  $S_2$  which produce sound of the same frequency.

They are placed equidistant from a line AB and a line PQ. (PQ is perpendicular to line AB)

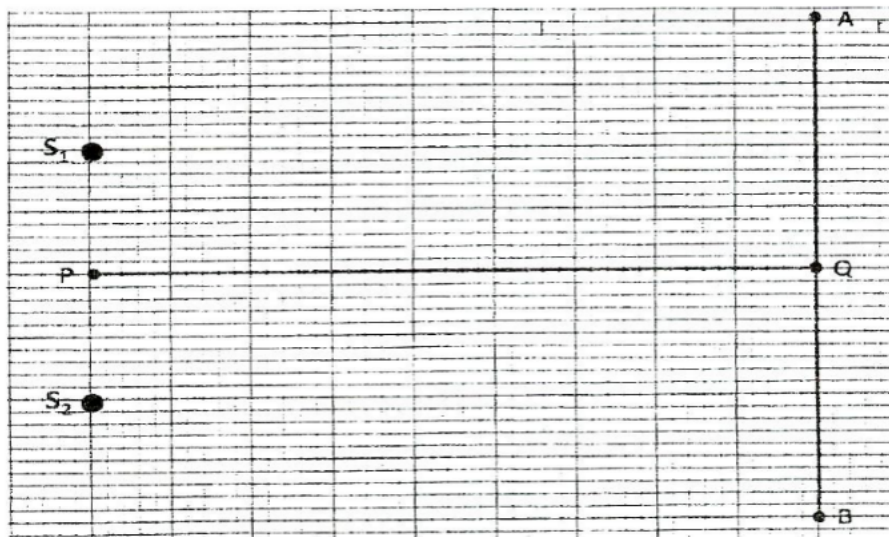

Figure 9

i) A student walking from A to B hears alternating loud and soft sounds. Explain why at some point the sound heard is soft

(2mks)

ii) The student now walks along line PQ. State with reason the nature of the sound the student hears

(3mks)

b) Figure 10 shows sound waves in air produced by a vibrating tuning fork. R is an air molecule on the path of the wave

Oscillation

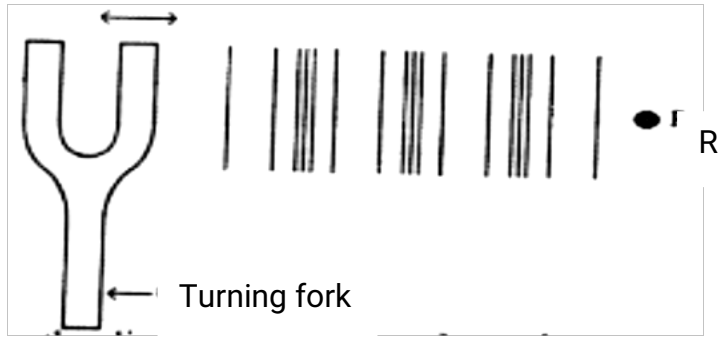

i) Using a line, indicate on the diagram a distance  $d$  equal to one wavelength of the wave.

(1mk)

ii) In the spaces provided, show with an arrow the direction of motion of the air molecule  $R$  as the waves pass.

(1mk)

iii) Explain the reason for the answer in (ii)

(2mks)

18. Figure 11 shows an object placed  $10c$  in front of a concave mirror whose radius of curvature is  $40\text{ cm}$ .

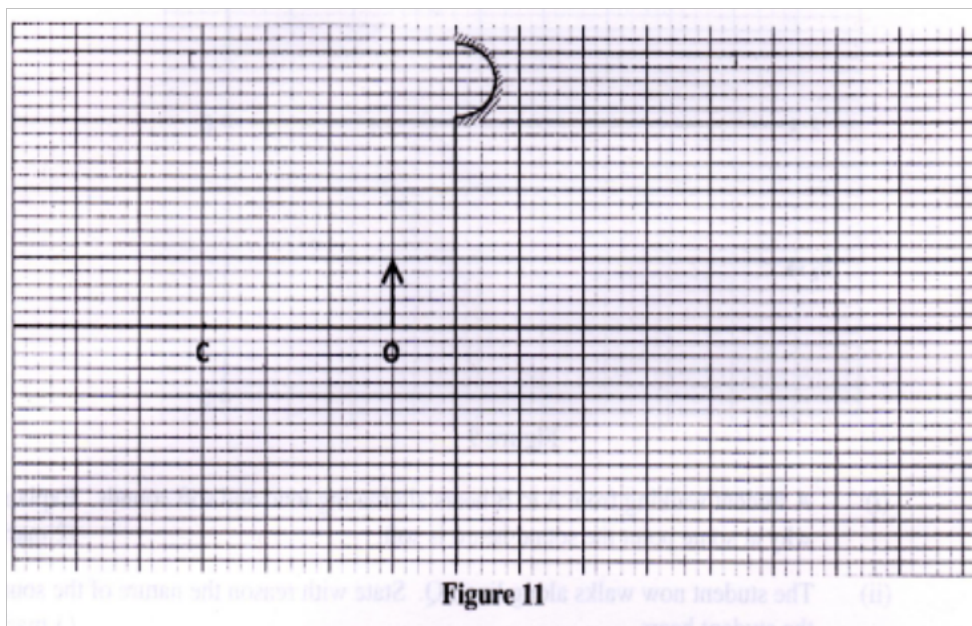

Ai) On the same figure, draw a ray diagram to show the position of the image formed

(3mks)

ii) Use the ray diagram to determine

i) the image distance

(1mk)

III)The magnification (3mks)

iii) State where the position of the image would be if the object had been placed at the principal focus (1mk)

b) Draw a ray diagram show the formation f a partially dark shadow and a totally darks shadow during the eclipse of the sun

**K.C.S.E 2015  
PHYSICS PAPER 232/2  
QUESTIONS**

**SECTION A: (25 marks)**

*Answer all the questions in this section in the spaces provided.*

1. Figure 1 shows three mirrors arranged at right angles to each other. A ray of light is incident on one of the mirrors.

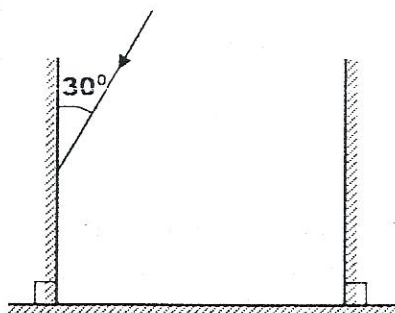

**FIGURE 1**

Complete the diagram to show the path of the ray after reflection on each of the mirror

(3 mks)

2. It is observed that when a charged body is brought near the cap of a positively charged, electroscope, the divergence of the leaf increases. State the type of charge on the body.

(1 mk)

3. State the reason for topping up a lead - acid accumulator with distilled water.

(1 mk)

4. Figure 2 shows a soft iron bar AB placed in a coil near a freely suspended magnet.

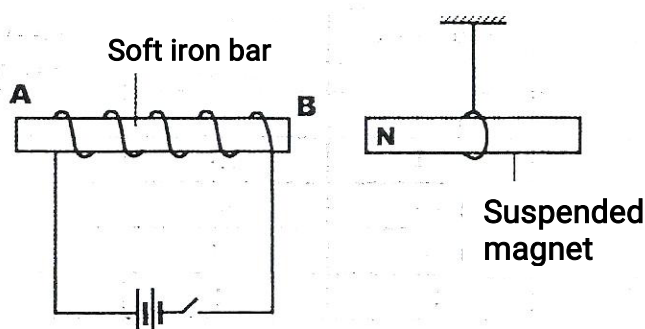

**Figure 2**

Explain the observation made when the switch is closed.

(2 mks)

5. State the reason why a convex mirror is preferred over a plane mirror for use as



a driving mirror.

(1 mk)

6. State two ways in which the strength of an electromagnet can be increased.

(2 mks)

7. State two differences between electromagnetic waves and mechanical waves.

(2 mks)

8. Figure 3 shows straight waves incident on a diverging lens placed in a ripple tank to reduce its depth.

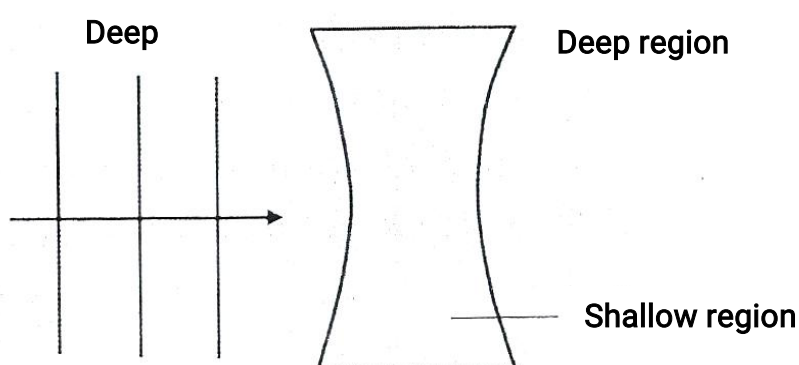

Figure 3

Complete the diagram to show the waves in both the shallow region and beyond the lens

(2 mks)

9. A ship in an ocean sends out an ultra sound whose echo is received after 3 seconds. If the wavelength of the ultra sound in water is 7.5 cm, and the frequency of the transmitter is 20 kHz, determine the depth of the ocean.

(3 mks)

10. A nail at the bottom of a beaker containing glycerine appears to be 6.8 cm below the surface of glycerine. Determine the height of the column of glycerine in the beaker. (*take the refractive index of glycerine as 1.47*)

(3 mks)

11. State one application of thermionic emission.

(1 mk)

12. Figure 4 shows a cathode ray entering into a region between two charged plates.

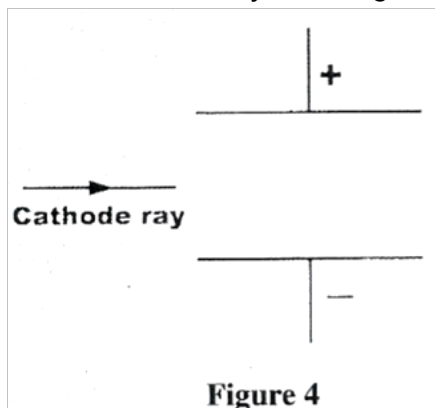

Complete the diagram to show the path of the ray in the field.

13. When a transformer is connected to an ac source, the output voltage is found to be 24 V. If the power input is 200 W, determine the output current. (*Assume the transformer is 100% efficient*). (3 mks)

### SECTION B: (55 mks)

*Answer all the questions in this section in the spaces provided.*

14. (a) State two factors that affect photoelectric emission. (2 mks)

(b) Light of wavelength  $4.3 \times 10^{-7} \text{ m}$  is incident on two different metal surfaces, nickel and potassium. (*Take speed of light as  $3.0 \times 10^8 \text{ ms}^{-1}$  and planks constant  $h$  as  $6.63 \times 10^{-34} \text{ Js}$* ).

(i) Determine the energy of the incident radiation. (3 mks)

(ii) If the work function of nickel is  $8.0 \times 10^{-19} \text{ J}$  and that of potassium is  $3.68 \times 10^{-19} \text{ J}$ , state with a reason from which of the two metals the given light will eject electrons. (2 mks)

(iii) Determine the velocity of the emitted electrons from the metal surface in b(ii). (*Take the mass of an electron as  $9.1 \times 10^{-31} \text{ kg}$* ). (3 mks)

15. (a) State two factors that determine the resistance of a metallic conductor. (2 mks)

- (b) Explain how a fuse safeguards electrical appliances against excessive currents.  
(2 mks)
- (c) A hair dryer is rated 2.5 kW, 240V.
- (i) Determine whether a 10 A fuse may be suitable for the hair dryer.  
(5 mks)
- (ii) Determine the cost of using the hair dryer for 3 hours if the cost of electricity is Ksh 0.80 per kilowatt hour. (2 mks)
- 16 (a) It is observed that alpha ( $\alpha$ ) particles have a lower penetrating power than beta particles. Explain this observation.  
(2 mks)
- (b) A radioactive substance has a half life of 12 years. Determine the time it would take to decay to 12.5% of its original value. (2 mks)
- (c) A Geiger Muller (GM) tube is used for detecting radiations from a radioactive source. State the function of
- (i) the mica window; (1 mk)
- (ii) bromine gas in the tube. (1 mk)
- (d) (i) In a diffusion chamber, explain why some of the tracks formed are observed to
- (I) Short, (2mks)
- (II) Straight (2mks)
- (ii) State two advantages of using a GM tube instead of a diffusion cloud chamber to detect radiations from radioactive substances.  
(2 mks)
17. (a) State three factors that affect the capacitance of a parallel plate capacitor. (3 mks)
- b) Figure 5 shows the circuit used to charge a capacitor C

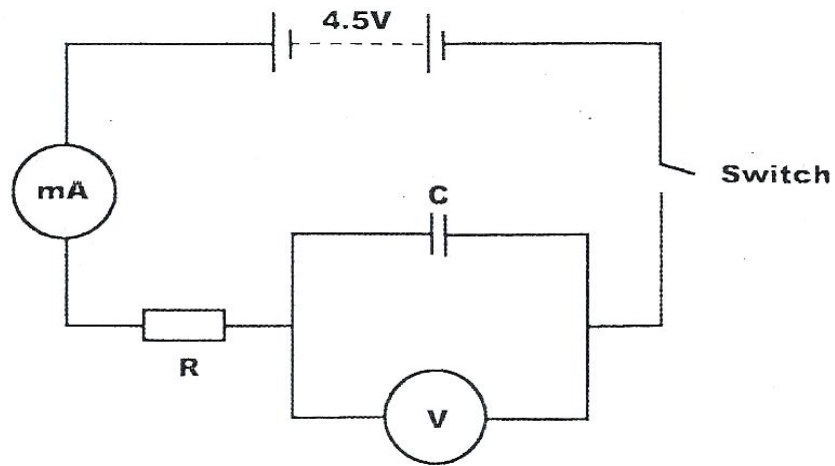

Figure 5

- i) State what would be observed on the following when the switch is closed
- I) The milliammeter (1 mk)
  - II) The voltmeter (1 mk)
- ii) Explain how the capacitor gets charged (3 mks)
- iii) State the purpose of the resistor R. (1 mk)
- (iv). On the axes provided, sketch the graph of voltage (V) against time (t). (2 mks)



18. (a) Three resistors of resistance  $2\ \Omega$ ,  $3\ \Omega$  and  $4\ \Omega$  are to be connected to a cell such that they have the least effective resistance.
- (i) Draw a circuit diagram to show how they can be connected to achieve this. (2 mks)
  - (ii) Determine the least effective resistance of the three resistors. (3 mks)

(b) A real object of height 1 cm placed 50 mm from a converging lens forms a virtual image 100 mm from the lens.

- (i) Determine the:  
(I) focal length of the lens;

(3 mks)

(II) magnification

(2 mks)

- ii) On the grid provided draw to scale the ray diagram for the set up, to show how the image is formed

(3 mks)

## K.C.S.E 2016 PHYSICS PAPER 232/2 QUESTIONS

### SECTION A: (25 mks)

Answer all the questions in this section in the spaces provided.

1. **Figure 1** shows a ray of light incident on a mirror, at an angle of  $45^\circ$ . Another mirror is placed at an angle of  $45^\circ$  to the first one as shown.

(2mks)

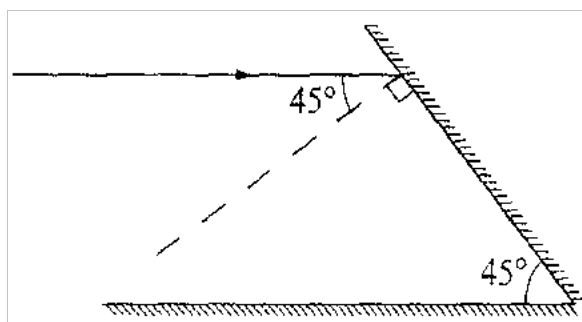

Sketch the path of the ray until it emerges.

2. An unmagnetized steel rod is clamped facing North-South direction and then hammered repeatedly for some time. When tested, it is found to be magnetized.

Explain this observation

(2mks)

3. **Figure 2** shows a solenoid carrying an electric current.

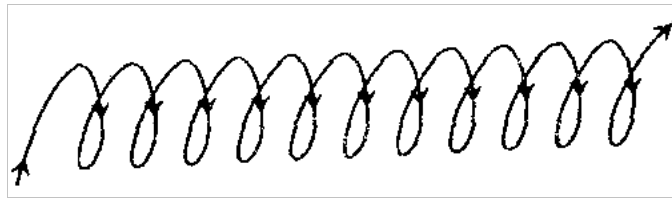

Sketch the magnetic field pattern inside and at the ends of the solenoid.

(1mk)

4. **Figure 3** shows how the displacement of a point varies with time as a wave passes it

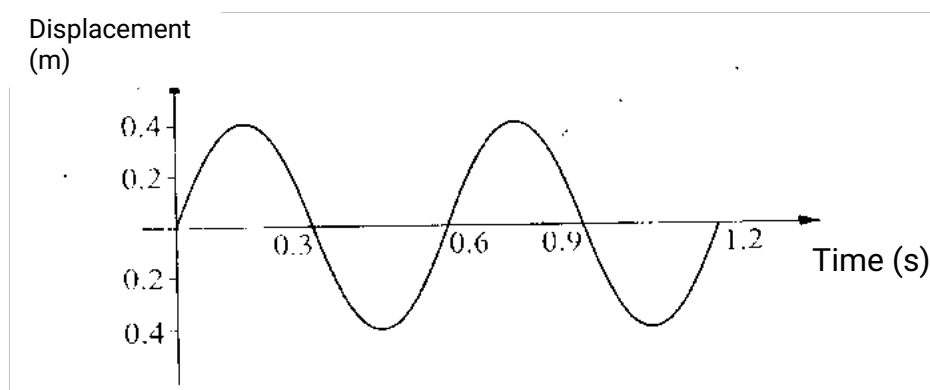

**figure 3**

On the same diagram, draw a wave which passes the point with half the amplitude and twice the frequency of the one shown.

(2 mks)

5. State the reason why a convex mirror is preferred over a plane mirror for use as a driving Mirror (1 mk).

6. Figure 4 shows straight waves incident on a diverging lens placed in a ripple tank to reduce its depth. Complete the diagram to show the waves in both the shallow region and beyond the lens.

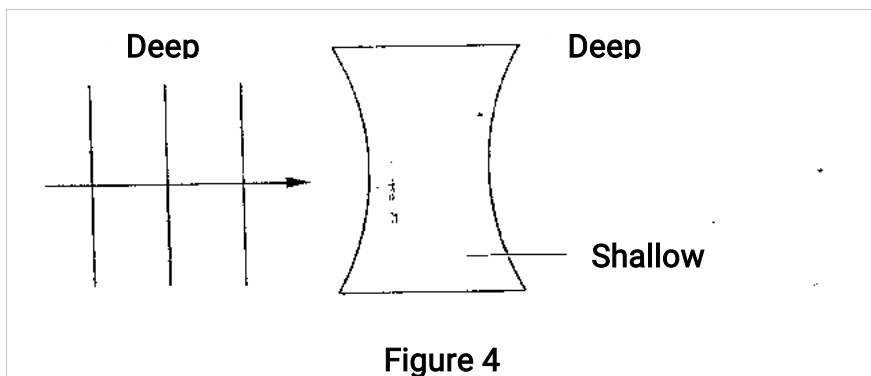

4. Figure 5 shows the cross section of a dry cell. Use the information on the figure to answer question 7.

**Brass cap  
+ve contact**

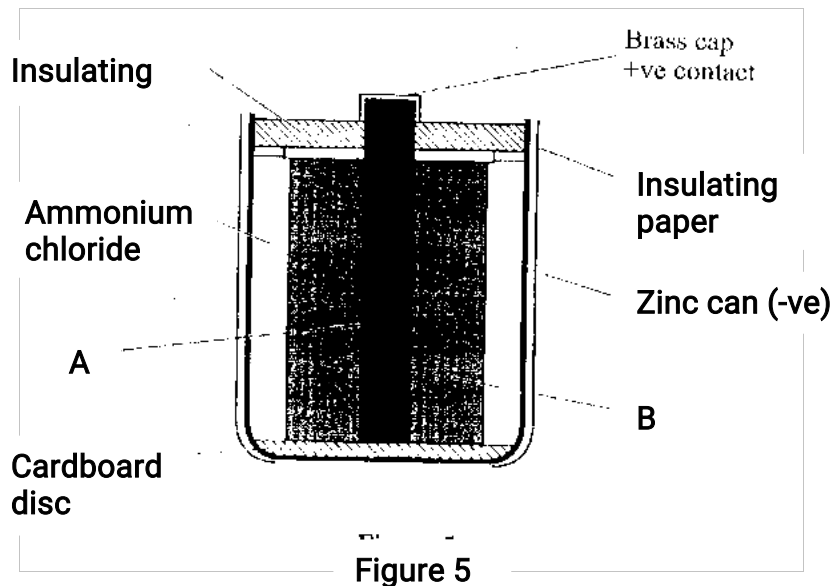

- a) Name the parts labeled A and B (2mks)
- b) State the use of the manganese (IV) oxide in the cell (1 mk)

8. The following is part of a radioactive series

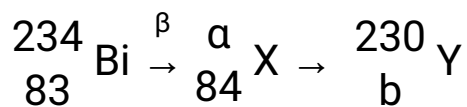

Determine the values of a and b (2 mks)

A = ..... b = .....

9. Draw a ray diagram to show how a ray of light may be totally internally reflected two times in an isosceles right-angled glass prism. (Assume that the critical angle of glass is  $42^\circ$ .) (2 mks)



10. Figure 6 shows a narrow beam of X-rays passing between two metal plates in air. The plates are connected in series with a switch, a cell and a milliammeter.

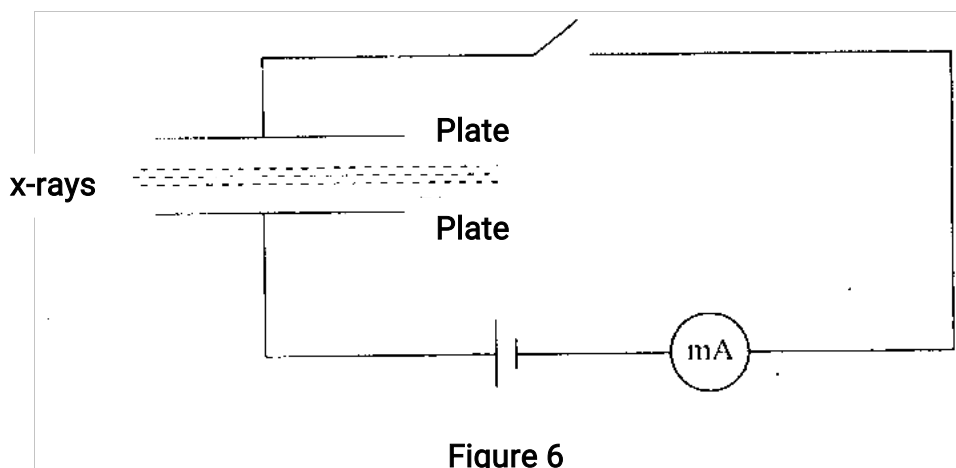

It is observed that when the switch is closed a current flows in the milliammeter. Explain this observation.

11. A heater of resistance  $R_1$  is rated  $P$  watts,  $V$  volts while another of resistance  $R_2$  is rated  $2P$  watts,  $V/2$  volts. Determine  $R_1/R_2$  (2 mks)
12. When a germanium crystal is doped with arsenic, it becomes an N-type semi-conductor. Explain how this change occurs. (2 mks)  
(Number of electrons in the outermost shell for germanium = 4, Arsenic = 5)
13. A boy standing in front of a cliff blows a whistle and hears the echo after 0.5 s. He then moves 17 metres further away from the cliff and blows the whistle again. He now hears the echo after 6.0s. Determine the speed of the sound.

(2 mks)

Kenya Certificate of Secondary Education, 2016

SECTION B: (55 MKS)

Answer all the questions in this section in the spaces provided

14. a) Figure 7 shows a simple electric bell circuit

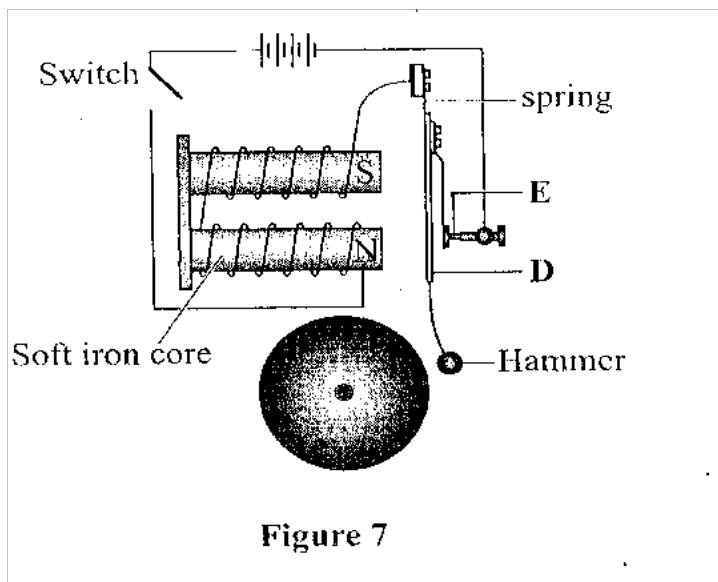

i) Name the parts labeled

I. D

(1 mk)

II. E

(1mk)

ii) When the switch is closed, the hammer hits the gong repeatedly. Explain why;

i. The hammer hits the gong

(2 mks)

ii. The hammer hits the gong repeatedly

(2 mks)

(b) An electric bulb is rated 60 W, 240V. Determine:

(i) the current that flows through it when it is connected to a 240V supply.

(ii) the resistance of the bulb

15. Figure 8 shows two coils A and B placed close to each other. A is connected to a steady direct . current (d.c.) supply and a switch, B is connected to a sensitive galvanometer.

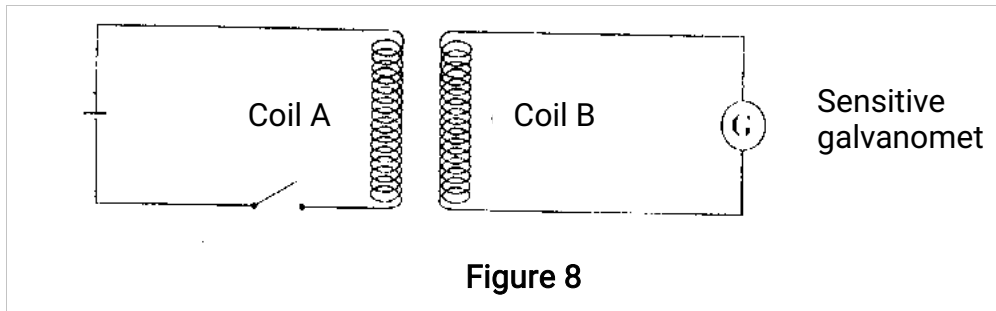

- (a) (i) The switch is now closed. State the observation made on the galvanometer.
- (ii) Explain what would be observed if the switch is when opened.
- b) The primary coil of a transformer has 1000 turns and the secondary coil has 200 turns. The primary coil is connected to a 240V alternating current (a.c.) mains supply.
- i) Explain how an e.m.f is induced in the secondary coil.  
(2 mks)
- ii) Determine the secondary voltage  
(2 mks)
- iii) Determine the efficiency of the transformer given that the current in the primary coil is 0.20 A and in the secondary coil is 0.80 A. (3 mks)
16. a) Figure 9 shows a circuit that may be used to charge a capacitor

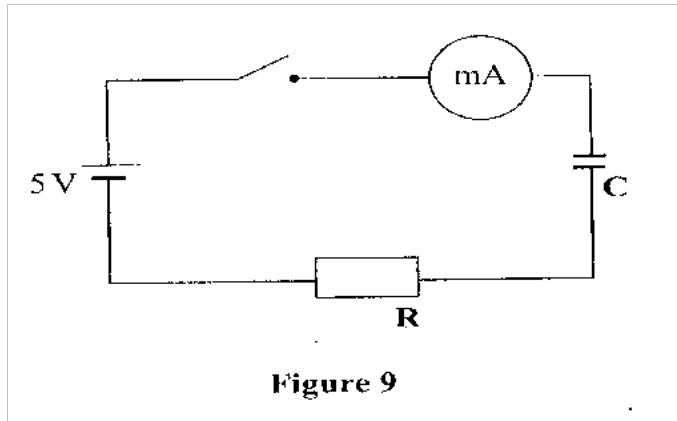

i) State the observation on the milliammeter when the circuit is switched on.

(1mk)

ii) Explain the observation in a (i) above

(2 mks)

b) The circuit in figure 9 is left on for duration of time. state the value of potential difference (p.d.) across

i.) the resistor R

(1 mk)

ii) the capacitor C

(1 mk)

c) Sketch the graph of potential difference V across R against time

(1 mk)

d) Figure 10 shows three capacitors connected to a 10V battery.

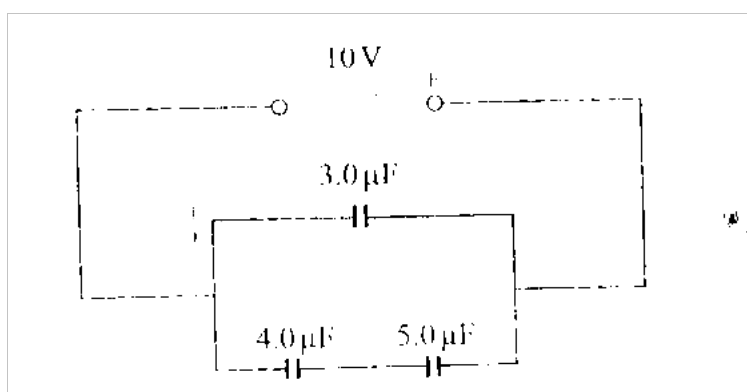

Calculate:

(i) the combined capacitance of the three capacitors

(3 mks)

(ii) the charge on the 5.0u-F capacitor.

(3 mks)

17. (a) When a radiation was released into a diffusion chamber, short thick tracks were observed. State with a reason, the type of radiation that was detected.

(2 mks)

(b) The half-life of an element X is 3.83 days. A sample of this element is found to have an activity of  $1.0 \times 10^3$  disintegrations per second at a particular time. Determine its activity rate after 19.15 days.

(3 mks)

(c) State what is meant by an extrinsic semi-conductor.

(2 mks)

(d) Figure 11 shows a depletion layer in an unbiased p-n junction.

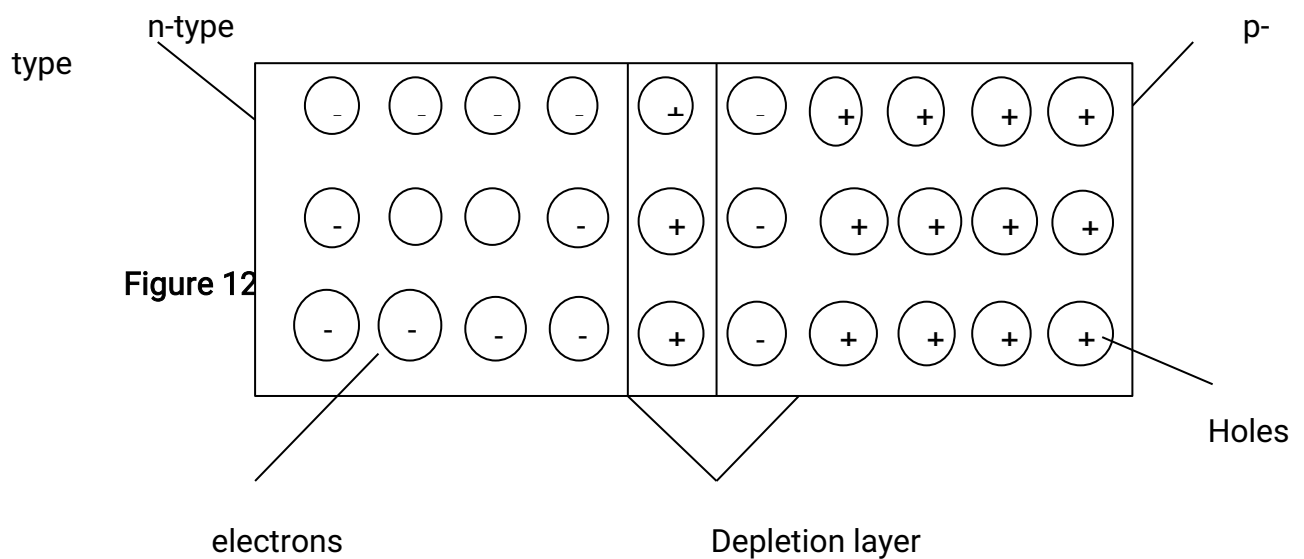

State how a battery can be used to make the depletion layer narrower.

(1mk)

(e) **Figure 12** shows an incomplete circuit of a full wave rectified

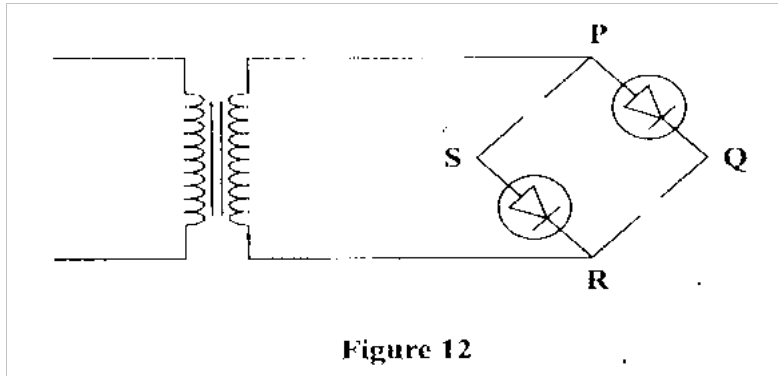

**Figure 12**

Draw in the figure 12 two more diodes to complete the circuit.  
(2mks)

(ii) Show on the **Figure 12** the points across which the output of the rectifier should be obtained  
(2 mks)

18. (a) State one factor that affects the speed of sound in a solid.  
(1mk)

(b) An observer stands half-way between two vertical cliffs that are  $L$  metres apart. He strikes a gong and measures the time interval,  $t$ , between the echoes heard from the two cliffs. He moves a further 10m and again strikes the gong and measures the time interval  $\hat{t}$  between the echoes. The process is repeated several times. The graph in Figure 13 shows the relation between the time interval;  $t$  and the distance,  $x$ , from the centre.

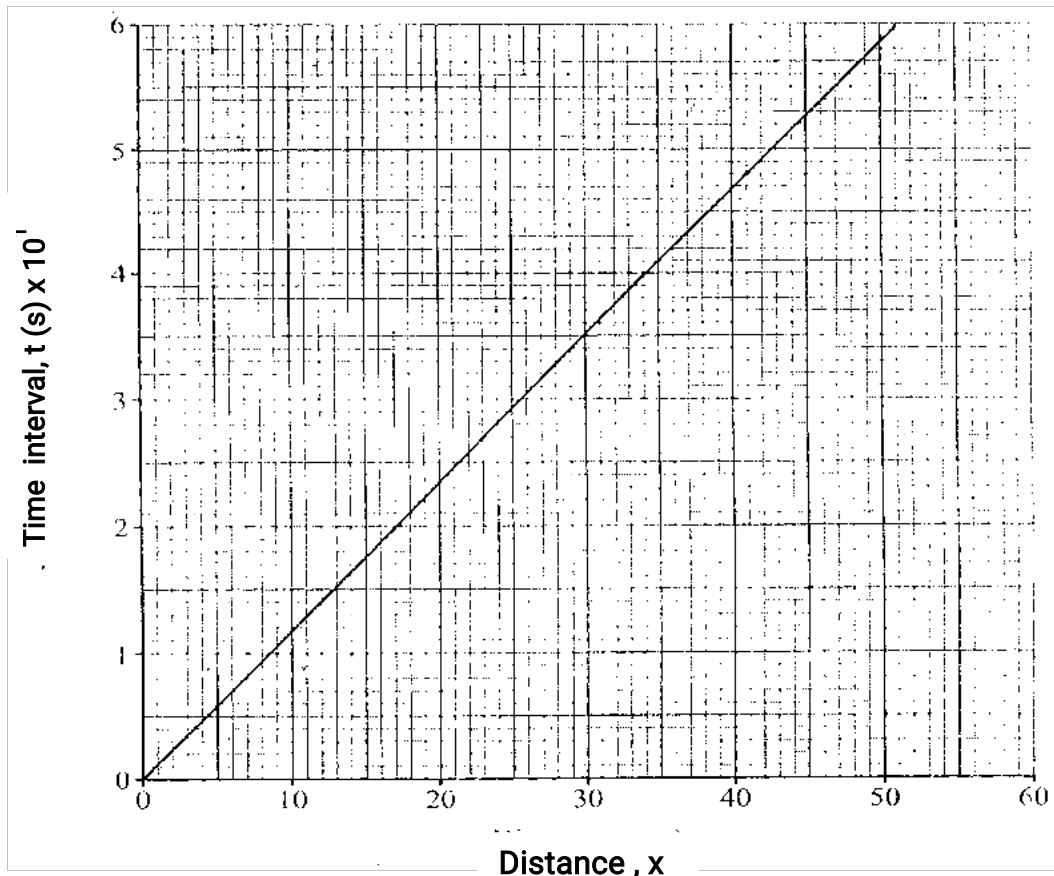

Figure 13

- (i) From the graph, determine the value of  $x$  for which the time interval was 0.55 seconds (1mk)
- (ii) Give that  $t = 4x/v$ , where  $v$  is the speed of sound in air, determine the value of  $v$  from the graph (3 mks)
- (iii) If the maximum time measured by the observer was  $t = 4.75s$ , determine the distance  $L$  between the cliffs. (3 mks)

(c) A search boat uses a signal of frequency  $6.0 \times 10^4 \text{ Hz}$  to detect a sunken ship directly

below. Two reflected signals are received; one after 0.1 seconds from the sunken boat and the other after 0.14 seconds from the sea bed. If the sea bed is 98 m below the boat, determine:

- (i) the speed of the signal in water. (3 mks)  
(You may use the value of  $v$  of (ii) on page 14).

(ii) the depth of the sunken ship below the boat.

(2mks)





*'an investment of knowledge pays*

The following KASNEB notes are available;

 **ATD**

 **CPA**

 **CS**

 **CIFA**

*Call Mdm.Mariam;0746711892 to acquire them*



