

Name.....Index no.....Adm No.....

SCHOOL.....CANDIDATE'S SIGN.....

232/1

PHYSICS

PAPER 1

2 HOURS

2018

GATUNDU SOUTH SUB- COUNTY EVALUATION EXAMINATION

KENYA CERTIFICATE OF SECONDARY EDUCATION

INSTRUCTIONS TO CANDIDATES

1. WRITE YOUR NAME INDEX NUMBER AND ADMISSION NUMBER.
2. THIS PAPER CONSISTS OF TWO SECTIONS A AND B.
3. ANSWER **ALL** THE QUESTION IN THE SPACE PROVIDED.
4. ALL WORKING **MUST** BE CLEARLY SHOWN.
5. MATHEMATICAL TABLE AND ELECTRONIC CALCULATORS MAY BE USED.

FOR EXAMINER'S USE ONLY

SECTION	QUESTION	MAXIMUM SCORE	CANDIDATE SCORE
A	1- 13	25	
B	14	12	
	15	13	
	16	10	
	17	12	
	18	8	
	TOTAL		80

SECTION A (25MARKS)

Answer **all** the questions in this section in the space provided

1. Figure 1 shows the changes in volume of water in measuring cylinder when an irregular solid is immersed in it.

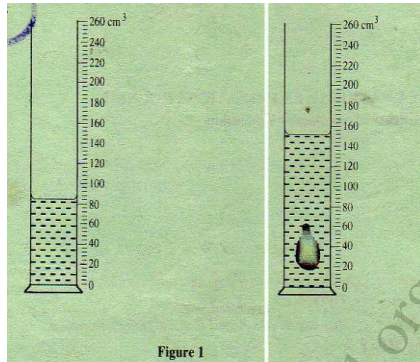

Given that mass of the solid is 567g, determine the density of the solid in gcm^{-3} (Give your answer correct to 2 decimal places). (3marks)

.....
.....

- 2 .(I)State two measurements you would take in an experiment to determine the upthrust of an object which is immersed in a fluid. (2 marks)

.....
.....

- (II)State how the measurement in question (5) is used to determine the up thrust of the object. (1 mark)

.....
.....

3. An object placed on a horizontal surface moves with a constant velocity. what would happen to the object if no external force (1mark)

.....
.....

4. Water is known to boil at 100°C .A student heated some water and noticed that it boiled at 101°C .

State two possible reasons for this observation. (2 marks)

.....
.....

5. Fig. 2 shows a flask filled with water .The flask is fitted with a cork through which a tube is inserted. When the flask is cooled, the water level rises slightly, and then falls steadily.

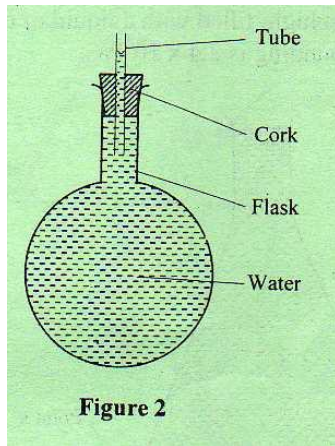

Explain this observation. (2 marks)

.....

.....

.....

7. fig. 3 shows a sheet of paper rolled into a tube

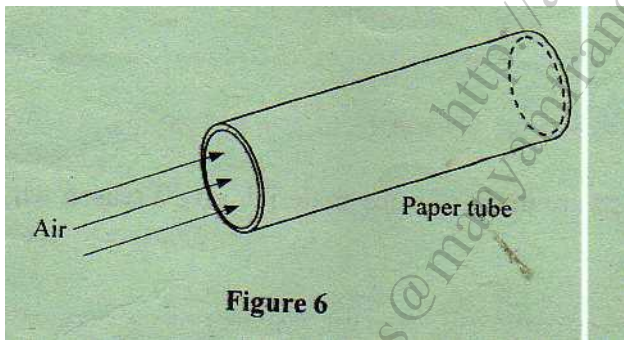

When a fast stream of air is blown into the tube as shown in the diagram the paper tube collapses. Explain the observation. (2 marks)

7. Figure 4 shows a uniform metal rod balanced at its Centre by different forces.

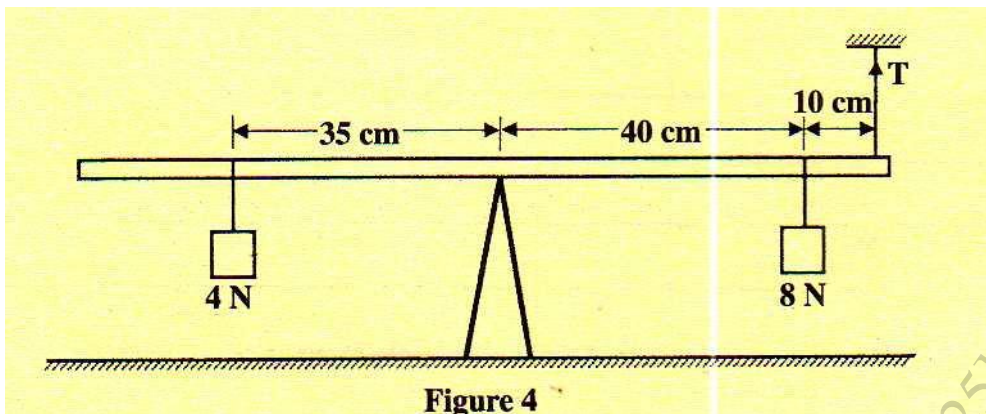

Determine the value of T (3 marks)

8. An object of weight 20N attached at the end of a spring causes an extension of 0.5cm on the spring.

(a) determine the spring constant of the spring. (2marks)

(b) Determine the weight of an object that would cause an extension of 0.086cm when attached at the end of the spring. (1mark)

9. On the axis provided, sketch the graph which shows the relationship between volume and temperature of a fixed mass of water in the temperature range 0°C to 10°C . (1 mark)

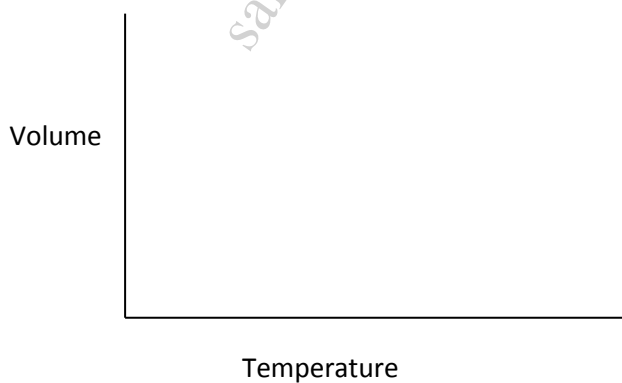

10. Figure 5 shows a graph of the variation of temperature with time for a pure substance heated at a constant rate.

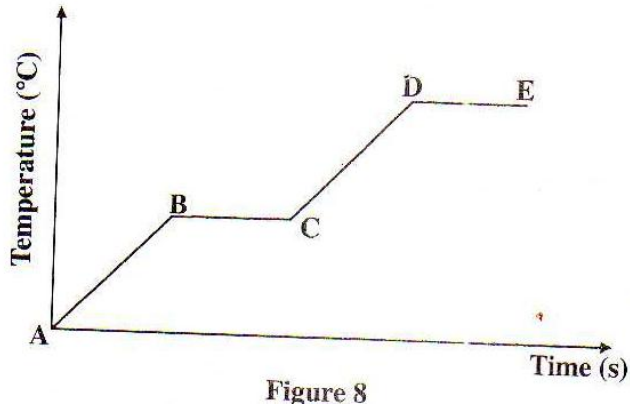

Assuming that the heat transfer to the surroundings is negligible, state the changes observed on the substance in region:

(a) BC; (1 mark)

.....

(b) DE; (1 mark)

.....

11. A clinical thermometer has a constriction in the bore just above the bulb. State the use of this constriction (1 mark)

.....

.....

12. A bottle containing a smelling gas is opened at the front bench of a classroom. State the reason why the gas is detected throughout the room (1mark)

.....

13. State the reason why a steel sphere resting on a horizontal surface is said to be in neutral equilibrium (1mark)

.....

.....

SECTION B (55 MARKS)

Answer **all** the questions in this section in the space provided

14. (a) state what is meant by an *ideal gas* (1 mark)

.....

(c) The pressure acting on a gas in a container was changed steadily while the temperature of the gas was maintained constant. The value of volume V of gas was measured for various values of pressure. The graph in Figure 9 shows the relation between the pressure, p , and the reciprocal of volume $1/v$

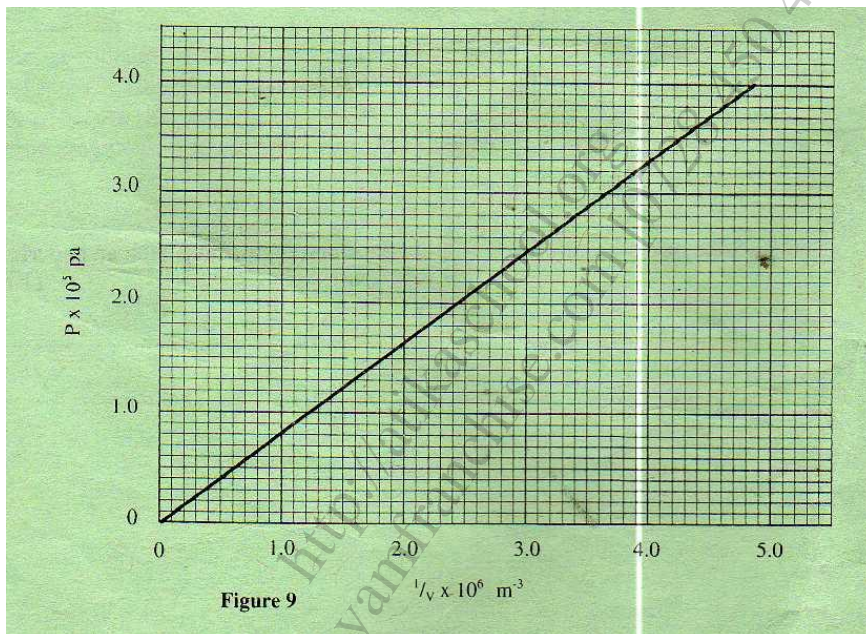

i) Suggest how the temperature of the gas could be kept constant.(1 mark)

.....

ii) Given that the relation between the pressure p_1 and the volume, of the gas is given by

$$PV=K$$

When k is a constant, use the graph to determine the value of k .(4 marks)

iii) What physical quantity does k represent? (1 mark)

.....

iv) State **one** precaution you would take when performing such an experiment.(1mark)

.....

(c) A gas occupies a volume of 4000 litres at a temperature of 37°C and normal atmosphere pressure .Determine the new volume of the gas if it is heated at constant pressure to a temperature of 67°C (normal atmosphere pressure= 1.01×10^5 Pa). (4 marks)

15.(a) A warm bottle of soda placed in ice at 0°C cools faster than when the same soda is placed in water at the same temperature .Explain this observation (2marks)

.....
.....

(b) Figure 6 shows an incomplete circuit set up that can be sued in experiment to determine the specific heat capacity of a solid block by electric method .Study the diagram and answer the questions that follow

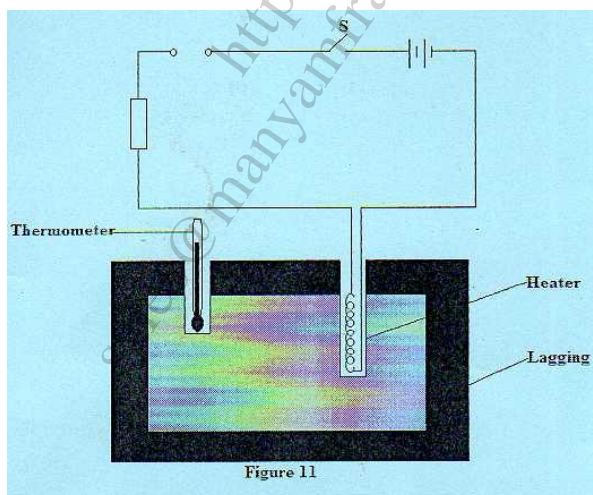

i) State the purpose of the rheostat in the experiment (1 mark)

.....

ii) Complete the diagram by inserting the missing components the experiment to work. (2 marks)

.....

iii) Other than temperature ,state three measurement that should be taken (3 marks)

.....
.....
.....

c) Figure 12 shows a set- up of apparatus used in an experiment to determine the specific latent heat of fusion of ice. Study the diagram and answer the questions that follow

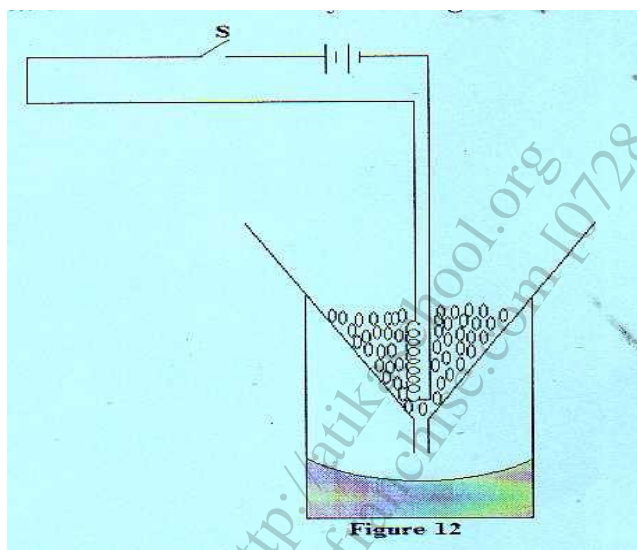

The following readings were noted after the heater was switched on for 10 minutes

-mass of the beaker =260g

-Mass of the beaker +melted ice=280g

Determine

i) The energy supplied by 120W heater in the 10 minutes (2 marks)

ii) The specific latent heat of fusion of the ice (2 marks)

iii) The experiment value for the specific latent heat of fusion of ice obtained is less than the theoretical value .Give one reason for this observation (1 mark)

.....

16. The figure **below** shows a lift pump.

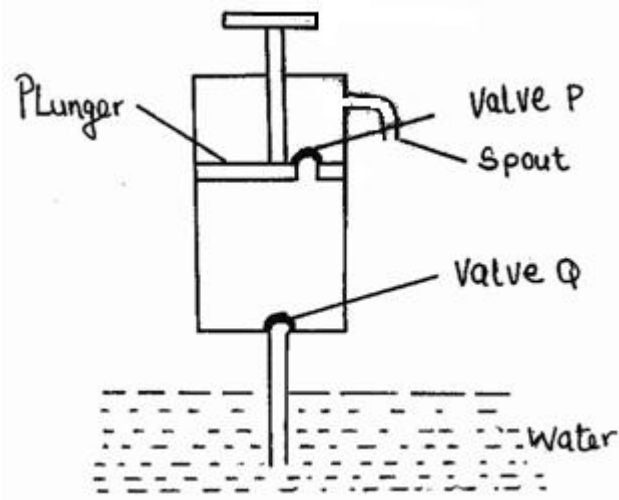

Explain why, when the piston is

(i) Pulled upwards, valve **Q** opens while valve **P** closes. (2mks)

.....

(ii) Pushed downwards, valve **Q** closes while valve **P** opens. (2mks)

.....

(iii) State two advantages of a force pump over the lift pump. (2mks)

.....

b) A lift pump can lift water to a maximum height of 10m.determine the maximum height to which the pump can raise alcohol (take density of alcohol as 800kg/m^3 and density of water as 1000kgm^3)

(3marks)

c) State one factor that determine the height to which a force pump can lift water. (1mark)

.....

17. Use figure 7 below to answer the questions

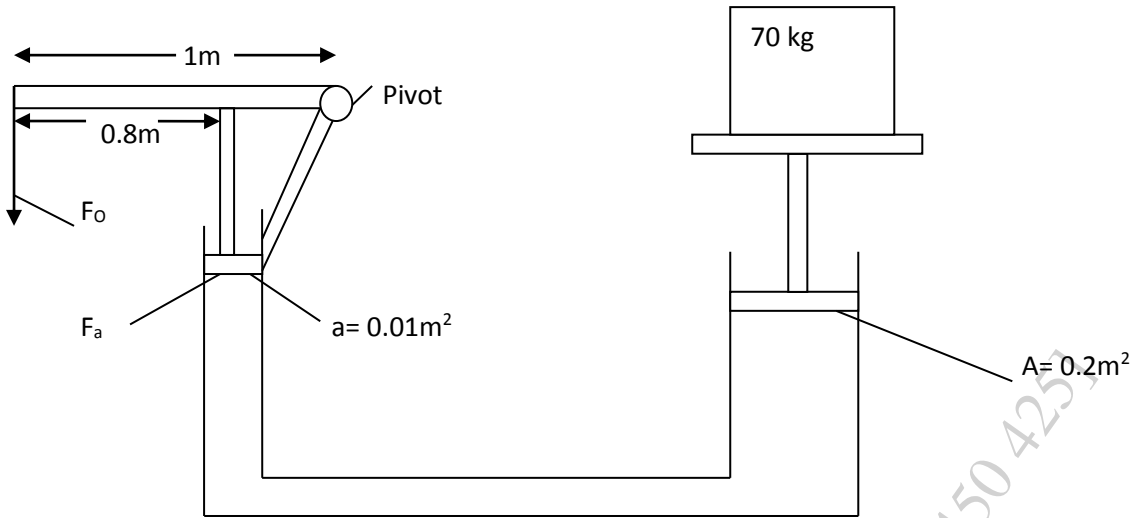

If A and a are areas of cross-sections of the pistons and the lengths of the arm are as given. Find

a) (i) the value of force F_o (4 marks)

(ii) Mechanical advantages of the machine (2 marks)

(ii) velocity ratio of the machine (3marks)

(iv) The efficiency of the machine (3marks)

18. (a) (i) a car goes round a flat circular bend whose radius is 100m at a constant speed of 30m/s. Calculate its acceleration. (2marks)

(ii) If the mass of the car is 1500kg, calculate the frictional force required to provide this acceleration. (3marks)

(b) (i) calculate the maximum speed at which the car can go round the bend without skidding if the coefficient of friction between the tyres and the ground is 0.5 (2marks)

(ii) Give a reason why the driver of the car has to move through the same bend at a lower speed during a rainy day (1mark)

