

ASSIGNMENT ONE

1. The figure below shows a scale which is part of vernier calipers. What is the reading indicated by the scale? (2mks)

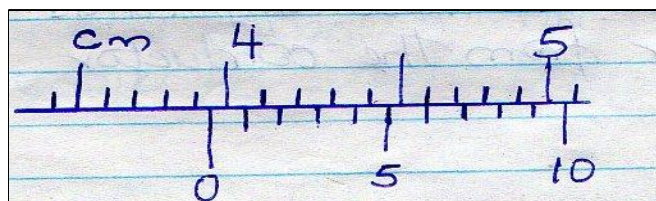

2. Two mirrored walls stand at an angle to each other. A student standing in the room counts nine images of himself in the mirrors. Determine the angle between the walls (3mks)
3. The diagram below shows the behavior of mercury in a capillary tube. Explain this observation (2mks)

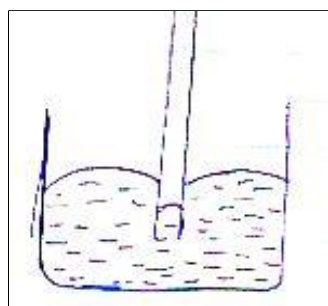

4. A body weighs 600N on the surface of the earth and 450N on the surface of another planet. Calculate the value of g in that planet (g on the earth = 10N/Kg) (3mks)
5. A steel needle when placed carefully on water can be made to float. When a detergent is added to the water it sinks. Explain this observation (2mks)
- 6.
7. 200 coulombs of charge passes through a point in a circuit for 0.6 minutes. What is the magnitude of the current flowing? (3mks)
8. When marking the fixed points on a thermometer it is observed that at 0°C , the mercury thread is of length 1 cm and 6cm at 100°C . What temperature would correspond to a length of 4cm? (3mks)

9. The micrometer screw gauge below has a zero error of -0.19mm

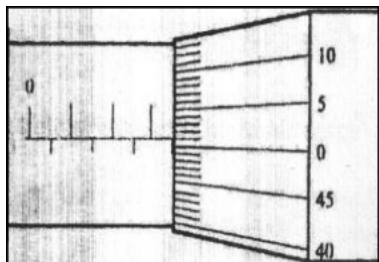

Determine the actual thickness of the object.

(2mks)

10. Distinguish between hard magnetic material and a soft magnetic material

(2mks)

11. In the smoke cell experiment, bright specks are observed to move in a continuous random manner. Explain this motion.

(2mks)

12. State the reason why a steel sphere resting on a horizontal surface is said to be in neutral equilibrium

(1mk)

13. (a) State Hooke's law

(1mk)

(b) In an experiment to verify Hooke's law, a piece of rubber was fixed to a rigid support and the other end pulled with a force of ranging magnitude. The values of force and the extension were recorded as in the table below:-

Force (N)	0	0.20	0.55	0.75	1.00	1.30	1.40
Extension(cm)	0	1.5	2.5	3.5	4.5	6.0	7.0

(i) Plot a graph of force (Y axis) against extension (X-axis) on the grid provided

(5m)

(i) From the graph, determine the spring constant of the rubber within elastic limit

(ii) What is the size of force at the elastic limit

(2mks)

(c) Three identical springs A, B and C of negligible weight are connected as shown below.

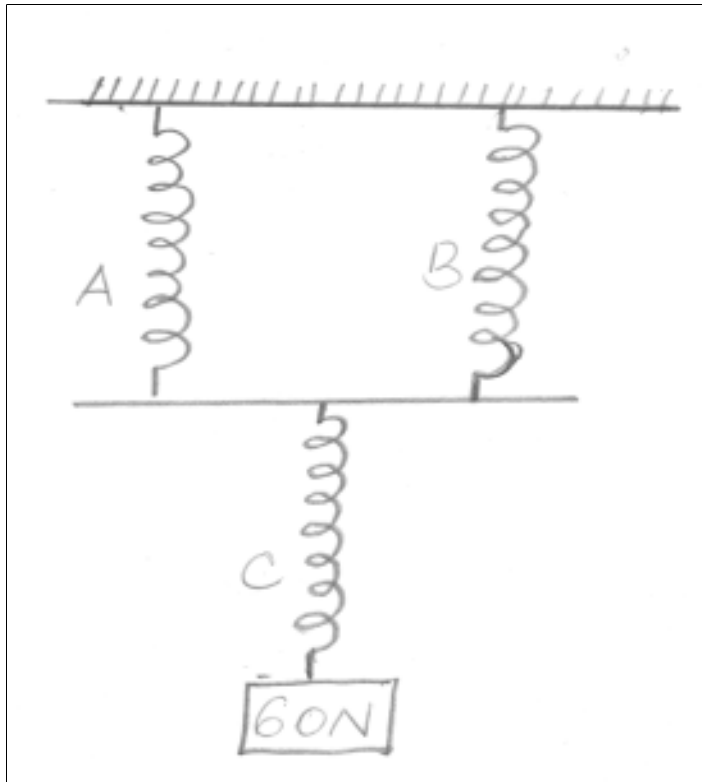

The springs support a load of 60N. If the spring constant of each is 150N/m , determine the total extension of the springs (3mks)

14. (a) State the Pascal's principle (1mk)

(b) The height of a mercury barometer at a particular place is 70cm. given that the density of mercury is 13600kgm^{-3} , determine;

(i) The atmospheric pressure at the place. (3mks)

(ii) The height of a water barometer at the same place. (Density of water= 1g/cm^3) (2mks)

(iii) Give a reason why mercury is preferred as a barometric liquid. (1mks)

(c) Calculate the minimum pressure a block of dimensions $3\text{cm} \times 10\text{cm} \times 15\text{cm}$ and mass 12kg could exert on a horizontal surface. (3mks)

15. (a) In an experiment to determine the diameter of an oil molecule, an oil drop of radius 0.02cm was placed in a tray of water in which lycopodium powder had been sprinkled oil drop spread to a circular patch of radius of 0.2cm

Determine

- (i) The volume of the oil drop (2mks)
- (ii) The area of the patch (2mks)
- (iii) Diameter of the oil molecule (3mks)

(b) state two assumptions made in the experiment above. (2mks)

16. (a) What property of light is suggested by the formation of shadows? (1mk)

(b) A building standing 200m from a pinhole camera produces on the screen of the camera an image 2.5cm high 5.0cm behind the pinhole.

Determine the actual height of the building (3mks)

(c) An object of height 2.0cm is placed 5.0cm in front of a convex mirror of focal length 10.0cm

(i) On the grid provided, draw to scale a ray diagram to locate the position of the image. (4mks)

(ii) Calculate the magnification produced by the mirror. (2mks)

17. (a) State the principle of moments (1mk)

(b) The figure below shows a uniform metre rule of mass 300g acted upon by a number of forces.

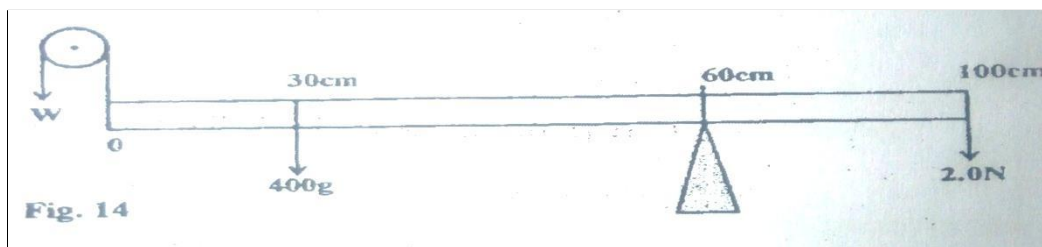

Determine;

(i) Sum of clockwise moments (leave your answer in terms of W) (2mks)

(ii) Sum of anticlockwise moments (2mks)

(iii) The force W (2mks)

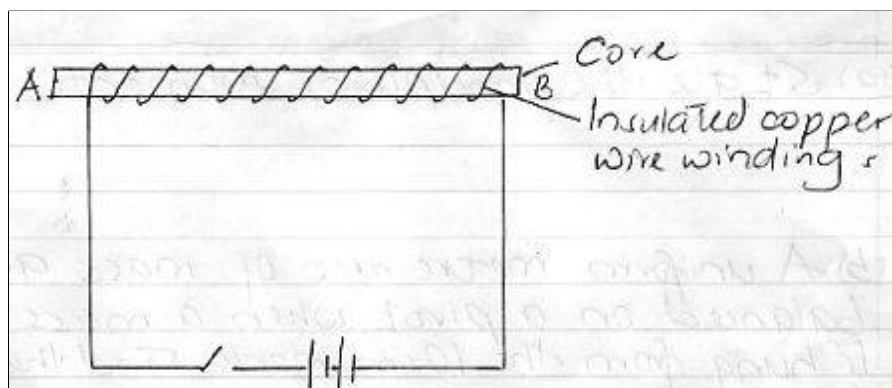

18. The figure below shows an electromagnet

- (i) Explain why the cord is made up of iron and not steel (2mks)
- (ii) On the same diagram indicate the direction of the current flow when the switch is closed (1mk)
- (iii) When current is allowed to flow, the electromagnet becomes magnetized. Identify the poles of the magnet (2mks)
- A. _____
- B. _____
- (iv) State three factors that affect the strength of the electromagnet (3mks)

ASSIGNMENT TWO

1. State the basic law of magnetism (1mk)
2. The figure below shows a micrometer screw gauge being used to measure the diameter of a Bearing

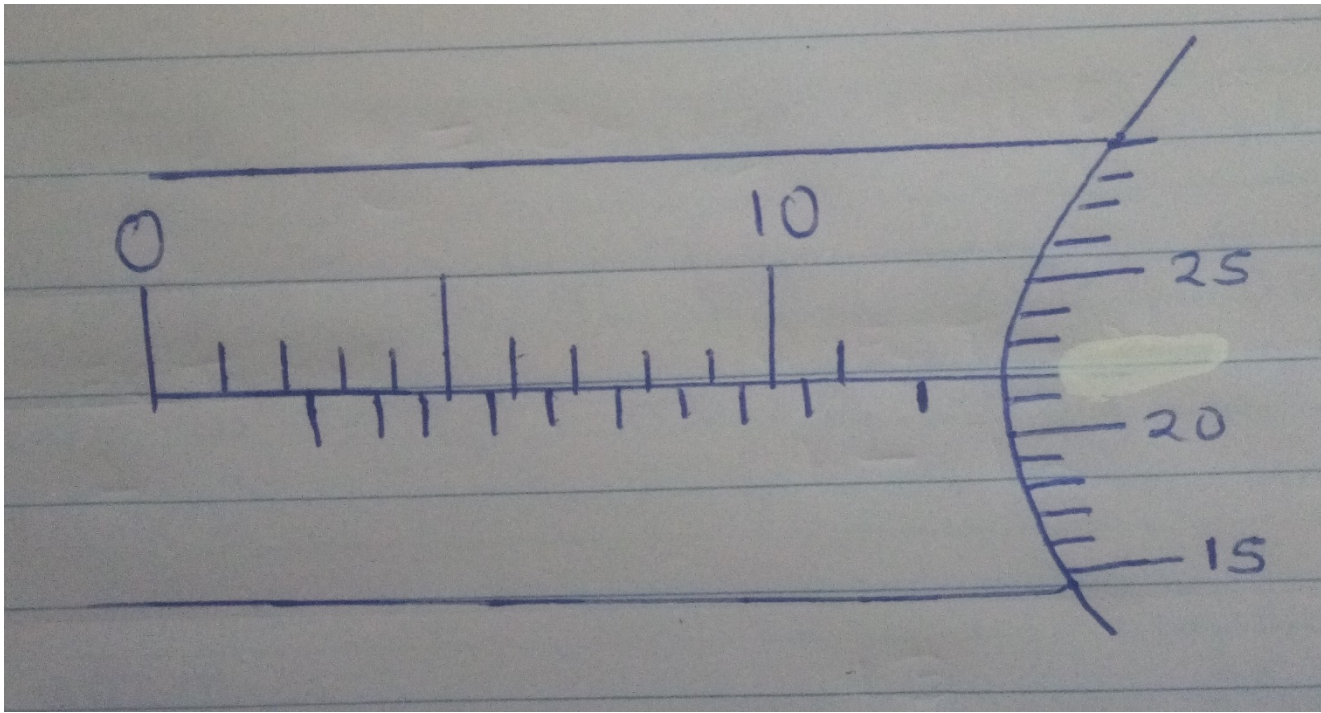

The thimble scale has 50 divisions. What is the reading?

(2mks)

3. The figure below shows a uniform metal rod balanced at its centre by different force.

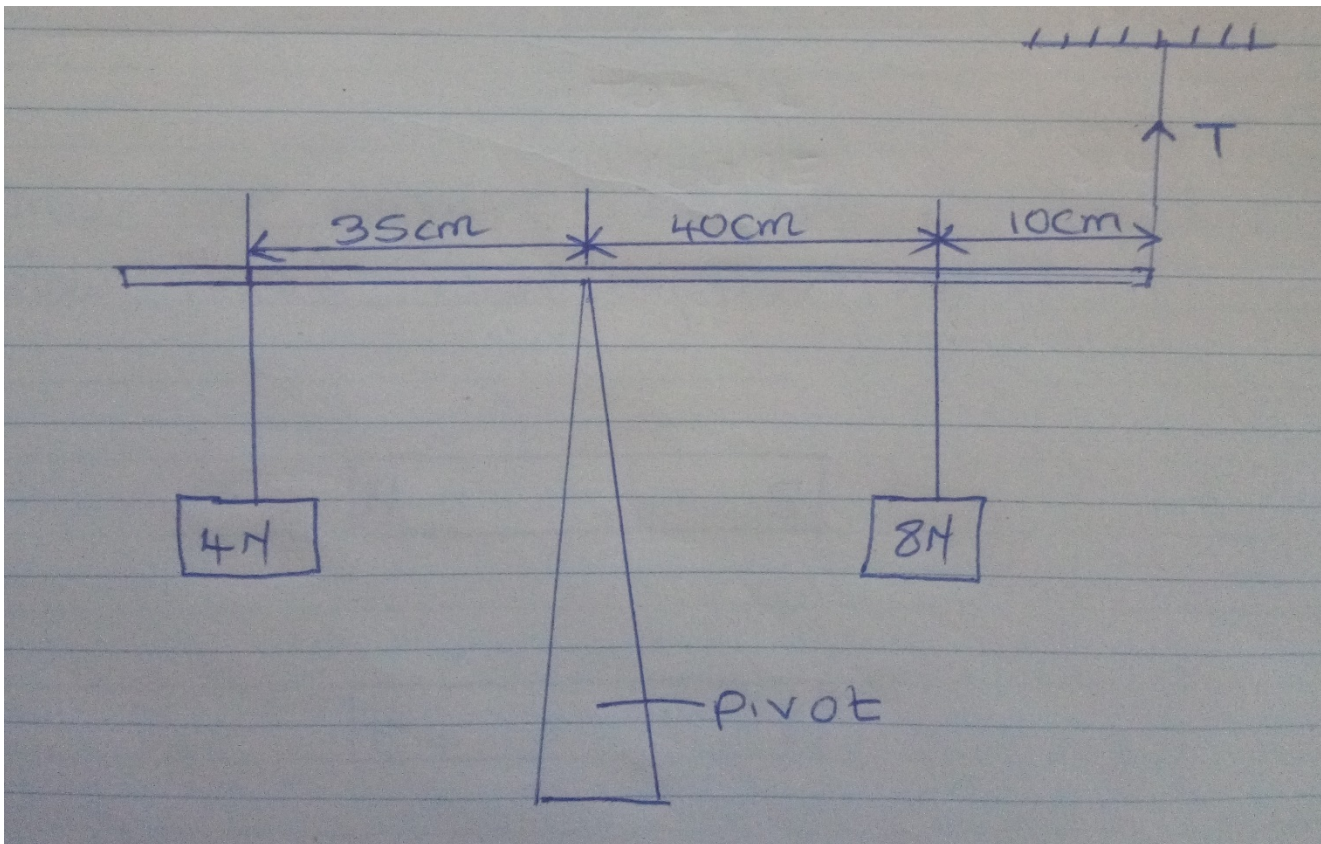

Determine the value of T

(3mks)

4. Give two reasons why when alighting from a moving bus a person has to spread out his legs.(2mks)

5. A uniform metal bar, 100 cm long balances at 20 cm mark when a mass of 1.5kg is attached at 0 cm mark.

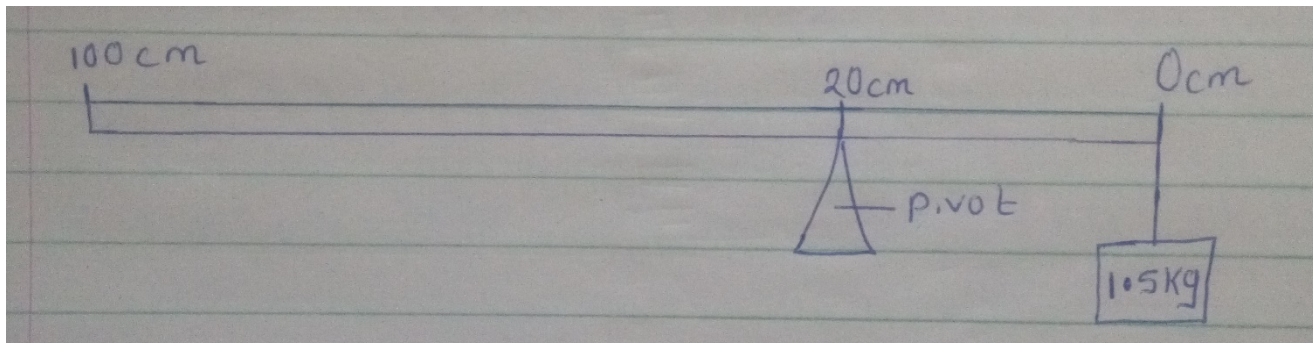

Calculate the weight of the bar ($g = 10 \text{ N/kg}$)

(3mks)

6. Draw the magnetic field pattern of the two magnets below placed close together.

(2 mks)

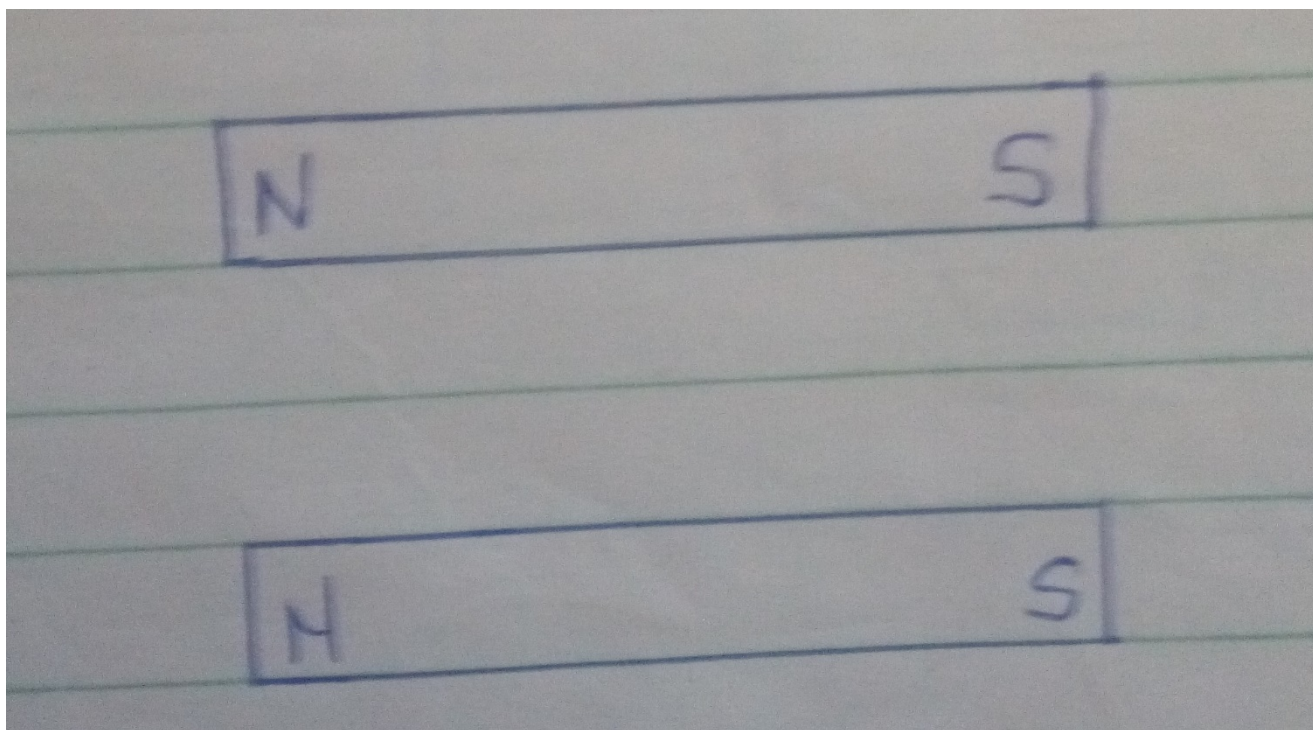

7. Define polarization

(1 mk)

8. Give 2 uses of an electroscope.

(2 mks)

9. At what angle would two mirrors be inclined to form 17 images.

(2 mks)

10. What does formation of shadows show about light?

(1mk)

11. Explain why soft -board ceiling is better than concrete ceiling.

(1 mk)

12. The figure below shows water in a flask

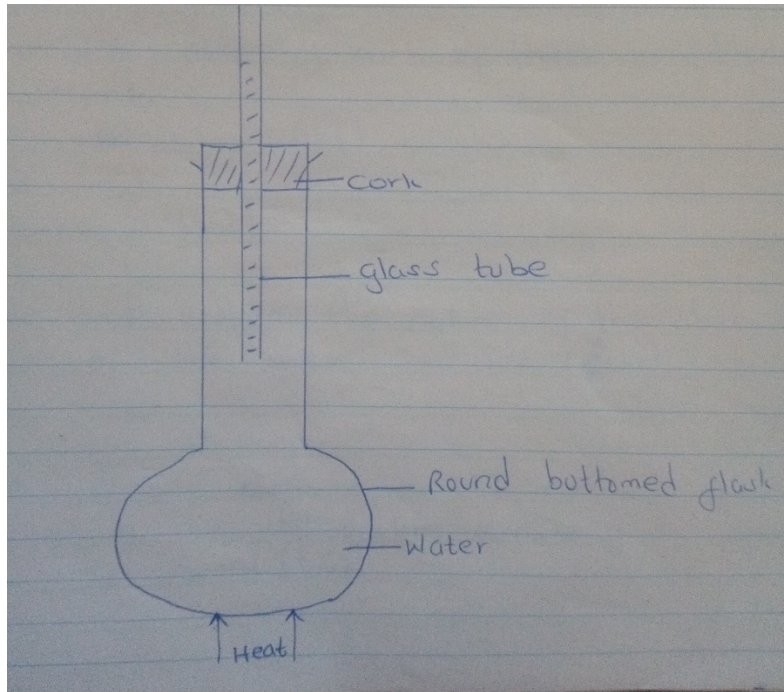

As it is heated, it is observed that the level of water in the glass tube falls slightly first then later starts

Rising. Explain

(2mks)

13. A) State the kinetic theory of matter

(1mk)

b) Brownian motion of smoke particles can be studied by using the apparatus shown in the figure below.

To observe the motion some smoke is closed in the smoke cell and then observed through the Microscope.

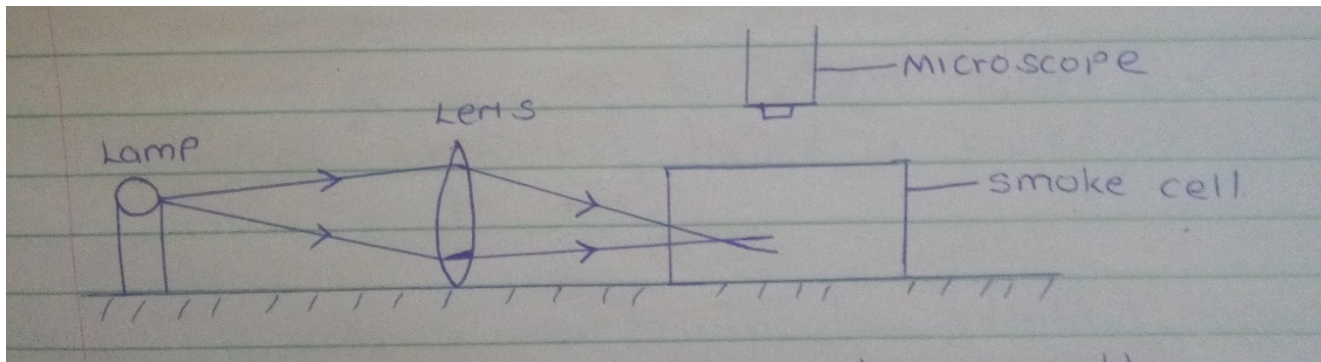

Explain the role of each of these in the experiment.

- i) Smoke particle (1 mk)
- ii) Lens (1 mk)
- c) State and explain the nature of the observed motion of the smoke particles. (2mks)
- d) What will be observed on the motion of smoke particles if the temperature surrounding the smoke cell is raised. (1mk)

14. The figure below shows a cross section of a vacuum flask.

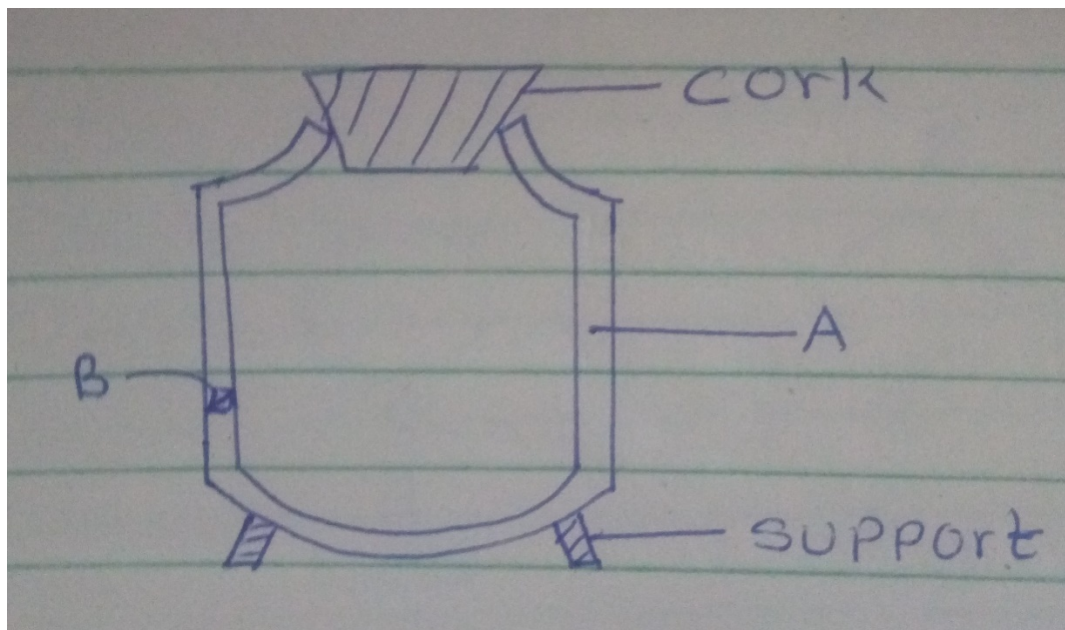

- a) Name parts, labeled. (2mks)

B) Boiling water is poured into two identical vacuum flasks A and B. Flasks A is partially filled while Flask

B is completely filled. Both are closed tightly. State with reasons the flask in which water is likely to have a higher temperature eight hours later. (2mks)

15. a) An uncharged metal rod brought close but not touching the cap of a charged electroscope causes a decrease in the divergence of the leaf. Explain. (2mks)

b) A positively charged rod is brought close to two spheres A and B, held by insulated handles as shown below.

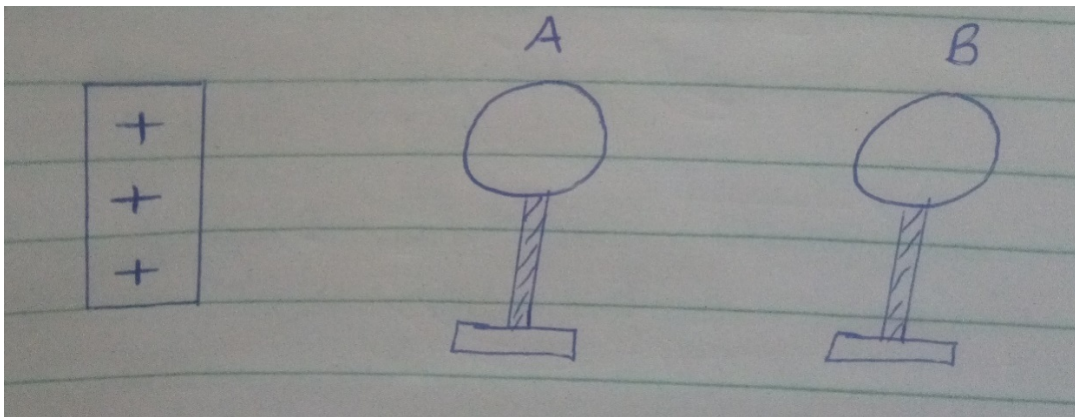

Indicate the charge on sphere A and B.

(2mks)

c) The figure below shows a highly positively charged rod being moved slowly downwards towards the cap of a negatively charged leaf electroscope. It is observed that the leaf initially falls then rises.

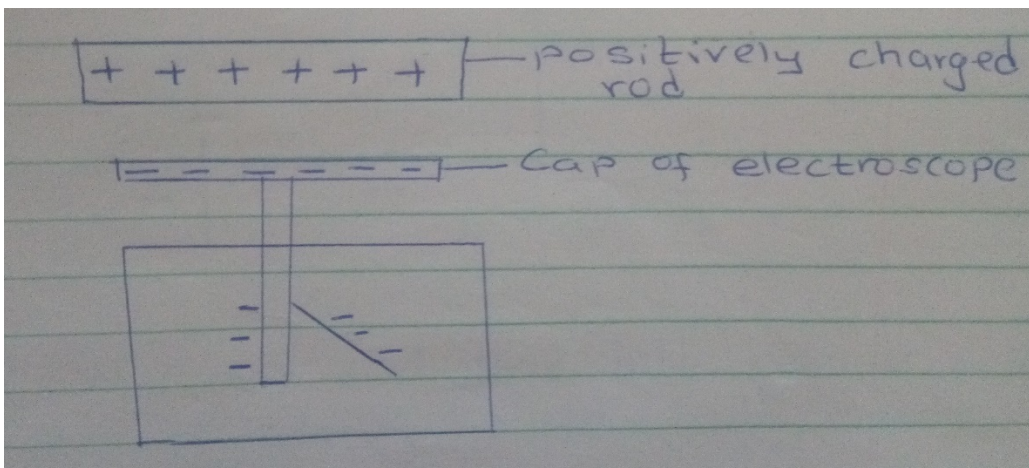

Explain this observation.

(2mks)

16. a) State the right – hand grip rule.

(1mk)

b) State and explain the functions of the keeper in storing magnets.

(2mks)

c) The figure below shows a steel bar to be magnetized

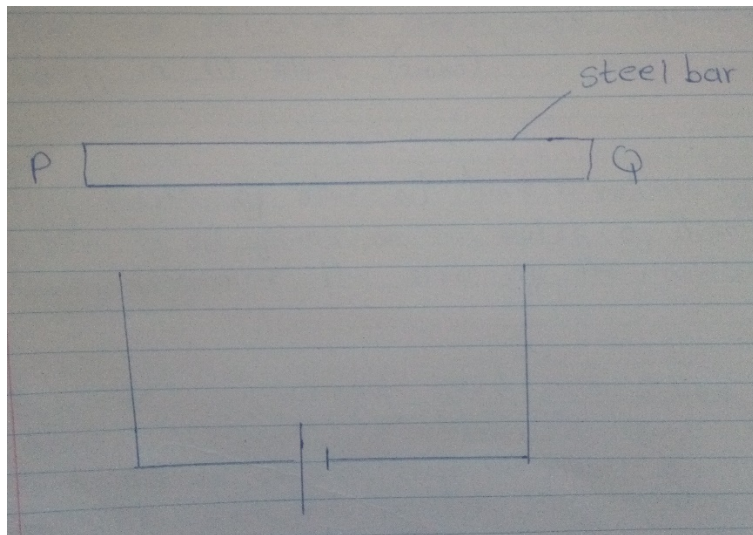

Complete the circuit such that both poles P and Q acquire opposite polarity (North – South respectively)

(2 mks)

d) Name 2 methods of magnetization of a magnetic material.

(2mks)

17. a) A micrometer screw gauge which had an error of +0.02mm was used to measure the diameter of a spherical marble. If the actual diameter was 3.67mm

i) What was the reading indicated on the instrument.

(2mks)

ii) Draw the micrometer screw gauge showing that reading in (i) above.

(2mks)

b) Fifty drops of olive oil have a volume of 1.0cm^3 . If a drop of oil forms an oil patch of diameter 20 cm, determine the size of the molecule.

(3mks)

c) A burette was initially filled with a liquid of density 0.8g/cm^3 to 12ml. The liquid is allowed to run out for some time. If the volume of liquid removed from the burette has a mass of 14g. Determine the final reading on the burette.

(3mks)

18. a) State the principal of moments

(1 mk)

b) The figure below shows a uniform metre rule pivoted and supported as shown. If the mass of the rule is 2.4kg, Find the distance X.

(3mks)

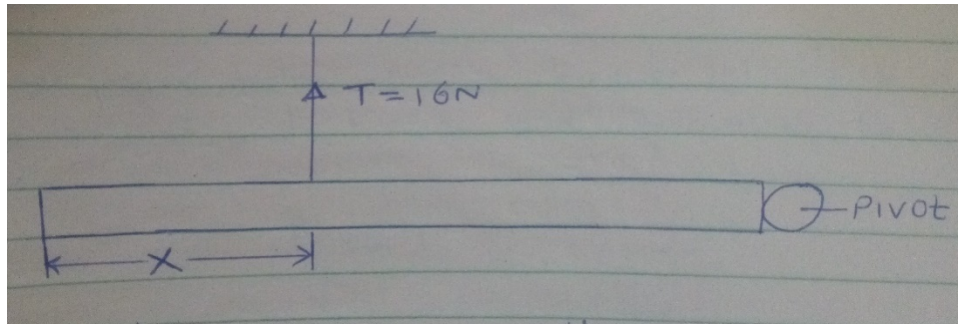

c) A solid weighs 18.5 N on the surface of the moon.

The force of gravity on the moon is 1.7 N/kg . Determine the mass of the solid. (3mks)

19. Taking the density of water as 1000 kg/m^3 and atmospheric pressure as $103,000\text{ N/m}^2$,

Determine the pressure of the gas used. (3mks)

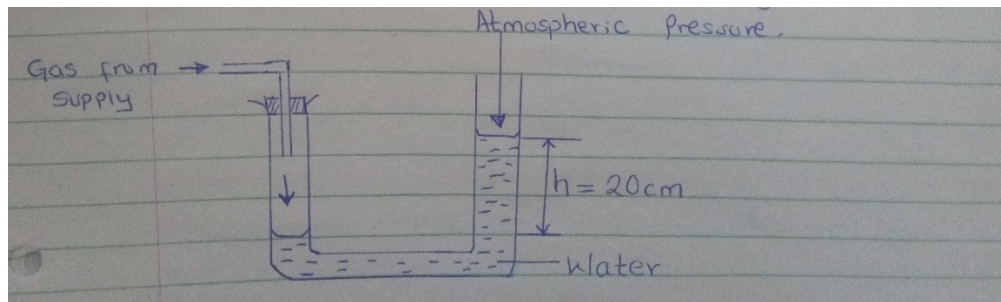

b) State 2 factors that affect the pressure in liquids. (2mks)

c) The figure below show a hydraulic lift. If $A_1 = 0.25\text{ m}^2$, $A_2 = 10\text{ m}^2$ and F_1 is 100 N . Determine F_2 .

(3mks)

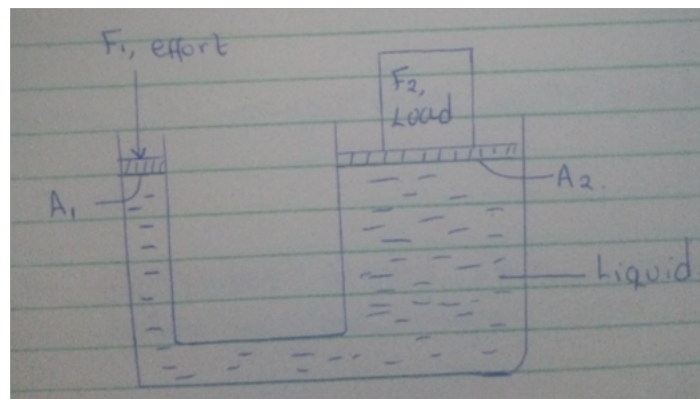

20. a) Differentiate between luminous and non-luminous sources of light. (1mk)

b) Differentiate between transparent and translucent objects. (1mk)

c) The figure below shows a pinhole camera.

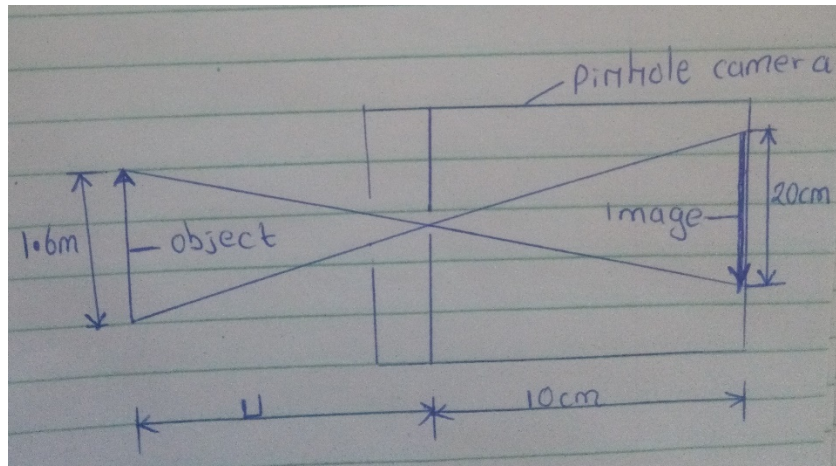

i) At what minimum distance from pinhole must an object stand if a full length image is required.

(3mks)

ii) Determine the magnification of the image.

(2mks)

iii) From the magnification obtained above comment on the nature of the image.

(1mk)

ASSIGNMENT THREE

1. The figure below shows a scale which is part of vernier calipers. What is the reading indicated by the scale?

(2mks)

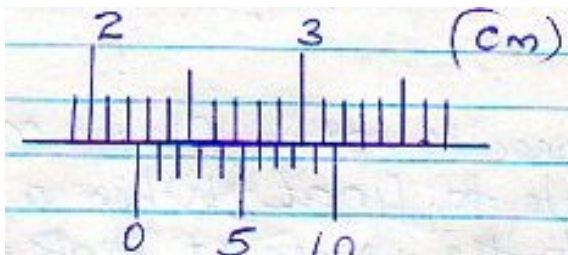

2. The level of liquid in a burette is 32.0cm^3 . If 15 drops each of volume 0.15cm^3 are allowed to fall out of the burette, what is the new level of the liquid? (2mks)

3. The diagram below shows the behavior of mercury in a capillary tube. Explain this observation

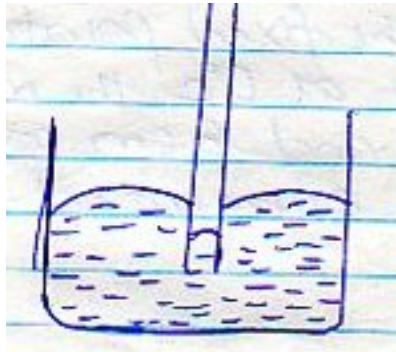

(3mk)

4. A body weighs 600N on the surface of the earth and 450N on the surface of another planet. Calculate the value of g in that planet (g on the earth = 10N/Kg) (3mks) 1
5. A steel needle when placed carefully on water can be made to float. When a detergent is added to the water it sinks. Explain this observation (2mks)
6. Distinguish between the three states of matter in terms of particle spacing and kinetics (3mks)
7. When marking the fixed points on a thermometer it is observed that at 0°C , the mercury thread is of length 1cm and 6cm at 100°C . What temperature would correspond to a length of 4cm? (3mks)

8. The micrometer screw gauge below has a zero error of -0.19mm 2

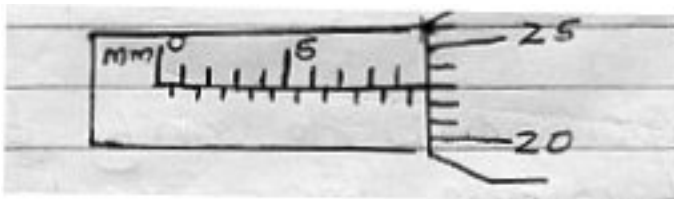

Determine the actual thickness of the object.

(2mks)

9. Distinguish between hard magnetic material and a soft magnetic material (2mks)
10. Describe a simple experiment to show that pressure in liquids increases with depth (3mks)
11. (a) State Hooke's law (1mk)
- (b) In an experiment to verify Hooke's law, a piece of rubber was fixed to a rigid support and the other end pulled with a force of ranging magnitude. The values of force and the extension were recorded as in the table below:-

Force (N)	0	0.25	0.50	0.75	1.00	1.25		
Extension(cm)	0	1.5	2.5	3.5	4.4	6.0		

- (i) Plot a graph of force (Y axis) against extension (X-axis) on the grid provided (5mks)
- (ii) From the graph, determine the spring constant of the rubber within elastic limit (3mks)
- (iii) What is the size of force at the elastic limit (2mks)
- (c) Three identical springs A, B and C of negligible weight are connected as shown below.

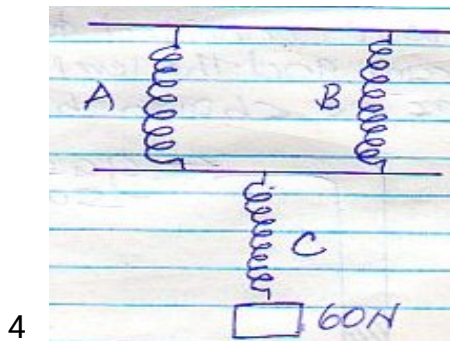

The springs support a load of 60N. If the spring constant of each is 150N/m, determine the total extension of the springs (3mks)

- 12 (a) State the Pascal's principle (1mk)

(b) part of a

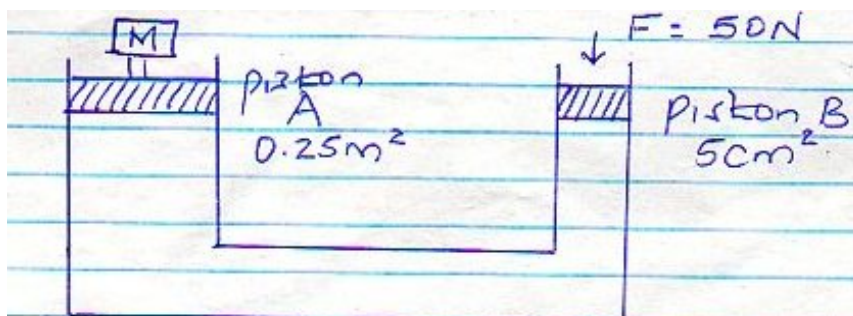

The diagram below shows hydraulic lift

Determine the value of M, the load that could be lifted using this system (3mks)

- (c) A gas supply was connected to U – tube containing mercury and the level of mercury in the tube was as shown below

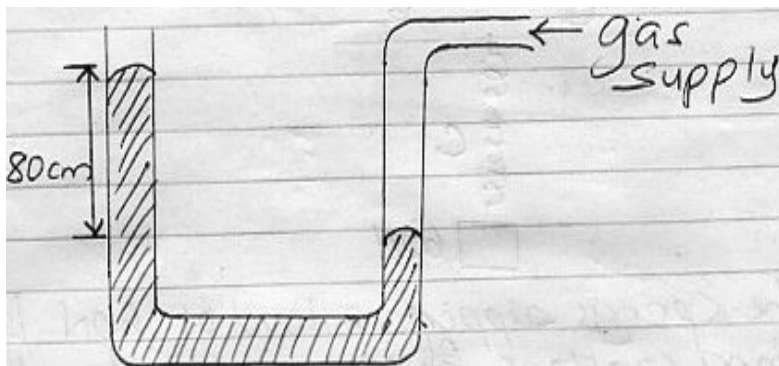

Given that the density of mercury is 13.6g/cm^3 and that atmospheric pressure is $1 \times 10^5\text{Nm}^{-2}$.

Determine the pressure of the gas in Nm^{-2} (3mks)

5

13. (a) The set up below is used to demonstrate Brownian motion using smoke particles

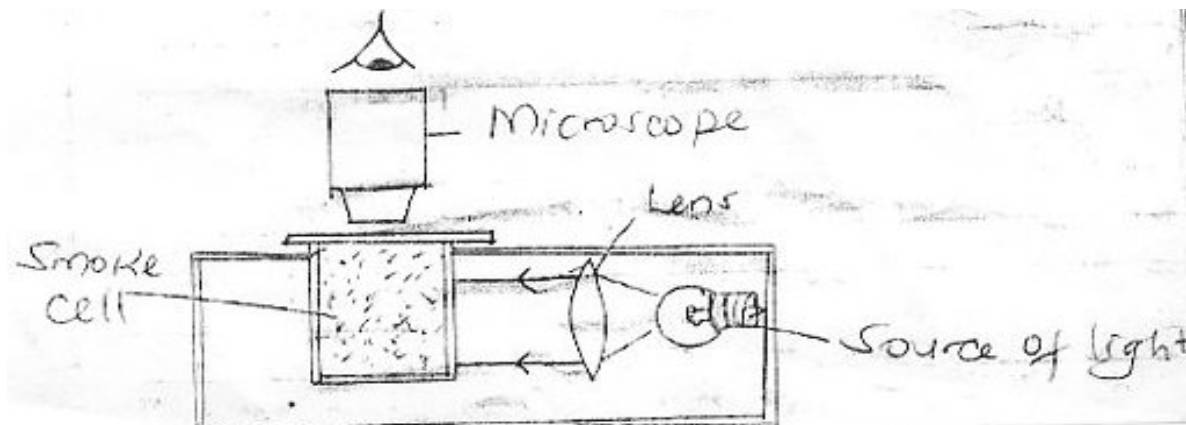

- (i) What is the purpose of the lens? (1mk)
- (ii) Describe the motion of the smoke particles as observed through the microscope (1mk)
- (iii) Explain how the motion in (b)(ii) occurs (2mks)
- (iv) What would be observed in the motion in (b) (iii) if the temperature in the smoke cell is increased (1mk)

6

(b) In an experiment to determine the diameter of an oil molecule, an oil drop of radius 0.02cm was placed in a tray of water in which hydrophobic powder had been sprinkled. The oil drop spread to a circular patch of radius of 0.2cm

Determine

- (i) The volume of the oil drop (2mks)
- (ii) The area of the patch (2mks)
- (iii) Diameter of the oil molecule (3mks)

14. (a) What property of light is suggested by the formation of shadows? (1mk)
- (b) A building standing 200m from a pinhole camera produces on the screen of the camera an image 2.5cm high 5.0cm behind the pinhole. Determine the actual height of the building (3mks)

- (c) An object of height 2.0cm is placed 5.0cm in front of a convex mirror of focal length 10.0cm
- (i) Draw to scale, a ray diagram to locate the position of the image (3mks)
On the grid provided.
 - (ii) Calculate the magnification produced by the mirror. (3mks)

15. (a) State the principle of moments (1mk)
- (b) A uniform metre rule of mass 95g is balanced on a pivot when a mass of 5g is hung from the 10cm mark. Find the position of the pivot (3mks)

- (c) A uniform metre rule pivoted at the 60cm mark is kept horizontally by placing a 50g mass on the 80cm mark. Calculate the mass of the metre rule (3mks)

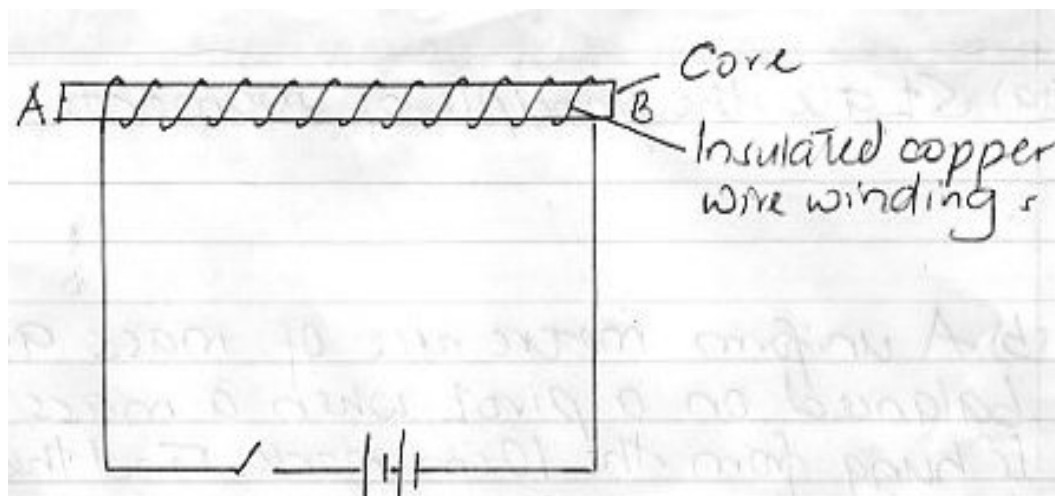

16. The figure below shows an electromagnet

- (i) Explain why the cord is made up of iron and not steel (5mks)
- (ii) On the same diagram indicate the direction of the current flow when the switch is closed (1mk)
- (iii) Whether current is allowed to flow, through the electromagnet it is magnetized. Identify the poles of the magnet (2mks)
- A. _____
- B. _____
- (iv) State three factors that affect the strength of the electromagnet (3mks)

ASSIGNMENT FOUR

1. Study the arrangement and answer the questions that follow.

A and B are identical rubber strips and each has an elastic constant of 50Nm^{-1} . C has an elastic constant of 100Nm^{-1} .

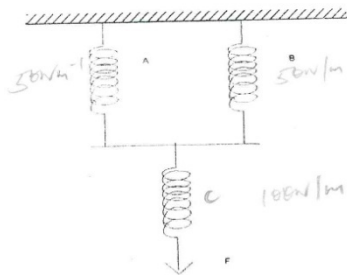

- a) If C extends by 4 cm, by how much would A extend? (2 mks)
- b) Determine the force F, which would cause these extensions. (2 mks)

2. State two factors that affect the turning effect of a force. (2 mks)

3. The figure below shows a u-tube manometer containing oil of density 0.9g/cm^3 . One end is connected to a gas tap.

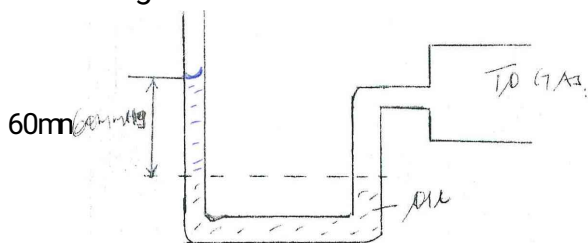

If atmospheric pressure is 1.0×10^5 pa, find the pressure of the gas. (3 mks)

4. State two advantages of an alkaline cell over a lead-acid cell. (2 mks)
5. Three forces 12N due East, 4N due South and 15N due West acted on a body. If the body was in equilibrium, find the resultant force. (2 mks)
6. Explain the following observation. A balloon, when rubbed on a blazer, it sticks to the ceiling board. A block measuring 20cm by 10cm by 4cm rests on a flat surface. The block has a weight of 6N. determine;
(i) The minimum pressure it exerts on the surface. (2 mks)
(ii) The density of the block in kg/m^3 . (3 mks)
7. The figure below shows a uniform cardboard in the shape of a parallelogram. Locate the centre of gravity of the cardboard. (1 mk)
8. (a) What is an electromagnet? (1 mk)
(b) Name the polarity of ends P and R on the diagram below, when the current is switched on

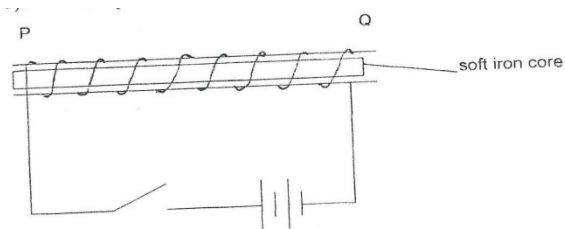

P and Q (1 mk)

9. The figure 4 below shows a ray of light incident on the surface of a plane mirror. The mirror is now rotated clockwise through an angle of 10° . Find the angle between the incident and the reflected rays. (1 mk)
10. The force on a current carrying conductor in a magnetic field can be varied by changing among other, the magnetic field strength and magnitude of the current. Name two other factors that cause the force to vary. (2 mks)
11. (a) Sketch a diagram of micrometer screw gauge with the reading of 12.25 mm (2 mks)
(b) The oil level in a burette is 10.0cm^3 . 5000 drops of the oil are run off the burette. If the radius of 1 drop is 0.7 mm
(i) Calculate the volume of one drop. (2 mks)
(ii) What is the final reading of the burette. (1 mk)
(c) The oil was made to spread on a surface of water forming a circular patch of diameter 21.0 m
(i) Calculate the area of the oil patch. (2 mks)
(ii) Calculate the thickness of the oil molecule. (2 mks)
(d) State one assumption made in c(ii) above. (1 mk)

12. (a) State the Fleming's left hand rule. (1 mk)

(b) Sketch the resultant field pattern around the following current carrying conductor and show the direction of the forces acting on the conductors.

(i) Current flowing into the paper. (1 mk)



(ii) Current flowing out of the paper. (1 mk)



(c) The diagram below shows an electric bell.

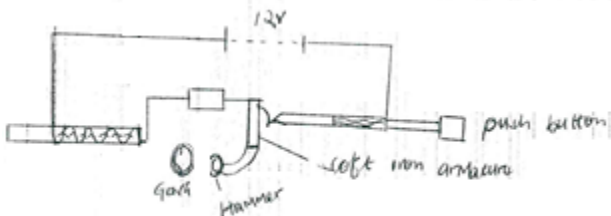

(i) Describe how the electric bell works. (4 mks)

(ii) Explain what would happen if the armature is made of steel. (1 mks)

(iii) What adjustment should be done to the system to make it operate effectively with a lower voltage battery. (1 mk)

13. (a) Differentiate between a real image and a virtual image. (1 mk)

(b) An object of height 10cm is placed 5cm in front of a concave mirror of focal length 10cm.

(i) By use of ray diagram shows the location of the image on the grid provided (4 mks)

Use the ray diagram in (i) above to determine the

(ii) Image distance (2 mks)

(iii) Magnification (3 mks)

(c) State the reason why convex mirror is used as a driving mirror instead of plane mirror. (1 mks)

14. (a) State Hooke's law. (1 mk)

(b) A spring with the upper end fixed, hang vertically and several masses are suspended from its lower end one at a time. The readings were recorded as shown.

Mass in kg	0	0.02	0.04	0.06	0.08	0.10
Extension mm	0	11	9	29	41	51
Force N						
Extension in m						

(i) Fill in the table. (2 mks)

- (ii) Plot a graph of extension in (m)(y-axis) against force in N. (5 mks)
- (c) (i) From the graph determine the extension of a mass 0.045kg. Give your answer in mm.(2 mks)
- (ii) Determine the spring constant of the spring. (3 mks)
- (d) If two such springs were connected in series, what extension would they show when a mass of 1.5kg hangs from one end. (2 mks)
15. (a) State two advantages of a lead acid accumulator over dry cells. (2 mks)

- (b) The figure below shows a highly negatively charged rod being brought slowly near the cap of a positively charged gold leaf electroscope.

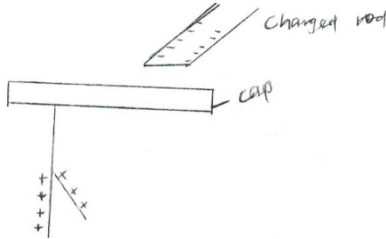

State and explain what will be observed on the leaf of the electroscope. (2 mks)

- (c) The figure below shows how keepers are used to store magnets. (2 mks)

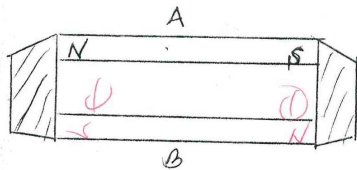

- (i) Mark on the diagram the polarity of the magnet B. (2 mks)
- (ii) Briefly explain how keepers assist in storing magnets. (2 mks)

ASSIGNMENT FIVE

1. A student used the measuring instrument shown below to measure the thickness of a cylindrical wire, If the wire is 10cm long, find the volume of the wire. (3mks)

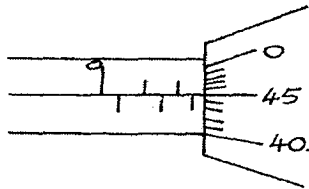

2. The load carried by a truck loader was measured to be 65,000 grams. Convert the mass of the load into milligrams and express the answer in standard form. (2 Marks)
3. A form one girl observed that when mercury is put into a glass it does not wet the glass. Explain the observations made by the girl. (2 Marks)

4. In using the lift pump to raise water from a bore hole. It is observed that practically the height the water is raised cannot be 10m and more. Give two reasons for this observation.(2 Marks)

5. When a mass of 2kg is hang from a single spring, the spring extends by a distance x. Determine the total extension in the set up below. (2 marks)

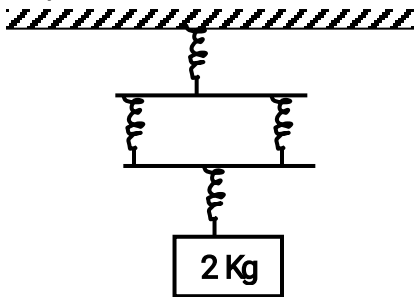

6. (a) State what is meant by streamline flow (1 Mark)

(b) The figure shows the cross section of an aeroplane wing, with the aeroplane moving in the direction shown by the arrow.



Sketch streamlines to show how air flows past the wing as the aeroplane moves (1 Mark)

(c) The diagram below shows two horizontal pipes, A and B. Tube A contains liquid at rest while tube B contains liquid in motion.

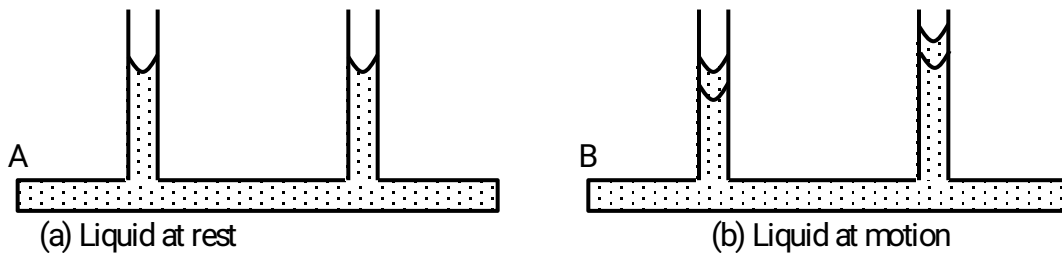

(i) Sketch graphs for (a) and (b) to show variation in pressure (2 Marks)

7, Explain why ethylated spirit at room temperature when dropped at the back of the palm makes the palm to feel very cold. (2 Marks)

8. A block measuring 20cm by 10cm by 4 cm rests on a flat surface. The block has a weight of 6.0N. Determine:

(a) The minimum pressure it exerts on the surface. (2 Marks)

(b) The density of the block in kg/m^3 . (2 Marks)

Take ($g = 10\text{N/kg}$)

9. (a) State the kinetic theory of matter. (1 Mark)
 (b) Why is smoke preferred for use in the smoke cell experiment? (2 marks)
 (c). Explain the cause of random motion of smoke particles as observed in Brown Motion experiment using a smoke cell (3mks)

10. In the figure 2 below shows a uniform bar of length 1.0M pivoted near one end. The bar is kept in equilibrium by a spring balance shown.

Figure 2

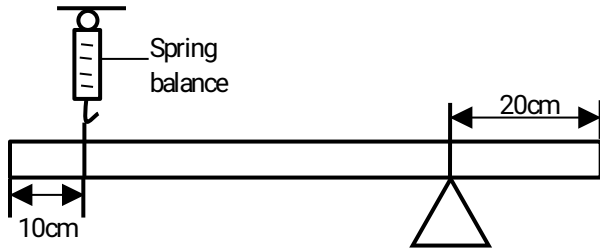

Given that the weight of the metre bar is 1.4N, determine the reading of the spring balance. (3 Marks)

- 11 .State the property of light associated with formation of shadows (1mk)
 12. .Explain why soft iron keepers are suitable for storing magnets (2mks)
 13.Fig 1 below shows a conductor carrying current placed in the magnetic field of two magnets. Complete the diagram by showing the field pattern and the direction of force F that acts on the conductor

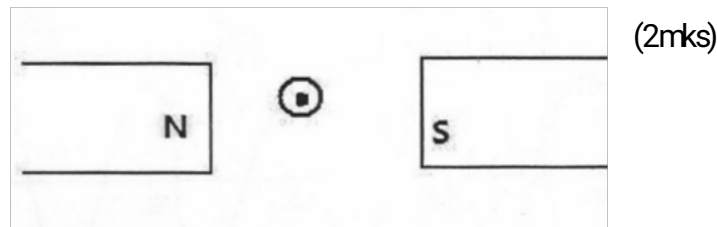

Figure 1

- 14.State two quantities that are used to determine whether accumulator require recharging or not (2mks)
 15.The figure 2 below shows the image I, formed in a convex mirror. Complete the ray diagram to show the position of the object. (2mks)

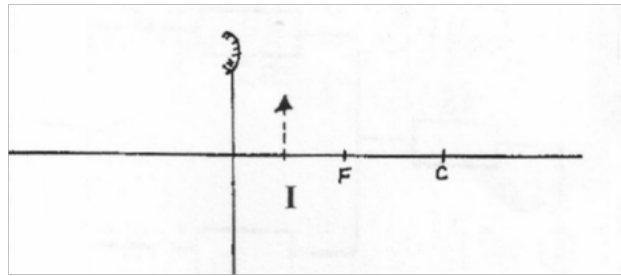
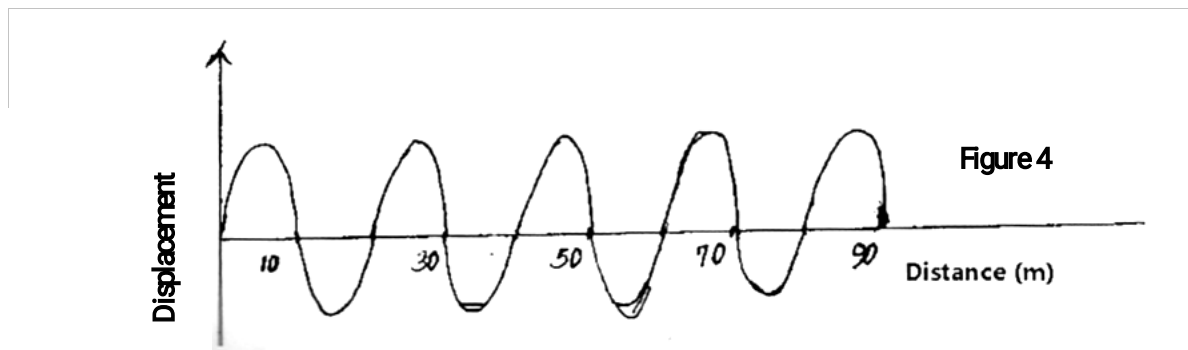

Figure 3

16. The figure below shows a displacement –time graph for a wave with a period of 0.5 seconds



Calculate the velocity of the wave

(2mks)

17. The figure below shows part of a burette scale after 200 drops of olive oil were run out.

The initial reading of the volume was 15.5ml



- a) Determine the volume of 200 drops.

(3 marks)

b) When a single drop was allowed to spread on a careful prepared water surface it made a circular patch of diameter 31.0cm Use this information to determine;

- i) The area of the patch.(3 marks)
 - ii) An estimate for the length of the olive oil molecules to three significant figures.(3 marks)
 - c) State **one** necessary assumption for the calculation in b(ii) above. (1 mark)
18. State any **two** differences between image formed by plane mirror and pinhole camera (2 marks)
19. The diagram below shows a positively charged rod brought close to two metal spheres on insulating stands.

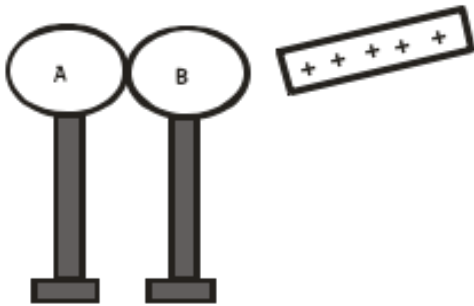

Describe how you would use the rod to charge the two spheres differently. (2 marks)

20. State **two** defects of a simple cell and how each can be corrected. (2 marks)
21. Figure 2 below shows two bar magnets holding steel pins and placed side by side.

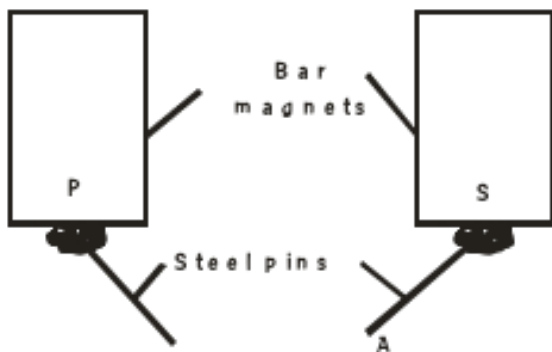

Identify the polarities of:

(2 marks)

A

P

22. .(a) One the axis provided, sketch a graph of volume against temperature of water from 0° to 20°C. (2mks)

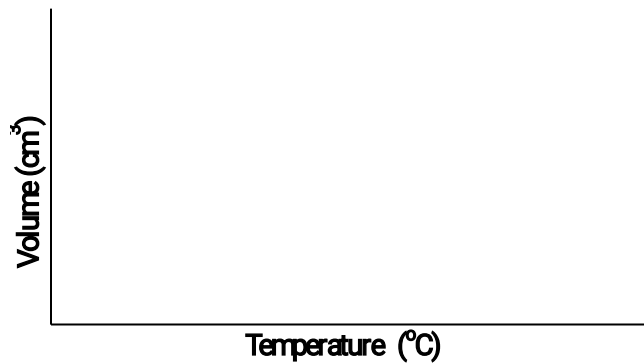

(b) During anomalous expansion of water, heat transfer is limited to conduction and radiation only explain

A student stands at a distance 400m from a wall and claps two pieces of wood. After the first clap, the student claps whenever an echo is heard from the wall. Another student starts a stopwatch at the first clap and stops it after the twentieth clap. The stopwatch records a time of 50 seconds. Find the speed of sound. A lawn sprinkler has 40 holes, each of cross-section area $2.0 \times 10^{-2} \text{ cm}^2$. It is connected to a hose-pipe of cross-section area 1.6 cm^2 . If the speed of the water in the hose-pipe is 1.2 ms^{-1} , calculate:

- a) The flow rate in the hose-pipe (2 mks)
- b) The speed at which water emerges from the holes.(3 mks)

ASSIGNMENT 6

1. The figure below shows the scale of a vernier callipers which was being used to measure the internal diameter of a tin. The vernier callipers has a zero error of 0.22 cm

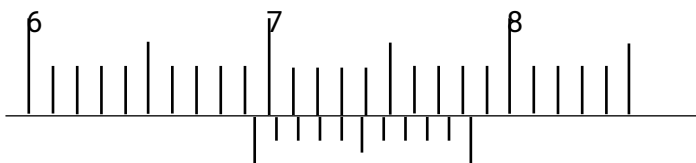

- (a) Record the actual diameter of the tin. (3 marks)
 - (b) State one advantage of the above measuring instrument over a micrometer screw gauge. (2 marks)
2. State the Pascal's Principle of transmission of pressure in fluids. (2 marks)
3. The figure below shows an iron bar being magnetized with a magnet.

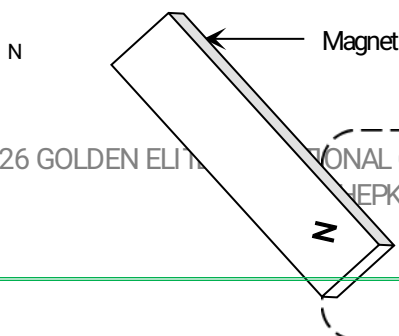

s

- (a) Identify the magnetization method being used. (1 mark)
- (b) Name the polarities X and Y of the resulting magnet. (2 marks)

4. The diagram below shows a steel rod **AB** inside a solenoid.

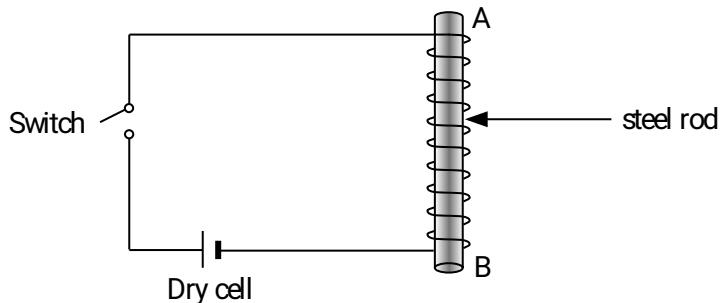

- (i) What is the name of the above method of magnetization? (1 mark)
- (ii) Give the polarities of ends A and B when the switch is put on. (2 marks)

5. An object of mass 120g, when half immersed in water displaced a volume of 20cm^3 , calculate the density of the object? (3 marks)

6. An umbrella is made of cloth but it will not allow rain to pass through it. Explain?

7. (a) A battery is rated 70AH, giving a practical example, explain the meaning of the rating?

(b) A certain battery drives a current of 2A in a circuit for 1 hour. Calculate the quantity of charge in the circuit? (2 marks)

8. The mass of an empty density bottle is **23.2 g**. When full of water its mass is **73.2 g**. Some sand is poured into the empty density bottle and the total mass is **55.2 g**. Water is then added onto the sand in the density bottle until the bottle is full. If the total mass of the bottle and its contents is now found to be **85.2 g**, calculate the density of sand. (Take density of water = 1.0 g/cm^3) (5 marks)

9. On a cold day, the metal handlebars of a bicycle feel colder than the rubber grips. Give a reason for this? (1 mark)

10. Give three ways of increasing the sensitivity of a liquid-in-glass thermometer. (3 marks)

11. The U-tube shown below contains mercury of density 13600 kg/cm^3 and is connected to a laboratory gas supply.

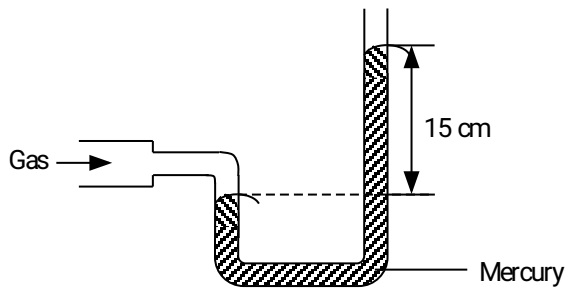

If the atmospheric pressure is 750 mmHg , what is the pressure of the gas in:

- (i) mmHg (2 marks)
- (ii) Pascal. (Take $g = 10 \text{ N/kg}$) (3 marks)
12. A uniform 90 cm rod AB is balanced at its center of gravity, weight Y , 1 N and 2 N are hung 20 cm , 65 cm and 85 cm respectively from A . Calculate the force Y ? (3 marks)
13. A pinhole camera which is 1.5 m long forms an image of the sun which is 7 mm in radius, assuming that the sun is $1.5 \times 10^8 \text{ km}$ away, estimate the diameter of the sun. (3 marks)
14. The diagram below shows a simple Voltaic cell. The flow of current is represented by i . Identify:

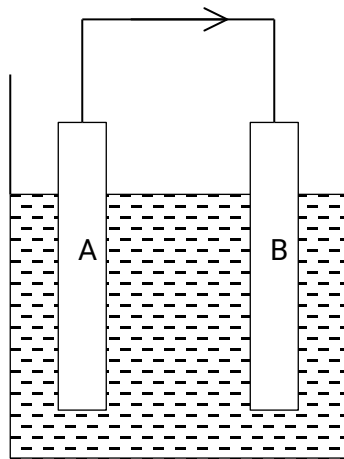

- (i) The Zinc rod (1 mark)
- (ii) The Copper rod (1 mark)
15. In the diagram below the metre rule is uniform and has a mass of 100 g

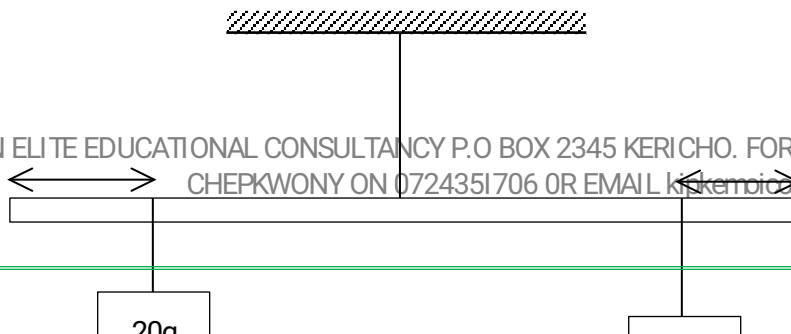

20cm

10cm

(a) If the rule is perfectly balanced, determine the mark on the metre rule at which the string is tied.

(4 marks)

(b) What upward force in does the string exert on the rule?

(3 marks)

16. Using a ray diagram, locate the images formed in the figure below.

(4 marks)

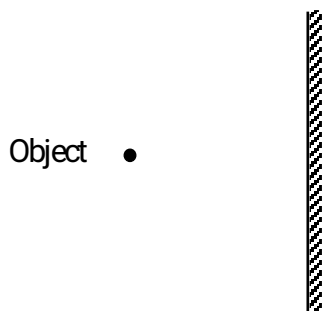

17. The magnetic field between the poles of two permanent bar magnets is shown below. The neutral point is marked X

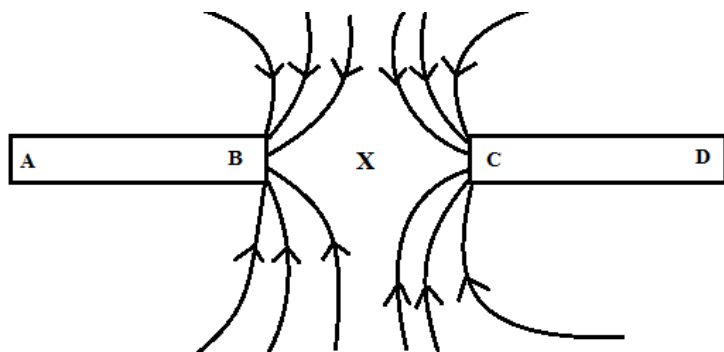

(1 mark)

(a) Explain what is meant by a neutral point?

(1 mark)

(b) Identify the poles marked A, B, C and D.

(2 marks)

(c) Which is the stronger pole? B or C.

(d) Give a reason to your answer in (c) above.

(1 mark)

(e) The two magnets were prepared by a student in a college. Suggest two different methods by which she could have prepared the two magnets.

(2 marks)

(f) Draw the magnetic domains in magnet AB showing clearly the north and south poles.

(2 marks)

A B

(g) (i) State one difference between the magnetic properties of steel and iron. (2 marks)

(ii) Given the two materials state which you would use to make: (2 marks)

a. An electromagnet

b. A compass needle.

18. In an experiment to determine the size of an oil molecule, clean water was placed in a large basin and then left over several minutes without any disturbance. Lycopodium powder was carefully spread on the water surface. A drop of oil was then taken from a container using a fine wire. Its diameter was measured using a millimeter scale with the aid of a hand lens and was found to be 0.35mm. The oil drop was carefully transferred onto the water surface where it spread to form a circular patch of diameter 14cm.

(a) Explain briefly why:

(i) It was important to use clean water for this experiment. (1 marks)

(ii) The water was held in a large basin. (1 mark)

(iii) The water was left undisturbed for several minutes. (1 mark)

(iv) Lycopodium powder was spread over the surface of the water. (1 marks)

(b) Use the measurements obtained to determine:

(i) The volume of oil. (3 marks)

(ii) The area of the oil patch. (3 marks)

(iii) The approximate diameter of an oil molecule. (3 marks)

(iv) The approximate volume of an oil molecule in mm^3 (correct to 3 significant figures)

(v) The number of oil molecules in the oil drop. (correct to 3 significant figures)

Take $\pi = \frac{22}{7}$. (3 marks)

ASSIGNMENT 7

1. Distinguish between mass and weight of a body stating the S.I units for each. (2mks)

2. The figure below shows part of scale of vernier calipers.

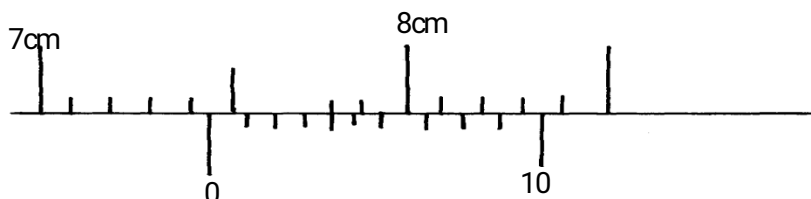

What is the reading indicated on the scale (1mk)

3. 180cm^3 of fresh water of density 100kg/m^3 is mixed with 2200cm^3 of sea water of density 1025kg/m^3 .

Calculate the density of the mixture (4mks)

4. Explain why fish can survive under water when the surface is already frozen (2mks)

5. Two inflated balloons are at the same level while suspended from threads a short distance apart as shown below,

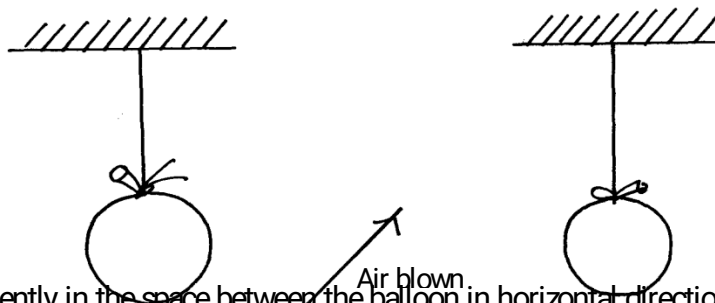

Some air is blown gently in the space between the balloons in horizontal direction. Explain what happens to the balloons. (2mks)

6. State **one** advantage of an alkaline battery over a lead acid battery. (1mk)

7. The diagram below shows a permanent magnet suspended by a spring. State with reason the behaviour of the magnet when the switch is closed. (2mks)

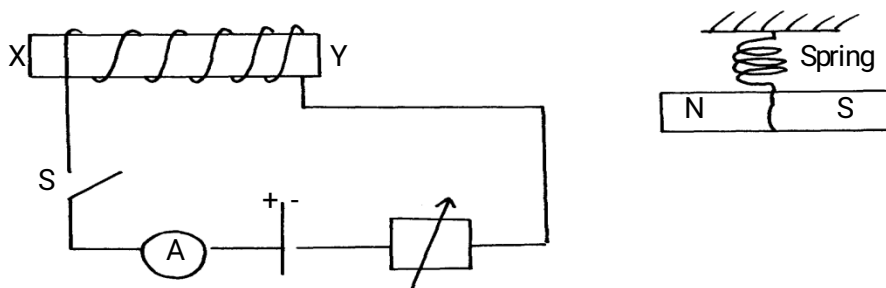

.....
.....

8. Convection and diffusion both involve motion of fluids. Distinguish between the two. (2mks)

.....
.....

A negatively, charged rod is brought close to (but not touching) an uncharged sphere. If the sphere is momentarily earthed and then the rod is removed, briefly explain what happens. (2mks)

.....

9. Indicate on the diagram below, the level of mercury in the tubes X and Y (2mks)

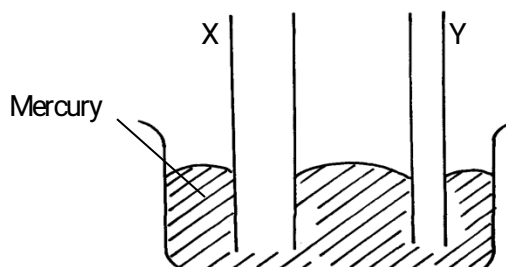

10. An object weighs 1200N on a certain planet. What is the gravitational field strength of this planet if the object is 60kg? (3mks)

11. State **two** properties of a thermometric liquid. (2mks)

12.

a) Define **pressure** and give its S.I nits. (2mks)

b) The diagram below represents a motor car hydraulic braking system;

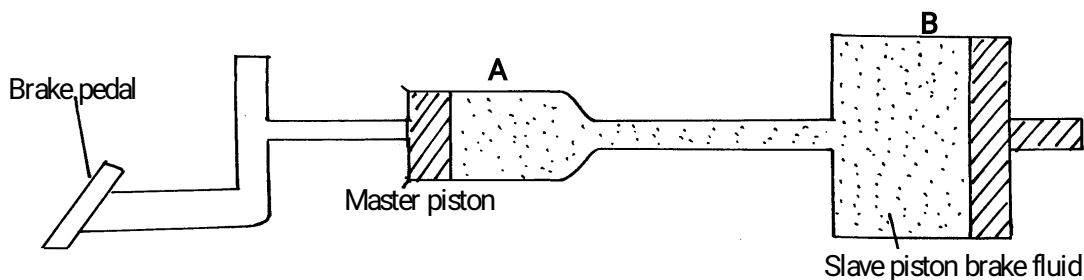

i. State **two** properties of the liquid used as a brake fluid (2mks)

ii. Given that in the diagram (b) above the master piston has an area of 15cm^2 and the slave piston has an area of 50cm^2 a force of 100N is applied on the master piston. Find the force used to stop the car. (3mks)

c) Compare the values of pressure in the two pistons above and give a reason for your

answer.

(2mks)

- d) Give a reason why gas is not suitable for use in place of the brake fluid. (1mk)
- e) $X\text{cm}^3$ of substance A which has density of 800kg/m^3 is mixed with 100cm^3 of water with a density of 1000kg/m^3 . The density of the mixture is 960kg/m^3 . Determine the value of X (3mks)

13.

- a) Give reasons why it is necessary to leave the caps of the cells open when charging an accumulator (1mk)
- b) Define current and state its SI unit (2mks)
- c) A charge of 120 coulombs flow through a 1 am every minute. Calculate the current flowing through the lamp. (3mks)
- d) What do you understand by open and closed circuits? (2mks)

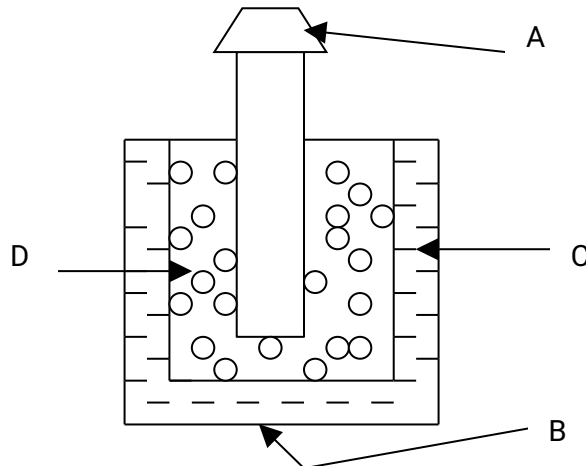

i. State the polarities of A and B. (2 mks)

ii. Name the chemical substances in the parts labeled C and D (2mks)

14.

- a) The figure shows an arrangement of source of light, an opaque object and a screen. Using A, B and C as point sources, sketch on the same diagram labeled a ray diagram to show what is observed on the screen. (3mks)

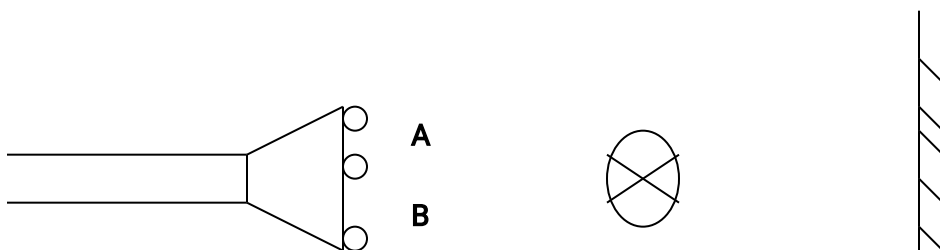

b) In a certain pinhole camera, the screen is 10cm from the pinhole. When the pinhole is placed 6cm away from a tree, a sharp image of a tree 16cm high is formed on the screen. Find the height of the tree. (3mks)

c) Distinguish between Lunar and Solar eclipse by stating the events that lead to the formation of each (4mks)

d) A girl stands 4 m in front of a plane mirror

i. What is the distance between the girl and the mirror (3mks)

ii. Explain how you would use an electroscope to distinguish between a conductor and an insulator (3mks)

15.

a) Fill in the table of charges appropriately (5mks)

Charge on Electroscope	Charge brought near cap	Effects on leaf divergence
+	+	
-	-	
+ or -	Uncharged body	

b) What is the name given to the method of charging an electroscope where it requires an opposite charge to the one of the charging materials? (1mk)

c) Distinguish between a basic physical quantity and a derived physical quantity giving an example of each.

d) State any **two** ways by which frictional force between two surfaces can be reduced. (1mk)

e) Explain why large mercury drops form oval ball on a glass slide (2mks)

f) Explain why a man using a parachute falls through air slowly while a stone falls through air very fast.

(2mks)

ASSIGNMENT 8

1. The diagram below shows a micrometer screw gauge with an error of negative 0.015 cm.

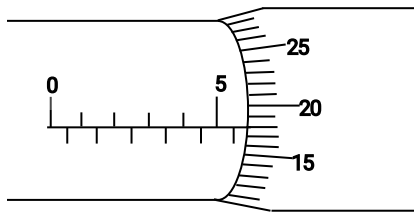

Record the reading shown on the micrometer screw gauge.

(2 marks)

.....
.....

2. Identify the state of equilibrium for each body shown in the figure (a) and (b) below. (2 marks)

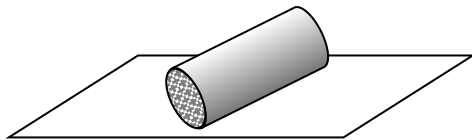

(a)

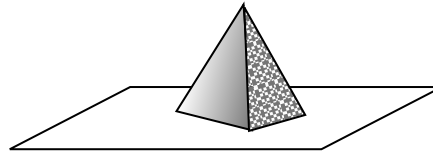

(b)

(a)

(b)

3. You have been given a simple bar magnet. You are also given a string.

(a) How can you easily identify the polarities of the magnet?

(2 marks)

.....
.....
.....

(b) Once you have identified these polarities, you are presented with an unmagnetised piece of iron. You are also given another bar magnet. The poles of this magnet are not identified. How will you identify which of the two new bars is a magnet? (3 marks)

.....
.....
.....

4. A rod placed on a light, frictionless table is acted on by two equal forces that are in opposite directions and are not in equilibrium. State the effects of the forces on the rod. **(2 marks)**

.....
.....

5. (a) Define **moment of a force** and state its **SI** unit. **(2 marks)**

.....
.....

- (b) Explain why it is easier to loosen a tight nut using a spanner with a long handle than one with a short handle. **(1 mark)**

.....
.....

6. One of the extremely light springs shown on the right stretches by 12mm when a mass of 60g exclusively hangs on it. The connecting horizontal bars have a mass of 6g each.

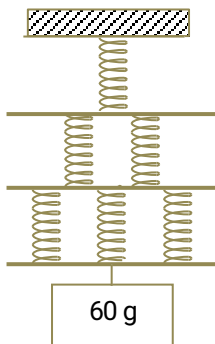

If the mass at the bottom of the arrangement is 60g, calculate the following.

- (a) The extension e_1 of the topmost spring. **(2 marks)**

.....
.....
.....

- (b) The extension e_2 of the next 2 springs. **(2 marks)**

.....

.....
 (c) The total extension e of the spring combination (2 marks)

7. (i) State the principle of moments (1 mark)

(ii) The diagram below shows a uniform metre rule pivoted at its centre and balanced by the forces shown.

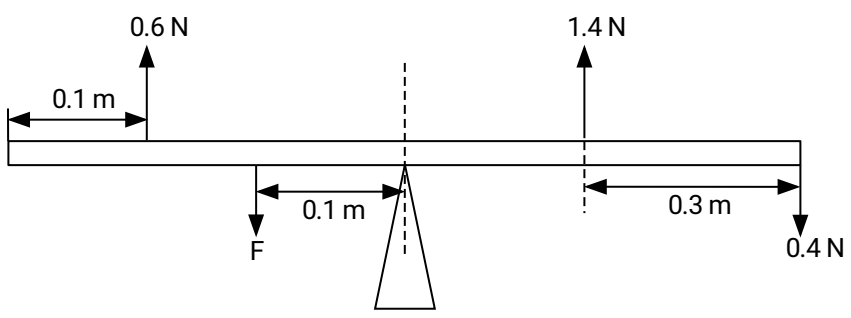

Determine the value of force F . (4 marks)

8. The figure below shows a conductor carrying current through a magnetic field.



Sketch the resultant magnetic field between the poles of the bar-magnet. And the direction at which the conductor moves (3 marks)

9. The diagram below shows two nails suspended in a solenoid. When a direct current is passed through the solenoid, state and explain what is observed. (3 marks)

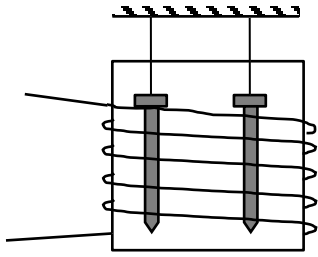

.....

.....

.....

10. A candle is lit and placed on a level bench as shown in figure 4 below.

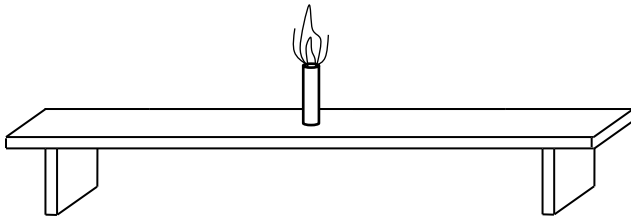

State and explain how the stability of the candle changes as it continues to burn. (2 marks)

.....

.....

11. The narrow beam of light shown below strikes the plane mirror at the angle shown. If the mirror is rotated through an angle of 15° clockwise;

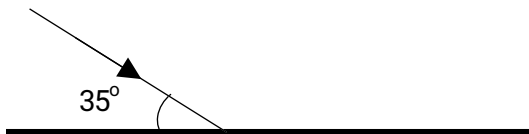

i) By how much does the reflected beam rotate? (1 marks)

.....

.....

ii) Calculate the new angle of reflection.

(2 marks)

.....
.....

12. Two manometers S and T contain liquid Y and water respectively at the same level. They are then connected to a thistle funnel covered with a rubber membrane as shown below.

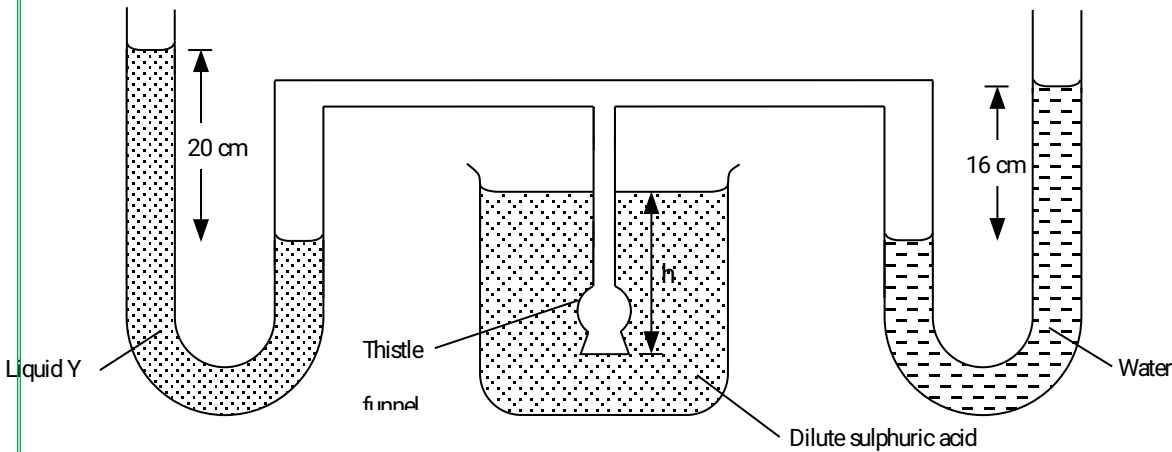

When the thistle funnel is lowered into a beaker containing a dilute Sulphuric acid of density 1250 kgm^{-3} , the heights h_1 and h_2 are 20 cm and 16 cm respectively.

Determine the:

(a) Ratio of density of liquid Y to that of water.

(2 marks)

.....
.....
.....

(b) Depth h of the thistle funnel below the surface of the dilute Sulphuric acid.

(3 marks)

(Take density of water = 1000 kgm^{-3} and $g = 10 \text{ Nkg}^{-1}$)

.....
.....
.....
.....
.....

13. (a) State any **two** uses of a convex mirror.

(2 marks)

.....
.....
.....

(b) A diverging mirror of focal length **18 cm** produces an image on its axis **12 cm** away from the mirror. If the image is **5 cm** high, determine:

(i) The object distance.

(3 marks)

.....
.....
.....
.....

(ii) The height of the object.

(3 marks)

.....
.....
.....
.....

14. State Hooke's law.

(1 mark)

.....
.....

a) One end of a piece of rubber was fixed on a rigid support and the other end pulled with a force of varying magnitude. The graph below shows the relationship between the force (N) and the extension (cm)

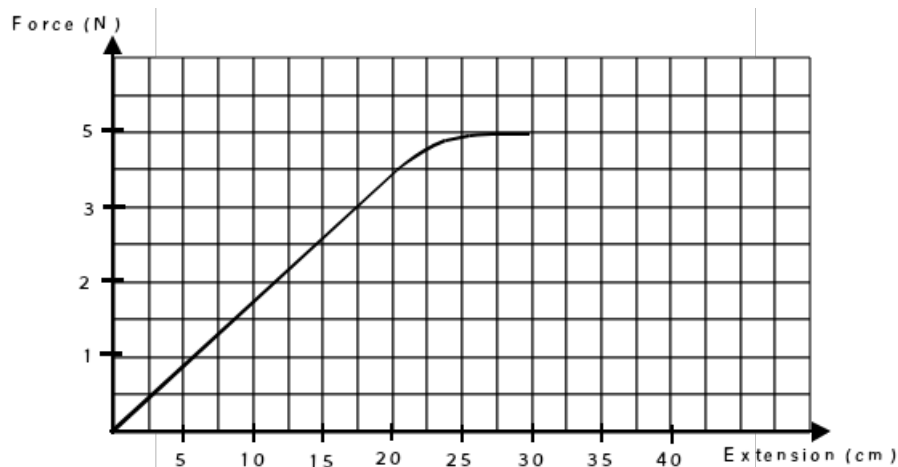

Using the graph, determine

(i) The stretching force at the elastic limit.

(2 marks)

.....
.....

(ii) The constant of elasticity for the rubber.

(2 marks)

.....
.....

(iii) Suppose two identical rubbers were used in series instead of one what would have been.

a. The stretching force at the elastic limit

(1 mark)

.....
.....

b. The elasticity constant for the combined rubbers

(3 marks)

.....
.....

15. The diagram shows a simple voltaic cell and the direction of the current.

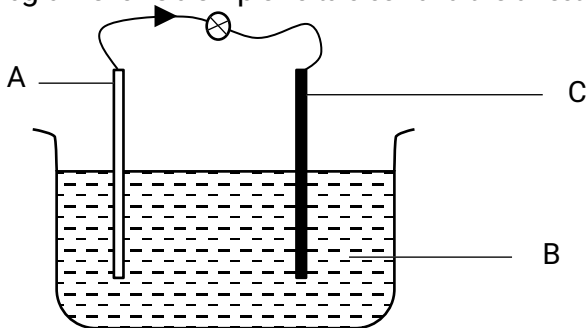

(a) Label the parts marked A, B and C.

(3 marks)

.....
.....
.....

(b) State what happens at

(2 marks)

(i) A

.....
.....

(ii) C

.....

.....

(c) Name the effect that occurs at (i) and at (ii)

(2 marks)

.....
.....

(d) It is observed that bulb glows and goes off immediately. How can it be made to light again for a short while.

(1 mark)

.....
.....

(e) What two modification can be done on this cell so as to make it produce larger current and for long time.

(2 marks)

.....
.....

16. A sharp needle is placed on top of an uncharged electroscope.

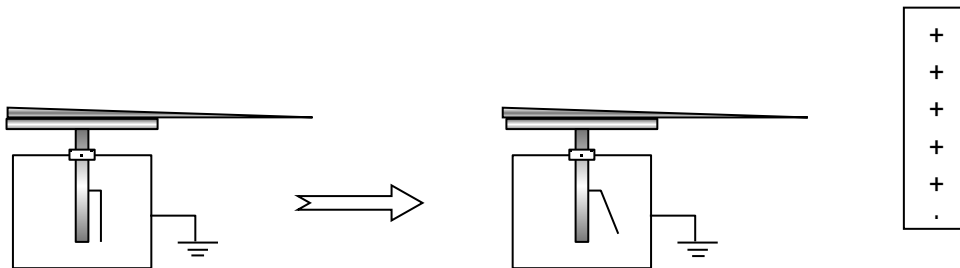

(a) When a positively charged rod is held close to but not touching the needle, a deflection is seen. Explain how the deflection arises.

(2 marks)

.....
.....
.....

(b) When the positively charged rod is now removed, the deflection reduces slightly. Explain why this new deflection remains.

(2 marks)

.....

ASSIGNMENT 9

1. Distinguish between mass and weight of a body stating the S.I units for each. (2mks)

.....

2. The figure below shows part of scale of vernier calipers.

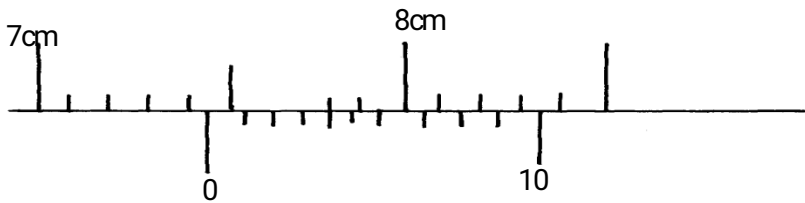

What is the reading indicated on the scale (1mk)

4. Explain why fish can survive under water when the surface is already frozen (2mks)

.....

6. State **one** advantage of an alkaline battery over a lead acid battery. (1mk)

.....

7. The diagram below shows a permanent magnet suspended by a spring. State with reason the behaviour of the magnet when the switch is closed. (2mks)

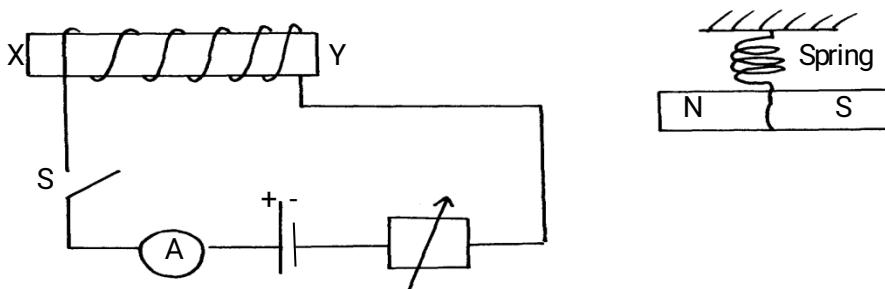

8. Define the following terms as used in curved mirrors

(a) Principal focus (1 mk)

(b) Centre of curvature (1 mk)

(c) Focal plane (1 mk)

9. State three applications of curved mirrors (3 mks)

9. A concave mirror of focal length 10cm forms a virtual image 5cm high and 30cm from the mirror. By an accurate scale drawing determine;

(a) The position of the object (3 mks)

(b) The height of the object

(3 mks)

(c) Magnification of the image

(3 mks)

.....
.....

8. Convection and diffusion both involve motion of fluids. Distinguish between the two. (2mks)

.....
.....
.....
.....

9. A negatively, charged rod is brought close to (but not touching) an uncharged sphere. If the sphere is momentarily earthed and then the rod is removed, briefly explain what happens. (2mks)

.....
.....

14. (a) State **Hooke's law** . (1mk)

.....
.....

(b) The following readings were obtained when a spring was loaded gradually;

Load (N)	0	10	20	30	40	50	60	70	80
Extension(cm)	0	12	25	37	48	60	70	78	85

(i) Plot a graph of load (N) against extension(cm) (5mks)

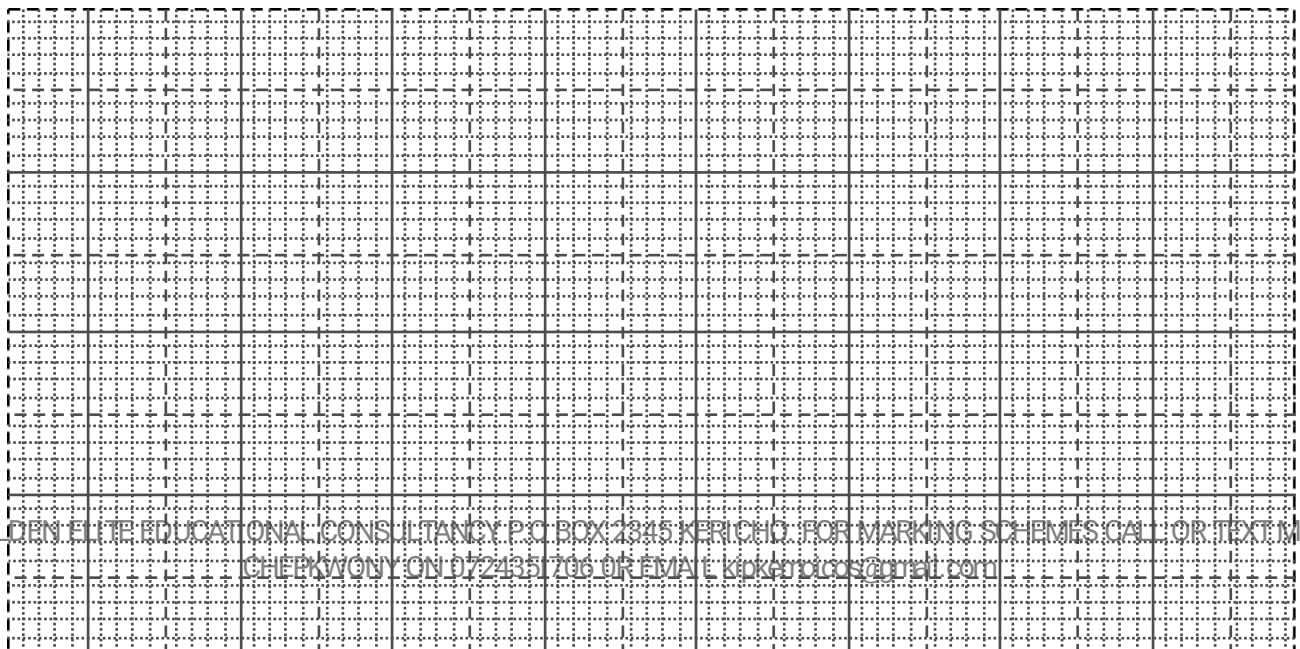

(ii) Mark on your graph the elastic limit **P**.

(1mk)

.....
.....
.....

(iii) Determine from the graph the elasticity constant of the material of the wire.

(3mks)

.....
.....
.....
.....

.....
.....
.....

16. (a) Define **pressure** and give its S.I nits.

(2mks)

.....
.....

(b) The diagram below represents a motor car hydraulic braking system;

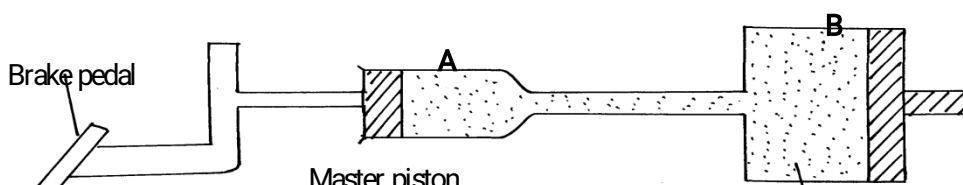

(i) State **two** properties of the liquid used as a brake fluid (2mks)
.....
.....

(ii) Given that in the diagram (b) above the master piston has an area of 15cm^2 and the slave piston has an area of 50cm^2 a force of 100N is applied on the master piston. Find the force used to stop the car. (3mks)
.....
.....
.....
.....

(c) Compare the values of pressure in the two pistons above and give a reason for your answer. (2mks)
.....
.....

(d) Give a reason why gas is not suitable for use in place of the brake fluid. (1mk)
.....

17. (a) Define **centre of gravity**. (1mk)
.....
.....

(b) State **two** factors affecting stability of a book. (2mks)
.....
.....

(c) Use simple sketches to show the three states of equilibrium. Name the states. (3mks)

18. (a) Distinguish between a **longitudinal wave** and a **transverse wave**. (1mk)
.....
.....

(b) The figure below shows a displacement time graph of a wave. The velocity of the wave is 0.4m/s

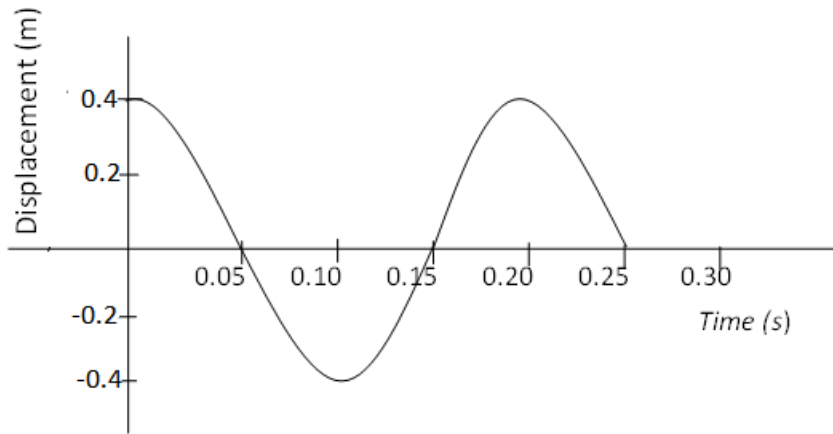

Determine;

(i) The amplitude (1mk)

.....

(ii) The period (1mk)

.....

(iii) The wavelength (2mks)

.....

(c) State **one** disadvantage of a convex mirror when used as a car driving mirror (1mk)

.....

(d) What property of light is suggested by the formation of shadows? (1mk)

.....

**FOR MARKING SCHEMES CALL OR TEXT MR
 CHEPKWONY ON 0724351706**

Also available are the following assignments for all

classes (F1-4)

- 1) **Kiswahili**
- 2) **Maths**
- 3) **English**
- 4) **Chemistry**
- 5) **Biology**
- 6) **History**
- 7) **CRE**
- 8) **Business**
- 9) **Agriculture**
- 10) **Home science**
- 11) **Physics**
- 12) **geography**