

MATHEMATICS PAPER 2 KCSE PAST PAPERS(1995-2016)

For marking schemes,call/Whatsapp-0746711892



'an investment of knowledge pays'

For marking schemes,prefer calling Mdm Mariam:0746711892

Other available resources are;

📌 well summarised primary and secondary
notes

📌 FI-F4 termly exams

📌 primary exams

📌 KCSE past papers

📌 KCPE past papers

📌 Mocks

📌 lesson plans

📌 schemes of work

Note:Exam questions are always free of charge

Marking scheme are not free

MATHEMATICS
K.C.S.E PAPER 121/ 2 1995
QUESTIONS

QUESTIONS SECTION 1 (52 MKS)

1. Use logarithms to evaluate $\frac{(0.07284)^2}{3\sqrt{0.06195}}$ (4 mks)

2. Solve the simultaneous equations (4 mks)

$$\begin{aligned} 2x - y &= 3 \\ x^2 - xy &= -4 \end{aligned}$$

3. The tables shows the yearly percentage taxations rates.

Year	1987	1988	1989	1990	1991	1992	1993	1994
Percentage taxatio	65	50	50	45	45	45	40	40

- Calculate three- yearly moving averages for the data giving answers to s.f (3 mks)

4. Calculate volume of a prism whose length is 25cm and whose cross- section is an equilateral triangles of 3 cm

5. Find the value of x in the following equations:
 $49^{x+1} + 7^{2x} = 350$ (4 mks)

6. A translation maps a point (1,2) onto (-2, 2). What would be the coordinates of the object whose image is (-3, -) under the same translation?

7. The ratio of the lengths of the corresponding sides of two similar rectangular water tanks is 3:5. The volume of the smaller tank is 8.1 m^3 . Calculate the volume of the larger tank. (3 mks)

8. Simplify completely

2

$$\frac{3x^2 - 1}{x^2 - 1} - \frac{2x + 1}{x + 1}$$

9. A boat moves 27 km/h in still water. It is to move from point A to a point B which is directly east of A. If the river flows from south to North at 9 km/h, calculate the track of the boat.
10. The second and fifth terms of a geometric progression are 16 and 2 respectively. Determine the common ratio and the first term
11. In the figure below $CP = CQ$ and $\angle CQP = 160^\circ$. If ABCD is a cyclic quadrilateral, find $\angle BAD$.
12. In the figure below, $OA = 3i + 3j$, $OB = 8i - j$, C is a point on AB such that $AC:CB = 3:2$, and D is a point such that $OB \parallel CD$ and $2OB = CD$.

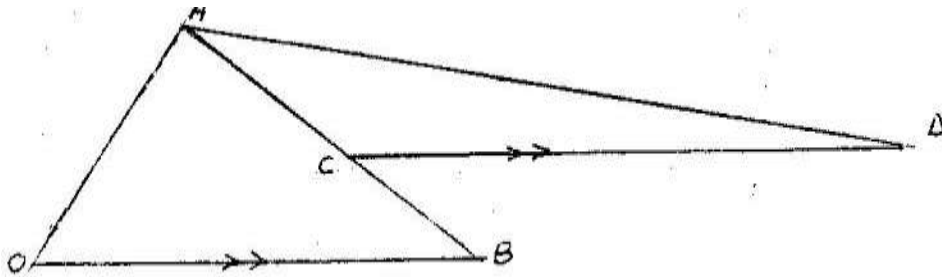

Determine the vector DA in terms of i and j . (4 mks)

13. Without using logarithm tables, find the value of x in the equation

$$\log x^3 + \log 5x = 5 \log 2 - \log 2 \quad (3 \text{ mks})$$

5

14. Two containers, one cylindrical and one spherical, have the same volume. The height of the cylindrical container is 50 cm and its radius is 11 cm. Find the radius of the spherical container. (2 mks)
15. Two variables P and L are such that P varies partly as L and partly as the square root of L . Determine the relationship between P and L when $L = 16$, $P = 500$ and when $L = 25$, $P = 800$. (5 mks)
16. The shaded region below represents a forest. The region has been drawn to scale where 1 cm represents 5 km. Use the mid-ordinate rule with six strips to estimate the area of forest in hectares. (4 mks)

SECTION II (48 Marks)

Answer any six questions from this section

17. A circular path of width 14 metres surrounds a field of diameter 70 metres. The path is to be carpeted and the field is to have a concrete slab with an exception of four rectangular holes each measuring 4 metres by 3 metres.

A contractor estimated the cost of carpeting the path at Kshs. 300 per square metre and the cost of putting the concrete slab at Kshs 400 per square metre. He then made a quotation which was 15% more than the total estimate. After completing the job, he realized that 20% of the quotation was not spent.

- (a) How much money was not spent?
(b) What was the actual cost of the contract?

18. The table below shows high altitude wind speeds recorded at a weather station in a period of 100 days.

Wind speed (knots)	0 - 19	20 - 39	40 - 59	60-79	80- 99	100- 119	120-139	140-159	160-179
Frequency (days)	9	19	22	18	13	11	5	2	1

- (a) On the grid provided draw a cumulative frequency graph for the data (4 mks)

- (b) Use the graph to estimate
(i) The interquartile range (3 mks)

- (ii) The number of days when the wind speed exceeded 125 knots (1 mk)

19. The probabilities that a husband and wife will be alive 25 years from now are 0.7 and 0.9 respectively.
Find the probability that in 25 years time,

- (a) Both will be alive
(b) Neither will be alive
(c) One will be alive
(d) At least one will be alive

20. A hillside is in the form of a plane inclined at an angle of 30° to the horizontal. A straight section of road 800 metres long lies along the line of greatest slope from a point A to a point B further up the hillside.

- (a) If a vehicle moves from A and B, what vertical height does it rise?
 (b) D is another point on the hillside and is on the same height as B. Another height straight road joins and D and makes an angle of 60° with AB. C is a point on AD such that $AC = \frac{3}{4} AD$.

Calculate

- (i) The length of the road from A to C
 (ii) The distance of CB
 (iii) The angle elevation of B and C

21. A part B is on a bearing of 080° from a port A and at a distance of 95 km. A submarine is stationed at a port D, which is on a bearing of 200° from AM and a distance of 124 km from B.
 A ship leaves B and moves directly southwards to an island P, which is on a bearing of 140° from A. The submarine at D on realizing that the ship was heading for the island P, decides to head straight for the island to intercept the ship

Using a scale of 1 cm to represent 10 km, make a scale drawing showing the relative positions of A, B, D, P. (2 mks)

Hence find

- (i) The distance from A to D (2 mks)
 (ii) The bearing of the submarine from the ship was setting off from B (1mk)
 (iii) The bearing of the island P from D (1 mk)
 (iv) The distance the submarine had to cover to reach the island P (2 mks)

22. Using ruler and compasses only, construct a parallelogram ABCD such that $AB = 10\text{cm}$, $BC = 7\text{cm}$ and $\angle ABC = 105^\circ$. Also construct the loci of P and Q within the parallel such that $AP \leq 4\text{ cm}$, and $BC \leq 6\text{ cm}$. Calculate the area within the parallelogram and outside the regions bounded by the loci.

23. (a) Complete the table for the function $y = 2 \sin x$ (2 mks)

x	0°	10°	20°	30°	40°	50°	60°	70°	80°	90°	100°	110°	120°
Sin 3x	0	0.5000											
y	0	1.00											

(b) (i) Using the values in the completed table, draw the graph of $y = 2 \sin 3x$ for $0^\circ \leq x \leq 120^\circ$ on the grid provided

(ii) Hence solve the equation $2 \sin 3x = -1.5$ (3 mks)

24. A manufacture of jam has 720 kg of strawberry syrup and 800 kg of mango syrup for making two types of jam, grade A and B. Each types is made by mixing strawberry and mango syrups as follows:

Grade A: 60% strawberry and 40% mango

Grade B: 30% strawberry and 70% mango

The jam is sold in 400 gram jars. The selling prices are as follows: Grade A: Kshs. 48 per jar
Grade B: Kshs 30 per jar.

(a) Form inequalities to represent the given information (3 mks)

(b) (i) On the grid provided draw the inequalities (3 mks)

(ii) From your, graph, determine the number of jars of each grade the manufacturer should produce to maximize his profit (1 mk)

(iii) Calculate the total amount of money realized if all the jars are sold (1 mk)

MATHEMATICS
K.C.S.E PAPER 121/ 2 1996
QUESTIONS

QUESTIONS SECTION 1 (52 Marks)
Answer all questions in this section

1. Evaluate without using mathematical tables

$$\frac{1.9 \times 0.032}{20 \times 0.0038}$$

2. Mary has 21 coins whose total value is Kshs 72. There are twice as many five shillings coins as there are ten shillings coins. The rest are one shillings coin. Find the number of ten shillings coins that Mary has.
3. A commercial bank buys and sells Japanese yen in Kenya shillings at the rates shown below.

Buying	Selling
Kshs 0.5024	Kshs. 0.5446

A Japanese tourist at the end of his tour of Kenya was left with Kshs 30,000 which he converted to Japanese yen through the commercial bank. How many Japanese yen did he get?

4. On the figure below construct

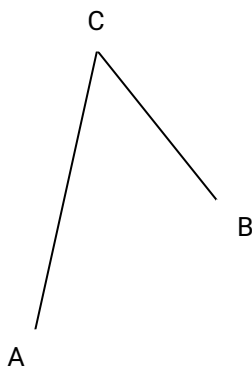

- (i) the perpendicular bisector of BC
- (ii) The locus of a point P which moves such a way that $\angle APB = \angle AVB$ and P is on the same side of AB on the same side of AB as C

5. The figure below represents a circle a diameter 28 cm with a sector subtending an angle of 75° at the centre.

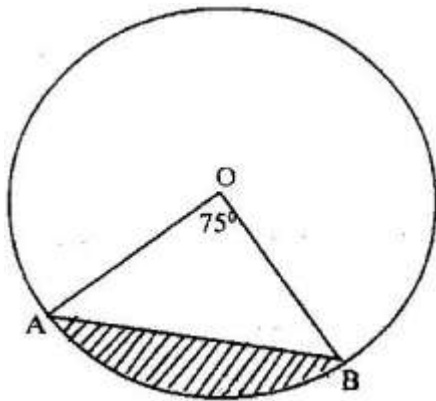

Find the area of the shaded segment to 4 significant figures

7. Use the trapezoidal rule with intervals of 1 cm to estimate the area of the shaded region below

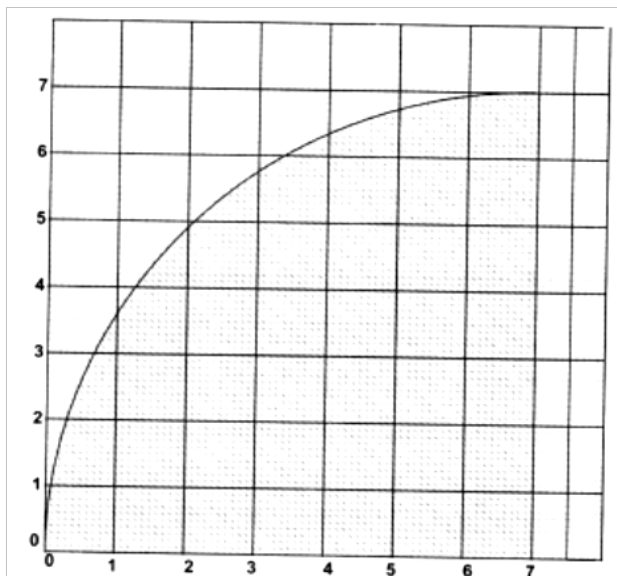

8. Expand and simplify $(1 - 3x)^5$, up to the term in x^3

Hence use your expansion to estimate $(0.97)^5$ correct to 4 decimal places

9. On the surface of a cuboid ABCDEFGH a continuous path BFDHB is drawn as shown by the arrows below.

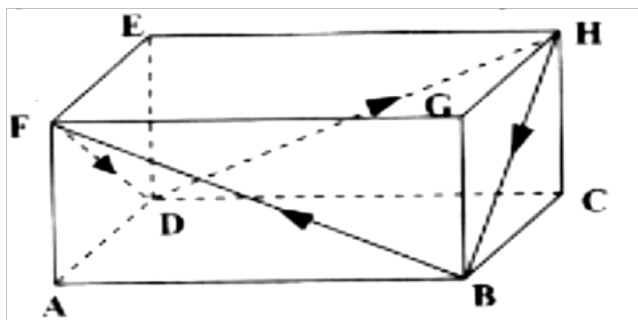

- (a) Draw and label a net of cuboid
 (b) On the net show the path
10. ABC is a triangle and P is on AB such that P divides AB internally in the ratio 4:3.
 Q is a point on AC such that PQ is parallel to BC. If AC = 14 cm
 (i) State the ratio AQ:QC

11. Find the values of a and b where b are rational numbers

12. The table below represents the mean scores in six consecutive assessment tests given a form four class

Tests	T ₁	T ₂	T ₃	T ₄	T ₅	T ₆
Mean scores in percentage	48.40	56.25	50.30	49.00	45.60	57.65

Calculate the three moving averages of order 4

13. Mogaka and Onduso working together can do a piece of work in 6 days, Mogaka, working alone takes 5 days longer than Onduso. How many days does it take Onduso to do the work alone?
14. The athletes in an 800 metres race take 104 seconds and 108 seconds respectively to complete the race. Assuming each athlete is running at a constant speed. Calculate the distance between them when the faster athlete is at the finishing line.
15. A metal bar is a hexagonal prism whose length is 30 cm. The cross – section is a regular hexagon with each side of the length 6 cm.
 Find
 (i) the area of the hexagonal face
 (ii) the volume of the metal bar

SECTION II (48 MKS)
Answer any six questions from this section

17. A company is to construct a parking bay whose area is 135m^2 . It is to be covered with concrete slab of uniform thickness of 0.15. To make the slab cement, Ballast and sand are to be mixed so that their masses are in the ratio 1: 4: 4. The mass of m^3 of dry slab is 2, 500kg.

Calculate

(a) (i) The volume of the slab

(ii) The mass of the dry slab

(iii) The mass of cement to be used

(b) If one bag of the cement is 50 kg, find the number of bags to be purchased

(c) If a lorry carries 7 tonnes of sand, calculate the number of lorries of sand to be purchased

18. Complete the table below by filling in the blank spaces

x^0	0^0	30^0	60^0	90^0	120^0	150^0	180^0	210^0	240^0	270^0	300^0	330^0	360^0
$\text{Cos } x^0$	1.00	0.87	0.50	0	-0.5	-0.87	-1.0	-0.87	-0.5	0	0.5	0.87	1.0
$2 \cos \frac{1}{2} x^0$	2.00	1.93	1.73	1.41	1.0	0.52	0	0.52	-1.00	1.47	1.73	1.93	-2.00

Using the scale 1 cm to represent 30^0 on the horizontal axis and 4 cm to represent 1 unit on the vertical axis draw, on the grid provided, the graphs of $y = \cos x^0$ and $y = 2 \cos \frac{1}{2} x^0$ on the same axis.

(a) Find the period and the amplitude of $y = 2 \cos \frac{1}{2} x^0$

(b) Describe the transformation that maps the graph of $y = \cos x^0$ on the graph of $y = 2 \cos \frac{1}{2} x^0$

19. An institute offers two types of courses technical and business courses. The institute

has a capacity of 500 students. There must be more business students than technical

students but at least 200 students must take technical courses. Let x represent the

number of technical students and y the number of business students.

- (a) Write down three inequalities that describe the given conditions
- (b) On the grid provided, draw the three inequalities
- (c) If the institute makes a profit of Kshs 2,500 to train one technical student and Kshs 1,000 to train one business student, determine
- the number of students that must be enrolled in each course to maximize the profit
 - The maximum profit.

20. In the figure below PQR is the tangent to circle at Q. TS is a diameter and TSR and QUV are straight lines. QS is parallel to TV. Angles $\angle SQR = 40^\circ$ and $\angle TQV = 55^\circ$

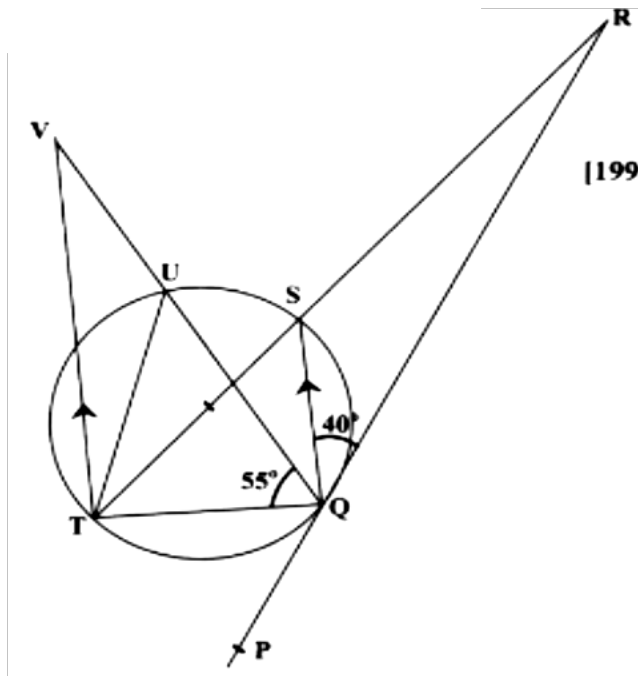

Find the following angles, giving reasons for each answer

- QST
- QRS
- QVT
- UTV

21. The volume $v\text{cm}^3$ of a solid depends partly on r^2 and partly on r^3 where $r\text{ cm}$ is one of the dimensions of the solid

When $r = 1$, the volume is 54.6 cm^3 and

When $r = 2$, the volume is 226.8 cm^3

- (a) Find the expression for v in terms of r
- (b) Calculate the volume of the solid when $r = 4$
- (c) Find the value of r for which the two parts of the volume are equal

MATHEMATICS

K.C.S.E PAPER 121/ 2 1998

QUESTIONS

SECTION 1 (52 MKS)

Answer the entire question in this section

1. Use logarithms to evaluate

$$55.9 \div (0.2621 \times 0.01177)^{\frac{1}{5}}$$

2. Simplify the expression $\frac{x-1}{x} - \frac{2x-1}{3x}$

Hence solve the equation

$$\frac{x-1}{x} - \frac{2x+1}{3x} = 2$$

3. Simplify as far as possible, leaving your answer in the form of surd

$$\frac{1}{\sqrt{4-2\sqrt{3}}} - \frac{1}{\sqrt{14+2\sqrt{3}}}$$

4. In the figure below $\angle ABC = 30^\circ$, $\angle ACB = 90^\circ$, $AD = 4\sqrt{3}$ and $DC = 4\text{cm}$

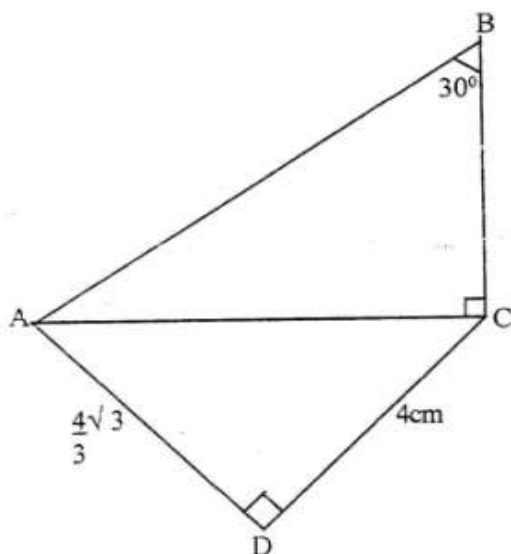

$$\frac{8}{\sqrt{3}} + \frac{1}{\sqrt{3}} \text{ if A is lost}$$

Calculate the length of

(a) AC

(b) BC

5. A plot of land was valued at Kshs 50,000 at the start of 1994. It appreciated by 20% during 1994. Thereafter, every year, it appreciated by 10% of its previous years value.
- The value of the land at the start of 1995
 - The value of the land at the end of 1997

6. During a certain period, the exchange rate were follows
- 1 sterling pound = Kshs. 102.0
 - 1 sterling pound = Kshs. U.S dollar
 - 1 U.S dollar = Kshs. 60.6

A school management intended to import textbooks worth Kshs 500,00 from U.K. It changed the money to sterling pounds. Later the management found out that books were cheaper in U.S.A. Hence it changed the sterling pounds to dollars. Unfortunately, a financial crisis arose and the money had to be reconverted to Kenya shillings.

Calculate the total amount of money the management ended up with

7. A manufacturer sells bottle of fruit juice to a trader at a profit of 40%. The trader sells it for Kshs 84 at a profit of 20%. Find
- The trader's buying price
 - The cost of manufacture of one bottle

8. In the figure below a line XY and three points. A,B and C are given. On the figure construct

(a) The perpendicular bisector of AB

(b) A point P on line xy such that $\angle APB = \angle ACB$

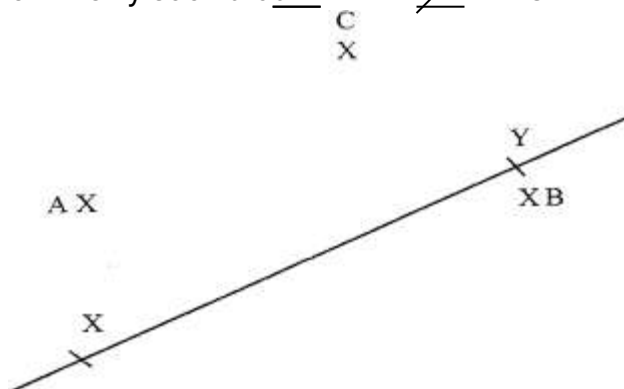

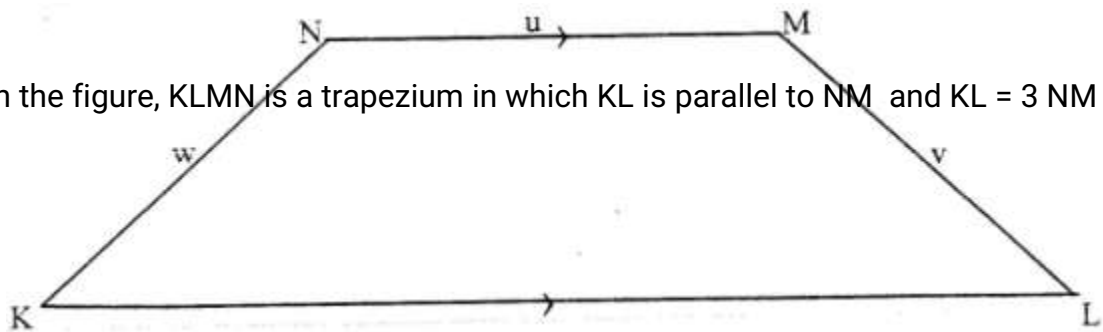

9. In the figure, KLMN is a trapezium in which KL is parallel to NM and $KL = 3 NM$

Given that $KN = w$, $NM = u$ and $ML = v$
 Show that $2u = v = w$

10. Given that $P = 3y$ express the equation $3^{2y-1} + 2 \times 3^{y-1} = 1$ terms of AP Hence or otherwise find the value of y in the equation $3^{2y-1} + 2 \times 3^{y-1} = 1$

11. A balloon, in the form of a sphere of radius 2 cm, is blown up so that the volume increase by 237.5%. Determine the new volume of balloon in terms of π

12. Find x if

$$3 \log 5 + \log x^2 = \log \frac{1}{125}$$

13. (a) Write down the simplest expansion $(1 + x)^6$
 (b) Use the expansion up to the fourth term to find the value of $(1.03)^6$ to the nearest one thousandth.

14. A science club is made up of boys and girls. The club has 3 officials. Using a tree diagram or otherwise find the probability that:

- (a) The club official are all boys
 (b) Two of the officials are girls

15. A river is flowing at uniform speed of 6km/ h. A canoeist who can paddle at 10 km/h through still water wishes to go straight across the river. Find the direction, relative to the bank in which he should steer.

16. The triangular prism shown below has sides $AB = DC = EF = 12$ cm. The ends are equilateral triangle of sides 10 cm. The point N is the midpoint FC.

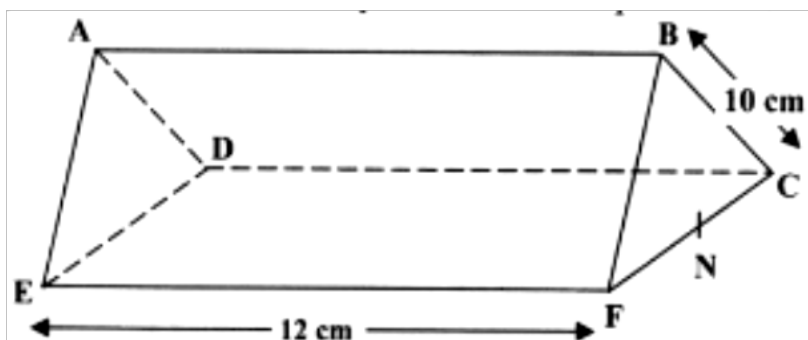

- (a) Find the length of
 (i) BN
 (ii) EN
- (b) Find the angle between the line EB and the plane CDEF

SECTION II (48 mks)

Answer any six questions from this section

17. A cylindrical water tank is a diameter 7 meters and height 2.8 metre

- (a) Find the capacity of the water tank in litres
- (b) Six members of a family use 15 litres per day. Each day 80 litres are used for cooking and washing and a further 60 litres are wasted.
 Find the number of complete days a full tank of water would last the family.

18. (a) Complete the table below for the value of $y = 2 \sin x + \cos x$.

x	0°	30°	45°	60°	90°	120°	135°	150°	180°	225°	270°	315°	360°
$2 \sin x$	0		1.4	1.7	2	1.7	1.4	1	0		-2	-1.4	0
$\cos x$	1		0.7	0.5	0	-0.5	-0.7	-0.9	-1		0	0.7	1
y	1		2.1	2.2	2	1.2	0.7	0.1	-1		-2	-0.7	1

(b) Using the grid provided draw the graph of $y = 2 \sin x + \cos x$ for 0° .
Take 1 cm represent 30° on the x-axis and 2 cm to represent 1 unit on the axis.

(c) Use the graph to find the range of x that satisfy the inequalities $2 \sin x \cos x > 0.5$

19. In the figure below, QOT is a diameter. $\angle QTR = 48^\circ$, $\angle TQR = 76^\circ$ and $\angle SRT = 37^\circ$

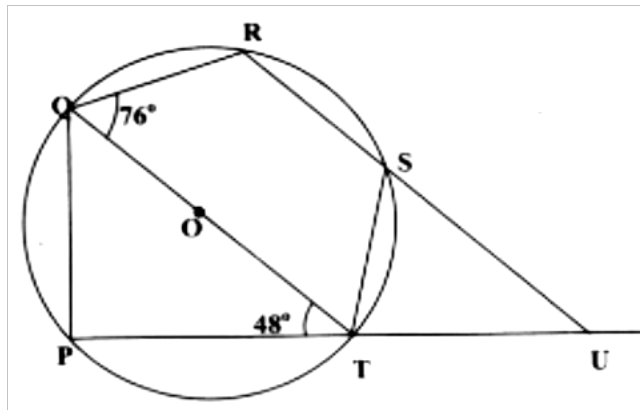

Calculate

- (a) $\angle RST$
 (b) $\angle SUT$
 (c) Obtuse $\angle RUT$
 (d) $\angle PST$

20. (a) Find the value of x at which the curve $y = x - 2x^2 - 3$ crosses the x-axis

(b) $\int (x^2 - 2x - 3) dx$

(c) Find the area bounded by the curve $y = x^2 - 2x - 3$, the axis and the lines $x = 2$ and $x = 4$

21. Two variables R and V are known to satisfy a relation $R = kV^n$, where k and n are constants. The table below shows data collected from an experiment involving the two variables R and

V	3	4	5	6	7	8
R	27	48	75	108	147	192

(a) Complete the table of $\log V$ and R given below, by giving the value to 2

decimal places.

Log V	0.48	0.60	0.70	0.78	0.85	0.90
Log R	1.43	1.88	2.03	1.80	2.28	

(b) On the grid provided draw a suitable straight line graph to represent the relation $R = kV^n$

- (c) (i) the gradient of the line
(ii) a relationship connecting R and V.

22. Two aeroplane P and Q leaves an airport at the same time. P lies on a bearing of 240° at 900 km/ h while Q flies due east at 750 km/ h.

(a) Using a scale of 1 cm to represents 100km, make a scale drawing to show the position of the aeroplane after 40 minutes.

(b) Use the scale drawing to find the distance between the two aeroplane after 40 minutes. (c) Determine the bearing

- (i) P from Q
(ii) Q from P

23. The figure below represents a rectangle PQRS inscribed in a circle centre O and radius 17cm .PQ = 16cm.

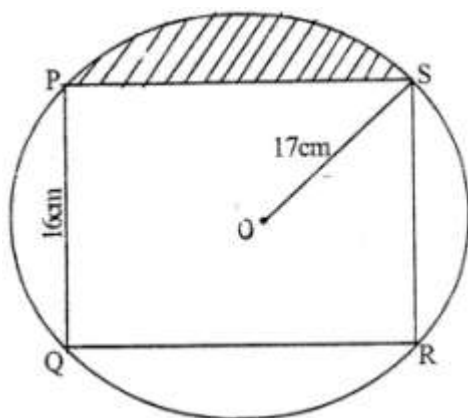

Calculate

(d) The length PS of the rectangle

(e) The angle POS

(f) The area of the shaded region

24. A draper is required to supply two types of shirts A and type B.

The total number of shirts must not be more than 400. He has to supply more type A than of type B however the number of types A shirts must be more than 300 and the number of type B shirts not be less than 80.

Let x be the number of type A shirts and y be the number of types B shirts.

(a) Write down in terms of x and y all the linear inequalities representing the information above.

(b) On the grid provided, draw the inequalities and shade the unwanted regions

Type A: Kshs 600 per shirt

Type B: Kshs 400 per shirt

(i) Use the graph to determine the number of shirts of each type that should be made to maximize the profit.

(ii) Calculate the maximum possible profit.

MATHEMATICS
K.C.S.E PAPER 121/ 2 1995
QUESTIONS

SECTION 1 (52 Marks)

Answer all the questions in this section

1. Use logarithms to evaluate $\frac{6.79 \times 0.3911^{3/4}}{\text{Log } 5}$
2. Find the range of x if $2 \leq 3 - x < 5$
3. The mass of a mixture A of beans and maize is 72kg. The ratio of beans to maize is 3:5 respectively
 - (a) Find the mass of maize in the mixture
 - (b) A second mixture of B of beans and maize of mass 98 kg is mixed with A. The final ratio of beans to maize is 8:9 respectively. Find the ratio of beans to maize in B
4. Simplify $\sqrt{2^x \times 5^{2x} + 2^{-x}}$
5. In the month of January, an insurance salesman earned Kshs 6750 which was a commission of 4.5% of the premium paid to the company.
6. Solve for x $(\log_3 x)^2 - \frac{1}{2} \log_3 \frac{3}{2}$
7. The equation of a line is $-\frac{3}{5}x + 3y = 6$

Find the:

- (a) Gradient of the line
- (b) Equation of a line passing through point (1,2) and perpendicular to the given line.

8. The figure below shows a solid made by passing two equal regular tetrahedra.

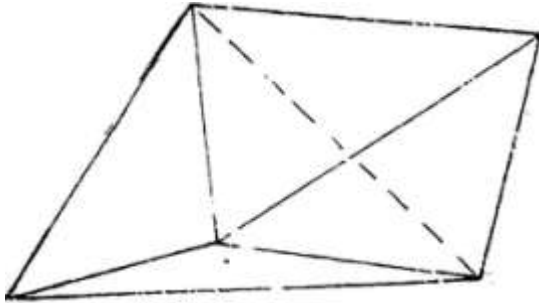

- (a) Draw a net solid
- (b) If each face is an equilateral triangle of side 5cm find the surface area of the solid
9. Two towns A and B are 220km apart. A bus left town A at 11. 00am and traveled towards B at 60 km/h. At the same time, a matatu left town B for town A and traveled at 80 km/h. The matatu stopped for a total of 45 minutes on the way before meeting the bus. Calculate the distance covered by the bus before meeting the matatu.
10. Use binomial expression to evaluate $(0.96)^5$ correct to 4 significant figures
11. In the figure below triangle ABO represents a part of a school badge. The badge has as symmetry of order 4 about O. Complete the figures to show the badge.

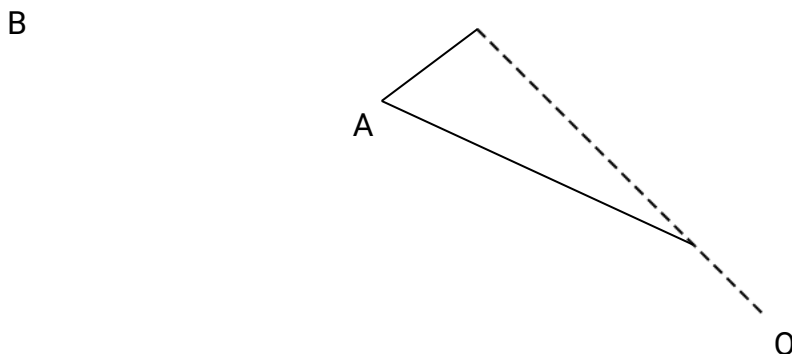

12. Solve the equation
 $8s^2 + 2s - 3 = 0$

Hence solve the equation

$$8 \sin^2\theta + 2\sin\theta - 3 = 0 \text{ for } 0^\circ \leq \theta \leq 180^\circ$$

13. The number of people who attended an agricultural show in one day was 510 men, 1080 women and some children. When the information was represented on a pie chart, the combined angle for the men and children was 216° . Find the angle representing the children.
14. The points P, Q and R lie on a straight line. The position vectors of P and R are $2\mathbf{i} + 2\mathbf{j} + 13\mathbf{k}$ and $5\mathbf{i} - 3\mathbf{j} + 4\mathbf{k}$ respectively. Q divides PR internally in the ratio 2:1

Find the

(a) Position vector of Q.

15. A construction firm has tractors T_1 and T_2 . Both tractors working together can complete a piece of work in 6 days while T_1 alone can complete the work in 15 days. After two tractors had worked together for four days, tractor T_1 broke down.

Find the time it takes tractor T_2 to complete the remaining work

16. Find the equation of the tangent to the curve

$$y = (x^2 + 1)(x - 2) \text{ when } x = 2$$

SECTION II (48 Marks)

Answer any six questions from this section

17. A retailer bought 49kg of grade 1 rice at Kshs. 65 per kilogram and 60 kg of grade II rice at Kshs 27.50 per kilogram. He mixed the two types of rice.

(a) Find the buying price of one kilogram of the mixture

(b) He packed the mixture into 2 kg packets

(i) If he intends to make a 20% profit find the selling price per packet

(ii) He sold 8 packets and then reduced the price by 10% in order to attract customers.

Find the new selling price per packet.

- (iii) After selling of the remainder at reduced price, he raised the price so as to realize the original goal of 20% profit overall. Find the selling price per packet of the remaining rice.

18. A tower is on a bearing of 030° from a point P and a distance of elevation of the top is 15° and the angle of depression of the foot of the tower is 1° .

a) Find the height of the tower

b) A point Q is on the same horizon plane as point P. The tower is on a bearing 330° from Q and at a distance of 70 m

19. Patients who attend a clinic in one week were grouped by age as shown in the table below:

Age x years	$0 \leq x < 5$	$5 \leq x < 15$	$15 \leq x < 25$	$25 \leq x < 45$	$45 \leq x < 75$
No. of patients	14	41	59	70	15

i. Estimate the mean age

ii. On the grid provided draw a histogram to represent the distribution

1 cm to represent 5 unit on the horizon axis

2 cm to represent 5 units on the vertical axis

20. The first term of an arithmetic progression is 4 and the last term is 20. The sum of the term is 252.

(a) Calculate the number of terms and the common differences of the arithmetic progression

(b) An Experimental culture has an initial population of 50 bacteria. The population increased by 80% every 20 minutes. Determine the time it will take to have a population of 1.2 million bacteria.

21. The diagram below shows a garden drawn to scale of 1: 400. In the garden there are already two trees marked A and B. The gardener wishes to plant more trees. There are a number of rules he wishes to apply.

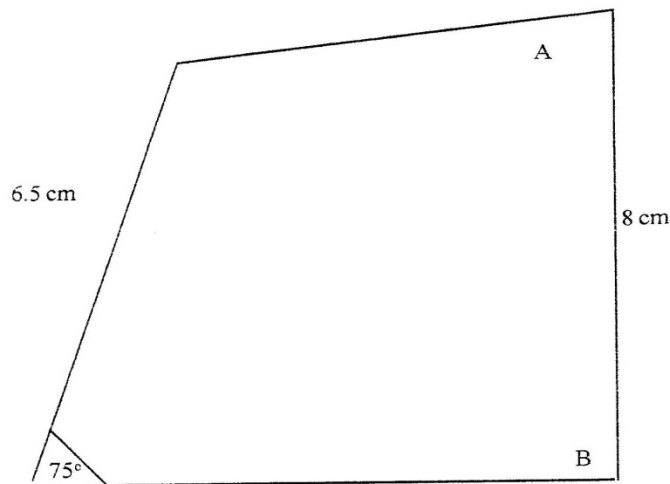

Rule 1: Each new tree must be an equal distance from both trees A and B. Rule 2: Each new tree must be at least 4 m from the edges of the garden. Rule 3: each new tree is at least 14 m from tree B.

- (a) draw the locus given by each of these rules on the diagram
- (b) If the new trees are to be planted 4m apart, show on your diagram the possible planting points for the new trees.

22. (a) complete the table below, giving your values correct to 2 decimal places.

x	0	10	20	30	40	50	60	70
Tan x	0							
$2x + 30^\circ$	30	50	70	90	110	130	150	170
$\sin(2x + 30^\circ)$	0.50			1				

- b) On the grid provided, draw the graphs of $y = \tan x$ and $y = \sin(2x + 30^\circ)$ for $0^\circ \leq x < 70^\circ$

Take scale: 2 cm for 100 on the x- axis
4 cm for unit on the y- axis

Use your graph to solve the equation $\tan x - \sin (2x + 30^\circ) = 0$

23. The transformation R given by the matrix

$$A = \begin{pmatrix} a & b \\ c & d \end{pmatrix} \text{ maps } \begin{pmatrix} 17 \\ 0 \end{pmatrix} \text{ to } \begin{pmatrix} 15 \\ 8 \end{pmatrix} \begin{pmatrix} 0 \\ 17 \end{pmatrix} \text{ to } \begin{pmatrix} -8 \\ 15 \end{pmatrix}$$

(a) Determine the matrix A giving a,b,c and d as fractions

(b) Given that A represents a rotation through the origin determine the angle of rotation

(c) S is a rotation through 180° about the point (2, 3). Determine the image of (1,0) under S followed by R.

24. The diagram below shows a right pyramid VABCD with V as the vertex. The base of the pyramid is rectangle ABCD, WITH $ab = 4$ cm and $BC = 3$ cm. The height of the pyramid is 6cm.

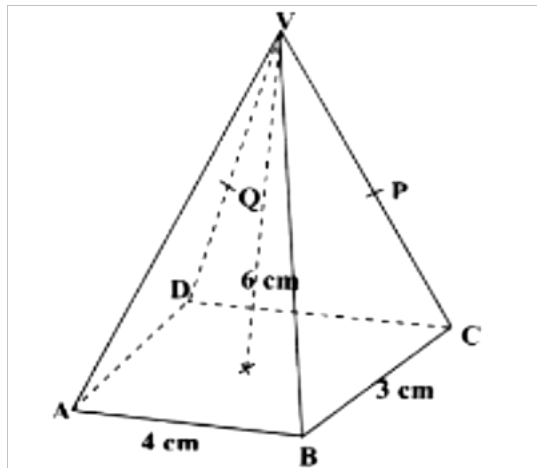

(a) Calculate the
(i) length of the projection of VA on the base

(ii) Angle between the face VAB and the base

(b) P is the mid- point of VC and Q is the mid – point of VD.
Find the angle between the planes VAB and the plane ABPQ

MATHEMATICS
K.C.S.E PAPER 121/ 2 2000
QUESTIONS

SECTION 1 (52 Marks)

1. Find equation of the perpendicular to the line $x + 2y - 4$ and passes through point $(2,1)$

2. A passenger noticed that she had forgotten her bag in a bus 12 minutes after the bus had left. To catch up with the bus, she immediately took a taxi which traveled at 95 km/h. The bus maintained an average speed of 75 km/h. Determine
 - (a) The distance covered by the bus in 12 minutes

 - (b) The distance covered by the taxi to catch up with the bus

3. Two sides of a triangles are 5 cm each and the angle between them is 120° . Calculate the area of the triangle.

4. A piece of wire P cm long is bent to form the shape shown in the figure below

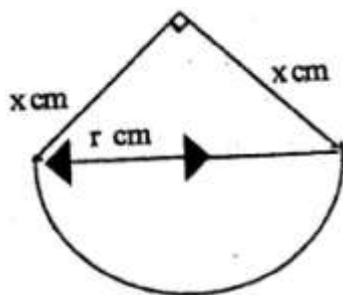

The figure consists of a semicircular arc of radius r cm and two perpendicular sides of length x cm each.

Express x in terms of P and r ,

Hence show that the area A cm², of the figures is given by $= \frac{1}{2} \pi r^2 + \frac{1}{8} (p - \pi r)^2$

5. The distance from a fixed point of a particular in motion at any time t seconds is given by

$$S = \frac{t^3 - 5t^2}{2} + 2t + 5$$

Find its:

- (a) Acceleration after 1 second
- (b) Velocity when acceleration is Zero

(c) Find all the integral value of x which satisfy the inequalities

$$2(2-x) < 4x - 9 < x + 11$$

7. Akinyi, Bundi, Cura, and Diba invested some money on a business in the ratio of 7: 9:10:1 respectively. The business realized a profit of Kshs 46,800. They shared 12% of the profit equally and the remainder in the ratio of their contributions.

Calculate the total amount received by Diba

8. Solve the equation $2 \sin^2(x-30^\circ) = \cos 60^\circ$ for $-180^\circ \leq x \leq 180^\circ$

9. A triangle is formed by the coordinates A (2, 1) B(4,1) and C(1,6). It is rotated clockwise through 90° about the origin. Find the coordinates of this image.

10. Three representatives are to be selected randomly from a group of 7 girls and 8 boys. Calculate the probability of selecting two girls and one boy.

11. Use the logarithms to evaluate
$$3\sqrt{\frac{1.23 \times 0.0089}{76.54}}$$

12. Find the value of x which satisfy the equation

$$5^{2x} - 6 \times 5^x + 5 = 0$$

13. Expand $(1 + x)^5$, hence, use the expansion to estimate $(1.04)^5$ correct to 4 decimal Places

14. In the figure below, BT is a tangent to the circle at B. AXCT and BXD are straight lines

AX = 6cm, CT = 8cm, BX = 4.8 cm and XD = 5cm.

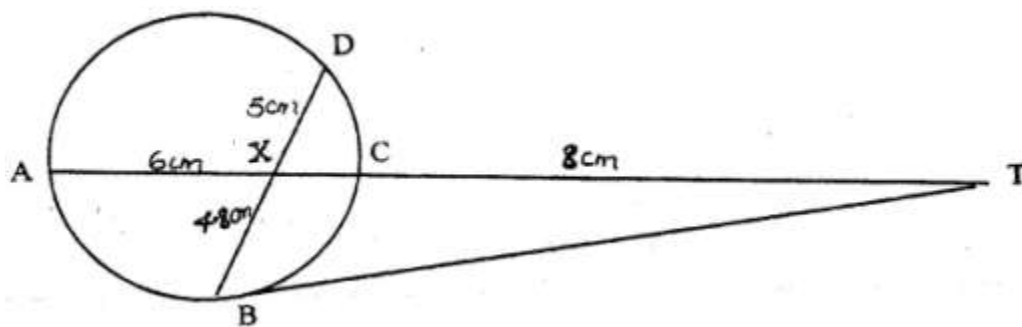

Find the length of

- (a) XC (b) BT

15. Make x the subject of the formula $p = \frac{xy}{z+x}^{1/2}$

16. The frequency distribution table below shows the weekly salary (K£) paid to workers in a factory

Salary (K£)	$50 \leq x < 100$	$100 \leq x < 150$	$150 \leq x < 250$	$250 \leq x < 350$	$350 \leq x < 500$
No. of workers	13	16	38	24	9

On the grid provided draw a histogram to respect the information shown above

SECTION II (48 Marks)
Answer any six questions from this section

17. A construction company requires to transport 144 tonnes of stones to sites A and B. The company pays Kshs 24,000 to transport 48 tonnes of stone for every 28 km. Kimani transported 96 tonnes to a site A, 49 km away.

- (a) Find how much he paid
- (b) Kimani spends Kshs 3,000 to transport every 8 tonnes of stones to site.
Calculate his total profit.
- (c) Achieng transported the remaining stones to sites B, 84 km away. If she made 44% profit, find her transport cost.

18. A rally car traveled from point R to point S. S is 128 km on a bearing 060° from R. The car then set off S at 9.30 am towards T at an average of 150 km/h. It was expected at T at 11.30 am. After traveling for 1 hour and 20 minutes it broke down at point P. The bearing of T and P from S is 300° .

Calculate the:

- (i) Distance from R to P
- (ii) Bearing of P and R
- (b) The repair took 10 minutes and the car set off to complete its journey to T. Find the speed at which car must now move to reach T on time.

20. The charge, C shillings per person for a certain seminar is partly fixed and partly inversely proportional to the total number N of people.
- Write down the expression for C in terms of N
 - When 100 people attended the charge is Kshs 8,700 per person while for 35 people the charge is Kshs. 10,000 per person
 - If a person had paid the full amount and does not attend, the fixed charge is refunded. A group of people paid but ten per cent of them did not attend. After the refund the organizer remained with Kshs 574,000. Find the number of people initially in the group.

21. The curve of the equation $y = 2x + 3x^2$, has $x = -2/3$ and $x = 0$ and x intercepts. The area bounded by the axis $x = -2/3$ and $x = 2$ is shown by the sketch below.

Find:

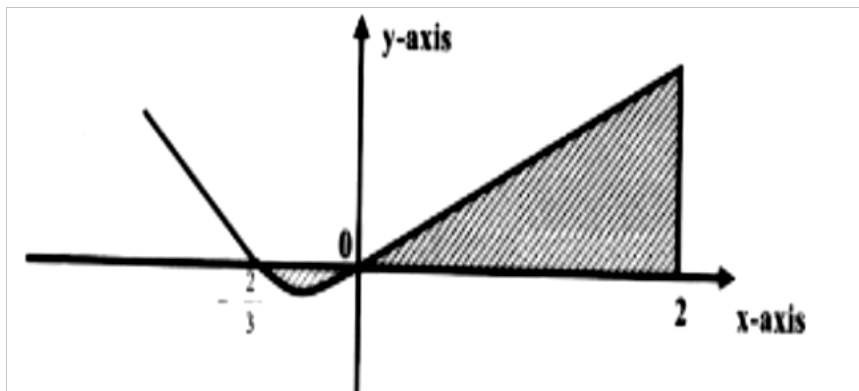

- $(2x + 3x^2) dx$
 - The area bounded by the curve x - axis, $x = -2/3$ and $x = 2$
22. The line segment BC given below is one side of triangle ABC
- Use a ruler and compasses to complete the construction of a triangle ABC in which $\angle ABC = 45^\circ$, $\angle AC = 5.6$ cm and angle BAC is obtuse
 - Draw the locus of point P such that P is equidistant from a point O and passes through the vertices of triangle.

- (c) Locate point D on the locus of P equidistant from lines BC and BO. Q lies in the region enclosed by lines BD, BO extended and the locus of P. Shade the locus of Q.

23. The diagram on the grid provided below shows a trapezium ABCD

On the same grid

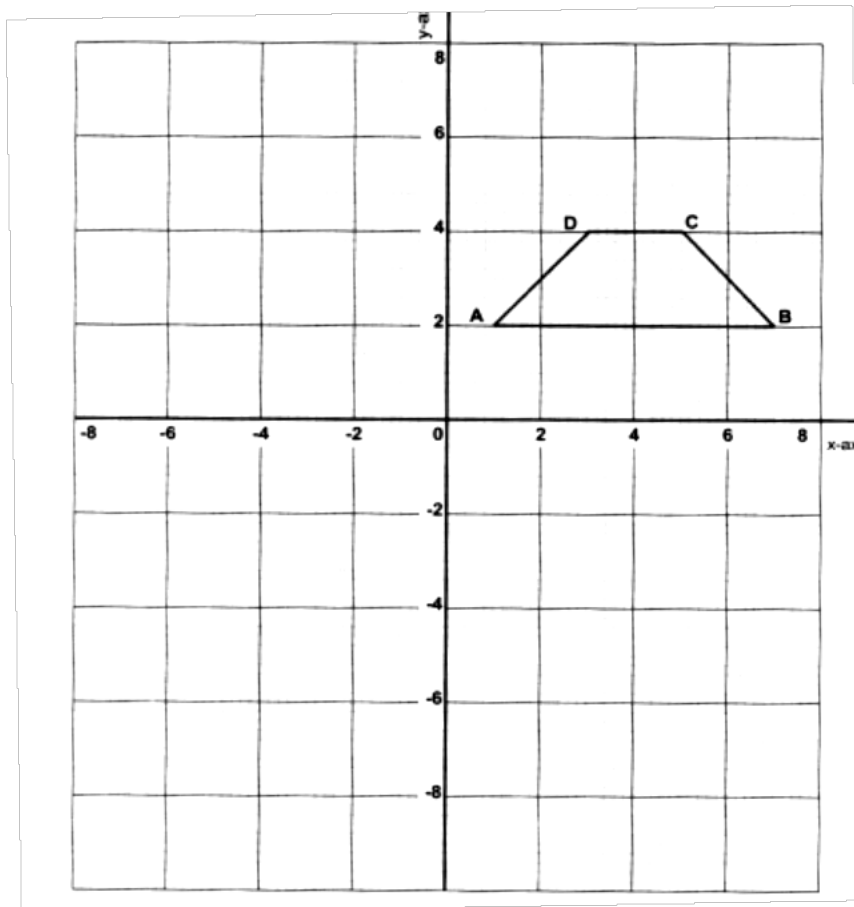

- (a) (i) Draw the image $A'B'C'D'$ of ABCD under a rotation of 90° clockwise about the origin .
- (ii) Draw the image of $A'B'C'D'$ under a reflection in line $y = x$. State coordinates of $A''B''C''D''$.
- (b) $A''B''C''D''$ is the image of $A'B'C'D'$ under the reflection in the line $x=0$. Draw the image $A'''B'''C'''D'''$ and state its coordinates.
- (c) Describe a single transformation that maps $A'''B'''C'''D'''$ onto ABCD.

24. A theatre has a seating capacity of 250 people. The charges are Kshs. 100 for an ordinary seat and Kshs 160 for a special seat. It cost Kshs 16,000 to stage a show and the theater must make a profit. There are never more than 200 ordinary seats and for a show to take place at least 50 ordinary seats must be occupied. The number of special seats is always less than twice the number of ordinary seats.
- (a) Taking x to be the number of ordinary seats and y the number of special seats write down all the inequalities representing the information above.
 - (b) On the grid provided, draw a graph to show the inequalities in (a) above
 - (c) Determine the number of seats of each type that should be booked in order to maximize the profit.

MATHEMATICS
K.C.S.E PAPER 121/ 2 2001
QUESTIONS

SECTION 1 (52 MKS)

Answer all the questions in this section.

1. Evaluate $\frac{1}{3}$ of $(2\frac{3}{4} - 5\frac{1}{2}) \times 3\frac{6}{7} \div \frac{9}{4}$
2. Solve for x in the equation $32^{(x-3)} \div 8^{(x-4)} = 64 \div 2^x$
3. Three people Odawa, Mliwa and Amina contributed money to purchase a flour mill. Odawa contributed of the total amount, Mliwa contributed of the remaining amount and Amina contributed the rest of the money. The difference in contribution between Mliwa and Amina was shs.40,000.

Calculate the price of the flour mill.

4. Two variables A and B are such that A varies partly as the square of B. Given that A = 30, when B = 9, and A = 16 when B = 14, Find A and B = 36.
5. The figure below shows a net of a prism whose cross – section is an equilateral triangle.

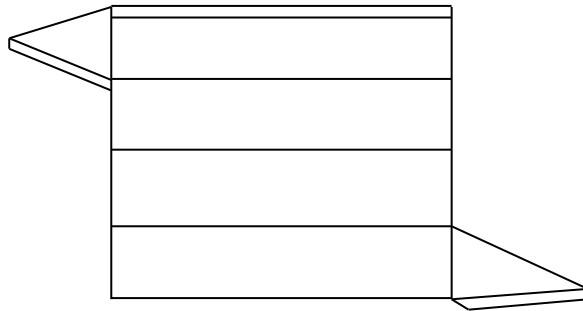

- a) Sketch the prism
 - b) State the number of planes of symmetry of the prism.
6. A telephone bill includes Ksh.4,320 for local calls, Ksh.3,260 for trunk calls and a rental charge of Kshs.2,080. A value added tax (V.A.T.) is then charge at 15%.
 7. A translation maps a point P (3,2) onto P' (95,5)
 - a) Determine the translation vector.
 8. Solve the equation $\log (x+24) - 2\log 3 = \log (9-2x)$

9. The table below shows the number of bags of sugar sold per week and their moving averages.

No. of bag as per week	340	330	x	342	350	345
Moving averages		331	332	Y	346	

- a) State the order of moving average
 b) Find the value of and y
10. Expand $(2 + x)^5$ in ascending powers of x up to the term in x^3
 Hence, approximate the value of $(2.03)^5$ to 4s.f.
11. A curve is given by the equation: $u = 5x^3 - 7x^2 + 3x + 2$ a)
 Gradient of the curve at $x = 1$
12. The figure represents a pentagon prism of length 12cm. The cross – section is a regular pentagon, centre O, whose dimensions are shown.

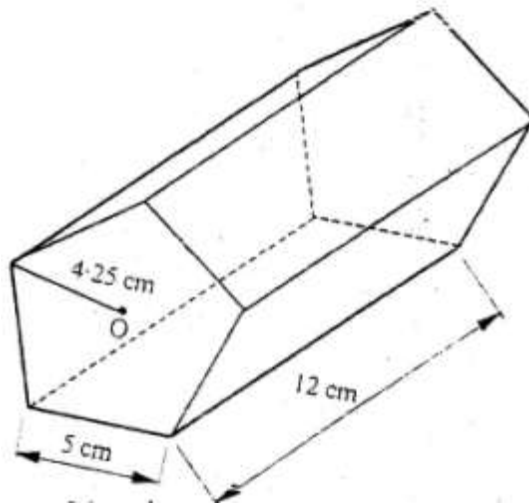

Find the total surface area of the prism.

13. Given that $\tan 75^\circ = 2 + \sqrt{3}$, find without using tables $\tan 15^\circ$ in the form $\frac{p+q\sqrt{m}}{m}$, where p, q and m are integers.

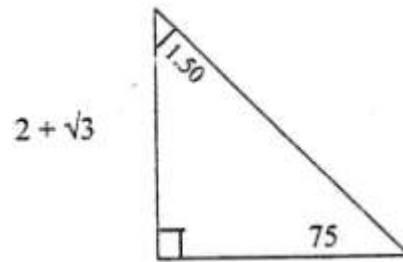

14. The diagram below represents a field PQR.

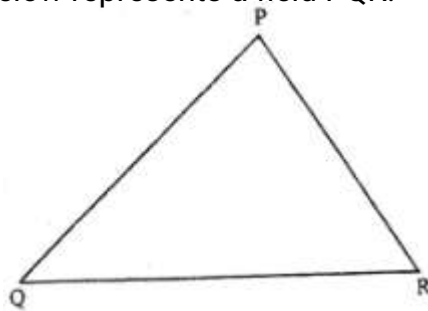

- Draw the locus of points equidistant from sides PQ and PR.
 - Draw the locus of points equidistant from points P and R.
 - a coin is lost within a region which is nearest to point P than to R and closer to side PR than to side PQ, shade the region where the coin can be located.
15. Solve the equation $4 \sin^2 \theta + 4 \cos \theta = 5$
For $0^\circ \leq \theta < 360^\circ$ give the answer in degrees

16. The diagram below shows the graph of:

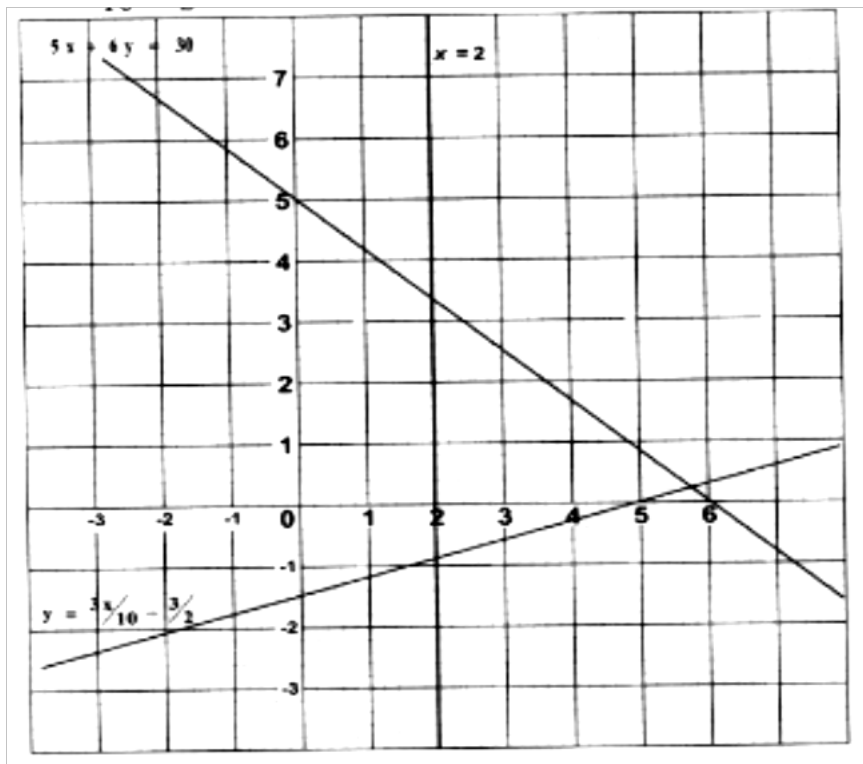

$$y \geq \frac{3}{10}x - \frac{3}{2}, 5x + 6y = 30 \text{ and } x = 2$$

By shading the unwanted region, determine and label the region R that satisfies the three inequalities.

$$y \geq \frac{3}{10}x - \frac{3}{2}, + 6y \geq 30 \text{ and } x \geq 2$$

SECTION II (48 Marks)
Answer any six questions in this section.

17. A helicopter is stationed at an airport H on a bearing 060° and 800km from another airport P. A third airport is J is on bearing of 140° and 1,200km from H.
- a) Determine:
 - i) Value of P
 - ii) The bearing of P from J
18. The marks obtained by 10 pupils in an English test were 15,14,13,12,P,16,11,13,12 and 17. The sum of the squares of the marks, $\sum x^2 = 794$

- a) Calculate the:
- Value of P
 - Standard deviation.
- b) If each mark is increased by 3, write down the:
- New mean
 - New standard deviation

19. The n th term of a sequence is given by $2n+3$

- Write the first four items of the sequence.
- Find S_{50} , the sum of the first terms of the sequence.
- Show that the sum of the first terms of the sequence is given by.

$$S_n = n^2 + 4n$$

Hence or otherwise find the first largest integral value of n such that.
 $S_n < 725$

20.
 - Distance from A and B
 - bearing B from A
21. a) Complete the table given below in the blank

X	0°	15°	30°	45°	60°	75°	90°	105°	120°	135°	150°	165°	180°
3 cos 2x	3	2.598	1.5	0	1.5	-3	-2.598	-1.5	0	2.598	3		
2 sin (2x +30°)	1		2	2.732	1	0		-1	-1.732	-2	-2.732	-2	1

- On the grid provided draw, on the same axis, the graph of $y = 3\cos 2x$ and $y = \sin(2x + 30^\circ)$ for $0^\circ \leq x \leq 180^\circ$. Take the scale: 1cm for 150 on the axis and 2cm for 1 unit on the y-axis.
- Use your graph to estimate the range of value of x for which $3 \cos 2x \leq 2\sin(2x+30^\circ)$.

Give your answer to the nearest degree.

22. The displacement x metres a particle after seconds given by.
 $x = t^3 - 2t^2 + 6t > 0$.

- Calculate the velocity of the particle in m/s when $t = 2$ seconds.
- When the velocity of the particle is zero, calculate its:-

- i) Displacement
- ii) Acceleration.

23. The diagram below represents a pillar made of cylindrical and regular hexagonal parts. The diameter and height of the cylindrical part are 1.4m and 1m respectively. The side of the regular hexagonal face is 0.4m and height of hexagonal part is 4m.

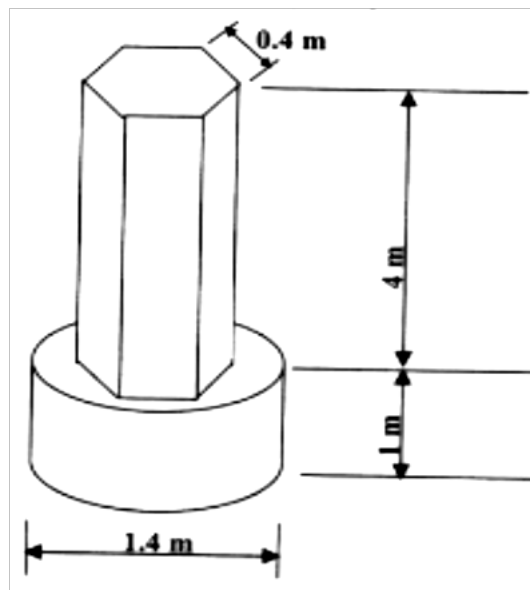

- a) Calculate the volume of the :
 - i) Cylindrical part
 - ii) Hexagonal part

- b) An identical pillar is to be built but with a hollow centre cross – section area of 0.25m^2 .
 The density of the material to be used to make the pillar is 2.4g/cm^3 .
 Calculate the mass of the new pillar.

24. Bot juice Company has two types of machines, A and B, for juice production. Type A machine can produce 800 litres per day while type B Machine produces 1,600 litres per day. Type A machine needs 4 operators and type B machine needs 7 operators.

At least 8,000litres must be produced daily and the total number of Operators should not exceed 41. There should be 2 more machines of each type.

Let x be the number of machines of type A and Y the number of machines for type B,

- Form all inequalities in x and y to represent the above information.
- On the grid provided below, draw the inequalities to shade the unwanted regions.

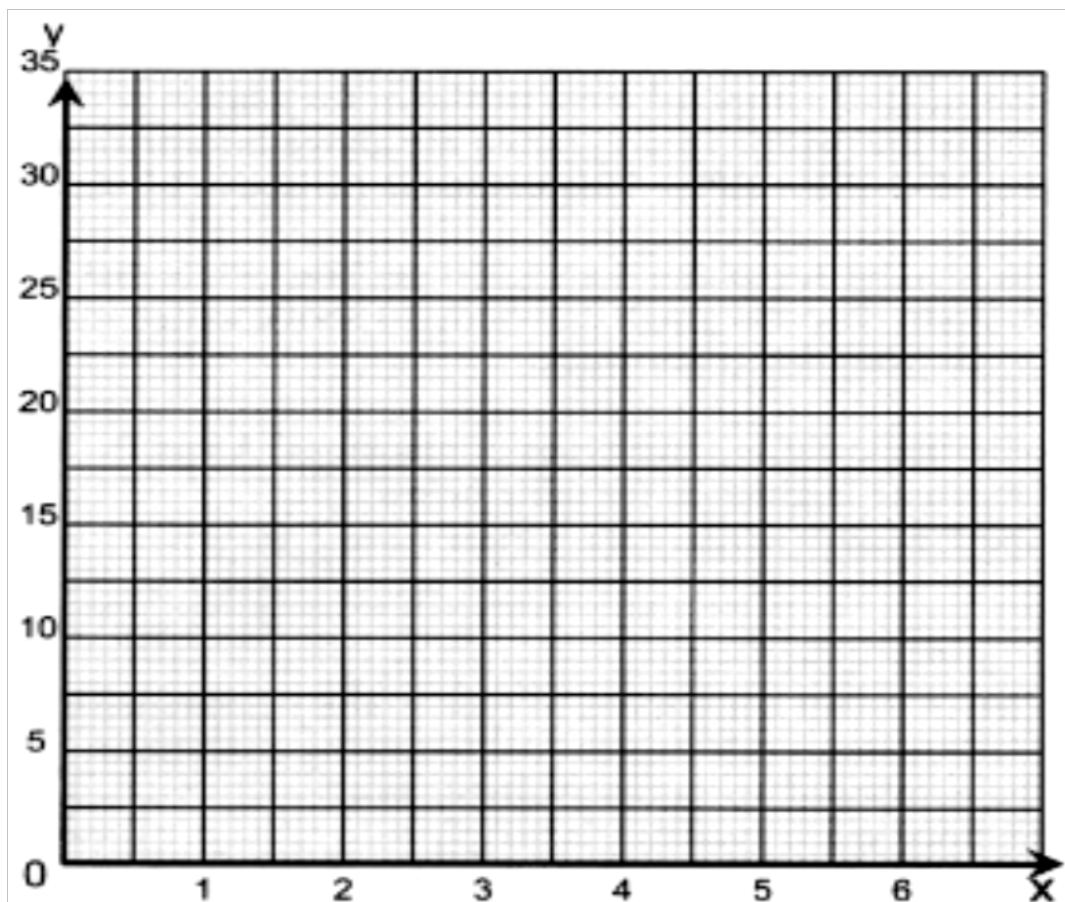

MATHEMATICS
K.C.S.E PAPER 121/ 2 2002
QUESTIONS

1. Use logarithms to evaluate
$$\frac{(0.0056)^{1/2}}{1.38 \times 27.42}$$
2. Kipketer can cultivate a piece of land in 7 hours while Wanjiku can do the same work in 5 hours. Find the time they would take to cultivate the piece of land when working together.
3. A triangular flower garden has an area of 28m². Two of its edges are 14 metres and 8 metres. Find the angle between the two edges.
4. Determine the inverse, T^{-1} of the matrix $\begin{pmatrix} 1 & 2 \\ 1 & -1 \end{pmatrix}$
5. A trader sells a bag of beans for shs. 2100 and that of maize at shs. 1200. He mixed beans and maize in the ratio 3:2. Find how much the trader should sell a bag of the mixture to realize the same profit.
6. The figure below represents a square based solid with a path marked on it.

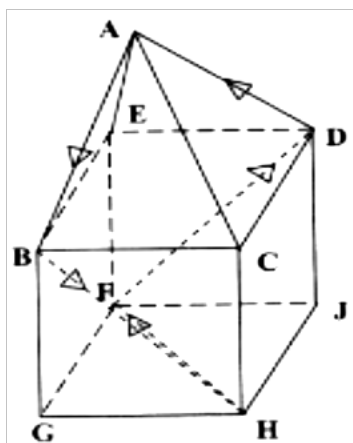

Sketch and label the net of the solid.

7. Solve for x in the equation
$$\frac{81^{2x} \times 27^x}{9^x} = 729$$
8. The sides of a triangle were measured and recorded as 8cm, 10cm and 15cm. Calculate the percentage error in perimeter, correct to 2 decimal places.

9. a) Expand $(a - b)^6$
 b) Use the first three term of the expansion in a (a) to find the approximate value of $(1.98)^6$
10. The coordinates of points O,P,Q and R are (0,0)(3,4) (11,6) and (8,2) respectively. A point T is such that vectors OT, QP and QR satisfy the vector equation. $OT = QP + \frac{1}{2} QR$.Find the coordinates of T.

11. Simply the expression $\frac{4x^2 - y^2}{2x^2 - 7xy + 3y^2}$

12 Atieno and Kamau started a business by contributing sh.25000 and sh.20,000 respectively. At the end of the year, they realized a profit of shs. 81,000.The profit was allocated to development, dividends and reserves in the ratio 4:5:6 respectively. The dividends were the shared in the ratio of their contribution. Calculate the dividends paid to Atieno.

13. The diagram below shows a circle ABCDE. The line FEG is a tangent to the circle at point E.
 Line DE is parallel to CG, $\angle DEC = 28^\circ$ and $\angle AGE = 32^\circ$

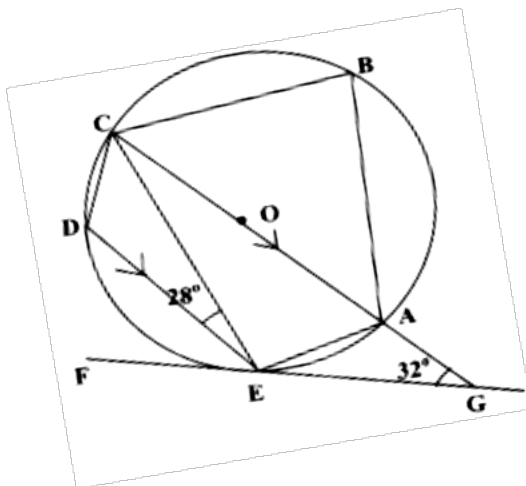

Calculate:

- (a) $\angle AEG$
 (b) $\angle ABC$
14. Each month, for 40 months, Amina deposited some money in a saving scheme. In the first month she deposited sh 500. Thereafter she increased her deposits by sh.50 every month. Calculate the:
 a) Last amount deposited by Amina
 b) Total amount Amina had saved in the 40 months.

15. In the diagram below, ABCD is a trapezium with AB parallel to DC. The diagonals AC and BD intersect at E.

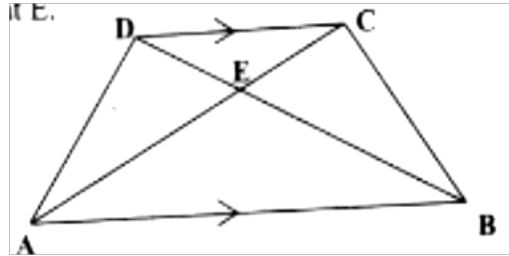

- a) Giving reasons show that triangle ABE is similar to triangle CDE. b) Giving that $AB = 3DC$, find the ratio of DB to EB.
16. The equation of a circle is given by $x^2 + 4x + y^2 - 5 = 0$. Find the radius and the center of the circle.
17. A bus travels from Nairobi to Kakamega and back. The average speed from Nairobi To Kakamega is 80km/hr while that from Kakamega to Nairobi is 50km/hr, the fuel consumption is 0.35 litres per kilometer and at 80km/h, the consumption is 0.3 litres per kilometer .

- Find i) Total fuel consumption for the round trip
ii) Average fuel consumption per hour for the round trip.

18. The table below shows Kenyan tax rates in a certain year

Income (K£ per annum)	Tax rates (Sh. Per £)
1 -4,512	2
4513 -9024	3
9025 – 13536	4
13537 – 18048	5
18049 -22560	6
Over 22560	6.5

In that year Muhando earned a salary of Ksh.16510 per month. He was entitled to a monthly tax relief of Kshs 960.

Calculate:

- a) Muhandos annual salary in K£
b) The monthly tax paid by muhando in Kshs.
19. The following distribution shows the masses to the nearest kilogram of

65 animals in a certain farm.

Mass Kg	26-30	31-35	36-40	41-45	46-50	51-55
frequency	9	13	20	15	6	2

a) On the grid provided draw the cumulative frequency curve for the given information.

b) Use the graph to find the:- i)

Median mass

ii) Inter-quartile range

iii) Percentage of animals whose mass is at least 42kg.

20. The figure VPQR below represents a model of a top of a tower. The horizontal base PQR is an equilateral triangle of side 9cm. The lengths of edges are $VP = VQ = VR = 20.5\text{cm}$. Point M is the mid point of PQ and $VM = 20\text{cm}$.

Point N is on the base and vertically below V.

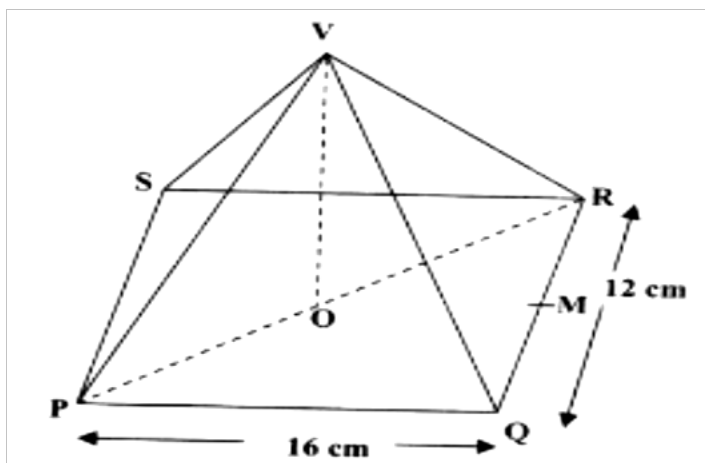

Calculate:

- a) i) Length of RM
ii) Height of model
iii) Volume of the model

b) The model is made of material whose density is $2,700\text{ kg/m}^3$. Find the Mass of the model.

21. The table below shows the values of x and corresponding values of y for a given curve.

X	0	$\frac{\pi}{12}$	$\frac{\pi}{6}$	$\frac{\pi}{4}$	$\frac{\pi}{3}$	$\frac{5\pi}{12}$	$\frac{\pi}{2}$
y	0	0.26	0.48	0.65	0.76	0.82	0.84

- a) Use the trapezium rule with seven ordinates and the values in the table only to estimate the area enclosed by the curve, x – axis and the line $x = \pi/2$ to four decimal places. (Take $\pi = 3.142$)
- b) The exact value of the area enclosed by the curve is known to be 0.8940. Find the percentage error made when the trapezium rule is used. Give the answer correct to two decimal places.
22. Four points B, C, Q and D lie on the same plane. Point B is 42km due south – west of point Q.
Point C is 50km on a bearing of S 60° E from Q. Point D is equidistant B, Q and C.

- a) Using the scale: 1 cm represents 10km, construct a diagram showing the positions of B, C, Q and D.

- Determines the: i) Distance between B and C
ii) Bearing of D from B.

23. a) Complete the table below, giving your values correct to 2 decimal place.

	0°	15°	30°	45°	60°	75°	90°	105°	120°	135°	150°	165°	180°
Tan θ°	0	0.27	0.58	1	1.73		a	3.73	1.73	-1		0.27	0
Sin θ°	0	0.5		1	0.87	0.5	0	-0.5		-1	0.87	-0.5	0

- b) Using the grid provided and the table in part (a) draw the graphs of $Y = \tan \theta$ and $y = \sin 2\theta$.
- c) Using your graphs, determine the range of values for which $\tan \theta > \sin 2\theta$ for $0^\circ \leq \theta \leq 90^\circ$.
24. The displacement s metre of a particle moving along straight line after t seconds is given by. $S = 3t + \frac{3}{2}t^2 - 2t^3$
- a) Find its initial acceleration
- b) Calculate: i) The time when the particle was momentarily at rest.
ii) Its displacement by the time it comes to rest momentarily
- c) Calculate the maximum speed attained.

MATHEMATICS
K.C.S.E PAPER 121/ 2 2003
QUESTIONS

1. Use logarithm tables to evaluate $\frac{2347 \times 0.4666}{\sqrt[3]{0.0924}}$
2. A shirt whose marked price in shs.800 is sold to a customer after allowing him a discount of 13%. If the trader makes a profit of 20%, find how much the trader paid for the shirt.

3. The table below shows the number of goals scored by a football team in 20 matches

Goals scored	0	1	2	3	4	5
Number of matches	5	6	4	3	1	1

Find:

- a) The mode (1mk)
- b) The mean number of goals (2mks)
4. A straight line passes through points A(-3,8) and B(3, -4). Find the equation of the straight line through(3,4) and parallel to AB. Give the answer in the form $y - mx + c$, and c are constants. (3mks)
5. Solve the equation ${}_{10}\log(6x - 2) - 1 = {}_{10}\log(x - 3)$ (3mks)

6. A train moving at an average speed of 72km/h takes 15 seconds to completely cross a bridge that is 80 metres long.
- a) Express 72km/h in metres per second (1mk)
 b) Find the length of the train in metres (2mks)

7. In the figure below, triangle A'B'C' is the image of triangle ABC under a rotation, centre O.

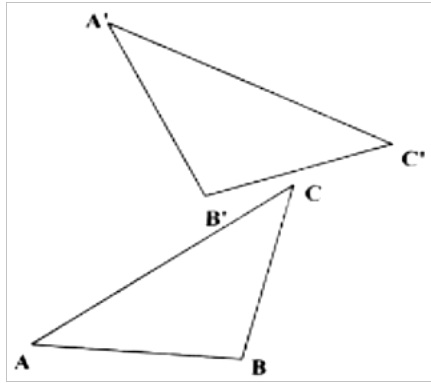

By construction, find the label the centre O of the rotation. Hence, determine the angle of the rotation.

8. Find the coordinates of the turning point of the curve whose equation is $y = 6 + 2x - 4x^2$
9. The surface area of a solid hemisphere is radius _____ your answer in terms of n. the volume of the solid, leaving
10. Given that $\sqrt[3]{a} = 1$ and $b = 13$, express $\sqrt[3]{23 - \sqrt{63}}$ in terms of a and b and simplify the answer.
11. a) Expand and simplify the binomial expression $(2 - x)^6$ (2mks)
 b) Use the expansion up to the term in x^2 to estimate 1.99^6 (2mks)
12. A mixed school can accommodate a maximum of 440 students. The number of girls must be at least 120 while the number of boys must exceed 150. Taking x to represent the number of boys and y the number of girls, write down all the inequalities representing the information above.

13. Machine A can do a piece of work in 6 hours while machine B can do the same work in 9 hours. Machine A was set to do the piece of work but after $3\frac{1}{2}$ hours, it broke down and machine B did the rest of the work. Find how long machine B took to do the rest of the work (3mks)
14. Three business partners Atieno, wambui and Mueni contributed sh 50,000, Sh.40,000 as sh 25,000 respectively to start a business. After some time, they realized a profit, which they decided to share in the ration of their contributions. If Mueni's share was sh 10.000, by how much was Atieno's share more than wambui's? (3mks)
15. A colony of insects was found to have 250 insects at the beginning. Thereafter the number of insects doubled every 2 days. Find how many insects there were after 16 days. (3mks)
16. A distance s metres of an object varies with time t seconds and partly with the square root of the time. Give that $s = 14$ when $t = 9$, write an equation connecting s and t .

SECTION II (48 MARKS)

Answer any six questions in this section.

17. Given the simultaneous equations
 $5x + y = 19$
 $-x + 3y = 9$
- a) Write the equations in matrix form. Hence solve the simultaneous equations. (5mks)
- b) Find the distance of the point of intersection for the line $5x + y = 19$ and $-x + 3y = 9$ from the point $(11, -2)$ (3mks)
18. A dealer has three grades of coffee X, Y and Z. Grade X costs sh 140 per kg, grade y costs sh160 per kg grade Z costs sh.256 per kg.
- a) The dealer mixes grades X and Y in the ration 5:3 to make a brand of coffee which sells at sh 180 per kg.

- b) The dealer makes a new brand by mixing the three grades of coffee. In the ratios $X:Y = 5:3$ and $Y:Z = 2:5$

Determine:

- i) The ratio $X: Y: Z$ in its simplest form (2mks)
ii) The selling price of the new brand of he has to make a 30% profit. (3mks)

19. A ship leaves port p for port R though port Q. Q is 200 km on a bearing of 220° from P. R is 420 km on the bearing of 140° from from Q.
- a) Using the scale 1:4,000,000, draw a diagram, showing the relative positions of the three ports P,Q, and R.
- b) By further drawing on the same diagram, determine how far R is to the east of p Distance = 3.5×40
- c) If the ship has sailed directly from P to R at an average speed of 40 knots, find how long it would have taken to arrive at R. (Take 1 nautical mile = 1.853 km)
20. Omondi makes two types of shoes: A and B. He takes 3 hours to make one pair of type A and 4 hours to make one pair of type B. He works for a maximum of 120 hours to x pairs of type A and Y pairs of type B. It costs him sh 400 to make a pair of type A and sh 150 to make a pair of type B.

His total cost does not exceed sh 9000. He must make 8 pairs of type A and more than 12 pairs of type B.

21. a) i) Find the coordinated of the stationary points on the curve $y = x^2 - 3x + 2$ (2mks)
ii) For each stationary point determine whether it is minimum or maximum.
- b) In the space provided below, sketch the graph of the Function $y = x^2 - 3x + 2$ (2mks)

22. The line PQ below is 8cm long and L is its midpoint
- a) i) Draw the locus of point R above line PQ such that the area of triangle PQR is 12cm^2 .

ii) Given that point R is equidistant from P and Q, show the position of point R..

b) Draw all the possible loci of a point T such that $\angle RQL = \angle RTL$. (4mks)

23. a) Complete the table below, giving your values correct to 2 decimal places.

X	0	15	30	45	60	75	90	105	120	135	150	165	180
Cos x	1	0.77	0.87	0.71	0.15	0.24	0	-0.26	-0.5	-0.17	0.5	0.87	1
Sin (x + 30)	0.5	0.17	0.87	0.97	0.10	0.97	0.87	0.71	0.5	-0.26	0	-0.26	-0.5

b) Using the grid provided draw, on the same axes, the graph of $y = \cos 2x$ and $y = \sin (x + 30^\circ)$ for $0^\circ < x < 180^\circ$

Take the scale: 1cm for 15° on the x axis
4cm for 1 unit on the y- axis.

(4mks)

c) Find the periods of the curve Y = axis

(1mks)

d) Using the graphs in part (b) above, estimate the solutions to the equation

$$\sin (x + 30^\circ) = \cos 2x$$

(4mks)

24. The figure below represents a right pyramid with vertex V and a rectangular base PQRS. $VP = VQ = VR = VS = 18\text{cm}$ and $PQ = 16\text{cm}$ and $QR = 12\text{cm}$. M and O are the midpoints of QR and PR respectively.

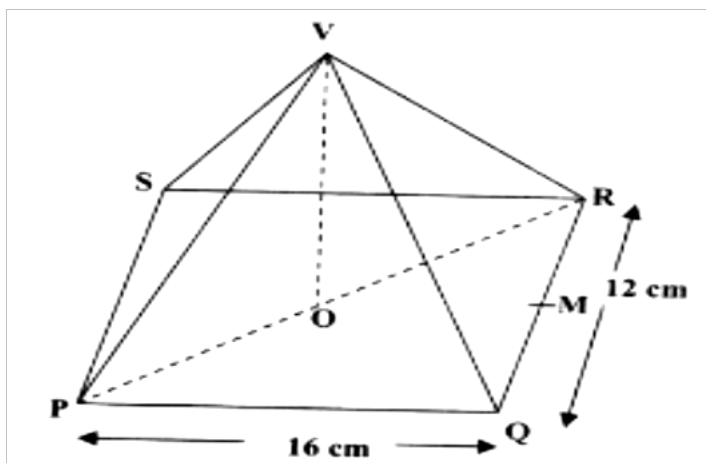

Find:

- a) The length of the projection of line VP on the plane PQES (2mks)
- b) The size of the angle between line VP and the plane PQRS. (2mks)
- c) The size of the angle between the planes VQR and PQRS. (2mks)

MATHEMATICS
K.C.S.E PAPER 121/ 2 2004
QUESTIONS

SECTION 1 (52 marks)

Answer all the questions in this section

1. Use logarithms to evaluate

$$\frac{34.33}{\sqrt{5.25 \times 0.042}}$$

2. The marked price of a car in a dealer's shop was Kshs 400,000. Wekesa bought the car at 8% discount. The dealer still made a profit of 15%. Calculate the amount of money the dealer had paid for the car.
3. Find the number of terms of the series $2 + 6 + 10 + 14 + 18 + \dots$ that will give a sum of 800.
4. Two trains T1 and T2 traveling in the opposite directions, on parallel tracks are just beginning to pass one another. Train T1 is 72 m long and traveling at 108 km/h. T2 is 78 m long and is traveling at 72 km/h.

Find the time, in seconds, the two trains take to completely pass one another

5. Evaluate without using mathematical tables, the expression
 $2 \log_{10} 5 - \frac{1}{2} \log_{10} 16 + 2 \log_{10} 40$
6. A student obtained the following marks in four tests during a school term: 60%, 75%, 48% and 66%. The tests were weighted as follows: 2, 1, 4 and 3 respectively. Calculate the student's weighted mean mark of the tests
7. Use matrices to solve the simultaneous equations
 $4x + 3y = 18$
 $5x - 2y = 11$
8. (a) Expand $(1 + x)^5$
(b) Use the first three terms of the expansion in (a) to find the approximate value of $(0.98)^5$
9. Make b the subject $a = \frac{bd}{b^2 - d}$

$$\frac{bd}{b^2 - d}$$

10. A group of 5 people can do a piece of work in 6 hours. Calculate the time a group of people. Working at half the rate of the first group would take to complete the same work.
11. In the figure below ABCDE is a cross- section of a solid. The solid has uniform cross- section.
Given that BG is a base edge of the solid, complete the sketch, showing the hidden edges with broken lines.

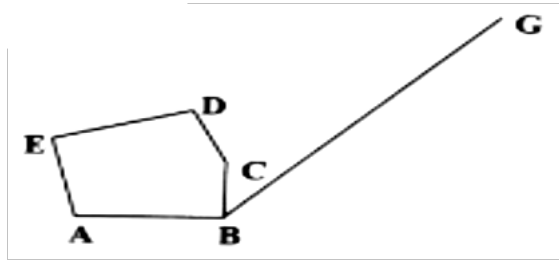

12. An industrialist has 450 litres of a chemical which is 70% pure. He mixes it with a chemical of the same type but 90% pure so as to obtain a mixture which is 75% pure.

Find the amount of the 90% pure chemical used

13. The gradient function of a curve is given $\frac{dy}{dx} = 3x^2 - 8x + 2$.
If the dx curve passes through the point, (0, 2), find its equation.
14. In this questions, mathematical tables should not be used
At Kenya bank buys sells foreign currencies as shown below:

	Buying (Kenya Shillings)	Selling (Kenya Shillings)
1 Euro	84.15	84.26
100 Japanese yen	65.37	65.45

A Japanese traveling from France arrives in Kenya with 5000 Euros, he converts all the 5000 Euros to Kenya Shillings at the bank.

Calculate the amount in Japanese yen, than he receives.

15. Form the three inequalities that satisfy the given region R.

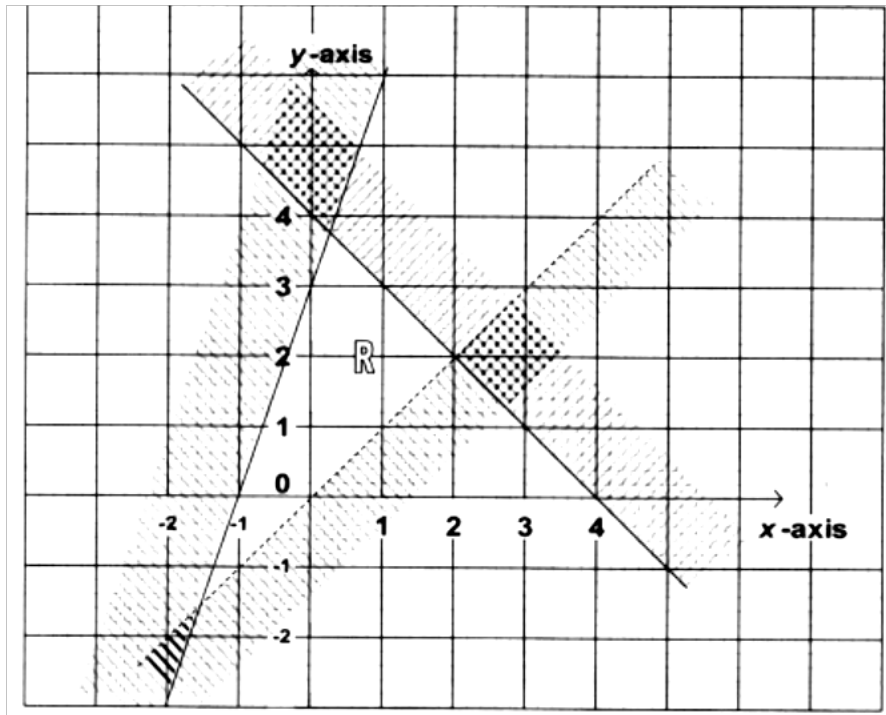

16. Without using mathematical tables, simplify

$$\frac{2}{3-\sqrt{7}} - \frac{2}{3+\sqrt{7}} \text{ in the form } a\sqrt{b}$$

SECTION II (48 Marks)

Answer any six questions from this section

17. Farmer has two tractors A and B. The tractors, working together can plough a farm in $2\frac{1}{2}$ h. One day, the tractors started to plough the farm together. After 1 h 10 min tractor B broke down but A continued alone and completed the job after a further 4 h.

Find:

- The fraction of the job done by the tractors, working together for one hour
- The fraction of the job done by tractor A and B broke down
- The time each tractor working alone would have taken to plough the farm.

18. The table below shows the ages in years of 60 people who attended a conference.

Age in years	30 – 39	40- 49	50- 59	60- 69	70-79
Number of people	10	12	18	17	3

Calculate

- (a) The inter-quartile range of the data
(b) The percentage of the people in the conference whose ages were 54.5 years and below.
19. For electricity posts, A, B, C, and D stand on a level ground such that B is 21 m on a bearing of 060° from A, C, is 15 m to the south of B and D is 12 m on a bearing of 140° from A.
- (a) (i) Using scale of 1 cm of 1 cm to represents 3 metres, draw a diagram to show the relative positions of the posts
(ii) Find the distances and the bearing of C from D
- (b) The height of the post at A is 8.4m. On a separate scale drawing, mark and determine the angle of depression of the foot of the post at C from the top of the top of the post at A.
20. (a) Given that the matrix $A = \begin{pmatrix} 2 & 3 \\ 3 & 4 \end{pmatrix}$ Find A^{-1} the inverse of A
- (b) Kimtai bought 200 bags of sugar and 300 bags of rice for a total of Kshs. 850,000.
Buya bought 90 bags of sugar and 120 bags of rice for a total of Kshs. 360,000.
If the price of a bag of sugar is Kshs x and that of rice is Kshs. Y,
- (i) Form two equations to represent the information above
(ii) Use the matrix A^{-1} to find the prices of one bag of each item.
- (c) Kali bought 225 bags of sugar and 360 bags of rice. He was given a total discount of Kshs. 33,300.
If the discount on the price of a bag of rice was 2%, calculate the percentage discount on the price of a bag of sugar.

21. Triangle ABC is the image of triangle PQR under the transformation $M = \begin{pmatrix} 2 & 4 \\ 0 & 2 \end{pmatrix}$
 Where P, Q and R map onto A, B, and C respectively.

(a) Given the points P(5, -1), Q(6, -1) and R (4, -0.5), draw the triangle ABC on the grid provided below.

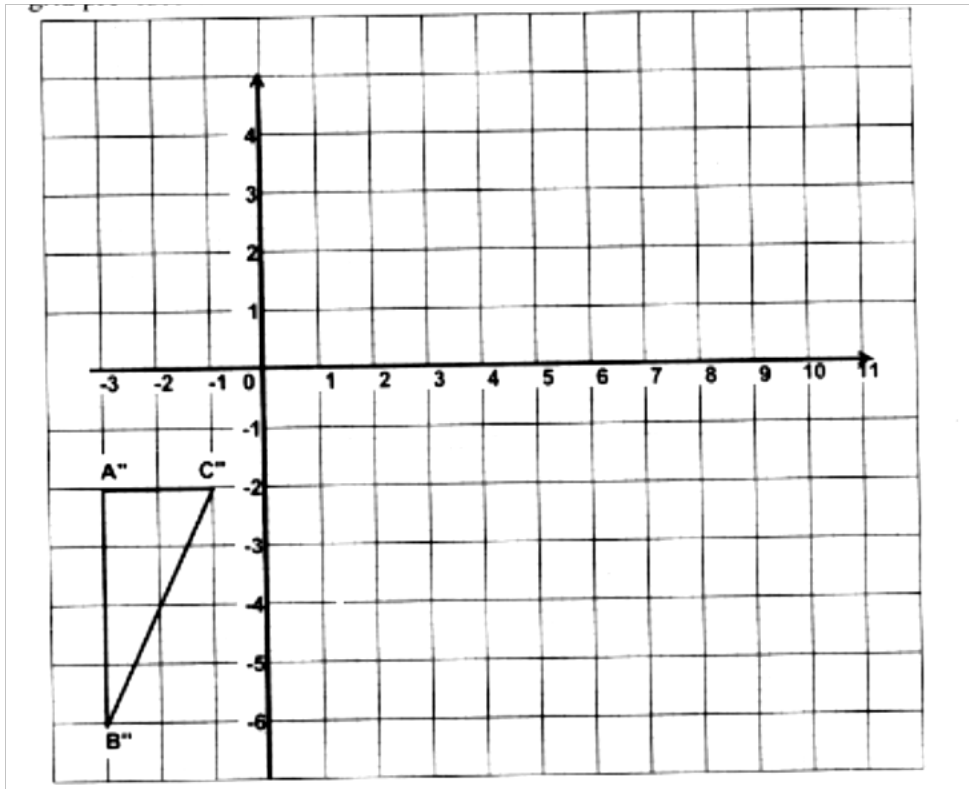

(b) Triangle ABC in part (a) above is to be enlarged scale factor 2 with centre at (11, -6) to map onto A'B'C'.
 Construct and label triangle A'B'C' on the grid above.

(c) By construction find the coordinates of the centre and the angle of rotation which can be used to rotate triangle A'B'C' onto triangle A''B''C'', shown on the grid above.

22. A particle moves in a straight line. It passes through point O at $t = 0$ with velocity $V = 5\text{m/s}$. The acceleration $a\text{ m/s}^2$ of the particle at time t seconds after passing through O is given by $a = 6t + 4$

(a) Express the velocity v of the particle at time t seconds in terms of t

(b) Calculate

(i) The velocity of the particle when $t = 3$

(ii) The distance covered by the particle between $t = 2$ and $t = 4$

23. Three quantities P, Q and R are such that P varies directly as the square of Q and inversely as the square root of R.

(a) Given that $P = 20$ when $Q = 5$ and $R = 9$, find P when Q and $R = 25$

(b) If Q increases by 20% and decreases by 36%, find the percentage increase in P.

24. The figure below shows a model of a roof with a rectangular base PQRS $PQ = 32$ cm and $QR = 14$ cm. The ridge $XY = 12$ cm and is centrally placed. The faces PSX and QRY are equilateral triangles M is the midpoint of QR.

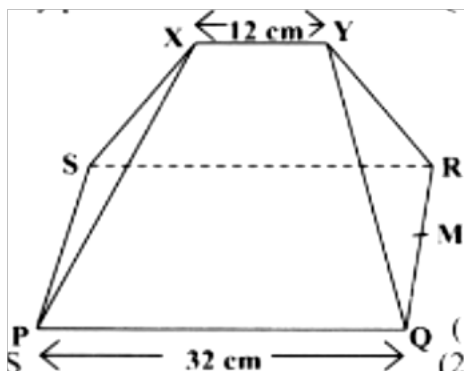

Calculate

(a) (i) the length of YM

(ii) The height of Y above the base PQRS

(b) The angle between the planes RSXY and PQRS

(c) The acute angle between the lines XY and

MATHEMATICS

K.C.S.E PAPER 121/ 2 2005

QUESTIONS

SECTION I (52 Marks).
Answer all questions in this section

1. Find the value of y in the equation (3mks)

$$\frac{243 \times 3^{2y}}{729 \times 3^y \div 3^{(2y-1)}} = 81$$

2. Without using mathematical Tables, simplify (3 mks)

$$\frac{\sqrt{63} + \sqrt{72}}{\sqrt{32} + \sqrt{28}}$$

3. In a fund- raising committee of 45 people, the ratio of men to women is 7: 2.
 Find the number of women required to join the existing committee so that
 the ratio of men to women is changed to 5: 4 (3
 mks)
4. The diagram below is a part of a figure which has rotational symmetry of
 order 4 about O.

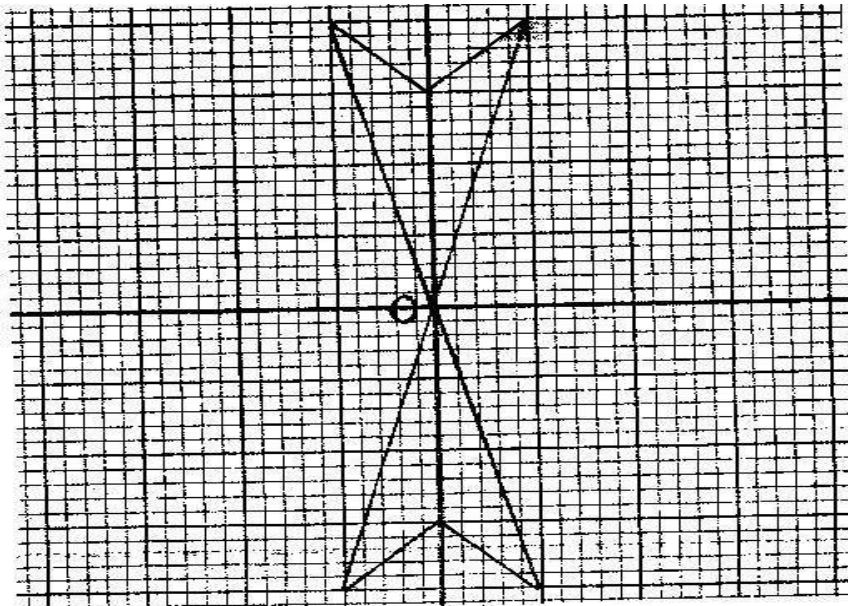

- a) Complete the figure (1 mk)
- b) Draw all the lines of symmetry of the completed figure

(2 mks)

5. The first three consecutive terms of a geometrical progression are 3, x and $5^{1/3}$. Find the value of x. (2 mks)
6. Pipe a can fill an empty water tank in 3 hours while, pipe B can fill the same tank in 6 hours, when the tank is full it can be emptied by pipe C in 8 hours. Pipes A and B are opened at the same time when the tank is empty. If one hour later, pipe C is also opened, find the total time taken to fill the tank (4 mks)
7. Find, without using Mathematical Tables the values of x which satisfy the equation
 $\text{Log}^2 (x^2 - 9) = 3 \log_2^{2+1}$ (4 mks)
8. The volumes of two similar solid cylinders are 4752 cm^3 and 1408 cm^3 . If the area of the curved surface of the smaller cylinder is 352 cm^2 , find the area of the curved surface of the larger cylinder. (4 mks)
9. Given that $\text{Cos } 2x^\circ = 0.8070$, find x when $0^\circ < x < 360^\circ$ (4 mks)
10. A salesman earns a basic salary of Kshs. 9000 per month In addition he is also paid a commission of 5% for sales above Kshs 15000 In a certain month he sold goods worth Kshs. 120, 000 at a discount of $2 \frac{1}{2} \%$ Calculate his total earnings that month (3 mks)
11. Successive moving averages of order 5 for the numbers 9, 8.2, 6.7,5.4, 4.7 and k are A and B. Given that $A - B = 0.6$ find the value of k.
12. Two lines L1 and L2 intersect at a point P. L1 passes through the points (-4,0) and (0,6). Given that L2 has the equation: $y = 2x - 2$, find, by calculation, the coordinates of P. (3 mks)
13. Expand and simplify $(3x - y)^4$
Hence use the first three terms of the expansion to approximate the value of $(6-0.2)^4$ (4 mks)
14. The density of a solid spherical ball varies directly as its mass and inversely as the cube of its radius
When the mass of the ball is 500g and the radius is 5 cm, its density is 2 g

per cm³

Calculate the radius of a solid spherical ball of mass 540 density of 10g per cm³

15. The figure below represents below represents a prism of length 7 cm
AB = AE = CD = 2 cm and BC – ED = 1 cm

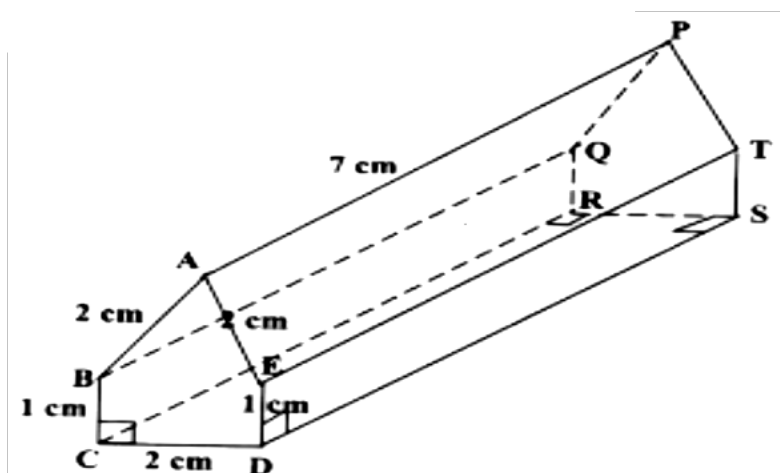

Draw the net of the prism

(3 mks)

16. A stone is thrown vertically upwards from a point O After t seconds, the stone is S metres from O Given that $S = 29.4t - 4.9t^2$, find the maximum height reached by the stone

(3

mks)

SECTION II (48 marks)

Answer any six questions in this section

17. A curve is represented by the function $y = \frac{1}{3}x^3 + x^2 - 3x + 2$

(a) Find $\frac{dy}{dx}$

mk)

(1

(b) Determine the values of y at the turning points of the curve

$$y = \frac{1}{3}x^3 + x^2 - 3x + 2$$

mks)

(4

18. Triangles ABC and A||B||C|| are drawn on the Cartesian plane provided.
Triangle ABC is mapped onto A||B||C|| by two successive transformations

$$R = \begin{bmatrix} a & b \\ c & d \end{bmatrix} \text{ followed by } P = \begin{bmatrix} 0 & -1 \\ 1 & 0 \end{bmatrix}$$

- (a) Find R (4 mks)
- (b) Using the same scale and axes, draw triangles A'B'C', the image of triangle ABC under transformation R (2 mks)
- (c) Describe fully, the transformation represented by matrix R (2 mks)
19. Abdi and Amoit were employed at the beginning of the same year. Their annual salaries in shillings progressed as follows:
- Abdi: 60,000, 64 800, 69, 600
Amoit 60,000, 64 800, 69 984
- (a) Calculate Abdi's annual salary increment and hence write down an expression for his annual salary in his nth year of employment (2 mks)
- (b) Calculate Amoit's annual percentage rate of salary increment and hence write down an expression for her salary in her ninth year of employment. (2 mks)
- (c) Calculate the differences in the annual salaries for Abdi and Amoit in their 7th year of employment (4 mks)
20. (a) BCD is a rectangle in which AB = 7.6 cm and AD = 5.2 cm. draw The rectangle and construct the locus of a point P within the rectangle such that P is equidistant from CB and CD (3 mks)
- (b) Q is a variable point within the rectangle ABCD drawn in (a) above such that $60^\circ \leq \angle AQB \leq 90^\circ$
- On the same diagram, construct and show the locus of point Q, by leaving unshaded, the region in which point Q lies
21. (a) complete the table below, giving your values correct to 2 decimal places (2 mks)

x°	0	30	60	90	120	150	180
$2 \sin x^\circ$	0	1		2		1	
$1 - \cos x^\circ$			0.5	1			

- (b) On the grid provided, using the same scale and axes, draw the graphs of $y = \sin x^\circ$ and $y = 1 - \cos x^\circ \leq x \leq 180^\circ$

Take the scale: 2 cm for 30° on the x- axis
2 cm for 1 unit on the y- axis

- (c) Use the graph in (b) above to

- (i) Solve equation

$$2 \sin x^\circ + \cos x^\circ = 1$$

(1 mk)

- (ii) Determine the range of values x for which $2 \sin x^\circ > 1 - \cos x^\circ$ (1 mk)

22. A boat at point x is 200 m to the south of point Y . The boat sails X to another point Z . Point Z is 200m on a bearing of 310° from X , Y and Z are on the same horizontal plane.

- (a) Calculate the bearing and the distance of Z from Y

(3 mks)

- (b) W is the point on the path of the boat nearest to Y .

Calculate the distance WY

(2

mks)

- (c) A vertical tower stands at point Y . The angle of point X from the top of the tower is 60° calculate the angle of elevation of the top of the tower from W

(3 mks)

23. The diagram below represents a cuboid $ABCDEFGH$ in which $FG = 4.5$ cm, $GH = 8$ cm and $HC = 6$ cm

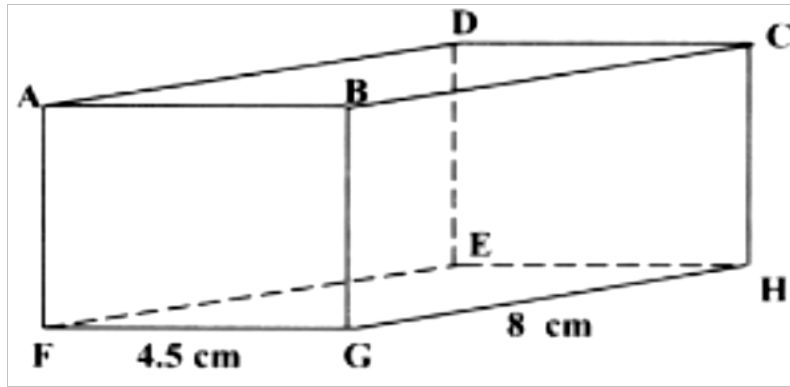

Calculate:

- (a) The length of FC (2 mks)
- (b) (i) the size of the angle between the lines FC and FH (2 mks)
- (ii) The size of the angle between the lines AB and FH (2 mks)
- (c) The size of the angle between the planes ABHE and the plane FGHE (2 mks)

24. Diet expert makes up a food production for sale by mixing two ingredients N and S. One kilogram of N contains 25 units of protein and 30 units of vitamins. One kilogram of S contains 50 units of protein and 45 units of vitamins.

If one bag of the mixture contains x kg of N and y kg of S

- (a) Write down all the inequalities, in terms of x and representing the information Above (2 mks)
- (b) On the grid provided draw the inequalities by shading the unwanted regions (2 mks)
- (c) If one kilogram of N costs Kshs 20 and one kilogram of S costs Kshs 50, use the graph to determine the lowest cost of one bag of the mixture (3 mks)

MATHEMATICS
K.C.S.E PAPER 121/ 2 2006
QUESTIONS

SECTION 1 (50 Marks)

1. In this question, show all the steps in your calculations, giving your answers at each stage

Use logarithms, correct to 4 decimal places, to evaluate (4 mks)

$$3 \frac{36.72 \times (0.46)^2}{185.4}$$

2. Make s the subject of the formula (4 mks)

$$\sqrt{p} = r\sqrt{1-as^2}$$

3. In the figure below R, T and S are points on a circle centre O PQ is a tangent to the circle at T. POR is a straight line and $\angle QPR = 200^\circ$

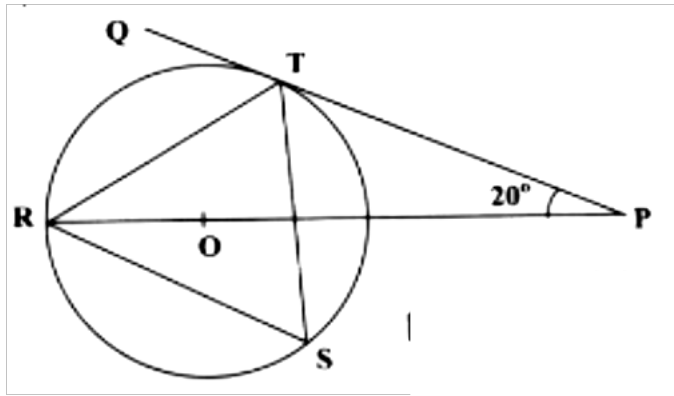

Find the size of $\angle RST$ (2 mks)

4. By correcting each number to one significant figure, approximate the value of 788×0.006 .
Hence calculate the percentage error arising from this approximation (3 mks)

5. The data below represents the ages in months at which 6 babies started walking: 9, 11, 12, 13, 11, and 10. Without using a calculator, find the exact value of the Variance (3 mks)

6. Without using a calculator or mathematical tables, simplify $\frac{\sqrt[3]{2-\sqrt{3}}}{\sqrt[2]{3-\sqrt{2}}}$ (3 mks)

7. The figure below shows a circle centre O and a point Q which is outside the circle

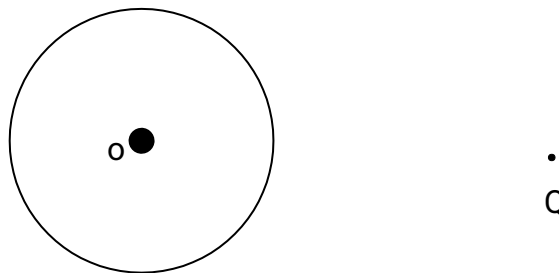

Using a ruler and a pair of compasses, only locate a point on the circle such that angle OPQ = 90 degrees (2 mks)

8. The table below is a part of tax table for monthly income for the year 2004

Monthly taxable income In (kshs)	Tax rate percentage (%) in each shillings
Under Kshs 9681	10%

From Kshs 9681 but under 18801	15%
From Kshs 18801 but 27921	20%

In the tax year 2004, the tax of Kerubo's monthly income was Kshs 1916
Calculate Kerubos monthly income (3 mks)

9. Given that $q \mathbf{i} + \frac{1}{3} \mathbf{j} + \frac{2}{3} \mathbf{k}$ is a unit vector, find q (2 mks)

10. The points which coordinates (5,5) and (-3,-1) are the ends of a diameter of a circle centre A Determine:

(a) the coordinates of A (1 mk)

(b) The equation of the circle, expressing it in form $x^2 + y^2 + ax + by + c = 0$ where a, b, and c are constants (3 mks)

11. Use binomial expression to evaluate (4 mks)

$$\left[2 + \frac{1}{\sqrt{2}}\right]^2 + \left[2 - \frac{1}{\sqrt{2}}\right]^2$$

12. Three quantities t, x and y are such that t varies directly as x and inversely as the square root of y. Find the percentage in t if x decreases by 4% when y increases by 44% (4 mks)

13. The figure below is drawn to scale. It represents a field in the shape of an equilateral triangle of side 80m

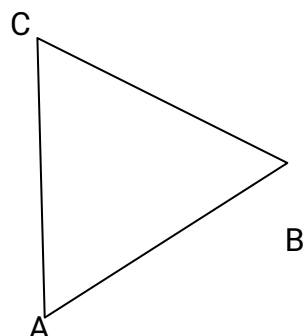

The owner wants to plant some flowers in the field. The flowers must be at most, 60m from A and nearer to B than to C. If no flower is to be more than 40m from BC, show by shading, the exact region where the flowers may be planted (4 mks)

14. The table shows some corresponding values of x and y for the curve represented by $Y = \frac{1}{4}x^3 - 2$

X	-3	-2	-1	0	1	2	3
Y	-8.8	-4	-2.3	-2	-1.8	0	4.8

On the grid provided, draw the graph of $y = \frac{1}{4}x^2 - 2$ for $-3 \leq x \leq 3$. Use the graph to estimate the value of x when $y = 2$ (3 mks)

15. A particle moving in a straight line passes through a fixed point O with a velocity of 9m/s. The acceleration of the particle, t seconds after passing through O is given by $a = (10 - 2t) \text{ m/s}^2$. Find the velocity of the particle when $t = 3$ seconds (3 mks)

16. Two places P and Q are at (360N, 1250W) and (360N, 1250W) and (360 N, 1250W) and (360 N, 550E) respectively. Calculate the distance in nautical miles between P and Q measured along the great circle through the North pole. (3 mks)

SECTION II (50 marks)
Answer any five questions

17. A certain sum of money is deposited in a bank that pays simple interest at a certain rate. After 5 years the total amount of money in an account is Kshs 358 400. The interest earned each year is 12 800

Calculate

(i) the amount of money which was deposited (2 mks)

(ii) the annual rate of interest that the bank paid (2 mks)

(b) A computer whose marked price is Kshs 40,000 is sold at Kshs 56,000 on hire purchase terms.

(i) Kioko bought the computer on hire purchase term. He paid a deposit

For marking schemes, Whatsapp/contact-0746711892

of 25% of the hire purchase price and cleared the balance by equal monthly installments of Kshs 2625

Calculate the number of installments
mks) (3

(ii) Had Kioko bought the computer on cash terms he would have been allowed a discount of $12\frac{1}{2}\%$ on marked price. Calculate the difference between the cash price and the hire purchase price and express as a percentage of the cash price.

18. A garden measures 10m long and 8 m wide. A path of uniform width is made all round the garden. The total area of the garden and the paths is 168 m^2 .

(a) Find the width of the path (4 mks)

(b) The path is to covered with square concrete slabs. Each corner of the path is covered with a slab whose side is equal to the width of the path.

The rest of the path is covered with slabs of side 50 cm. The cost of making each corner slab is Kshs 600 while the cost of making each smaller slab is Kshs 50.

Calculate

(i) The number of smaller slabs used
mks) (3

19. Triangle ABC is shown on the coordinates plane below

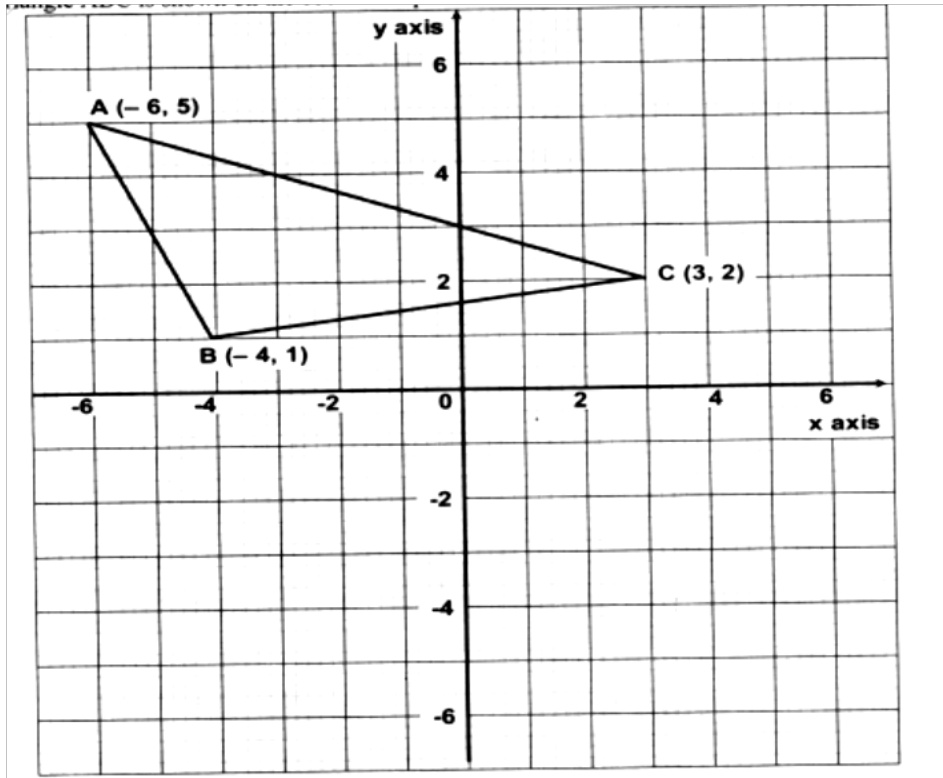

(a) Given that A (-6, 5) is mapped onto A' (6, -4) by a shear with y-axis invariant

(i) Draw triangle A'B'C', the image of triangle ABC under the shear

(3 mks)

(ii) Determine the matrix representing this shear

(2

mks)

(b) Triangle A B C is mapped on to A'' B'' C'' by a transformation defined by

the matrix $\begin{bmatrix} -1 & 0 \\ 1\frac{1}{3} & -1 \end{bmatrix}$

(i) Draw triangle A'' B'' C''

(3mks)

(ii) Describe fully a single transformation that maps ABC onto A''B''C'' (3mks)

20. (a) Two integers x and y are selected at random from the integers 1 to 8. If the same integer may be selected twice, find the probability that

(i) $|x-y| = 2$

(2 mks)

(ii) $|x-y|$ is more

(2 mks)

(iii) $x > y$

(2 mks)

(b) A die is biased so that when tossed, the probability of a number r showing up, is given by $p \propto Kr$ where K is a constant and $r = 1, 2, 3, 4, 5$ and 6 (the number on the faces of the die)

(i) Find the value of K (2 mks)

(ii) if the die is tossed twice, calculate the probability that the total score is 11 (2 mks)

21. A solution whose volume is 80 litres is made 40% of water and 60% of alcohol. When litres of water are added, the percentage of alcohol drops to 40%

(a) Find the value of x (4 mks)

(b) Thirty litres of water is added to the new solution. Calculate the percentage

(c) If 5 litres of the solution in (b) is added to 2 litres of the original solution, calculate in the simplest form, the ratio of water to that of alcohol in the resulting solution (4 mks)

22. The product of the first three terms of geometric progression is 64. If the first term is a , and the common ratio is r .

(a) Express r in terms of a (3 mks)

(b) Given that the sum of the three terms is 14

(i) Find the value of a and r and hence write down two possible sequences each up to the 4th term.

(ii) Find the product of the 50th terms of two sequences (2 mks)

23. Mwanjoki flying company operates a flying service. It has two types of aeroplanes. The smaller one uses 180 litres of fuel per hour while the bigger one uses 300 litres per hour.

The fuel available per week is 18,000 litres. The company is allowed 80 flying hours per week while the smaller aeroplane must be flown for y hours per week.

(a) Write down all the inequalities representing the above information (3 mks)

(b) On the grid provided, draw all the inequalities in a) above

by shading the unwanted regions
(3 mks)

- (c) The profits on the smaller aeroplane is Kshs 4000 per hour while that on the bigger one is Kshs 6000 per hour

Use the graph drawn in (b) above to determine the maximum profit that the company made per week.
(3 mks)

24. The diagram below shows a sketch of the line $y = 3x$ and the curve $y = 4 - x^2$ intersecting at points P and Q.

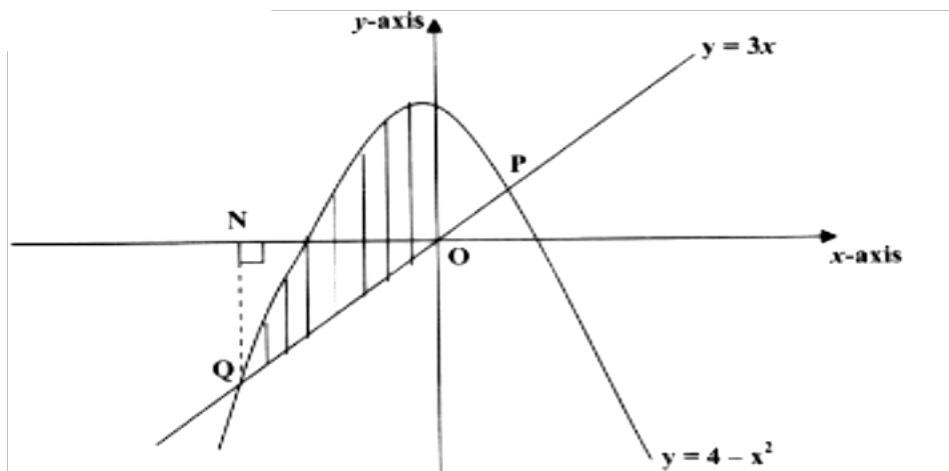

- a) Find the coordinates of P and Q
- (b) Given that QN is perpendicular to the x-axis at N, calculate
- (i) The area bounded by the curve $y = 4 - x^2$, the x-axis and the line QN (2 mks)
- (ii) The area of the shaded region that lies below the x-axis
- (iii) The area of the region enclosed by the curve $y = 4 - x^2$, the line $y = 3x$ and the y axis

The two dispute the common boundary with each claiming boundary along different smooth curves coordinates (x, y) and (x, y^2) in the table below, represents points on the boundaries as claimed by Kazungu Ndoe respectively.

x	0	1	2	3	4	5	6	7	8	9
y1	0	4	5.7	6.9	8	9	9.8	10.6	11.3	12
y2	0	0.2	0.6	1.3	2.4	3.7	5.3	7.3	9.5	12

- (a) On the grid provided above draw and label the boundaries as claimed by
For marking schemes, Whatsapp/contact-0746711892

MATHEMATICS
K.C.S.E PAPER 121/ 2 2007
QUESTIONS

SECTION 1 (50 Mks)

Answer all the questions in this section

1. Using logarithm tables, evaluate $\frac{0.032 \times 14.26^{2/3}}{0.006}$ (3 mks)
2. Given that $y = \frac{2x - z}{X + 3z}$, express x in terms of y and z (3 mks)
3. Solve the equation $3 \cos x = 2 \sin 2x$, where $0^\circ \leq x \leq 360^\circ$ (4 mks)
4. (a) Expand the expression $\left(1 + \frac{1}{2}x\right)^5$ in ascending powers of x , leaving the coefficients as fractions in their simplest form (2 mks)
- (b) Use the first three terms of the expansion in (a) above to estimate the value of $\left(1 + \frac{1}{20}\right)^5$ (2 mks)
5. A particle moves in a straight line through a point P. Its velocity v m/s is given by $v = 2 - t$, where t is time in seconds, after passing P. The distance s of the particle from P when $t = 2$ is 5 metres. Find the expression for s in terms of t . (3 mks)
6. The cash price of a T.V set is Kshs 13, 800. A customer opts to buy the set on Hire purchase terms by paying a deposit of Kshs 2, 280. If simple interest of 20% p.a is charged on the balance and the customer is required to repay by 24 equal monthly installments, calculate the amount of each installment. (3 mks)
7. Find the equation of a straight line which is equidistant from the points (2,3) and (6, 1), expressing it in the form $ax + by = c$ where a , b and c are constants (4 mks)
8. A rectangular block has a square base whose side is exactly 8 cm. Its

height measured to the nearest millimeter is 3.1 cm

Find in cubic centimeters, the greatest possible error in calculating its volume.

(2 mks)

9. Water and milk are mixed such that the ratio of the volume of water to that of milk is 4: 1. Taking the density of water as 1 g/cm^3 and that of milk as 1.2 g/cm^3 , find the mass in grams of 2.5 litres of the mixture. (3 mks)
10. A carpenter wishes to make a ladder with 15 cross- pieces. The cross- pieces are to diminish uniformly in length from 67 cm at the bottom to 32 cm at the top. Calculate the length in cm, of the seventh cross- piece from the bottom (3 mks)
11. In the figure below AB is a diameter of the circle. Chord PQ intersects AB at N. A tangent to the circle at B meets PQ produced at R.

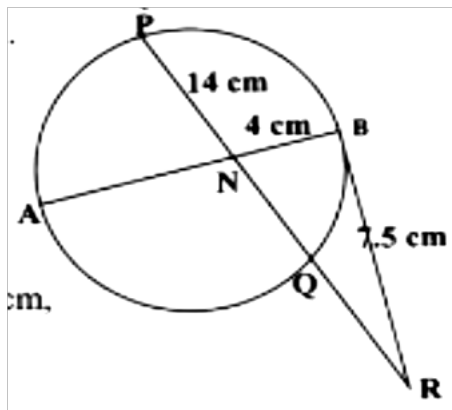

Given that $PN = 14 \text{ cm}$, $NB = 4 \text{ cm}$ and $BR = 7.5 \text{ cm}$, calculate the length of:

- (a) NR (1 mk)
- (b) AN (3 mks)
12. Vector q has a magnitude of 7 and is parallel to vector p . Given that $p = 3i - j + 1\frac{1}{2}k$, express vector q in terms of i, j , and k . (2 mks)
13. Two places A and B are on the same circle of latitude north of the equator. The longitude of A is 1180W and the longitude of B is 1330E . The shorter distance between A and B measured along the circle of latitude is 5422 nautical miles.
- Find, to the nearest degree, the latitude on which A and B lie (3 mks)
14. The figure below is a sketch of the graph of the quadratic function $y = k(x+1)(x-2)$

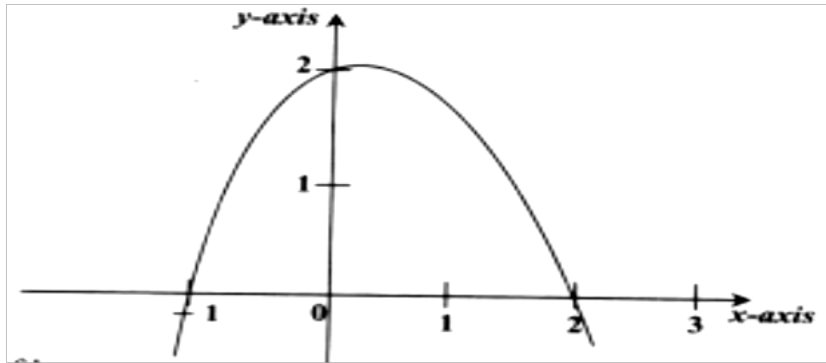

Find the value of k

15. Simplify $\frac{3}{\sqrt{5}-2} + \frac{1}{\sqrt{5}}$ leaving the answer in the form $a + b c$, where a , b and c are rational numbers (3 mks)
16. Find the radius and the coordinate of the centre of the circle whose equation is $2x^2 + 2y^2 - 3x + 2y + \frac{1}{2} = 0$ (4 mks)

SECTION 11 (50 MKS)

Answer any five questions in this section

17. A tank has two inlet taps P and Q and an outlet tap R. when empty, the tank can be filled by tap P alone in $4 \frac{1}{2}$ hours or by tap Q alone in 3 hours. When full, the tank can be emptied in 2 hours by tap R.
- (a) The tank is initially empty. Find how long it would take to fill up the tank
- (i) If tap R is closed and taps P and Q are opened at the same time (2 mks)
- (ii) If all the three taps are opened at the same time (2 mks)
- (b) The tank is initially empty and the three taps are opened as follows
P at 8.00 a.m Q at 8.45 a.m R at 9.00 a.m
- (i) Find the fraction of the tank that would be filled by 9.00 a.m (3 mks)
- (ii) Find the time the tank would be fully filled up (3 mks)
18. Given that y is inversely proportional to x^n and k as the constant of

proportionality;

(a) (i) Write down a formula connecting y , x , n and k (1 mk)

(ii) If $x = 2$ when $y = 12$ and $x = 4$ when $y = 3$, write down two expressions for k in terms of n .
Hence, find the value of n and k . (7 mks)

(b) Using the value of n obtained in (a) (ii) above, find y when $x = 5^{1/3}$ (2 mks)

19. (a) Given that $y = 8 \sin 2x - 6 \cos x$, complete the table below for the missing values of y , correct to 1 decimal place.

X	0°	15°	30°	45°	60°	75°	90°	105°	120°
$Y = 8 \sin 2x - 6 \cos x$	-6	-1.8		3.8	3.9	2.4	0		-3.9

(b) On the grid provided, below, draw the graph of $y = 8 \sin 2x - 6 \cos x$ for $0^\circ \leq x \leq 120^\circ$

Take the scale 2 cm for 150 on the x - axis
2 cm for 2 units on the y - axis (4 mks)

(c) Use the graph to estimate
(i) The maximum value of y (1 mks)
(ii) The value of x for which $4 \sin 2x - 3 \cos x = 1$ (3 mks)

20. The gradient function of a curve is given by the expression $2x + 1$. If the curve passes through the point $(-4, 6)$;

(a) Find:
(i) The equation of the curve (3 mks)
(ii) The values of x , at which the curve cuts the x - axis (3 mks)

(b) Determine the area enclosed by the curve and the x - axis (4 mks)

21. In this question use a ruler and a pair of compasses only

In the figure below, AB and PQ are straight lines

For marking schemes, Whatsapp/contact-0746711892

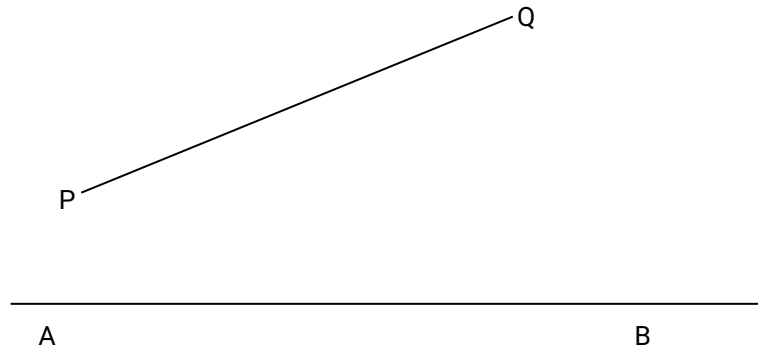

(a) Use the figure to:

(i) Find a point R on AB such that R is equidistant from P and Q (1 mk)

(ii) Complete a polygon PQRST with AB as its line of symmetry and hence measure the distance of R from TS. (5 mks)

(b) Shade the region within the polygon in which a variable point X must lie given that X satisfies the following conditions

I: X is nearer to PT than to PQ
II: RX is not more than 4.5 cm

III. $\angle PXT > 90^\circ$ (4 mks)

22. A company is considering installing two types of machines. A and B. The information about each type of machine is given in the table below.

Machine	Number of operators	Floor space	Daily profit
A	2	5m^2	Kshs 1,500
B	5	8m^2	Kshs 2,500

The company decided to install x machines of types A and y machines of type B

(a) Write down the inequalities that express the following conditions

I. The number of operators available is 40

II. The floor space available is 80m^2

III. The company is to install not less than 3 type of A machine

IV. The number of type B machines must be more than one third the number of type A machines

(b) On the grid provided, draw the inequalities in part (a) above and shade the unwanted region (4 mks)

- (c) Draw a search line and use it to determine the number of machines of each type that should be installed to maximize the daily profit. (2 mks)

23. The table below shows the values of the length X (in metres) of a pendulum and the corresponding values of the period T (in seconds) of its oscillations obtained in an experiment.

X (metres)	0.4	1.0	1.2	1.4	1.6
T (seconds)	1.25	2.01	2.19	2.37	2.53

- (a) Construct a table of values of $\log X$ and corresponding values of $\log T$,
correcting each value to 2 decimal places (2 mks)
- (b) Given that the relation between the values of $\log X$ and $\log T$ approximate to a linear law of the form $m \log X + \log a$ where a and b are constants

- (i) Use the axes on the grid provided to draw the line of best fit for the graph of $\log T$ against $\log X$. (2 mks)

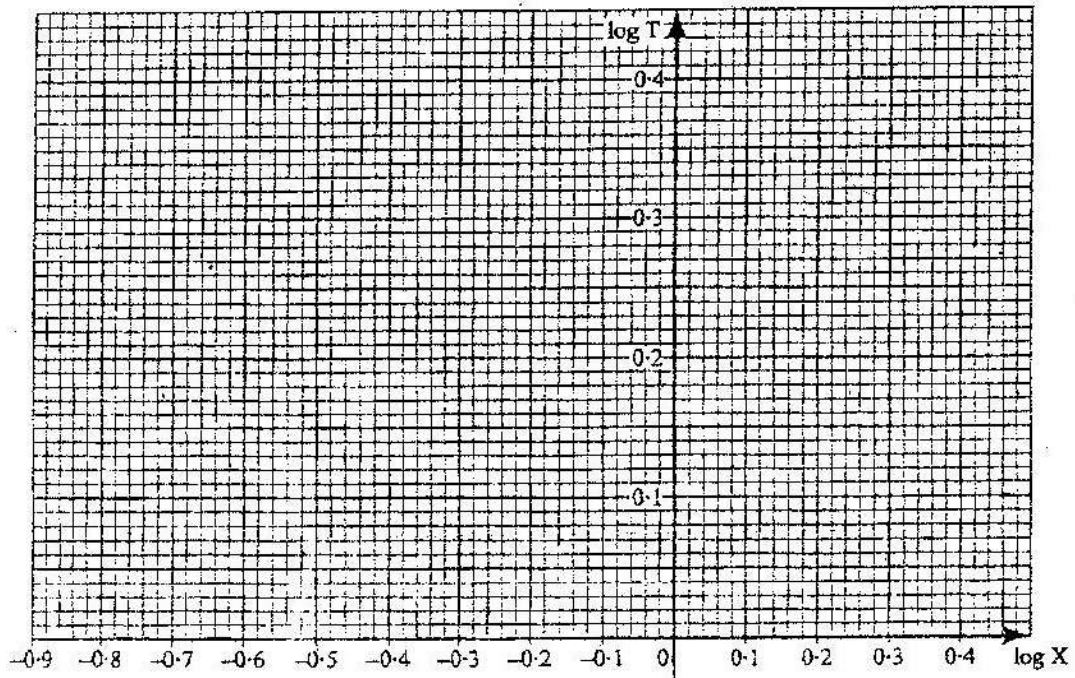

- (ii) Use the graph to estimate the values of a and b (3 mks)

- (b) Find, to decimal places the length of the pendulum whose period is 1 second (3 mks)

24. Two bags A and B contain identical balls except for the colours. Bag A contains 4 red balls and 2 yellow balls. Bag B contains 2 red balls and 3 yellow balls.

- (a) If a ball is drawn at random from each bag, find the probability that both balls are of the same colour. (4 mks)
- (b) If two balls are drawn at random from each bag, one at a time without replacement, find the probability that:
- (i) The two balls drawn from bag A or bag B are red (4 mks)
- (ii) All the four balls drawn are red (2 mks)

MATHEMATICS
K.C.S.E PAPER 121/ 2 2008
QUESTIONS

SECTION I (50 MKS)
Answer all the questions in this section

1. In this question, show all the steps in your calculations, giving the answer each stage.

Use logarithms correct to decimal places, to evaluate.
(3mks)

$$\frac{6.373 \log 4.948}{\sqrt{0.004636}}$$

2. Make h the subject of the formula

(3mks)

$$q = \frac{1+rh}{1-ht}$$

3. Line AB given below is one side of triangle ABC. Using a ruler and a pair of compasses only;

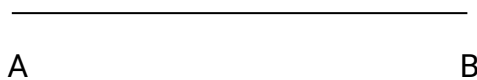

(i) Complete the triangle ABC such that $BC=5\text{cm}$ and $\angle ABC=45^\circ$

(ii) On the same diagram construct a circle touching sides AC, BA produced and BC produced. (2mks)

4. The position vectors of points A and B are $\begin{bmatrix} 3 \\ -1 \\ -4 \end{bmatrix}$ and $\begin{bmatrix} 8 \\ -6 \\ 6 \end{bmatrix}$ respectively.

A point P divides AB in the ratio 2:3. Find the position Vector of point P.

(3mks)

5 The top of a table is a regular hexagon. Each side of the hexagon measures 50.0 cm. Find the maximum percentage error in calculating the perimeter

of the top of the table.
(3mks)

6. A student at a certain college has a 60% chance of passing an examination at the first attempt. Each time a student fails and repeats the examination his chances of passing are increased by 15%

Calculate the probability that a student in the college passes an examination at the second or at the third attempt.

(3mks)

7. An aero plane flies at an average speed of 500 knots due East from a point P (53.40°E) to another point Q. It takes 2 $\frac{1}{4}$ hours to reach point Q.

Calculate:

- (i) The distance in nautical miles it traveled; (1mk)
(ii) The longitude of point Q to 2 decimal places (2mks)

8. a) Expand and simplify the expression
(2mks)

$$\left[10 + \frac{2}{x}\right]^5$$

- b) Use the expansion in (a) above to find the value of 145 (2mks)

9. In the figure below, angles BAC and ADC are equal. Angle ACD is a right angle. The ratio of the sides. AC: BC = 4: 3

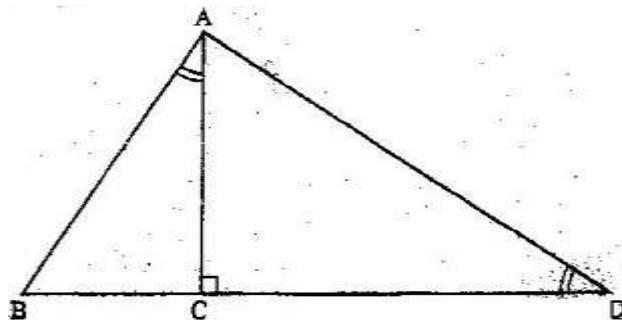

Given that the area of triangle ABC is 24 cm². Find the triangle ACD (3mks)

10. Points A(2,2) and B(4,3) are mapped onto A'(2,8) and B'(4,15) respectively by a transformation T. Find the matrix of T.

11. The equation of a circle is given by $4x^2 + 4y^2 - 8x + 20y - 7 = 0$.

Determine the coordinates of the centre of the circle.

(3mks)

12. Solve for y in the equation $\log_{10}(3y + 2) - 1 - \log_{10}(y - 4)$

(3mks)

13. Without using a calculator or mathematical tables, express $\frac{\sqrt{3}}{1 - \cos 30^\circ}$ in surd

form and simplify

(3mks)

14. The figure below represents a triangular prism. The faces ABCD, ADEF and CBFE are rectangles.

AB = 8cm, BC = 14cm, BF = 7cm and AF = 7cm.

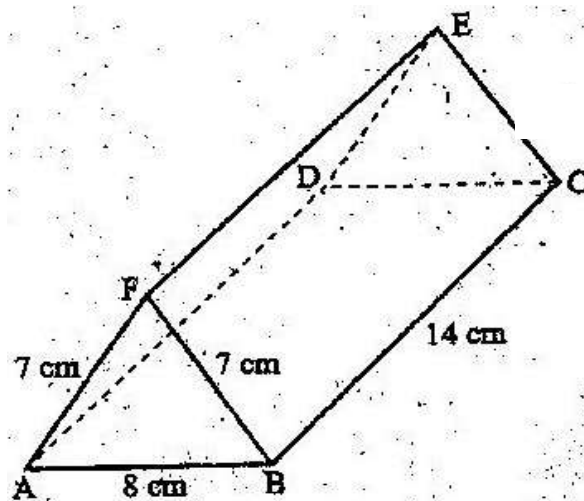

Calculate the angle between faces BCEF and ABCD.

(3mks)

15. A particle moves in a straight line from a fixed point. Its velocity $V \text{ m s}^{-1}$ after t seconds is given by $V = 9t^2 - 4t + 1$

Calculate the distance traveled by the particle during the third second.

(3mks)

16. Find in radians, the values of x in the interval $0 \leq x \leq 2\pi$ for which $2 \cos 2x = 1$. (Leave the answers in terms of π)

(4mks)

SECTION II (50MKS)

Answer any five questions in this section.

17. a) A trader deals in two types of rice; type A and with 50 bags of type B. If

For marking schemes, Whatsapp/contact-0746711892

he sells the mixture at a profit of 20%, calculate the selling price of one bag of the mixture. (4mks)

b) The trader now mixes type A with type B in the ratio $x : y$ respectively. If the cost of the mixture is Ksh 383.50 per bag, find the ratio $x : y$. (4mks)

c) The trader mixes one bag of the mixture in part (a) with one bag of the mixture in part

(b). Calculate the ratio of type A rice to type B rice in this mixture. (2mks)

18. Three variables p , q and r are such that p varies directly as q and inversely as the square of r .

(a) When $p=9$, $q=12$ and $r = 2$. Find p when $q= 15$ and $r =5$ (4mks)

(b) Express q in terms of p and r . (1mks)

(c) If p is increased by 10% and r is decreased by 10%, find;

(i) A simplified expression for the change in q in terms of p and r (3mks)

(ii) The percentage change in q . (2mks)

19. a) complete the table below, giving the values correct to 2 decimal places.

x°	0	30	60	90	120	150	180	210	240	270	300	330	360
$\sin 2x$	0		0.87		-0.87		0	0.87	0.87				0
$3\cos x - 2$	1	0.60		-2	-3.5			-4.60			-0.5		1

b) On the grid provided, draw the graphs of $y=\sin 2x$ and $y=3\cos x - 2$ for $0^\circ \leq x \leq 360^\circ$ on the same axes. Use a scale of 1 cm to represent 30° on the x-axis and 2cm to represent 1 unit on the y-axis.

c) Use the graph in (b) above to solve the equation $3 \cos x - \sin 2x = 2$. (2mks)

d) State the amplitude of $y = 3\cos x - 2$. (1mk)

20. In the figure below DA is a diameter of the circle ABCD centre O, radius 10cm. TCS is a tangent to the circle at C, $AB=BC$ and angle $DAC= 38^\circ$



- a) Find the size of the angle;
- i. ACS; (2mks)
 - ii. BCA (2mks)
- b) Calculate the length of:
- i. AC (2mks)
 - ii. AB (4mks)

21. Two policemen were together at a road junction. Each had a walkie talkie. The maximum distance at which one could communicate with the other was 2.5 km. One of the policemen walked due East at 3.2 km/h while the other walked due North at 2.4 km/h the policeman who headed East traveled for x km while the one who headed North traveled for y km before they were unable to communicate.

- (a) Draw a sketch to represent the relative positions of the policemen. (1mk)
- (b) (i) From the information above form two simultaneous equations in x and y . (2mks)
- (ii) Find the values of x and y . (5mks)
- (iii) Calculate the time taken before the policemen were unable to communicate. (2mks)

22. The table below shows the distribution of marks scored by 60 pupils in a test.

Marks	11-20	21-30	31-40	41-50	51-60	61-70	71-80	81-90
Frequency	2	5	6	10	14	11	9	3

- a) On the grid provided, draw an ogive that represents the above information (4mks)
- b) Use the graph to estimate the interquartile range of this information. (3mks)

23. Halima deposited Ksh. 109375 in a financial institution which paid simple interest at the rate of 8% p.a. At the end of 2 years, she withdrew all the money. She then invested the money in share. The value of the shares depreciated at 4% p.a. during the first year of investment. In the next 3 years, the value of the shares appreciated at the rate of 6% every four months

- a) Calculate the amount Halima invested in shares. (3mks)
- b) Calculate the value of Halima's shares.
- (i) At the end of the first year; (2mks)
- (ii) At the end of the fourth year, to the nearest shilling. (3mks)
- c) Calculate Halimas gain from the share as a percentage. (2mks)

24. The table below shows values of x and some values of y for the curve $y = x^3 + 3x^2 - 4x - 12$ in the range $-4 \leq x \leq 2$.

- a) Complete the table by filling in the missing values of y.

X	-4	-3.5	-3	-2.5	-2	-1.5	-1	-0.5	0	0.5	1	1.5	2.0
Y		-4.1		-1.1			-9.4	-9.0		-13.1		-7.9	

- b) On the grid provided, draw the graph $y = x^3 + 3x^2 - 4x - 12$ for $-4 \leq x \leq 2$. Use the scale. Horizontal axis 2cm for 1 unit and vertical axis 2cm for 5 units.

(3mks)

- c) By drawing a suitable straight line on the same grid as the curve, solve the equation $x^3+3x^2-5x-6=0$ (5mks)

MATHEMATICS
K.C.S.E PAPER 121/ 2 2009
QUESTIONS

SECTION (50 MARKS)

Answer all the questions in this section

1. A farmer feed every two cows on 480 Kg of hay for four days. The farmer has 20 160Kg of hay which is just enough to feed his cows for 6 weeks. Find the number of cows in the farm. (3 mks)
2. Find a quadratic equation whose roots are $1.5 + \sqrt{2}$ and $1.5 - \sqrt{2}$, expressing it in the form $ax^2 + bx + c = 0$, where a, b and c are integers (3 mks)
3. The mass of a wire m grams (g) is partly a constant and partly varies as the square of its thickness t mm. when $t = 2$ mm, $m = 40$ g and when $t = 3$ mm, $m = 65$ g
Determine the value of m when $t = 4$ mm. (4 mks)
4. In the figure below, O is the centre of the circle and radius ON is perpendicular to the line TS at N.

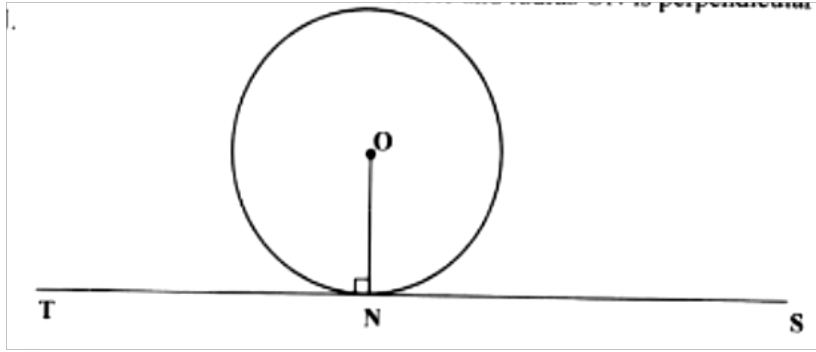

Using a ruler and a pair of compasses only, construct a triangle ABC to inscribe the circle, given that angle ABC = 60° , BC = 12 cm and points B and C are on the line TS (4 mks)

5. a solution was gently heated, its temperature readings taken at intervals of 1 minute and recorded as shown in the table below .

Time(Min)	0	1	2	3	4	5
Temperature ($^\circ\text{C}$)	4	5.2	8.4	14.3	16.3	17.5

- a) Draw the time-temperature graph on the grid provided (2 mks)
 b) Use the graph to find the average rate of change in temperature
 Between $t = 1.8$ and $t = 3.4$ (2 mks)

6. Vector $\text{OA} = \begin{bmatrix} 2 \\ 1 \end{bmatrix}$ and $\text{OB} = \begin{bmatrix} 6 \\ -3 \end{bmatrix}$ c is on OB such that $\text{CB} = 2 \text{OC}$ and

Point D is on AB such that $\text{AD} = 3 \text{DB}$.

Express CD as a column vector. (3mks)

7. In a certain commercial bank, customer may withdraw cash through one of the two tellers at the counter. On average, one teller takes 3 minutes while the other teller takes 5 minutes to serve a customer. If the two tellers start to serve the customers at the same time, find the shortest time it takes to serve 200 customers. (3 mks)

8. a) Expand and simplify the binomial expression $(2 - x)^7$ in ascending powers of x. (2mks)
 b) Use the expansion up to the fourth term to evaluate $(1.97)^7$

correct
to 4 decimal places
mks)

(2

9. The area of triangle FGH is 21cm^2 . The triangle FGH is transformed using the matrix $\begin{bmatrix} 4 & 5 \\ 1 & 2 \end{bmatrix}$

Calculate the area of the image of triangle FGH (2 mks)

10. Simplify $\frac{\sqrt{3}}{\sqrt{3}-\sqrt{2}}$ (2mks)

11. A circle whose equation is $(x - 1)^2 + (y - k)^2 = 10$ passes through the point (2,5). Find the coordinates of the two possible centres of the circle. (3 mks)

12. On a certain day, the probability that it rains is $\frac{1}{7}$. When it rains the probability that Omondi carries an umbrella is $\frac{2}{3}$. When it does not rain the probability that Omondi carries an umbrella is $\frac{1}{6}$. Find the Probability that Omondi carried an umbrella that day (2 mks)

13. Point P (40°S , 45°E) and point Q (40°S , 60°W) are on the surface of the Earth. Calculate the shortest distance along a circle of latitude between the two points. (3 mks)

14. Solve $4 - 4 \cos^2 a \sin^2 a - 1$ for $0^\circ \leq a \leq 360^\circ$ (4 mks)

15. In the figure below, AT is a tangent to the circle at A $TB = 480$, $BC = 5$ cm and $CT = 4$ cm.

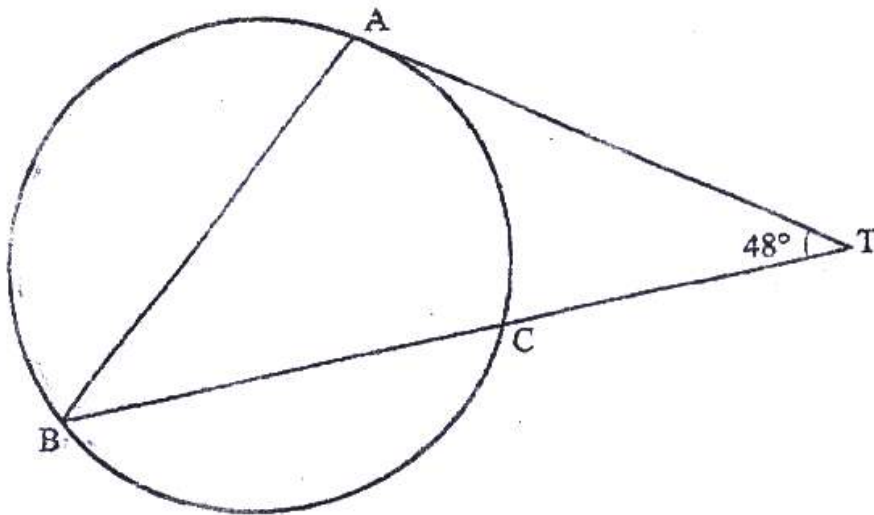

Calculate the length AT.
mks)

(2

16. A particle moves in a straight line with a velocity $V \text{ms}^{-1}$. Its velocity after t seconds is given by $V = 3t^2 - 6t - 9$.

The figure below is a sketch of the velocity-time graph of the particle

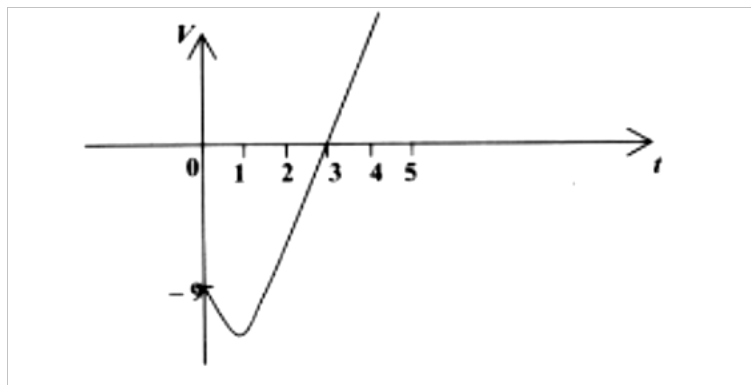

Calculate the distance the particle moves between $t = 1$ and $t = 4$
mks)

(4

SECTION II (50 MKS)

Answer only five questions in this section in the spaces provided

17. A water vendor has a tank of capacity 18900 litres. The tank is being filled with water from two pipe A and B which are closed immediately when the tank is full. Water flows at the rate of
- a) If the tank is empty and the two pipes are opened at the same time, calculate the time it takes to fill the tank. (3 mks)
- b) On a certain day the vendor opened the two pipes A and B to fill the empty tank. After 25 minutes he opened the outlet to supply water to his customers at an average rate of 20 Liters per minute
- i) Calculate the time it took to fill the tank on that day. (3 mks)
- ii) The vendor supplied a total of 542 jerricans, each containing 25 litres of water, on the day. If the water that remained in the tank was 6 300 litres, calculate, in litres, the amount of water that was wasted. (3 mks)
18. At the beginning of the year 1998, Kanyingi bought two houses, one in Thika and the other one Nairobi, each at Ksh 1 240 000. The value of the house in Thika appreciated at the rate of 12% p.a
- a) Calculate the value of the house in thirika after 9 years, to the nearest shilling. (2 mks)
- b) After n years, the value of the house in Thika was Kshs 2 741 245 while the value of the house in Nairobi was Kshs 2 917 231. (4 mks)
- i) Find n
- ii) Find the annual rate of appreciation of the house in Nairobi. (4 mks)
19. The table below shows the number of goals scored in handball matches during a tournament.

Number of goal	0-9	10-19	20-29	30-39	40-49

Number of matches	2	14	24	12	8
-------------------	---	----	----	----	---

Draw a cumulative frequency curve on the grid provided (5 mks)

b) Using the curve drawn in (a) above determine;

i) The median; (1 mk)

ii) The number of matches in which goals scored were not more than 37; (1 mk)

iii) The inter-quartile range (3 mks)

20. Triangle PQR shown on the grid has vertices p(5,5), Q(10, 10) and R(10,15)

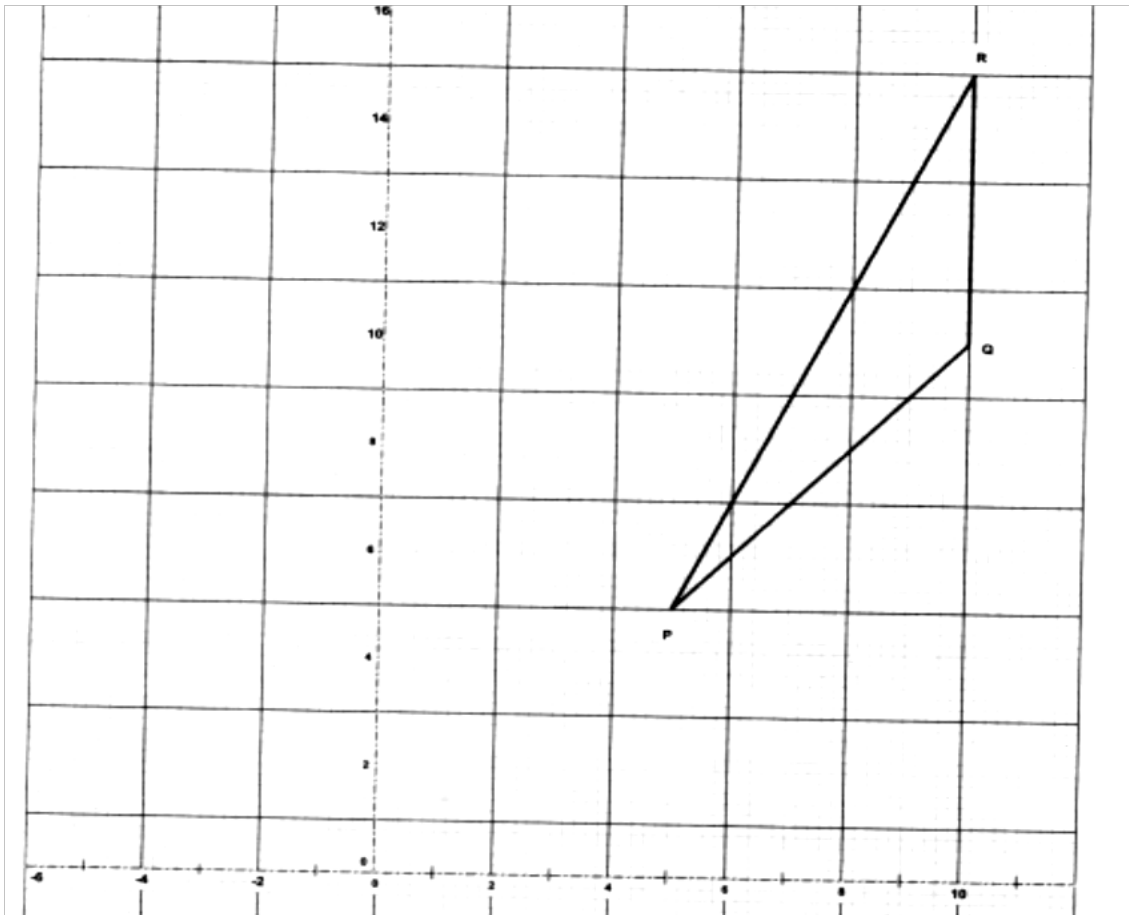

a) Find the coordinates of the points p', Q' and R' and the images of P, Q and R respectively under transformation M whose matrix is (2 mks)

$$\begin{bmatrix} -0.6 & 0.8 \\ 0.8 & 0.6 \end{bmatrix}$$

- b) Given that M is a reflection;
- i) draw triangle P'Q'R' and the mirror line of the reflection; (1 mk)
 - ii) Determine the equation of the mirror line of the reflection (1 mk)
- c) Triangle P''Q''R'' is the image of triangle P'Q'R' under reflection N
is a reflection in the y-axis.
- i) draw triangle P''Q''R''
 - ii) Determine a 2 x2 matrix equivalent to the transformation NM (2 mks)
 - iii) Describe fully a single transformation that maps triangle PQR onto triangle P''Q''R'' (2 mks)

21. The table below shows income tax rates.

Monthly income in Kenya shillings (Kshs)	Tax rate percentage (%) In each shilling
Up to 9 680	10
From 9681 to 18 800	15
From 18 801 to 27 920	20
From 27 921 to 37 040	25
From 37 041 and above	30

In certain year, Robi's monthly taxable earnings amounted to Kshs. 24 200.

- a) Calculate the tax charged on Robi's monthly earnings. (4 mks)
- b) Robi was entitled to the following tax reliefs:
 - I: monthly personal relief of Ksh 1,056;

II: Monthly insurance relief at the rate of 15% of the premium paid.

Calculate the tax paid by Robi each month, if she paid a monthly premium of Kshs 2 400 towards her life insurance policy. (2 mks)

- C) During a certain month, Robi received additional earnings which were taxed at 20% in each shilling. Given that she paid 36.3% more tax that month, calculate the percentage increase in her earnings. (4 mks)

22. The figure below shows a right pyramid mounted onto a cuboid.

$AB=BC= 15\sqrt{2}$ cm, $CG =$ and $VG = 17\sqrt{2}$ cm.

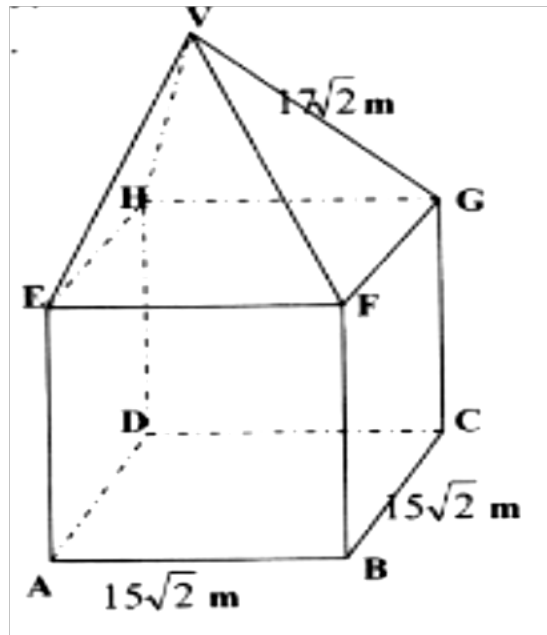

Calculate:

- The length of AC;
 - The angle between the line AG and the plane ABCD;
 - The vertical height of point V from the plane ABCD;
 - The angle between the planes EFV and ABCD.
23. a) The first term of an Arithmetic Progression (AP) is 2. The sum of the first 8 terms of the AP is 156
- Find the common difference of the AP. (2 mks)
 - Given that the sum of the first n terms of the AP is 416, find n. (2mks)
- b) The 3rd, 5th and 8th terms of another AP form the first three terms of a Geometric Progression (GP)

If the common difference of the AP is 3,
find:

- i) The first term of the GP; (4 mks)
- ii) The sum of the first 9 terms of the GP, to 4 significant figures.
(2mks)

24. Amina carried out an experiment to determine the average volume of a ball bearing. He started by submerging three ball bearings in water contained in a measuring cylinder. She then added one ball a time into the cylinder until the balls were nine.. The corresponding readings were recorded as shown in the table below

Number of ball bearings(x	3	4	5	6	7	8	9
Measuring	98.0	105.0	123.0	130.5	145.6	156.9	170.0

- a) i) On the grid provided, Plot (x, y) where x is the number of ball bearings and y is the corresponding measuring cylinder, reading. (3 mks)
- ii) Use the plotted points to draw the line of best fit (1 mk)
- b) Use the plotted points to draw the line of best fit. (1 mk)
- i) The average volume of a ball bearing; (2 mks)
- ii) The equation of the line. (2 mks)
- c) Using the equation of line in b(ii) above, determine the volume of the water in the cylinder. (2 mks)

MATHEMATICS
K.C.S.E PAPER 121/ 2 2010
QUESTIONS

SECTION I (50 marks)

Answer all the questions in this section

1. The length and width of a rectangle measured to the nearest millimeter are 7.5cm and 5.2cm respectively. Find, to four significant figures, the percentage error in the area of the rectangle. (3 mks)

2. Simplify

$$\frac{4}{\sqrt{5+\sqrt{2}}} - \frac{3}{\sqrt{5-\sqrt{2}}} \quad (3 \text{ mks})$$

3. In the figure below, O is the center of the circle which passes through the point T, C and D. line TC is parallel to OD and line ATB is a tangent to the circle at T. angle DOC = 360

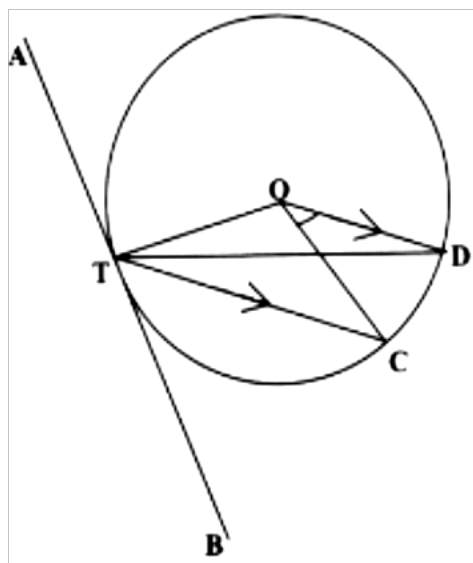

Calculate the size of angle CTB (3 mks)

4. A tea dealer mixes two brands of tea, x and y, to obtain 35 kg of the mixture worth Ksh.65 per kg. If brand x is valued at Ksh.68 per kg and brand y at Ksh. 53 per kg, calculate the ratio, in its simplest form, in which the brands x and y are mixed. (3 mks)
5. The length of flower garden is 2 m less than twice its width. The area of the garden is 60m².

Calculate its length.

(3 mks)

6. Five people can build 3 huts in 21 days. Find the number of people, working at the same rate that will build 6 similar huts in 15 days.

(2 mks)

7. When Ksh. 40 000 was invested in a certain bank for 5 years it earned a simple interest of Ksh.3800. Find the amount that must have been invested in the same bank at the same bank at the same rate for $7\frac{1}{2}$ year to earn a simple interest of Ksh.3 420

(3 mks)

8. The heights, in centimeters, of 100 tree seedlings are shown in the table below.

Number of seedlings	9	16	19	26	20	10
Height (cm)	10-19	20-29	30-39	40-49	50-59	60-69

Find the quartile deviation of the heights.
mks)

(4

9. A bag contains 2 white balls and 3 black balls. A second bag contains 3 white balls and 2 black balls. The balls are identical except for the colours.

Two balls are drawn at random, one after the other from the first bag and placed in the second bag. Calculate the probability that the 2 balls are both white.
mks)

(2

10. The point O, A and B have the coordinates (0,0), (4,0) and (3,2) respectively.

Under shear represented by the matrix $\begin{pmatrix} 1 & k \\ 0 & 1 \end{pmatrix}$, triangle OAB maps onto triangle OAB'

- a) Determine in terms of k , the x coordinates of point B'

(2 mks)

- b) If OAB' is a right angled triangle in which angle OB' A is acute, find two possible values of k .

(2 mks)

11. A particle starts from O and moves in a straight line so that its velocity $V \text{ ms}^{-1}$ after time t seconds is given by $V = 3t - t^2$. The distance of the particle from O at time t seconds is s metres.

- a) Express s in terms of t and c where c is a constant.

(1

mk)

b) Calculate the time taken before the particle returns to O. (3 mks)

12. a) Expand and simplify $(2 - x)^5$ (2 mks)

b) Use the first 4 terms of the expression in part (a) above to find the approximate value of $(1.8)^5$ to 2 decimal places.

13. a) Using line AB given below, construct the locus of a point P such that $\angle APB = 90^\circ$. (1 mk)



b) On the same diagram locate **two** possible positions of point C such that point C is on the locus of P and is equidistant from A and B. (2 mks)

14. Make x the subject of the equation:

$$3y = y + \frac{p}{q + \frac{1}{x}}$$

(3 mks)

15. Find the value of x given that

$$\log(15 - 5x) - 1 = \log(3x - 2)$$

(3 mks)

16. The circle shown below cuts the x-axis at $(-2,0)$ and $(4,0)$. It also cuts the y-axis at $(0,2)$ and $(0,-4)$.

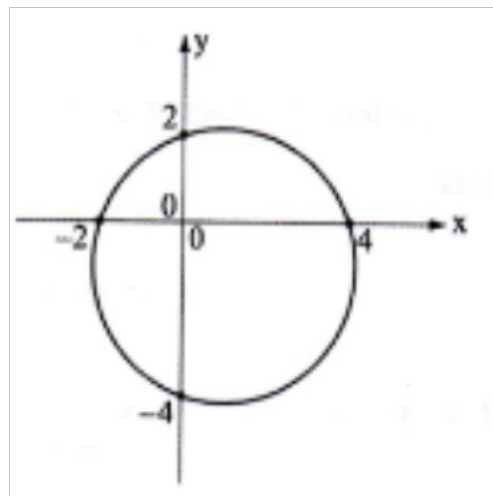

Determine the:

a) i) Coordinates of the centre; (1 mk)

For marking schemes, Whatsapp/contact-0746711892

ii) radius of the circle.
mk)

(1

b) Equation of the circle in the form $x^2 + y^2 + ax + by = c$ where a, b and c are constants.

(2 mks)

SECTION II (50 marks)
Answer all five questions in this section

17. (a) Complete the table below, giving the value correct to 2 decimal places. (2 mks)

X°	0°	20°	40°	60°	80°	100°	120°	140°	160°	180°
$\text{Cos } X^\circ$	1.00	0.94	0.77	0.50		-0.17		-0.77		-1.00
$\text{Sin } x^\circ - \text{Cos } x^\circ$	-1.00	-0.60		0.37	0.81		1.37		1.28	1.00

- b) On the grid provided and using the same axes draw the graphs of $y = \text{Cos } x^\circ$ and $y = \text{sin } x^\circ - \text{Cos } x^\circ$ for $0^\circ \leq x \leq 180^\circ$. Using the scale; 1 cm for 200 on the x-axis and 4cm for 1 unit on the y-axis. (5 mks)
- c) Using the graph in part (b);
- Solve the equation $\text{sin } x^\circ - \text{cos } x^\circ = 1.2$; (1 mk)
 - Solve the equation $\text{cos } x^\circ = \frac{1}{2} \text{sin } x^\circ$; (1 mk)
 - Determine the value of $\text{cos } x^\circ$ in part (c) (ii) above. (1 mk)

18. In the figure below OJKL is a parallelogram in which $OJ = 3p$ and $OL = 2r$



- If A is a point on LK such that $LA = \frac{1}{2} AK$ and point B divide the line JK externally in the ratio 3:1, express \mathbf{OB} and \mathbf{AJ} in terms of \mathbf{p} and \mathbf{r} . (2 mks)
- Line OB interests AJ at X such that $\mathbf{OX} = m\mathbf{OB}$ and $\mathbf{AX} = n\mathbf{AJ}$.
 - Express OX in terms of p, r and m. (1 mk)
 - Express OX in terms of p, r and n (1 mk)

iii) Determine the value of m and n and hence the ratio in which point x divides line AJ . (6 mks)

19. The position of three points A , B and C are $(34^{\circ}\text{N}, 16^{\circ}\text{W})$, $(34^{\circ}\text{N}, 24^{\circ}\text{E})$ and $(26^{\circ}\text{S}, 16^{\circ}\text{W})$ respectively.

a) Find the distance in nautical miles between:

i) Port A and B to the nearest nautical miles;
(3mks)

ii) Ports A and C . (2 mks)

b) A ship left port A on Monday at 1330h and sailed to Port B at 40 knots.

Calculate:

i) The local time at port B when the ship left port A ;
(2 mks)

ii) The day and the time the ship arrived at port B
(3 mks)

20. A carpenter takes 4 hours to make a stool and 6 hours to make chair. It takes the carpenter and at least 144 hours to make x stools and y chairs. The labour cost should not exceed Ksh.4800. the carpenter must make a least 16 stools and more than 10 chairs.

a) Write down inequalities to represent the above information. (3 mks)

b) Draw the inequality in (a) above on a grid.
(4mks)

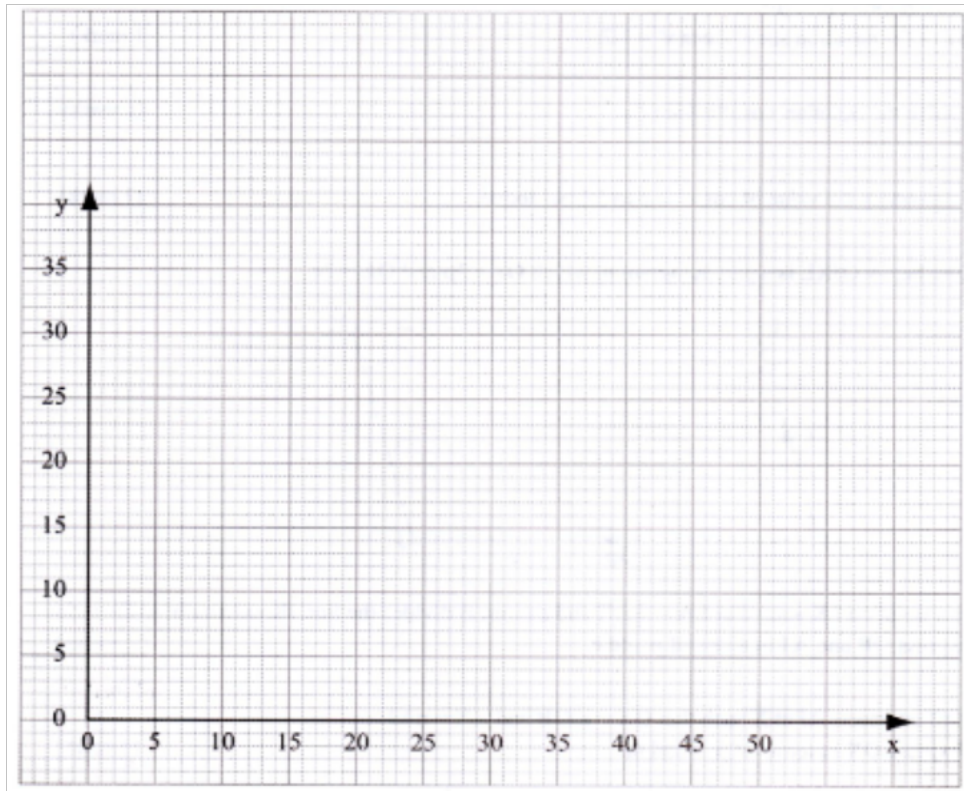

- c) The carpenter makes a profit of Ksh 40 on a stool and Ksh 100 on a chair.
Use
the graph to determine the maximum profit the carpenter can make.
(3 mks)

21. A hall can accommodate 600 chairs arranged in rows. Each row has the same number of chairs. The chairs are rearranged such that the number of row is increased by 5 but the number of chairs per row is decreased by 6.

- a) Find the original number of rows of chairs in the hall. (6 mks)
- b) After the re-arrangement 450 people were seated in the hall leaving the same number of empty chairs in each row. Calculate the number of empty chairs per row. (4 mks)

22. The first term of an Arithmetic Progression (A.P.) with six terms is p and its common difference is c . Another A.P. with five terms has also its first term as p and a common difference of d . the last terms of the two Arithmetic Progressions are equal.

- a) Express d in terms of c . (3 mks)

- b) Given that the 4th term of the second A.P. exceeds the 4th term of the first one by $1\frac{1}{2}$, find the value of c and d. (3 mks)
- c) Calculate the value of p if the sum of the terms of the first A.P. is 10 more than the terms of the second A.P. (4mks)

23. In a uniform accelerated motion the distance

- a) Express in terms of (3 mks)
- b) Find:
- i) The distance travelled in 5 seconds; (2 mks)
- ii) The time taken to travel a distance of 560 metres. (3 mks)

24. In the figure below, P, Q, R and S are points on the circle. Line USTV is a tangent to the circle at S, $\angle RST = 50^\circ$ and $\angle RTV = 150^\circ$. PRT and USTV are straight lines.

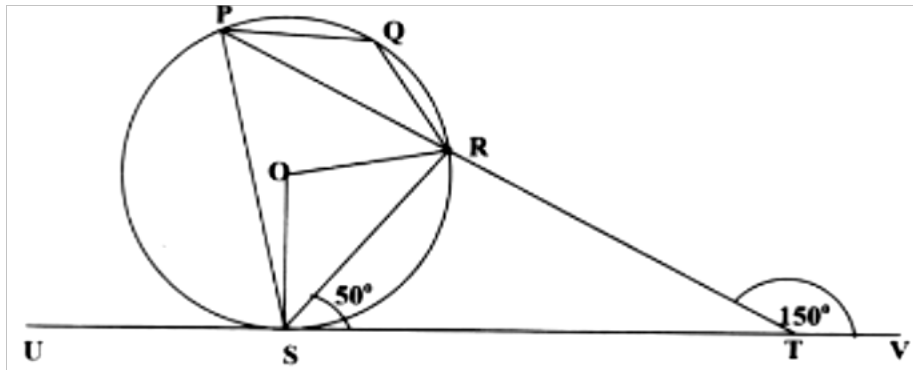

- a) Calculate the size of:
- i) $\angle ORS$; (2 mks)
 - ii) $\angle USP$; (1mk)
 - iii) $\angle PQR$ (2 mks)
- b) Given that $RT = 7$ cm and $ST = 9$ calculate to 3 significant figures:
- i) The length of line PR ; (2 mks)
 - ii) The radius of the circle. (3 mks)

MATHEMATICS
K.C.S.E PAPER 121/ 2 2011
QUESTIONS

SECTION I (50 mks)

Answer all the questions in this section

- 1 Use logarithms, correct to 4 decimal places, to evaluate

$$\sqrt[3]{\frac{83.46 \times 0.0054}{1.56^2}} \quad (4)$$

mks)

2. Three grades A, B, and C of rice were mixed in the ratio 3:4:5. The cost per kg of each of the grades A, B and C were Ksh 120, Ksh 90 and Ksh 60 respectively.

Calculate:

- (a) The cost of one kg of the mixture; (2 mks)

- (b) The selling price of 5 kg of the mixture given that the mixture was sold at 8% profit, (2 mks)

3. Make s the subject of the formula.

$$W = \sqrt[3]{\frac{s+t}{s}} \quad (3 \text{ mks})$$

4. (a) Solve the inequalities $2x - 5 > -11$ and $3 + 2x \leq 13$, giving the answer as a combined inequality.

(3 mks)

- (b) List the integral values of x that satisfy the combined inequality in (a) (1 mk)

above.

5. In the figure below, ABCD is a cyclic quadrilateral. Point O is the centre of the circle. Angle ABO = 30° and angle ADO = 40°.

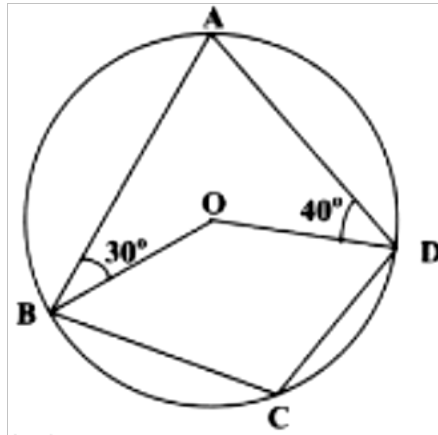

Calculate the size of angle BCD.

(2 mks)

6. The ages in years of five boys are 7, 8, 9, 10 and 11 while those of five girls are 4, 5, 6, 7 and 8. A boy and a girl are picked at random and the sum of their ages is recorded.
- (a) Draw a probability space to show all the possible outcomes. (1 mk)
- (b) Find the probability that the sum of their ages is at least 17 years. (1 mk)
7. The vertices of a triangle are A(1,2), B(3,5) and C(4,1). The coordinates of C' the image of C under a translation vector T, are (6-2).
- (a) Determine the translation vector T. (1 mk)
- (b) Find the coordinates of A' and B1 under translation vector T. (2 mks)
8. Write $\sin 45^\circ$ in the form $\frac{1}{\sqrt{a}}$ where a is a positive integer. Hence simplify $\frac{\sqrt{8}}{1+\sin 45^\circ}$ leaving the answer in surd form. (3 mks)
9. The radius of a spherical ball is measured as 7 cm, correct to the nearest centimeter. Determine, to 2 decimal places, the percentage error in calculating the surface area of the ball. (4 mks)
- For marking schemes, Whatsapp/contact-0746711892

10. (a) In the figure below, lines NA and NB represent tangents to a circle at points A and B.

Use a pair of compasses and ruler only to construct the circle. (2

mks)

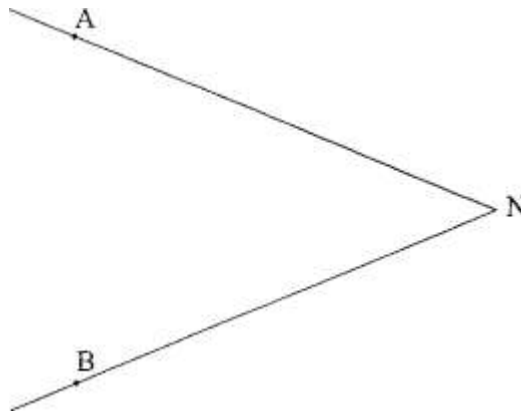

- (b) Measure the radius of the circle. (1

mk)

- 11 Expand and simplify the expression. (3

mks)

$$\left(a + \frac{1}{2}\right)^4 + \left(a - \frac{1}{2}\right)^4$$

12. The figure below represents a scale drawing of a rectangular piece of land, RSTU. RS = 9 cm and ST = 7 cm.

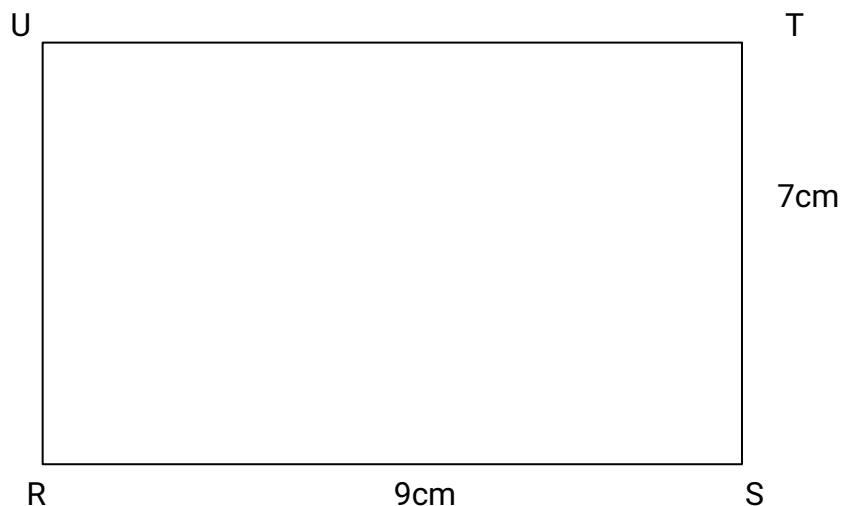

An electric post P, is to be erected inside the piece of land. On the scale drawing, shade the possible region in which P would lie such that $PU > PT$ and $PS \leq 7$ cm (3 mks)

13. Vector $\mathbf{OP} = 6\mathbf{i} - \mathbf{j}$ and $\mathbf{OQ} = -2\mathbf{i} - 5\mathbf{j}$. A point N divides PQ internally in the ratio 3:1.

Find \mathbf{PN} in terms of \mathbf{i} and \mathbf{j} . (3mks)

14. A point M (60°N , 18°E) is on the surface of the earth. Another point N is situated at a distance of 630 nautical miles east of M.

Find:

(a) the longitude difference between M and N; (2 mks)

(b) The position of N. (1 mk)

15. The equation of a circle centre (a, b) is $x^2 - y^2 - 6x - 10y + 30 = 0$. Find the values of a and b. (3 mks)

16. The table below shows values of x and y for the function $y = 2 \sin 3x^\circ$ in the range $0^\circ \leq x \leq 150^\circ$

x°	0	15	30	45	60	75	90	105	120	135	150
y	0	1.4	2	1.4	0	-1.4	-2	-1.4	0	1.4	2

(a) On the grid provided, draw the graph of $y = 2 \sin 3x$. (2 mks)

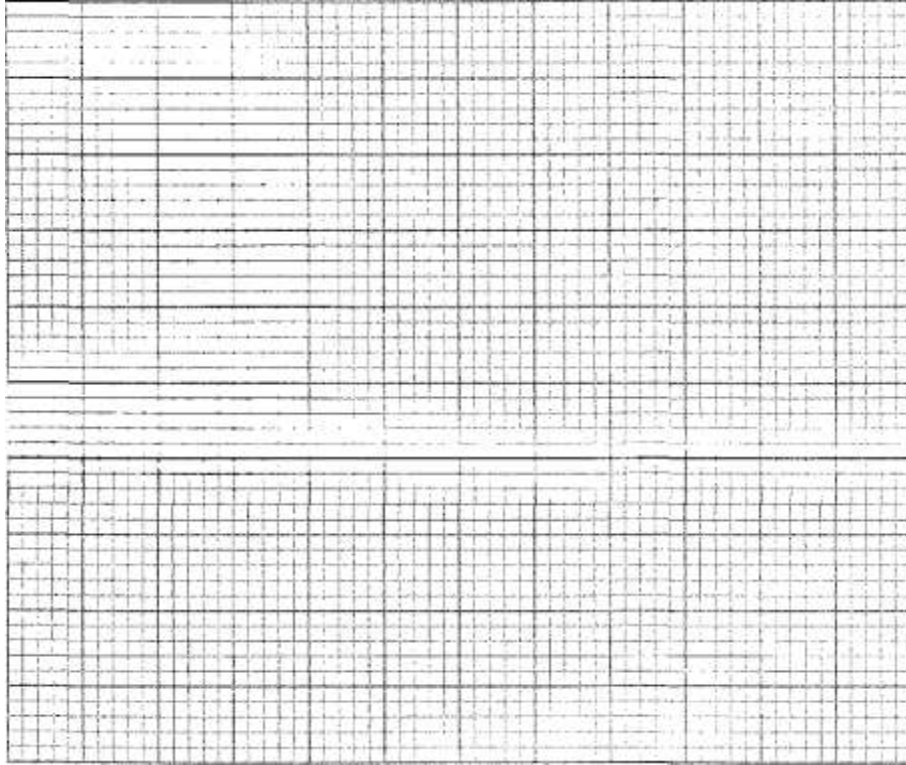

- mk) (b) From the graph determine the period. (1)

SECTION II (50 mks)

Answer only five questions in this section

- 17 The cash price of a laptop was Ksh 60 000. On hire purchase terms, a deposit of Ksh 7 500 was paid followed by 11 monthly installments of Ksh 6 000 each.
- (a) Calculate:
- (i) the cost of a laptop on hire purchase terms; (2 mks)
 - (ii) the percentage increase of hire purchase price compared to the cash price. (2 mks)
- (b) An institution was offered a 5% discount when purchasing 25 such laptops on cash terms. Calculate the amount of money paid by the institution. (2 mks)
- (c) Two other institutions, X and Y, bought 25 such laptops each. Institution X bought the laptops on hire purchase terms. Institution Y bought the laptops on cash terms with no discount by securing a loan from a bank. The bank charged 12% p.a. compound interest for two years.

Calculate how much more money institution Y paid than institution X. (4 mks)

18. The first, fifth and seventh terms of an Arithmetic Progression (AP) correspond to the first three consecutive terms of a decreasing Geometric Progression (G.P). The first term of each progression is 64, the common difference of the AP is d and the common ratio of the G.P is r .
- (a) (i) Write two equations involving d and r . (2 mks)
- (ii) Find the values of d and r . (4 mks)
- (b) Find the sum of the first 10 terms of:
- (i) The Arithmetic Progression (A.P); (2 mks)
- (ii) The Geometric Progression (G.P). (2 mks)

19 The vertices of a rectangle are A(-1,-1), B(-4,-1),C(-4,-3) and D(-1,-3).

- (a) On the grid provided, draw the rectangle and its image A' B' C' D' under a transformation whose matrix is $\begin{pmatrix} -2 & 0 \\ 0 & -2 \end{pmatrix}$ (4 mks)

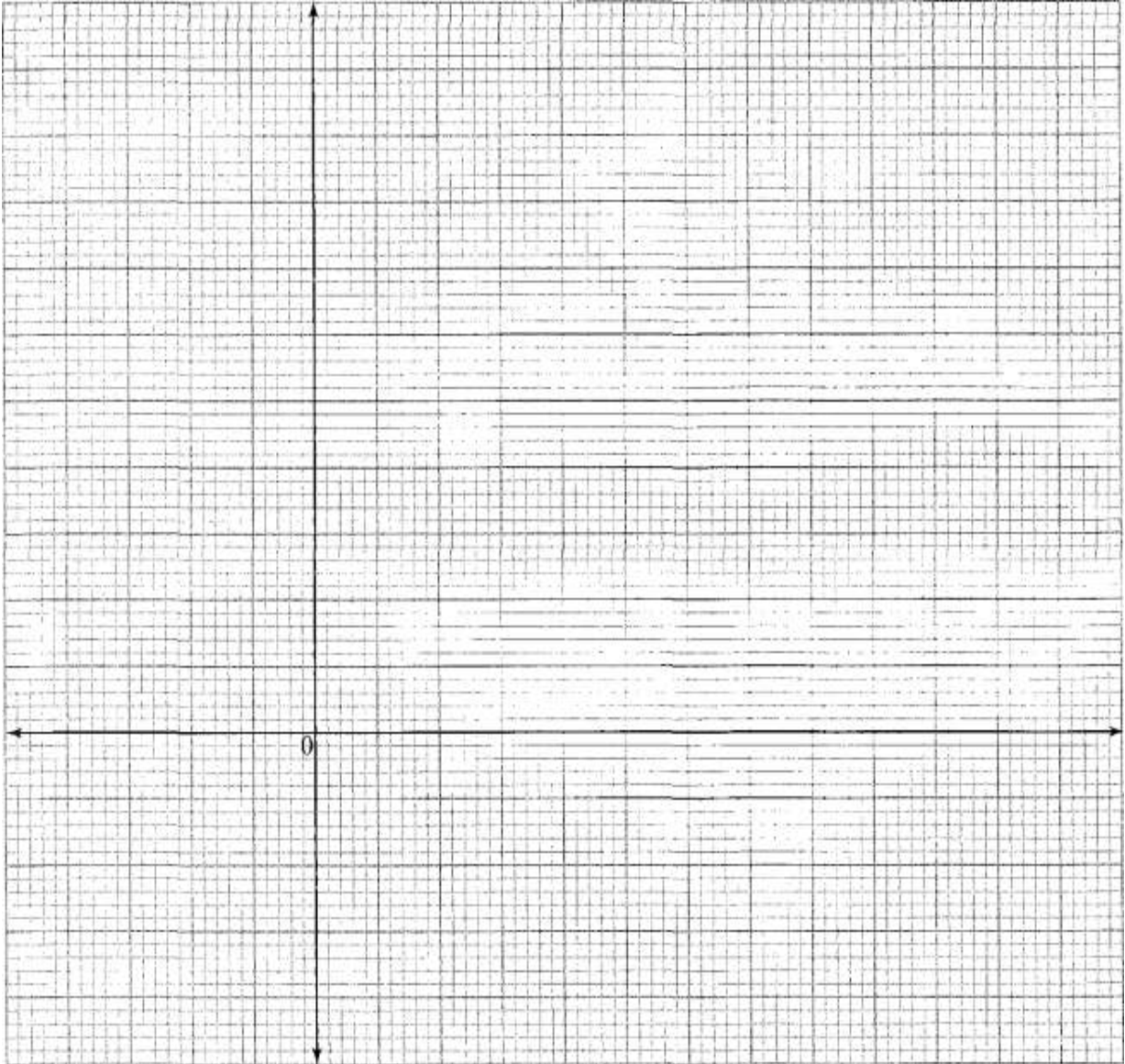

- b) A'' B'' C'' D'' is the image of A' B' C' D' under a transformation matrix,

$$P = \begin{vmatrix} \frac{1}{2} & 1 \\ 1 & \frac{1}{2} \end{vmatrix}$$

- (i) Determine the coordinates of A", B", C" and D". (2 mks)
- (ii) On the same grid draw the quadrilateral A" B" C" D". (1 mk)
- (c) Find the area of A" B" C" D". (3 mks)
20. A parent has two children whose age difference is 5 years. Twice the sum of the ages of the two children is equal to the age of the parent.
- (a) Taking x to be the age of the elder child, write an expression for:
- (i) the age of the younger child; (1 mk)
- (ii) the age of the parent. (1 mk)
- (b) In twenty years time, the product of the children's ages will be 15 times the age of their parent.
- (i) Form an equation in x and hence determine the present possible ages of the elder child. (4 mks)
- (ii) Find the present possible ages of the parent. (2 mks)
- (iii) Determine the possible ages of the younger child in 20 years time. (2 mks)

21. The table below shows values of x and some values of y for the curve $y = x^3 + 2x^2 - 3x - 4$ for $-3 \leq x \leq 2$.

X	-3	-2.5	-2	-1.5	-1	-0.5	0	0.5	1	1.5	2
y	-4.0	-0.4		1.6	0		-4.0	9			6

- (a) Complete the table by filling in the missing values of y , correct to 1 decimal place. (2 mks)
- On the grid provided, draw the graph of $y = x^3 + 2x^2 - 3x - 4$.
- (b) Use the scale: 1 cm represents 0.5 units on x -axis.
1 cm represents 1 unit on y -axis. (3)

m
k
s)

- (c) Use the graph to:
- (i) solve the equation $x^3 + 2x^2 - 3x - 4 = 0$; (3 mks)
 - (ii) estimate the coordinates of the turning points of the curve. (2 mks)

- 22 The figure below represents a rectangular based pyramid VABCD.
 AB = 12 cm and AD = 16 cm. Point O is vertically below V and VA = 26 cm.

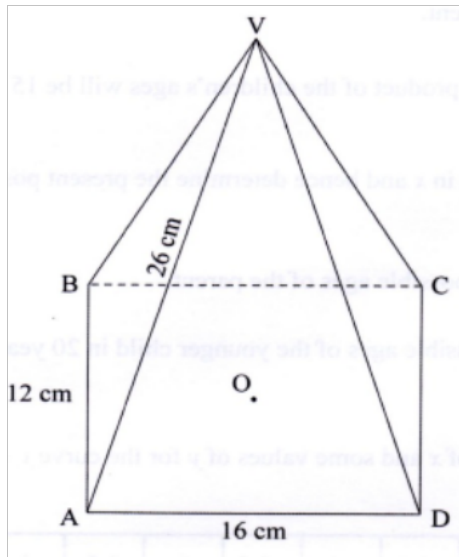

Calculate:

- (a) the height, VO, of the pyramid; (4 mks)
- (b) the angle between the edge VA and the plane ABCD; (3 mks)
- (c) the angle between the planes VAB and ABCD. (3 mks)

- 23 The cost C, of producing n items varies partly as n and partly as the inverse of n. To produce two items it costs Ksh 135 and to produce three items it costs Ksh 140. Find:

- (a) the constants of proportionality and hence write the equation connecting C and n; (5 mks)
- (b) the cost of producing 10 items; (2 mks)
- (c) the number of items produced at a cost of Ksh 756. (3 mks)

24. A building contractor has two lorries, P and Q, used to transport at least 42 tonnes of sand to a building site. Lorry P carries 4 tonnes of sand per trip while lorry Q carries 6 tonnes of sand per trip. Lorry P uses 2 litres of fuel per trip while lorry Q uses 4 litres of fuel per trip.

The two lorries are to use less than 32 litres of fuel. The number of trips made by lorry P should be less than 3 times the number of trips made by lorry Q. Lorry P should make more than 4 trips.

- (a) Taking x to represent the number of trips made by lorry P and y to represent the number of trips made by lorry Q, write the inequalities that represent the above information. (4 mks)
- (b) On the grid provided, draw the inequalities and shade the unwanted regions. (4 mks)
- (c) Use the graph drawn in (b) above to determine the number of trips made by lorry P and by lorry Q to deliver the greatest amount of sand. (2 mks)

MATHEMATICS
K.C.S.E PAPER 121/ 2 2012
QUESTIONS

SECTION I (50 marks)

Answer all the questions in this section

1. Evaluate $\frac{\log 4^5 - \log 5^4}{\log 4^{\frac{1}{5}} + 5^{\frac{1}{4}}}$

giving the answer to 4 significant figures.
(mks)

(2)

2. Make n the subject of the equation
(mks)

(3)

$$\frac{r}{p} = \frac{m}{\sqrt{n-1}}$$

3. An inlet tap can fill an empty tank in 6 hours. It takes 10 hours to fill the tank when the inlet tap and an outlet tap are both opened at the same time. Calculate the time the outlet tap takes to empty the full tank when the inlet tap is closed.
(mks)

(3)

4. Given that $P = 2i - 3j + k$, $Q = 3i - 4j - 3k$ and $R = 3P + 2Q$, find the magnitude of R to 2 significant figures.

(3 mks)

5. Solve the equation $\sin(2t + 10)^\circ = 0.5$ for $0^\circ \leq t \leq 180^\circ$

(2 mks)

6. Construct a circle centre x and radius 2.5 cm. Construct a tangent from a point P , 6 cm from x to touch the circle at R . Measure the length PR .
(mks)

(4)

7. Kago deposited Ksh 30 000 in a financial institution that paid simple interest

at the rate of 12% per annum. Nekesa deposited the same amount of money as Kago in another financial institution that paid compound interest. After 5 years, they had equal amounts of money in the financial institutions.

Determine the compound interest rate per annum, to 1 decimal place, for Nekesa's deposit. (4 mks)

8. The masses in kilograms of 20 bags of maize were;
90, 94, 96, 98, 99, 102, 105, 91, 102, 99, 105, 94, 99, 90, 94, 99, 98, 96, 102 and 105.

Using an assumed mean of 96kg, calculate the mean mass, per bag, of the maize. (3 mks)

9. Solve the equations $x + y = 17$
 $xy - 5x = 32$ (4 mks)

10. Simplify $\frac{\sqrt{5}}{\sqrt{5-2}}$ leaving the answer in the form where a, b and c are integers. (2 mks)

11. The base and height of a right angled triangle were measured as 6.4cm and 3.5 cm respectively. Calculate the maximum absolute error in the area of the triangle. (3 mks)

12. (a) Expand $(1 + x)^7$ up to the 4th term. (1 mk)

- (b) Use the expansion in part (a) above to find the approximate value of $(0.94)^7$. (2 mks)

- 13 The graph below shows the relationship between distance s metres and time t seconds in the interval $0 \leq t \leq 6$.

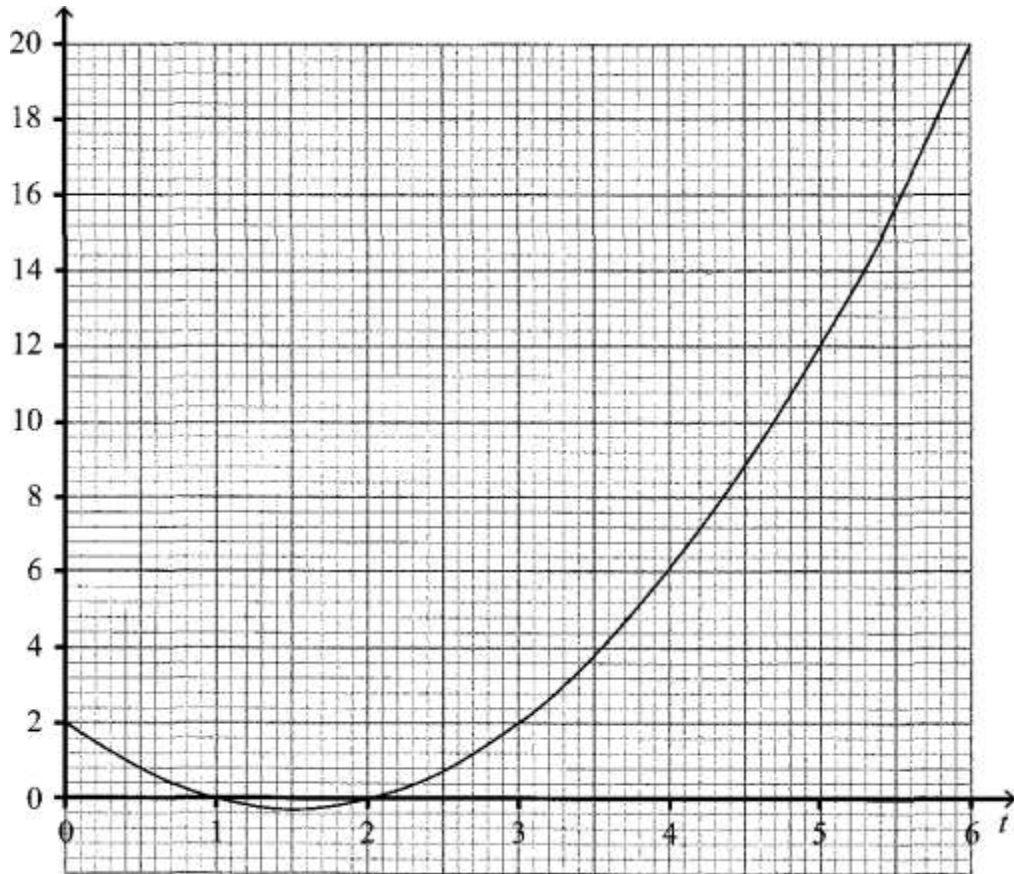

Use the graph to determine:

(a) the average rate of change of distance between $t = 3$ seconds and $t = 6$ seconds; (2 mks)

(b) the gradient at $t = 3$ seconds. (2 mks)

- 14 In the figure below, the tangent ST meets chord VU produced at T. Chord SW passes through the centre, O, of the circle and intersects chord VU at X. Line ST = 12 cm and UT = 8 cm

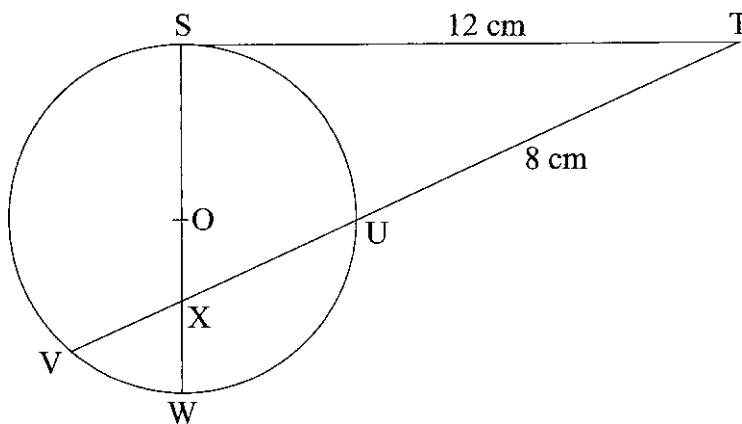

(a) Calculate the length of chord VU. (2 mks)

(b) If $WX = 3$ cm and $VX: XU = 2:3$, find SX . (2 mks)

15. Three quantities P, Q and R are such that P varies directly as Q and inversely as the square root of R. When $P = 8$, $Q = 10$ and $R = 16$. Determine the equation connecting P, Q and R. (3 mks)

16. In the figure below, VABCD is a right pyramid on a rectangular base. Point O is vertically below the vertex V $AB = 24\text{cm}$, $BC = 10\text{cm}$ and $CV = 26\text{cm}$.

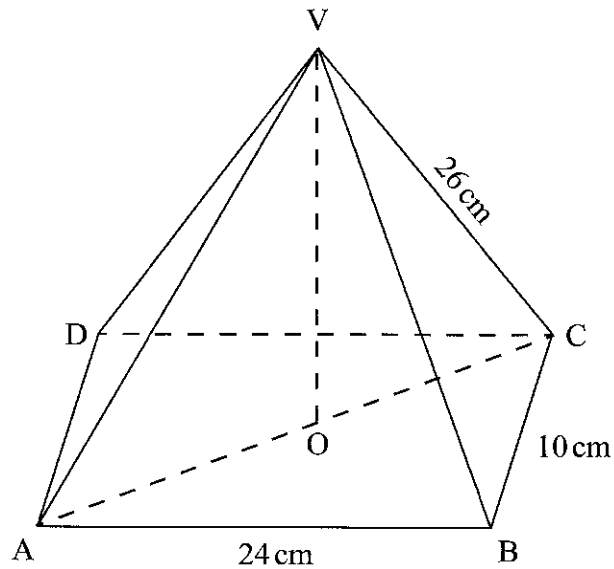

Calculate the angle between the edge CV and the base ABCD.

SECTION II (50 mks)

Answer only five questions in this section

17. Amaya was paid an initial salary of Ksh 180 000 per annum with a fixed annual increment. Bundi was paid an initial salary of Ksh 150000 per annum with a 10% increment compounded annually.
- (a) Given that Amaya's annual salary in the 11th year was Ksh 288 000, determine: (i) his annual increment; (2 mks)
- (ii) the total amount of money Amaya earned during the 11 years. (2 mks)
- (b) Determine Bundi's monthly earnings, correct to the nearest shilling, during

the eleventh year. (2
mks)

(c) Determine, correct to the nearest shilling:

(i) the total amount of money Bundi earned during the 11 years. (2
mks)

(ii) The difference between Bundi's and Amaya's average monthly earnings during the 11 years. (2 mks)

18. OABC is a parallelogram with vertices O(0,0), A(2,0), B(3,2) and C(1,2).

O'A'B'C' is the image of OABC under transformation matrix $\begin{bmatrix} -2 & 0 \\ 0 & -2 \end{bmatrix}$

(a) (i) Find the coordinates of O'A'B'C'. (2 mks)

(ii) On the grid provided draw O''A''B''C'' and O'A'B'C'.

(b) (i) Find O' 'A' B' C'', the image of O' A' B' C' under the transformation matrix $\begin{bmatrix} 1 & 0 \\ 0 & -2 \end{bmatrix}$ (2 mks)

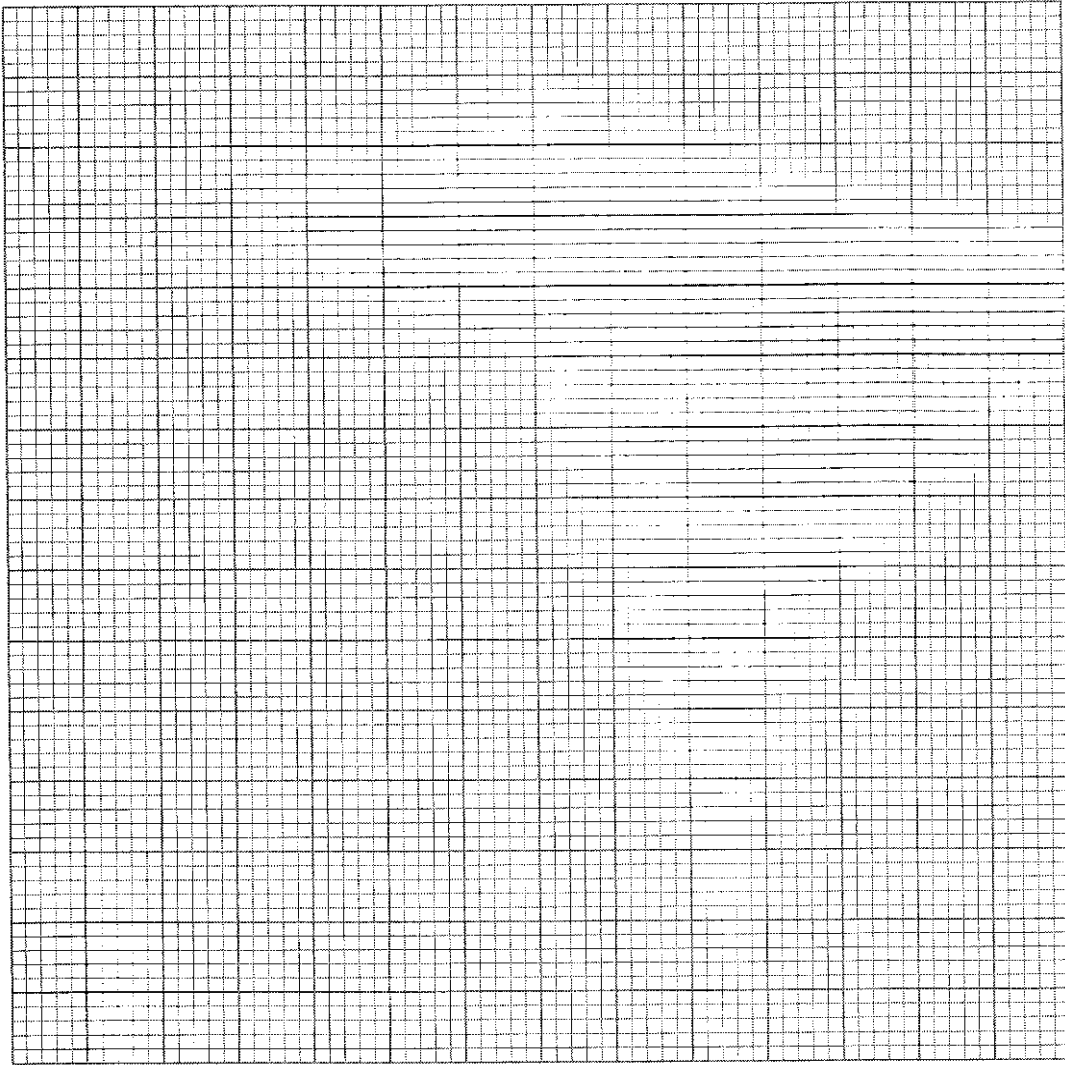

(ii) On the same grid draw $O''A''B''C''$. (1 mk)

(c) Find the single matrix that maps $O''A''B''C''$ onto $OABC$. (3 mks)

19. In triangle OPQ below, $OP = p$, $OQ = q$. Point M lies on OP such that $OM : MP = 2 : 3$ and point N lies on OQ such that $ON : NQ = 5 : 1$. Line PN intersects line MQ at X .

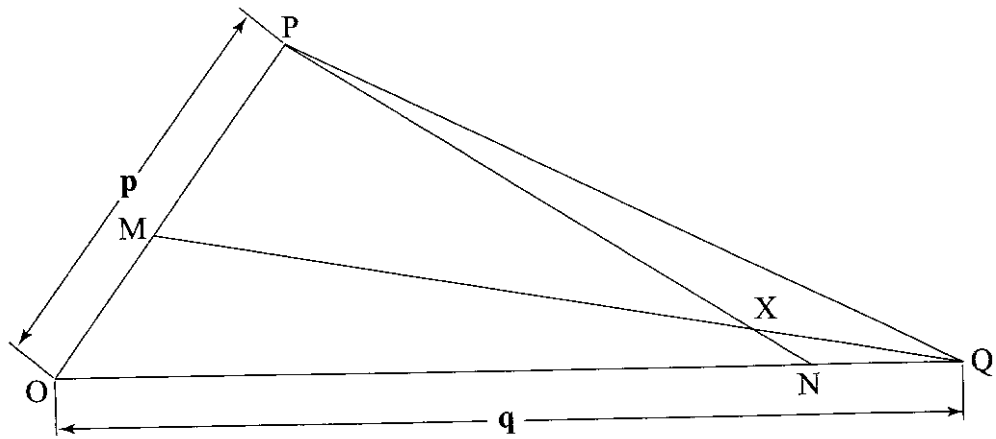

(a) Express in terms of p and q :

(i) PM

(ii) QM .

(c) Given that $PX = kPN$ and $QX = rQM$, where k and r are scalars:

(i) write two different expressions for OX in terms of p , q , k and r ; (2 mks)

(ii) find the values of k and r ; (4 mks)

(iii) determine the ratio in which X divides line MQ . (2 mks)

20. In June of a certain year, an employee's basic salary was Ksh 17000. The employee was also paid a house allowance of Ksh 6000, a commuter allowance of Ksh 2500 and a medical allowance of Ksh 1 800. In July of that year, the employee's basic salary was raised by 2%.

(a) Calculate the employees:

(i) basic salary for July; (2 mks)

- (ii) total taxable income in July of that year. (2 mks)

(b) In that year, the Income Tax Rates were as shown in the table below:

Monthly taxable income (Kshs)	Percentage rate of tax per shilling
Up to 9 680	10
From 9681 to 18800	15
From 18 801 to 27 920	20
From 27 921 to 37 040	25
From 37041 and above	30

Given that the Monthly Personal Relief was Ksh 1056, calculate the net tax paid by the employee. (6 mks)

21 (a) on the same diagram construct:

(i) triangle ABC such that $AB = 9$ cm, $AC = 7$ cm and angle $CAB = 60^\circ$; (2 mks)

(ii) the locus of a point P such that P is equidistant from A and B; (1 mk)

(iii) the locus of a point Q such that $CQ < 3.5$ cm. (1 mk)

(b) On the diagram in part (a):

(i) shade the region R, containing all the points enclosed by the locus of P and the locus of Q, such that $AP \geq BP$; (2 mks)

(ii) find the area of the region shaded in part (b)(i) above. (4 mks)

22 A tourist took 1 h 20 minutes to travel by an aircraft from town T(3°S , 35°E) to town U(9°N , 35°E). (Take the radius of the earth to be 6370km and $\pi = 22/7$)

- (a) Find the average speed of the aircraft. (3 mks)
- (b) After staying at town U for 30 minutes, the tourist took a second aircraft to town V(9°N, 5°E). The average speed of the second aircraft was 90% that of the first aircraft.
Determine the time, to the nearest minute, the aircraft took to travel from U to V (3 mks)
- (c) When the journey started at town T, the local time was 0700h. Find the local time at V when the tourist arrived. (4 mks)
- 23** A box contains 3 brown, 9 pink and 15 white clothes pegs. The pegs are identical except for the colour.
- (a) Find the probability of picking:
- (i) a brown peg; (1 mk)
- (ii) a pink or a white peg. (2 mks)
- (b) Two pegs are picked at random, one at a time, without replacement. Find the probability that:
- (i) a white peg and a brown peg are picked; (3 mks)
- (ii) both pegs are of the same colour. (4 mks)
- 24** The acceleration of a body moving along a straight line is $(4 - t) \text{ m/s}^2$ and its velocity is $v \text{ m/s}$ after t seconds.
- (a) (i) If the initial velocity of the body is 3 m/s, express the velocity v in terms of t . (3 mks)
- (ii) Find the velocity of the body after 2 seconds. (2 mks)
- (b) Calculate:

- (i) the time taken to attain maximum velocity; (2 mks)
- (ii) the distance covered by the body to attain the maximum velocity. (3 mks)

MATHEMATICS
K.C.S.E PAPER 121/ 2 2013
QUESTIONS

SECTION 1 (50 mks)

Answer all the question in this section

1. The sum of n terms of the sequence; 3, 9, 15, 21, ... is 7500. Determine the value of n (3 mks)
2. A quadratic curve passes through the points (-2, 0) and (1, 0). Find the equation of the curve in the form $y = ax^2 + bx + c$, where a , b and c are constants (2mks)
3. Make d the subject of the fomula,

$$P = \frac{1}{2}mn^2 - \frac{qd^2}{n}$$
 (3 mks)
4. Solve the equation

$$2 \log x - \log (x-2) = 2 \log 3.$$
 (3 mks)
5. (a) Using a pair of compasses and ruler only, construct an escribed circle to touch side XZ of triangle XYZ drawn below (3 mks)

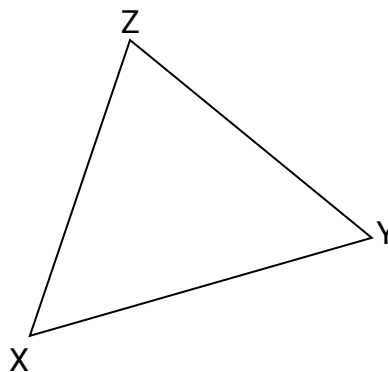

- (b) Measure the radius of the circle (1 mk)
6. The equation of a circle is given by $x^2 + 4x + y^2 - 2y - 4 = 0$. Determine the centre and radius of the circle (3 mks)
7. (a) expand $(1-x)^5$ (1 mk)
- (b) Use the expansion in (a) up to the term in x^3 to approximate the value of $(0.98)^5$ (2 mks)
8. The position vectors of points F, G, and H are \mathbf{f} , \mathbf{g} , and \mathbf{h} respectively. Point H divides FG in the ratio 4:-1. Express \mathbf{h} in terms of \mathbf{f} and \mathbf{g} (2 mks)
9. Two machines, M and N produce 60% and 40% respectively of the total number of items manufactured in a factory. It is observed that 5% of the items produced by machine M are defective while 3% of the items produced by machine N are defective.
- If an item is selected at random from the factory, find the probability that it is defective (3 mks)
10. Two taps A and B can each fill an empty tank in 3 hours and 2 hours respectively. A drainage tap R can empty the full tank in 6 hours; taps A and R are opened for 5 hours then closed.
- (a) Determine the fraction of the tank is still empty (2 mks)
- (b) Find how long it would take to fill the remaining fraction of the tank if all the three taps are opened (2 mks)
11. Simplify the expression $\frac{\sqrt{48}}{\sqrt{5+\sqrt{3}}}$ leaving the answer in the form $a\sqrt{b} + c$ where a, b and c are integers (3 mks)
12. A point P moves inside a sector of a circle, centre O, and chord AB such that $2\text{cm} < OP \leq 3\text{cm}$ and angle $APB = 65^\circ$ Draw the locus of P (4 mks)
13. The table below shows income tax rates in a certain year

Monthly income in Kenya shillings	Tax rate in each shilling
Up to 9 680	10%
From 9 681-18 800	15%
From 18 801 to 27 920	20%
From 27 921 to 37 040	25%
Over 37 040	30%

In that year, a monthly personal tax relief of kshs 1056 was allowed .calculate the monthly income tax paid by an employee who earned salary of Ksh 32 500. (4 mks)

14. Solve the equation

$$6 \cos^2 x + 7 \sin x - 8 = 0 \text{ for } 0^\circ \leq x \leq 90^\circ \quad (4 \text{ mks})$$

15. The position of two towns are ($2^\circ \text{ S}, 30^\circ \text{ E}$) and ($2^\circ \text{ S}, 37.4^\circ \text{ E}$) calculate , to the nearest km, the shortest distance between the two towns.(take the radius of the earth to be 6370 km)

(2 mks)

16. The vertices of triangle T are A(1, 2), B(4, 2) and C(3, 4). The vertices of triangle T', the image of T are A'(1/2, 1), B'(2, 1) and C'(3/2, 2).

Determine the transformation matrix $M = \begin{pmatrix} a & b \\ c & d \end{pmatrix}$ that maps T onto T'. (3

mks)

SECTION 11(50 MKS)

Answer only five questions from section

17. The hire purchase (H.P) price of a public address system was Kshs 276000. A deposit of Kshs 60000 was paid followed by 18 equal monthly installments. The cash price of the public address system was 10% less than the H.P price.

(a) Calculate

(i) The monthly installments (2 mks)

- (ii) The cash price (2 mks)
- (b) A customer decided to buy the system in cash and was allowed a 5% discount on the cash price. He took a bank loan to buy the system in cash. The bank charged compound interest on the loan at the rate of 20% p.a. The loan was repaid in 2 years. Calculate the amount repaid to the bank by the end of the second year (3 mks)
- (c) Express as a percentage of the Hire Purchase price, the difference between the amount repaid to the bank and the Hire Purchase price (3 mks)

18. In the figure below, PR is a diameter of the circle center O. Points P, Q, R and S are on the circumference of the circle. Angle PRQ = 72° , QS = QP and line USV is tangent to the circle at S.

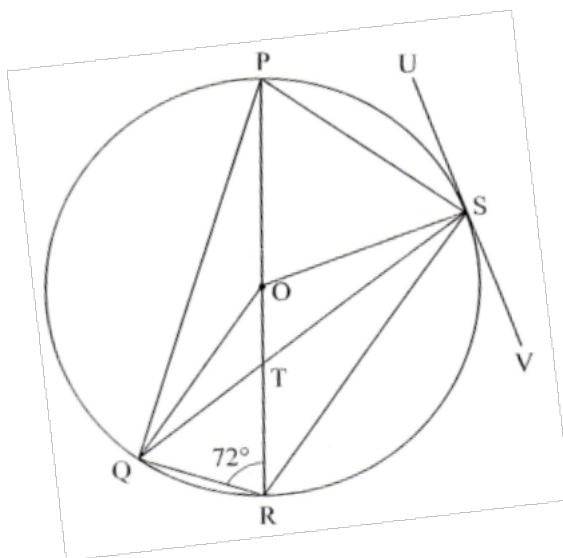

- Giving reasons, Calculate the size of
- (a) $\angle QPR$ (2 mks)
- (b) $\angle PQS$ (2 mks)
- (c) $\angle OQS$ (2 mks)

(d) < RTS (2 mks)

(e) < RSV (2 mks)

19. (a) Complete the table below for $y = x^3 + 4x^2 - 5x - 5$ (2 mks)

x	-5	-4	-3	-2	-1	0	1	2
$y = x^3 + 4x^2 - 5x - 5$			19			-5		

(b) On the grid provided, draw the graphs of $y = x^3 + 4x^2 - 5x - 5$ for $-5 \leq x \leq 2$ (3 mks)

(c) (i) Use the graph to solve the equation $x^3 + 4x^2 - 5x - 5 = 0$ (2 mks)

(ii) By drawing a suitable straight line on the graph, solve the equation $x^3 + 4x^2 - 5x - 5 = -4x - 1$ (3 mks)

20. The figure ABCDEF below represents a roof of a house. $AB = DC = 12$ m, $BC = AD = 6$ m, $AE = BF = CF = DE = 5$ m and $EF = 8$ m

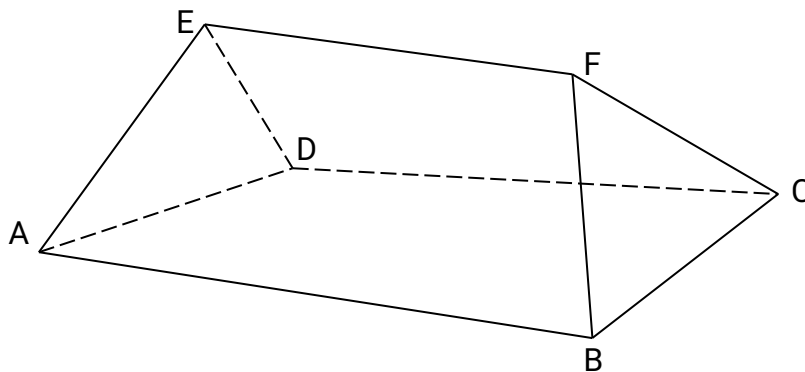

(a) Calculate, correct to 2 decimal places, the perpendicular distance of EF from the plane ABCD. (3 mks)

(b) calculate the angle between :

(i) the planes ADE and ABCD (2 mks)

(II) The line AE and the plane ABCD, correct to 1 decimal place; (2 mks)

(III) The planes ABFE and DEFE, correct to 1 decimal place. (3 mks)

21. (a) Complete the table below, giving the values correct to 1 decimal place. (2 mks)

χ°	0	40	80	120	160	200	240
$2 \sin(\chi + 20)^\circ$	0.7		2.0		0.0		-2.0
$\sqrt{3} \cos \chi$	1.7	1.3		-0.9		-1.6	

b) On the grid provided, using the same scale and axes, draw the graphs of $y = 2 \sin (\chi + 20)^\circ$ and $y = \sqrt{3} \cos \chi$ for $0^\circ \leq \chi \leq 240^\circ$. (5 mks)

c) Use the graphs drawn in (b) above to determine:

i) the value of χ for which $2 \sin (\chi + 20) = \sqrt{3} \cos \chi$; (2 mks)

ii) the difference in the amplitudes of $y = 2 \sin(\chi + 20)$ and $y = \sqrt{3} \cos \chi$. (1 mk)

22. Three quantities R, S, and T are such that R varies directly as S and inversely as the square of T.

a) Given that $R=480$ when $S=150$ and $T = 5$, write an equation connecting R, S and T. (4 mks)

b)(i) find the value of R when $S = 360$ and $T = 1.5$. (2mks)

(ii) Find the percentage change in R if S increases by 5% and T decreases by 20%. (4 mks)

(iii) the difference in the amplitudes of $y = 2 \sin (x + 20)$ and $y = \sqrt{3} \cos x$ (1 mk)

23. The equation of a curve is given by $y = 5x - \frac{1}{2}x^2$

(a) On the grid provided, draw the curve of $y = 5x - \frac{1}{2}x^2$ for $0 \leq x \leq 6$ (3 mks)

(b) By integration, find the area bounded by the curve, the line $x = 6$ and the x-axis. (3 mks)

(c) (i) On the same grid as in,(a).draw the line $y = 2x$. (1 mk)

(ii) Determine the area bounded by the curve and the line $y = 2x$. (3 mks)

24. The table below shows marks scored by 42 students in a test.

35	49	69	57	58	75	48
40	46	86	47	81	67	63
56	80	36	62	49	46	26
41	58	68	73	65	59	72
64	70	64	54	74	33	51
73	25	41	61	56	57	28

a) Starting with the mark of 25 and using equal class intervals of 10, make a frequency distribution table. (2mks)

b) On the grid provided , draw the ogive for the data (4 mks)

c) Using the graph in (b) above , estimate:

(i) The median mark (2 mks)

(ii) The upper quartile mark (2 mks)

MATHEMATICS

K.C.S.E PAPER 121/ 2 2014

QUESTIONS

SECTION I (50 marks)

Answer all the questions in this section

1. The lengths of two similar iron bars were given as 12.5m and 9.23m. Calculate

the maximum possible difference in length between the two bars.
(3 mks)

2. The first term of an arithmetic sequence is -7 and the common difference is 3 .

- (a) List the first six terms of the sequence;
- (b) Determine the sum of the first 50 terms of the sequence.

3. In the figure below, BOD is the diameter of the circle centre O. Angle ABD = 30° and angle AXD = 70° .

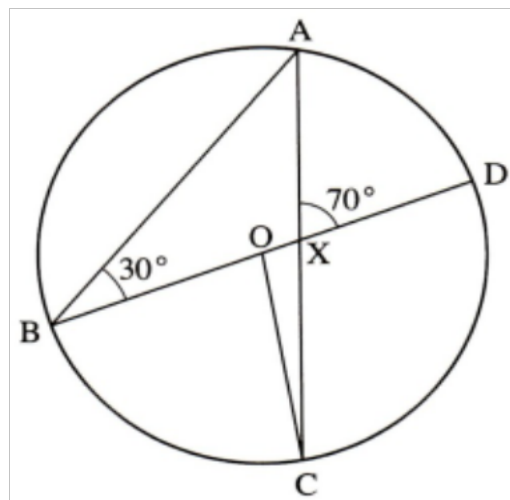

Determine the size of :

- a) Reflex angle BOC
- b) angle ACO.

(2mks)

(1mk)

4. Three quantities L, M and N are such that L varies directly as M and inversely as the square of N. Given that $L = 2$ when $M = 12$ and $N = 6$, determine the equation connecting the three quantities.

(3

mks)

5. The table below shows the frequency distribution of mks scored by students in a test.

Marks	Frequency
1-10	2
11-20	4

21-30	11
31-40	5
41-50	3

Determine the median mark correct to 2 s.f.
(2mks)

6. Determine the amplitude and period of the function, $y = 2 \cos (3x - 45)^\circ$.
(2mks)

7. In a transformation, an object with an area of 5 cm^2 is mapped onto an image whose area is 30 cm^2 . Given that the matrix of the transformation is

$$\begin{bmatrix} x & x-1 \\ 2 & 4 \end{bmatrix}, \text{ find the value of } x.$$

(3 mks)

8. Expand $(3 - x)^1$ up to the term containing x^4 . Hence find the approximate value of $(2.8)^7$.

(3 mks)

9. Solve the equation;

$$2 \log 15 - \log x = \log 5 + \log (x - 4).$$

(4 mks)

10. The figure below represents a cuboid PQRSTUUVW. PQ = 60cm, QR = 11 cm and RW - 10cm.

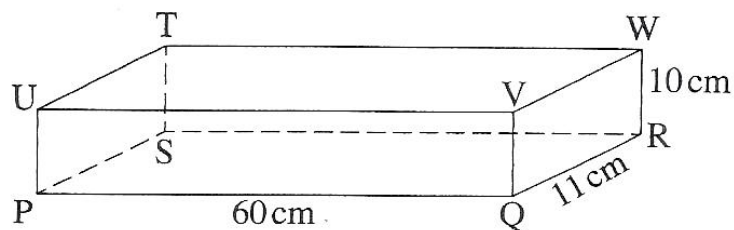

Calculate the angle between line PW and plane PQRS, correct to 2 decimal places.

(3mks)

11. Solve the simultaneous equations; $3x - y = 9$
 $x^2 - xy = 4$

(4mks)

12. Muga bought a plot of land for Ksh 280,000. After 4 years, the value of the plot was Ksh 495 000. Determine the rate of appreciation, per annum, correct to one decimal place. (3 mks)
13. The shortest distance between two points A (40°N, 20°W) and B (0°S, 20°W) on the surface of the earth is 8008km. Given that the radius of the earth is 6370km, determine the position of B. (Take $n = \frac{22}{7}$). (3 mks)
14. Vectors r and s are such that $r = 7i + 2j - k$ and $s = -i + j - k$. Find $|r + s|$. (3 mks)
15. The gradient of a curve is given by $\frac{dy}{dx} = x^2 - 4x^4 - 3$. The curve passes through the point (1,0). Find the equation of the curve. (3 mks).
16. The graph below shows the rate of cooling of a liquid with respect to time.

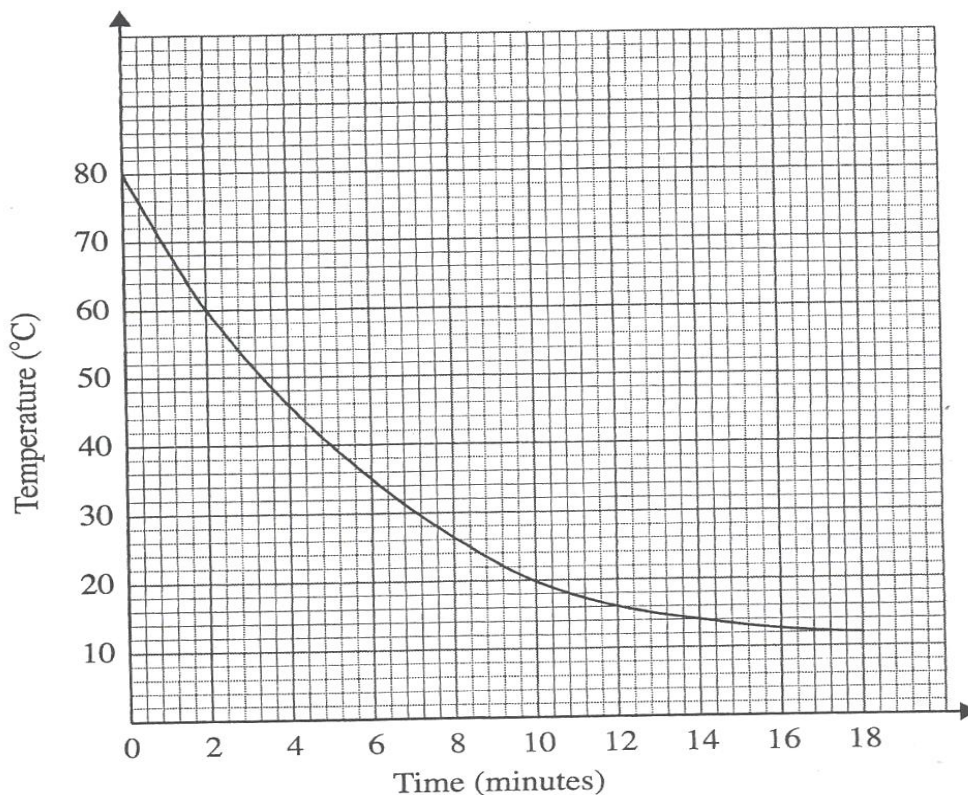

Determine the average rate of cooling of the liquid between the second and

the eleventh minutes.

(3mks)

SECTION II (50 mks)

Answer only five questions in this section

17 A paint dealer mixes three types of paint A, B and C, in the ratios $A:B = 3:4$ and $B:C = 1:2$. The mixture is to contain 168 litres of C.

- (a) Find the ratio $A:B:C$. (2 mks)
- (b) Find the required number of litres of B. (2 mks)
- (c) The cost per litre of type A is Ksh 160, type B is Ksh 205 and type C is Ksh 100.
- i. Calculate the cost per litre of the mixture. (2 mks)
- ii. Find the percentage profit if the selling price of the mixture is Ksh182 per litre. (2 mks)
- iii. Find the selling price of a litre of the mixture if the dealer makes a 25% profit. (2 mks)

18. In the figure below OS is the radius of the circle centre O. Chords SQ and TU are extended to meet at P and OR is perpendicular to QS at R. $OS = 61\text{cm}$, $PU=50\text{cm}$, $UT=40\text{cm}$ and $PQ = 30\text{cm}$.

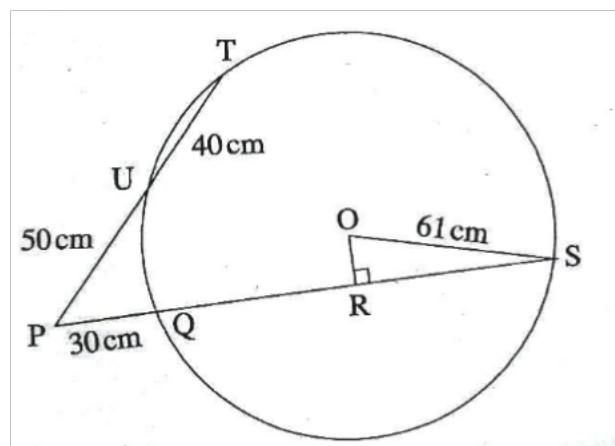

- a) Calculate the lengths of:
- i) QS: (2mks)
- ii) OR (3mks)

- c) Calculate, correct to 1 decimal place:
- i) The size of angle ROS: (2mks)
- ii) The length of the minor arc QS. (3mks)

19. The table below shows income tax rates for a certain year.

Monthly income in Kenya shillings (Ksh)	Tax rate in each shilling
0-10164	10%
10165-19740	15%
19741-29316	20%
29317-38892	25%
over 38892	30%

A tax relief of Ksh 1162 per month was allowed. In a certain month, of that year, an employee's taxable income in the fifth band was Ksh 2108.

- (a) Calculate:
- (i) the employee's total taxable income in that month; (2mks)
- (ii) the tax payable by the employee in that month. (2mks)
- (b) The employee's income included a house allowance of Ksh 15 000 per month. The employee contributed 5% of the basic salary to a co-operative society. Calculate the employees net pay for that month. (3 mks)
- 20 The dimensions of a rectangular floor of a proposed building are such that!
- the length is greater than the width but at most twice the width;
 - the sum of the width and the length is, more than 8 metres but less than 20 metres. If x represents the width and y the length.
- (a) write inequalities to represent the above information.

- (b) (i) Represent the inequalities in part (a) above on the grid provided.
- (ii) Using the integral values of x and y , find the maximum possible area of the floor. (2 mks)

21. Each morning Gataro does one of the following exercises: Cycling, jogging or weightlifting. He chooses the exercise to do by rolling a fair die. The faces of the die are numbered 1, 1,2, 3, 4 and 5.

If the score is 2, 3 or 5, he goes for cycling. If the score is 1, he goes for jogging. If the score is 4, he goes for weightlifting.

- (a) Find the probability that:
- (i) on a given morning, he goes for cycling or weightlifting;
- ii) on two consecutive mornings he goes for jogging

(b) In the afternoon, Gataro plays either football or hockey but never both games. The probability that Gataro plays hockey in the afternoon is:

$\frac{1}{3}$ if he cycled;

$\frac{2}{5}$ if he jogged and

$\frac{1}{2}$ if he did weightlifting in the morning.

Complete the tree diagram below by writing the appropriate probability on each branch.

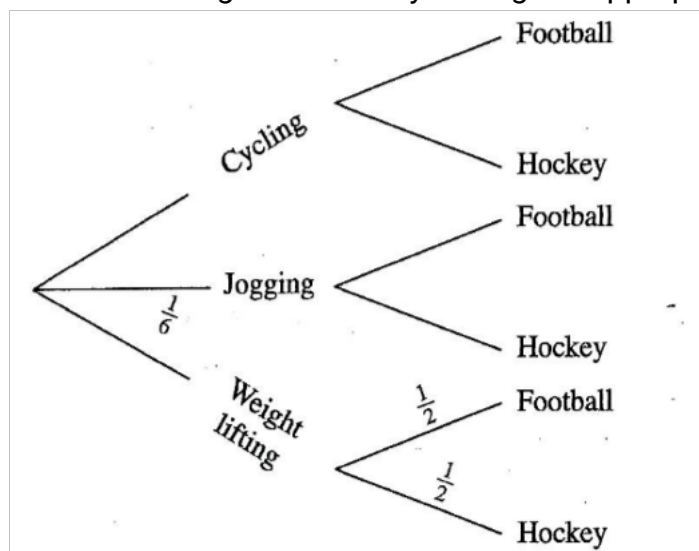

- (c) Find the probability that on any given day:
- (i) Gataro plays football; (2mks)

- (ii) Gataro neither jogs nor plays football.
(2mks)

22. In the figure below $OA = a$ and $OB = b$. M is the mid point of OA and $AN : NB = 2 : 1$

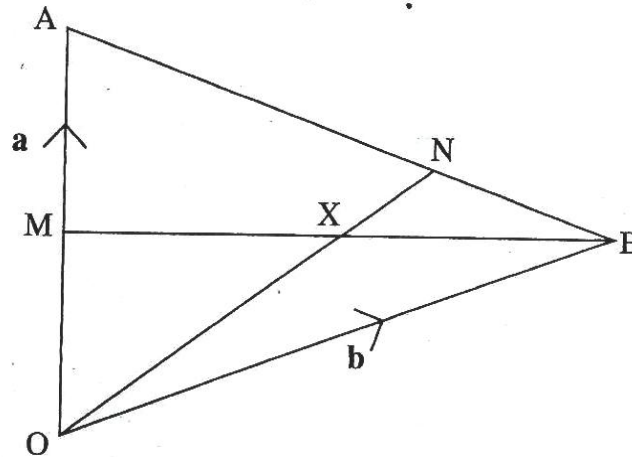

a) Express in terms of a and b :

- i) BA : (1mks)
 ii) BN : (1 mks)
 iii) ON (2 mks)

b) Given that $BX = hBM$ AND $OX = kON$ determine the values of h and k . (6mks)

23. Figure ABCD below is a scale drawing representing a square plot of side 80 metres.

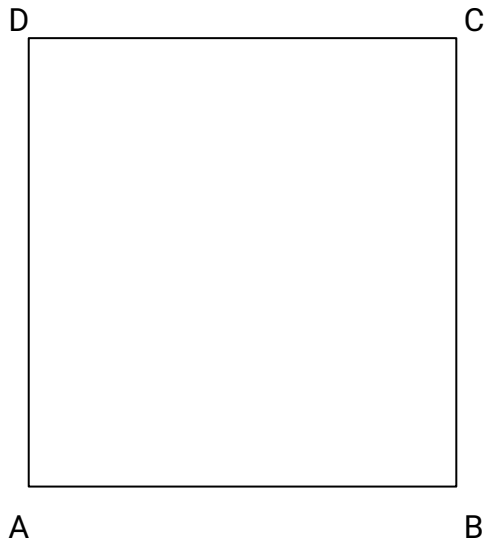

On the drawing, construct:

- (i) the locus of a point P , such that it is equidistant from AD and BC .
(2 mks)

(ii) the locus of a point Q such that $\angle AQB = 60^\circ$. (3 mks)

(i) Mk on the drawing the point Q, the intersection of the locus of Q and line AD.
Determine the length of BQ_1 in metres. (1 mk)

(ii) Calculate, correct to the nearest m^2 , the area of the region bounded by the locus of P, the locus of Q and the line BQ_1 (4 mks)

24 In an experiment involving two variables t and r, the following results were obtained

T	1.0	1.5	2.0	2.5	3.0	3.5
r	1.50	1.45	1.30	1.25	1.05	1.00

a) On the grid provided, draw the line of best fit for the data
(4mks)

b) The variables r and t are connected by the equation $r = at + k$ where a and k are constant

Determine

i) The values of a and K:

(3mks)

ii) The equation of the line of best fit.

(1mk)

iii) The value of t when $r = 0$

(2mks)

MATHEMATICS
K.C.S.E PAPER 121/ 2 2015
QUESTIONS

SECTION I (50 marks)
Answer all the questions in this section

1. The length and width of a rectangular piece of paper were measured as 60 cm and 12 cm respectively. Determine the relative error in the calculation of its area. (4 mks)

2. Simplify $\frac{\sqrt{11}}{\sqrt{11-\sqrt{7}}}$

3. An arc 11 cm long, subtends an angle of 70° at the centre of a circle. Calculate the length, correct to one decimal place, of a chord that subtends an angle of 90° at the centre of the same circle. (4 mks)

4. In the figure below, O is the centre of the circle. A, B, C and D are points on the circumference of the circle. Line AB is parallel to line DC and angle $ADC = 55^\circ$. Determine the size of angle ACB (3 mks)

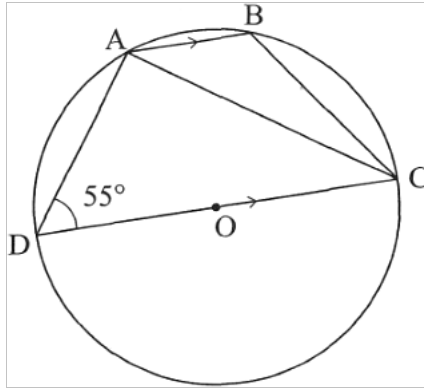

5. Eleven people can complete $\frac{3}{5}$ of a certain job in 24 hours. Determine the time in hours, correct to 2 decimal places, that 7 people working at the same rate can take to complete the remaining job. (3 mks)
6. The length and width of a rectangular signboard are $(3x + 12)$ cm and $(x - 4)$ cm respectively.
If the diagonal of the signboard is 200cm, determine its area. (4 mks)
7. Find the value of x given that $\log(x - 1) + 2 = \log(3x + 2) + \log 25$. (3 mks)
8. Use the expansion of $(x - y)^5$ to evaluate $(9.8)^5$ correct to 4 decimal places. (3 mks)
9. The diameter of a circle, centre O has its end points at $M(-1, 6)$ and $N(5, -2)$.
Find the, equation of the circle in the form $x^2 + y^2 + ax + by = c$ where a , b and c are constants (4 mks)
10. Below is a line AB and a point X . Determine the locus of a point P equidistant from points A and B and 4 cm from X . (3 mks)

-X



11. In a nomination for a committee, two people were to be selected at random from a group of 3 men and 5 women. Find the probability that a man and a woman were selected (2 mks)
12. A school decided to buy at least 32 bags of maize and beans. The number of bags of maize were to be more than 20 and the number of bags of beans were to be at least 6. A bag of maize costs Ksh 2500 and a bag of beans costs Ksh 3500. The school had Ksh 100 000 to purchase the maize and beans. Write down all the inequalities that satisfy the above information. (4 mks)
13. Evaluate $\int_2^4 x^2 + 2x - 15 dx$ (3 mks)
14. The positions of two points P and Q, on the surface of the earth are P(45 °N, 36°E) and Q(45 °N, 71°E). Calculate the distance, in nautical miles, between P and Q, correct to 1 decimal place. (3 mks)
15. Solve the equation $\sin(\frac{1}{2}x - 30^\circ) = \cos x$ for $0 < x < 90^\circ$. (2 mks)
16. The position vectors of points P, Q and R are $OP = \begin{bmatrix} -3 \\ 6 \end{bmatrix}$, $OQ = \begin{bmatrix} 2 \\ 1 \end{bmatrix}$ = $OR = \begin{bmatrix} 4 \\ -1 \end{bmatrix}$
Show that P, Q and R are collinear. (3 mks)

SECTION II (50 marks)

Answer any five questions from this section

17. In a retail shop, the marked price of a cooker was Ksh 36 000. Wanandi bought the cooker on hire purchase terms. She paid Ksh 6400 as deposit followed by 20 equal monthly installments of Ksh 1750.
- (a) Calculate:
- (i) The total amount of money she paid for the cooker. (2 mks)
- (ii) The extra amount of money she paid above the marked price. (1 mk)
- (b) The total amount of money paid on hire purchase terms was calculated at a Compound interest rate on the marked price for 20 months. Determine the rate, per annum, of the compound interest correct to 1 decimal place. (4 mks)

mks)

- c) Kaloki borrowed kshs 36000 from a financial institution to purchase a similar cooker. The financial institution charged a compound interest rate equal to the rate in (b) above for 24 months. Calculate the interest kaloki paid correct to the nearest shilling. (3mks)

18. Mute cycled to raise funds for a charitable organisation. On the first day, he cycled 40 km. For the first 10 days, he cycled 3 km less on each subsequent day. Thereafter, he cycled 2km less on each subsequent day.

a) Calculate

- i) the distance cycled on the 10th day (2 mks)
ii) The distance cycled on the 16th day (3 mks)

b) If Mute raised kshs 200 per km, calculate the amount of money collected (5 mks)

19 The equation of a curve is given by $y = 1 + 3\sin x$.

(a) Complete the table below for $y = 1 + 3 \sin x$ correct to 1 decimal place

x°	0	30	60	90	120	150	180	210	240	270	300	330	360
$y = 1 + 3 \sin x$	1		3.6				1	-0.5			-1.6		

- (b) (i) On the grid provided, draw the graph of $y = 1 + 3 \sin x$ for $0 \leq x \leq 360^\circ$. (3 mks)
ii) State the amplitude of the curve $y = 1 + 3 \sin x$. (1 mk)

c) On the same grid draw the graph of $y = \tan x$ for $90^\circ \leq x \leq 270^\circ$. (3 mks)

d) Use the graphs to solve the equation $1 + 3 \sin x = \tan x$ for $90^\circ \leq x \leq 270^\circ$. (1

mk)

20. The figure below represents a cuboid EFGHJKLM in which EF = 40cm, FG=9cm and GM=30 cm. N is the midpoint of LM.

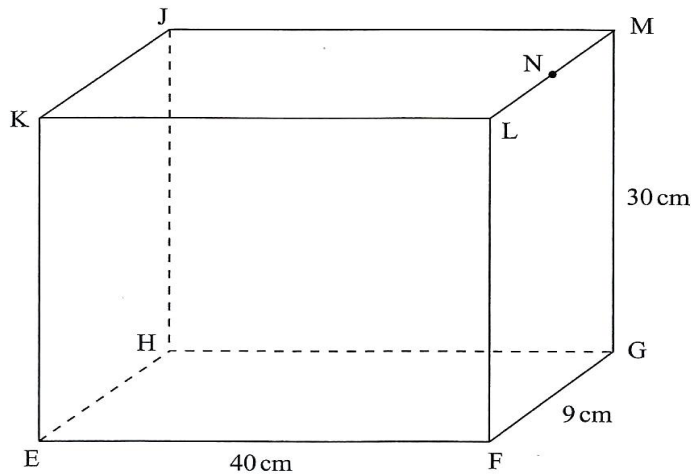

Calculate correct to 4 significant figures

- a) The length of GL: (1 mk)
- b) The length of FJ (2 mks)
- c) The angle between EM and the plane EFGH; (3 mks)
- d) The angle between the planes EFGH and ENH; (2 mks)
- e) the angle between the lines EH and GL (2 mks)

21. A quantity P varies partly as the square of m and partly as n. When P = 3.8, m = 2 and n = 2. When P = -0.2, m = 3 and n = 2.

- (a) Find:
 - (i) the equation that connects P, m and n; (4 mks)
 - (ii) the value of P when m = 10 and n = 4. (1 mk)
- (b) Express m in terms of P and n. (2 mk)
- (c) If P and n are each increased by 10%, find the percentage increase in m correct to 2 decimal places. (3 mks)

22. A particle was moving along a straight line. The acceleration of the particle after t seconds was given by $(9 - 3t) \text{ ms}^{-2}$. The initial velocity of the particle was 7 ms^{-1} .

- Find:
- a) the velocity (v) of the particle at any given time (t); (4 mks)

b) The maximum velocity of the particle; (3 mks)

c) the distance covered by the particle by the time it attained maximum velocity (3 mks)

23. The marks scored by 40 students in a mathematics test were as shown in the table below.

Marks	48-52	53-57	58-62	63-67	68-72	73-77
Number of	3	4	10	12	8	3

a) Find the lower class boundary of the modal class (1 mks)

b) Using an assumed mean of 64, calculate the mean mark (3 mks)

c i) On the grid provided, draw the cumulative frequency curve for the data (3 mks)

ii) Use the graph to estimate the semi-interquartile range (3 mks)

24. A quadrilateral with vertices at K (1,1), L(4,1), M(2, 3) and N (1, 3) is transformed

by a matrix $T = \begin{bmatrix} 1 & 3 \\ 0 & 1 \end{bmatrix}$ to a quadrilateral K'L'M'N'

a) Determine the coordinates of the image (3 mks)

b) On the grid provided draw the object and the image (2 mks)

c i) Describe fully the transformation which maps KLMN onto K'L'M'N' (2 mks)

ii) Determine the area of the image. (1 mk)

d) Find a matrix which maps K'L'M'N' onto KLMN (2 mks)

MATHEMATICS
K.C.S.E PAPER 121/ 2 2016
QUESTIONS

SECTION 1 (50 MKS)

Answer all the questions from this section in the spaces provided

1. Simplify $\frac{4}{\sqrt{5+\sqrt{2}}} - \frac{3}{\sqrt{5-\sqrt{2}}}$ (3 mks)

2. By correcting each number to one significant figure, approximate the value of 788×0.0006 . hence calculate the percentage error arising from this approximation (3 mks)

3. The area of triangle FGH is 21cm^2 . The triangle FGH is transformed using the matrix

$$\begin{bmatrix} 4 & 5 \\ 1 & 2 \end{bmatrix}$$

Calculate the area of the image of triangle FGH (2 mks)

4. Make s the subject of the formula

(3mks)

$$W = 3\sqrt{\frac{s+t}{s}}$$

5. Solve the equation

$$2 \log x - \log (x - 2) = 2 \log 3. \quad (3 \text{ mks})$$

6. Kago deposited kshs 30000 in a financial institution that paid simple interest at the rate of 12% per annum. Nekesa deposited the same amount of money as Kago in another financial institution that paid compound interest. After 5 years, they had equal amounts of money in the financial institutions.

Determine the compound interest rate, to 1 decimal place for Nekesas deposit (4

mks)

7. The masses in kilograms of 20 bags of maize were:

90, 94, 96, 98, 99, 102, 105, 91, 102, 99, 105, 94, 99, 90, 94, 99, 98, 96, 102 and 105.

Using an assumed mean of 96 kg, calculate the mean mass, per bag of the maize.

(3 mks)

8. The first term of an arithmetic sequence is -7 and the common difference is 3

(a) List the first six terms of the sequence; (1

mk)

(b) Determine the sum of the first 50 terms of the sequence. (2 mks)

9. A bag contains 2 white balls and 3 black balls. A second bag contains 3 white balls and 2 black balls. The balls are identical except for the colours. Two balls are drawn at-random, one after the other from the first bag and placed in the second bag.

Calculate the probability that the 2 balls are both white. (2 mks)

10. An arc 11 cm long, subtends an angle of 70° at the centre of a circle. Calculate the length, correct to one decimal place, of a chord that subtends an angle of 90° at the centre of the same circle. (4

mks)

11. Given that $qi + \frac{1}{3}j + \frac{2}{3}k$ is a unit vector, find q. (2 mks)

12. (a) Expand the expression $\left(1 + \frac{1}{2}x\right)^5$ in ascending powers of x, leaving the coefficients as fractions in their simplest form. (2

mks)

(b) Use the first three terms of the expansion in (a) above to estimate the value

Of $\left(1 + \frac{1}{20}\right)^5$ (2 mks)

13. A circle whose equation is $(x - 1)^2 + (y - k)^2 = 10$ passes through the point (2,5).

Find the value of k. (3 mks)

14. Water and milk are mixed such that the volume of water to that of milk is 4:1, Taking the density of water as 1 g/cm^3 and that of milk as 1.2 g/cm^3 , find the mass in grams of 2.5 litres of the mixture. (3

mks)

15. A school decided to buy at least 32 bags of maize and beans. The number of bags of beans were to be at least 6. A bag of maize costs Ksh 2500 and a bag of beans costs Ksh 3500, The school had Ksh 100 000 to purchase the maize and beans. Write down all the inequalities that satisfy the above information, (4

mks)

16. Find in radians, the values of x in the interval $0^\circ \leq x < 2\pi^\circ$ for which $2 \cos^2 x - \sin x = 1$. (Leave the answer in terms of π) (4

mks)

SECTION II (50 marks)

Answer any five questions from this section in the spaces provided

17. A garden measures 10 m long and 8 m wide. A path of uniform width is made all round the garden. The total area of the garden and the path is 168 m^2 . (a) Find the width of the path. (4 mks)

b) The path is to be covered with square concrete slabs. Each corner of the path is covered with a slab whose side is equal to the width of the path. The rest of the path is covered with slabs of side 50cm. The cost of making each corner slab is Sh 600 while the cost of making each smaller slab is Sh 50.

Calculate;

(i) the number of the smaller slabs used. (3 mks)

(ii) the total cost of the slabs used to cover the whole path. (3

mks)

18. In the figure below, P, Q, R and S are points on the circle with centre O. PRT and USTV are straight lines. Line USTV is a tangent to the circle at S. $\angle RST = 50^\circ$ and $\angle RTV = 150^\circ$.

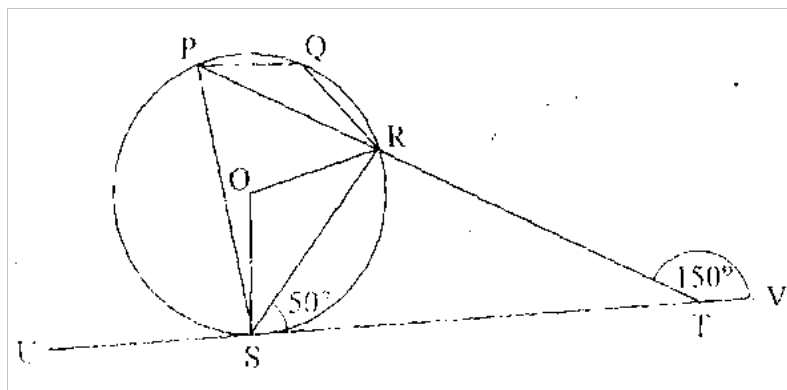

a) Calculate the size of

- | | |
|-------------------|---------|
| i) $\angle QRS$ | (2 mks) |
| ii) $\angle USP$ | (1mk) |
| iii) $\angle PQR$ | (2 mks) |

b) Given that $RT = 7$ cm and $ST = 9$ cm, calculate to 3 significant figures

- | | |
|------------------------------|---------|
| i) Length of line PR | (2 mks) |
| ii) The radius of the circle | (3 mks) |

19. The figure ABCDEF below represents a roof of a house

$AB = DC = 12$ m, $BC = AD = 6$ m, $AE = BF = CF = DE = 5$ m and $EF = 8$ m

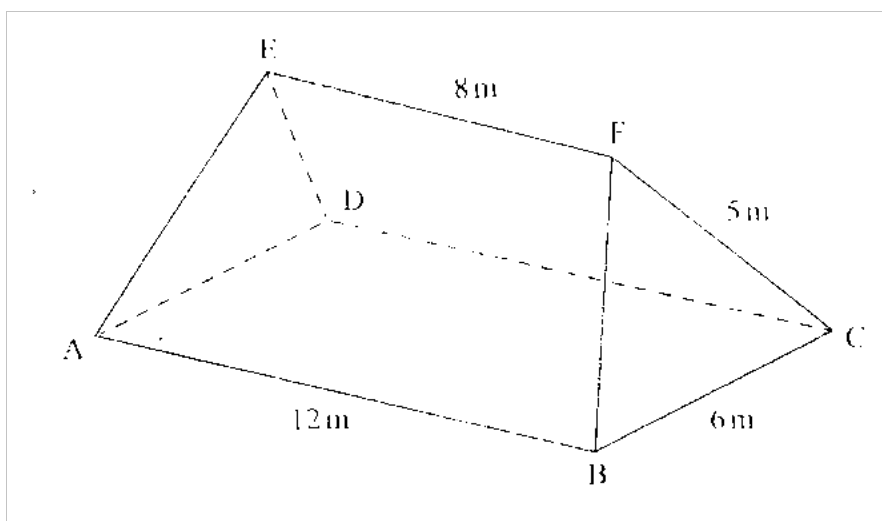

a) Calculate correct to 2 decimal places, the perpendicular distance of EF from the

plane ABCD (4 mks)

b) Calculate the angle between

i) The planes ADE and ABCD (2 mks)

ii) The line AE and the plane ABCD, correct to 1 decimal place (2 mks)

iii) The planes ABFE and DCFE, correct to 1 decimal place. (2 mks)

20. A water vendor has a tank of capacity 18 900 litres. The tank is being filled with water from two pipes A and B which are closed immediately when the tank is full. Water flows at the rate of $150\,000\text{cm}^3/\text{minute}$ through pipe A and $120\,000\text{cm}^3/\text{minute}$ through pipe B.

(a) If the tank is empty and the two pipes are opened at the same time, calculate the time it takes to fill the tank (3 mks)

(b) On a certain day the vendor opened the two pipes A and B to fill the empty tank. After 25 minutes he opened the outlet tap to supply water to his customers at an average rate of 20 litres per minute.

(i) Calculate the time it took to fill the tank on that day. (4 mks)

(ii) The vendor supplied a total of 542 jerricans, each containing 25 litres of water, on that day. If the water that remained in the tank was 6300 litres, calculate, in litres, the amount of water that was wasted. (3 mks)

21. A tourist took 1 hour 20 minutes to travel by an aircraft from town T(3°S , 35°E) to town U(9°N 35°E). (Take the radius of the earth to be 6370km and $\pi = \frac{22}{7}$)

(a) Find the average speed of the aircraft. (3

mks)

- (a) After staying at town U for 30 minutes, the tourist took a second aircraft to town V(9°N, 5°E), The average speed of the second aircraft was 90% that of the first aircraft Determine the time, to the nearest minute, the aircraft took to travel from U to V. (3 mks)
- (c) When the journey started at town T, the local time was 0700h. Find the local time at V when the tourist arrived. (4 mks)

22. The gradient function of a curve is given by the expression $2x + 1$. If the curve passes through the point $(-4, 6)$;

a)Find

- i)The equation of the curve (3 mks)
- ii)The value of x at which the curve cuts the $x - axis$ (3mks)
- iii) Determine the area enclosed by the curve and the $x - axis$ (4 mks)

23. A quadrilateral with vertices at $K(1,1)$, $L(4,1)$, $M(2,3)$ and $M(1,3)$ is transformed by a matrix. $T = \begin{pmatrix} 1 & 3 \\ 0 & 1 \end{pmatrix}$ to a quadrilateral $K'L'M'N'$.

- a) Determine the coordinates of the image (3 mks)

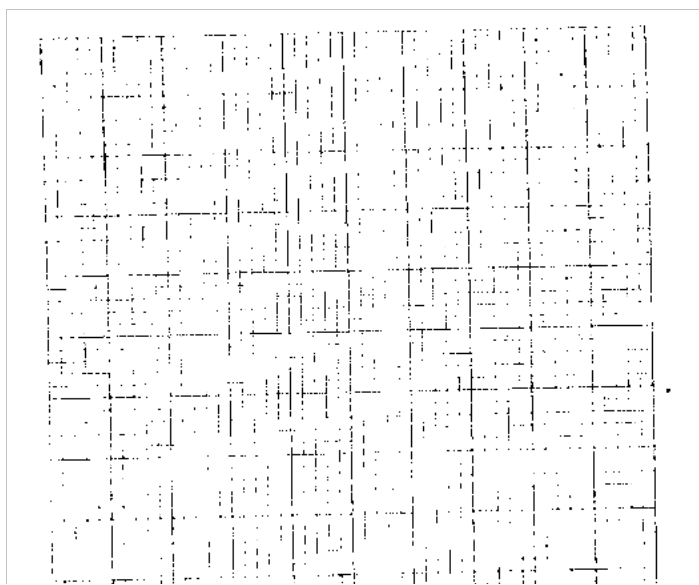

For mar

c)i) Describe fully the transformation which maps KLMN onto K'L'M'N' (2 mks)

ii) Determine the area of the image (1mk)

d) Find a matrix which maps K'L'M'N' onto KLMN. (2 mks)

24. The first, fifth and seventh terms of an arithmetic progression (AP) correspond to the first three consecutive terms of a decreasing Geometric Progression (G.P.)
The first term of each progression, is 64, the common difference of the AP is d and the common ratio of the G.P. is r

a i) Write two equation involving d and r (2 mks)

ii) Find the values of d and r (4 mks)

b) Find the sum of the first 10 terms of

i) The arithmetic progression(A.P);
(2mks)

ii)The Geometric Progression (G.P) (2 mks)



'an investment of knowledge pays

The following **KASNEB** notes are available;

 **ATD**

 **CPA**

 **CS**

 **CIFA**

Call Mdm.Mariam;0746711892 to acquire them

