

# KCSE 2022 PREDICTION



## ALL SUBJECTS



### SUBJECTS PREDICTED INCLUDE;

SET 1

*Mathematics, English, Kiswahili, CRE, Geography, History, Biology, Chemistry, Physics,  
French, Agriculture, Business, Computer, IRE, German, Home-Science & Power  
Mechanics.*

***In-Depth set of Detailed Comprehensive Possible Expected  
Testable Questions/Areas Predicted By TOP KNEC Examiners to  
ALL NATIONAL SCHOOLS.***

***We Expect Part of, If Not All of These Questions in the Scheduled  
KCSE 2021 EXAMINATIONS In April 2022.***

## **CONFIDENTIAL!**

**FOR MARKING SCHEMES/ANSWERS**

**CALL/WHATSAPP 0707550000 / 0705525657**

***SUCCESS TO ALL KCSE CANDIDATES!***

# KCSE 2021 PREDICTION

NAME.....

INDEX NO.....

SCHOOL.....

SIGN.....

DATE.....

231/1

# BIOLOGY

(THEORY)

PAPER 1

TIME: 2 HOURS

### Instructions to candidates

1. Write your **name**, **index number** and the **name** of your school in the spaces provided above.
2. Sign and write the **date** of examination in the spaces provided above.
3. Answer **all** questions in this question paper.

### For Examiner's Use Only

Questions	Maximum Score	Candidate's Score
1-30	80	



1. **Name** the organelles that would be most likely found in large numbers in cells that perform the functions below. (2mks)

(a) A cell in the ileum that actively takes in glucose.

.....  
.....

(b) A cell in the liver that breaks down foreign bodies.

.....  
.....

2. A doctor added a few drops of anti B-serum to two samples of blood in a blood test. No agglutination occurred. **Name** the blood groups of the blood samples. (2mks)

.....  
.....  
.....

3. **State** the significance of metamorphosis in insects. (3mks)

.....  
.....  
.....  
.....

4. **State three** structural differences between muscles alimentary canal and biceps muscles. (3mks)

.....  
.....

.....  
.....  
.....

5. The dental formula of a certain animal is an organism was found to have the dental formula:

$$\begin{array}{cccc} \text{i} & \frac{1}{1} & \text{C} & \frac{0}{0} & \text{P} & \frac{3}{2} & \text{M} & \frac{4}{4} \end{array}$$

(i) Suggest the mode of feeding of the animal (1mk)

.....  
.....  
.....

(ii) Give a reason for your answer in part (i) above (1mk)

.....  
.....  
.....

6. In an accident a victim suffered damage of his internal organs, consequently he started having excess glucose in his blood.

(a) Which organ was damaged? (1mk)

.....  
.....  
.....



(b) Give a reason for your answer

(1mk)

.....

.....

.....

7. Name two structures in plants where meiosis occurs

(2mks)

.....

.....

.....

8. The diagram below represents a reflex arc in human

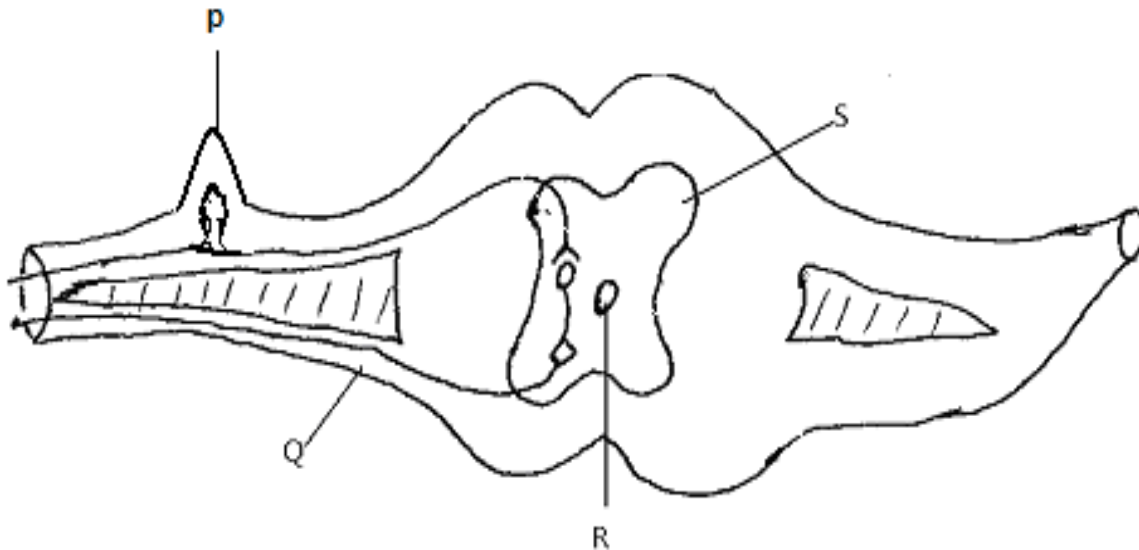

(a) Name the parts labelled P and S

(2mks)

P :

.....

**S:** .....

(b) **State** the function of the parts labelled **Q** (1mk)

.....  
.....  
.....

(c) Part **R** contains some type of fluid. Name the fluid. (1mk)

.....  
.....

9. **State three** roles of diffusion in plants (3mks)

.....  
.....  
.....

10. During the first phase of respiration, a glucose molecule is broken down into pyruvic acid and a small amount of energy is produced.

(a) **Name** the process described above. (1mk)

.....  
.....  
.....



(b) **State** where the process you have name in (a) above takes place in a cell. (1mk)

.....  
.....

11. The energy used by a hawk for flying is obtained indirectly from the sun. **Explain.**

(3mks)

.....  
.....  
.....  
.....

12. The flippers of whales and fins of the fish adapt these organisms to aquatic habitats.

(a) **Name** the evolutionary process that may have given rise to such structures. (1mk)

.....  
.....  
.....

(b) **What** name is given to such structures? (1mk)

.....  
.....  
.....



13. In an experiment to investigate an aspect of digestion, two test tubes A and B were set up as shown in the diagram below

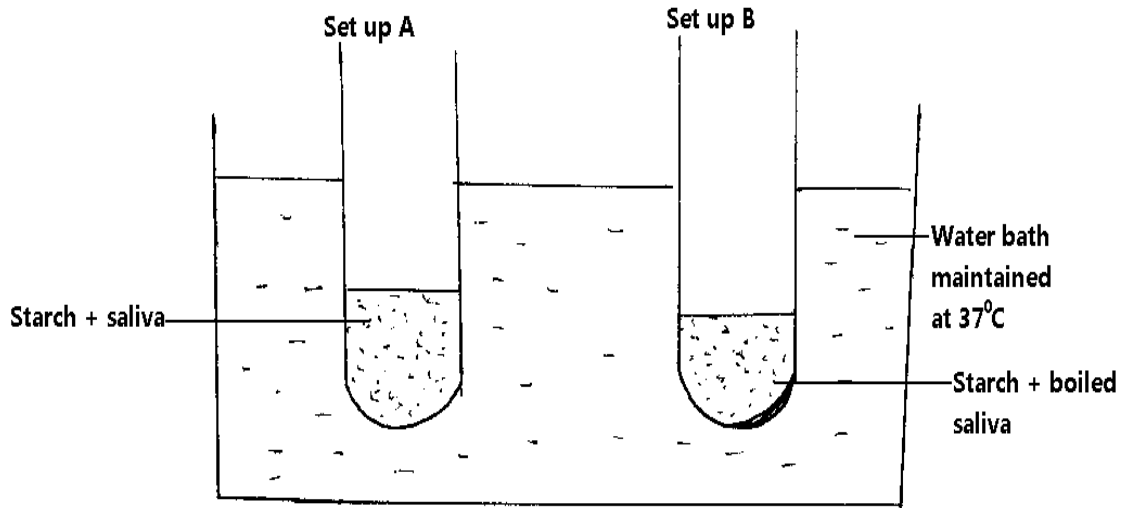

The test tubes were left in the water bath for 30 minutes. The content of each test tube was then tested for starch using iodine solution.

(a) What was the aim of the experiment? (1mk)

.....  
.....  
.....

(b) What results were expected in test tubes A and B (2mks)

Set-up A .....

Set-up B .....



(c) Why was the set-up maintained at 37°C. (1mk)

.....

.....

.....

14. Explain how drooping of leaves in a hot sunny day is advantageous to a plant. (2mks)

.....

.....

.....

.....

15. State two classes of the phylum arthropoda in which the body is divided into cephalothorax and abdomen. (2mks)

.....

.....

.....

16. (a) What is co-dominance? (1mk)

.....

.....

.....

(b) Name two disorders in human blood that are caused by gene mutation. (2mks)

.....

.....



17. Describe what happens during the dark stage of photosynthesis

(3mks)

.....

.....

.....

.....

.....

18. The diagram below represents a structure found in plants.

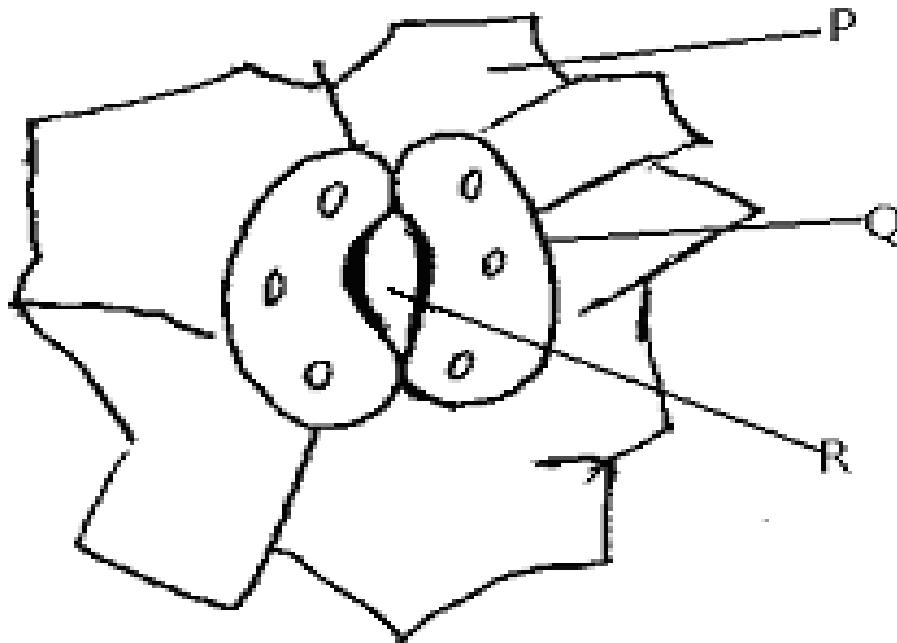

(a) Name the parts labelled **P** and **R**

(2mks)

**P** .....

**R** .....

(b) State how part Q is adapted to its function

(2mks)

.....  
.....  
.....

19. A certain species of flowering plant relies entirely on sexual reproduction for propagation. The chromosome number of the cell in the ovarian wall is 16.

State the chromosome number of

(a) The pollen tube nucleus

(1mk)

.....  
.....

(b) A cell of the endosperm

(1mk)

.....  
.....

20. The diagram below represents germination of a certain seed.

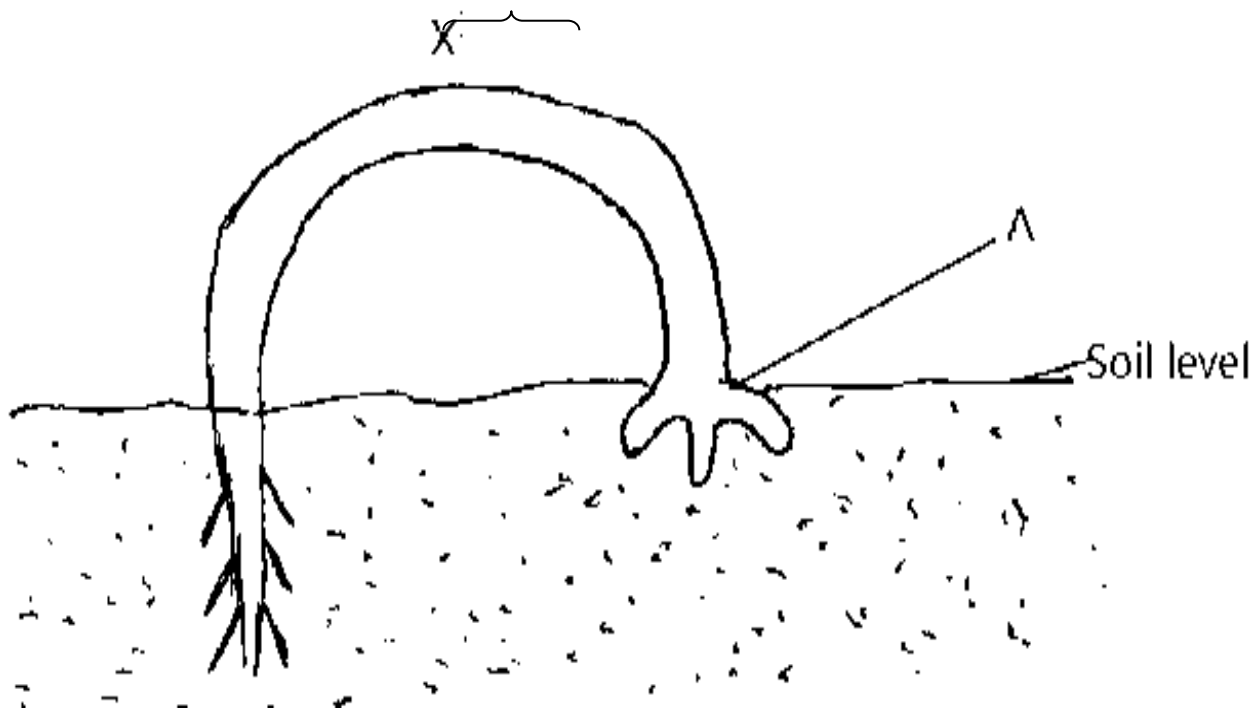

(a) **Name** the type of germination exhibited by the seedling above (1mk)

.....

(b) **Name** the region labeled X (1mk)

.....

(c) **Explain** how the part labeled X of the seedling straightens after exposure to sunlight. (3mks)

.....  
.....  
.....

21. A student estimating the cell size of an onion epidermal cell observed the following on the microscope field of view using a transparent ruler.

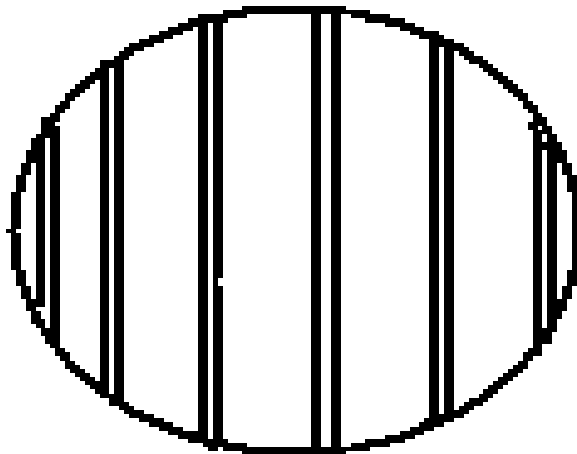

The student counted 20 cells a cross the field of view.

**Calculate** the size of the cell in micrometer. Show the working clearly. **(3mks)**

.....

.....

.....

.....

.....

.....

**22. Name** the components of the blood that do not enter the renal tubule in mammals. **(2mks)**

.....

.....

.....

**23. Give three** reasons as to why biological control is preferred to chemical control in the control of pests and parasites. **(3mks)**

.....

.....

.....

**24. A person** fell from the third floor of a storey building and had part of his brain damaged.

**Indicate** the part of the brain damaged if the person suffers from the following.

(i) Loss of memory and speech **(1mk)**

.....

.....



**(ii)** Inability to regulate body temperature **(1mk)**

.....  
.....

**(iii)** Irregular heartbeat and breathing **(1mk)**

.....  
.....

**(iv)** Inability to maintain proper body balance and posture **(1mk)**

.....  
.....

**25. (a)** Name the microorganism found in the root nodules of legumes **(1mk)**

.....  
.....

**(b)** State the association of the micro-organisms named in (a) above **(1mk)**

.....  
.....  
.....



(c) **What** is the role of the microorganism you named in (a) above. **(1mk)**

.....

.....

.....

**26.** Name the causative agent of cholera **(1mk)**

.....

.....

**27.** State **two** ways in which the composition of blood in the umbilical artery differ from that in umbilical vein. **(2mks)**

.....

.....

.....

**28.** State **three** ways in which the tracheole system is adapted to its function. **(3mks)**

.....

.....

.....

.....

.....



**29. Give a reason for each of the following.**

**(a)** Long feathery stigma in a flower

**(1mk)**

.....  
.....  
.....

**(b)** Presence of nectaries in some flowers

**(1mk)**

.....  
.....  
.....

**30. For a leaf to be efficient for photosynthesis, it has to be broad and thin. Explain.**

**(2mks)**

.....  
.....  
.....  
.....  
.....  
.....





# KCSE 2021 PREDICTION

NAME.....

INDEX NO.....

SCHOOL.....

SIGN.....

DATE.....

231/2

## BIOLOGY

(THEORY)

PAPER 2

TIME: 2 HOURS

### Instructions to candidates

1. Write your **name**, **index number** and the **name** of your school in the spaces provided above.
2. **Sign** and write the **date** of examination in the spaces provided above.
3. Answer **all** questions in this question paper.
4. Answers to **all** questions **must** be written in the spaces provided in this booklet.

### For Examiner's Use Only

SECTION	QUESTION	MAX.SCORE	CANDIDATES SCORE
A			
B	6	20	
	7	20	
	8	20	
TOTAL		80	



**SECTION A (40MKS)**

**Answer ALL the questions in this section in the spaces provided.**

1. (a) Define

i) Osmosis

(1mk)

.....  
.....  
.....

ii) Haemolysis

(1mk)

.....  
.....  
.....

(b) State the role of active transport in plants.

(2mks)

.....  
.....  
.....

(c) Why is oxygen important in the process of active transport?

(1mk)

.....  
.....  
.....

(d) State three properties of the cell membrane

(3mks)

.....



.....  
.....  
.....

2. The diagram below represents a food web in a terrestrial ecosystem.

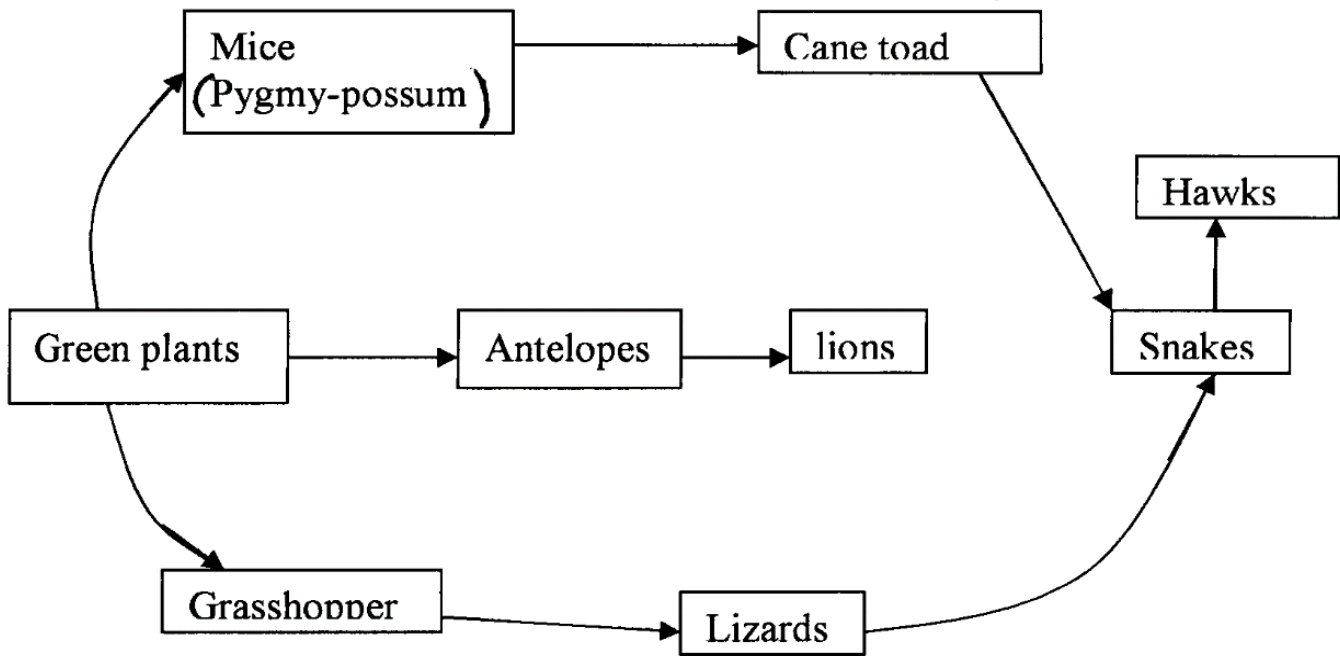

(a) Which organism has the fewest number of preys (1mk)

.....  
.....

(b) Construct food chains with snakes as tertiary consumers (2mks)

.....  
.....  
.....  
.....



(c) State the trophic level occupied by hawks in the food chains constructed in b) above **(1mk)**

.....

.....

.....

(d) Describe how capture — recapture method can be used in estimating the population of fishes in a lake. **(4mks)**

.....

.....

.....

.....

.....

.....

.....

.....

3. (a) Differentiate between the mode of fertilization in higher plants and in mammals. **(2mks)**

.....

.....

.....

.....

.....



(b) Explain the role of the following hormones in the female menstrual cycle

(i) Oestrogen (2mks)

.....  
.....  
.....

(ii) Luternizing hormone (2mks)

.....  
.....  
.....

(c) Give two functions of the placenta during pregnancy (2mks)

.....  
.....  
.....

4. The diagram below shows a set up that was used to demonstrate fermentation.

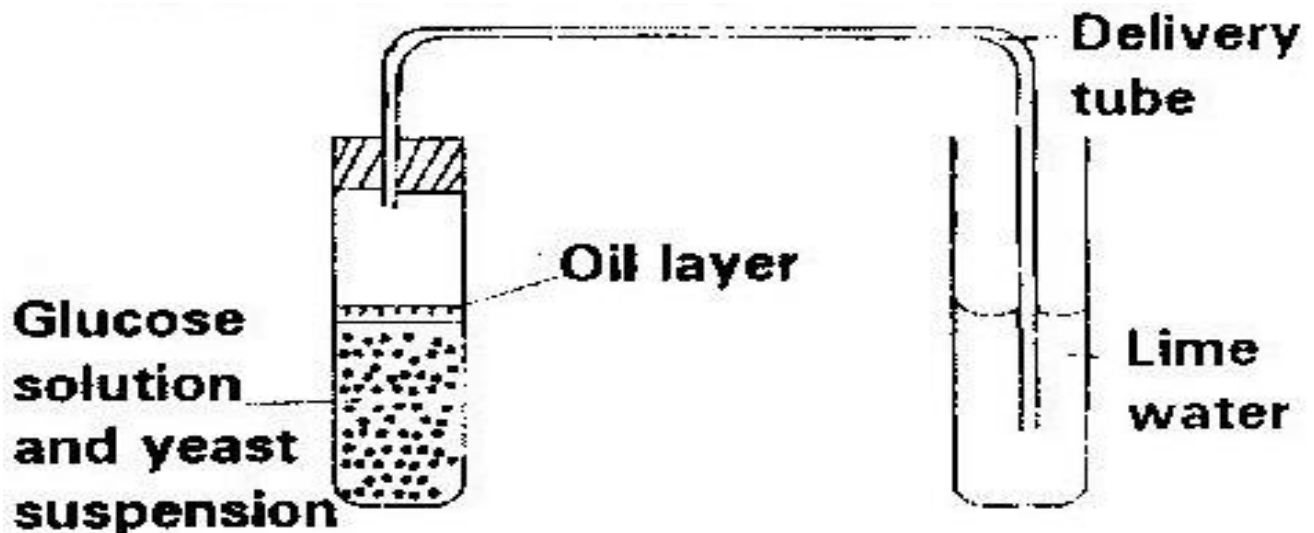

Glucose solution was boiled and oil added on top of it. The glucose solution was then allowed to cool before adding the yeast suspension.

**a)** Why was the glucose solution boiled before adding the yeast suspension? **(1mk)**

.....  
.....  
.....

**b)** What was the importance of cooling the glucose solution before adding the yeast suspension? **(1mk)**

.....  
.....

**c)** What was the use of the oil in the experiment? **(1mk)**

.....  
.....

**d)** What observation would be made in test tube B at the end of the experiment **(1mk)**

.....  
.....

**e)** Suggest a control for this experiment **(1mk)**

.....  
.....



5. Hemophilia or bleeder's disease is a condition in which blood takes a longer time than usual to clot. This is due to lack of a certain blood protein. The gene for hemophilia is recessive to the gene for normal clotting factor and is found on the X-chromosome.

(a) Explain why there are only female carriers for hemophilia and no male carriers for traits.

**(1mark)**

.....

.....

.....

.....

(b) A carrier female for hemophilia trait married a normal male. Work out the possible genotype of the children. Let letter **H** represent the normal gene, and let h represents the gene for hemophilia. **(4marks)**

.....

.....

.....

.....

.....

.....

.....



c. Identify the types of chromosome mutations I, II and IV. (3mks)

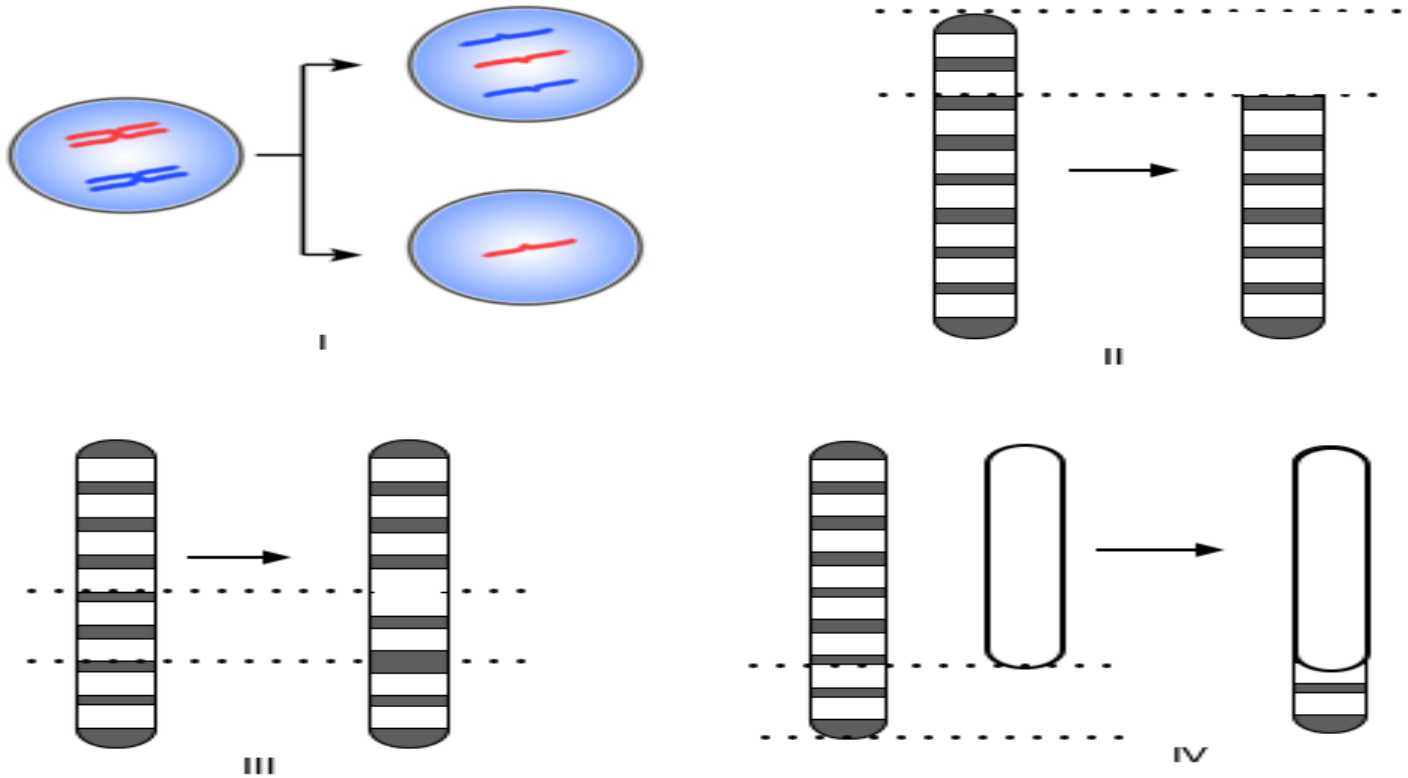

I .....

II .....

IV .....

### SECTION B

Answer question 6 (Compulsory) and either question 7 or 8

6. Two sets of a pea seeds were germinated, set A was placed in normal daylight conditions in the laboratory while set B was placed in a dark cupboard. Starting a few days later the shoots

Time in hours	0	12	24	36	48	60	72	84
Set A length (mm)	12	14	20	23	28	31	47	54
Set B length (mm)	17	23	28	35	48	62	80	94

lengths were measured twice daily and their mean lengths recorded as shown in the table below.



(a) Using suitable scale draw the graphs of the mean lengths in set A and B against time. (8 mks)

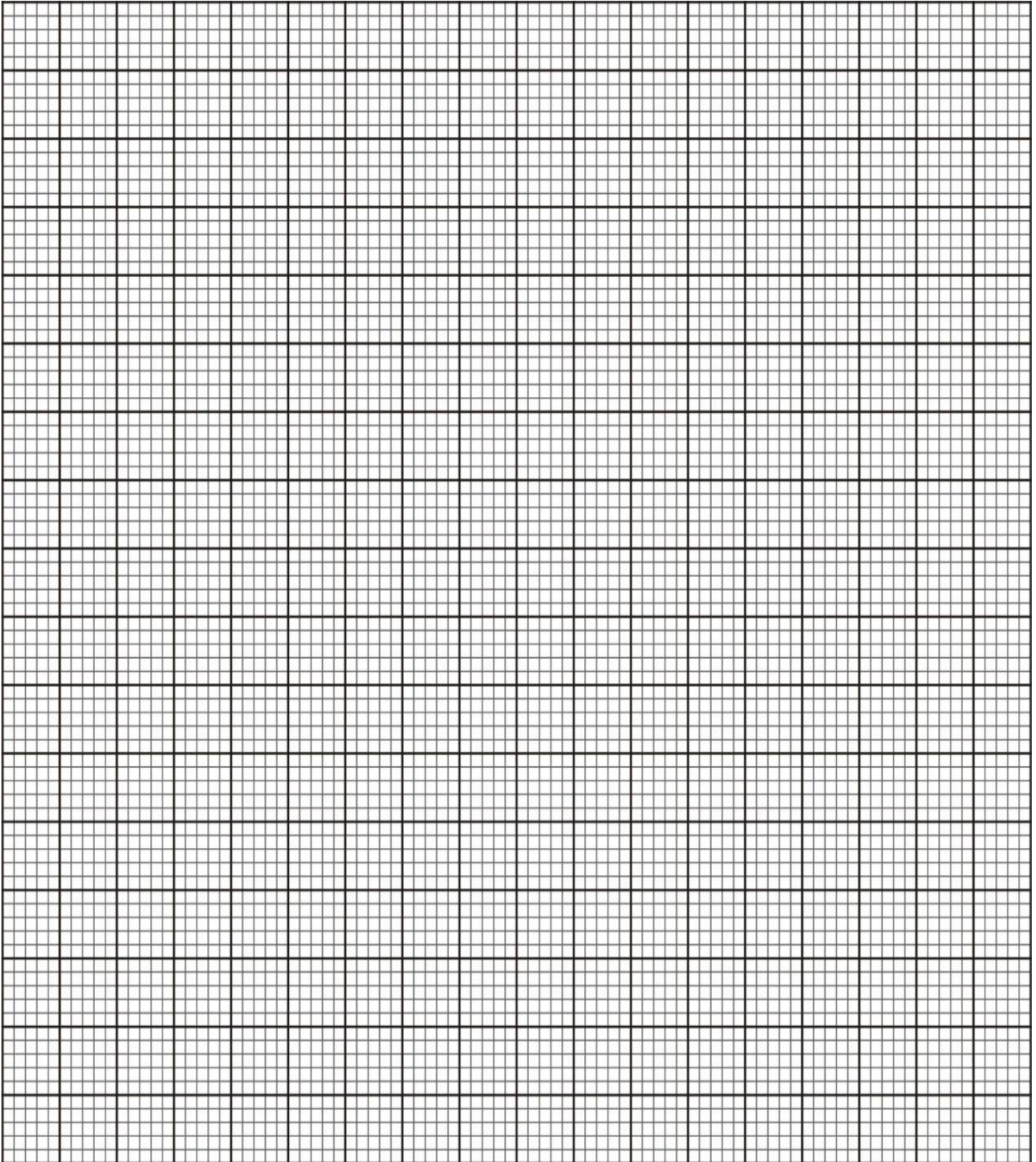

**(b)** From the graph state the mean shoot length of each set of seedling at the 66<sup>th</sup> hour **(2mks)**

.....

.....

.....

.....

**(c)** Account for the difference of curve B and A **(3 mks)**

.....

.....

.....

.....

**(d)** Explain what would happen to set up B if it were allowed to continue to grow under conditions of darkness **(4mks)**

.....

.....

.....

.....

**(e)** State three external conditions which should be constant for both set ups **(3mks)**

.....

.....

.....

.....



7. (a). How are xerophytes adapted to their habitat? (10mks)

(b). Discuss application of genetics in health care today. (10mks)

8. Outline and explain the various functions of the liver in mammals. (20mks)

.....

.....

.....

.....

.....

.....

.....

.....

.....

.....

.....

.....

.....

.....

.....

.....

.....

.....

.....

.....

.....

.....

.....

.....

.....

.....

.....

.....

.....

.....

.....







# KCSE 2021 PREDICTION

NAME..... INDEX NO.....

SCHOOL..... SIGN.....

DATE.....

231/3

## BIOLOGY

(PRACTICAL)

PAPER 3

TIME: 1 $\frac{3}{4}$  HOURS

### Instructions to candidates

- (a) Write your **name**, **index number** and the **name** of your school in the spaces provided above.
- (b) **Sign** and **write the date** of examination in the spaces provided above.
- (c) Answer **all** questions in this question paper.
- (d) Answers to **all** questions **must** be written in the spaces provided in this booklet.

### For Examiner's Use Only

QUESTION	MAXIMUM SCORE	CANDIDATES SCORE
1	12	
2	13	
3	15	
<b>TOTAL</b>	<b>40</b>	



1. You are provided with liquid **X** and substance **Q**

- (a) Place three drops of liquid **X** onto a white tile. Add four drops of iodine solution and record your observation. **(1mk)**

.....

.....

.....

.....

- (b) Pour 2ml of liquid **X** into a test-tube. Add equal amounts of Benedict’s solution boil the mixture. Record your observation **(1mk)**

.....

.....

.....

.....

- (c) Label three boiling tubes as set-ups **A**, **B**, and **C**. Place 3ml of liquid **X** into each of the set-ups.

Divide substance **Q** into three equal portions.

To set-up **A**, add one portion of substance **Q** and shake.

• Place the second portion of substance **Q** into a test tube. Add 1ml of water to it and boil for four minutes. Add it to set-up **B** and shake.

• To set —up **C**, add the third portion of substance **Q**. Add 8 drops of 2M hydrochloric acid and shake.

Place the three set-ups in a warm water bath maintained at 37°C for 30minutes.

Cool the set-ups by dipping the boiling tubes in cold water



Place 2ml of the contents of each set-up into three separate test tubes. Add equal amount of Benedict's solution to each of the three test-tubes and boil.

Record your observations **(3mks)**

Set-up A

.....

.....

.....

.....

Set-up B

.....

.....

.....

.....

Set-up C

.....

.....

.....

.....

**(d)** Account for your observations in the set-up **(3mks)**

Set-up A

.....

.....





.....  
Set-up B

.....  
Set-up C

.....  
(e) Give the most likely identity of substance Q (1mk)

.....  
(f) Why was the water bath maintained at 37°C (1mk)

.....  
(g) What is the fate of the product of set up A in an organism? (2mks)



2. Below are photographs of a variety of invertebrates. Examine them and answer the questions that follow.

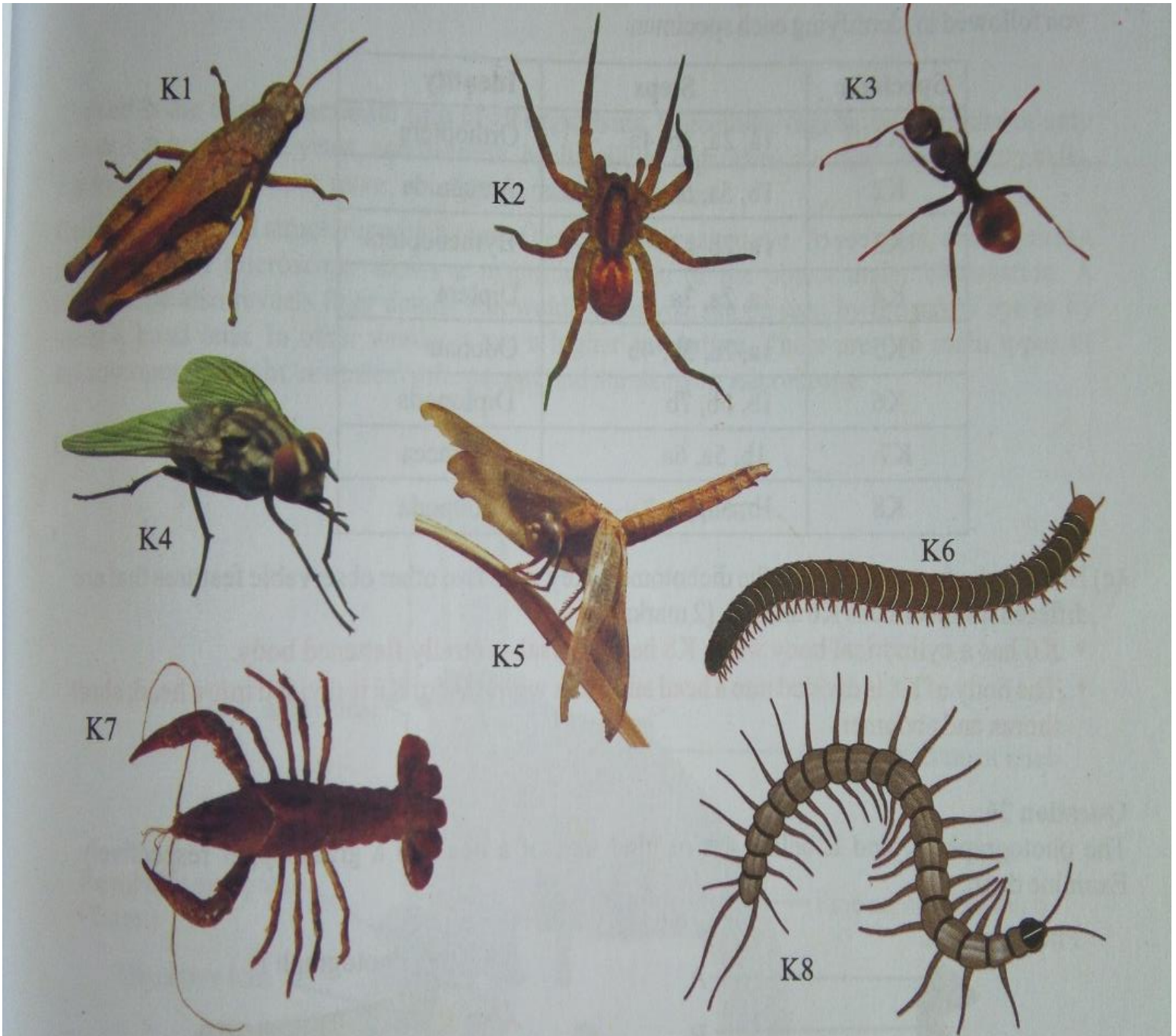

a. Complete the dichotomous key given below. (5mks)

1a. Animal with three pairs of legs.....go to 2

b. \_\_\_\_\_go to 5

2a. Animal with wings.....go to 3

- b. Animal without wings.....Hymenoptera
- 3a. Animal with one pair of wings.....Diptera
- b. \_\_\_\_\_go to 4
- 4a. Fore wings hard.....Orthoptera
- b. Fore wings membranous.....Odonata
- 5a. \_\_\_\_\_go to 6
- b. Animal with more than four pairs of walking legs.....go to 7
- 6a. \_\_\_\_\_Crustacea
- b. Animal without antennae.....Arachnida
- 7a. \_\_\_\_\_Chilopoda
- b. Animal with two pairs of legs in each body segment .....Diplopoda

**b. Use the dichotomous key to identify the specimen in the photographs above. (8mks)**

<b>Specimen</b>	<b>Steps followed</b>	<b>Identity</b>
K1		
K2		
K3		
K4		
K5		
K6		
K7		
K8		



3. All members of plant division Spermatophyta exhibit alternation of generation. The photographs below show stages in the growth and development of a spermatophyte.

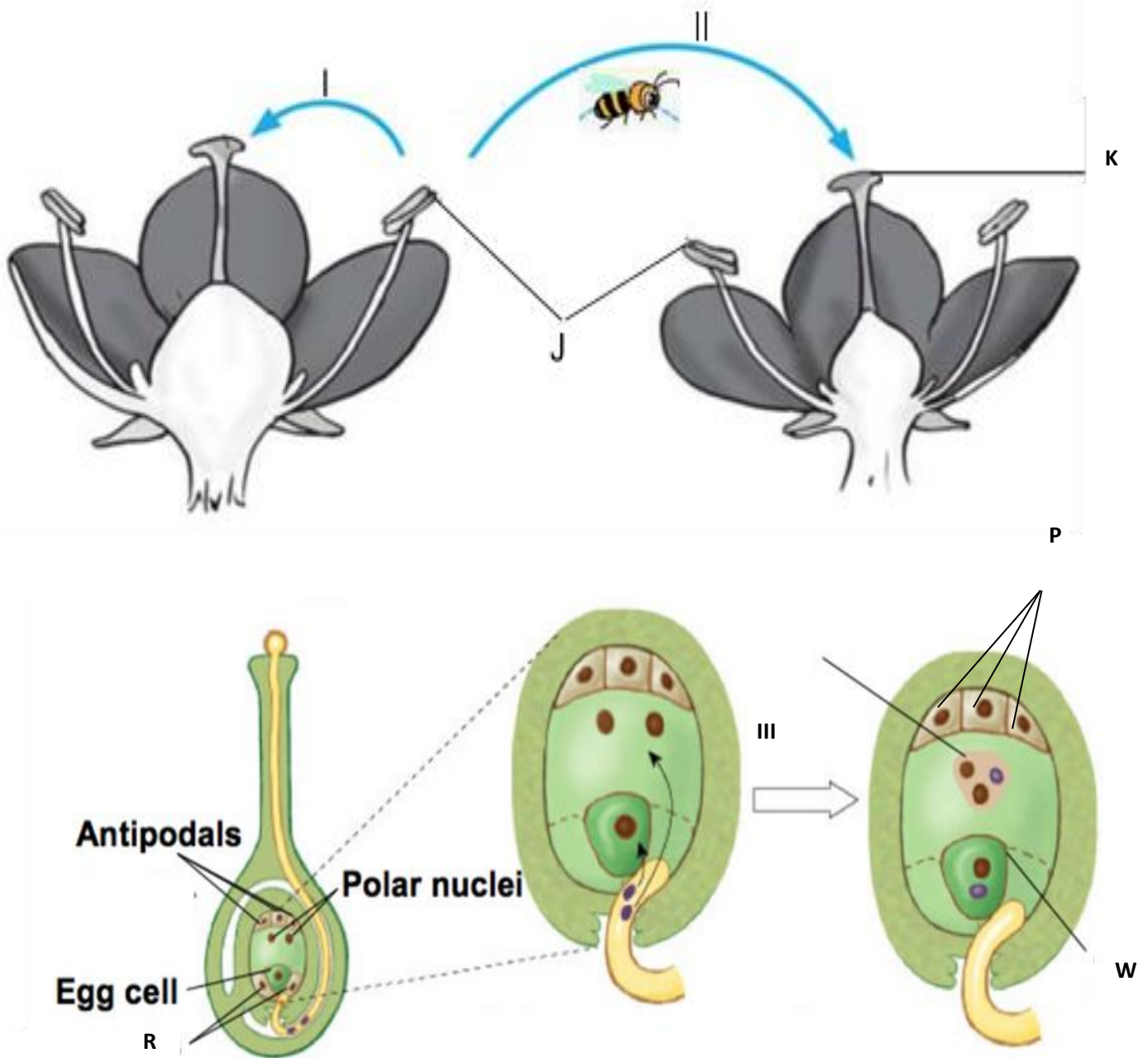

**a. i. Processes I, II and III.**

**(3mks)**

**I**

**II**

**III**

**ii. Structures K, P, R and W.**

**(4mks)**

**K**

**P**

**R**

**W**

**iii. The cell division process that occurs in structures J.**

**(1mk)**

.....  
.....

**iv. The products of the process named in (iii) above.**

**(1mk)**

.....  
.....

**b. Explain the role of the following in promoting process II in the flowering plants.**

**i. Petals**

**(2mks)**

.....  
.....



**ii.** Filaments.

**(2mks)**

.....

.....

.....

.....

**c.** The photographs above represents one of the phases in alternation of generations in spermatophytes. Name the phase.

**(1mk)**

.....

.....



# KCSE 2021 PREDICTION

NAME.....

INDEX NO.....

SCHOOL.....

SIGN.....

DATE.....

233/1

## CHEMISTRY

Paper 1

2 HOURS

### Instructions to candidates

- (a) Write your *name*, *index number* and the *name* of your school in the spaces provided above.
- (b) Sign and write the *date* of examination in the spaces provided above.
- (c) Answer *all* questions in this question paper.
- (d) Answers to *all* questions *must* be written in the spaces provided in this booklet.
- (e) This paper consists of Two Sections **A** and **B** in the spaces provided.
- (f) All working **MUST** be clearly shown.
- (g) Electronic calculators and mathematical tables may be used.
- (h) KNEC mathematical tables and non-programmable silent electronic calculators *may* be used.
- (i) Candidates should check to ascertain that all pages are printed as indicated and that no questions are missing.

### For Examiner's Use Only

Question	Maximum score	Candidate's score
1-27	80	



**1. State three differences between physical and chemical changes (3 Mark)**

Physical changes	Chemical changes

**2. Use the information in the table below to answer the question that follow.(the letters do not represent the actual symbols of the elements**

Element	B	C	D	E	F
Atomic number	18	5	3	5	20
Mass number	40	10	7	11	40

Which two letters represent the same element? Give a reason **(1 Mark)**

.....  
 .....  
 .....

The table below shows the mass numbers and percentage abundances of isotopes W<sub>1</sub> and W<sub>2</sub> of element W

Isotope	Mass numbers	% Abundance
W <sub>1</sub>	12	98.3
W <sub>2</sub>	14	1.7

Determine the relative atomic mass of element W **(2 Marks)**

.....  
 .....





.....  
.....  
.....  
.....

3. When carbon (IV) oxide gas was passed through aqueous calcium hydroxide a white suspension was formed.

a) Write an equation for the reaction that took place (1 Mark).

.....  
.....  
.....

b) State and explain the observations that would occur when excess carbon (IV) oxide is bubbled through the white suspension (2 Marks)

.....  
.....  
.....  
.....  
.....

4. The reaction below takes place on the haber process in the production of ammonia

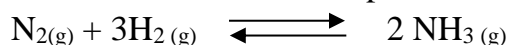

a) How the yield of ammonia would be affected if the pressure is increased. Give a reason(2 mks)

.....  
.....



.....  
.....

b) The forward reaction was found to be favored by decrease in temperature. What is the sign of  $\Delta H$  on the above reaction (1 mark)

5. Describe how you would separate a mixture of iron fillings, iron (iii) chloride and sodium chloride (3 marks)

.....  
.....  
.....  
.....

6. The pH values of solutions K,L,M,N and Pare as shown below

Solution	K	L	M	N	P
pH value	5	2	7	12	9

a) Which of the solution is likely to be

i. Soap solution (1/2 mk)

.....  
.....

ii. Sodium chloride (1/2 mk)

.....  
.....

b) Zinc oxide was found to react with both solutions L and N. What property of zinc oxide was displayed y these reactions (1 mark)

.....  
.....  
.....



7. (a) State Boyles law of gases

(1 mark)

.....  
.....  
.....  
.....

(b) In a class experiment, it was found that a gas occupied  $48\text{dm}^3$  at  $25^{\circ}\text{C}$  and 2 atmospheres pressure.  
What volume would it occupy at STP (2 marks)

.....  
.....  
.....  
.....  
.....  
.....  
.....  
.....



8. The set up below was used to prepare oxygen gas. Study it and answer the questions that follow



a) Complete the diagram to show how oxygen gas is collected (2 marks)

b) Identify X ( $\frac{1}{2}$  mark)

c) .....

.....

d) Name two other reagents which can be reacted to produce oxygen gas in the laboratory ( $\frac{1}{2}$  mark)

.....

.....

.....

.....

9. Name the process which takes place when

i. Iodine changes directly from solid to gas (1 mark)

.....

.....

**ii.**  $\text{Fe}^{2+}_{(\text{aq})}$  changes to  $\text{Fe}^{3+}_{(\text{aq})}$  **(1 mark)**

.....  
.....

**iii.** White sugar changes to black when mixed with concentrated sulphuric (VI) acid **(1 mark)**

.....  
.....

**10.** 12.0cm<sup>3</sup> of 0.05 M hydrochloric acid reacted with calcium hydrogen carbonate to form calcium chloride, water and carbon (IV) oxide.

**a)** Write the chemical equation for the reaction **(1 mark)**

.....  
.....

**b)** Calculate the number of moles of hydrochloric acid used **(1 mark)**

.....  
.....

**c)** Determine the number of moles of calcium hydrogen carbonate used **(1 mark)**

.....  
.....  
.....  
.....



**11.**In the last stage of the solvay process, a mixture of sodium hydrogen carbonate and ammonium chloride is formed

**a)** State the method of separation used **(1 mark)**

.....  
.....

**b)** Write an equation showing how lime is slaked **(1 mark)**

.....  
.....

**c)** Name the by- product recycled in the above process **( 1 mark)**

.....  
.....

**12.**An alkanol has the following composition by mass: Hydrogen 13.5%, Oxygen 21.6% and carbon 64.9%

**a)** Determine the empirical formula of the alkanol (C = 12.0, H= 1.0, O= 16.0 ) **(2 marks)**

.....  
.....  
.....  
.....



- b) Given that the empirical formula and molecular formula are the same, draw the open structure of the alkanol (1 mark)

13. The graph below shows how electrical conductivity of metals varies with temperature

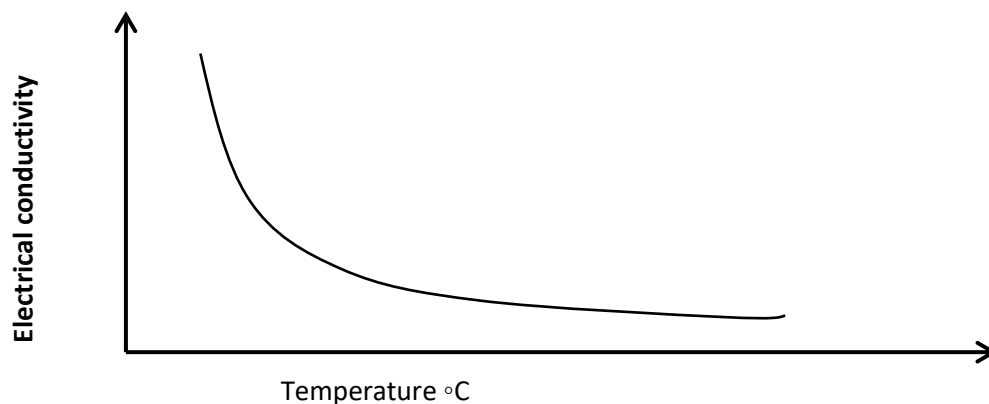

- a) Explain the variation of electrical conductivity with temperature (2 marks)

b) State the particle responsible for conductivity in

- i. Molten lead (ii) bromide (1/2 mk)

.....  
.....

- ii. Graphite (1/2 mk)

.....  
.....



14. Study the scheme and answer the questions

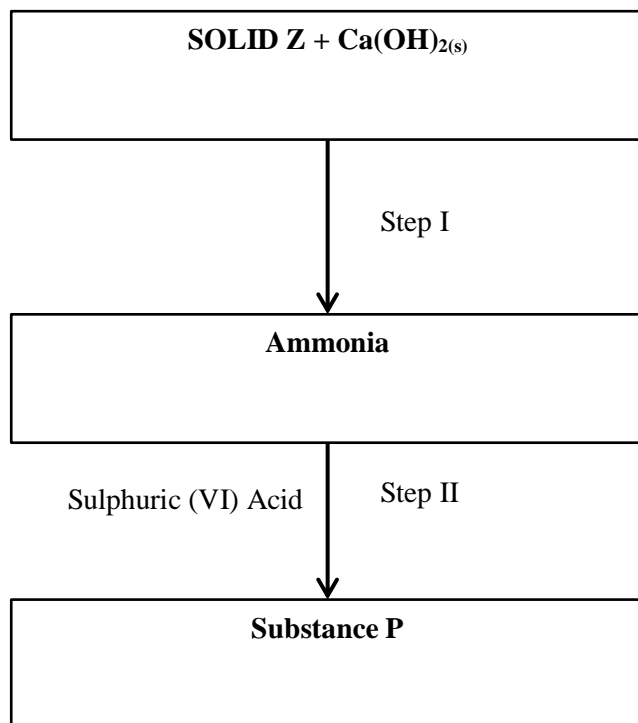

Identify ;

i. Solid Z (1 mk)

.....  
.....

ii. Substance P (1 mk)

.....  
.....

Give one use of substance P (1 mark)

15. The diagram below is a section of a model of the structure of element K





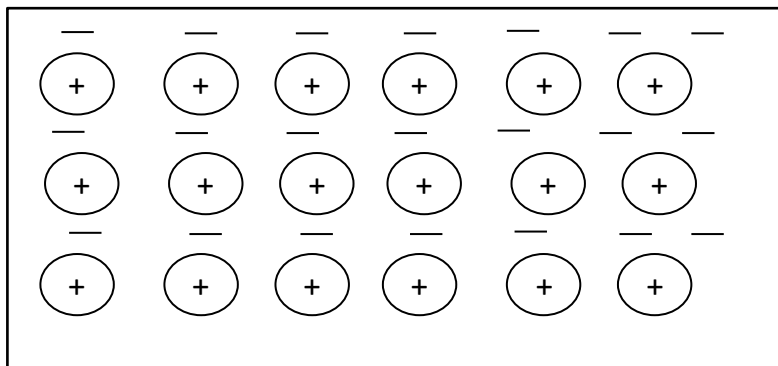

Key  
⊕ charged nucleus  
— electron

a) State the type of bonding that exist in K

.....

.....

b) In which group of the periodic table does element K belong. Give a reason (2 marks)

.....

.....

.....

.....

16. Study the diagram below and answer the questions that follow

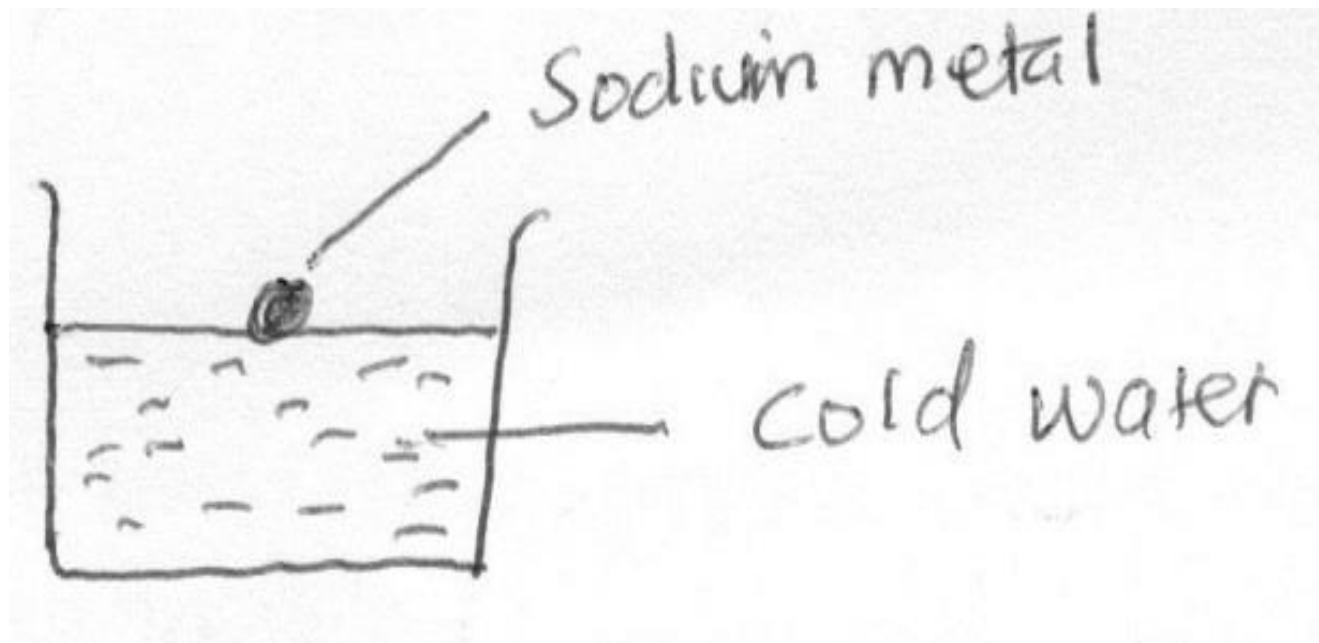

a) State two observations made in the above experiment when sodium react with water (2 marks)

.....

.....

.....

.....

b) Write a chemical equation for the reaction that takes place (1 mark)

.....

.....

17. Study the nuclear reactions below

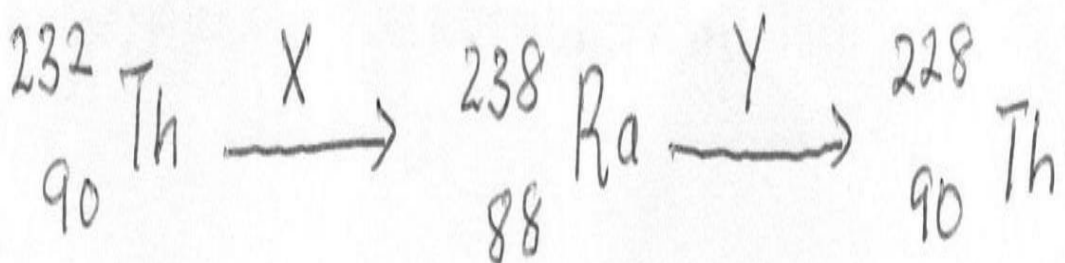

a) Identify emissions X and Y

(1 mk)

X.....

Y.....

b) 100g of radioactive substance reduced to 6.25g in 8 years. Calculate the half life of radioactive substance

(2 marks)

.....  
 .....  
 .....  
 .....

18. Describe how a solid sample of lead (ii) chloride can be prepared using the following reagents: dilute nitric (v) acid, dilute hydrochloric acid, and lead (ii) carbonate powder

(3 marks)

.....  
 .....  
 .....  
 .....



.....  
.....

19. (a) Explain why permanent hardness in water cannot be removed by boiling (2 marks)

.....  
.....  
.....  
.....

(b) Name two methods that can be used to remove permanent hardness from water (1 mark)

.....  
.....  
.....  
.....

20. The diagram below shows the Frasch process used for extraction of sulphur. Use it to answer the questions that follow

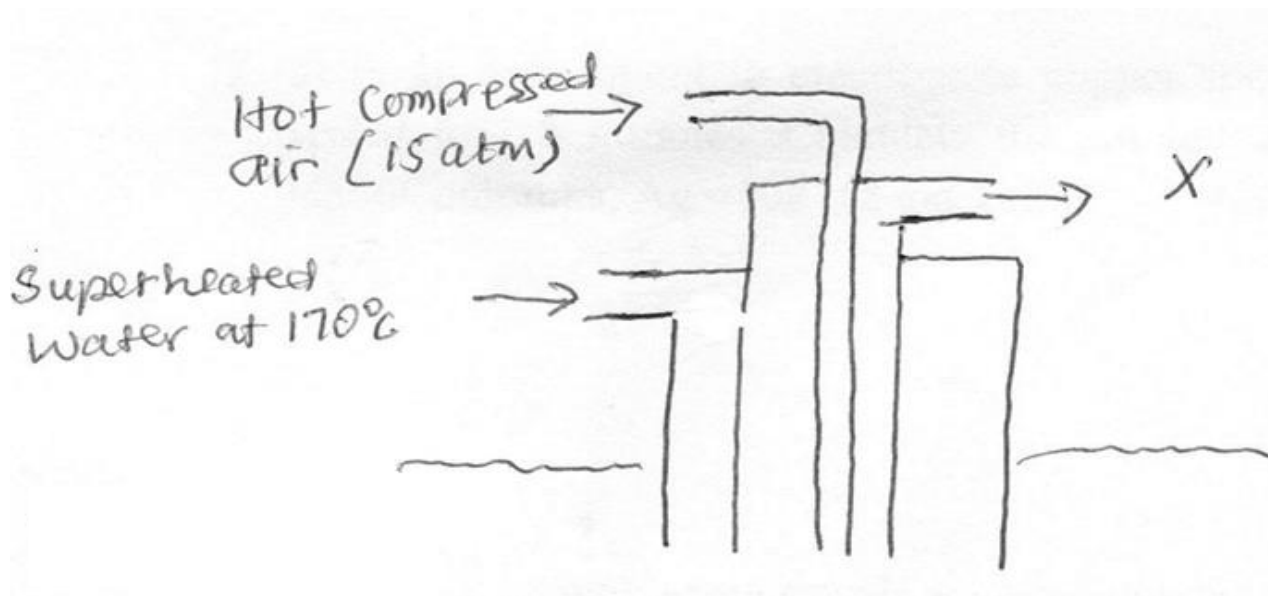

i. Identify X (1 mark)

.....  
.....



ii. Why is it necessary to use super heated water in this process (1 Mark)

.....  
 .....

iii. State one physical property of sulphur that make it possible for it to be extracted by this method (1 mark)

.....  
 .....

21. Study the scheme below and answer the questions that follow

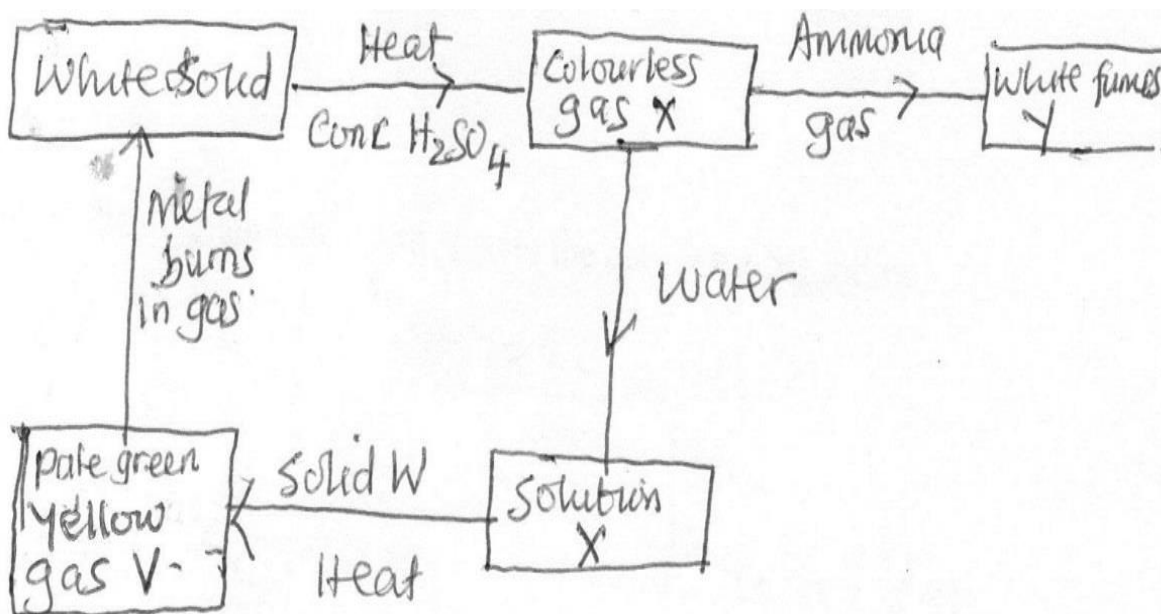

a) Write an equation for the formation of white fumes Y (1 mark)

.....  
 .....

b) What is the function of solid W in the reaction (1 mark)

.....  
 .....



c) Identify gas V

**(1 mark)**

.....  
.....

**22.(a)** In an experiment to electroplate copper spoon with silver, a current of 0.5 A was passed for 18 minutes .Calculate the amount of silver deposited on the spoon.(1F = 96500Coulombs, Ag =108)

**(2 marks).**

**(b)** Give a reason why some metals are electroplated

**(1 mark)**

.....  
.....

**23.(a)** Define isomerism

**(1 mark)**

.....  
.....  
.....  
.....

**(b)** Draw and name two isomers of a compound with molecular formula C<sub>3</sub>H<sub>7</sub>OH

**(2 marks)**



24. Study the diagram below and answer the questions that follow

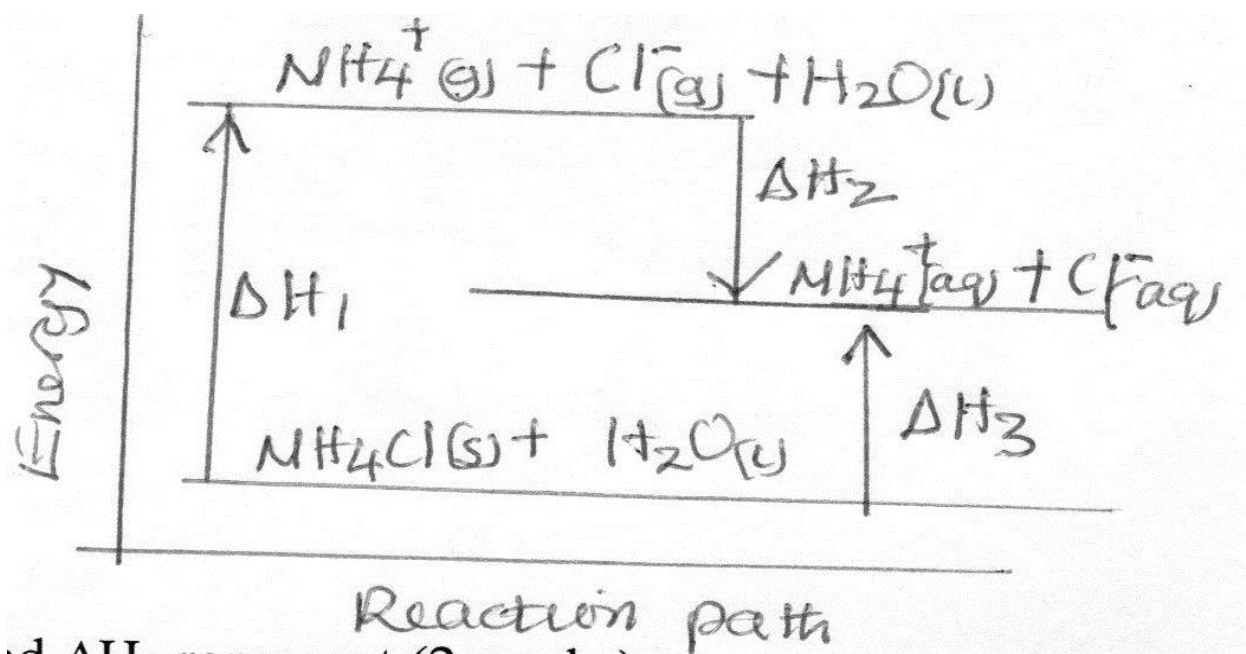

a) What do  $\Delta H_1$  and  $\Delta H_2$  represent

(2 marks)

.....

.....

.....

.....

b) Write an expression to show the relationship between  $\Delta H_1$ ,  $\Delta H_2$  and  $\Delta H_3$

(1 mark)

.....

.....

.....

.....



25. A glass tube was inserted into a flame formed when the air hole of a Bunsen burner was fully open as in the diagram below

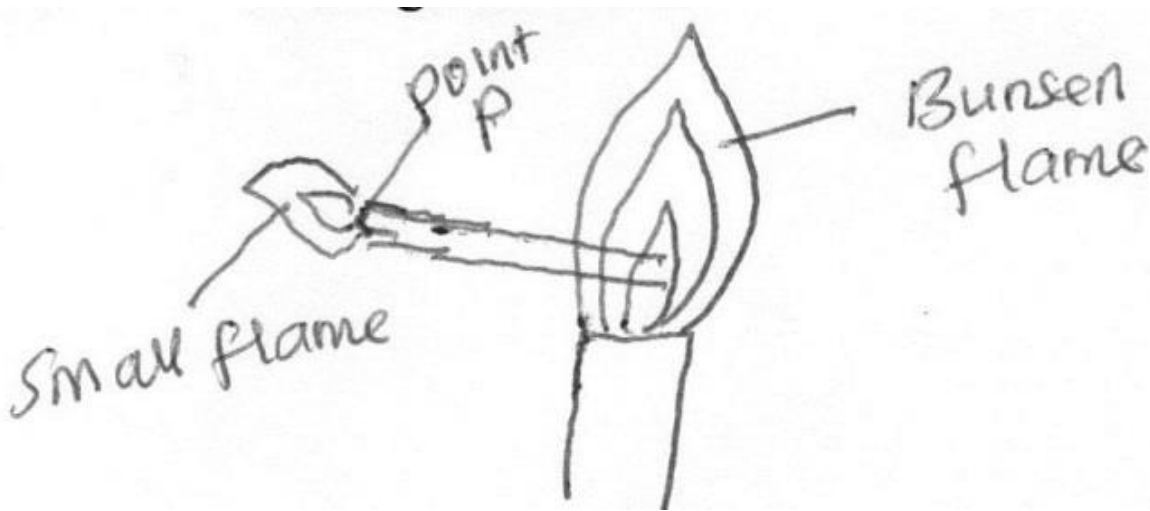

a) When a burning splint was brought near point P, a small flame lit at the end of the glass tube. Explain (1 mark)

.....

.....

.....

.....

b) Give two reasons why the Bunsen burner flame above is preferred for heating than the flame obtained when the Bunsen burner air hole is closed. (2 marks)

.....

.....

.....

.....



**26.(a)** Use the information given below to draw diagram of an electrochemical cell that can be constructed to measure the electromotive force between G and J **(2 Marks)**

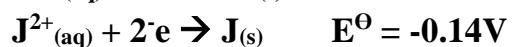

**(b)** Calculate the  $E^{\ominus}$  value for the cell constructed in (a) above

**(1 mark)**

**27.** Use bond energy value given below to answer the question that follow

Bonds	Bond energy kJ/ mole
H-H	432
C=C	610
C-C	346
C-H	413

Determine the enthalpy change for conversion of ethene to ethane by hydrogenation as shown in the equation below **(3 marks)**



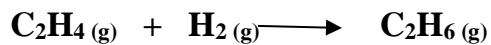

.....

.....

.....

.....

.....

.....

.....

.....

.....

.....

.....

.....

.....

.....

.....

.....

.....

.....

.....

.....

.....

.....

.....



# KCSE 2021 PREDICTION

NAME.....

INDEX NO.....

SCHOOL.....

SIGN.....

DATE.....

233/2

## CHEMISTRY

Paper 2

2 HOURS

### Instructions to candidates

- Write your **name**, **index number** and the **name** of your school in the spaces provided above.
- Sign** and **write** the **date** of examination in the spaces provided above.
- Answer **all** questions in this question paper.
- All working **MUST** be clearly shown where necessary.
- KNEC mathematical tables and non-programmable silent electronic calculators **may be** used.
- Candidates should check to ascertain that all pages are printed as indicated and that no questions are missing.

### For Examiner's Use Only

Question	Maximum score	Candidate's score
1	10	
2	11	
3	12	
4	10	
5	14	
6	10	
7	13	
<b>Total</b>	<b>80</b>	



1. In an experiment of diluting concentrated sulphuric (vi) acid, 2 cm<sup>3</sup> of acid were carefully poured into a plastic cup containing exactly 40cm<sup>3</sup> of distilled water with a room temperature of 20<sup>0</sup>c. the mixture was stirred with a thermometer; the highest temperature noted was 35<sup>0</sup>c. (density of acid = 1.84g/cm<sup>3</sup> while that of solution is assumed to be 1g/cm<sup>3</sup>. The acid is 98% pure, S.H.C. =4.2J/g/k H = I S = 32 O = 16)

a). i). Determine the number of moles of the acid that dissolved (2 mks)

.....

.....

.....

.....

.....

ii). Determine the enthalpy change for the reaction. (2mks)

.....

.....

.....

.....

.....

iii). Determine the enthalpy change when one more of the acid is dissolved in water. (2 mks)

.....

.....

.....

.....

.....



b). Use the information below to answer the questions that follow;

<u>Equation</u>	<u>Enthalpy of formation</u>
-----------------	------------------------------



a) Define the term enthalpy of formation of a compound (1mk)

.....

.....

.....

.....

b) Calculate the molar enthalpy of combustion : $\Delta H_3$  of carbon (ii) oxide (3mks)

.....

.....

.....

.....

.....

2. Name the following compounds (3 mks)

a) i).  $CH_3CH_2CH_2OH$

.....

.....

ii).  $CH_3CH_2CH_2COOH$



iii).  $\text{CH}_3\text{CH}_2\text{CH}_2\text{COOCH}_2\text{CH}_3$

b). Study the scheme below and answer the questions that follow

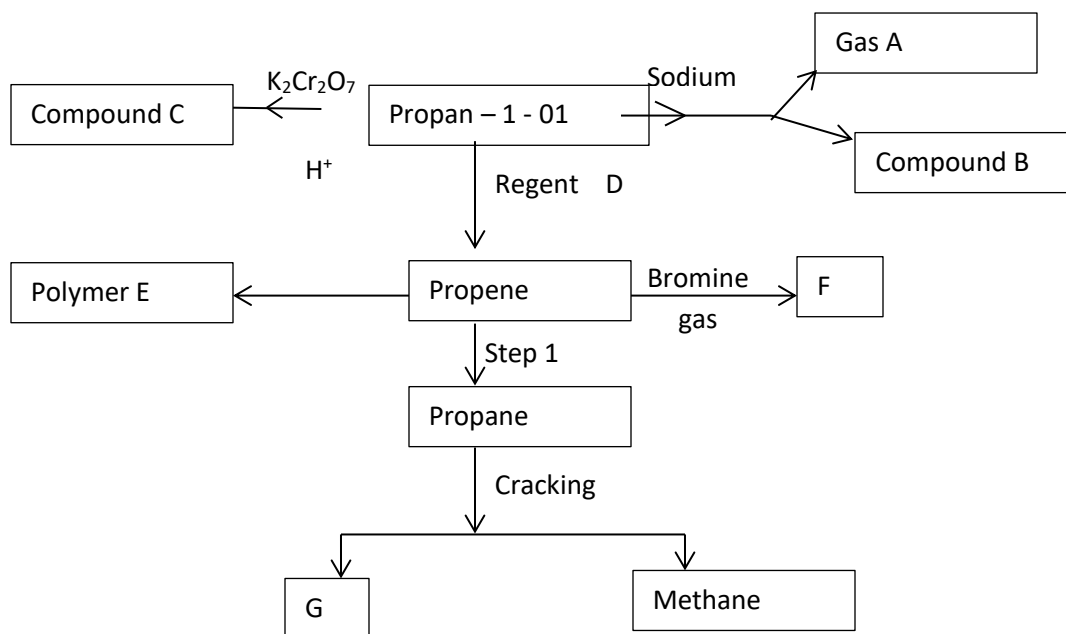

i. Identify product

A

(1 mk)

F

(1 mk)



.....  
.....

**ii.** Name the compound C **(1 mk)**

.....  
.....

**iii.** State the conditions for step 1 **(1 mk)**

.....  
.....

**iv.** Name the process leading to formation of compound C **(1 mk)**

.....  
.....

**v.** Write an equation for the reaction leading to the formation of methane. **(1 mk)**

.....  
.....  
.....

**vi.** Identify reagent D. **(1 mk)**

.....  
.....



vii. Draw the structure of F. (1 mk)

.....

.....

3. The grid below is a section of the periodic table (letters used are not actual symbol) use it to answer questions that follow.

G						A	
			T			J	
S	F		R	Q		B	E
D	L					C	

i. Select the most electro-negative element. (1 mk)

.....

.....

ii. The boiling point of the oxide of Q is much higher than that of the oxide of T. Explain the difference (2 mks)

.....

.....

.....

.....

iii. Identify with a reason the chemical family to which F and L belong. (2 mks)

.....

.....





**iv.** Use dot (.) and cross (x) diagram to show bonding in the compound formed when F reacts with B. **(1 mk)**

**v.** State and explain the nature of chloride of R when it is dissolved in water to form an aqueous solution. **(2 mks)**

.....

.....

.....

.....

**vi.** Compare the atomic radius of elements D and L. **(2 mks)**

.....

.....

.....

.....

.....



vii. The elements S and D belong to group I, which element is more reactive, explain.

(2 mks)

.....

.....

.....

.....

4. The diagram below shows a blast furnace in the extraction of iron from haematite.

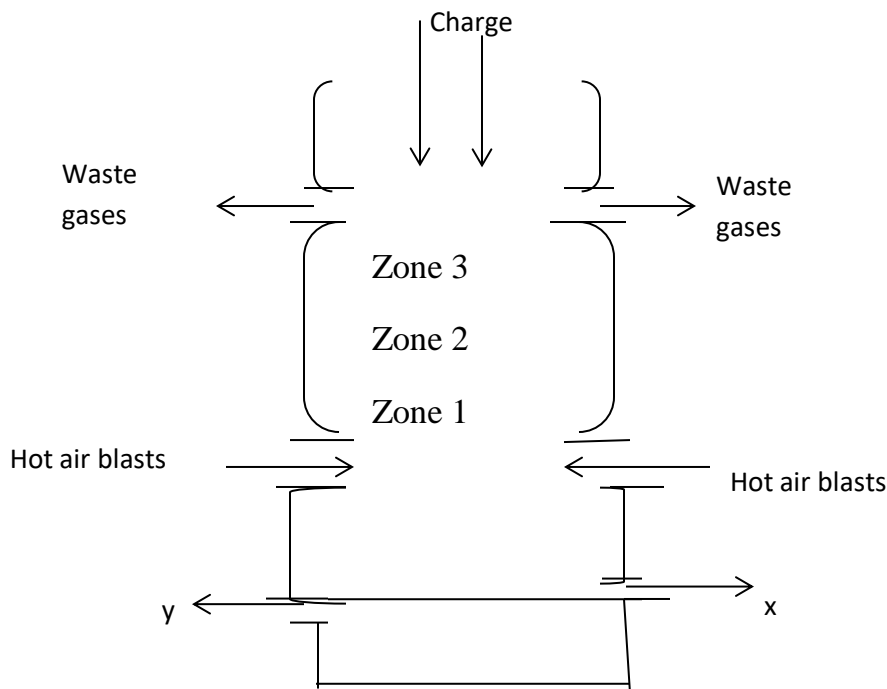

i. Name two other ores that can be used to extract iron.

(2mks)

.....

.....

.....

.....



**ii.** Name the components of the charge (raw materials). **1 mks)**

.....  
.....

**iii.** Identify two components of the waste gases. **(1 mks)**

.....  
.....

**iv.** Give the identity of X and Y. **(2 mks)**

.....  
.....

**v.** Identify two reducing agents in the blast furnace. **(1 mks)**

.....  
.....

**vi.** Write the chemical equation for the reduction of haematite to iron metal using the main reducing agent. **(1 mk)**

.....  
.....

**vii.** Which zone is the hottest? Explain. **(1 mks)**

.....  
.....



5. The flow chart below represents some industrial processes leading to the formation of two nitrogenous fertilizers.

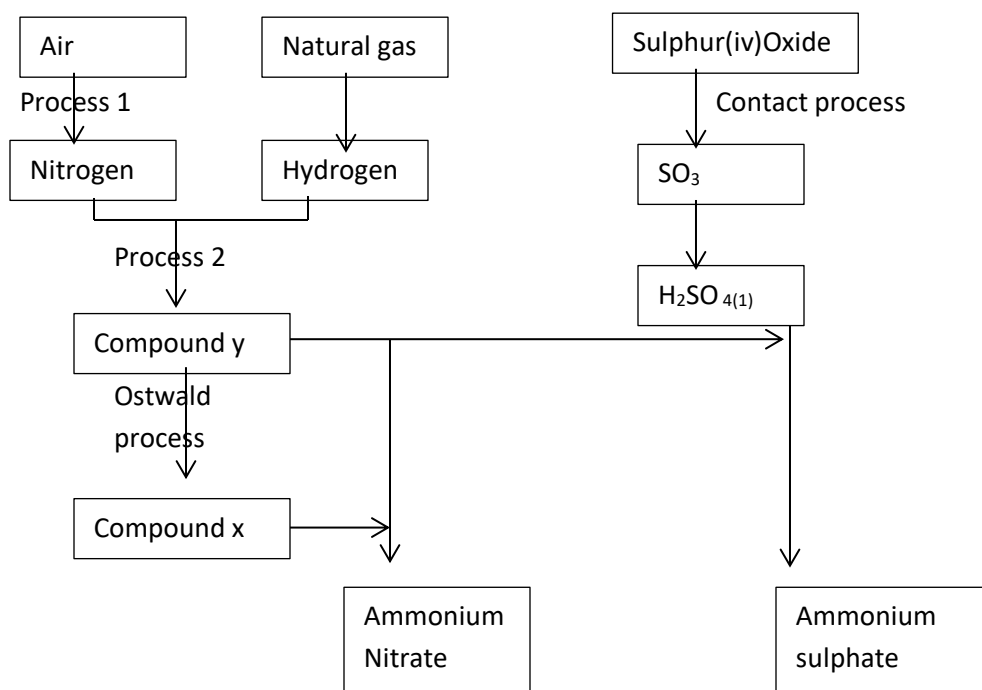

a) Name the catalyst used in (2 mks)

i. Process 2

.....

.....

ii. Ostwald's process

.....

.....

b) Name each of compounds X and Y (1 mk)

X

Y



c) Other than the catalyst named in (b) above, state two optimum conditions for process labeled 2. (1 mk)

.....  
.....

d) Briefly describe process 1 that leads to production of nitrogen from air. (3 mks)

.....  
.....  
.....  
.....  
.....

e) Other than ammonium nitrate being used as a fertilizer name one other use (1 mks)

.....  
.....

f) Ammonium nitrate and ammonium sulphate are used as fertilizers, one would you recommend to a farmer and why? show your working (N=14,O=16,S=32,H=1) (3MKS)

.....  
.....  
.....  
.....  
.....  
.....  
.....



g) Write an equation for the formation of Sulphur( iv) oxide in contact process. (1mk)

.....  
.....

h) Sulphur (iv) oxide is an acid anhydride of sulphuric vi acid, but in contact process Sulphur (iv) oxide is first dissolved in sulphuric (vi) acid. Explain why this is so. (2mks)

.....  
.....  
.....

6. a) The table below gives standard electrode potentials for the metals represented by the letters R, S, T and U. study and answer the questions that follow.

METALS	Standard Electrode Potential (Volts)
R	- 0.34
S	- 0.85
T	+ 0.34
U	- 0.76

i. Identify the metal which is the strongest reducing agent (1 mk)

.....  
.....

ii. Which metal can be displaced from a solution of its salts by all the other metals in the table? Give a reason (2 mks)

.....  
.....



.....  
 .....

b. Metal S and U were connected to form a cell as shown in the diagram below.

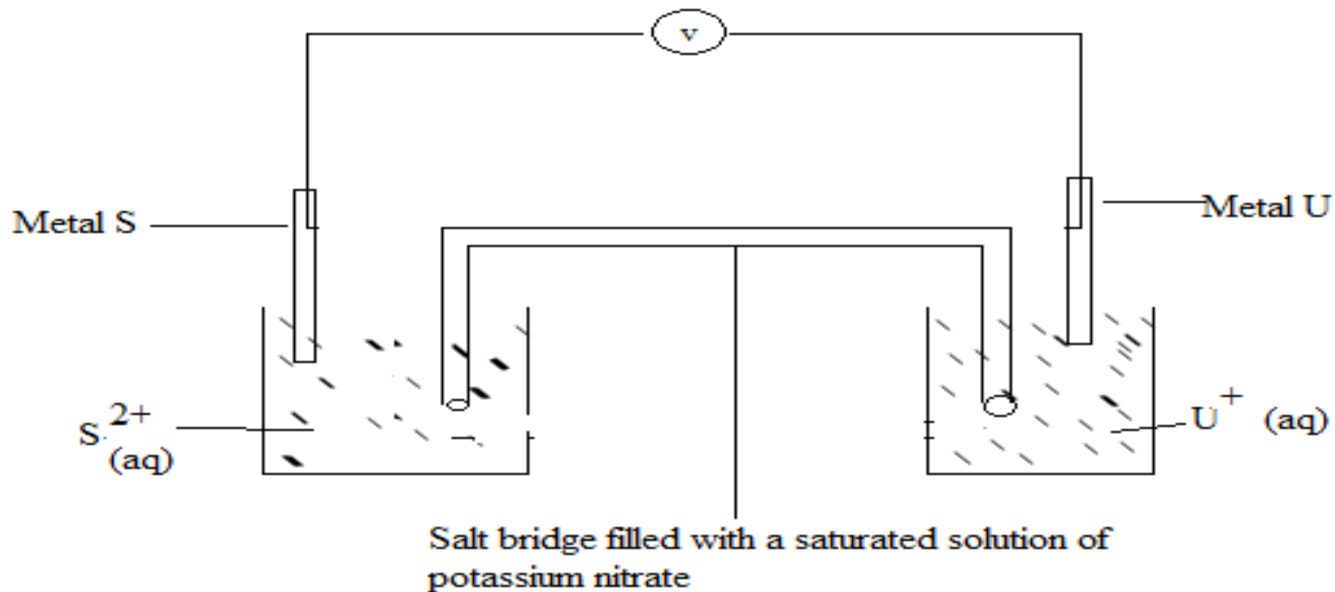

i. Write the equation for the cell above (1 mk)

.....  
 .....

ii. Calculate the e.m.f, for the cell above (1 mk)

.....  
 .....  
 .....  
 .....

iii. On the diagram, indicate with an arrow the direction in which electrons would flow on the diagram above (1 mk)



**iv.** State one function of the salt bridge. **(1 mk)**

.....  
.....

c. In an experiment to electroplate a copper spoon with silver, a current of 0.5 A was passed for 18 minutes.

**i.** Draw a well labeled diagram showing how the copper spoon was electroplated. **(2 mks)**

.....  
.....  
.....  
.....  
.....  
.....  
.....

**ii.** Other than electroplating state one use of electrolysis **(1 mk)**

.....  
.....





7. A group of form four students of Cockelbet Secondary School carried out an experiment to determine the solubility of potassium chlorate. The table below shows the results obtained.

Total volume of water added(cm <sup>3</sup> )	10.0	20.0	30.0	40.0	50.0
Mass of KClO <sub>3</sub> (g)	5.0	5.0	5.0	5.0	5.0
Temperature at which crystals appear(0C)	80.0	65.0	55.0	45.0	30.0
Solubility of KClO <sub>3</sub> (g/100gH <sub>2</sub> O)					

(a) Complete the table to show the solubility of KClO<sub>3</sub> at different temperatures. **(3mks)**

(b) Plot a graph of mass of KClO<sub>3</sub> per 100g water against temperature at which crystals form. **(3mks)**

(c) From the graph, determine ;

(i) The solubility of KClO<sub>3</sub> at 40oC. **(1mk)**

.....

.....

.....

.....

(ii) The temperature at which the solubility of KClO<sub>3</sub> is 35g/100g water. **(1mk)**

.....

.....



.....  
.....  
(d) Explain the shape of the graph. (1mk)

.....  
.....  
.....  
.....

(e) State one application of solubility and solubility curves. (1mk)

.....  
.....  
.....  
.....

f) In an experiment soap solution was added to three separate samples of water. The table below shows the volumes of soap solution required to form lather with 100cm<sup>3</sup> of each sample of water before and after heating/boiling

SAMPLE	A	B	C
Volume of soap before water is boiled in (cm <sup>3</sup> )	30	4	12
Volume of soap after water is boiled in (cm <sup>3</sup> )	30	4	4

I) Which water sample is likely to be soft. Explain (2MKS)

.....  
.....



.....  
.....

**II)** Explain the change in the volume of soap solution used in sample C **(1MK)**

.....  
.....  
.....  
.....



# KCSE 2021 PREDICTION

NAME.....

INDEX NO.....

SCHOOL.....

SIGN.....

DATE.....

233/3

## CHEMISTRY

Paper 3(Practical)

2 ¼ HOURS

### Instructions to candidates

- (a) Write your **name**, **index number** and the **name** of your school in the spaces provided above.
- (b) **Sign** and **write** the **date** of examination in the spaces provided above.
- (c) Answers to **all** questions **must** be written in the spaces provided in this booklet.
- (d) All working **MUST** be clearly shown where necessary.
- (e) You are **NOT allowed** working with the apparatus for the first **15 minutes** of the **2 ¼ hours** allowed for this paper. This time is to enable you read the question paper and make sure you have all the chemicals and apparatus you need.
- (f) KNEC mathematical tables and non-programmable silent electronic calculators **may be** used.

Question	Maximum score	Candidate's score
1	21	
2	13	
3	6	
<b>TOTAL</b>	<b>40</b>	



## QUESTION 1

You are provided with

- ❖ Aqueous sulphuric VI oxide solution A,
- ❖ 0.5 M Sodium Hydroxide solution
- ❖ Magnesium ribbon solid C
- ❖ Phenolphthalein indicator

You are required to determine

- I. The rate of reaction of magnesium ribbon with aqueous sulphuric VI acid solution A
- II. The concentration of sulphuric VI acid in moles per litre

### Procedure 1.

Using a measuring cylinder put 70cm<sup>3</sup> of solution A and place it in a 100 ml beaker. Using a ruler cut off 1cm piece of magnesium ribbon to obtain 8 pieces. Ready with a stop watch, drop 1 piece of magnesium ribbon into the beaker containing the 70cm<sup>3</sup> of solution A and immediately start your stop watch. Note the time taken for all the ribbons to react completely and record it in the table below

Without adjusting the stop watch to zero, drop another 1cm piece of magnesium ribbon immediately to the same mixture and record the time taken for the second ribbon to react completely.

Repeat the experiment until the 8<sup>th</sup> piece of magnesium ribbon is used.

Keep the solution mixture for use in procedure II. Complete the table by computing  $1/\text{time sec}^{-1}$

Length of magnesium ribbon(cm)	1	2	3	4	5	6	7	8
Total time taken in seconds								
Rate of reaction $1/\text{time sec}^{-1}$								

- a) Plot a graph of  $1/\text{time sec}^{-1}$  (Y –axis) against length of magnesium ribbon (cm) used. (3mk)
- b) From the graph determine the time that would be taken if 5.5cm of ribbon to react. (1mk)
- c) Explain how the rate of reaction vary with increase of length of magnesium ribbon 2mks)



**Procedure II**

Place all the solution obtained in procedure I into a clean 250ml volumetric flask. Add distilled water to make 250 cm<sup>3</sup>. Label the resulting solution as D. Fill the burette with solution B. Pipette 25.0 cm of solution D add 3 drops of phenolphthalein indicator and titrate with solution B. Record your results in table II. Repeat the titration two more times.

<b>TITRE</b>	<b>I</b>	<b>II</b>	<b>III</b>
<b>FINAL BURETTE READING (CM<sup>0</sup>)</b>			
<b>INITIAL BURETTE READING (CM<sup>3</sup>)</b>			
<b>VOLUME OF B USED (CM<sup>3</sup>)</b>			

**4MKS**

d) Determine the average volume of B used

**(1MK)**

e) Calculate the number of moles of sodium hydroxide, solution B that was used **(1mk)**

f) Determine

i) The number of moles of Sulphuric VI acid in 25cm<sup>3</sup> of D **(1mk)**

ii) The number of moles of sulphuric VI acid in 250 cm<sup>3</sup> of solution D **(1mk)**

iii) Given that the total number of moles of sulphuric VI acid that reacted with magnesium ribbon was to be 0.08moles. calculate the total number of moles of sulphuric VI acid in 50cm<sup>3</sup> of solution A. **(2mk)**



- iv) Calculate the concentration of the original sulphuric VI acid solution A in moles per liter.  
(1mk)

**QUESTION 2**

2. You are provided with a solid labeled R. carry out the following tests, record the observations and make the correct inferences.

- a) Place solid R In a boiling tube and add about 15cm<sup>3</sup> of distilled water while shaking thoroughly, filter the mixture. Keep the filtrate and residue for the tests below.

Observations	Inferences

(1mk)

(1mk)

- i. To 2cm<sup>3</sup> of the filtrate, add sodium hydroxide until is excess

Observations	Inferences

(1mk)

(1mk)



- ii. To another 2cm<sup>3</sup> portion of the filtrate, dip a clean stirring rod and place it on a non-luminous of a Bunsen burner.

<b>Observations</b>	<b>Inferences</b>

(½mk)

(½mk)

- b) Place the residue in (a) above in a boiling tube. Add dilute nitric (v) acid while shaking until all the solid dissolves. Divide the solution into 3 portions of 2cm<sup>3</sup> each.

<b>Observations</b>	<b>Inferences</b>

(1mk)

(1mk)

- i. To the 1<sup>st</sup> portion, add sodium hydroxide solution till is excess.

<b>Observations</b>	<b>Inferences</b>

(1mk)

(1mk)





- ii. Using potassium iodide (KI), describe a test that you would carry out to find whether  $Pb^{2+}$  ions are present in the second portion in (b) above.

<b>Observations</b>	<b>Inferences</b>

**(1mk)**

**(1mk)**

- iii. Carryout the test described in part (ii) above.

<b>Observations</b>	<b>Inferences</b>

**(1mk)**

**(1mk)**

### **QUESTION 3**

You are provided with liquid Y. Carry out the tests below and write your observations and inferences in the spaces provided.

- (a) To  $1cm^3$  of liquid Y add  $1cm^3$  of water and shake.

<b>Observations</b>	<b>Inferences</b>

**(1mk)**

**(1mk)**



(b) To 1cm<sup>3</sup> of liquid Y in a test tube add 3 drops of universal indicator and determine its PH.

<b>Observations</b>	<b>Inferences</b>

(½mk)

(½mk)

(c) To 2cm<sup>3</sup> of liquid Y add 3 drops of potassium manganate (VII) solution.

<b>Observations</b>	<b>Inferences</b>

(½mk)

(½mk)

(d) To 2cm<sup>3</sup> of liquid Y add 3 drops of bromine water.

<b>Observations</b>	<b>Inferences</b>

(½mk)

(½mk)

(e) To 2cm<sup>3</sup> of liquid add 3 drops of acidified potassium dichromate (vi) and warm.



<b>Observations</b>	<b>Inferences</b>

*(½mk)*

*(½mk)*



# KCSE 2021 PREDICTION

NAME.....

INDEX NO.....

SCHOOL.....

SIGN.....

DATE.....

232/1

## PHYSICS

PAPER 1 (Theory)

TIME 2 HOURS

### INSTRUCTIONS TO CANDIDATES

- Write your *name* and *index number* in the spaces provided.
- Mathematical tables and non-programmable calculators may be used.
- This paper consists of section A and section B.
- Attempt *all* the questions in the spaces provided.

### FOR OFFICIAL USE

SECTION	QUESTIONS	MAXIMUM SCORE	CANDIDATE'S SCORE
A	1 – 11	25	
B	12	12	
	13	12	
	14	11	
	15	12	
	16	08	
	<b>TOTAL</b>	<b>80</b>	



**SECTION A (25 MARKS)**

*Answer questions in the spaces provided.*

1. The figure below shows a measuring cylinder containing some water.

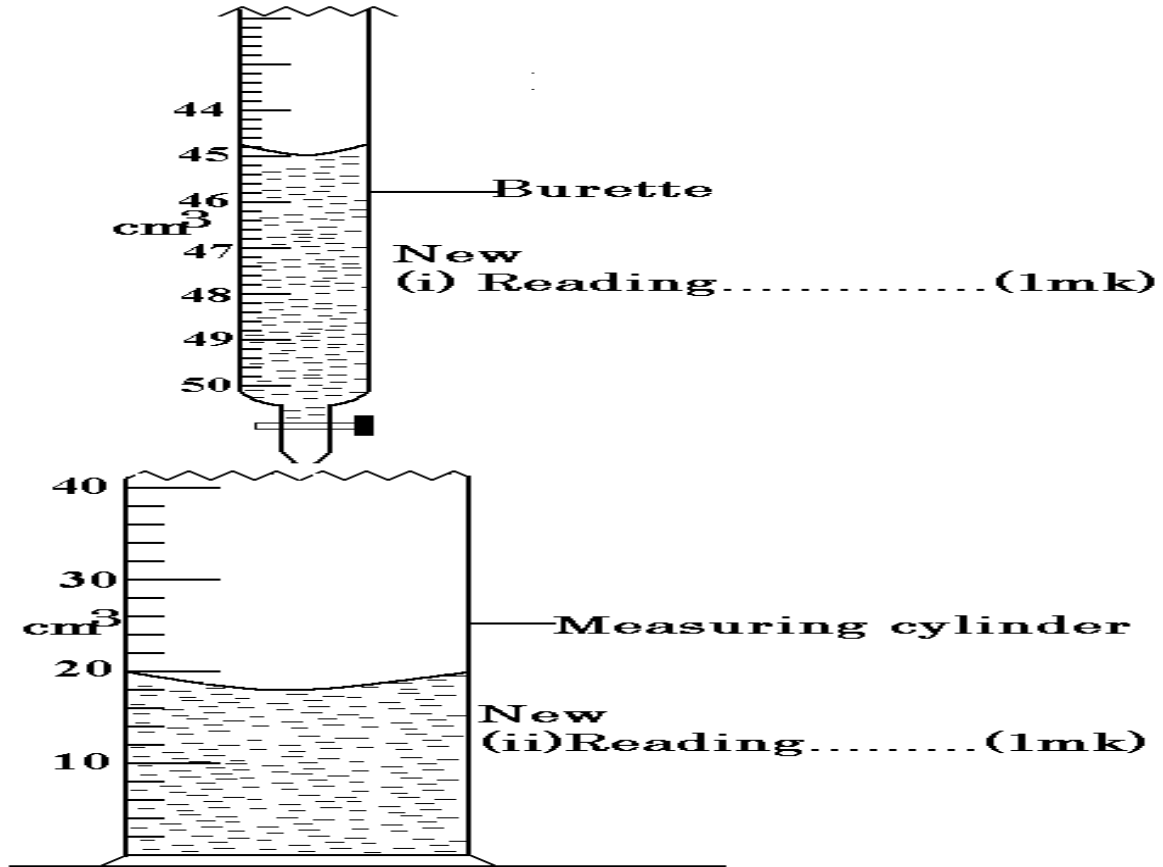

Another 3cm<sup>3</sup> of water was added in to the cylinder from a burette delivering volumes from 0cm<sup>3</sup> to 50 cm<sup>3</sup>. Record in the spaces provided the **new reading** indicated on each vessel. (2 marks)

.....

.....

.....

2. Sketch a vernier callipers scale reading 3.41 cm. (1mark)

.....

.....

.....

.....

3. A uniform metallic bar of length 100cm and mass 40kg is supported horizontally by two vertical spring balances A and B as shown below.



Balance A is 20cm from one end while balance B is 30cm from the other end. Find the reading of each individual balance AB. (3 marks)

.....

.....

.....

.....

.....

4. The reading on a mercury barometer at Mombasa is 760mm. Calculate the pressure at Mombasa (density of mercury is  $1.36 \times 10^4 \text{Kgm}^{-3}$ ) (3 marks)

.....

.....

.....

.....

.....

.....

5. Explain the cause of random motion of smoke particles as observed in Brownian motion experiment using a smoke cell. (1 mark)

.....

.....

.....

6. When a Bunsen burner is lit below a wire gauze, it is noted that the flame initially burns below the gauze as shown in the figure below. After sometime the flame burns below as well as above the gauze.

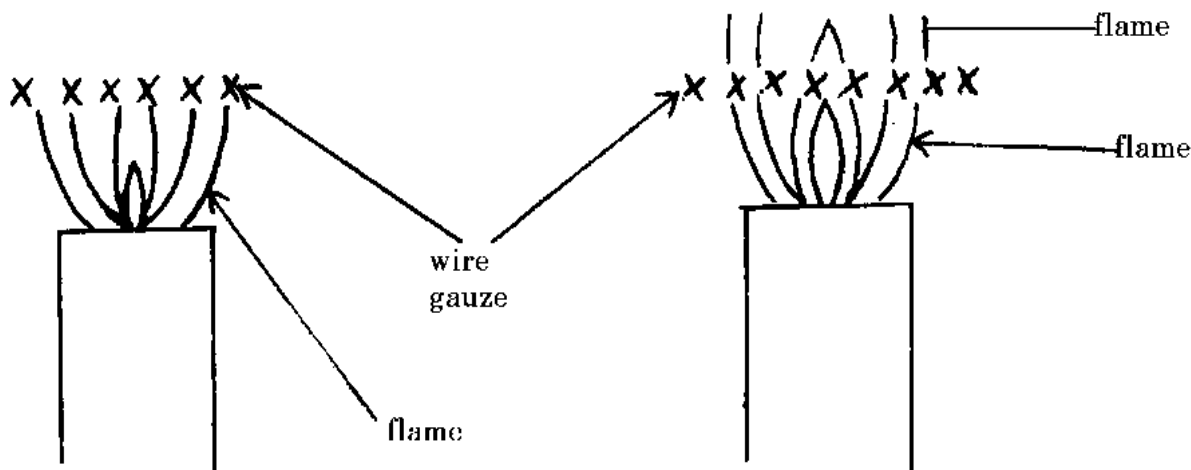

Explain this observation

(2 marks)

.....

.....

.....

.....

.....

7. The diagram below shows a flask fitted with a glass tube dipped into a beaker containing water at room temperature. The cork fixing the glass tube is tight.

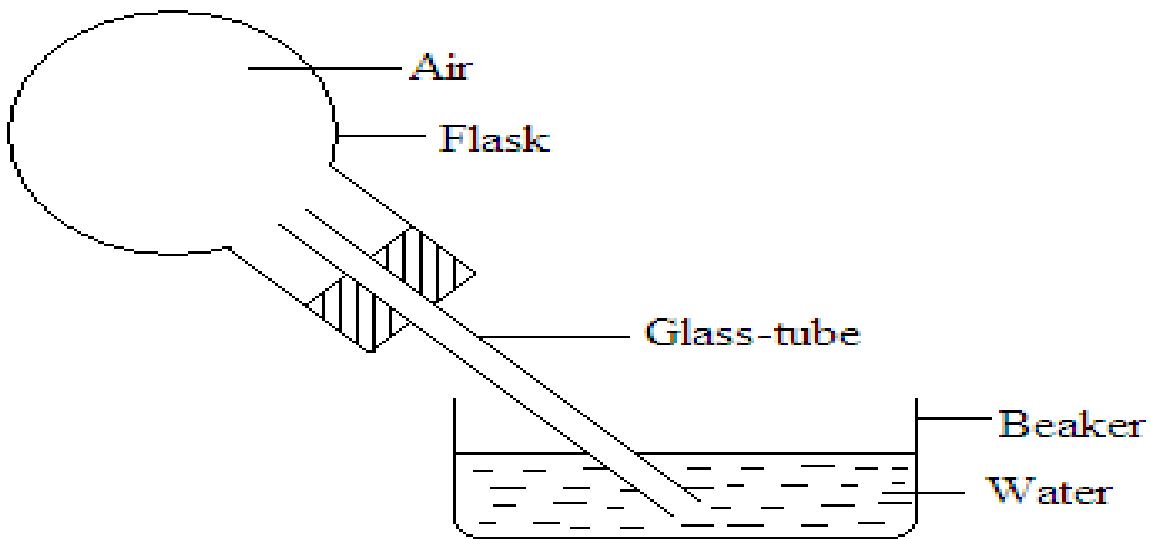

**State with reason** what would be observed if cold water is poured on to the flask. (2marks)

.....

.....

.....

.....



8. A resultant force  $F$  acts on a body of mass ' $m$ ' causing an acceleration of  $a_1$  on the body. When the same force acts on a body of mass  $2m$ , it causes an acceleration of  $a_2$ . Express  $a_2$  in terms of  $a_1$ .  
(3 marks)

.....

.....

.....

.....

.....

.....

.....

9. The diagram below shows three identical springs which obey Hooke's law.

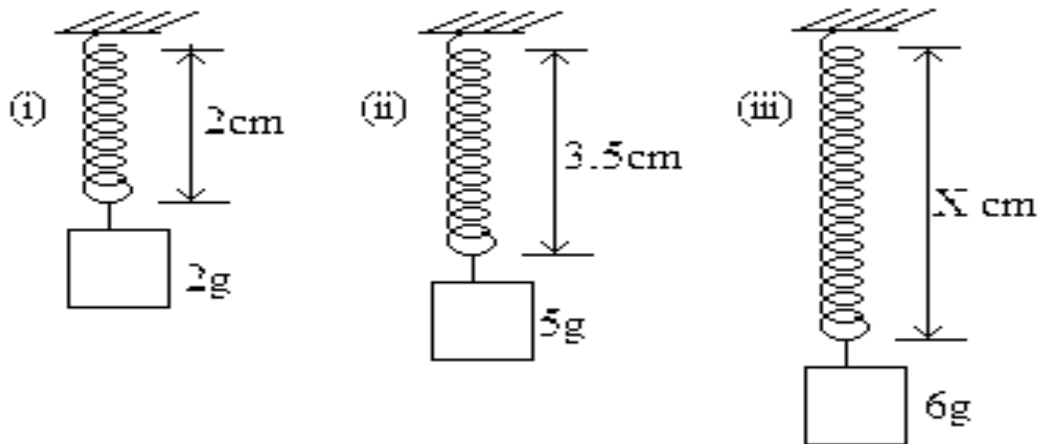

Determine the length  $X$ . (3 marks)

.....

.....

.....

.....

.....

10. The figure below shows a pith ball being lifted in to a funnel end of a blower.

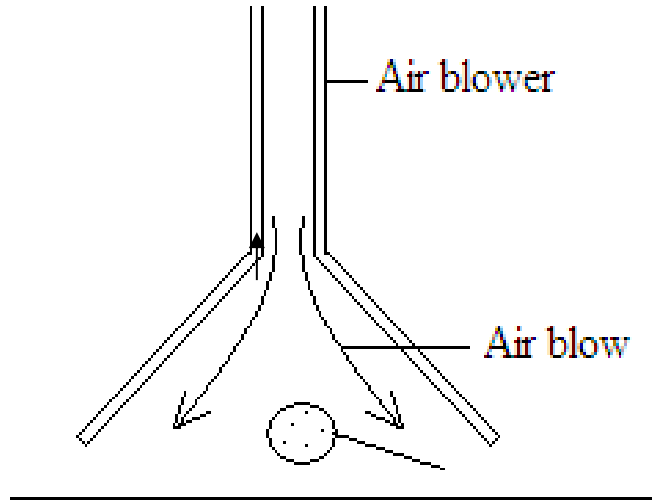

Explain this observation

(2 marks)

.....

.....

.....

.....

11. A metal ball suspended vertically with a wire is displaced through an angle  $\theta$  as shown in the diagram below. The body is released from A and swings back to 'B'.

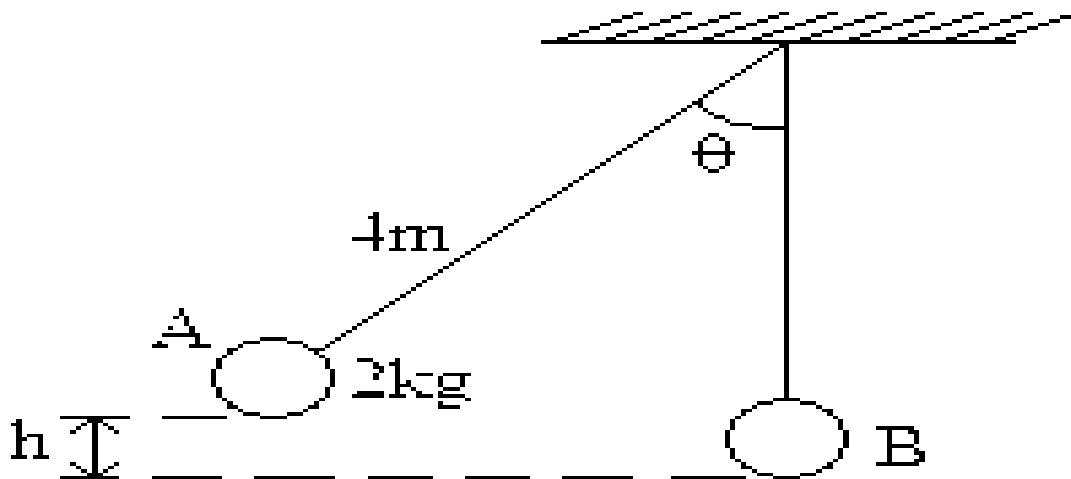

Given that the maximum velocity at the lowest point B is 2.5 m/s. Find the height h from which the ball is released ( $g = 10m/s^2$ )

(3 marks)

.....

.....

.....  
 .....  
 .....

**SECTION B (55 MARKS)**

*Answer questions in the spaces provided.*

**12. (a)** When is work done? **(1mark)**

.....  
 .....  
 .....  
 .....

**(b)** The table below shows energy conversion from form A to form B and the transducers in use.  
 Complete the table **(5marks)**

<b>Form A</b>	<b>Form B</b>	<b>Transducer</b>
(i) Chemical	Electrical	_____
(ii) Solar	_____	Plants
(iii) _____	Electrical	Thermocouple
(iv) Electrical	Kinetic	_____
(v) Electrical	_____	Loudspeaker

**(c)** When an electric pump whose efficiency is 70% raises water to a height of 15m, water is delivered at the rate of  
 350 litres per minute.



**(i)** What is the power rating of the pump?

**(3marks)**

.....

.....

.....

.....

.....

.....

.....

**(ii)** What is the energy lost by the pump per second.

**(3marks)**

.....

.....

.....

.....

.....

.....

.....



13. The figure below shows a set up that can be used to determine the specific heat capacity of a metal block.

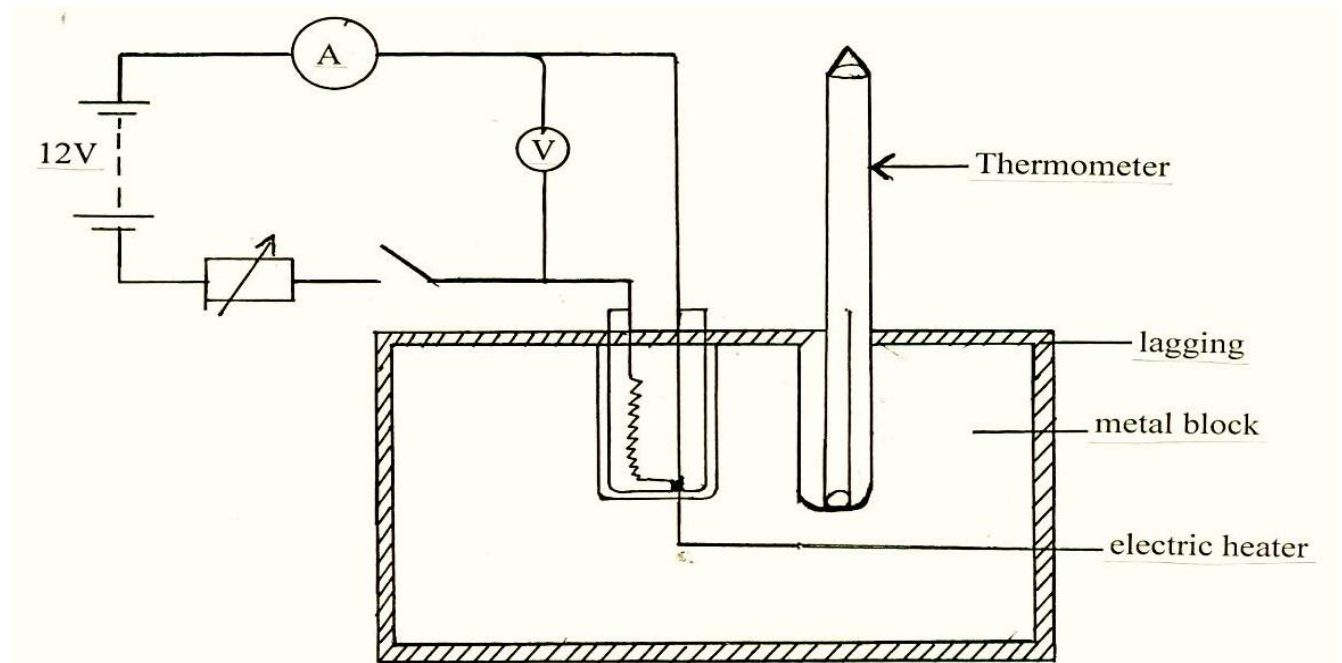

(i) State the measurement that should be taken in the experiment to determine specific heat capacity of the metal block. **(3marks)**

.....

.....

.....

.....

.....

(ii) Show how the measurement above can be used to determine the specific heat capacity of the metal block. **(2marks)**

.....

.....

.....

.....  
.....

(iii) State the function of the following in the set up

(I) Lagging (1mark)

.....  
.....  
.....

(II) Drops of oil in the holes containing thermometer and the electric heater (1mark)

.....  
.....  
.....  
.....

(b) A copper can together with stirrer of total heat capacity 600J/K contains 200g of water at 15<sup>0</sup>C. Dry steam at

100<sup>0</sup>C is passed through the water while stirring until it reaches a final temperature of 55<sup>0</sup>C. Calculate the mass of the steam condensed. Take specific heat of capacity of water as 4200J/Kgk and specific latent heat of steam as 2,260,000J/kg (5marks)

.....  
.....  
.....  
.....  
.....  
.....



**14. (a)** A car is negotiating unbanked circular track. State two factors that will determine the critical speed of the car. **(2marks)**

.....

.....

.....

.....

**(b)** Given that the car above has a mass of 1000kg and the circular path has a radius of 25m. Determine the

maximum speed with which the motorist can travel so as not to skid if the frictional force between the tyres

and the road is 6500N.

**(3marks)**

.....

.....

.....

.....

.....

.....

**(c)** A 200g mass tied to a string is being whirled in a vertical circle of radius 32cm with uniform speed, At the

lowest position the tension in the string is 10.5N. Calculate:-

**(i)** The speed of the mass

**(3marks)**

.....

.....



.....  
.....

(ii) The tension in the string when the mass is at the uppermost position of the circular path  
(Take  $g = 10\text{m/s}^2$ ) (3marks)

.....  
.....  
.....  
.....

15. a) (i) State Archimedes' principle. (1 mark)

.....  
.....  
.....

(ii) The figure below shows a rectangular object of mass 100kg tethered to the sea-bed by a wire. The dimensions are 4m x 1.5m x 2m.

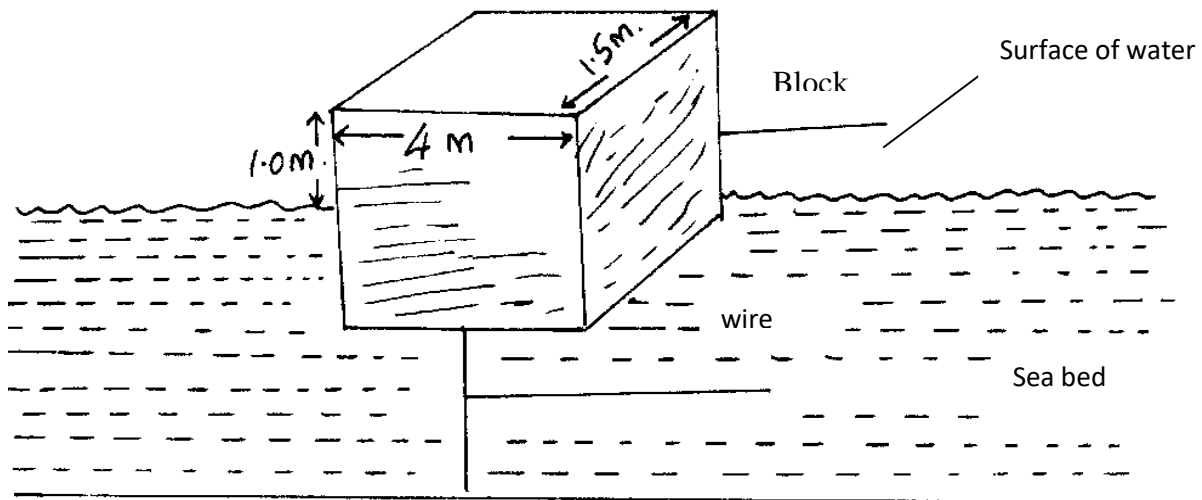



Calculate the :-

**(I) Weight of sea water displaced by the buoy (density of sea water =  $1100\text{kg/m}^3$ ) (3 marks)**

.....

.....

.....

.....

.....

.....

**(II) Upward force exerted on the buoy by the water. (1mark)**

.....

.....

.....

.....

.....

**(III) Tension in the wire (2 marks)**

.....

.....

.....



.....  
.....

(b) A test tube of mass 10g and uniform cross-sectional area  $4\text{cm}^2$  is partly filled with lead shots and floats vertically in water with 5cm of its length submerged.

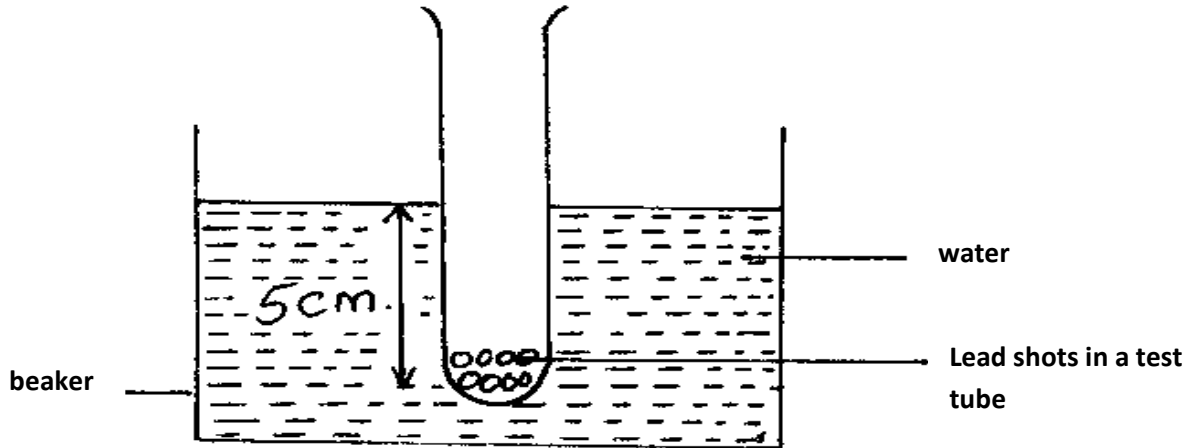

Find the:-

(i) Mass of the lead shots.(density of water =  $1\text{g/cm}^3$ ) (3 marks)

.....  
.....  
.....  
.....  
.....

(ii) Length of the test tube that would be submerged in a liquid of density  $0.75\text{g/cm}^3$ .(2 marks)

.....  
.....

.....  
.....

**16. (a)** A car sets out from rest with constant acceleration of  $0.5\text{m/s}^2$  for 10s. It then continues at a constant velocity

for further 25s and then decelerates to rest in 5s.

**(i)** Draw a velocity-time graph for the whole journey. **(2 marks)**

**(ii)** find the average speed for the whole journey. **(3 marks)**

.....  
.....  
.....  
.....  
.....

**(b)** A body is moving eastwards at  $10\text{m/s}$  and it decelerates at  $2.0\text{m/s}^2$ . Determine its velocity after it has traveled 24m. **(3 marks)**

.....  
.....



.....

.....

.....

.....

.....



# KCSE 2021 PREDICTION

NAME.....

INDEX NO.....

SCHOOL.....

SIGN.....

DATE.....

232/2

## PHYSICS

Paper 2

2 HOURS

### Instructions to candidates

1. Write your **name**, **index number** and the **name** of your school in the spaces provided above.
2. **Sign** and write the **date** of examination in the spaces provided above.
3. Answer **all** questions in this question paper.
4. Answers to **all** questions **must** be written in the spaces provided in this booklet.
5. This paper consists of Two Sections **A** and **B** in the spaces provided.
6. All working **MUST** be clearly shown.
7. Electronic calculators and mathematical tables may be used.
8. KNEC mathematical tables and non-programmable silent electronic calculators **may be** used.

**Note:**

- Take acceleration due to gravity,  $g = 10\text{m/s}^2$ ,  $C = 3.0 \times 10^8\text{ms}^{-1}$ ,  $M_e = 9.11 \times 10^{-31}\text{kg}$ ,  $e = 1.6 \times 10^{-19}\text{C}$

### For Examiner's Use Only

Section	Question	Maximum score	Candidate's score
A	1-12	25	
B	13	11	
	14	13	
	15	09	
	16	10	
	17	12	
	TOTAL	80	



1. Figure 1 shows two plane mirrors AB and BC inclined at an angle of  $100^\circ$ . A ray of light is incident on mirror AB at an angle  $50^\circ$ . Complete the diagram to show the path of the ray on reflection from mirror BC. 3mks

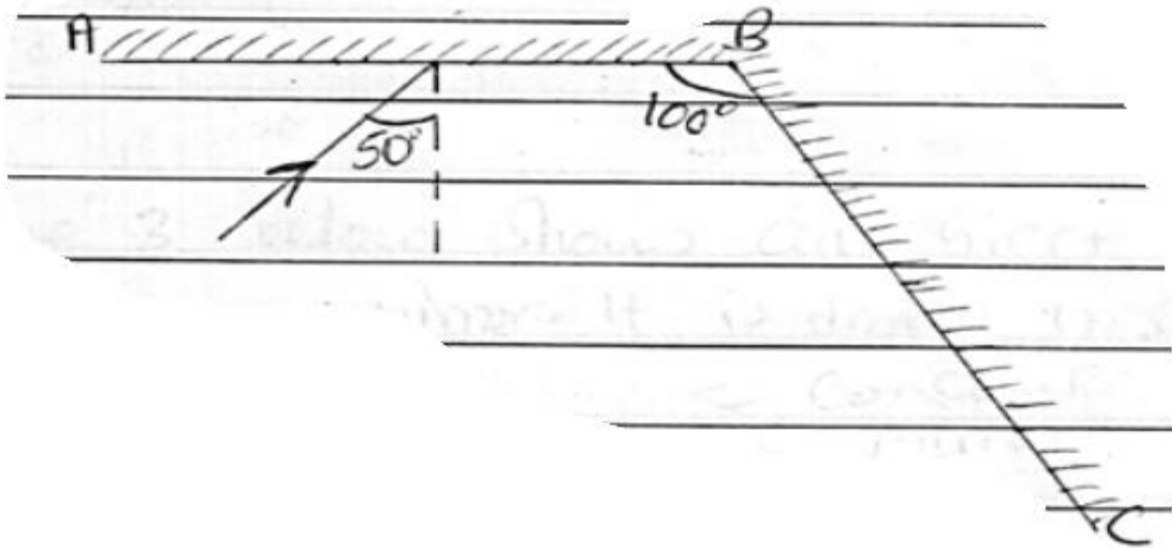

2. Explain what is observed when an uncharged aluminum sphere is brought close to a positively charged electroscope (2mks)

.....

.....

.....

.....

.....

3. The chart below shows an arrangement of different parts of the electromagnetic spectrum.

Radio wave	A	B	Visible light	C	D	E
------------	---	---	---------------	---	---	---

- a) Name the radiation represented by A. (1mk)

.....

.....

**b)** Name one detector of radiation **C** **(1mk)**

.....  
.....

**c)** State one difference in mode of production of radiation **D** and **E** **(1mk)**

.....  
.....

**4.** A lady holds a large concave mirror of focal length 1m, 80cm from her face. State one characteristic of her image in the mirror. **(1mk)**

.....  
.....

**5.** A ship produces an ultrasonic pulse and an echo is received from the sea bed after 0.8s. Assuming the speed of sound in sea water is 1500m/s, calculate the depth of the sea **(3mks)**

.....  
.....  
.....  
.....



6. Figure 2 shows a radioactive substance contained in a thick lead box and emitting radiations B, C and D. Passing through a strong field directed out of the plane of the paper.

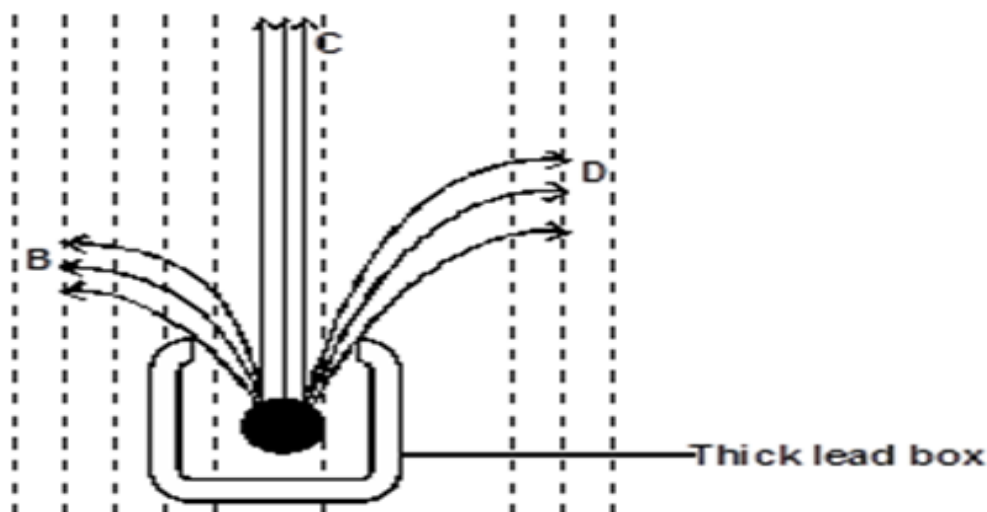

- (a) Identify the radiation labelled D. (1 marks)

.....

.....

- (b) Uranium -234 undergoes a radioactive decay by emitting 2-alpha particles, as represented by the equation shown below.

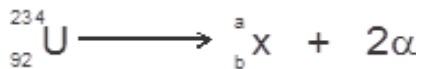

Find the value of a and b

(2 marks)



7. When a bulb is connected between two plates of a simple cell the bulb lights up. However, the brightness of the bulb fades after a while. why does the brightness fall? **(1 mark)**

.....

.....

.....

.....

8. Draw the magnetic field lines due to the configuration shown below. **(1 mark)**

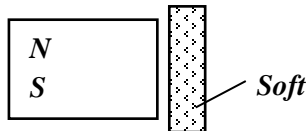

9. How much current is taken by a bulb rated 100w, 250V. **(2 marks)**

.....

.....

.....

.....

10. The diagram in the figure 5.0 below shows an object O placed in front of a converging lens.

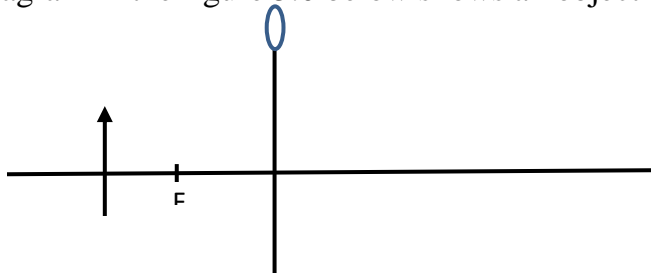

Using ray diagram determine the position of the image.

(3 marks)

.....

.....

.....

.....

.....

11. The figure 5 below shows a displacement- time graph for a wave.

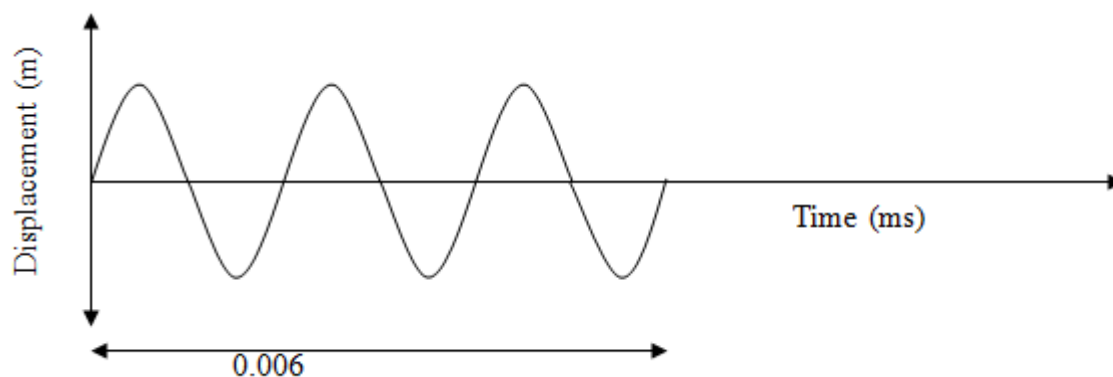

Determine the frequency of the waveform

(3mks)

12. Figure 2 shows an experimental arrangement.  $S_1$ ,  $S_2$  and  $S$  are narrow slits.

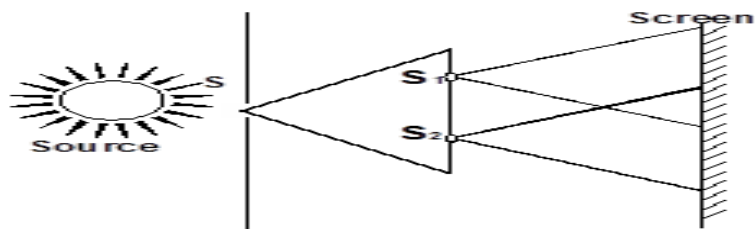

State what is observed on the screen when the source is monochromatic light.

(1 mark)

**SECTION B (55 MARKS)**

13.(a) In an experiment with a parallel plate capacitor by form three students, the charge which was stored was measured for different values of charging p.d. From the results obtained, the following graph was plotted.

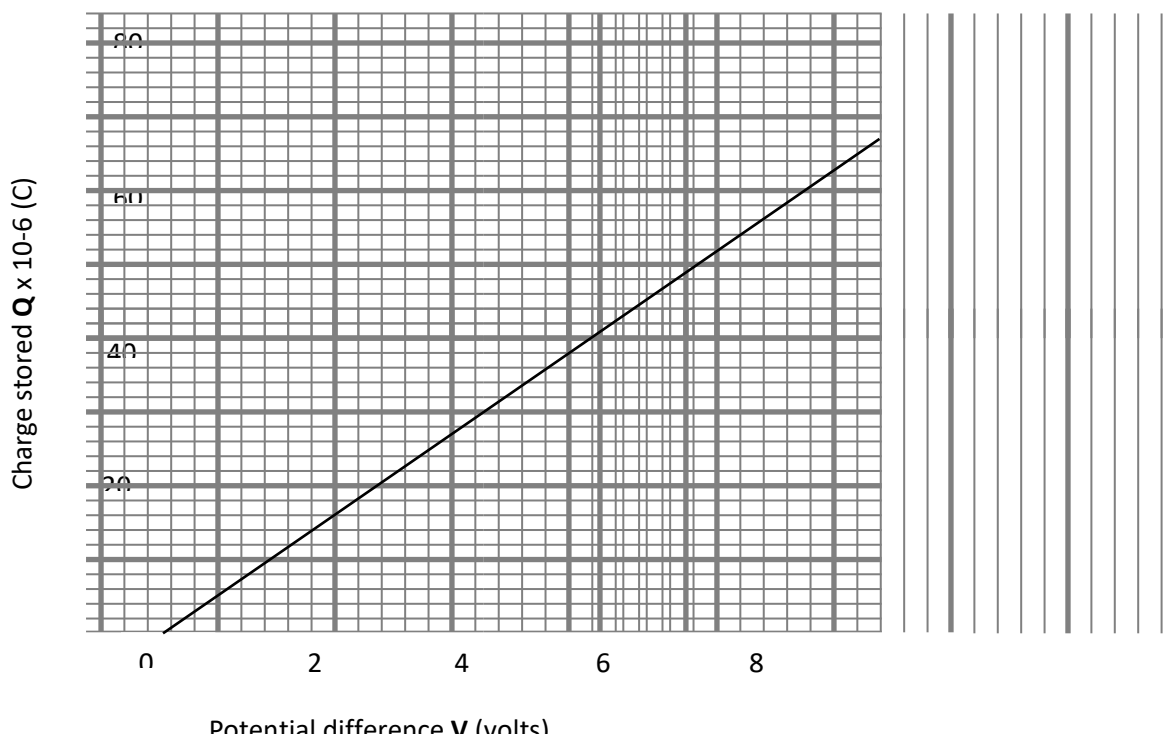

**(i)** Use the graph to calculate the capacitance of the capacitor used in the experiment.  
**(3mks)**

**(ii)** State two factors affecting the capacitance. **(2mks)**

.....

.....

.....

**(b)** A positively charged rod is brought near a flame as shown, State and explain what is observed **(2mks)**

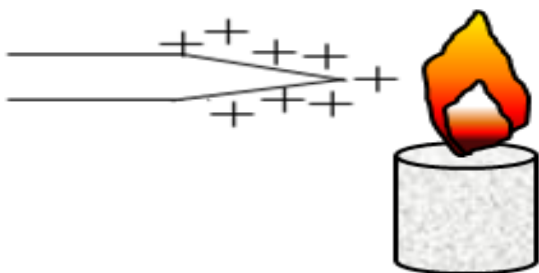

**(c)** The figure below shows part of a circuit containing two capacitors of  $4\mu\text{F}$  and  $6\mu\text{F}$  respectively. Determine the p.d. across AB given that the total charge in the capacitors is  $1 \times 10^{-6}\text{C}$   
**(2mks)**

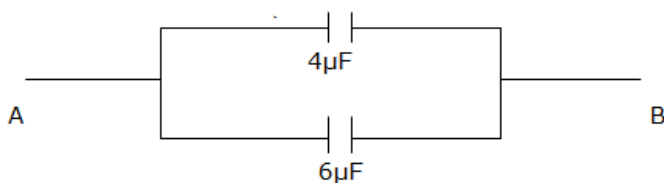

d) the figure below shows a charging circuit of a capacitor. State two ways in which one can tell the capacitor is fully charged (2mks)

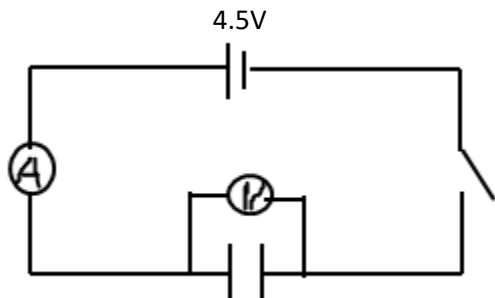

14..a) The diagram below is a section of a house wiring system.

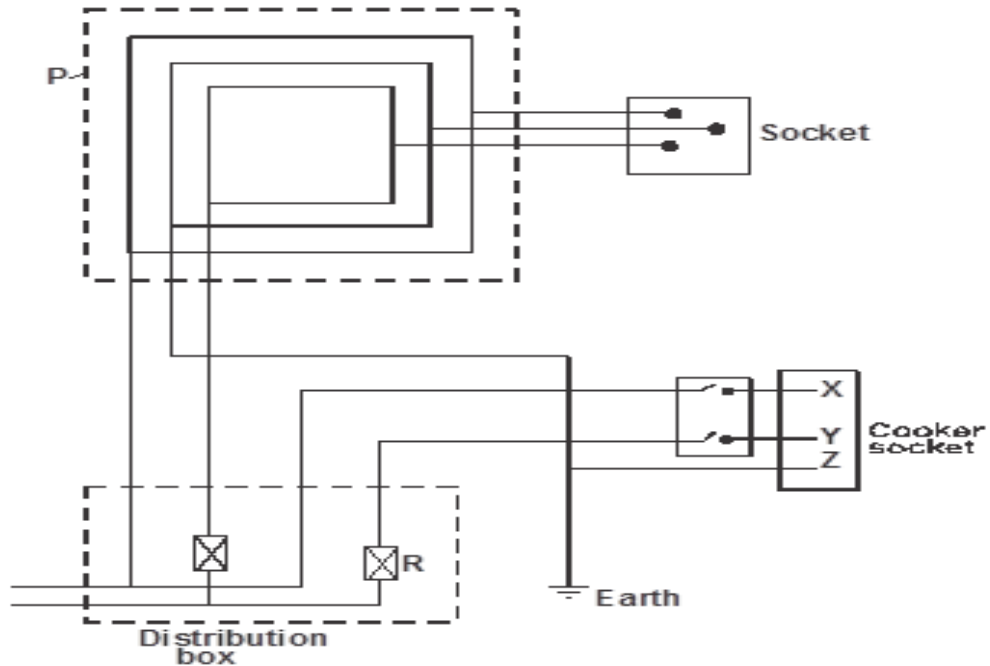

Name:

i) Circuit labelled P

(1 mark)

.....

.....

ii) Terminals labelled X and Y

(2marks)

.....

.....

.....

iii) Explain why R is connected to Y and not X.

(1 mark)

.....

.....

**iv) Why is the earthing necessary in such a circuit?**

**(1 mark)**

.....  
.....

**b) The cost of electricity per kilowatt hour- kWh is Ksh.8, determines how much a household running a device rated 1500W continuously for  $1.08 \times 10^5$  seconds, would pay.**

**(2 marks)**

.....  
.....  
.....

**c) Explain reason for transmission of electrical power over along distance at very high voltage.**

**(1 mark)**

.....  
.....  
.....

**d) Explain why for transmission of electrical power over long distance, alternating current (a.c) is preferred to a direct current (d.c)**

**(1 mark)**

.....  
.....  
.....



(e) Figure below shows suspended metre rule in equilibrium balanced by the magnet and weight shown. The iron core is fixed to the bench.

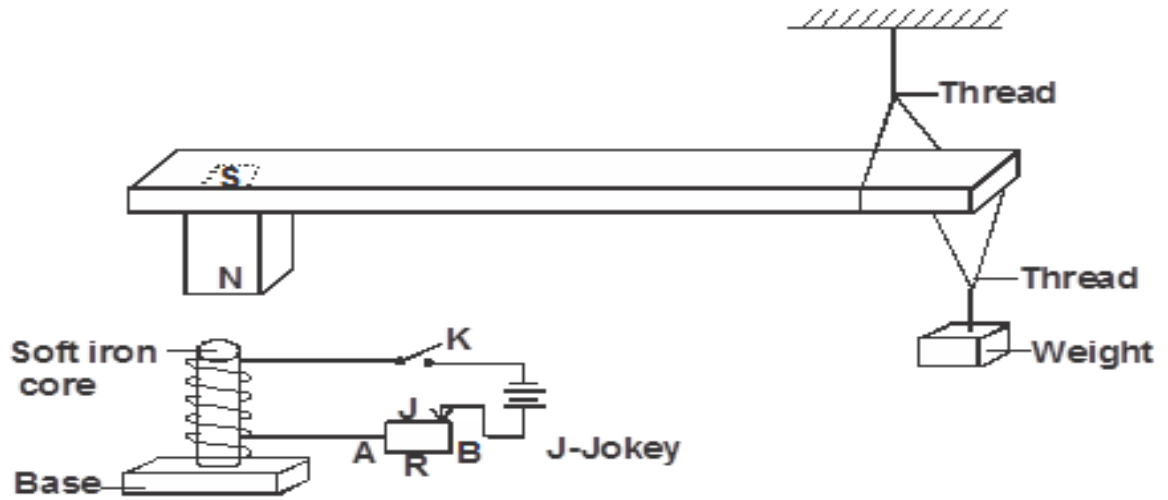

i) State and explain the effect on the metre rule when the switch S is closed. (2 marks)

.....

.....

.....

ii) Suggest how J on the set up can be varied to have the effect in (i) above faster. (1mk)

.....

.....

.....

iii) State the effect on the metre rule when the terminals of battery are reversed. (1 mark)

.....

.....

.....



- 15.. (a) The figure 10.0 below shows a ray of white light dispersed in a triangular prism. The speed of violet light in the prism is  $1.88 \times 10^8 \text{m/s}$ .

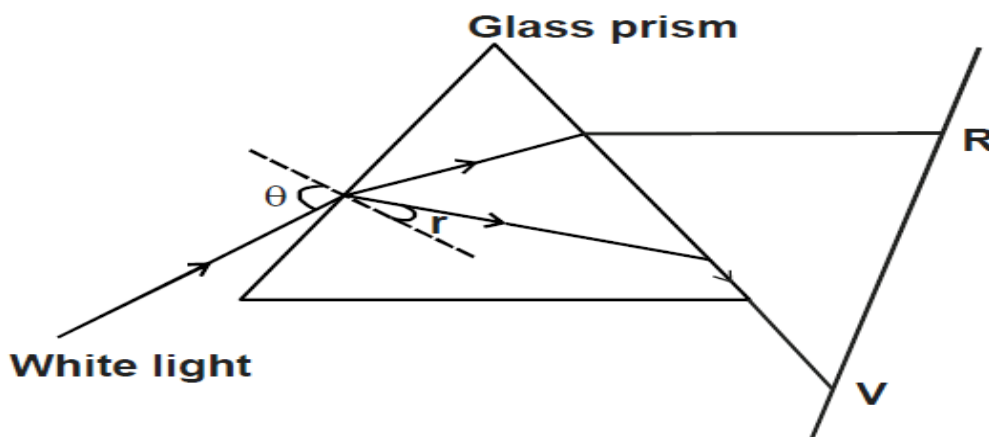

Glass prism

- i) Explain how glass disperses white light into red and violet bands. (1 mark)

- ii) Determine the refractive index of the prism material for light (take speed of light in vacuum =  $3 \times 10^8 \text{m/s}$ ) (2 marks)

- iii) Show on the figure the critical angle C for violet light and determine its value. (3 marks)

- iv) On the same figure, sketch the part of red light after white light strikes the prism if the prism was replaced by another of similar shape but lower refractive index. (Use a dotted line for the answer) (1 mark)

b) State one condition under which total internal reflection occurs (1mk)

(c) The diagram below shows a ray of light entering a thin optical tube.

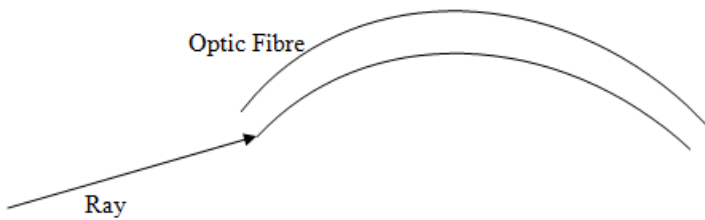

Draw on the same diagram the route taken by the ray until it leaves the tube  
(1mk)

16.(a).Name two properties common to both X-rays and gamma rays. (2 marks)

(b).The figure below shows an X-ray tube.

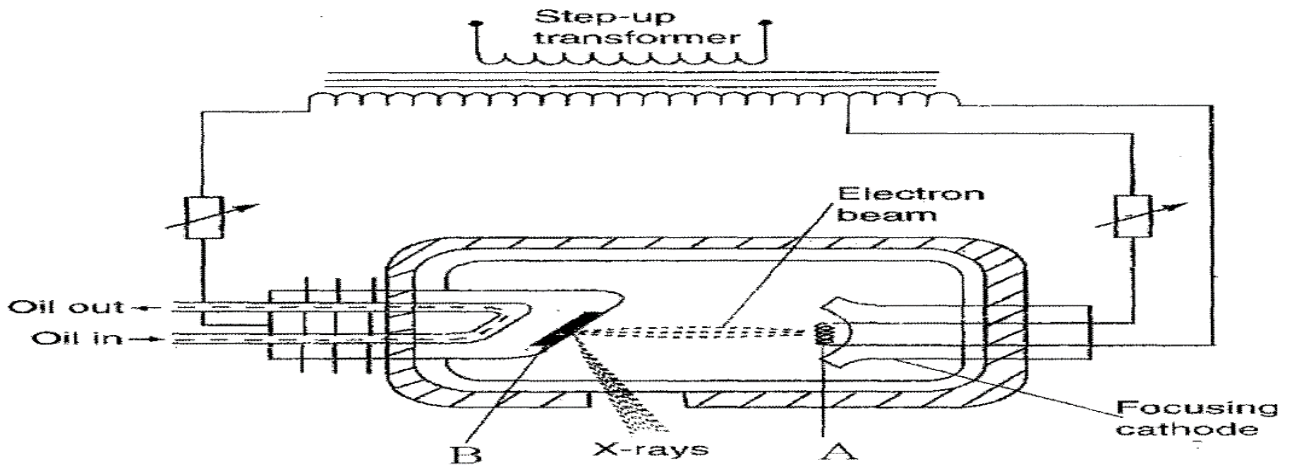

(i) Name the parts labelled A and B (2 marks)

A .....

B.....

**(ii)** State the function of part A above **(1 mark)**

A .....

**(iii)** State the property of part B above **(1 mark)**

**c)** For a given source of X-rays, how would the following be controlled?

**(i)** Penetration power. **(1 mark)**

**(ii)** Intensity. **(1 mark)**

**d)** An X-ray tube operates with a potential difference of 150 kV between the cathode and the anode. Only 0.5% of the kinetic energy of each electron is converted into X-rays. (Take electronic charge,  $e = 1.6 \times 10^{-19}\text{C}$ ). Determine the maximum kinetic energy of the X-rays produced **(3 marks)**

**17.**The diagram below shows a coil connected to a zero-centered galvanometer **G**.

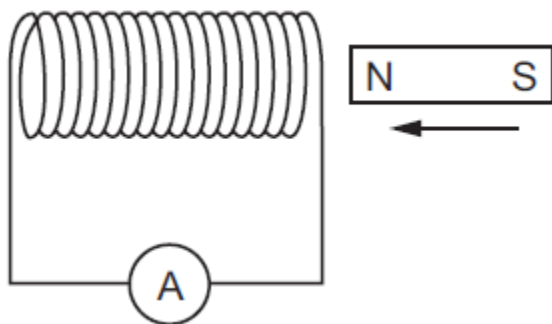

**(i)** Show on the diagram direction in which the galvanometer deflects. **(1 mark)**

- (ii)** Explain the deflection of the galvanometer when the magnet is moved slowly towards the coil.

**(3 mark)**

**(b)** A 240V mains transformer has 1000 turns in the primary and  $N_s$  turns in the secondary if it is used to supply 12V, 24W lamp.

- (i)** How many turns,  $N_s$  are there in the secondary. **(2 marks)**

- (ii)** What is the efficient of the transformer if the current drawn from the 240V supply is 12mA. **(3 marks)**

- (iii)** State two ways in which power loss can be minimized in a transformer. **(2 marks)**



# KCSE 2021 PREDICTION

NAME.....

INDEX NO.....

SCHOOL.....

SIGN.....

DATE.....

232/3

## PHYSICS

Paper 3

2 HOURS

### Instructions to candidates

- Write your **name**, **index number** and the **name** of your school in the spaces provided above.
- Sign** and **write** the **date** of examination in the spaces provided above.
- Answer **all** questions in this question paper.
- Answers to **all** questions **must** be written in the spaces provided in this booklet.
- This paper consists of Two Sections **A** and **B** in the spaces provided.
- All working **MUST** be clearly shown.
- Electronic calculators and mathematical tables may be used.
- KNEC mathematical tables and non-programmable silent electronic calculators **may be** used.
- Candidates should check to ascertain that all pages are printed as indicated and that no questions are missing.

### For Examiner's Use Only

Question	Maximum score	Candidate score
1	20	
2	Part (A) 14	
	Part (B) 6	
<b>Total score</b>	<b>40</b>	



1. You are provided with:

- ✓ A pendulum bob with a piece of thread attached
- ✓ Two wooden blocks
- ✓ Clamp, boss and retort stand
- ✓ Metre rule
- ✓ Half metre rule attached to wooden block
- ✓ Cellotape about 10cm long
- ✓ Stop watch

**Proceed as follows**

- a) Fix the thread between the two wooden blocks and fasten in the clamp. Adjust the thread so that the length  $L$  shown below is 50.0cm. Fix the metre rule horizontally to the bench using the cellotape provided. Adjust the clamp so that the pendulum bob is next to the end of the metre rule as shown.

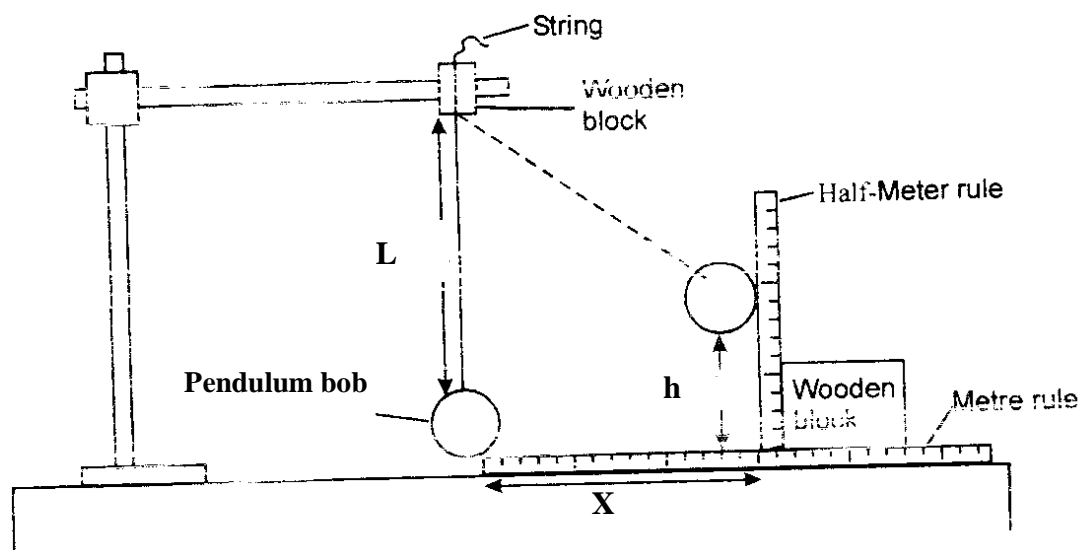

- i) Displace the marble by a horizontal distance  $x = 20\text{cm}$  and measure the corresponding vertical displacement  $h =$  \_\_\_\_\_ cm (1 mark)

- ii) Repeat the experiment to find  $h$  for each of the following values of  $x$  : 25cm, 30cm, 35cm, 40cm and 45cm. Complete the table below. (6 marks)

$x$ (cm)	$h$ (cm)	$x^2$ (cm <sup>2</sup> )	$\frac{x^2}{h}$ (cm)
20		400	
25		625	
30		900	
35		1225	
40		1600	

45		2025	
----	--	------	--

iii) Plot the graph of  $\frac{x^2}{h}$  (y – axis) against h.

(5 marks)

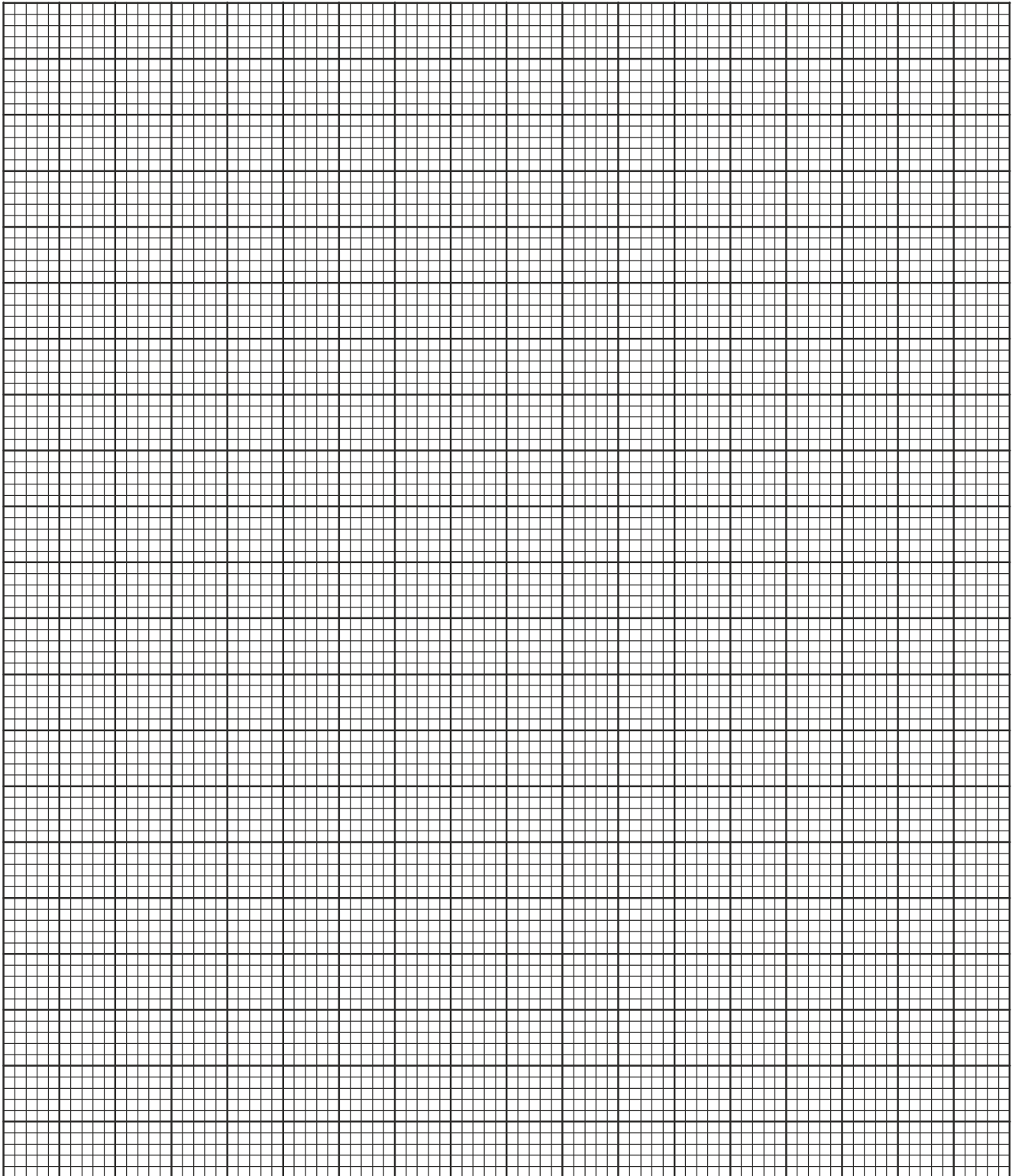

iv) Determine the slope of the graph.

(2 marks)



v) From the graph, find the value of  $\frac{x^2}{h}$  when  $h = 0$ . **(1 mark)**

b) Raise the clamp slightly without changing the length  $L$  so that the pendulum is free to swing.

i) Determine the period,  $T$ , for one oscillation by timing 20 oscillations.

Time for 20 oscillations = \_\_\_\_\_seconds **(1 mark)**

ii) Period  $T$  = \_\_\_\_\_ seconds **(1 mark)**

iii) Calculate the value of  $P$  from the following equation. **(3 marks)**

$$T = 2\pi \sqrt{\frac{P}{g}} \text{ where } g = 10\text{ms}^{-2}$$





**Question two.**

**PART A**

- ✓ A wire mounted on a meter scale and labelled X.
- ✓ A switch.
- ✓ Ammeter
- ✓ 3 cell holders.
- ✓ 3 new size D dry cells.
- ✓ Seven connecting wires, at least three with crocodile clips both ends.
- ✓ Jockey.

Proceed as follows.

(a) Connect the circuit as shown in the **figure 2** below.

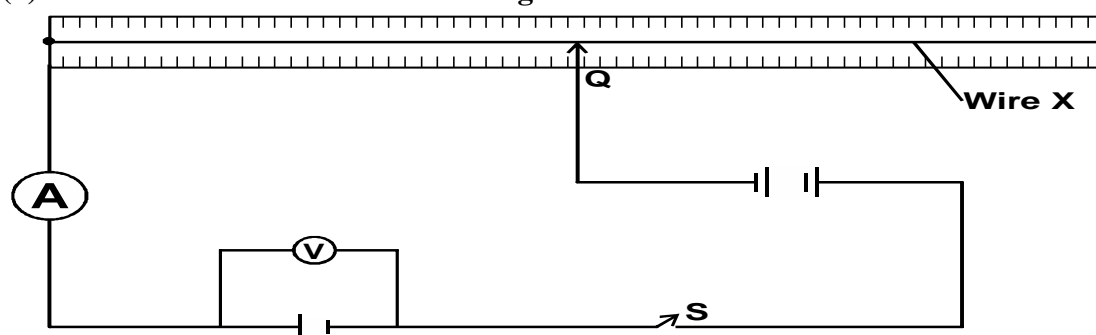

(b) Adjust the contact Q so that the reading on the voltmeter is 1.3V, note the reading of the current and record it in table below.

P.d V(volts)	1.3	1.2	1.1	1.0	0.9	0.8	0.7
Current I(A)							

(c) Repeat the procedure above for the values of voltage given in the table and record the corresponding values of the current. **(3 marks)**

(d) Plot a graph of voltage  $V$  (y-axis) against current  $I$ (A)

(5 marks)

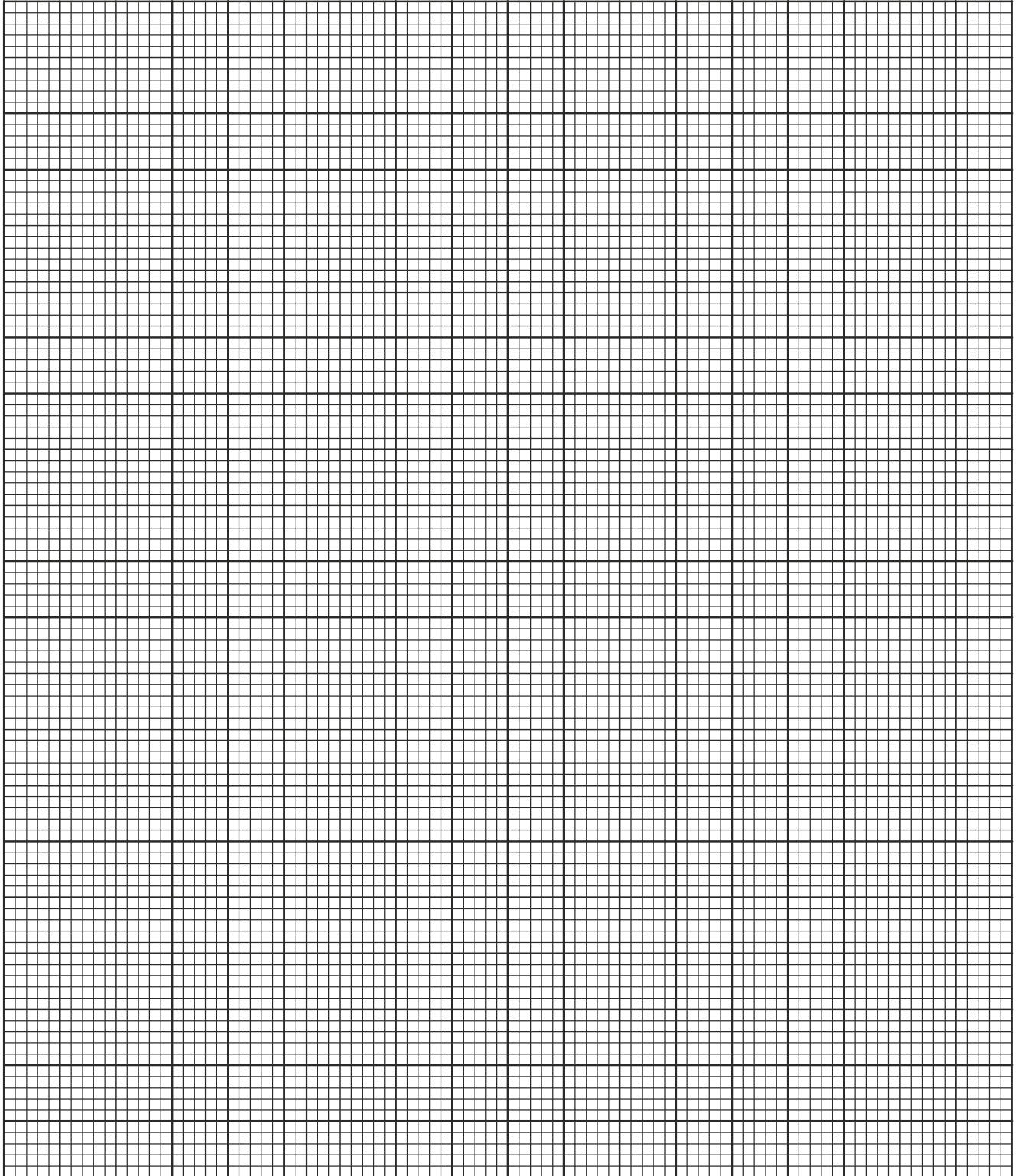

(e) Determine the gradient of the graph.

(3 marks)

(f) State the equation relating the voltage  $V$ , the internal resistance  $r$  and the e.m.f of the cell (1 mark)

(g) From the graph determine the values of

(i) The e.m.f ( $E$ ) of the cell.

(1 mark)

(ii) The internal resistance,  $r$  of the cell.

(1 marks)

**PART B**

You are provided with the apparatus below.

- ✓ Five optical pins and four office pins
- ✓ A plain white A4 piece of paper
- ✓ Soft board
- ✓ Glass slab

a) Place the glass slab on the white piece of paper and trace its outline. Secure it in place (In its position) by the office pins A, B, C, D as shown in the diagram below.

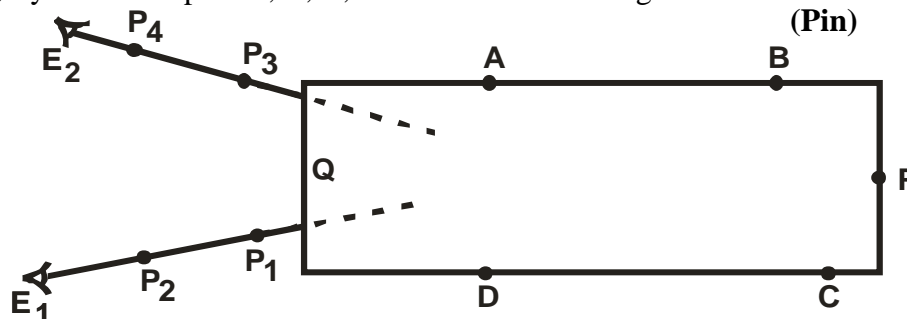

- b) i) Fix the pin P firmly at the end of the slab and with your eye  $E_1$  at the opposite of the slab fix pin  $P_1$  and then  $P_2$  in line with the image I of the pin (See diagram)  
Remove the pins  $P_1$  and  $P_2$  and mark their positions  $P_1$  and  $P_2$  respectively.
- ii) Similarly fix  $P_3$  and then  $P_4$  so that they are in line with the image I of P. Again remove the pins  $P_3$  and  $P_4$  and mark their positions respectively. Remove the glass slab and pins ABCD
- c) Join  $P_1P_2$  produced with the tracing of the slab outline. Join  $P_3P_4$  produced to intersect line  $P_1P_2$ . Label this point of intersection I, the supposed position of the image of pin P.

i) Submit the plain paper used in the experiment.

(2 marks)

ii) Measure the lengths QP and QI

QP

(1 mark)

QI

(1 mark)

iii) Determine the ratio  $\frac{QP}{QI}$

(1mark)



**iv)** What is the significance of the ratio in (II) above?

**(1 mark)**



# KCSE 2021 PREDICTION

NAME..... INDEX NO.....

SCHOOL..... SIGN.....

DATE.....

121/1

## MATHEMATICS

Paper 1

2 ½ HOURS

### Instructions to candidates

- (a) Write your Name and Index number in the spaces provided above.
- (b) The paper contains TWO sections: Section I and Section II.
- (c) Answer ALL the questions in section I and **strictly any five** questions from Section II.
- (d) All answers and working must be written on the question paper in the spaces provided below each question.
- (e) Show all the steps in your calculations, giving your answers at each stage in the spaces below each question.
- (f) Marks may be given for correct working even if the answer is wrong.
- (g) Non-programmable silent electronic calculators and KNEC mathematical tables may be used, except where stated otherwise.
- (h) **Candidates should check to ascertain that all pages are printed as indicated and that no questions are missing.**

### For Examiner's Use Only

#### Section I

1	2	3	4	5	6	7	8	9	10	11	12	13	14	15	16	Total

#### Section II

17	18	19	20	21	22	23	24	Total

--

Grand Total



**SECTION I (50 MARKS)**

**Attempt all the questions in the spaces provided**

1. Evaluate:  $\frac{-7+(-6)+9\div(-3)}{-4+(-3)+(-1)}$  (3 marks)

2. Use logarithms, correct to 4 decimal places, to evaluate (4mks)

$$\sqrt[3]{\frac{1.794 \times 0.038}{1.243}}$$

3 Given that  $\sin(x + 30)^\circ = -0.7660$ , find  $x$ , to the nearest degree, for  $0^\circ \leq x \leq 360^\circ$  (3mks)



**4** Simplify:  $\frac{2x^2 + 3xy - 2y^2}{y^2 - 4x^2}$  **(3 marks)**

**5** The interior angle of a polygon is eleven times the exterior angle. Find the sum of the interior angles of the polygon. **(3mks)**

**6** A line  $L_1$  passes through point (2, 3) and has a gradient of 3. Another line  $L_2$  is perpendicular to  $L_1$  and meets it at a point where  $y=6$ . Find the equation of  $L_2$  in the form  $ax + by = c$  where a, b and c are integers. **(3 marks)**



**7** Solve the following inequalities  $3^{x-2} < 27^x \leq 81^{(1/2x+2)}$  and represent the solution on a single number line. **(3mks)**

**8.** From the top of a building which is 15m above the ground, the angle of depression of an object on the ground is  $30^\circ$  and the angle of elevation of an aircraft vertically above the object is  $48^\circ$ . Calculate the height of the aircraft above the object. **(4 mks)**





***KCSE Predictions Marking Schemes - 0707550000 / 0705525657***

- 9.** A train moving at 120km/h approaches a bridge 50M long which is 120M away. If the train takes 9secs to completely cross the bridge, determine the length of the train in metres.  
**(3mks)**

- 10.** The diagram below is point of a figure which has rotational symmetry of order 4 about O.

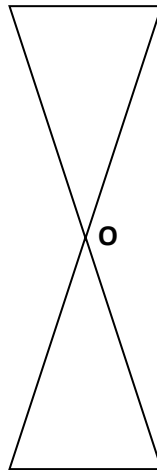

Complete the figure and draw all the lines of symmetry of the completed figure (use dotted lines of symmetry).  
**(3 marks)**



- 11.** Find the equation of the image of the line whose gradient is 3 and passes through the point (2, 1) under a translation by  $\begin{bmatrix} 3 \\ -2 \end{bmatrix}$  in the form  $y = mx + c$  **(3 marks)**

**12.A** Kenyan company received 90,000 US dollars (\$) which they converted into Kenya Shillings at the rates below:-

	Buying (Kshs)	Selling (Kshs)
1 \$	84.25	85.75
1 £	104.15	105.50

- (a)** Calculate the amount received in Kshs **(2 marks)**



- (b) The company used the money to buy a car. The money was therefore converted into sterling pound (£) and the car purchased from Britain at 10% discount. Determine the price of the car to the nearest sterling pound. **(2 marks)**

**13.** Solve for  $y$  in the equation

$$32^{y-3} \times 8^{y+4} = 64 \div 2^y$$

**(3 marks)**

**14.** Find the acute angle  $x$ , given that  $\cos x = \sin 2x$

**(2 marks)**



**15.** In the figure below, triangle DAC is similar to triangle ABC. If  $AB=9\text{cm}$  and  $CD=4\text{cm}$ , find AC

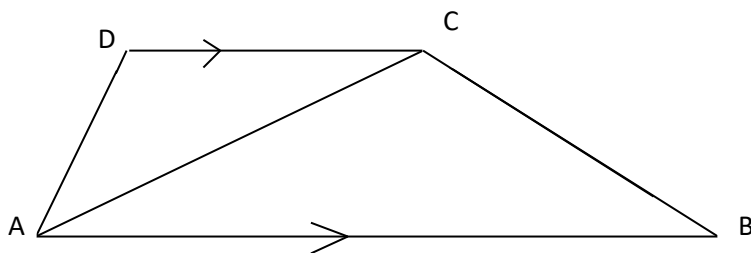

**(3mks)**

**16..** Mary is four times as old as her daughter. In seven years time, the sum of their ages will be 59 years. Determine their ages three years ago. **(3 marks)**



**SECTION II (50MKS)**

**ANSWER ANY FIVE QUESTIONS FROM THIS SECTION IN THE SPACES PROVIDED**

17. From a reservoir, water flows through a cylindrical pipe of diameter 0.2M at a rate of 0.35M/s.  
(Take  $\pi=22/7$ )
- a. Determine the number of litres of water discharged from the reservoir in one hour.

**(4mks)**

- b. The water flows from the reservoir for 18hours per day for 25days per month and serves a population of 2500 families. Determine the average consumption of water per family per month giving your answer to the nearest 100 litres. **(4mks)**

- c. The water is charged at the rate of sh. 4.50 per 100 litres. Calculate the average water bill per family per month. **(2mk)**



**18.** A solid is partly a cone and partly a hemisphere. The radius of the hemisphere is 5cm and the height of the solid is 17cm as shown in the figure below.

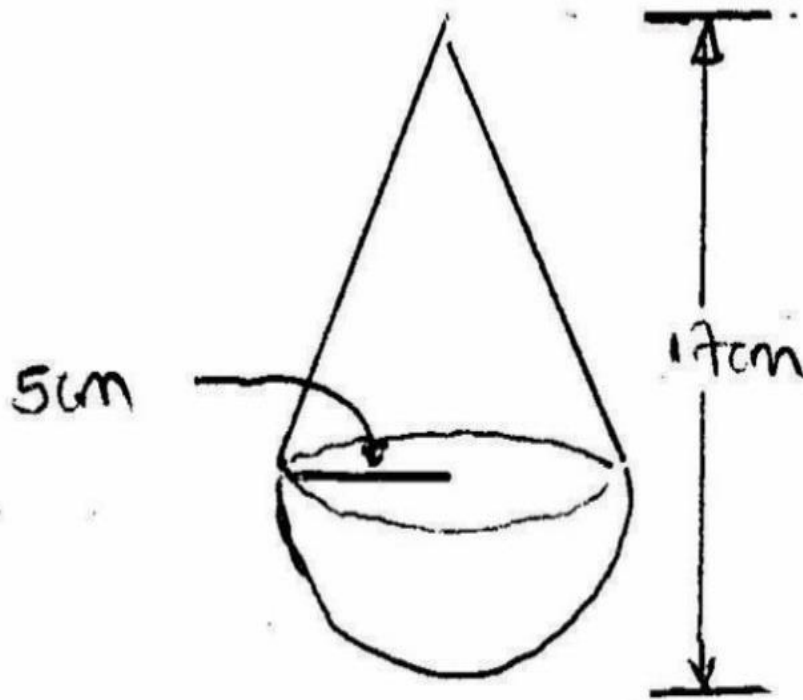

**(a)** Determine the volume of the:-

**(i)** conical part

**(2marks)**

**(ii)** hemispherical part

**(2marks)**

**(iii)**whole solid

**(2marks)**

**(b)** Calculate the surface area of the solid.

**(4marks)**



**19.** Two matrices A and B are such that  $A = \begin{pmatrix} k & 4 \\ 3 & 2 \end{pmatrix}$  and  $B = \begin{pmatrix} 1 & 2 \\ 3 & 4 \end{pmatrix}$ .

(a) Given that the determinant of  $AB=4$ , find K

(b) Rose bought 200 bags of sugar and 300 bags of rice for a total of sh. 850000. Jane bought 90 bags of sugar and 120 bags of rice for a total of sh. 360000. If the price of a bag of sugar is sh. X and that of a bag of rice is sh. Y

(i) Find by matrix method, the price of one bag of each item.

**(4mks)**





***KCSE Predictions Marking Schemes - 0707550000 / 0705525657***

(ii) Kali bought 225 bags of sugar and 360 bags of rice. He was given a total discount of sh. 33300. If the discount on the price of a bag of rice was 2%, calculate percentage discount on the price of a bag of sugar.

**(2mks)**

20. (a) Using a ruler and a pair of compass only, construct a rhombus PQRS such that  $PQ=6\text{cm}$  and  $\angle PQR=135^\circ$  **(3 marks)**



- (b) Drop a perpendicular from R to meet PQ extended at N. Measure QN. **(2 marks)**
- (c) Bisect  $\angle PQR$  and  $\angle SPQ$  and let the two bisectors meet at M. Measure MP **(3marks)**
- d) Determine the area of triangle PQM. **(2marks)**



**21 (a)** On the grid provided, draw the square whose vertices are. A(6, -2), B(7, -2), C(7, -1) and D(6,-1). **(1mk)**

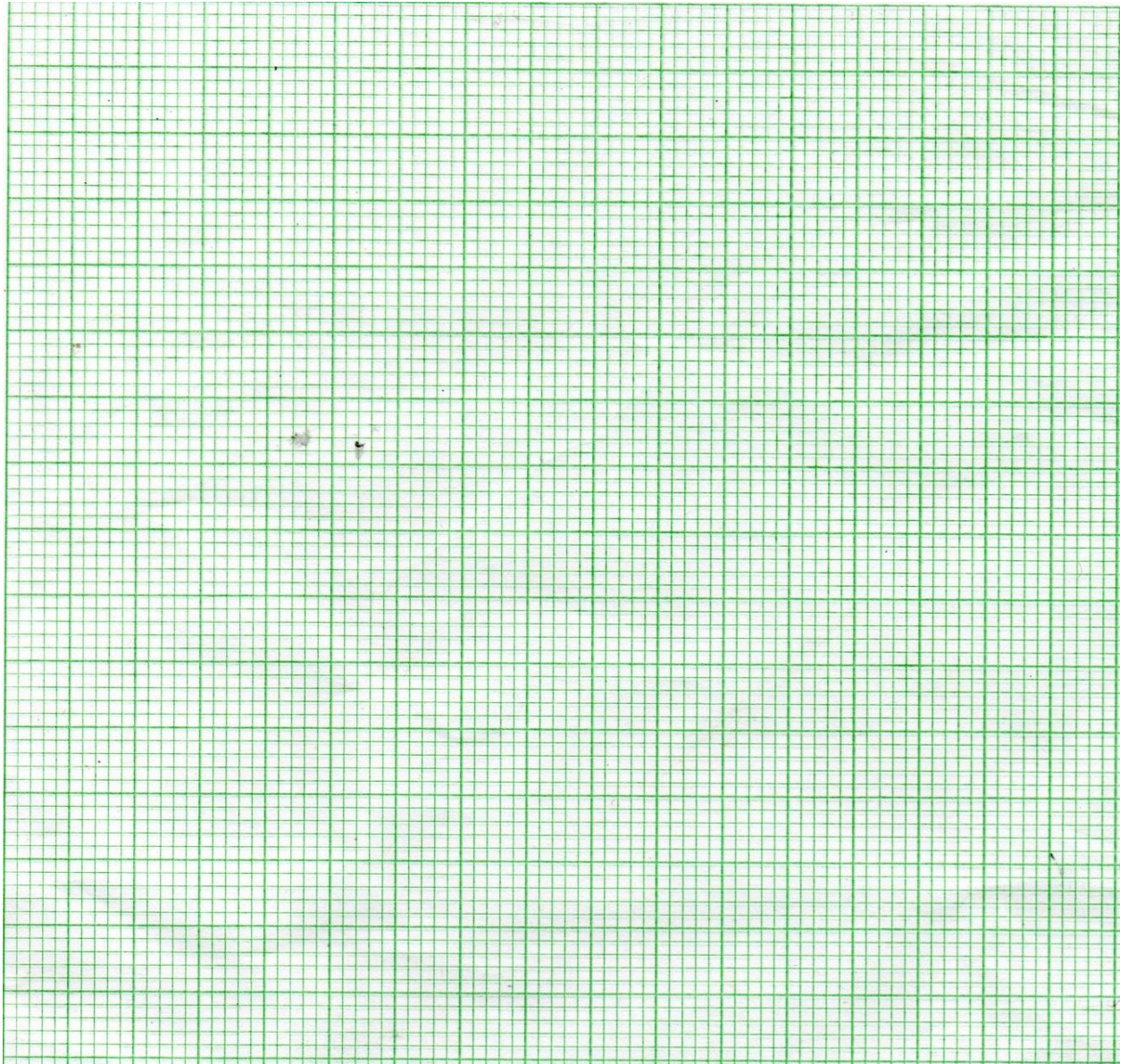

**(c)** On the same grid,

**i.** Draw A'B'C'D' the image of ABCD, under the enlargement scale factor 3, center (9, -4) **(3mks)**

- ii. Draw  $A''B''C''D''$  the image of  $A'B'C'D'$  under a reflection in the line  $X=0$   
(2mks)
- iii. Draw  $A'''B'''C'''D'''$  the image of  $A''B''C''D''$  under a rotation of  $+90^\circ$  about  $(0, 0)$   
(2mks)
- c) Describe a single transformation that maps  $A'B'C'D'$  onto  $A'''B'''C'''D'''$   
(2mks)

22. In the figure below, AD is a diameter of a circle center O. Angle  $FAD=64^\circ$ , angle  $EFD=30^\circ$ , angle  $ADB=50^\circ$  and the length  $AD=7\text{cm}$ .

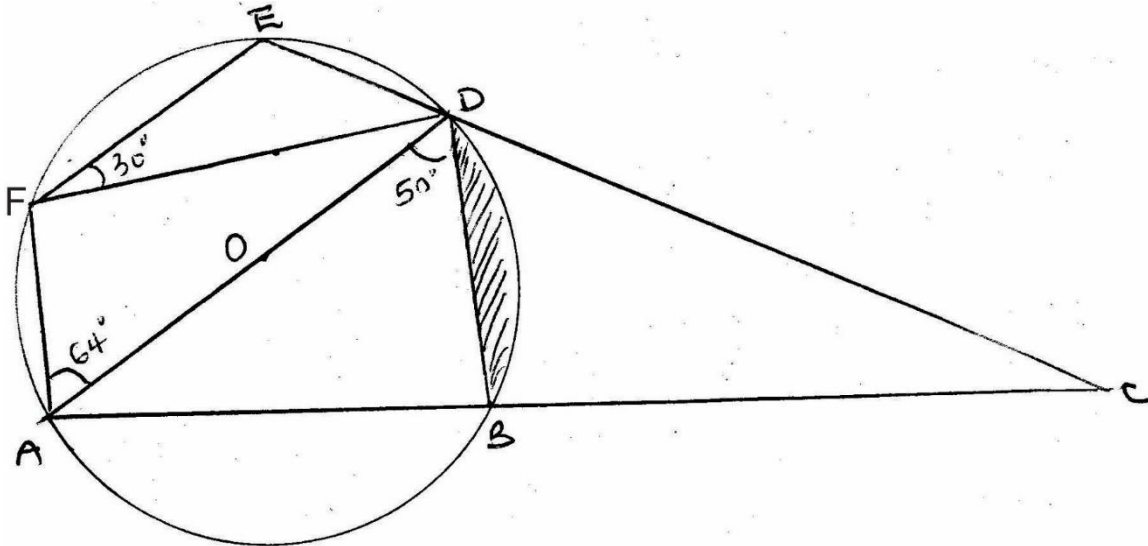

(a) Giving reasons, determine the size of the angles:

(i)  $\angle FED$

(2 marks)

**(ii)** DCB **(3 marks)**

**(iii)** Reflex EOB **(2 marks)**

**(b)** Determine the area of the shaded region. **(3 marks)**



23. The equation of a curve is  $y = 6x^2 - 12x - 18$

(a) Find;

(i) the x-intercepts of the curve.

**(3mks)**

(ii) the y- intercept of the curve

**(1mk)**

(b(i))Determine the stationary points of the curve

**(3mks)**

(ii)For the points in b (i) above, determine whether it is a minimum or a maximum point  
**(1mk)**

(c)Sketch the curve.

**(2mks)**



***KCSE Predictions Marking Schemes - 0707550000 / 0705525657***

24. Four towns R, T, K and G are such that T is 84km directly to the North of R and K is on a bearing of  $295^\circ$  from R at a distance of 60km. G is on a bearing of  $340^\circ$  from K and a distance of 30km.

Using a scale of 1cm to represent 10km, make an accurate scale drawing to show the relative positions of the towns. **(6 marks)**

(a) Use your diagram to find:

- (i) distance and bearing of T from K. **(2 marks)**

- (ii) distance and bearing of G from T. **(2 marks)**



# KCSE 2021 PREDICTION

NAME..... INDEX NO.....

SCHOOL..... SIGN.....

DATE.....

121/2

## MATHEMATICS

Paper 2

2 ½ HOURS

### Instructions to candidates

- Write your Name and Index number in the spaces provided above.
- The paper contains TWO sections: Section I and Section II.
- Answer ALL the questions in section I and **strictly any five** questions from Section II.
- All answers and working must be written on the question paper in the spaces provided below each question.
- Show all the steps in your calculations, giving your answers at each stage in the spaces below each question.
- Marks may be given for correct working even if the answer is wrong.
- Non-programmable silent electronic calculators and KNEC mathematical tables may be used, except where stated otherwise.
- Candidates should check to ascertain that all pages are printed as indicated and that no questions are missing.

For Examiner's Use Only

#### Section I

1	2	3	4	5	6	7	8	9	10	11	12	13	14	15	16	Total

#### Section II

17	18	19	20	21	22	23	24	Total

Grand Total





**SECTION I (50 MARKS)**

**ANSWER ALL QUESTIONS IN THE SPACES PROVIDED**

1. Without using logarithm tables or a calculator, solve the equation (3mks)

$$\log (5x - 4) = \log (x+ 2) + \frac{1}{3} \log 27$$

2. Make y the subject of the formula. (3mks)

$$T^2 = \frac{xy}{z+y}$$

3. A rectangular block has a square base whose side is exactly 8cm. Its height measured to the nearest millimetre is 3.1cm. Find in cubic centimetres the greatest possible error in calculating its volume (3mks)



4. Evaluate without using mathematical tables.

(3mks)

$$\frac{1.7 \times 0.042}{20 \times 0.0034}$$

5. Find the value of x in the equation.

(3mks)

$$16^{(x+2)} \times 8^{(x+3)} = 2^x$$



6. Njau, Juma and Kimindiri invested some money in the ratio 5:4:3 respectively. The business realized a profit of Sh 48,000. They shared 50% of the profit equally and the remainder in the ratio of their contributions. Calculate the total amount of money received by Kimindiri. (3mks)

7. A triangle PQR is such that PQ is 6CM and QR =8cm and  $\angle PQR = 60^\circ$ . Calculate :

i. The length of PR (2mks)



ii. The diameter of the circumcircle.

**(2mks)**

**8.** Simplify

$$\frac{5(\sqrt{11} - \sqrt{5}) - 4(\sqrt{11} + \sqrt{5})}{\sqrt{(11)^2} - \sqrt{(5)^2}}$$

**(3mks)**

**9.** Find the area bounded by the curve  $y = x^3 + 5$ , the  $x$  axis and lines  $x=1$  and  $x = 3$  **(3mks)**



**10.(a)** Expand  $(1 + 2x)^7$  up to the term in  $x^3$ .

**(2mks)**

**(b)** Hence use the expansion to estimate the value of  $(1.02)^7$  correct to four decimal places.

**(2 mks)**

**11.** A bag contains 2 green balls, 3 red balls and one blue ball. Another bag contains 4 green balls, 5 red balls and 3 blue balls. A ball is chosen at random from a bag. Find the probability that the chosen ball is blue. **(3mks)**



- 12.** P varies partly as the square of V and partly as the cube of V. When  $V = 2$ ,  $P = -20$  and when  $V = -3$ ,  $P = 135$ . Find the relationship between P and V. **(3mks)**

- 13.** The second term of a G.P is 6, and the fifth term is 48, find the common ratio and the 3<sup>rd</sup> term of the G.P. **(3mks)**

- 14.** The diagram below represents a field ABC.

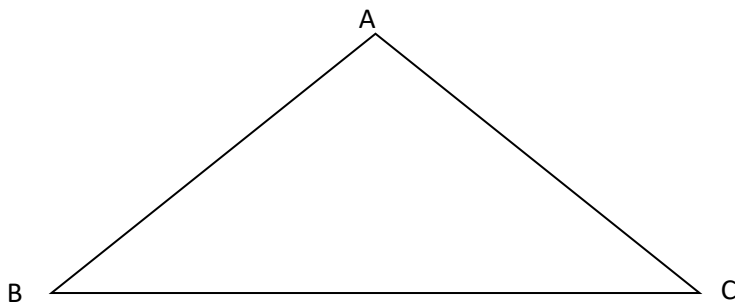

***KCSE Predictions Marking Schemes - 0707550000 / 0705525657***

a) Draw the locus of points equidistant from sides AB and AC **(1mk)**

b) Draw the locus of points equidistant from points A and C. **(1mk)**

c) A coin is lost within a region which is nearer to point A than to point C and closer to side AC than to side AB. Shade the region where the coin can be located. **(1mk)**

**15.** Nancy pays for a car on hire purchase in 15 monthly instalments. The cash price of the car is Ksh. 300,000 and the interest rate is 15% p.a. A deposit of Ksh 75,000 is made. Calculate her monthly repayments. **(4mks)**

**16.** Solve for  $\theta$  in the equation  $2 \sin (2\theta + 10) = -1$  for  $0 \leq \theta \leq 360^\circ$ . **(3mks)**



**SECTION II (50 MARKS)**  
**ANSWER ANY FIVE QUESTIONS IN THIS SECTION**

17. The table below shows Kenya Tax Rates in a certain year.

<b>Income</b> <b>(k£ per annum)</b>	<b>Tax Rate</b> <b>(Sh. Per £)</b>
1 – 1800	2
1801 – 3600	3
3601 – 5400	5
5401 – 7200	7

A married man earns sh. 6600 per month and is housed by the employer. The man is given benefits amounting to K£1200p.a for a car, school fees and medical fee. He is allowed a relief of K£ 48 p.a. for insurance and claims K£ 120 family relief p.a. Calculate:

(a) The man's annual taxable income in K£ (4mks)

(b) The monthly tax paid by the man in KSh. (6mks)





**18. (a)** Complete the table below to 2 decimal places.

(2mks)

X	$0^{\circ}$	$30^{\circ}$	$60^{\circ}$	$90^{\circ}$	$120^{\circ}$	$150^{\circ}$	$180^{\circ}$	$210^{\circ}$	$240^{\circ}$	$270^{\circ}$	$300^{\circ}$	$330^{\circ}$	$360^{\circ}$
$-\cos x$	-1		-		0.5	0.87		0.87			-0.5	0.87	
$\sin(x - 30^{\circ})$		0.0	0.5			0.87	0.5		-			-	-0.5

(b) Draw the graphs of  $y = \sin(x - 30^{\circ})$  and  $y = -\cos x$  on the same axes, for  $0^{\circ} \leq x \leq 360^{\circ}$ .

(5mks)

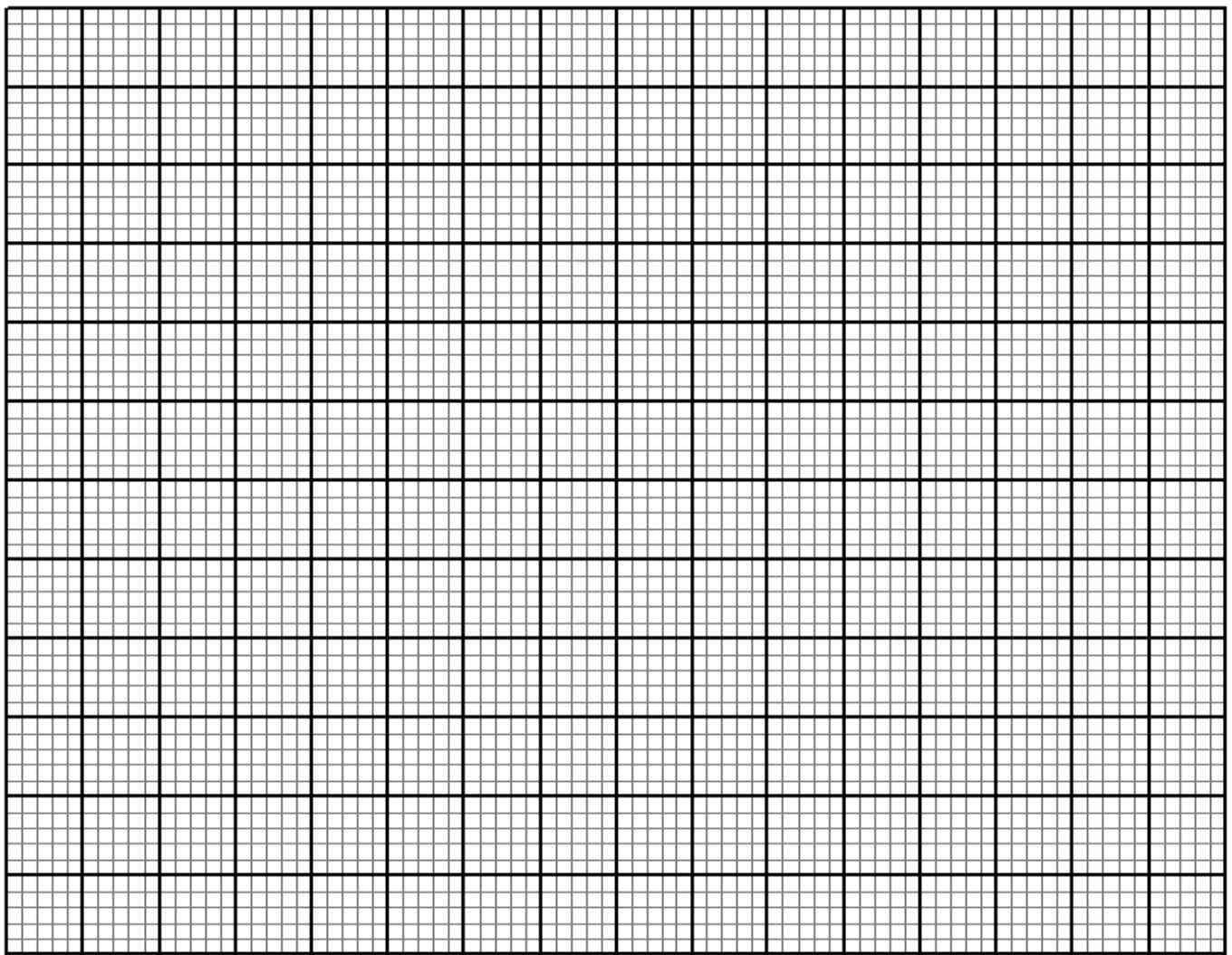

c) Use your graph to solve the equation  $\sin(x - 30^{\circ}) + \cos x = 0$ .

(3mks)



19. Figure below is a pyramid on a rectangular base.  $PQ=16\text{cm}$ ,  $QR = 12\text{cm}$  and  $VP = 13\text{cm}$ .

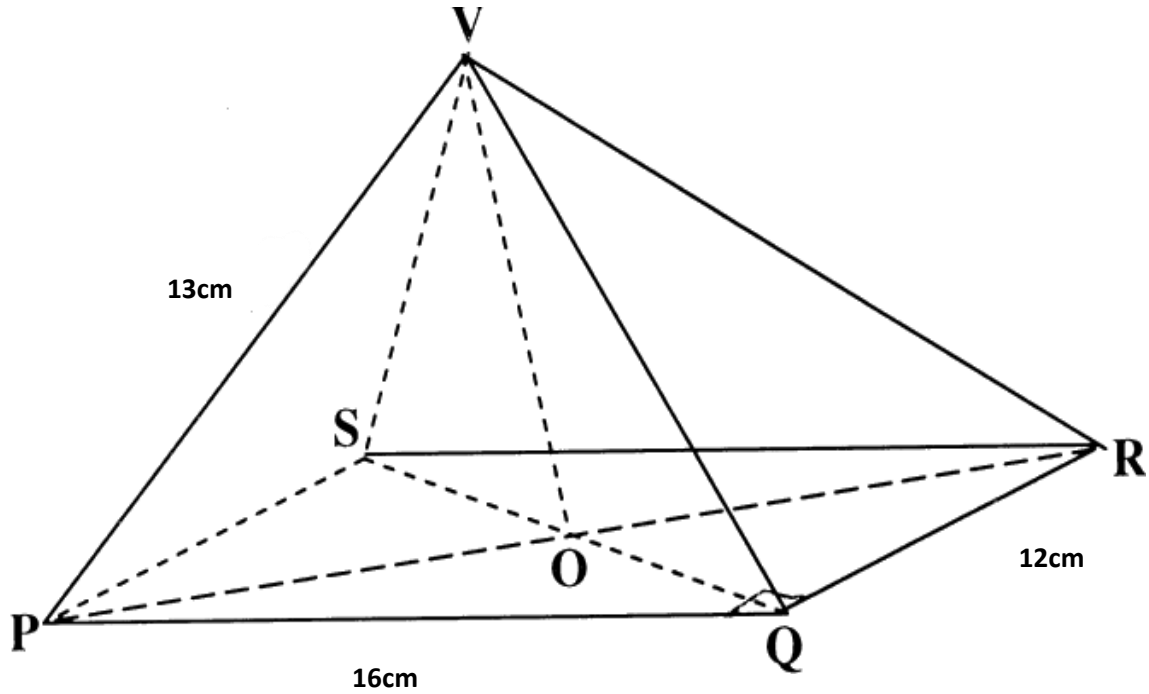

Find

- (a) The length of **QS**. (2mks)
- (b) The height of the pyramid to 1 decimal place. (2mks)
- (c) The angle between **VQ** and the base. (2mks)
- (d) The angle between plane **VQR** and the base. (2mks)
- (e) The angle between planes **VQR** and **VPS** (2mks)



**20.** The following table shows the distribution of marks obtained by 50 students in a test.

Marks	45 – 49	50 – 54	55 – 59	60 – 64	65 – 69	70 – 74	75 – 79
No. of students	3	9	13	15	5	4	1

By using an assumed mean of 62, calculate

**(a)** the mean

**(5mks)**

**(b)** the variance

**(3mks)**

**(c)** the standard deviation

**(2mks)**



***KCSE Predictions Marking Schemes - 0707550000 / 0705525657***

21. The velocity of a particle is given as  $V = 12t - 2t^2$ .

a) Determine the distance travelled by the particle in terms of  $t$  if the distance is 6 meters when  $t = 1$ .  
**(3mks)**

b) Determine the distance moved by the particle between  $t = 2$  and  $t = 3$ .  
**(2mks)**

c) Calculate the maximum distance moved by the particle.  
**(3mks)**

d) Determine the acceleration after 2 seconds.  
**(2mks)**



22. Triangle ABC has vertices A(1,1) ,B(3,1) and C (3,3).

a) On the grid provide draw triangle ABC.

**(1mk)**

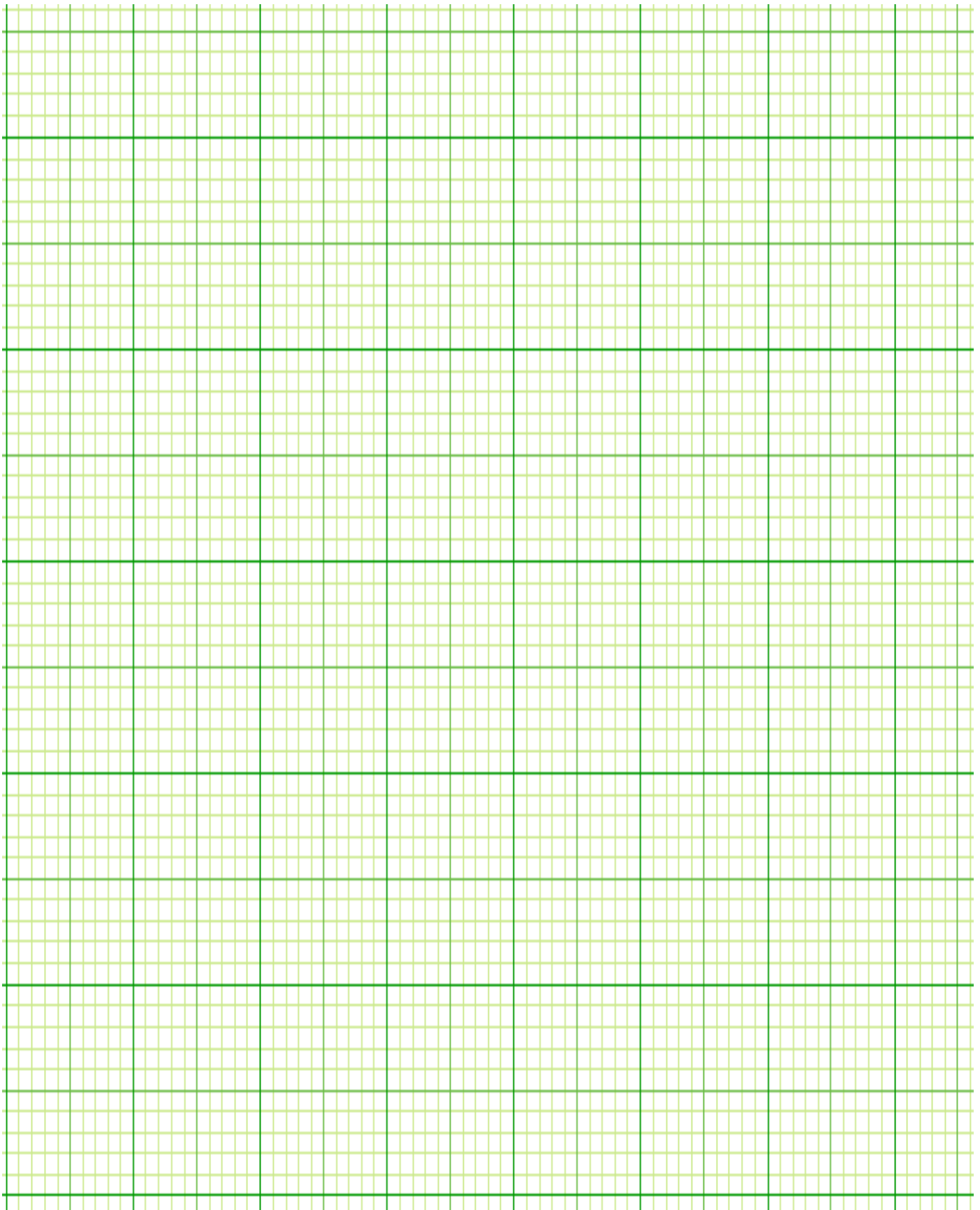

***KCSE Predictions Marking Schemes - 0707550000 / 0705525657***

b) A'B'C' is the image of  $\Delta ABC$  under positive quarter turn about the origin. On the same grid. Draw the image of triangle A'B'C'. **(2mks)**

c) A''B''C'' is the image of A'B'C' under transformation given by the matrix.  $\begin{pmatrix} 1 & -2 \\ 0 & 1 \end{pmatrix}$

i. Determine the co-ordinates of A''B''C''. **(2mks)**

ii. On the same grid draw the triangle A''B''C''. **(1mk)**

d) Find the object area hence determine the area of the final image. **(2mks)**



23. In the figure below  $\vec{OA}$  is  $\underline{a}$  and  $\vec{OB}$  is  $\underline{b}$  M is the mid point  $\vec{OA}$  and AN :AB 3:1

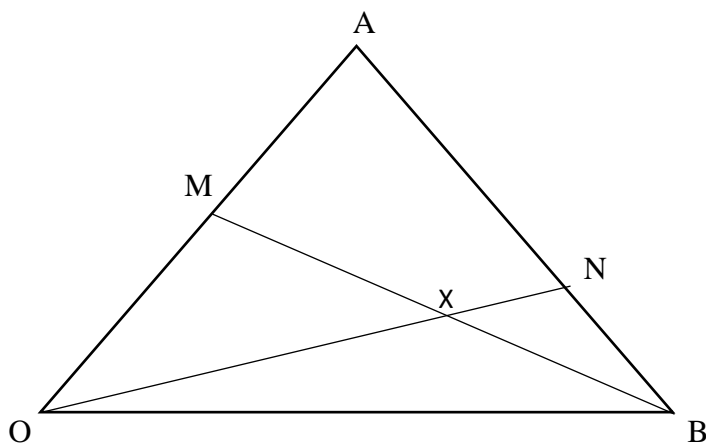

a) Express in terms of a and b

i.  $\vec{AB}$  **(1mk)**

ii.  $\vec{AN}$  **(1mk)**

iii.  $\vec{ON}$  **(1mk)**

b) Given that  $\vec{BX} = h \vec{BM}$  and  $\vec{OX} = k \vec{ON}$  determine the values of h and k. **(6mks)**



**KCSE Predictions Marking Schemes - 0707550000 / 0705525657**

24. A manager wishes to hire two types of machine. He considers the following facts.

	<u>Machine A</u>	<u>Machine B</u>
Floor space	$2\text{m}^2$	$3\text{m}^2$
Number of men required to operate	4	3

He has a maximum of  $24\text{m}^2$  of floor space and a maximum of 36 men available. In addition he is not allowed to hire more machines of type B than of type A.

(a) If he hires  $x$  machines of type A and  $y$  machines of type B, write down all the inequalities that satisfy the above conditions. **(4mks)**

(b) Represent the inequalities on the grid and shade the unwanted region. **(4mks)**

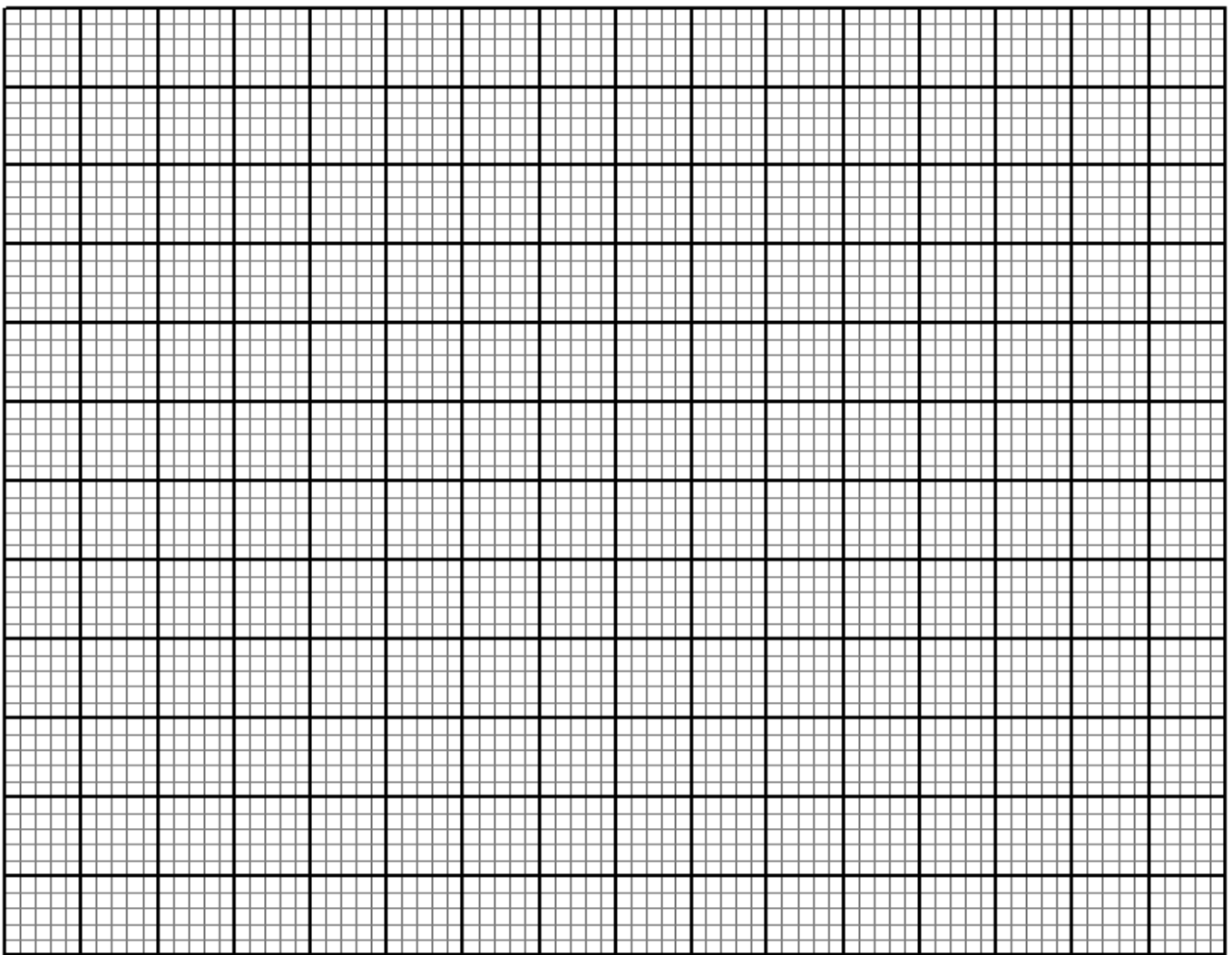

c) If the profit from machine A is Ksh. 4 per hour and that from using B is Ksh. 8 per hour. What number of machines of each type should the manager choose to give the maximum profit? Calculate the maximum profit obtained. **(2mks)**





# KCSE 2021 PREDICTION

NAME..... INDEX NO.....

SCHOOL..... SIGN.....

DATE.....

## ENGLISH

(FUNCTIONAL WRITING, CLOZE TEST AND ORAL SKILLS)

TIME 2 HOURS

### INSTRUCTIONS

- (a) Write your **name and admission number** in the spaces provided above..
- (b) Answer **all** questions in this question paper.
- (c) Answers to **all** questions **must** be written in the spaces provided in this booklet.
- (d) Candidates should check to ascertain that all pages are printed as indicated and that no questions are missing.
- (e) Candidates should answer all the questions in English

### For Examiner's Use Only

QUESTION	MAXIMUM SCORE	CANDIDATE'S SCORE
1	20	
2	10	
3	30	
<b>TOTAL SCORE</b>	60	



**FUNCTIONAL WRITING (20 MKS)**

You are the manager in Jungu Kuu Fruits Company. You suddenly learn that one of your employees in your company has passed on in a fatal road accident.

- a) Write a memo to inform all the other employees of the news and remind them to contribute funds towards giving the deceased a good send off. (12 mks)**

.....

.....

.....

.....

.....

.....

.....

.....

.....

.....

.....

.....

.....

.....

.....

.....

.....

.....

.....

.....

.....

.....

.....

.....

.....

.....

.....

.....



*KCSE Predictions Marking Schemes - 0707550000 / 0705525657*

.....

.....

.....

.....

.....

.....

.....

.....

.....

.....

.....

.....

.....

.....

.....

.....

.....

.....

.....

.....

.....

.....

.....





*KCSE Predictions Marking Schemes - 0707550000 / 0705525657*

.....

.....

.....

.....

.....

.....

.....

.....

.....

.....

.....

.....

.....

.....

.....

.....

.....

.....

.....

.....



**CLOZE TEST (10 marks)**

**Read the passage below and fill in each blank space with the most appropriate word.**

Cigarette smoking is one of the major causes of death (1)..... adults and teenagers both in developed and developing countries. Unfortunately, very little has been done to educate these product (2)..... on the dangers of smoking. Smoking has adverse (3)..... especially if one smokes more than one pack a day, or has smoked for a long time. The full extent of smoking on one’s body (4)..... from person to person, since it depends on the person’s vulnerability to the chemical in the cigarette or tobacco smoke. The effects also vary depending (5)..... the number of cigarette sticks a person smokes (6)..... day, the age when the person started to smoke and the number of years the person has (7)..... smoking. Recent studies further indicate (8)..... every year hundreds of thousands of people from all corners of the world die from medical complications caused by smoking. Apart from causing death, cigarette smoking is(9)..... by a couple of complications, which include: a rise in a person’s blood pressure, heart rate, decrease in a person’s blood flow to body extremities like the finger and toes, dizziness ,nausea, watery eyes, hyper acidity, loss (10)..... taste, smell and loss of appetite.

**ORAL SKILLS (30 Marks)**

**Read the following oral poem and answer the questions that follow.**

**(10 mks)**

**There was a little man**

There was a little man  
And he had a little gun  
And his bullets were made of Lead, Lead, and Lead  
He went to the brook  
And he saw a little duck  
And he shot it right through the head, head, and head.

He carried it home  
To his old wife, Juan  
And lit her fire to make, make, make  
To roast the little duck  
He had shot in the brook  
And he’d gone and fetched her the drake, drake, drake.



The drake was swimming with his curly tail,  
The old man made his mark, mark, mark  
He fired his shot  
But he fired too soon,  
And the drake flew away with a quack, quack, quack.

**Questions**

1. Identify and illustrate how rhythm has been achieved in this oral poem **(3 marks)**

.....

.....

.....

.....

.....

.....

.....

2. Imagine you are performing this poem to learners who are visually impaired. Explain three ways in which you would ensure that they get the message effectively. **(3 marks)**

.....

.....

.....

.....

.....

.....

.....



3. If you are performing this poem, to an audience, in which ways would you enliven your presentation? **(4 marks)**

.....

.....

.....

.....

.....

.....

.....

B) Identify the silent letters in the following words **(3 marks)**

- i) Baguette
- ii) Poignant
- iii) Succumb

C) Pick the odd one out according to the pronunciation of the underlined letters. **(4marks)**

- i) Sachet                      researcher                      machete                      machine
- ii) Fundamental                      Pulley                      Mundane                      Bungalow
- iii) Aunt                      August                      Author                      Authority
- iv) Salt,                      insult                      sum                      Luck

D) State whether you would end with a rising or falling intonation against each of the following sentences **(3marks)**

- i) What an awesome sight!
- ii) I have a riddle, are you ready to take it?
- iii) Are you going to the meeting?

E) You are attending a debate club in your neighboring school. When a student from your school takes the podium, you notice that he/she is afraid. Write down two indicators that would tell you that the student is anxious and suggest how to overcome them. **(4 marks)**

.....

.....

.....





.....

.....

.....

.....

.....

.....

F) During the prize giving day, you have been asked to present a narrative to the guests. State any three ways in which you would make your story interesting. **(3 marks)**

.....

.....

.....

.....

.....

.....

G) The school’s dining hall roof has been destroyed and is under renovation following a heavy downpour. Students have been requested to take their meals in a makeshift structure as construction is being completed. On two occasions, four students have been pushing, jostling and edging out from others as they demand to be considered in the first eating shift. As a dining hall captain, you are called to arbitrate the case. As a good negotiator, what three aspects would you consider as you try to reach an agreement? **(3 marks)**

.....

.....

.....

.....

.....

.....



# KCSE 2021 PREDICTION

NAME..... INDEX NO.....

SCHOOL..... SIGN.....

DATE.....

101/2

## ENGLISH

Paper 2

(COMPREHENSION, LITERARY APPRECIATION AND GRAMMAR)

2 ½ HOURS

### Instructions to candidates

- (a) Write your **name**, **index number** and the **name** of your school in the spaces provided above.
- (b) **Sign** and write the **date** of examination in the spaces provided above.
- (c) Answer **all** questions in this question paper.
- (d) Answers to **all** questions **must** be written in the spaces provided in this booklet.
- (e) **Candidates should check to ascertain that all pages are printed as indicated and that no questions are missing.**
- (f) **Candidates should answer all the questions in English**

### For Examiner's Use Only

QUESTION	MAXIMUM SCORE	CANDIDATE'S SCORE
1	20	
2	25	
3	20	
4	15	
<b>TOTAL SCORE</b>	80	



## **1. COMPREHENSION**

### **1. Read the passage below and then answer the questions that follow.**

A lot of students think that learning is only in class. If students use two extra steps, most students will not forget what they learned in class. To achieve effective learning, students need to follow two extra steps in the three strategic learning processes.

The key to success is by following these three strategies. Review is essential to student success. Unless content is reviewed by students shortly after it is learned, it will soon be forgotten. To avoid forgetting what you learned, it is recommended to review daily.

It is also recommended to reduce large volumes of notes into point form and to paraphrase what you have learned. Other helpful tips include creating concept maps and diagrams; creating fact, concept or vocabulary cards and using visualization to better connect to what you learned. These are all important tools to helping students better understand and memorize lesson content.

The key to achieving academic success cannot be directly **correlated** to one specific area. Rather it requires students to be overall rounded in many different aspects. This includes attending class regularly to keep pace with the class. Falling behind in studies or homework can be **detrimental** to academic success and can induce stress onto students. Participating in class activities and discussions are also vital parts of learning and applying concepts learned. On the other hand, taking good, concise notes will always help in the long run when reviewing for tests and exams. To sum it all up, strategic learning is the password for many academic achievements. Being exposed to knowledge is the first step in the journey, the fact that young scholars can learn and be a part of history is a phenomenal step in furthering their search to success. Reviewing notes, in the way the young individual wishes, by him/herself, or with a good friend, this will help him/her to understand what has been learned in a way he/she understands. Lastly practice is a great way to memorise what has been learned, when practice achieves its full potential, the individual won't only be entitled for a good mark, but also a way to view, under and think of things. Those three attributes will help scholars become more successful, but it's important to one as it is to the other, and each and every person should find the learning strategies **effectual** for him/herself, and in extremely **exceptional** occasions even invent or innovate new strategies.

### **Questions**

(a) What does the writer faults in the students thinking according to the first paragraph?(2 marks)

.....



.....  
.....  
(b) Explain the **three** strategies that are key to success. (6marks)

.....  
.....  
.....  
.....  
.....  
.....  
.....  
.....  
.....  
.....  
.....

(c) Unless content is reviewed by students shortly after it is learned, it will soon be forgotten.. (1 mark)

*Begin: if.....*

.....  
.....  
.....

(d) The key to achieving academic success cannot be directly **correlated** to one specific area.. (1mark)

*Add a question tag.*

.....  
.....

(e) Discuss the tone of the passage. (3 marks)

.....  
.....  
.....



.....  
(f) How, according to the passage, does practice help memorise what has been learned?

(3marks)

.....  
(g) Explain the meaning of the following words and phrases are used in the passage. (4marks)

Detrimental.....

Correlated.....

Effectual.....

Exceptional.....

**2. Read the following passage and answer the questions that follow.**

**Krogstad:** No matter about that.

**Nora:** What do you want of me?

**Krogstad:** An explanation of something.

**Nora:** Make haste them. What is it?

**Krogstad:** You know, I suppose, that I have got my dismissal.

**Nora:** I couldn't prevent it, Mr. Krogstad. I fought as hard as I could on your side, but it was no good.

**Krogstad:** Does your husband love you so little, then? He knows what I can expose you to, and yet ventures-

**Nora:** How can you suppose that he has any knowledge of the sort?

**Krogstad:** I didn't suppose so at all. It would not be the least like our dear Torvald Helmer to show so much courage-



**Nora:** Mr. Krogstad, a little respect for my husband, please.

**Krogstad:** Certainly — all the respect he deserves, but since you have kept the matter so carefully to yourself. I make bold to suppose that you have a little clearer idea, than you had yesterday, of what it actually is that you have done?

**Nora:** More than you could ever teach me.

**Krogstad:** Yes, such a bad lawyer as I am.

**Nora:** What is it you want of me?

**Krogstad:** only to see how you were, Mrs Helmer, I have been thinking about you all day long. A mere cashier, a quill driver, a man like me - even he has a little of what is called feeling, you know.

**Nora:** Show it, then; think of my little children.

**Krogstad:** Have you and your husband thought of mine? But never mind about that. I only wanted to tell you that you need not take this matter too seriously. In the first place there will be no accusation made on my part.

**Nora:** No, of course not; I was sure of that.

**Krogstad:** The whole thing can be arranged amicably; there is no reason why anyone should know anything about it. It will remain a secret between us three.

**Nora:** My husband must never get to know anything about it.

**Krogstad:** How will you be able to prevent it? Am I to understand that you can pay the balance that is owing?

**Nora:** No, not just at present.

**Krogstad:** Or perhaps that you have some expedient for raising the money soon?

**Nora:** No expedient that I mean to make use of.

**Krogstad:** Well, in any case, it would have been of no use to you. Now if you stood there with ever so much money in your hand, I would never part with your bond.

**Questions**

a) Place this excerpt in its immediate context.

**(4marks)**

.....

.....

.....

.....

.....



.....

**b) What is Krogstad's attitude towards Helmer? Explain. (3marks)**

.....  
.....  
.....  
.....  
.....

**c) "You have some expedient for raising the money soon". Does Nora have an idea on how to raise the money? Explain (4marks)**

.....  
.....  
.....  
.....  
.....  
.....  
.....  
.....  
.....  
.....

**d) "Yes, such a bad lawyer as I am". What is the tone of this statement? (2mks)**

.....  
.....  
.....  
.....



e) "Does your husband love you so little then?" How does Helmer's behavior later in the play bear out Krogstad' statement? **(4marks)**

.....

.....

.....

.....

.....

f) Describe Krogstad’s character as revealed in this excerpt **(4marks)**

.....

.....

.....

.....

.....

g) Identify and explain the use of irony in this excerpt. **(2mks)**

.....

.....

h) A mere cashier, a quill driver a man like me even he has a little of what is called feelings you know. (Rewrite beginning: Even .....)  
**(2 marks)**

.....

.....

.....

**3. Read the following narrative and answer the questions that follow.**

**An Old Woman and her Deformed Son**

There was an old woman whose children died in infancy and only a deformed boy survived to grow into adulthood. The boy was a hunchback.





## ***KCSE Predictions Marking Schemes - 0707550000 / 0705525657***

Although the old woman loved this hunchback son of hers, she was secretly ashamed of his physical appearance. She was so ashamed that each day she was on the look – out for visitors who might come around just to make fun of him. To keep him away from the public eye, she used to confine him in a drum most of the time. So, right from his childhood the boy grew up in a drum. He was taken out only a few times during the day when the old woman was sure that there were likely to be no intruders around. When the boy attained circumcision age, he was duly circumcised. After circumcision he said to the old woman, “Mother, I now want a wife, can you please find me a girl to marry!” “Yes, my son”, said the old woman. “I will try. I am indeed very pleased to learn that you are already thinking of a wife.”

By and by, the old woman went to look for a suitable girl to marry her son. She approached a pretty girl and asked her whether she would be interested in marrying her son and the girl, promised to think about it. Without disclosing her son’s physical defects to the girl, the old woman set about wooing her intensively. She brought all sorts of gifts to her mother, helped the girl to collect firewood and even helped her with the work in the shamba. Reluctantly the girl gave in and there upon requested the old woman to make the necessary arrangements so that she would meet the future husband. The old woman cunningly suggested that the girl should accompany her to her house where she would be able to meet the boy.

The old woman lived a long way from the girl’s village. On the day when the girl decided to visit her prospective bridegroom, she walked and walked until sunset. It was a very long journey indeed. When she eventually arrived, the old woman pretended that the young man was around and would appear shortly. The girl waited and waited but the boy did not appear at all. At bed time the girl was told that the boy was already in bed sleeping. She was shown a separate place to sleep, and thus no opportunity to either see or talk to the boy as would have been expected of people who were planning to live together. Very early in the morning the girl asked the old man, “ Please, where is the boy you want me to marry?” and the woman replied, “ My son woke up early in the morning and went to work in a different village yonder so that he can earn something for your bride price”

Although the girl was visibly disappointed, she tried to conceal her sentiments and appear to be at home with everything around the house. The old woman and the girl went to cultivate in a banana grove. While they were away the boy jumped out of the drum and busied himself about the house with the little chores singing:



*Khanenuya munju, mwange, Khanenuye munju mwange*

*Mkhasi nakikhali misilu, maji kakuombelesay musecha kacha*

*Khuema, abele khuchuma nacha sina?*

*Menyile, mukhang'oma, kurumba kuli khumukongo*

*(Let me busy myself in my house. Aren't women foolish? Mother fooled her. "Your husband has gone to work." How could I have gone to work? I just live in my little drum because I have a hunchback.)*

The girl heard the boy's singing but it was so faint that she would neither comprehend the meaning of the song nor even make out as to which direction the sound came from. However, out of curiosity she stopped from time to time and listened. This went on for several days until she started to guess the meaning of the words in the song. On getting the message home, she was quite disturbed. Her suspicion was strengthened by the fact that each morning they left for the shamba without sweeping or washing utensils but on their return they found everything tidy about the house. One day she deceived the old woman by telling her that she was going to attend to the call of nature while in fact her intention was to discover the house and stood listening keenly at the door. She got really upset with the boy's derogatory song. She pondered with herself, "So this is my husband to be? A hunchback confined to a drum? No wonder the old woman deceived me the way she did. What girl in proper senses could marry a man like that? Anyway what can I do now? I must put an end to this continued bluff...."

One morning she said to the old woman, "Mother, today will you go to look for firewood while I go to the plantation alone?" The old woman said, "Yes, my daughter, we can share work that way." She had grown so used to the cheerful and friendly manner of the girl, thinking that she would not mind staying on as her daughter – in law even after discovering that her son was deformed. Indeed she was already contemplating making the revelation to her.

And so each went her separate way. But as soon as the old woman vanished from sight the girl dashed back and stood at the door which had now become a familiar ground for spying on the hunchback. She listened briefly as the boy sang mischievously inside the house. Then she stole a quick glance peeping through a side hole.

To her amazement, she saw that he was a real hunchback! Quite oblivious, the boy went on sweeping the floor and singing. The girl felt that she could no longer stand it. She broke into the house



suddenly with the intention of beating up the mischievous fellow. But before she could get hold of him he dodged nimbly and slipped back into the drum. Nonetheless, the girl fuming with anger picked up the drum and smashed it on the floor. A pool of blood started oozing from the broken drum. The poor hunchback was dead.

Considering it appropriate revenge on the old woman the girl felt no remorse for the action she had taken. She rolled over the cold body of the hunchback as a lump of anger swelled up in her throat. When the old woman returned home and found the mess she had done in the house she screamed at the top of her voice, “ Ooh , oh... Uuuuwee... Uuuuweeeeee!” But it was all in vain. The deformed boy whom she had been ashamed of showing to the public was dead and gone forever! Yes, instead of feeling relieved by the burden of shame she now felt great anguish for this loss. After killing the hunchback the girl also disappeared never to be seen again. The poor old woman remained there weeping and feeling quite forlorn.

**Questions**

(a) Place this narrative in its correct genre .. **(1mk)**

.....  
.....

(b)How is the old woman to blame for the tragedy that befell her? **(1mk)**

.....  
.....

(c) Identify **two** socio – economic activities in the community. Support your answer with the evidence from the story. **(4mks)**

.....  
.....  
.....  
.....



**(d)** What is the role of the song in the narrative?

**(2mks)**

.....

.....

.....

.....

**(e)**With illustrations, describe the character of:

**(4mks)**

**(i)** The girl

.....

.....

.....

.....

**(ii)** The old woman

.....

.....

.....

.....

**(f)** Explain **two** features typical of oral narratives present in this story.

**(4mks)**

.....

.....

.....

.....

.....

.....

.....



(g) Identify and illustrate any **two** moral lessons we learn from this narrative **(4mks)**

.....

.....

.....

.....

.....

**5. GRAMMAR (15 MARKS)**

**1.** Rewrite the following sentences according to the instructions given after each without changing the meaning. **(4 marks)**

a.) He submitted his poem for publication after being encouraged by his friends. (Begin: Encouraged...)

b.) Mother asked Mutiso if he would make breakfast the following day.(Change to direct speech)

c.) But for the pilot's quick action, the plane would have crashed. ( Begin: Had it ...)

d.) My brother and me have been taking violin lessons for two months. (Rewrite the sentence correctly. )

**2.** Fill in the blank spaces with the correct form of the word in bracket. **(4 marks)**

a.) He \_\_\_\_\_ visits his grandparents. (often)

b.) Our roads are being renovated to increase their \_\_\_\_\_. (wide)



c.) The party rebels were \_\_\_\_\_ subjected to bombarding from the party leaders. (relent)

d.) Men are not expected to show signs of \_\_\_\_\_ . (coward)

**3.** In each of the following sentences, give an appropriate phrasal verb that means the same as the underlined word. **( 3 marks)**

a.) The thief confessed after a thorough beating by the irate mob.

b.) The grandmother liked her grandchildren .

c.) The meeting was cancelled at the eleventh hour.

**4.** Fill in the blank spaces with an appropriate preposition. **( 3 marks)**

a.) The new student was so confused that he was lost \_\_\_\_\_ words.

b.) My father deals \_\_\_\_\_ second-hand clothes.

c.) John is very good \_\_\_\_\_ English.

**5.** Rewrite the following sentence correctly. ( 1 mark)

a.) I went for shopping yesterday.

**THIS IS THE LAST PRINTED PAGE.**



# KCSE 2021 PREDICTION

NAME..... INDEX NO.....

SCHOOL..... SIGN.....

DATE.....

101/3

## ENGLISH

Paper 3

(ESSAY BASED ON LITERARY TEXTS)

2 ½ HOURS

### Instructions to candidates

- (a) Write your **name**, **index number** and the **name** of your school in the spaces provided above.
- (b) **Sign** and **write the date** of examination in the spaces provided above.
- (c) Answer **all** questions in this question paper.
- (d) Answers to **three** questions **must** be written in the spaces provided in this booklet.
- (e) Candidates should check to ascertain that all pages are printed as indicated and that no questions are missing.
- (f) Candidates should answer three questions in English

For Examiner's Use Only

QUESTION	MAXIMUM SCORE	CANDIDATE'S SCORE
1	20	
2	20	
3	20	
<b>TOTAL SCORE</b>	60	



**1. Creative Composition.**

**(2 marks)**

**Either**

Write a composition ending with the following statement

a) .....a final look at her made me realize that choices have consequences.

**Or**

b) Write a composition expressing the validity of the saying: Let sleeping dogs lie.

**2. Novel (Compulsory)**

**(20 marks)**

“Selfish interest is a vice that whoever engages in it is bound to fail. Using Blossoms of The Savannah, write an essay to support the assertion.

**3.**

Either

**a) Short-story**

**Wanjala Chris (Ed): Memories we lost and other stories (20mrks)**

The greatest casualties of any civil war are the civilians. Write an essay in support of the above assertion drawing your illustrations from Mariatu Kemara’s ‘ The president’

Or

**b) Drama**

**David Mulwa: Inheritance**

Artistically, David Mulwa has criticized the folly of poor leadership in any given society. Using his text the Inheritance, write an essay to validate this statement.

Or

**c) The novel**

**John Steinbeck: The Pearl**

Drawing your illustrations from John Steinbeck’s The Pearl, write a composition that portrays man as helpless in a fateful world.

**THIS IS THE LAST PRINTED PAGE.**





# KCSE 2021 PREDICTION

NAME..... INDEX NO.....

SCHOOL..... SIGN.....

DATE.....

102/1

## KISWAHILI

Paper 1

KARATASI YA 1 - INSHA

MUDA SAA 1  $\frac{3}{4}$

### MAAGIZO

- (a) Andika insha mbili, insha ya kwanza ni lazima
- (b) Kisha chagua insha nyingine moja kati ya hizo zilizobakia tatu.
- (c) Kila insha isipungue maneno 400
- (d) Kila insha ina alama 20
- (e) Kila insha **LAZIMA** iandikwe kwa lugha ya Kiswahili
- (f) Karatasi hii ina kurasa mbili zilizopigwa chapa.
- (g) Watahiniwa ni lazima wahakikishe kwamba kurasa zote za karatasi hii zimepigwa chapa sawasawa na kuwa maswali yote yamo.



**LAZIMA**

1. Suala la kuzorota kwa usalama nchini kenya limekuwa donda ndugu. Andika mahojiano kati ya waziri wa usalama wa kitaifa na mwandishi wa habari kuhusu chanzo na mbinu za kukabiliana na janga hili
2. Ufisadi ndicho kikwazo kikuu cha maendeleo hapa nchini. Eleza
3. Andika kisa kinachodhibitisha ukweli wa methali.

***Jifya moja haliijiki chungu***

4. Andika insha itakayomalizikia kwa maneno; ***...nilitamani ardhi ipasuke nitumbukie huko nisione kane.***



# KCSE 2021 PREDICTION

NAME..... INDEX NO.....

SCHOOL..... SIGN.....

DATE.....

102/2

## KISWAHILI

Karatasi ya 2

(Ufahamu, ufupisho, Sarufi na matumizi ya lugha na Isimu jamii)

MUDA SAA 2 ½

### MAAGIZO

- Andika jina na nambari yako kwenye nafasi ulizoachiwa hapo juu.
- Tia sahihi yako kisha uandike tarehe ya mtihani.
- Jibu maswali yote.
- Andika majibu yako katika nafasi ulizoachiwa katika kijitabu hiki cha maswali.
- Majibu yako yaandikwe kwa lugha ya kiswahili

#### KWA MATUMIZI YA MTAHINI PEKEE

SWALI	ALAMA	TUZO
1	15	
2	15	
3	40	
4	10	
JUMLA	80	



**SEHEMU YA A: UFAHAMU**

**(alama 15)**

**Soma taarifa ifuatayo kisha ujibu maswali**

“Swala la idadi kubwa ya watoto wadogo wanaoendelea kumiminika mijini na kuonekana wakirandaranda mijini ovyo,halijapewa umuhimu wowote wa haja na serikali za nchi nyingi,liche ya mijadala katika warsha anuwai,zilizofanyika kujadili swala hili nyeti.

Kwa kutokuwa na sheria ama sera iliyo wazi kuhusu haki na usalama wa watoto,sarikali zetu hazina budi kukubali kubeba uzito wote wa lawama. Hii ni kwa sababu, serikali zetu zimelipuuza na kuvalia miwani swala hili kwa kuchukulia kuwa litapotea lenyewe katika hewa yabisi. Yafaa ifahamike kuwa usalama wetu katika siku zijazo utategemea jinsi tutakavyolikabili ana kwa ana tatizo hili wakati huu. Wakati wa kutenda ni sasa. Aidha, watoto hawa wanaokulia mitaani bila malezi,maelekezo wala mwongozo mwafaka wa kimaisha, wanakua bila mapenzi hivyo hawajui maana ya kupenda. Wanachokijua ni chuki na haja ya kulipiza kisasi dhidhi ya jamii iliyowachonga jinsi walivyo. Hawajali lolote hata kifo. Wako tayari kujikabidhi kwa haini yeyote mwenye nia mbaya,bila kujali matokeo, muradi tu, wapate riziki.

Tunapendekeza kwa serikali, washirika dau kama vile mashirika ya kujitolea, viongozi wa dini, shule, vyuo na wananchi kwa jumla wachange bia katika kutafuta mikakati ya kulitatu tatizo hili kabla halijageuka kuwa janga la kijamii ambalo tutashindwa kulimudu. Mpango wa vijana hawa kujiunga na huduma ya taifa ni jambo linalofaa kutiliwa maanani.

Tunapendekeza makao Zaidi ya watoto wanaozurura mijini yajengwe ambapo watapata mafunzo ya kiufundi yatakayowawezesha kujitegemea maishani. Badala ya kulitegea mgongo swala hili, serikali zinawajibika kuwasajili hawa watoto ili waweze kuunganishwa na familia na koo zao. Utafiti uliofanywa na wataalamu wa Elimu jamii umebainisha kuwa ni asilimia kumi tu ya watoto hawa wa mitaani wasiokuwa na mahali wawezapo kupaita nyumbani. Asilimia tisini iliyobaki, angalau wana mahali wanapoweza kupaita nyumbani ilhali wanaendelea kuwa mitaani. Wazazi tumesahau wajibu wetu. Wengi wetu tumelikimbia jukumu la ulezi tulilopewa na muumba. Hawa waliojipaka masizi mwilin mzima, wanaozurura ovyo mitaani, si matokeo ya maumbile;hawakuja duniani kwa sadfa, hawakuulizwa wala kushauriwa. Makosa ni yetu wazazi. Tuliwaleta hapa duniani, kisha tukawakimbia.Hatutasamehewa duniani na akhera.

Mwenye njaa hana miiko. Ili kijiruzuku, hawa watoto daima wanachumia jaani.Kwa kudura ya jalia, huenda siku moja watalia kivulini. Asiyekuwa na wake ana mungu.Aghalabu, watoto wanaozurura mitaani hupewa pesa na wafadhili. Wakati mwingine wanaiba. Maisha haya ya kuomba au kuiba wanaona yanaridhisha Zaidi kuliko kumenyeka na kazi ya kibarua kutwa kucha. Kwa bahati mbaya,



## ***KCSE Predictions Marking Schemes - 0707550000 / 0705525657***

watoto hawa wamatumia pesa wanazopata kutoka kwa wafadhili kujichimbia kaburi. Aidha pesa wanazopatiwa watoto hawa wanazitumia kununulia gundi badala ya chakula.

Wafadhili wanashauriwa wawape chakula hawa watoto badala ya pesa taslimu. Kusema kweli, unapompa mtoto wa mitaani pesa, utakuwa unainua biashara ya mwenye kiwanda cha gundi, jambo ambalo litakuwa sawa na kuweka sahihi mkataba wa kifo cha mtoto mwenyewe.

Wataalamu wa afya wanaonya kuwa gundi ikivutwa kwa muda mrefu inaweza kusababisha upofu au kifo. Wataalamu hawa wanazidi kutuarifu kuwa matumizi ya muda mrefu ya gundi huathiri ubongo, figo na maini. Mtumiaji pia anaweza kupoteza uwezo wa kutembea na hata kupooza kabisa.

Sababu wanazotoa hawa watoto ni kwamba, uvutaji gundi, huwaondolea njaa, baridi ya usiku na kuwatuliza mawazo. Ni jambo la kusikitisha kwamba tunaendelea kushuhudia bila kujali hawa watoto ambao ni kiungo cha jamii yetu, wakijiangamiza. Wananchi kwa ujumla hawaha budi kuhamasishwa dhidi ya athari ya matumizi ya gundi. Wafanya biashara wanaowauzia watoto hawa gundi yafaa wakome, la sivyo wachukuliwe hatua. Kutolitua tatizo hili la watoto wa mitaani hivi sasa, kutapeleka kuwako kwa kizazi cha mitaani ambacho kitazaliwa mitaani, kulelewa mitaani, kuoa mitaani na kufia mitaani. Kadiri mataifa yanavyoendelea kujitia hamnazo kuhusiana na swala hili, ndivyo tunavyokubalia jinai itawale, sasa na wakati ujao.

Hawa watoto watakapokua, watageuka kuwa wapigaji watu kabari, majambazi, wezi wa kutumia nguvu ama watatumiwa na mahaini kutimiza uhaini wao. Hawa watoto wenye njaa, watalazimika hatimaye, kuwatoa wenywe shibe tonge mdomoni. Matokeo ya hali hii ni kwamba katika siku zijazo, hawa ndio watu watakaotunyima starehe ya kulala unono. Watatuchafya mitaani, majumbani, vijijini na kutuvizia mabarabarani. Tuna sababu nzuri ya kutiwa hofu na tatizo hili, kwani jinsi kizazi kinavyozidi kupanuka, inaonekana tumelitega bomu ambalo litakuja kutulipukia usoni mwetu.”

### **Maswali**

(a) Taja jambo moja linalochangia kuweko kwa watoto wanaorandaranda mitaani. (alama 1)

.....

.....

.....

.....



**(b) Maisha ya mitaani huathirije watoto?**

**( alama 3)**

.....  
.....  
.....  
.....  
.....  
.....  
.....  
.....  
.....  
.....

**(c) Tatizo la watoto wanaorandaranda mitaani laweza kutatuliwaje?**

**(alama 3)**

.....  
.....  
.....  
.....  
.....  
.....  
.....  
.....  
.....  
.....

**(d) Eleza maana ya:**

**(alama 2)**

**i. Hawa watoto wanachumia jaani**

.....  
.....  
.....  
.....

**ii. Jinsi kizazi cha mitaani kinavyozidi kupanuka, inaonekana tumelitega bomu ambalo litakuja kutulipukia usoni mwetu.**

**(alama 2)**

.....  
.....  
.....  
.....  
.....  
.....



iii. Mwenye njaa hana miiko. (alama 2)

.....  
.....  
.....  
.....  
.....  
.....

(e) Eleza maana ya maneno yafuatayo kama yalivyotumika kwenye taaria: (alama 2)

i. Aidha:

.....  
.....  
.....

ii. Gundi:

.....  
.....  
.....

## 2. UFUPISHO

*Soma taarifa ifuatayo kisha ujibu maswali yanayofuata.*

Kadiri jamii mbalimbali zinavyotagusana, ndivyo lugha zinazozungumzwa na jamii hizi nazo zinavyoingiliana na kuathiriana. Mojawapo ya athari hizi ni ukopaji wa msamiati. Jamii zinazopakana au kutagusana hukopa msamiati kutoka kwa lugha jirani na kuutumia kuelezea dhana mpya zinazolingia katika utamaduni wao kupitia kwa mitagusano ya kijamii.

Lugha ya Kiingereza, kwa mfano, imekopa kutoka lugha nyingine kama vile Kifaransa na Kilatini. Mathalani, istilahi nyingi za kisheria zimekopwa kutoka lugha ya Kifaransa. Aidha, Kiingereza kimekopa kutoka lugha ya Kiswahili. Maneno ya Kiswahili kama vile mwalimu, jiko, mandazi, panga, buibui, ngoma na hata wananchi, sasa yameingia katika kamusi za Kiingereza, kumaanisha kuwa yamekubaliwa kama msamiati rasmi wa lugha ya Kiingereza.

Kiswahili nacho kimeathiriwa na lugha nyingine. Kimekopa msamiati wa Kiingereza na hata Kiarabu. Katika tungo nyingi za kishairi, kwa mfano, Utenzi wa Mwanakupona utapata msamiati wa Kiarabu uliotoholewa. Lugha nyingine ambazo zimeathiri Kiswahili ni pamoja na Kijerumani ambako msamiati



## ***KCSE Predictions Marking Schemes - 0707550000 / 0705525657***

kama vile ‘shule’ ulikopwa na kutoholewa kwa neno *schule*. Msamiati kama vile ‘leso’, ‘karata’ na ‘mvinyo’ yamekopwa kutoka lugha ya Kireno, huku majina ‘balazi’ na ‘bahasha’ yakikopwa kutoka Kitaruki.

Pamoja na ukopaji wa vipengele vya lugha, mtagusano wa lugha una athari nyingine. Lugha zinapokuja pamoja, mazingira ya wingi-lugha huzuka. Baadhi ya watu hujifunza zaidi ya lugha moja. Mtu anayeweza kuzungumza zaidi ya lugha moja anaweza kujieleza kwa urahisi kwa kuchanganya msamiati wa lugha tofauti. Aidha, anaweza kubadilisha msimbo kulingana na matilaha yake. Ikiwa anataka kukubalika na jamii-lugha anayotagusana nayo, atatumia lugha ya jamii hiyo ili kujinasibisha na kujitambulisha nayo. Wazungumzaji hupata visawe vya maneno kuelezea dhana zile zile, hivyo kuboresha mitindo yao ya mawasiliano.

Kadhalika, kutagusana kwa lugha kunaweza kusababisha kubuniwa kwa lugha ngeni ambayo inarahisisha mawasiliano. Wakati mwingine, watu wanaozungumza lugha tofauti wanapokutana, hubuni mfumo *sahili wa lugha* ili kufanikisha mawasiliano. *Pijini* ni mfano wa lugha iliyobuniwa kwa njia hii. *Pijini* huchota msamiati kutoka lugha zilizotagusana. *Sheng* ni mfano mwingine wa lugha ambayo ilibuniwa kutokana na kutagusana kwa lugha ya Kiswahili, lugha za kiasili na Kiingereza.

Japokuwa kuna faida nyingi za wingi-lugha, hasara pia zipo. Mazingira ya wingi-lugha huwapa wazungumzaji fursa ya kuchagua lugha wanayotaka kuwasiliana kwayo. Katika hali hii, lugha yenye ushawishi mkubwa kijamii, kiuchumi na kisiasa ndiyo inayopendelewa zaidi. Wingi-lugha unaweza kusababisha kukweza kwa lugha moja na kudunishwa kwa lugha nyingine. Mathalani, kuwepo kwa lugha nyingi nchini kulizua haja ya kukweza kwa lugha ya Kiswahili huku zingine za kiasili zikipuuzwa.

Lugha hukua kwa kutumiwa. Lugha isipozungumzwa kwa muda mrefu, watu hupoteza umilisi ambao huifanya kuwa vigumu kuirithisha kwa vizazi. Lugha inaweza pia kukosa wazungumzaji ikiwa wale wanaoizungumza ni wachache, au ikaathiriwa na mtagusano na lugha nyingine iliyo na wazungumzaji wengi. Katika hali kama hii, lugha hiyo hukabiliwa na tisho la kudidimia au hata kufa. Ikiwa jamii itakosa kudhibiti sera za matumizi ya lugha yake, baadhi ya lugha zitafifia au zitakufa na kusahaulika kabisa.

1. Bila kupoteza maana, fupisha aya za kwanza tatu. (Maneno 50-60)(Alama 10, 1 ya mtiririko)





**Matayarisho**

.....

.....

.....

.....

.....

.....

.....

.....

.....

**Jibu**

.....

.....

.....

.....

.....

.....

.....

.....

.....

.....

.....



2. Kwa mujibu wa taarifa hii, mtagusano wa lugha una athari gani?maneno 20-30  
(Alama 5, 1 ya mtiririko)

**Matayarisho**

.....  
.....  
.....  
.....  
.....  
.....  
.....

**Jibu**

.....  
.....  
.....  
.....  
.....  
.....  
.....  
.....

**SEHEMU YA C: MATUMIZI YA LUGHA**

**(ALAMA 40)**

- (a) Taja sifa tatu za kuainisha irabu (alama2)

.....  
.....  
.....  
.....

- (b) Ainisha viambishi katika neno lifuatalo: (alama2)

Alifiwa

.....  
.....



.....  
.....  
....

- (c) Bainisha shamirisho katika sentensi ifuatayo: (alama 2)  
Zainabu aliandikiwa barua na Zubeda

.....  
.....  
.....  
.....  
.....

- (d) Onyesha miundo mitatu ya kundi nomino (alama 3)

.....  
.....  
.....  
.....

- (e) Andika maana mbili tofauti ya sentensi ifuatayo (alama 2)  
Walipiganishwa na kakake

.....  
.....  
.....  
.....  
.....  
.....  
.....

- (f) Tunga sentensi tatu tofauti kuonyesha matumizi matatus ya ngeli ya mahali (alama 3)

.....  
.....  
.....  
.....  
.....

- (g) Ainisha vielezi namna katika sentensi ifuatayo; [alama 2]  
Mlevi alianguka mchangani tifu kwa kutembea ovyo.

.....  
.....  
.....



.....  
.....  
.....

**(h) Nyambua vitenzi vifuatavyo katika kauli ulizopewa (alama 2)**

a. LA [TENDESHA]

.....  
.....  
.....

b.soma[tendeana].....

.....  
.....  
.....  
.....  
.....

**(i) Changanua sentensi ifuatayo kwa njia ya visanduku (alama 4)**

Yule mzee ajengaye barabara ametuzwa.

.....  
.....  
.....  
.....  
.....  
.....  
.....  
.....  
.....  
.....  
.....  
.....  
.....  
.....

**(j) Andika katika usemi wa taarifa. (alama 4)**

“Karibu Bakari,tafadhali kaa,” Juma akasema. “Asante je,habari za nyumbani?”

.....  
.....  
.....



.....  
.....  
.....

**(k)** Onyesha kishazi huru na kishazi tegemezi katika sentensi ifutayo. **(alama 1)**

Ukuta uliobomolewa ulisababisha hasara kubwa.

.....  
.....  
.....

**(l)** Unda nomino mbili kutokana na neno **dhuru** **(alama 2)**

.....  
.....  
.....

**(m)** Andika kinyume cha:  
(alama1)

Walizama walipokuwa wakikusanya mchanga.

.....  
.....  
.....  
.....  
.....  
.....

**(n)** Tunga sentensi moja kutofautisha baina ya **bure** na **pure** **(alama 2)**

.....  
.....  
.....  
.....  
.....  
.....

**(o)** Bainisha matumizi ya **ku** katika sentensi hii **(alama 3)**  
Mkurugenzi hakukusaidia ulipoenda kula Mombasa anakofanya kazi.

.....  
.....  
.....  
.....



.....  
.....

(p) Tunga sentensi katika wakati uliopita hali timilifu (alama 2)

.....  
.....  
.....

(q) Bumba ni kwa nyuki.....ni kwa samaki na.....ni kwa siafu.  
(alama 2)

(r) Eleza maana ya ngeli (alama 1)

.....  
.....  
.....

**SEHEMU YA D: ISIMU JAMII** (alama 10)

Kwa kutumia sifa **tano**, linganua sajili ya mahakamani na sajili ya sokoni (alama 10)

.....  
.....  
.....  
.....  
.....  
.....  
.....  
.....  
.....  
.....  
.....  
.....  
.....  
.....  
.....  
.....  
.....  
.....  
.....  
.....



*KCSE Predictions Marking Schemes - 0707550000 / 0705525657*

.....

.....

.....

.....

.....

.....

.....

.....

.....

.....

.....

.....

.....

.....

.....

.....

.....



# KCSE 2021 PREDICTION

NAME..... INDEX NO.....

SCHOOL..... SIGN.....

DATE.....

102/3

## KISWAHILI

Paper 3

Karatasi ya Tatu

MUDA MASAA 2 ½

### MAAGIZO

- Andika jina na nambari yako kwenye nafasi ulizoachiwa hapo juu.
- Tia sahihi yako kisha uandike tarehe ya mtihani.
- Jibu maswali yote.
- Andika majibu yako katika nafasi ulizoachiwa katika kijitabu hiki cha maswali.
- Majibu yako yaandikwe kwa lugha ya kiswahili





**SWALI LA LAZIMA.**

**1. Soma kifungu kifuatacho kisha ujibu maswali.**

Hapo zamani za kale paliishi sungura na ndovu. Wanyama hawa waliishi baharini. Maulana alikuwa amewatunukia mapenzi si haba. Makazi yao yalikuwa yamepambwa yakapambika. Walitegemea matunda mbalimbali yaliyokuwa baharini kama mapera, matomoko, matikitimaji na kadhalika.

Siku moja usiku wa manane, maji yakaanza kupwa. Ndovu aliathirika zaidi. Alijaribu kuinama majini lakini hakuweza. Alimwita sungura amsaidie lakini sungura alikuwa ametoweka.

Ndovu aliamua kwenda kumtafuta sungura. Alimtafuta hadi msituni lakini hakumpata. Alihofia kurudi baharini na hadi wa leo yumo msituni.

***Maswali***

- (a) Tambua utanzu na kijipera chake. (al.2)  
(b) Taja fomyula zingine mbili za kutanguliza kifungu hiki. (al.2)  
(c) Eleza umuhimu wa kijipera hiki. (al.5)  
(d) Eleza sifa za kifungu hiki. (al.5)  
(e) Eleza umuhimu wa fomyula:  
(i) Kutanguliza (al.3)  
(ii) Kuhitimisha (al.3)

**TAMTHILIA ; KIGOGO NA TIMOTHY AREGE**

2. Tulipoanza safari hii matangazo yalikuwa bayana, dhahiri shahiri babu!  
(a) Eleza muktadha wa dondo hili. (al.4)  
(b) Tambua mbinu za uandishi zilizotumika katika kifungu hiki. (al.4)  
(c) Eleza matatizo yanayoikumba safari inayorejelewa. (al.12)
3. Eleza nafasi ya mwanamke katika jamii ya kigogo. (al.20)

**RIWAYA YA CHOZI LA HERI NA ASHUMTA K. MATEI**

4. Matatizo mengi yanayowakumba wahusika wengi katika riwaya hii ni mwiba wa kujidunga. Jadili (al.20)
5. Kwa kurejelea riwaya hii, fafania mbinu zifuatazo. (al.20)
- (i) Kinaya  
(ii) Mbinu rejeshi  
(iii) Sadfa  
(iv) Jazanda



**HADITHI FUPI : TUMBO LISILISHIBA.**

6. Kwa kurejelea hadithi ya *Mapenzi ya kifaurongo na shogake dada ana ndevu* fafanua changamoto zinazowakumba vijana. **(al.20)**
7. ***Mame Bakari***  
“Una nini ? Umeshtuka mwanangu ! Unaogopa? Unaogopa nini?”
- (a) Weka dondoo hili katika muktadha wake. **(al.4)**
- (b) Tambua mbinu **mbili** za lugha zilizotumika katika dondoo. **(al.2)**
- (c) Eleza sifa za mrejelewa. **(al.6)**
- (d) Eleza umuhimu wa msemaji. **(al.4)**
- (e) Tambua maudhui yanayojitokeza katika kifungu hiki. **(al.1)**
- (f) Fafanua maudhui katika swali la (e) kwa kurejelea hadithi nzima. **(al.3)**

**USHAIRI.**

**Soma shairi hili kisha ujibu maswali.**

Sinusubuwe akili, nakusihi e mwandani

Afiya yangu dhahili, mno nataka amani

Nawe umenikabili, nenende sipitalini Sisi  
tokea azali, twende zetu mizimuni Nifwateni  
sipitali, na dawa ziko nyumbani?

Mababu hawakujali, wajihisipo tabani

Tuna dawa za asili, hupati sipitalini

Kwa nguvu ya kirijali, mkuyati uamini Kaafuri  
pia kali, dawa ya ndwele fulani Nifwateni sipitali, na  
dawa ziko nyumbani.

Mtu akiwa halali, tumbo lina walakini

Dawa yake ni subili, au zogo huauni

Zabadi pia sahali, kwa maradhi yalo ndani Au  
kwenda wasaili, wenyewe walo pangani

Nifwateni sipitali, na dawa ziko nyumbani



Mtu kwenda sipitali, nikutojuwa yakini.

Daktari kona mwili, tanena kansa tumboni

Visu vitiwe makali, tayari kwa pirisheni Ukatwe  
kama figili, tumbo nyangwe na maini

Nifwateni sipitali, na dawa ziko nyumbani

Japo maradhi dhahili, kuteguliwa tegoni,

Yakifika sipitali, huwa hayana kifani

Waambiwa damu, kalili ndugu msaidieni

Watu wakitamali, kumbe ndio buriani

Nifwateni sipitali, na dawa ziko nyumbani

Mizimu wakupa kweli, wakueleze undani

Maradhiyo ni ajali, yataka vitu dhamani

Ulete kuku wawili, wamajano na wa kijani  
Matunda pia asali, vitu vyae chanoni Nifwateni  
sipitali, na dawa zi mlangoni?

**Maswali.**

1. Lipe shairi hii anwani mwafaka. (al.1)
2. Toa sababu zinazofanya mshairi kutaka kwenda hospitali. (al.3)
3. Andika ubeti wanne kwa lugha ya nathari/ tutumbi. (al.4)
4. Taja bahari **mbili** zilizotumika katika shairi hili. (al.2)
5. Tambua nafsini katika shairi hili. (al.1)
6. Tambua toni ya shairi hili. (al.1)
7. Eleza muundo wa shairi hili. (al.4)
8. Fafanua uhuru wa mshairi unavyojitokeza katika shairi hili. (al.2)
9. Andika maana ya maneno yafuatayo kama yalivyotumika katika shairi hili. (al.2)
  - (i) dhalili
  - (ii) azali



# KCSE 2021 PREDICTION

NAME..... INDEX NO.....

SCHOOL..... SIGN.....

DATE.....

443/1

## AGRICULTURE

Paper 1

2 HOURS

### Instructions to candidates

- (a) Write your **name**, **index number** and the **name** of your school in the spaces provided above.
- (b) **Sign** and **write the date** of examination in the spaces provided above.
- (c) This paper consists of **3 sections A, B and C**. Answer **all questions in section A and B** and **any two** from section C. All answers must be written in the answer booklet provided.
- (d) All Answers must be written in **English**
- (e) **Candidates should check to ascertain that all pages are printed as indicated and that no questions are missing.**

### FOR EXAMINER'S USE ONLY

Section	Question	Maximum score	Candidates score
A	1-15	30	
B	16-20	20	
C	21-23	40	
Total score		90	



**SECTION A ( 30 MKS)**

**ANSWER ALL QUESTIONS IN THE SPACES PROVIDED**

1. Give 4 factors that characterize large scale farming (2mks)

.....

.....

.....

.....

.....

2. State 4 reasons for treating water on farm (2mks)

.....

.....

.....

.....

.....

3. Give 4 examples of working capital in the production of maize (2mks)

.....

.....

.....

.....

.....

4. Explain the meaning of the following terms (1mk)  
i) Nitrogen –fixation in the soil

.....

.....

.....



ii) phosphorus-fixation in loss of soil fertility **(1mk)**

.....  
.....  
.....

5. Give the element whose deficiency in plants is plants is characterized by the following

(a) Interveinal chlorosis of the leaves ..... **(½ mark)**

(b) Blossom end rot in tomatoes ..... **(½ mark)**

(c) Scorched edges of a leaf ..... **(½ mark)**

6. State two activities carried out during hardening cabbage plants in the nursery **(2mks)**

(i) .....

(ii) .....

7. Name three methods of controlling blossom endrot in tomatoes **(1 ½ mk)**

(i) .....

(ii) .....

(iii) .....

8. Outline four conditions that may lead to agricultural land fragmentation and subdivision **(2mks)**

.....  
.....  
.....  
.....  
.....



**9.** State four factors that influence solifluction **(2 marks)**

.....

.....

.....

.....

.....

**10.** Give four reasons for keeping health records **(2 marks)**

.....

.....

.....

.....

.....

**11.** Name four processes involved in chemical weathering **(2mks)**

.....

.....

.....

.....

.....

**12.** Outline four reasons why it is undesirable to carry out minimum tillage before planting **(2mks)**

.....

.....

.....

.....

.....



**13.** State four advantages of practicing crop rotation  
(2mks)

.....  
.....  
.....  
.....  
.....

**14.** State four factors that determine the stage at which a crop is harvested (2mks)

.....  
.....  
.....  
.....  
.....

**15.** Below is a list of weeds found in the farm. Use them to answer the questions below.  
Wild oat, Wondering Jew, pigweed, Mexican Marigold, Sodom Apple, Couch Grass  
and Thorn Apple.

i) Name two narrow leaved weeds. (1 mark)

.....

ii) Give two weeds that are poisonous. (1 mark)

.....

iii) Identify two annual weeds from the above list (1 mark)

.....  
.....





**SECTION B (20MRKS)**

**Answer all the questions in their section in the spaces provided.**

**16.** The diagrams below illustrate both field and storage pests

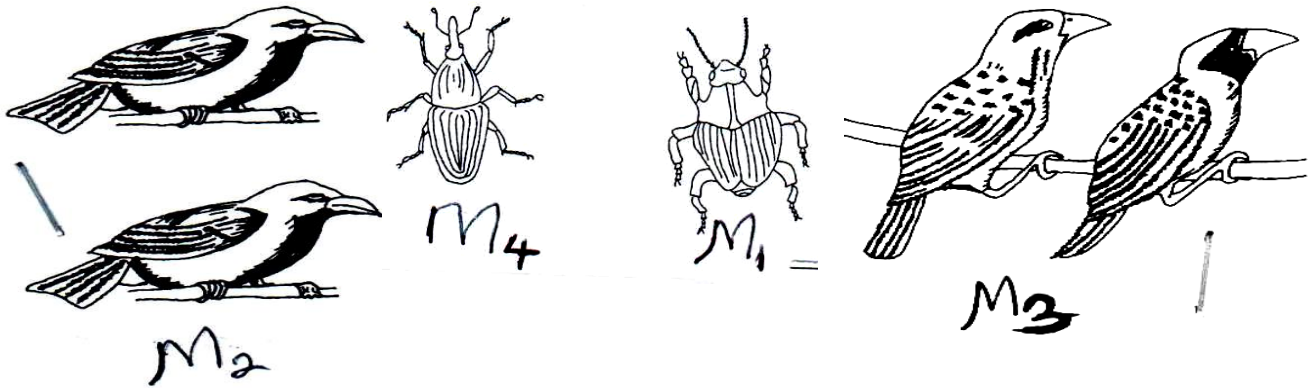

a) Identify the pests in the illustration. (1mark)

M<sub>1</sub>:.....

M<sub>2</sub>:.....

b) State **two** ways by which pest labelled M<sub>2</sub> causes loss in cereal crops.

(2marks)

.....  
.....  
.....

c) State **two** methods which are used to control the pest labeled M<sub>2</sub>. (2marks)

.....  
.....  
.....

17. Study the diagram of cut off drain below and answer the questions that follow.

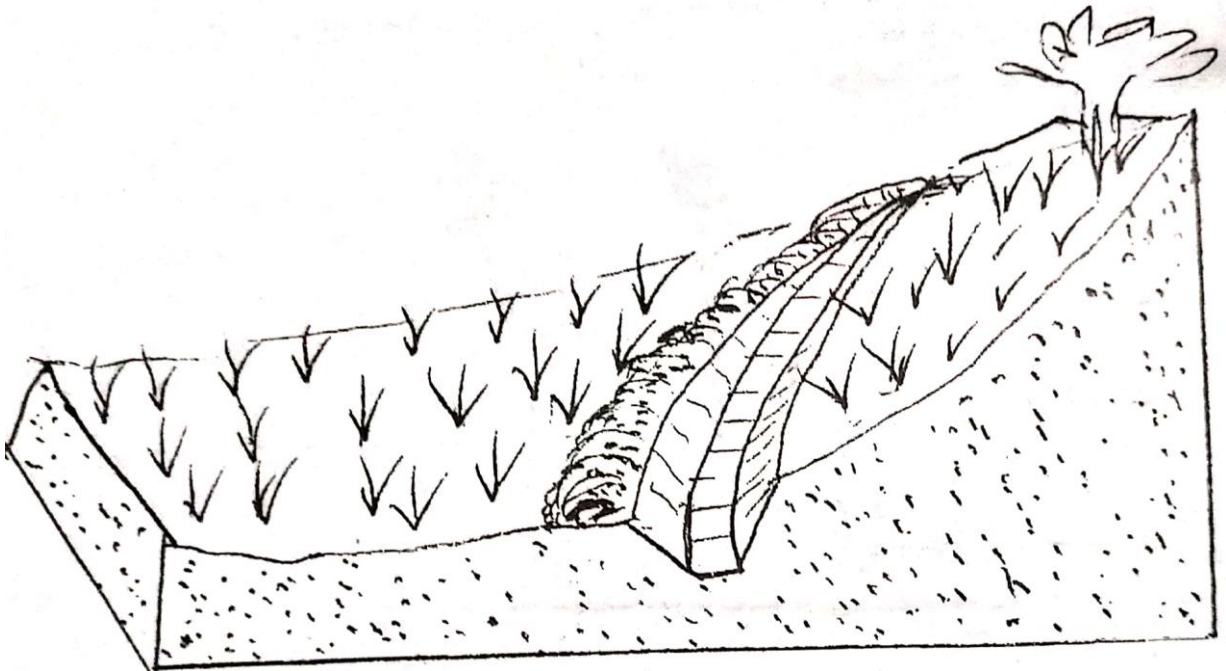

a) Outline the procedure of constructing a cutoff

**4mks**

.....

.....

.....

.....

b) State two ways through which the methods above helps in soil and water conservation

**(2mrks)**

.....

.....

.....

.....

- 18)** The diagrams below labeled H and J are illustrated of coffee plants establishing using two different pruning systems. Examine them closely and answer the questions that follow



- a)** Name the pruning systems illustrated by diagrams H and J **(1 mark)**

**H**.....

**J**.....

- b)** Give one advantages of pruning system illustrated by diagram H. Over that one illustrated by diagram J **(1 mark)**

.....  
.....

- 19 (a)** A farmer was advised to apply 40kg/ha.P<sub>2</sub>O<sub>5</sub>. Calculate the amount of DSP the farmer will require for 2 ha of land. Show your working(DSP has 20%P<sub>2</sub>O<sub>5</sub>) **(3mks)**

20. The table shows output of maize at various quantities D.A.P. application per hectare.

<b>FIXED INPUT(LAND)</b>	<b>VARIABLE INPUT D.A.P IN 30 KG BAG</b>	<b>TOTAL PRODUCT MAIZE IN 90 KG BAG</b>	<b>AVERAGE PRODUCT (AP)</b>	<b>MARGINAL PRODUCT(MP)</b>
1	0	2		
1	1	5		
1	2	14		
1	3	21		
1	4	26		

Fill in the table above to show average product (AP) and marginal product (MP) (4mks)

**SECTION C (40MARKS)**

**Answer any TWO questions from this section in the spaces provided after question 23**

21. (a) A farmer wishes to change her enterprise from vegetable production to dairy cattle rearing. The costs she incurs in growing of vegetables is as follows:
- Weeding Sh. 200, Harvesting Sh. 300, Fertilizers Sh. 500 and Seeds Sh. 400. When she changes her enterprises to dairy cattle rearing, she incurs the following cost:
  - Cost of buying cattle Sh. 5000 ,Disease control, Sh. 200 ,Salary of milk person Sh. 2000 and Fencing Sh. 500 .The revenue she got when growing vegetable is 10,000.
- In dairy production, the revenue she gets from milk sales is Shs. 15,000 and manure sales shs. 1,000.
- Draw up the partial budget and indicate if the change is worthwhile. (Show your working) (10marks)
- (b) Explain five benefits of agro-forestry in agriculture (5mks)
- (c) Outline any five problems facing agriculture in Kenya (5mks)



22. (a) Explain five roles played by a good manager (5mks)  
(b) Explain five benefits of land consolidation (10mks)  
(c) Outline five effects of late defoliation in forage crops (5mks)
23. (a) Explain five factors that may influence the spacing used during planting of crops (10mks)  
(b) Outline five precautions taken when harvesting tea (5mks)  
(c) Outline five characteristics of plants suitable for making green manure (5mks)



# KCSE 2021 PREDICTION

NAME..... INDEX NO.....

SCHOOL..... SIGN.....

DATE.....

443/2

## AGRICULTURE

Paper 2

2 HOURS

### Instructions to candidates

- (a) Write your **name**, **index number** and the **name** of your school in the spaces provided above.
- (b) **Sign** and **write the date** of examination in the spaces provided above.
- (c) This paper consists of 3 sections A, B and C. Answer **all questions in section A and B** and **any two** from section C. All answers must be written in the answer booklet provided.
- (d) All Answers must be written in **English**
- (e) Candidates should check to ascertain that all pages are printed as indicated and that no questions are missing.

### FOR EXAMINER'S USE ONLY

Section	Question	Maximum score	Candidates score
A	1-16	30	
B	17-20	20	
C	21-23	40	
Total score		90	



**SECTION A (30 MARKS)**

**Answer all the questions in this section in the spaces provided.**

1. State four light breeds in poultry (2 marks)

.....  
.....  
.....  
.....  
.....  
.....

2. Give two effects of lice infestation in sheep production (1 mark)

.....  
.....  
.....  
.....

3. State four advantages of contemporary comparison in selection of livestock. (2 marks)

.....  
.....  
.....  
.....  
.....  
.....

4. State two reasons for docking in sheep management (1 mark)

.....  
.....  
.....  
.....  
.....



**5. State two functions of differential in a tractor transmission system. (1 mark)**

.....  
.....  
.....  
.....

**6. Give four effects of protein deficiency in livestock production. (2 marks)**

.....  
.....  
.....  
.....  
.....  
.....  
.....

**7. State four predisposing factors of pneumonia in livestock production. (2 marks)**

.....  
.....  
.....  
.....  
.....  
.....

**8. Give four factors influencing milk let down in dairy cattle production. (2 marks)**

.....  
.....  
.....  
.....  
.....





**9.** Name four instances where animal power is advantageous over other form of powers.

**(2 marks)**

.....  
.....  
.....  
.....  
.....  
.....

**10.** State four reasons for handling dairy cattle in livestock production.

**(2 marks)**

.....  
.....  
.....  
.....  
.....  
.....

**11.** Give factors considered in choice of rearing systems in poultry production.

**(2 marks)**

.....  
.....  
.....  
.....  
.....  
.....

**12.** State four factors that affect the choice of feedstuff in livestock.

**(2marks)**

.....  
.....  
.....  
.....  
.....



**13.** Give four practices carried out on fish before preservation. **(2 mark)**

.....  
.....  
.....  
.....  
.....  
.....

**14.** State four disadvantages of live fence in livestock production. **(2 marks)**

.....  
.....  
.....  
.....  
.....

**15.a)** Give four prophylactic measures used in controlling diseases in livestock. **(2 marks)**

.....  
.....  
.....  
.....  
.....

**b)** State **four** practices that ensure maximum harvest of fish. **(2mks)**

.....  
.....  
.....  
.....  
.....



16.State two functions of caecum in poultry production. (1 mark)

.....  
.....  
.....  
.....

**SECTION B (20 MARKS)**

**Answer all the questions in this section in the spaces provided.**

17.Below is an illustration of a farm implement. Study it carefully and answer the questions that follow.

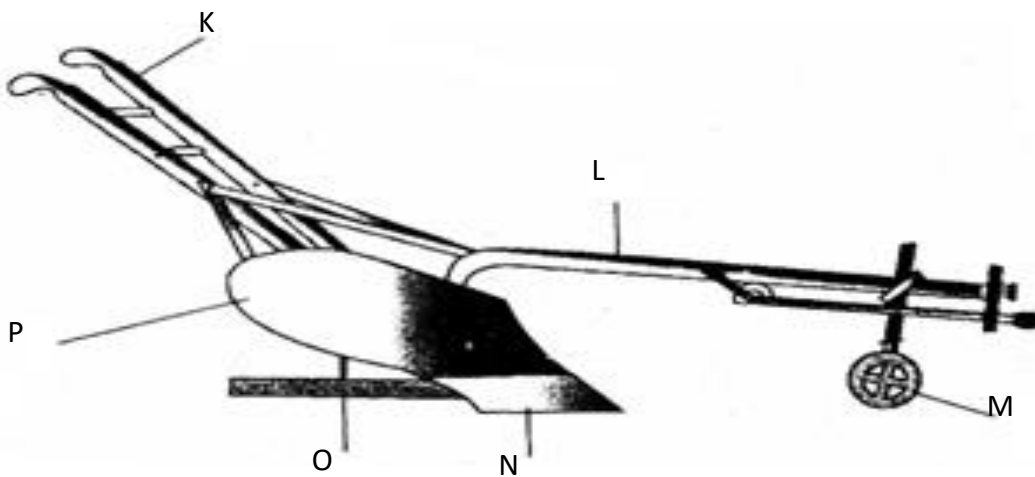

a. Identify the farm implement. (1mk)

.....  
.....

b. Name the parts labeled L, M, O and P. (2mks)

L.....

M.....

O.....

P.....

c. Give one function of the parts **M**, **N** and **P**. (3mks)

**M**.....

**N**.....

**P**.....

**18.** Below are illustrations of farm tools and equipment.

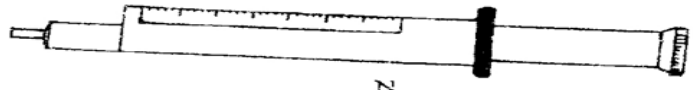
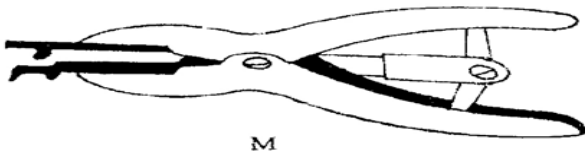
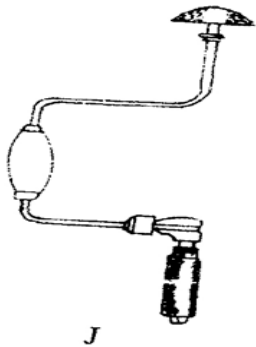

a) Identify the tool labelled J and K

**J** (1 mark)  
.....

**K** (1 mark)  
.....

(b) State one use of tool M and N. (2mks)

**M**.....  
.....  
.....

N.....  
.....  
.....

(c) Explain one maintenance practice carried on tool J. (1mk)

.....  
.....  
.....

19. The diagram below illustrates a calf rearing practice.



a) Identify the practice illustrated above. (1mk)

.....  
.....

b) i) Describe the procedure followed in the feeding practice named in (a) above. (3mks)

.....  
.....  
.....  
.....  
.....

ii) Give *two* precautions taken while using the rearing practice stated in (a) above. (1mk)

.....  
.....

.....  
.....  
**20.** The diagram below is an illustration of an egg. Study it carefully and answer the questions that follow.

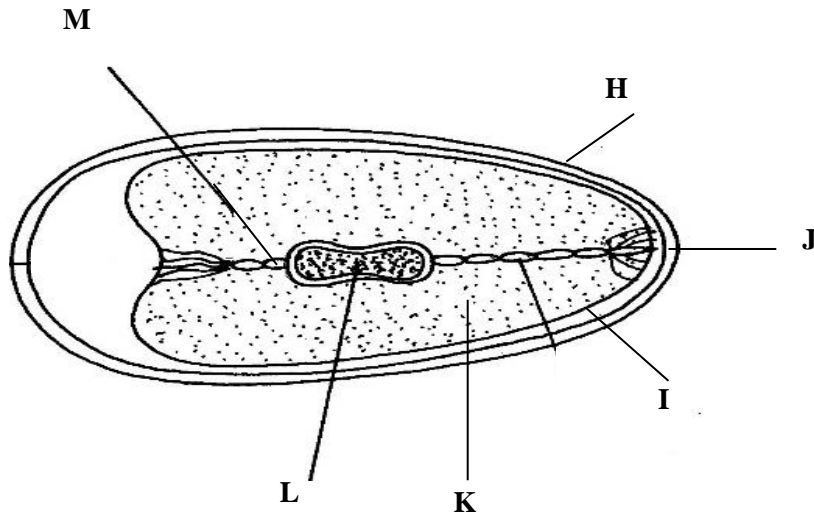

a) Name the parts labelled I, J, K and M. **(2 Marks)**

.....  
.....  
.....  
.....  
.....

b) Give two qualities of the part labelled H that would be considered when selecting eggs for incubation. **(1 Mark)**

.....  
.....  
.....  
.....

c) What is the function of the part labelled L **(1 Mark)**

.....  
.....  
.....

**SECTION C (40 Marks)**

**Answer any two questions from this section.**

- 21.a)** State five reasons for feeding livestock (5 marks)
- b) Describe the factors a farmer should consider when selecting a gilt for breeding.  
(8 marks)
- c) Outline seven management practices that a farmer should carry out to maintain good health in a herd of cattle. (7 marks)
- 22. a)** Outline routine maintenance practices that should be carried out in deep litter system.  
(5 marks)
- b) State eight practices that would ensure clean milk production. (8 marks)
- c) Compare the use of an ox-drawn mouldboard plough with that of a tractor drawn plough(7 mk)
- 23.a)** Give FIVE general characteristics of dairy cattle breeds (5marks)
- (b) Outline the procedure one would follow when castrating a male piglet. (5mks)
- c) Outline five causes of stress in poultry. (5 marks)
- d) Describe the life cycle of two host tick (5 marks)

.....

.....

.....

.....

.....

.....

.....

.....

.....

.....

.....

.....

.....

.....

.....

.....







# KCSE 2021 PREDICTION

NAME..... INDEX NO.....

SCHOOL..... SIGN.....

DATE.....

565/1

## BUSINESS STUDIES

Paper 1

2 HOURS

### Instructions to candidates

- (a) Write your **name**, **index number** and the **name** of your school in the spaces provided above.
- (b) **Sign** and write the **date** of examination in the spaces provided above.
- (c) All Answers must be written in **English**
- (d) Candidates should check to ascertain that all pages are printed as indicated and that no questions are missing.



**ANSWER ALL THE QUESTIONS IN THE SPACES PROVIDED**

1. Identify the level of production for each of the following activities. (4mks)

	<b>Activity</b>	<b>Level of production</b>
(a)	Painting a house	
(b)	Constructing a road	
(c)	Insuring a car	
(d)	Dress making	

2. Outline **four** reasons why road transport is still the most referred mode of transport from Nairobi to Mombasa despite the introduction of Standard Gauge Railway (4 marks)

.....

.....

.....

.....

.....

.....

.....

3. Determine the initial capital of ABC business whose details are as follows:

Capital on 31 dec 2001 was shs 120,000

Net loss during the year was shs 70,000

Drawings were shs 20,000 on a quarterly basis

Owner’s investment was shs 20,000



**4.** State any **four** functions of the central bank to the commercial banks

.....

.....

.....

.....

.....

.....

.....

**5.** The following transactions took place in the business of Onyuma during the month of June 2016.

June 03.2016- office furniture worth 80,000 was sold at 90,000 on credit to Butere restaurant.

June 29.2016- Motor vehicle worth 1000,000 was bought from CMC motors paying 400,000 cash and the rest to be paid later.



**6.** Outline **four** circumstances under which an insurance company may re-insure **(4marks)**

.....

.....

.....

.....

.....

.....

**7.** State **four** auxiliary services that may attract business enterprises in an area **(4 marks)**

.....

.....

.....

.....

.....

.....

**8.** The table below shows the general change of price for a certain commodity over a period of five years.

	<b>Year</b>	<b>Price (Ksh)</b>	<b>C P I</b>
(a)	2008	92.00	-
(b)	2009	100.80	-109.56%
(c)	2010	104.50	-113.59%
(d)	2011	105.30	-114.46%
(e)	2012	101.50	-110.33%

**Required:**

Using year 2008 as the base year, determine the consumer price index for year 2009, 2010, 2011 and 2012 **(4 marks)**



**9.** State any **four** challenges of a population made up of a large proportion of young people

.....  
.....  
.....  
.....  
.....  
.....

**10.** Highlight **four** forms of written communication that the minister of education could use to pass on information **(4 marks)**

.....  
.....  
.....  
.....  
.....  
.....

**11.** Mr. Musee had the following balances in his business on 1st Jan. 2008

Motor van	65,000
Cash at bank	52,400
Machine	6,800
Creditors	15,900
Debtors	30,000
Loan	3,000
Stock	22,600

The following transactions took place in the month of Jan. 2008

Sold stock valued shs. 5000 for shs. 7,500 cash

Exchange the motor van with a tractor valued at shs. 65,000

The debtor paid by cash shs. 10,000

**Prepare:** Mr. Musee’s balance sheet as at 31st Jan. 2008



12. Identify any **four** characteristics of economic resources (4 marks)

.....  
.....  
.....  
.....  
.....  
.....

13 State **four** features that make chain stores very unique (4 marks)

.....  
.....  
.....  
.....  
.....  
.....

14. Kenyans are more appealed by loans offered by SACCOs rather than those offered by commercial banks. Outline **four** reasons why this is so (4marks)

.....  
.....  
.....  
.....  
.....  
.....



15. Outline **four** challenges that a distributor of fresh milk is likely to face in his operations.

(4MARKS)

.....  
.....  
.....  
.....  
.....  
.....

16. Outline **four** reasons why billboards have become very common medium of advertising in major urban centres (4 marks)

.....  
.....  
.....  
.....  
.....  
.....

17. State **five** ways in which the government finances its expenditure (4mks)

.....  
.....  
.....  
.....  
.....  
.....

18. In the recent past there has been development of **malls** in Nairobi. Highlight **four** disadvantages of such **malls**. (4 marks)

.....  
.....



.....  
.....  
.....  
.....

19.. Indicate the source document for each of the following books of original entry.

**(4 MARKS)**

<u><b>BOOKS OF ORIGINAL ENTRY</b></u>	<u><b>SOURCE DOCUMENT.</b></u>
---------------------------------------	--------------------------------

- |                            |  |
|----------------------------|--|
| a) Sales return daybook    |  |
| b) Cash book               |  |
| c) Purchases journal       |  |
| d) Purchase return journal |  |

20. outline **four** consequences of poor arrangement of goods in a warehouse **4mks**

.....  
.....  
.....  
.....  
.....  
.....  
.....

21. Highlight **four** causes of a shift of demand curve to the left **(4 marks)**

.....  
.....  
.....  
.....  
.....





22. . State **four** benefits that a business in a politically stable country is likely to enjoy  
(4marks)

.....  
.....  
.....  
.....  
.....  
.....

23. The information given below was extracted from the gbooks of amina traders on 31st december 2006

<b>Purchases</b>	<b>260000</b>
<b>Opening stock</b>	<b>75000</b>
<b>Carriage on purchases</b>	<b>12500</b>
<b>Closing stock</b>	<b>27500</b>
<b>Mark-up</b>	<b>25%</b>

Using the information above, prepare Amina traders trading account





.....

.....

.....

.....

.....

.....

.....

.....

.....

25. Highlight **four** ways in which Kenya Association of Manufacturers (KAM) ensures that their members do not exploit consumers. **(4mks)**

.....

.....

.....

.....

.....

.....

.....



# KCSE 2021 PREDICTION

NAME..... INDEX NO.....

SCHOOL..... SIGN.....

DATE.....

565/2

## BUSINESS STUDIES

Paper 2

2 ½ HOURS

### Instructions to candidates

- (a) Write your *name*, *index number* and the *name* of your school in the spaces provided above.
- (b) *Sign* and write the *date* of examination in the spaces provided above.
- (c) Choose *ANY five* questions
- (d) All the questions carry *equal marks*
- (e) Answer the questions in the answer sheets provided
- (f) All Answers must be written in *English*
- (g) Candidates should check to ascertain that all pages are printed as indicated and that no questions are missing.



1. (a). Explain FIVE principles that govern the spending of revenue collected by the government **(10 marks)**  
(b) The table below represent supply schedule of bread to Kiriaini town.

Year	Quantity of bread
2015	10,000
2016	9,000
2017	7,800
2018	5,000

Assuming the price remains constant, explain five possible reasons for the trend in the supply of bread. **(10mks)**

2. (a) Explain **five** factors to consider when evaluating a business opportunity. **(10mks)**

b) As at 1st August 2012 the cash book of Ongeti showed the following balances:

**Cash 10,000, Bank 4,300(Cr)**

**During the month, the following transactions took place:**

**August 3: Tumbo a debtor settled his account of Shs. 8,000 by cheque of Shs. 2,500.**

**August 6: Paid rent by cash Shs. 4,000**

**10: Deposited Shs. 3,000 into the business bank account from the cash till.**

**15: Settled Nyamu's account in the bank of Shs. 10,000 and be allowed a discount of 1%**

**21: Cash sales sh. 6,000.**

**24: Otieno, a debtor, settled his account by a cheque of Shs. 4,000 having been allowed a discount of 20%**

**26: Purchased furniture Shs. 2,600 paying by cheque.**

**28: Received Shs. 1,800 cash from Nduta.**

**30. Banked the available cash except Shs. 800.**

Prepare a dully balanced three column cashbook

**10mks**

3. (a) explain five benefits enjoyed by a a trader who buys goods on credit rather than by cash **(10 marks)**

(b) Explain any five factors that may influence a decrease in the level of national income **10mks**

4. (a) Explain **five** contributions of commercial banks to the Kenyan economy **(10mks)**

( b) Explain five ways in which the efficiency of a warehouse can be enhanced **10mks**

5. (a) Explain **five** ways in which the government may regulate business activities **( 10mks)**



(b) The following trial balance was extracted from the books of Kaiyaba traders on 31<sup>st</sup> December 2001

**Kaiyaba Traders**  
**Trial Balance**  
**As at 31<sup>st</sup> December 2001**

	<b>Dr</b>	<b>Cr</b>
	<b>shs</b>	<b>shs</b>
Gross profit		380,000
Closing stock	274,000	
Capital		259,000
Drawings	83,000	
Creditors		93,000
Premises	103,000	
Debtors	123,000	
Cash at bank	33,000	64,000
Bank loan (1 year)		50,000
General expenses	54,000	
Commission received		20,000
Wages and Salaries	132,000	
	<b><u>802,000</u></b>	<b><u>802,000</u></b>

Prepare: a) Profit and Loss account for the year ended 31<sup>st</sup> December, 2001 (5 marks)

b) Balance Sheet as at 31<sup>st</sup> December, 2001 (5 marks)

6. (a) Explain FIVE features that differentiate a public limited company from a partnership form of business (10 marks)

6. b) The following information relates to Somo Ber Traders for the year 2012.

Capital invested	Kshs 1,000,000
Current ratio	3:2
Rate of Stock Turn over	6 times
Turn over	Kshs 540,000
Expenses	Shs 80,000
Total current Assets	Sh 720,000
Total Fixed Assets	Shs 960,000
Margin	40%

From the above information determine:

(i) Working Capital (2 mks)

(ii) Gross profit. (2mks)



***KCSE Predictions Marking Schemes - 0707550000 / 0705525657***

- |  |        |
|--|--------|
| <b>(iii)</b> Cost of sales.                | (1mk)  |
| <b>(iv)</b> Net profit.                    | (1mk)  |
| <b>(v)</b> Average stock                   | (2mk). |
| <b>(vii)</b> Rate of return on capital.    | (1mk)  |
| <b>(viii)</b> Total long term liabilities. | (1mk)  |



# KCSE 2021 PREDICTION

NAME..... INDEX NO.....

SCHOOL..... SIGN.....

DATE.....

451/1

## COMPUTER STUDIES

Paper 1

2 ½ HOURS

### Instructions to candidates

- (a) Write your **name**, **index number** and the **name** of your school in the spaces provided above.
- (b) Sign and write the **date** of examination in the spaces provided above.
- (c) Answer question **16** and any other **3** in section **B**.
- (d) All Answers must be written in **English**
- (e) Candidates should check to ascertain that all pages are printed as indicated and that no questions are missing.

### FOR EXAMINER'S USE ONLY

Section	Question	Maximum score	Candidates score
A	1-15	40	
B	16-20	60	
Total score		100	





**SECTION A ( 40 MARKS)**

**Attempt all questions in this section.**

1. List down **four** features of a user friendly program (2Marks)

.....

.....

.....

.....

2. a) Define the term file organization. (1Mark)

.....

.....

.....

- b) Explain **two** methods of file access. (2Marks)

.....

.....

.....

.....

3. List **four** number systems that the design and organization of a computer may depend on. (2Marks)

.....

.....



.....  
.....

4. Explain the meaning of the following terms as used in computer communication (2Marks)

a) Modulation

.....  
.....

b) Remote communication

.....  
.....

5. Using one's complement, calculate  $11011_2 - 111_2$  and leave your answer in binary notation. (3Marks)

.....  
.....  
.....  
.....

6. List **three** types of computers that are classified according to the type of signal they use when functioning. (3Marks)

.....  
.....  
.....  
.....



7. In relation to DTP, explain the meaning of (2Marks)

a) Pasteboard

.....  
.....

b) Master page

.....  
.....

8. Give **two** main functions of a primary key in a database. (1Mark)

.....  
.....  
.....

9. Differentiate between LPT ports and COM ports as used in Computer Printers.  
(2Marks)

.....  
.....  
.....  
.....

10. a) Define the term Cyber space. (1Mark)

.....  
.....

b) Give **three** components of a virtual reality system and state their use. (3Marks)

.....



.....

.....

.....

11. Highlight any **two** ways in which computers are used as industrial systems. (2Marks)

.....

.....

.....

12. i) Indicate the type of cell reference depicted by the following. (3Marks)

a) **\$H\$5**

.....

b) **H \$ 5**

.....

c) **H 5**

.....

ii) Give **three** uses of spreadsheets in a government office concerned with carrying out national census (3Marks)

.....

.....

.....

.....

.....



- 13.** The Chairman IEBC has called upon a System Analyst to implement an electronic voting system. He intends to use voter’s fingerprints, Identity cards and voter’s cards as security measures to ensure free and fair elections. Recommend with reasons four input devices that they should use/buy. **(4Marks)**

.....

.....

.....

.....

.....

- 14.** State any **four** security control measures that can be taken to detect and protect computer systems against computer crimes. **(2Marks)**

.....

.....

.....

.....

- 15.** List **four** features of Electronic mail **(2Marks)**

.....

.....

.....

.....



**SECTION B ( 60 MARKS)**

Answer questions 16 and any other three questions from this section

16. a) Define the following terms as used in programming. (2Marks)

i) Assembler

.....  
.....

ii) Monolithic program

.....  
.....

b) With the aid of flowchart segments, highlight two differences between the **REPEAT....UNTIL** and **WHILE.....DO** statement structures. (4Marks)

.....  
.....  
.....  
.....  
.....

c) Give the name and use of the flowchart symbol below. (1Mark)

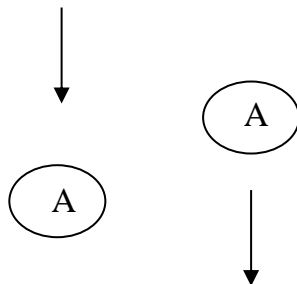

i) Name

.....

ii) Use



.....  
.....  
**(d)** State any **two** functions of programming language translators **(1 mark)**

.....  
.....  
.....  
.....

**e)** Draw a flowchart that can be used to create a program which accept a numerical pin, if the pin is equal to 0721, the program outputs , correct pin and asks for personal pin, if the pin is 1737, the output is “Admitted to UON,” 1738, the output is “Admitted to MARKU”, 1739 the output is “Admitted to KEMU” after outputting the secret message the program stops.

**(7 Marks)**



17. a) The following diagram shows the stages of developing an information system.

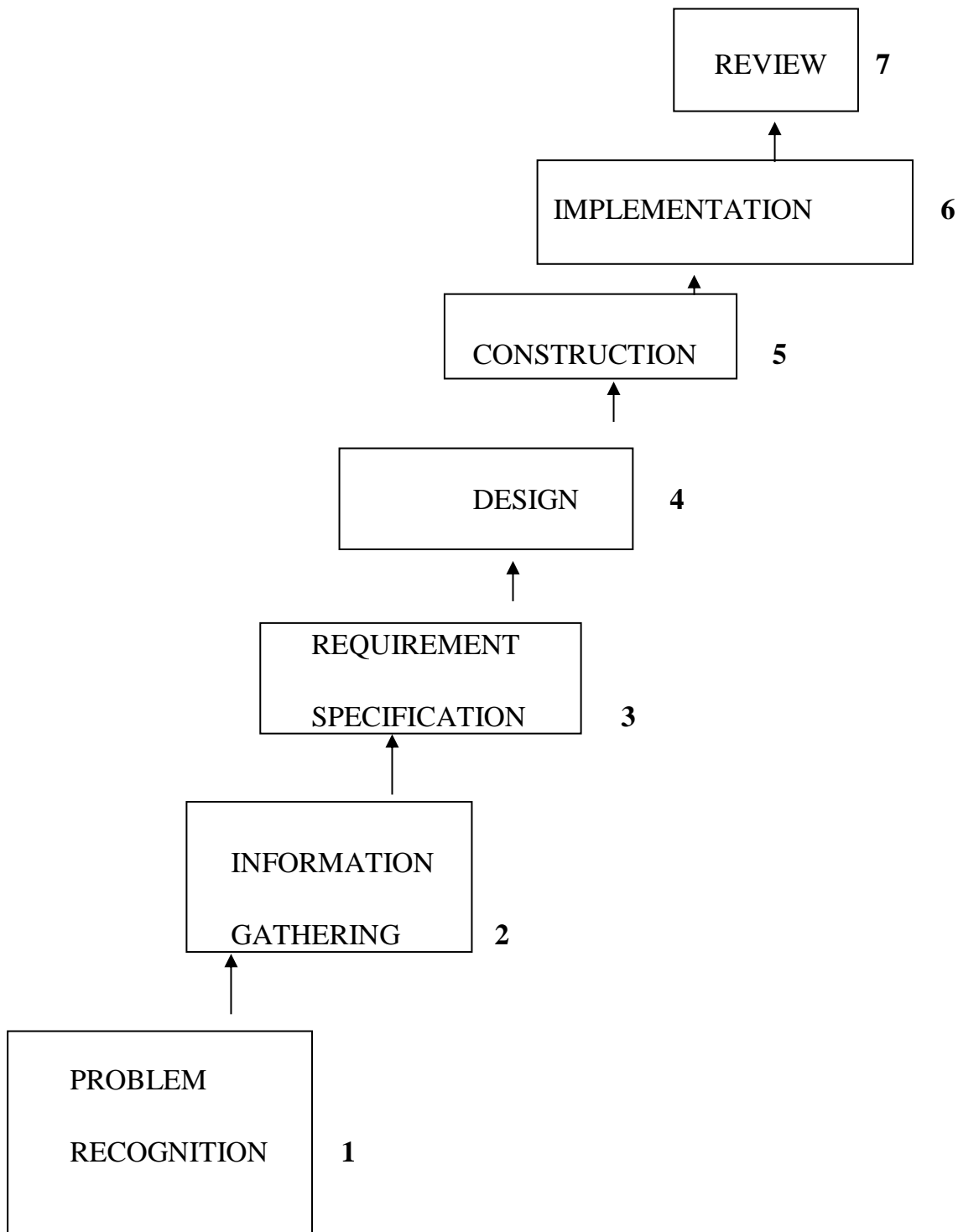

i) List any **four** methods that can be used to achieve the second stage in above.  
(2Marks)

.....

.....





.....

.....

.....

.....

**ii) List any **four** areas that have to be designed at the fourth stage. (4Marks)**

.....

.....

.....

.....

.....

**iii) Give **one** likely consequence of a project that does not stick to its schedule (2Marks)**

.....

.....

.....

.....

**b) Explain the meaning of the following system characteristics. (4Marks)**

**i) Entropy**

.....

.....

**ii) Controls**

.....

.....



c) State the **three** functions of an information system. **(3Marks)**

.....

.....

.....

.....

**18. (a)** Distinguish between the following pairs of word processing terms

**i) A widow and an orphan **(2 marks)****

.....

.....

.....

.....

**ii) Footnote and end notes **(2 marks)****

.....

.....

.....

.....

**b)** Study the Microsoft Word table below and answer question which follow

Item	Quantity	Price(sh)	Total
Bread	2	33.0	66.0
Milk(litres)	4	30.0	



**KCSE Predictions Marking Schemes - 0707550000 / 0705525657**

Potatoes		1	75.0	
Others	Cooking fat(kg)	1	180.0	A
	Salt(250 g)	1	15.0	15.0
<b>Total</b>				B

**i)** Supply a formula or function in Cell with letter **A** to calculate the total amount spent on 1 kg of cooking fat **(2 marks)**

.....

.....

**ii)** Supply a formula or function in cell with letter **B** to calculate total expenditure on all items **(2 marks)**

.....

.....

**(c)** The following is a spreadsheet relating to a farmer.

	A	B	C
1	Crop	Amount	
2	Maize	150	
3	Bean	300	
4	Cashew nuts	850	
5	Cabbages	1036	

A function =IF (B2<200, “Not Viable”), IF (B2>300, “Moderate”), IF (B2>1000, “Viable”))). Give the appropriate result returned in cells C2, C3, C4 and C5 **(2Marks)**

.....



.....  
d) Define the terms as used in databases (3Marks)

i) Attribute

.....  
.....

ii) Relationship

.....  
.....  
.....

iii) Dynaset

.....  
.....  
.....

e) List any **four** database models. (2marks)

.....  
.....  
.....

19. a) State **three** characteristics of RAM. (3Marks)

.....  
.....  
.....



.....

**b)** A computer virus is malicious software which may affect the smooth running of a computer system or carry out illegal activities in the computer.

i) Name **three** types of computer viruses and state the effect of each when it gets in to a computer **(3 marks)**

.....

.....

.....

.....

**ii)** State any **two** methods to control infection of a standalone computer by virus**(2 MK)**

.....

.....

.....

**iii)** Mr. Yugo, the Biology teacher, intends to use a multimedia system to demonstrate dissection of a frog.

What is a multimedia system? **(1 mark)**

.....

.....

.....

List **four** components that make a multimedia system **(2 marks)**

.....

.....

.....



.....  
.....

d) State any **two** softcopy output devices. (2marks)

.....  
.....  
.....  
.....

e) State **two** main ways in which secondary storage devices are classified  
(2 marks)

.....  
.....  
.....  
.....

20. a) Distinguish between guided and unguided transmission media and give one example of each.

(3Marks)

.....  
.....  
.....  
.....  
.....

b) State **two** functions of Hubs. (2Marks)

.....  
.....



.....  
.....  
c) Explain **two** different ways in which computers can enhance communication in Kenya today.

**(4Marks)**

.....  
.....  
.....  
.....  
d) State and explain how the benefits of technology were not effectively used during the 2007 general elections. **(3Marks)**

.....  
.....  
.....  
.....  
e) Explain the difference between a data Terminal Equipment (DTE) and Data Circuit – terminating Equipment (DCE) and give examples of each. **(3Marks)**



# KCSE 2021 PREDICTION

NAME..... INDEX NO.....

SCHOOL..... SIGN.....

DATE.....

451/2

## COMPUTER STUDIES

Paper 2  
(PRACTICAL)

2 ½ hours

### Instructions to Candidates

1. Type your name and index number at the top right hand corner of each printout.
2. Sign and write the date of the examination below the name and index number on each printout.
3. Write your name and index number on the compact disks.
4. Write the name and version of the software used for each question attempted in the answer sheet.
5. Passwords should not be used while saving in the compact disks.
6. Answer all the questions.
7. All questions carry equal marks.
8. All answers must be saved in your compact disks.
9. Make a printout of the answers on the answer sheets provided.
10. Hand in all the printouts and the compact disks.
11. This paper consists of 4 printed pages.
12. Candidates should check the question paper to ascertain that all pages are printed as indicated and that no questions are missing.





1. (a) (i) Using a database management system, create a database file named **ANTIGUA\_ENT\_LTD** to store the data below. (1 mark)

**CommodityTable**

Commodity_ID	Commodity_Name	Retail_Cost
C10	Apple Vinegar Super	400
C20	Assorted Sandwich	300
C30	Sweetener Max	130
C40	Soda 1L	120
C50	UPS APC 2	5000
C60	Persil Detergent	130
C70	Minute maid	120
C80	Pizza XL	1000
C90	Sacho Springs water 5L	650
C100	UPS APC 1	3000

**SuppliersTable**

Supplier_ID	Supplier_Name	Town
S-11	Antigua Foods	Nakuru
S-12	Prime Fast Food	Nairobi
S-13	Gilanis Mart	Nakuru
S-14	Power Dynamics Ltd	Eldoret
S-15	Panda Energy	Nakuru
S-16	SAHICO	Kabarnet
S-17	Rio Beverages	Nakuru

**OrderTable**

Order_ID	Commodity_ID	Supplier_ID	Order_Date
101	C10	S-11	12/04/19
102	C20	S-12	22/04/19
103	C30	S-11	12/04/19
104	C40	S-11	02/05/19
105	C50	S-14	12/04/19
106	C60	S-16	22/08/18
107	C70	S-17	19/08/18
108	C80	S-12	12/04/18
109	C90	S-13	11/05/18
110	C100	S-15	15/04/18

- (ii) Create tables named: **Commodity\_Table**, **Suppliers\_Table** and **Order\_Table** in the database created in (a) to store the information above assigning appropriate data types for each field. (14 marks)

- (iii) Identify a field to be assigned as primary key for each table.

- (iv) Create relationships among the tables and enforce referential integrity. (3 marks)



(b) Capture the number of units for the Commodities as shown below in the Commodity Table. (3 marks)

Commodity_ID	No Of Units
C30	50
C10	20
C60	89
C40	18
C50	10
C20	16
C70	35
C80	5
C90	21
C100	17

(c) Create a query named **RETAILCOST** to display Commodity name, retail price, number of units, suppliers' name and calculate the total retail price for each Commodity.

(4 marks)

(d) Create a query named **CUSTOM\_QR** to display name of each Commodity, retail price and number of units ordered. The query should contain Commodities whose suppliers name start with letter "P" and Total Retail Price is between Ksh.4000 and less than Ksh.50,000.

(5 marks)

(e) Create a report named **SUPPLIERS\_RPT** to display Commodity name, suppliers' name, total retail price and date of order. (4 marks)

- Group records per suppliers' town
- Title the report as "ANTIGUA SUPPLIERS DETAILS"
- Show the Total Retail Prices per supplier.

(f) Create a report named **ORDERS\_2019** to display Commodity name, retail price, suppliers' name, town and items ordered in the year 2018 only. Show the number of suppliers.

(3½ marks)

(g) Create a pie chart to display Total Retail Prices and their respective Commodities.

(2 marks)

(h) Create a form named **COMMODITIES\_2018** used to enter data in the database to appear as shown below

(5 marks)

### ANTIGUA LTD

CommodityName	<input type="text"/>	RetailPrice	<input type="text"/>
No. of Units	<input type="text"/>	SuppliersName	<input type="text"/>
Town	<input type="text"/>	OrderDate	<input type="text"/>



(i) Print the following

(4 marks)

- **Tables:** CommodityTable
- **Queries:** RETAIL\_COST and CUSTOM\_QR
- **Reports:** SUPPLIERS\_RPT

**Question 2**

a) Launch a Desktop publishing software and set the measurements to centimeters, margins 2cm all round and paper size A4 potrait. (1½ marks)

## Data flow diagram (DFD)

A data flow diagram (DFD) is a design tool to represent the flow of data through an information system. A "context level" DFD can be used to show the interaction between a system and outside entities; it can also show the internal data flows within a system. This version is also called a context diagram. It often shows the information system as a single circular shape with no details of its inner workings: what it shows is its relationships with the external entities.

I love data flow diagram (DFD)

<p><b>F</b>or a diagram to be called a DFD, it needs to show the inner workings of an information system. The different levels of a DFD indicate how detailed it is, e.g. a Level 0 DFD is a broad overview of a system, showing hardly any detail within the system. A level 2 DFD explodes more summarised processes and shows another level of complexity within them. A level 3 or 4 DFD shows even more components opened up to show their inner details. With a</p>	<p>dataflow diagram, developers can map how a system will operate, what the system will accomplish and how the system will be implemented. It's important to have a clear idea of where and how data is processed in a system to avoid double-handling and bottlenecks. A DFD also helps management organise and prioritise data handling procedures and staffing requirements</p>
---	--

### DATAFLOWDIAGRAM

- b) Design the publication above (in page 4) as it appears and save it as **KCSE 2021 PREDICTION.(30 marks)**
- c) Format the Title “ Data Flow Diagram (DFD)” as follows: **(6 marks)**
- (i)
- **Character spacing:** 300%
  - **Font style:** Times New Roman
  - **Font size:** 13.5
- (ii) Modify the shape containing the title as follows:
- **Background :** Gradient with 17% transparency, Shading style Horizontal
  - **Border line :** Double
- d) Apply a first line indent to the first paragraph of the document. **(2 marks)**
- e) Proofread your publication. **(½ mark)**
- f) Insert your full index number as a watermark of your publication. **(2 marks)**
- g) Insert your full name as the header, Class and admission number as the footer of your publication . **(2 marks)**
- h) Insert page number at the right bottom margin of your page. **(2 marks)**
- i) Insert the Date and time created for this document after the first paragraph. **(2 marks)**
- j) Print your publication **(2 marks)**



# KCSE 2021 PREDICTION

NAME..... INDEX NO.....

SCHOOL..... SIGN.....

DATE.....

441/1

## HOME SCIENCE

Paper 1

(THEORY)

2 ½ HOURS

### Instructions to candidates

- (a) Write your **name**, **index number** and the **name** of your school in the spaces provided above.
- (b) **Sign** and **write the date** of examination in the spaces provided above.
- (c) This paper consists of 3 sections **A**, **B** and **C**. Answer **all questions in section A and B** and **any two** from section **C**. All answers must be written in the answer booklet provided.
- (d) All Answers must be written in **English**
- (e) Candidates should check to ascertain that all pages are printed as indicated and that no questions are missing.

### FOR EXAMINER'S USE ONLY

Section	Question	Maximum score	Candidates score
A	1-19	40	
B	20	20	
C	21-23	20	
		20	
<b>Total score</b>		<b>100</b>	



**SECTION A (40MKS)**

**Answer all questions in this section in the spaces provided**

1. Name three foods that can be given in the management of kwashiorkor (1½mks)

.....

.....

.....

.....

2. State 2 methods of softening hard water at home (1mk)

.....

.....

.....

.....

3. Suggest 3 reasons for using carpets in a house (3mks)

.....

.....

.....

.....

4. Mention 2 points on the importance of basting in cookery (2mks)

.....

.....



.....  
.....

**5. State 3 ways of caring for a kitchen sink (3mks)**

.....  
.....  
.....  
.....

**6. List 3 ways of improvising cleaning agents at home (1½mks)**

.....  
.....  
.....  
.....

**7. Mention 3 rights a consumer is entitled to in Kenya (3mks)**

.....  
.....  
.....  
.....

**8. Mention 2 uses of mineral fibres in clothing (2mks)**

.....  
.....



.....  
.....

**9.** Name 2 methods of incorporating fat into flour **(1mk)**

.....  
.....  
.....  
.....

**10.** List 4 categories of sewing equipment **(2mks)**

.....  
.....  
.....  
.....

**11.** State 2 causes of cracked and sore nipples when breastfeeding **(2mks)**

.....  
.....  
.....  
.....

**12.** State 2 functions of facings in garment construction **(2mk)**

.....  
.....





.....  
.....  
**13.** Mention 2 ways in which strained section of a seam can be strengthened **(1mk)**

.....  
.....  
.....  
.....

**14.** Give 2 reasons for buffing the floor after polishing **(2mks)**

.....  
.....  
.....  
.....

**15.** Suggest three precautions to observe when cleaning china cups **(3mks)**

.....  
.....  
.....  
.....

**16.** Highlight three importance's of consumer education **(3mks)**

.....  
.....  
.....  
.....



**17** Give a reason for each of the following processes in garment construction

**a)** Top stitching **(<sup>1</sup>/<sub>2</sub>mk)**

**b)** Snipping **(<sup>1</sup>/<sub>2</sub>mk)**

**c)** Binding **(<sup>1</sup>/<sub>2</sub>mk)**

**d)** Piping **(<sup>1</sup>/<sub>2</sub>mk)**

**18.** Define the term first aid **(2mk)**

.....

.....

.....

.....

**19.** State 3 qualities of a well attached hook and bar **(3mks)**

.....

.....

.....

.....



**SECTION B (20MKS)**

**COMPULSORY**

**Answer this question in the spaces provided;**

- 20** (a) Your ten year old brother is participating in the forth coming National drama festival. Describe the procedure you would follow when laundering his acrylic knitted scarf to use **(10mks)**
- b) Outline the steps you would follow to clean a porcelain wash basin to be used that day **(5mks)**
- c) Describe how you would thorough clean a terrazzo cemented latrine for use that day **(5mks)**

.....

.....

.....

.....

.....

.....

.....

.....

.....

.....

.....

.....

.....

.....

.....

.....

.....

.....

.....

.....

.....

.....

.....



**SECTION C (40MKS)**

**Answer any two questions from this section in the spaces provided**

- 21 (a) Explain five points to consider when buying sewing machine (5mks)
- b) Explain 3 points to consider when caring for a white nylon shirt (3mks)
- c) Distinguish between; (3mks)
- i) Wear and tear
- ii) A casing and a hem
- iii) Regenerated and synthetic fibres
- d) State 6 points considered when planning meals for invalids (6mks)
- e) Mention 3 ways of managing hems (3mks)
22. a) With the aid of well labeled diagrams, give the procedure you will follow to prepare and attach a round patch pocket (10mks)
- b) State 5 advantages of drawing a budget for the family (5mks)
- c) State five disadvantages of convenience foods (5mks)
23. a) Highlight six qualities of well-made stitches (6mks)
- b) i) List any 6 examples of storage facilities for clothes (3mks)
- ii) In each of the above examples, state one way of improvising them (3mks)
- c) Explain three reasons why child immunization is important to a country (6mks)
- d) Give two reasons why weaning should be done gradually (2mks)

.....

.....

.....

.....





*KCSE Predictions Marking Schemes - 0707550000 / 0705525657*

.....

.....

.....

.....

.....

.....

.....

.....

.....

.....

.....

.....

.....

.....

.....

.....



# KCSE 2021 PREDICTION

NAME..... INDEX NO.....

SCHOOL..... SIGN.....

DATE.....

441/2

## HOME SCIENCE

Paper 2

CLOTHING AND CONSTRUCTION

2 ½ HOURS

### Instructions to candidates

- (a) *This paper consists of 2 printed pages.*
- (b) *Candidates should check to ascertain that all pages are printed as indicated and that no questions are missing.*



A pattern of a boy's shirt is provided. You are advised to study the sketches, instructions and the layout carefully before you begin the test.

**MATERIALS PROVIDED:**

1. Pattern pieces:
  - A - Shirt front with facing
  - B - Shirt back
  - C - Pocket
  - D – Collar
2. Light weight plain cotton fabric 50 cm long by 90 cm wide
3. Sewing thread to match the fabric
4. One large envelope.

**THE TEST**

Using the materials provided, cut out and make up the LEFT HALF of the shirt to show the following processes.

- |   |             |
|---|-------------|
| a) Cutting out  | (14 mrks)   |
| b) Making of a double stitched seam at the shoulder                 | (8 mrks)    |
| c) Making of the side seam using an open seam                       | (8 ½ mrks)  |
| d) Preparation and attachment of the collar                         | (24 mrks)   |
| e) Preparation and attachment of the patch pocket                   | (15 ½ mrks) |
| f) Management of the hem using hemming stitches. (shirt front only) | (6 ½ mrks)  |
| g) Making of a buttonhole by hand                                   | (7 mrks)    |
| h) Overall presentation   | (6 ½ mrks)  |

At the end of the examination, firmly sew onto your work, on a single fabric, a label bearing your name and index number. Remove the needle and pins from your work, then fold your work neatly and place it in the envelope provided. Do not put scraps of fabric in the envelope.





THE LAYOUT (NOT DRAWN TO SCALE)

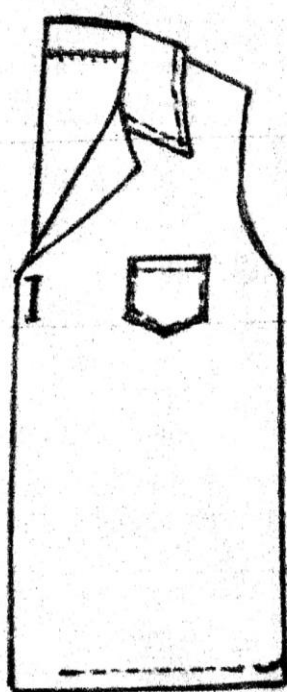
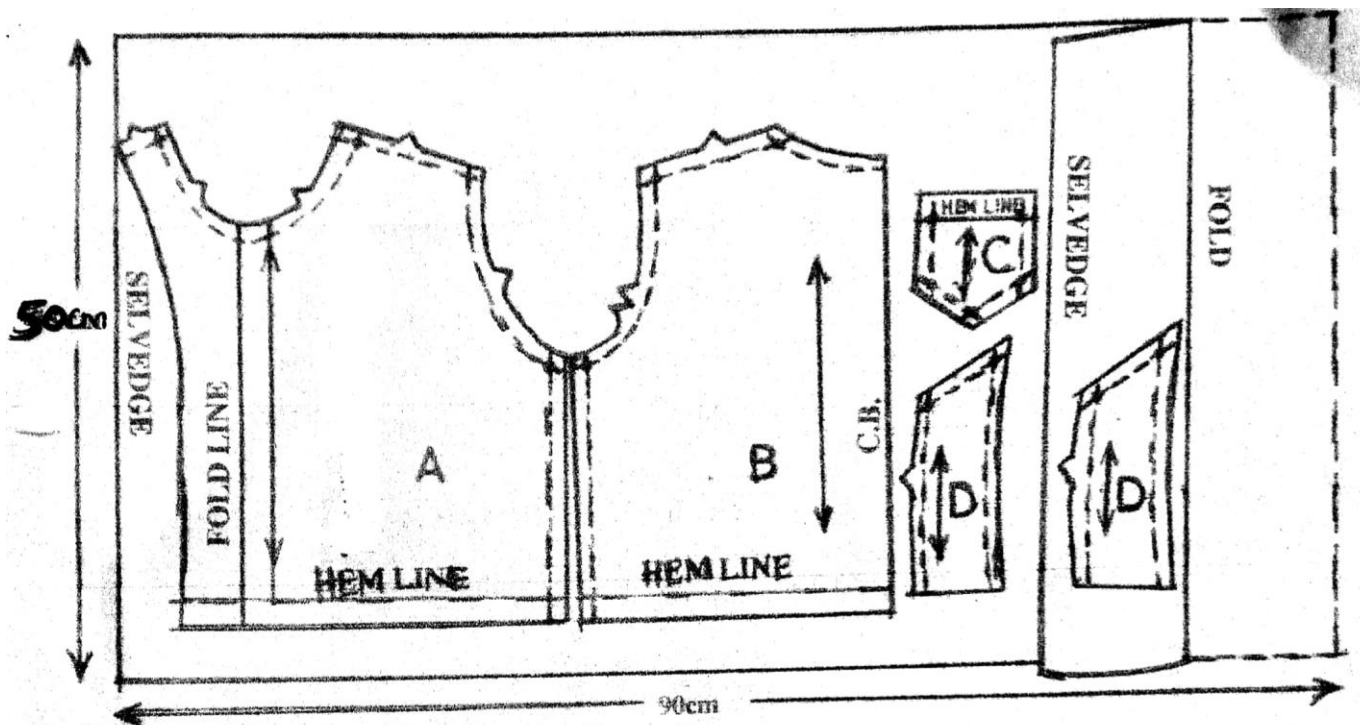

FRONT VIEW

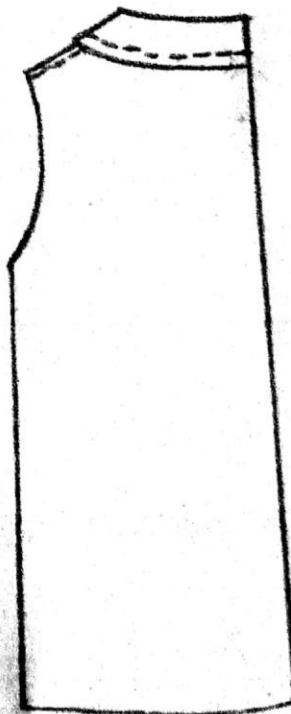

BACK VIEW

# KCSE 2021 PREDICTION

NAME..... INDEX NO.....

SCHOOL..... SIGN.....

DATE.....

441/3

## HOME SCIENCE

Paper 3

FOODS AND NUTRITION

1 ¾ HOURS

### **Instructions to candidates**

- (a) Read the test carefully.*
- (b) Text books and recipes may be used during the planning session.*
- (c) You will be expected to keep to your order of work during the practical session.*
- (d) You are only allowed to take away your reference materials at the end of the planning session.*
- (e) You are not allowed to bring additional notes to the practical session.*
- (f) Candidates should answer the questions in **English**.*
- (g) Candidates should check to ascertain that all pages are printed as indicated and that no questions are missing.*



**THE TEST**

You plan to go out on a picnic with your two friends. Using all the ingredients listed below, prepare, cook and pack two suitable items for the three of you. Include a beverage.

**Ingredients**

Self raising wheat flour/plain wheat flour

Baking powder

Milk

Arrow roots / sweet potatoes

Fat / oil

Salt

Eggs

Sugar

Cocoa / tea leaves.

**Planning Session : 30 minutes**

For each task listed below, use separate sheets of paper and make duplicate copies using carbon paper.

Then proceed as follows;

1. Identify the dishes and write the recipes.
2. Write your order of work.
3. Make a list of the foodstuff and equipment you will require.



# KCSE 2021 PREDICTION

NAME..... INDEX NO.....

SCHOOL..... SIGN.....

DATE.....

501/1

## FRENCH

Paper 1

Listening, Dictation and Composition

2 ¾ HOURS

### Instructions to candidates

- (a) Write your *name* and *index number* in the spaces provided above.
- (b) Sign and write the date of examinations in the spaces provided above.
- (c) Candidates should check to ascertain that all pages are printed as indicated and that no questions are missing.

### For Examiners use only

SECTION	MAXIMUM SCORE	CANDIDATES SCORE
I	05	
II	15	
III	25	
TOTAL		



**SECTION I: LISTENING COMPREHENSION**

*Write answers to questions 1-6 in the spaces provided.*

**PASSAGE I**

1. Il s'agit d'une .....destinée aux .....pour Kigali et qui doivent se présenter au .....à l'entrée de bus. (1 ½ mks)

**PASSAGE II**

2. (a) Que fait le professeur avant de commencer la leçon?  
.....(1 mk)
- (b) Le repas favori de Jean se compose de: (1 ½ mks)
- (i)  
.....
- (ii)  
.....
- (iii)  
.....

**PASSAGE III**

3. (a) Maurice a déjà organisé pour le .....de Marie en France. (½ mk)
- (b) Tous les deux passeront du temps dans quelles villes?  
(i) ..... (ii) ..... (1 mk)
- (c) Maurice ne sera pas avec Marie tout le temps, pourquoi?  
.....(1 mk)
- (d) Qu'est-ce que Pierre pourra donner à Marie?  
.....(½ mk)

**PASSAGE IV**

4. (a) La personne qui parle à un .....à faire à l' .....(1 mk)
- (b) Où est papa? .....(½ mk)
- (c) Michelle doit prendre .....(½ mk)
- (d) Martin doit .....pour un examen de maths. (½ mk)
- (e) Qu'est-ce que les enfants ne peuvent pas faire?  
.....(½ mk)



**PASSAGE V**

5. (a) Il s'agit des deux amies qui sont allées aux .....pour acheter des.  
.....pour fêter ..... (1½ mks)
- (b) On a fini par ..... (1 mk)

**PASSAGE VI**

6. (a) (i) Qu'est-ce que Mayaka a fait? (1mk)  
.....
- (ii) Quand? ..... (½ mk)
- (b) Où se trouve-t-il maintenant? .....  
(½ mk)
- (c) Comment trouve-t-il son nouveau quartier? (½ mk)  
.....

**SECTION II: Dictation** (5mks)

.....

.....

.....

.....

.....

.....

.....

.....

.....

.....

.....

.....

.....

.....

.....

.....

.....

.....

.....

.....

.....



.....

.....

.....

.....

.....

.....

.....

**SECTION III: Compositions**

(25

*mks)*

Write your two compositions in the spaces provided. Indicate clearly whether your choice is 1a, 1b, 2a or 2b

**1. In 120 – 150 words, write in French on;**

**Either ;**

- (a) Vous organisez une activité importante du club français dans votre école. Écrivez une lettre pour inviter l’ambassadeur / ambassadrice de France pour être le chef d’honneur.

**Or**

- (b) Vous avez invité vos camarades de classe pour une fête chez vous. Ecrivez la recette de votre plat favori.

**2. In 150 – 180 words, write in French, a composition on:**

**Either:**

- (a) Un voyage inoubliable

**Or**

- (b) Ending as follows:

Comme c’était intéressante la vie à l’école primaire!

.....

.....













# KCSE 2021 PREDICTION

NAME..... INDEX NO.....

SCHOOL..... SIGN.....

DATE.....

501/2

## FRENCH

Paper 2

Reading Comprehension and Grammar

1 ½ HOURS

### Instructions to candidates

- (a) Write your *name* and *index number* in the spaces provided above.
- (b) Sign and write the date of examinations in the spaces provided above.
- (c) Candidates should check to ascertain that all pages are printed as indicated and that no questions are missing.

### For Examiners use only

SECTION	MAXIMUM SCORE	CANDIDATES SCORE
I	15	
II	15	
TOTAL	30	



**SECTION I: Reading Comprehensions**

(15 marks)

Read the following passages and answer the questions that follow after each passage.

**PASSAGE I**

Cela nous fait peur d’imaginer l’avenir où il y aura un grave changement de climat. On attend voir les régions arides et semi-arides devenir plus chaudes et plus sèches, à cause d’une réduction de la pluie ainsi que des taux élevées d’évaporation et de transpiration. Ces tendances climatiques nous emmèneront aux changements dans la production agricole, l’écosystème et dans les variétés d’espèces différentes de plantes. Ceci endommage les problèmes de sécurité alimentaire aux niveaux régionaux et nationaux.

La direction et le taux de développement économique seront changés à cause d’une infrastructure insuffisante et une activité agricole diminuée dans les différentes régions. Le résultat sera des niveaux de pauvreté plus élevés, avec la réduction d’opportunités de travail.

1. (a) Selon le texte, le climat va changer parce que (1 mk)

i)

.....

ii)

.....

(b) Trouvez dans le texte le contraire du mot « assez » (½ mk)

.....

.....

(c) Citez deux causes du problème de sécurité alimentaire.

(i)

.....(½ mk)

(ii)

.....(½ mk)

(d) D’après le texte, quelle est la conséquence d’un manque de travail ?

.....

(½ mk)

**PASSAGE II**

Le cholera est une maladie très grave qui fait des épidémies : beaucoup de personnes sont malades en même temps. Le cholera est arrivé en Afrique en 1970 et tous les pays le connaissent. Le cholera est une diarrhée très abondante avec des vomissements : la personne malade perd des litres de son eau. Les maladies doivent être isolés et soignés très vite. Il faut leur apporter beaucoup d’eau en perfusion et en buvant (s’ils le peuvent).



Pour éviter le cholera (et toutes les autres sortes de diarrhée), il faut boire de l'eau filtrée, bouillie ou désinfectée et se laver les mains au savon avant de manger.

2. Quels sont les synonymes de ces expressions utilisées dans le texte ?

a) En meme temps.

.....

b) L'eau filtrée, bouillie ou désinfectée

.....

c) Remplissez ce paragraphe des mots appropriés : -

Pour ne pas être ..... du choléra, on ..... consommer l'eau purifiée et manger après avoir ..... les mains au savon. (1½ mks)

d) Quels sont les infinitifs dont ces mots sont formés ?

a) des vomissements ..... (½ mk)

b) bouillie .....(½ mk)

**PASSAGE III**

Imob –Kenya vous propose une villa qui vous plaira. Elle est située sur une colline, à quatre kilomètres du centre-ville, dans un quartier tranquille et sécurisant. Il y a une piscine, un garage pour quatre voitures et une clôture électrique.

Au rez-de-chaussée, il y a le salon, la salle à manger, une grande cuisine et deux chambres en suite, avec toilette et salle de bains. Au premier étage, il y a 3 chambres, toutes en suite et une bibliothèque. Le loyer n'est pas très élevé ; pour une telle habitation de grande classe, 150,000 shillings par mois, c'est très raisonnable !

En plus, c'est négociable !

3. a) Donnez les avantages du lieu décrit dans le texte : (2 mk)

.....

.....

.....

.....

.....

.....

.....

.....

b) De combien de pièces s'agit-il ? .....(½ mk)

c) Trouvez dans le passage les synonymes de : (2 mks)



- (i) calme .....
- (ii) salle de séjour .....
- (iii) location .....
- (iv) résidence .....

**PASSAGE IV**

La Suisse est toute petite ; du nord au sud, il y a 250 km, et 4 heures en voiture suffisent bien pour la traverser dans ce sens-là.

De l'est à l'ouest, en plus, on ne compte que 350 km. Pourtant, dans cette petite superficie au milieu des Alpes, on trouve une variété incroyable : de beaux villages, des sites historiques et touristiques et des musées. Pour les amateurs de bons repas, la sélection des restaurants est inépuisable. Pour les vacancières et les skieurs, il ne faut pas aller ailleurs !

4. a) Dans quel sens pourrait-on traverser la Suisse en quatre heures ?

.....

**(1mk)**

b) Selon le texte, nommez une attraction unique de la Suisse ?

.....

**(1mk)**

c) Qui sont attirés par la Suisse ?

i) .....(1/2 mk)

ii) .....(1/2 mk)

**PASSAGE V**

Nouveau Règlement de Stationnement

La préfecture de police fait savoir qu'à partir du 14 mai, il sera interdit, tous les jours sauf dimanche, les jours fériés, de laisser ou stationner un véhicule pendant plus d'une heure dans la partie centrale de la ville. Toute contravention à cette ordre sera possible d'amendes. Cette mesure a été prise pour dégager les principales voies de communication au centre-ville.

5. a) Le parking sera permissible .....(1/2 mk)

b) Pourquoi la police introduit-elle des règlements de stationnement ? **(1 mk)**

.....

..



- c) Quand la nouvelle mesure entrera-t-elle en vigueur ?  
(1/2 mk)

.....

**SECTION II: GRAMMAR**

**(15 marks)**

Beginning as indicated, complete the sentences below, making all appropriate changes. Avoid unnecessary repetitions.

- a) Vous avez déjà vu un lion ?

(1mk)

Non,

- .....
- b) Ils ont mangé des bananes que j'ai achetées hier ?

**(1 mk)**

Oui,

- .....
- c) Souvent, quand j'écris des rapports, un client téléphone.

**(1mk)**

Hier encore,

- .....
- d) Sylvie : Il est nécessaire de suivre les conseils du docteur ?

**(1 mk)**

Papa : Oui, il est important que

- .....
- e) Quand les employés voient le fou, ils s'échappent.

**(1 mk)**

C'est vrai ?

Oui, en

- .....
- f) Le policier dit aux passagers « Descendez ! »

**(1 mk)**

Qu'est-ce qu'il leur dit ?

- .....
- g) Elles ont peur des insectes.

**(1 mk)**

Les insectes





h) Je ne peux pas acheter une voiture car je n'ai pas d'argent. (1 mk)

Mais si,

.....

**Fill in each blank with ONE word only**

L'an dernier, je ..... allée à Madrid avec ..... amies. A huit ..... nous avons pris ..... train depuis Clermont – Ferrand, et après, l'avion depuis Paris. Nous sommes arrivées ..... Madrid l'après-midi. Nous ..... réservé un hôtel dans le centre. Le propriétaire nous a donné des idées de visite. Le soir, nous sommes allées manger ..... un bon restaurant. Nous avons visité beaucoup ..... musées. (4 mks)

**For each situation below, write in French an appropriate response. (3 mks)**

a) Vous voulez donner un conseil à votre ami. Qu'est-ce que vous pouvez dire ?

.....  
.....

b) Vous voulez suggérer quelque chose à votre ami. Qu'est-ce que vous diriez ?

.....  
.....

c) La technologie apporte beaucoup de problèmes chez la jeunesse. Quelle est votre opinion ?

.....  
.....



# KCSE 2021 PREDICTION

NAME..... INDEX NO.....

SCHOOL..... SIGN.....

DATE.....

502/1

## GERMAN

PAPER 1

(Listening Comprehension and Composition)

2 Hours

### Instructions to Candidates

- a) Write your name and index number in the spaces provided above.
- b) Sign and write the date of examination in the spaces provided above.
- c) This paper has two sections: I and II.
- d) You will listen to several recorded passages from a tape.
- e) Answer **ALL** the questions in the spaces provided

### For Examiner's Use Only

Section	Maximum Score	Candidate's Score
I	15	
II	20	
<b>Total Score</b>	35	



**SECTION I**  
**Listening Comprehension (15 Marks)**

**Passage 1.**

*Listen to the conversation carefully and answer the following questions.*

1. Wie heißt das Radioprogramme? (1 mark)

.....  
.....

2. Wer ist der Gast heute? (1 mark)

.....  
.....

3. Wo sind die Personen? (1 mark)

**Passage 2.**

*Listen to the conservation carefully and answer the following questions.*

4. Wie war das Wetter gestern? (1 mark)

.....  
.....

5. Was wollten Zippora und Donald gestern machen? (1 mark)

.....  
.....

6. Was machen Zippora und Donald heute? (2 marks)

.....  
.....



**Passage 3.**

*Listen to the passage carefully and answer the following questions by indicating whether the statements are true (R) or false (F).*

R	F

- 7. Sabina wohnt und studiert in Münster.
- 8. Karin hat keine Wohnung gesucht.
- 9. Es ist einfach, einen Mitbewohner zu finden.
- 10. Bis Ende Juni war kein Zimmer frei.

**Passage 4.**

11. Bei wem hat Patel die Ferien Verbracht? (1 mark)

.....  
...

12. Wer ist Raya? (1 mark)

.....  
...

13. Welche Sprachen sprechen Rayas Freunde? (1 mark)

.....  
.....

14. Nenne zwei Orte, die Patel mit Raya besucht hat. (1 mark)

.....  
...



**SECTION II (20 MARKS)**

*Write a letter or an essay of about 220-250 words on any ONE of the following topics in the spaces provided.*

1. Schreibe deinem deutschen Brieffreund/deiner deutschen Brieffreundin über Freizeitaktivitäten in deinem Heimatland und behandle dabei folgendes:
  - Welche Freizeitaktivitäten bei den Jugendlichen in deinem Heimatland.
  - Welche Unterschiede zwischen Freizeitaktivitäten in Deutschland und deinem Land.
  - Vorteile und Nachteile der Freizeit und Jugendlichen.
  - Deine Meinung über Freizeit in der Schule
  - Deine Lieblingsfreizeitaktivität.
  
2. „Deutschschulsystem ist sehr gut,“ sagte die Deutschlehrerin. Du möchtest über es lernen. Schreibe deinem deutschen Brieffreund / deiner deutschen Brieffreundin und stelle die folgenden Fragen.
  - Ob alle Kinder in die Schule gehen.
  - In welchem Alter die Kinder in die Schule kommen.
  - Welche andere schulische Aktivitäten außerhalb des Unterrichts in die Schule gibt.
  - Was ist ganz wichtig im Unterricht in Deutschland
  - Welche Möglichkeiten haben die Kinder.
  
3. Dein deutscher Freund/deine deutsche Freundin interessiert sich für die Jugendlichen in Kenia. Schreibe ihm/ihr über alles und erwähne folgende:
  - Ob Jugendliche in Kenia gern die Schule besuchen.
  - Wie verhalten sie sich mit ihren Lehrern
  - Welche Talente haben deine Mitschüler
  - Wie unterstützt die Schulverwaltung diese talentierten Schüler
  - Frag ihn/Sie, ob Jugendliche in Deutschland Probleme mit ihren Lehrern haben.
  
4. Schreibe die Geschichte zu Ende. Gestern war ein ganz normaler Montag. Aber gegen zwei Uhr.....





# KCSE 2021 PREDICTION

NAME..... INDEX NO.....

SCHOOL..... SIGN.....

DATE.....

502/2

## GERMAN

PAPER 2

(Grammar and Reading Comprehension)

2 ½ Hours

**Instructions to Candidates:**

- a) Write your name and index number in the spaces provided above.
- b) Sign and write the date of examination in the spaces provided above.
- c) Answer ALL the questions in the spaces provided in this question paper.

**For Examiner's Use Only**

Section	Maximum Score	Candidate's Score
I	20	
II	20	
<b>Total Score</b>	40	



**SECTION I: Grammar (20 marks)**

A. Complete the following sentences using the following conjunctions.

(*nachdem, trotzdem, denn*)

Example: Jane ist auf der Autobahn zu schnell gefahren, deshalb muss sie eine Geldstrafe bezahlen.

1. \_\_\_\_\_ du die zähne geputzt hast, ziehst du deine Kleider an.
2. Frau Otis wollte mit dem Handy nur schnell zu Hause anrufen, sie hatte vergessen, den Elektroherd auszuschalten
3. Petra ist innerhalb der Stadt nur 30km/h gefahren hat die Polizei sie angehalten.

- Use the verb “Kennen” or “wissen” in the correct form in the following sentences.

Example: Sie, wer die Frau dort am Fenster ist?

Wissen Sie, die Frau dort am Fenster ist?

4. \_\_\_\_\_ du eine sehr gute Sprachschule?
5. Ich \_\_\_\_\_ auch, dass die Lehrerinnen dort ausgezeichnet sind.
6. \_\_\_\_\_ du wo man in Nairobi gut Französisch lernen kann?

- Supply the correct form of the Reflexive Pronoun to complete the following sentences.

Example: Wir freuen uns über das Fußball spiel.

7. Warum ärgerst du \_\_\_\_\_ über das Essen?
8. Daizy und Brenda, beeilt \_\_\_\_\_, sonst verpassen wir den Zug.
9. Wir sind heute spät ins Büro gekommen und wir müssen \_\_\_\_\_ bei unserem Chef entschuldigen.





- **Complete the following sentences using the correct form of the past perfect tense (Plusquamperfekt)**

Example: Jessica war glücklich. Sie \_\_\_\_\_ endlich die  
Führerscheinprüfung (schaffen) \_\_\_\_\_.  
Jessica war glücklich. Sie hatte endlich die Führerscheinprüfung  
geschafft.

10. Weil ich das Handy \_\_\_\_\_, musste ich noch einmal nach  
Hause fahren. (vergessen)
11. Karen war wieder mal zu spät und traf ihre Kollegin nicht mehr. Sie \_\_\_\_\_  
schon \_\_\_\_\_ (losfahren)
12. Im Schlafzimmer brannte noch Licht, obwohl ich alle Lampen \_\_\_\_\_  
\_\_\_\_\_ (ausschalten)

- **Supply the correct form of the possessive pronoun derived from the personal pronoun given in brackets.**

Example: Herzlichen Dank für \_\_\_\_\_ süßen Brief aus Malawi. (du)  
Herzlichen Dank für deinen süßen Brief aus Malawi. (du)

13. Wir brauchen kein Auto, den \_\_\_\_\_ (e) Wohnung liegt in dem  
Stadtzentrum. (wir)
14. Kinder, räumt jetzt \_\_\_\_\_ (s) Zimmer auf! (ihr)
15. Es tut mir leid, ich habe \_\_\_\_\_ (e) Hausaufgabe nicht gemacht. (ich)

- **Fill in the correct simple past (Präteritum) form of the modal auxiliary verb given in brackets at the end of each sentence.**

Example: Auf der Reise nach Nairobi \_\_\_\_\_ ich die Musik in dem Bus  
nicht. Sie war zu laut!  
Auf der Reise nach Nairobi möchte ich die Musik in dem Bus nicht. Sie  
war zu laut!

16. In Form 1 \_\_\_\_\_ wir um 6 Uhr ins Bett gehen. (müssen)
17. Ihr \_\_\_\_\_ nicht allein zum Supermarkt gehen! Das war doch ganz  
klar nicht wahr? (dürfen)



18. Du \_\_\_\_\_ schon um 6 Uhr ankommen. Jetzt ist es leider zu spät  
(sollen)

- **Transform the following sentences into the passive voice.**

Example: Der Vater macht die Einkäufe. (Aktiv)

Die Einkäufe werden von dem Vater gemacht. (Passiv)

19. Deine Mutter sucht dich.

Du \_\_\_\_\_.

20. Wir verstehen alles ganz gut.

Alles \_\_\_\_\_.

21. Die Frau repariert das Dach.

Das Dach \_\_\_\_\_.

- **Complete the following sentences with the correct genitive endings.**

Example: Das ist das Fahrrad mein \_\_\_\_\_ Kind \_\_\_\_\_.

Das ist das Fahrrad meines Kindes.

22. Das Haus d \_\_\_\_\_ jungen Ehepaar \_\_\_\_\_ ist neu.

23. Die Mutter mein \_\_\_\_\_ Mann \_\_\_\_\_ ist krank.

24. Der Bruder sein \_\_\_\_\_ Vater \_\_\_\_\_ ist mein Onkel.

**I. Write sentences in the imperative mood.**

Example: Du must die Aufgaben machen.

Mach die Aufgaben!

25. Sie Müssen sofort aufhören.

.....

...

26. Du sollst deinen Laptop nehmen.

.....

...

27. Ihr sollt fleißig arbeiten.



.....  
...

**J. Complete the following sentences using the correct present tense form of the verb given in brackets.**

Example: Wer \_\_\_\_\_ heute den Deutschraum \_\_\_\_\_  
Mutinda oder Muteti? (aufräumen)  
Wer säumt heute den. Deutschraum auf?

28. Marys Mutter \_\_\_\_\_ in Mombasa. (arbeiten)  
29. \_\_\_\_\_ du Tabletten, wenn du Kopfschmerzen hast? (nehmen)  
30. Nicht so laut lachen, bitte! Das Baby \_\_\_\_\_! (schlafen)

**K. Complete the following sentences using adjectives given in brackets by supplying the correct endings for the adjectives.**

Example: Hast du schon den \_\_\_\_\_ Schulbus gesehen? (repariert)  
Hast du schon den reparierten Schulbus gesehen?

31. In Kenia gibt es oft \_\_\_\_\_ Wetter: nicht zu heiss und nicht zu Kalt. (schön)  
32. Die \_\_\_\_\_ Frau dort ist unsere ChemieLehrerin, Frau Matata.  
(wunderbar)  
33. Viele \_\_\_\_\_ Sportler in Kenia sind in der Polizei oder in der  
Armee. (erfolgreich)

**L. Ask the questions where the underlined words or phrases are the answers.**

Example: Derr Mann gibt der Frau einen Ring.  
Wem gibt der Mann einen Ring?

34. Evans betet fünf mal pro Tag.

.....  
...

35. Das ist Glorias Buch.

.....  
...

36. Der Film dauert zwei Stunden.



.....  
...

37. Mein Freund kommt aus Sudafrika.

.....  
...

**M. Complete the sentences by arranging the words in *italics* in the correct order.**

Example: Ich wollte fragen, ein Doppelzimmer, -gibt – ob – es – noch – mit  
Dusche.

Ich wollte fragen, ob es noch ein Doppelzimmer mit Dusche gibt.

38. Bitte sagen Sie mir/ .....  
*welches – ist – das lauteste zimmer.*

39. Darf ich fragen, .....  
*weckeu – der Weckdienst – ob – mich - kann*

40. Ich habe Keine Ahnung,  
.....  
*bin – ich – in dieses Hotel – wie – gekommen.*

**SECTION II: Reading Comprehension (20 marks)**

**A. Read the following passage and answer the questions that follow**

**MADRISA**

**Eine Geschichte aus den Alpen**

In Graubünden lebte einmal ein Bauer – im Sommer oben in den Bergen, im winter unten im Dorf. Es kame en Jahr, da war im Herbst noch so viel Heu übrig, dass der Bauer allein ins Dorf hinunterging. Sein Sohn aber blieb mit dem Vieh oben auf der Alp und kam nur manchmal ins Dorf herunter, wenn er kein Heu mehr hatte.



5 Als der Vater einmal längere Zeit nichts von dem Sohn gehört hatte, denn, da machte er sich Sorgen. „Es könnte ihm etwas passiert sein,” dachte der Vater, „den mein Sohn hatte nicht so viel Heu dabei.” Trotz des kalten Winters stieg er deshalb auf die Alp, um nachzusehen, ob alles in Ordnung war. Der Schnee war tief, er konnte nur mit viel Mühe gehen. Es war schon spät am Abend, als er oben ankam. Er traf seinen Sohn eben beim

10 Füttern und sah gleich, dass genug Heu da war.

„Wie kommt es”, fragte er seinen Sohn, „dass in der langen Zeit das Heu nicht weniger geworden ist! Und unsere Kühe sind so schön und geben Milch wie mitten im Sommer!”

„Pst, Vater, sei leise”, antwortete der Junge. „Guck mal da, *sie* hat das getan!” Und er zeigte auf seine Schlafstelle.

15 Da lag ein Mädchen und schlief, und ihre langen herrlichen Haare hingen über das Bett herunter und reichten bis zum Boden. „Das ist meine Madrisa. Sie bringt Pflanzen aus dem Wald mit, die mischt sie unter das Salz und gibt es dem Vieh. Und darum sind die Kühe so gut genährt, darum ist auch noch so viel Heu da und so viel Milch und Käse.”

Der Bauer sah seinen Jungen erstaunt an: „Aber... wer ist sie den, deine Madrisa?” Da

20 wachte die Fremde auf und stand langsam von der Schlafstelle auf. Mit einem traurigen Blick auf den Bauern sagte sie: Warum musstest du kommen und uns stören? Es wäre besser gewesen, wenn du deinen Sohn und mich in Ruhe gelassen hättest. Dann hätten wir das Vieh bis zum Frühling gefüttert, bis es wieder auf die Wiesen hinausgeht. Aber du bist gekommen, und nun muss ich in den Wald zurückgehen. Tschüß!”

25 Im nächsten Sommer brachte der Junge sein Vieh wieder auf die Alp. Er rief sehr oft nach seiner Madrisa und suchte nach einem Zeichen von ihr, aber es war hoffnungslos. Kein Mensch hat sie je wieder gesehen.

*Now answer the following questions using the space provided.*



**1. Warum bleibt der Sohn des Bauern in den Bergen als der Vater hinunter ins Dorf ging?**

**(1 mark)**

.....  
.....  
.....

**2. In welcher Jahreszeit spielt die Geschichte?**

**(1 mark)**

.....  
.....  
.....

**3. Wie fühlt sich der Vater als er lange Zeit nichts von dem Sohn gehört hatte? (1 mark)**

.....  
.....  
.....  
.....

**4. Ist es schwer oder einfach für den Vater, nach oben zu kommen? Warum oder nicht?**

**(1mark)**

15.....  
.....  
.....

16.....  
.....  
.....

**5. Was merkt der Vater sofort, als er oben ankommt?**

**(1 mark)**

a) .....  
.....  
b) .....  
.....

**6. Beschreib die Madrisa mit eigenen Wörtern.**

**(1 mark)**

.....  
.....  
.....  
.....

**7. Welche Hilfe hat die Madrisa der Junge Mann gegeben?**

**(1 mark)**



.....  
.....  
.....  
.....

**8. Wie reagiert der Vater darauf, dass die beiden zusammen leben? (1 mark)**

.....  
.....  
.....  
.....

**9. Wie fühlt sich die Madrisa, nachdem der Bauer sie entdeckt/sieht? (2 marks)**

.....  
.....  
.....  
.....  
.....  
.....  
.....  
.....  
.....

**B. Read the following passage and answer the questions that follow.**

**Warum Tiere nicht sprechen**

Ist die menschliche Sprache einzigartig? Ja, waren sich drei Neurowissenschaftler an einem Podiumsgespräch im Rahmen der diesjährigen BrainFair einig. Tiere kommunizieren zwar über Rufe und Signale. Nur die menschliche Sprache aber erlaubt es, abstrakte Ideen auszutauschen und sich über die Zukunft zu unterhalten. Ein Knopfdruck reicht, um die Erdmännchen zu täuschen. Verhaltensbiologin Marta Manser lässt bei ihrer Feldforschung in der Halbwüste in Südafrika die Warnrufe ihrer Artgenossen ab Tonband ertönen. Sofort huschen die um Manser herumwuselnden Artgenossen ins nächste Dickicht, auf einen Baum oder verschwinden im Erdbau. Die jeweilige Reaktion ist abhängig von der Art des



Warnrufes. Erdmännchen stoßen unterschiedliche Laute aus, wenn sie etwa einen Leopard, einen Adler oder eine Schlange als Feind erspähen. Können Tiere also sprechen? Nein, waren sich die Teilnehmenden am BrainFair-Podiumsgespräch vom Freitagabend einig – neben Marta Manser nahmen der Neuropsychologe Martin Meyer sowie Richard Hannloser, Neurowissenschaftler an der Universität Zürich und Technische Hochschule Zürich, daran teil. «Tiere kommunizieren zwar miteinander, aber sie sprechen nicht», so Manser. Tierische Kommunikation ermöglicht über Reife, Zeichen und Gerüche nur eine limitierte Anzahl Botschaften. Tiere sind zwar ebenfalls fähig, neue Laute zu lernen, wie Richard Hahnloser anhand seiner Forschung mit Zebrafinken aufzeigte. Trotzdem bleibt das Repertoire der tierischen Kommunikation stereotyp und beschränkt, so die einhellige Meinung auf dem Podium.

Die menschliche Sprache – auf Buchstaben. Silben, Wörtern und Sätzen aufbauend – erlaubt im Gegensatz zur tierischen Kommunikation schier unbegrenzte Kombinationen und Wortschöpfungen. Dies ermöglicht eine flexible Kommunikation und eine gegenseitige Bezugnahme zwischen Sender und Empfänger – bis hin zum Austausch abstrakter Gedanken und der Kreation dadaistischer Kunst. Es gibt viele Hypothesen dazu, warum der Mensch im Laufe der Evolution ein solch grosses Repertoire an Ausdrucksmöglichkeiten erlangte. Ist es die Möglichkeit, die Nahrungssuche oder andere Arbeiten zu koordinieren und aufzuteilen? Oder die Beziehung zwischen Kindern und Eltern zu vertiefen? Eine eindeutige Erklärung steht noch aus. Klar ist: Die menschliche Sprache bringt Vorteile mit sich, die zuvor in der Evolution nicht existiert haben. Noch ungeklärt ist gemäss Manser auch die Frage, ob Tierrufe willkürlicher Ausdruck von Erregung und Angst oder absichtliche Kommunikation sind. Bei Erdmännchen sei der Erregungszustand so gross, dass sie ihren Warnruf auch dann ertönen liessen, wenn keine Artgenossen in der Nähe seien, die gewarnt werden müssten, erläuterte die Verhaltensbiologin. Schimpansen hingegen würden weniger Alarmrufe von sich geben, wenn sie sehen, dass ihre Artgenossen den Feind bereits erspäht haben. Die Einzigartigkeit der menschlichen Sprache spiegelt sich auch im menschlichen Gehirn, zeigte Neuropsychologe Martin Meyer auf. Kein anderes Lebewesen besitze eine ähnlich große Zahl und dichte Anordnung von Nervenzellen und eine vergleichbare Geschwindigkeit der Signalübertragung im Gehirn.





**Answer the following questions based on the passage in the spaces provided**

1. Wie Kommunizieren Tiere?

**(1 mark)**

.....  
.....  
.....

2. Welche zwei Vorteile hat der menschlichen sprache?

**(2 marks)**

.....  
.....  
.....  
.....  
.....

3. Was Können Tiere noch lernen?

**(1 mark)**

.....  
...  
.....  
...

4. Welche Reaktion machen erdmännchen wenn sie etwas Gefährliches sehen?

**(1 mark)**

.....  
...  
.....  
...

5. Wie ist die menschliche Sprache aufgebaut?

**(2 marks)**

.....  
.....  
.....  
.....  
.....

6. Nenne zwei Hypothesen, wie die menschliche Sprache in der evolution sich entwickelte.

**(2 marks)**



.....  
.....  
.....  
.....  
.....  
.....

7. Was Könnten Tierrufe bedeuten? **(1 mark)**

.....  
.....  
.....



# KCSE 2021 PREDICTION

NAME..... INDEX NO.....

SCHOOL..... SIGN.....

DATE.....

314/1

## ISLAMIC RELIGIOUS EDUCATION

### Paper 1

2 ½ hours

#### Instructions to candidates

- a) Write your name and index number in the spaces provided above.
- b) Sign and write the date of examination in the spaces provided above
- c) This paper consists of SIX questions
- d) Answer any FIVE questions in the spaces provided at the end of question six
- e) Candidates should check the question paper to ascertain that all the questions are available
- f) Candidates should answer the questions in English

#### For Examiner's Use Only

Question	1	2	3	4	5	6	Total score
Candidate's score							



**Q1.**

- a. Give reasons why Quran was revealed in Arabic (7mks)
- b. Give reasons why the nature of revelation changed from short in Makkah to long in Madina (6 mks)
- c. Outline the conditions to be adhered to for translation of Quran to be valid (7mks)

**Q 2**

- a. Give the benefits of diacritilization of the Quran (5mks)
- b. Highlight the teachings of Suratul Hajurat (8mks)
- c. State the factors that made the compilation of the Quran easy (7mks)

**Q3**

- a. Differentiate between Hadith Qudsi and the Holy Quran (8mks)
- b. The prophet said “ whoever destroys a plant in Holderness which gives a shelter to passersby without a good reason, Allah will direct his head into hell fire”. In light of the above hadith give the Islamic teachings on the care of the environment (6mks)
- c. Give the characteristics of the golden age of hadith (period of Tabi Tabiun) (6mks)

**Q4**

- a. Describe the major forms of polytheism (8mks)
- b. Outline the effects of beliefs in the last day to the life of a Muslim (6mks)
- c. Give the importance on belief in Qadar and Qadha (6 mks)

**Q5**

- a. Differentiate between Sijdatu Shukr and Sijdatul Swalah (6mks)
- b. Describe the performance of Hajji (8mks)
- c. Explain the reasons that led to the emergence of schools of thought (madhahib) (6mks)

**Q6.**

- a. Outline the measures that can be put in place to improve Zakat collection in Kenya (8mks)
- b. Describe categories of legal acts in Islam (6mks)
- c. State the relevance of Islamic criminal law (6mks)





# KCSE 2021 PREDICTION

NAME..... INDEX NO.....

SCHOOL..... SIGN.....

DATE.....

## ISLAMIC RELIGIOUS EDUCATION

314/2

Paper 2

2 ½ hours

### Instructions to candidates

- a) Write your name and index number in the spaces provided above.
- b) Sign and write the date of examination in the spaces provided above
- c) This paper consists of SIX questions
- d) Answer any FIVE questions in the spaces provided at the end of question six
- e) Candidates should check the question paper to ascertain that all the questions are available
- f) Candidates should answer the questions in English

### For Examiner's Use Only

Question	1	2	3	4	5	6	Total score
Candidate's score							



***KCSE Predictions Marking Schemes - 0707550000 / 0705525657***

- 1. a)** Outline the basic principles of Islamic morality **(6 marks)**
- b)** Suggest ways that can help curb betting among the youth in the society **(7 marks)**
- c)** Give reasons why Muslims advocate for abstinence in the prevention of HIV/AIDS **(7 marks)**
- Q2. a)** Discuss the circumstances under which a woman can seek for divorce **(6 marks)**
- b)** Explain the significance of Wasiyyah (will) **(6 marks)**
- c)** Discuss the causes of increased domestic violence in the society **(8 marks)**
- Q3. a)** Discuss the rationale behind the prophet's polygamous marriage **(6 marks)**
- b)** Give the reasons why the family is considered the foundation of the Islamic society **(6)**
- d)** State the conditions necessary for contracts and agreements to be valid in Islam **(8 marks)**
- Q4. a)** Describe **FIVE** lessons Muslim youth can learn from the battle of khandaq **(10 marks)**
- b)** Discuss the effects of Islamic culture on the Kenyan society **(5 marks)**
- c)** Explain the reasons that led to the downfall of the Fatimid Dynasty **(5 marks)**
- Q5. a)** State the reforms introduced by Khalifa Umar bin Abdulaziz of the Umayyad Dynasty **(7marks)**
- b)** Discuss the challenges faced by Muslims in the spreading of Islam in Kenya **(7 marks)**
- c)** Highlight the reforms introduced by khalifah Umar binul Khatwab in the Muslim army **(6marks)**
- Q6. a)** Outline the objectives of the Muslim brotherhood (Ikhwanul Muslimin) established by Hassan Al Banna in Egypt **(6 marks)**
- b)** Discuss the achievements of Sheikh Abdullahi Swaleh Al Farsy **(7 marks)**
- c)** Explain the various contributions made by Muslim scholars in Science **(7 marks)**







# KCSE 2021 PREDICTION

NAME..... INDEX NO.....

SCHOOL..... SIGN.....

DATE.....

447/1

## POWER MECHANICS

Paper 1

Time: 2 ½ hours

### INSTRUCTIONS TO CANDIDATES

a. Candidates should have the following for their examination.

*Drawing Instruments and drawing paper size A4.*

b. Section A- Answer ALL questions(40marks)

c. Section B- Answer Question 11 and any other three questions. (60marks)

*Candidates should check the question paper to ascertain that All the pages are printed as indicated and that no questions are missing*



**SECTION A (40MARKS)**

**1 a)**List three major components of the diesel fuel system **(3marks)**

.....

.....

.....

.....

b) Arrange the following personnel training levels in the correct order starting with the highest, (2marks)

Technician, Craftsman, Technologist, Artisan

.....

.....

.....

**2 i)** Differentiate between live and dead axle. **(2marks)**

.....

.....

.....

**ii)** Explain the following terms as used in the suspension system. **(2marks)**

a) sprung weight

.....

.....

.....

b) un sprung weight

.....

.....

.....



**3** i) State two reasons for alloying metals. **(2marks)**

.....

.....

.....

ii) For each of the following components state two measurements which should be taken during inspection. **(2marks)**

a) Crankshaft

.....

.....

b) Piston rings

.....

.....

**4** State one use of each of the following tools  
(2marks)

a) Piston ring compressor

.....

.....

b) Micrometers

.....

.....

c) stethoscope

.....

.....

d) Compression gauge

.....

.....

b) Differentiate between friction and antifriction bearings. Give one example of each type.  
(4marks)

.....

.....

.....

.....



**5** a) State one cause of each the following excessive tire tread wear patterns . ( 1mark)

i) feathered edge

.....  
.....

ii) shoulder wear

.....  
.....

e) State four physical checks that need to be carried on a car battery.  
(2marks)

.....  
.....  
.....

**6** a) State two possible causes of a clutch slip. ( 1mark)

.....  
.....

b) Give two reasons why bearings are necessary.  
(2marks)

.....  
.....

c) State two requirements for combustion in a diesel engine  
(2marks)

.....  
.....

**7** a) State two possible causes why a petrol engine would emit white or light blue smoke at its exhaust pipe( 2marks)

.....  
.....  
.....



b) Identify two advantages of a pressurized water cooling system over thermo-siphon cooling system (2marks)

.....  
.....  
.....

8 a) List two advantages of a two –stroke engine over a four –stroke petrol engine (2marks)

.....  
.....  
.....

b) State two types of fire extinguishers used to put out a burning carburetor (1mark)

.....  
.....  
.....

9a) Explain each of the following terms as used in power mechanics (3marks)

i) Detonation

.....  
.....

ii pre- ignition

.....  
.....

iii) Atomization



.....  
.....  
10 a) State two functions of each of the following vehicle systems .( 3marks)

i) suspension system

.....  
.....

ii) steering system

.....  
.....

iii) braking system

.....  
.....

**SECTION B: (60 MARKS)**

Answer question **11** and any other three questions from this section.

Candidates are advised to spend(not **more than 25 minutes**) in question **11**.

11. The figure below shows an isometric drawing of a machine component.  
Draw FULL SIZE, in first projection the following views in the drawing paper provided. 15 marks)

- a) Sectional front elevation B-B .
- b) The plan.
- c) Include 3 important dimensions.

Do not show hidden details.



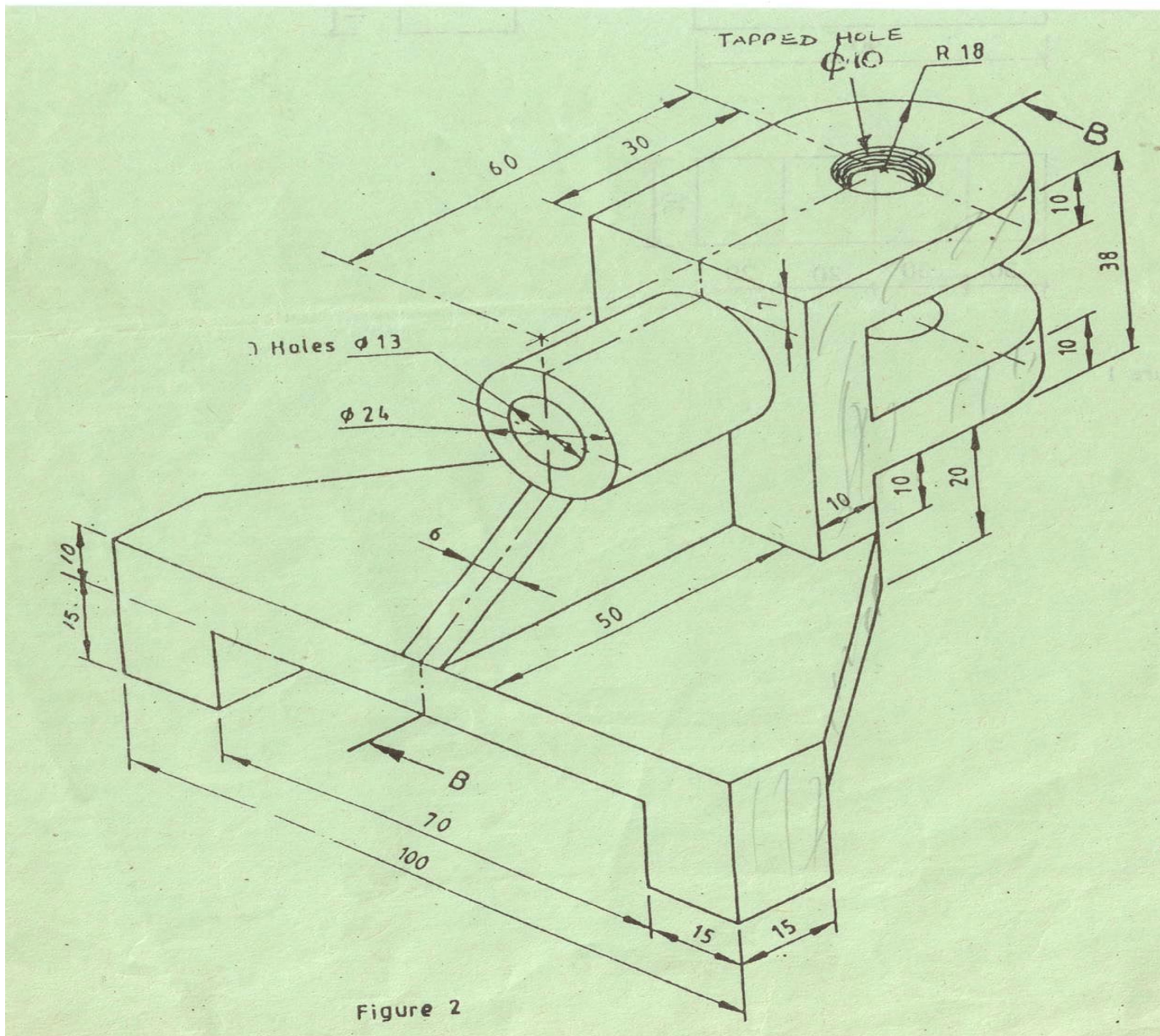

12i) State the functions of the following in a vehicle (2 marks)

a) Final drive unit

.....  
 .....

b) Clutch

.....  
 .....

ii) List **three** advantages of wankel rotary engine over the conventional reciprocating piston type. (3marks)



.....  
.....  
.....  
.....

iii) Identify four differences between full-flow and By-pass filters (2marks)

.....  
.....  
.....  
.....  
.....  
.....

iv) Using sketches explain the operation of warning light pressure gauge.

13 ) Draw and label four main parts of a ball bearing. ( 4 marks)

Draw atypical valve train diagram and label atleast six parts .( 6 marks)





- c) Using a well labeled diagram explain the operation of mechanical fuel pump.  
( 5 marks)

14 a) Draw a well-based rim and label the parts .( 3marks)

a) Outline the procedure to be followed when carrying out brake bleeding.( 4marks)

c) State the cause of the following types of wear on a tire ( 3 marks)

- i) Wear at the centre of the tread
- ii) Wear on both sides of the tread
- iii) Wear on one side of the tread

d) Using sketches distinguish between king pin inclination and castor angle (3 marks)



- e) List down **four** advantages of the independent front suspension over the solid I –beam axle.( 2 marks

15 a) State the function of the following in a cooling system.(3 marks

- i) Thermostat
- ii) Pressure valve
- iii) Vacuum valve

b) List four types of manual steering boxes sketch and explain the operation of one of them. (12 marks)



# KCSE 2021 PREDICTION

NAME..... INDEX NO.....

SCHOOL..... SIGN.....

DATE.....

447/1

## POWER MECHANICS

Paper 2

Time: 2 ½ hours

### INSTRUCTIONS TO CANDIDATES

- 1 There are ten stations in this examination.
- 2 Candidates are allowed 15 minutes at each station .
- 3 At each station ,candidates are not allowed to either review the previous station work or read instructions for other stations.
- 4 Write your name and index number in the space provided at the top of this page .
- 5 Attempt all the exercise in each station.
- 6 All dimensions in millimeters.

*Candidates should check the question paper to ascertain that All the pages are printed as indicated and that no questions are missing*



## STATION 1

*Instructions:*

The figure below shows a piston assembly of a single cylinder engine. In the space below, sketch an exploded view of the assembly and label all the parts. (10 marks)



## STATION 2

*Instructions*

The figure below shows a shaped block drawn in third angle orthographic projection. In the space provided below, draw the oblique view of the block in good proportion.( 10 marks)

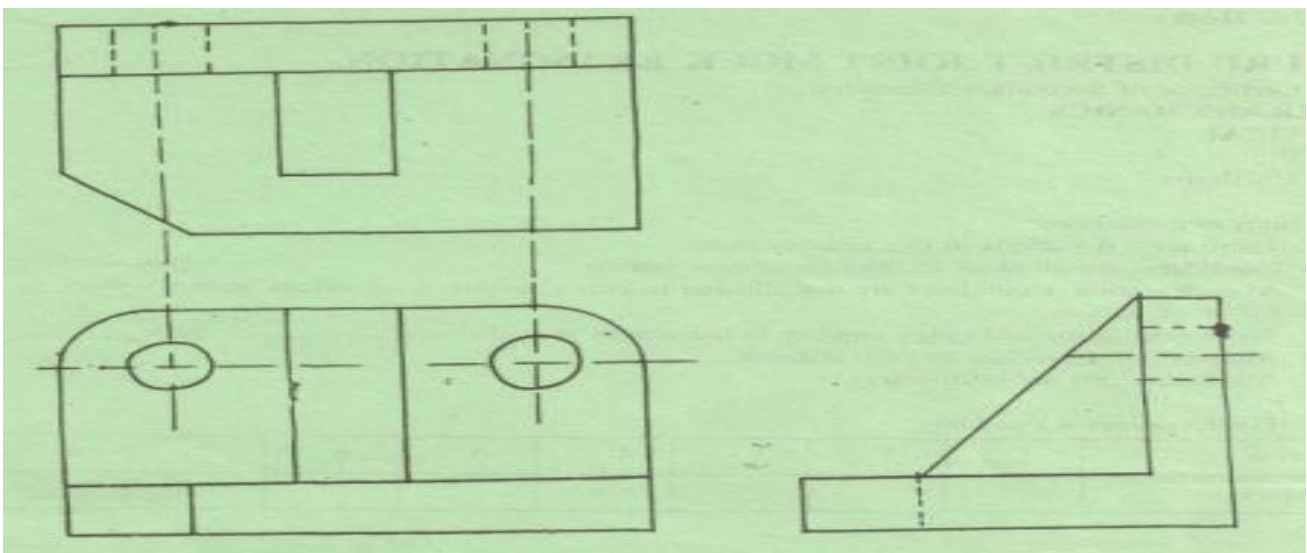

### **STATION 3**

*Instructions:*

From the manual provided, look for and record all the information required to complete the following table for models HONDA G35 (APPENDIX A) and CLINTON ENGINE (VS 2100)(10 marks)

HONDA G35 (Standard)

- 1.Exhaust valve stem O/D .....
2. Valve spring free length .....
3. spark plug gap. ....
4. Piston O/D at skirt .....
5. Cam height .....

CLINTON VS 2100

1. Carburetor float setting .....max
2. Ring end gap in cylinder .....max
3. Spark plug gap .....min
4. Piston O.D. at skirt .....min
5. Point setting .....

### **STATION 4**

*Instructions*

Make a good proportion sketch of a two-leading shoe design of a drum brake on the space provided below and also label it .



## **STATION 5**

*Instructions:*

Identify the tools labeled A to J and state the use of each. (10 marks)

TOOL	NAME	USE
A		
B		
C		
D		
E		
F		
G		
H		
I		
J		

## **STATION 6**

*Instructions*

Using the conventional ignition system components and the wires provided. Connect a complete ignition circuit as found in a vehicle.(10 marks)

Let the examiner inspect your work and disconnect the circuit.



## **STATION 7**

*Instructions*

The single cylinder engine provided has a clearance volume of 48cm<sup>3</sup>.

- i) Measure the bore.....mm
- ii) Measure the stroke.....mm

Calculate iii) the cubic capacity of the engine

iv) The compression ratio of the engine

v) The amount of fuel the engine consumes in 10 minutes if its air fuel ratio is 15:1 and the engine is running at 1200 has a volumetric R.P.M and efficiency of 80%.

## **STATION 8**

*Instructions:* Identify the components numbered 1 to 10 and complete the table given below. (10 marks)

NO.	Name of component	one use
1		
2		
3		
4		
5		
6		
7		
8		



9

10

## **STATION 9**

### *Instructions*

The engine provided has faults in its basic system indicated below. Identify the faults and state the effect of each on the performance of the engine. (10 marks)

SYSTEM	FAULTS	EFFECTS
--------	--------	---------

- a) Fuel
- b) Ignition
- c) Lubrication
- d) Cooling
- e) Exhaust

## **STATION 10**

### *Instructions*

On the gas welding equipment provided: a) identify the parts labelled A to E

A

B

C

D

E

b) Light the equipment and set the torch to a carburizing flame.

(NOTE: The regulator pressures are already set).

Let the examiner check your work. **(10 marks)**





# KCSE 2021 PREDICTION

NAME..... INDEX NO.....

SCHOOL..... SIGN.....

DATE.....

311/1

## HISTORY & GOVERNMENT

Paper 1

2 ½ HOURS

### Instructions to candidates

- (a) Write your **name**, **index number** and the **name** of your school in the spaces provided above.
- (b) **Sign** and write the **date** of examination in the spaces provided above.
- (c) This paper consists of **THREE** sections A, B and C
- (d) Answer **ALL** questions in section A (25 marks)
- (e) Answer any **THREE** questions in section B (45 marks)
- (f) Answer any **TWO** questions in section C (30 marks)
- (g) All answers must be written in the answer booklet provided.
- (h) Candidates should check to ascertain that all pages are printed as indicated and that no questions are missing.
- (i) Candidates should answer all the questions in **English**

### For Examiner's Use Only

SECTION	MAXIMUM SCORE	CANDIDATE'S SCORE
A	25	
B	45	
C	30	
<b>TOTAL SCORE</b>	100	



**SECTION A. 25 MARKS**

**Answer all the questions in this section**

1. Identify one method used by the archeologist to determine the age of artifacts. **1 mk**

.....  
.....

2. Give two social reasons for the migration of the Nilotes into Kenya. **2mks**

.....  
.....

3. Identify one role of the Njuri Ncheke among the Ameru of Kenya in the pre-colonial period. **1mk**

.....  
.....

4. Give two written evidences of contact between the Kenyan coast and the outside world. **2mks**

.....  
.....

5. Identify two natural factors that facilitated the coming of early visitors to the Kenya coast before the 1500AD . **1mk**

.....  
.....

6. Name the Portuguese commander who led in the conquest of the east African coast between 1500and 1511AD **1 mk**

.....  
.....



**7.** Identify two characteristics of a good constitution **2mks**

.....  
.....

**8.** Name the treaty that marked the end of the scramble and partition of East Africa **1mk**

.....  
.....

**9.** State one settler grievance that led to the signing of the Devonshire white paper of 1923. **1mk**

.....  
.....

**10.** Mention two factors that led to African influx into urban centers during the colonial period. **2mk**

.....  
.....

**11.** Identify two economic challenges encountered by Kenyatta at independence. **2mks**

.....  
.....

**12.** State two ways in which the government of Kenya uphold the rule of law. **2mks**

.....  
.....

**13.** Identify one organ of the Kenya Defense Forces. **1mk**

.....  
.....



**14.** State two pillars of Nyayoism **2mks**

.....  
.....

**15.** Identify one type of land holding in Kenya. **1mk**

.....  
.....

**16.** Identify one function of the deputy governor. **1mk**

.....  
.....

**17.** Mention one type of fund in which government revenue is deposited. **1mk**

.....  
.....



**SECTION B. 45 MARKS**

**Answer any three questions in this section**

- 18.** a) Apart from the Maasai, name three other groups that make up the plain nilotes. **3mks**
- b) Describe the political organization of the somali during the pre colonial period **12mks**
- 19.** a) List three methods used by the Europeans to occupy Kenya during the colonial period. **3mks**
- b) Explain the consequences of the Luo mixed reaction during the colonial period. **12mks**
- 20.** a) Highlight three levels of the colonial education in Kenya. **3mks**
- b) Explain six reasons why settlers farming was encouraged during the colonial period. **12mks**
- 21.** a) State three characteristics of early political organizations in Kenya. **3mks**
- b) Discuss six factors that facilitated the Mau Mau war with the British during the colonial period. **12mks**



**SECTION C. 30MKS**

*Answer any three questions in this section*

22. a) give three ways in which citizenship by registration can be revoked. 3mks  
b) Explain six factors that promote national unity in Kenya. 12mks
23. a) state three disadvantages of democracy.3mks  
b) Discuss the functions of the Kenya national human rights and equality commission. 12mks
24. a) Identify the composition of the Senate. 3mks  
b) Explain six powers of the Kenyan president. 12mks



# KCSE 2021 PREDICTION

NAME..... INDEX NO.....

SCHOOL..... SIGN.....

DATE.....

311/2

## HISTORY & GOVERNMENT

Paper 2

2 ½ HOURS

### Instructions to candidates

1. Write your **name**, **index number** and the **name** of your school in the spaces provided above.
2. **Sign** and write the **date** of examination in the spaces provided above.
3. This paper consists of **THREE** sections A, B and C
4. Answer **ALL** questions in section A (25 marks)
5. Answer any **THREE** questions in section B (45 marks)
6. Answer any **TWO** questions in section C (30 marks)
7. All answers must be written in the answer booklet provided.
8. **Candidates should check to ascertain that all pages are printed as indicated and that no questions are missing.**

### For Examiner's Use Only

SECTION	MAXIMUM SCORE	CANDIDATE'S SCORE
A	25	
B	45	
C	30	
<b>TOTAL SCORE</b>	100	



**SECTION A (25 MARKS)**

*Answer ALL questions from this section*

1. Identify **one** limitation of archeology as a source of information in history (1 mk)

.....  
.....

2. State **two** distinct features of Homo erectus (2mks)

.....  
.....

3. Identify **two** types of irrigation methods used by early Egyptians (2mark)

.....  
.....

4. Identify **one** main item of trade from west Africa during the trans-Atlantic trade (1 mk)

.....  
.....

5. Mention **two** factors to consider before sending an effectives message (2marks)

.....  
.....

6. What is the **main** advantaged of cell phone (1 mk)

.....  
.....





7. State **one** factor that led to the decline of Kilwa (1 mk)

.....  
.....

8. Identify **one** function of Lukiiko in the Buganda kingdom in 19<sup>th</sup> century (1 mk)

.....  
.....

9. Give **two** importance of Odwira festival in the Asante kingdom (2 mks)

.....  
.....

10. Mention **one** country in Africa that was not colonized by European powers (1 mk)

.....  
.....

11. Identify **two** communes where the assimilation policy succeeded in West Africa (2 mks)

12. Give **one** reason why the United States of America was reluctant to join the First World War(2marks)

.....  
.....



**13.** Name the organ of the United Nation that promotes justice in the world **(1mk)**

.....  
.....

**14.** Identify **two** signatories of the Strategic Arms Reduction Treaty (START) **(2mks)**

.....  
.....

**15.** Give **one** organ of the League of Nations **(1mk)**

.....  
.....

**16.** Name **two** main political challenges which have faced Democratic Republic of Congo since independence **(2mks)**

.....  
.....

**17.** Identify **two** ways through which the congress checks the excesses of power by executive in the united states of America. (USA) **(2mks)**

.....  
.....



**SECTION B (45MARKS)**

**Answer any three questions from this section**

- 18** (a) Give **five** physical changes which occurred in early human beings as they evolved from ape like creature to modern man **(5 marks)**
- (b) Explain **five** effects of early agriculture in Mesopotamia **(10marks)**
- 19** (a) Identify **five** problems faced by Trans Saharan traders **(5 mks)**
- (b) Explain **five** disadvantages of railway transport **(10marks)**
- 20** (a) Give **three** social aspects of the shona during the pre-colonial period **(3 marks)**
- (b) Describe the political organization of Shona kingdom during the pre-colonial period **(12 marks)**
- 21** (a) Mention five factors that facilitated the growth of nationalism in Ghana **(5 marks)**
- (b) Explain five reasons why **FRELIMO** succeeded in its armed struggle against the Portuguese **(10 marks)**



**SECTION C (30 MARKS)**

**Answer any two questions from this section**

- 22 (a) State **three** reasons why the British used direct rule to administer Zimbabwe (3marks)
- (b) Explain **six** reasons for the failure of direct rule in southern Nigeria (12marks)
- 23 (a) State **five** aims of Economic Community Of West African States (ECOWAS) (5 marks)
- (b) Explain **five** challenges that faced the East African community (EAC) up to 1977 (10marks)
- 24 (a) State **five** functions of British Monarch (5 marks)
- (b) Explain **five** functions of the Electoral Commission of India (10 marks)



# KCSE 2021 PREDICTION

NAME..... INDEX NO.....

SCHOOL..... SIGN.....

DATE.....

312/1

## GEOGRAPHY

Paper 1

2 ¾ HOURS

### Instructions to candidates

- (a) Write your **name**, **index number** and the **name** of your school in the spaces provided above.
- (b) **Sign** and **write the date** of examination in the spaces provided above.
- (c) This paper has **two** sections **A** and **B**
- (d) Answer all the questions in section **A**
- (e) Answer **question 6** and any other **two** questions in section **B**
- (f) All answers must be written in the answer booklet provided.
- (g) Candidates should check to ascertain that all pages are printed as indicated and that no questions are missing.



**SECTION. A. 25 MARKS**

1. (a)What is Weather? (2mks)

.....  
.....

(b)Give three main methods of forecasting weather. (3mks)

.....  
.....

2. a) Differentiate between Latitude and Longitude. (2mks)

.....  
.....  
.....  
.....

b) The Local time at town x which is on longitude 30°E is 10.30 A.M. What will be the Local time at town Y which is on Longitude 15°W (3mks)

.....  
.....  
.....  
.....

3. (a) What is natural vegetation? (2mks)

.....  
.....  
.....  
.....



(b) Give three characteristics of Mediterranean vegetation (3mks)

.....

.....

.....

.....

4. (a) Define the term soil. (2mks)

.....

.....

.....

.....

(b) Give **three** factors that determine soil leaching. (3mks)

.....

.....

.....

.....

5. Give **five** conditions that favour the growth of coral. (5mks)

.....

.....



## **SECTION B**

Answer question **six** and any other **two** questions in this section

- 6.** Study the map of **Taita Hills 1:50,000 (Sheet 189/4)** provided and answer the following questions.
- a)**
- (i)** What is the name given to this type of a map. **(1mk)**
  - (ii)** Give the title of this map. **(1mk)**
- b)**
- (i)** Give the longitudinal extent of the area covered by the map. **(2mks)**
  - (ii)** Calculate the area covered by the Ronge Forest. **(2mks)**
- c)**
- (i)** Give **3** physical features found at grid square **2318**. **(3mks)**
  - (ii)** What is the bearing of point **230300** from the air photo principal point at grid square **2226**. **(2mks)**
  - (iii)** Describe the distribution of settlements in the area covered by the map. **(5mks)**
- d)**
- (i)** Using a vertical scale of 1cm represent 100 metres draw a cross-section along the line connecting point 280140 and point 370140. **(4mks)**
  - (ii)** On the cross-section mark and label the following.
    - Hill **(1mk)**
    - River **(1mk)**
    - All weather road:- bound surface. **(1mk)**





(iii) Calculate the vertical Exaggeration of the cross-section.

(2mks)

7. a) (i) What is Solar system (2mks)

(ii) Give **three** components of the Solar system. (3mks)

b) State **Five** characteristics of the sun (5mks)

c (i) What is the name used to describe the shape of the earth. (1mk)

(ii) Give the **three** forces that contribute to the shape mentioned above. (3mks)

(iii) State **Four** effects of the rotation of the earth. (4mks)

d) Describe the structure of the earth crust. (7mks)

8. (a) (i) What is desertification? (2mks)

(ii) Name **three** types of desert surfaces (3mks)

(b) Describe the **three** processes through which wind transports its load. (6mks)

c) Using a well labeled diagram, describe how a mushroom block is formed.(6mks)

d) Explain **four** ways through which desert features influence human activities. (8mks)

9. (a) (i) What is magma? (2mks)

(ii) Name **Four** types of magma. (4mks)



- (b) Briefly describe how the following features are formed.
- (i) Geyser (5mks)
  - (ii) Lava Plateau. (5mks)
- c) Explain two ways in which Volcanic Mountains positively influence human activities. (4mks)
- d) Students carried a field study on volcanic rocks.
- (i) Give **two** methods they would have used to collect data. (2mks)
  - (ii) State **three** problems that they are likely to have experienced during the field study. (2mks)
- (3mks)
10. a) i) Differentiate between an ice berg and an ice sheet. (2mks)
- (ii) Identify **Four** ways through which ice moves (4mks)
- b) Describe the following processes of glacial erosion.
- i) Plucking (4mks)
  - ii) Abrasion (3mks)



c) Describe how a glacial trough is formed.

**(5mks)**

d. Students of Gatunguru secondary school carried out a field study on glaciation on Mt. Kenya.

(i) Give **three** reasons why they conducted a reconnaissance **(3mks)**

ii) Give **three** activities they may have been involved in during the study.

**(3mks)**

iii) Formulate **one** hypothesis that would have been relevant for study. **(1mk)**



# KCSE 2021 PREDICTION

NAME..... INDEX NO.....

SCHOOL..... SIGN.....

DATE.....

312/2

## GEOGRAPHY

Paper 2

2 <sup>3</sup>/<sub>4</sub> HOURS

### Instructions to candidates

- (a) Write your *name*, *index number* and the *name* of your school in the spaces provided above.
- (b) *Sign* and write the *date* of examination in the spaces provided above.
- (c) This paper has two sections A and B
- (d) Answer all the questions in section A
- (e) Answer question 6 and any other two questions in section B
- (f) All answers must be written in the answer booklet provided.
- (g) Candidates should check to ascertain that all pages are printed as indicated and that no questions are missing.



**SECTION A (25 MARKS)**

1 (a) State two formations in which mineral ores occur. (2 marks)

.....  
.....

(b) Describe three negative effects of open cast mining on the environment. (3 marks)

.....  
.....  
.....

2 (a) What is agro-forestry? (2 marks)

.....  
.....

(b) Give three reasons why afforestation is being encouraged in Kenya. (3 marks)

.....  
.....  
.....

3 (a) List two physical factors that influence palm oil growing in Nigeria (2mks)

.....  
.....

(b) Name three pests facing tea farming in Kenya (3mks)

.....  
.....  
.....



4 (a) Give two documents from where information on population data is obtained. (2 marks)

.....  
.....

(b) Give three negative effects of low population growth in a country. (3 marks)

.....  
.....

5 (a) What is visible trade? (2 marks)

.....  
.....

(b) State three ways in which trade is of significance to Kenya. (3marks)

.....  
.....  
.....  
.....

**SECTION B (75 marks)**

*(Answer question 6 and any other two questions from this section)*

6 The table below shows the number of tourists who visited Kenya from various parts of the world in 2005 and 2006. Use it to answer questions (a) and (b).

Place of origin	2005	2006
Europe	942000	965000
Africa	120000	154000



**KCSE Predictions Marking Schemes - 0707550000 / 0705525657**

Asia	97000	128000
North America	94000	103000
Australia and New Zealand	19000	24000
All other countries	29000	41000
<b>Total</b>	<b>1301000</b>	<b>1415000</b>

- (a) (i) Which continent had the highest increase in the number of tourists visiting Kenya between 2005 and 2006? **(1 mark)**
- (ii) Calculate the percentage increase of the number of tourists From Australia and New Zealand between 2005 and 2006 **(2 marks)**
- (iii) Draw a divided rectangle 15cm long to represent the number of tourists that visited Kenya in 2006.Show your calculations. **(10 marks)**
- (b) (i) State three advantages of using divided rectangles to represent geographical data. (3 marks)
- (ii) Give four reasons why in 2005 and 2006 there were more tourists from Europe compared to those from other parts of the world. **(4 marks)**
- (c) Give five reasons why domestic tourism is being encouraged in Kenya. **(5 marks)**

- 7 (a) (i) Name three fresh water fisheries in Uganda. **(3mks)**
- (ii) Explain four reasons why fresh water fisheries are more popular than marine water fisheries in East Africa **(8mks)**
- (b) (i) Identify three types of fish caught in Japan. **(3mks)**
- (ii) Explain three problems facing fishing in Japan **(6mks)**
- (c) Compare fishing in Kenya and in Japan **(5mks)**

- 8 (a) i. State two factors that favour the development of seaport **(2mks)**
- ii. Give three limitations of air transport **(3mks)**
- (b) Describe the role played by 'matatu' transport in the economic development of Kenya **(6mks)**



**KCSE Predictions Marking Schemes - 0707550000 / 0705525657**

- (c) (i) Explain three measures the Kenyan government has taken to reduce road accidents in the country **(6mks)**
- (ii) Give three benefits Kenya will get from the construction of the standard gauge railway **(3mks)**
- (d) Your class intends to visit the Thika super highway to observe traffic flow.
- (i) State two preparations you would make for the study **(2mks)**
- (ii) Identify three problems you are likely to encounter during the study **(3mks)**

- 9 (a) Name three agricultural food processing industries in Kenya. **(3 marks)**
- (b) Explain how the following factors have favored the development of industries in Thika town:
- Proximity to Nairobi. **(2 marks)**
- Availability of water. **(2 marks)**
- The hinterland. **(2 marks)**
- (c) Explain four ways in which Kenya has benefited from industrialization. **(8 marks)**
- (d) (i) Name two towns in Kenya where motor vehicle assembling plants are located. **(2 marks)**
- (ii) Explain three factors which have favored the development of car manufacturing industry in Japan. **(6 marks)**

- 10 (a) (i) Name two non- renewable sources of energy. **(2 mks)**
- (ii) Explain four physical factors that influence the location of a hydro-electric power station. **(8mks)**
- (b) Apart from generating HEP, give three other benefits that have resulted from the construction of Masinga Dam. **(3 mks)**
- (c) State three problems facing hydroelectric power projects in Kenya. **(3 marks)**





***KCSE Predictions Marking Schemes - 0707550000 / 0705525657***

- (d) Explain three benefits that would result from rural electrification in Kenya. **(6 marks)**
- (e) In what three ways does the power shortages resulting from drought affect the industrial sector in Kenya. **(3 marks)**



# KCSE 2021 PREDICTION

NAME..... INDEX NO.....

SCHOOL..... SIGN.....

**313/1**

## CHRISTIAN RELIGIOUS EDUCATION

### Paper 1

**2 ½ HOURS**

#### Instructions to candidates

- a) Write your name, index number and the name of your school in the spaces provided above.
- b) Sign and write the date of examination in the spaces provided above.
- c) This paper consists of SIX questions
- d) Answer any FIVE questions in this paper
- e) All answers must be written in the answer booklet provided.
- f) Candidates should check to ascertain that all pages are printed as indicated and that no questions are missing.

Question	1	2	3	4	5	6
Marks						



**ANSWER 5 QUESTIONS ONLY**

- 1 (a) Give reasons why the bible is considered as the word of God. (7 marks)  
(b) Outline the attributes of God from Genesis stories of creation (6 marks)  
(c) Identify **seven** ways in which the Bible is misused in Kenya today (7 marks)
- 2 (a) State the promises that God gave to Abraham (7 marks)  
(b) Explain the importance of God's covenant with Abraham (7 marks)  
(c) Give **six** reasons why church leaders take vows before starting their mission. (6 marks)
3. (a) State **seven** functions of the temple in the Jewish Communities (7 marks)  
(b) Identify **six** ways which Solomon turned away from the covenant way of life. (6 marks)  
(d) Give **seven** factors that have led to the increase of Christian denominations in Kenya. (7 marks)
4. (a) Outline **Seven** similarities between traditional African and true prophets in the Old Testament (7 marks)  
(b) Describe the call of prophet Amos. (7 marks)  
(c) State the relevance of prophet Amos teaching on election of Israel to Christian in Kenya today. (6marks)
- 5 (a) Give **seven** characteristics of the new covenant foreseen by prophet Jeremiah. (7 marks)  
(b) Identify **seven** final reforms carried out by Nehemiah to restore the worship of God in Judah (7 marks)  
(c) Identify **six** ways in which the government of Kenya supports in the spread of the gospel. (6 marks)
6. (a) What changes have taken place in the rites of initiation in Kenya today (8 marks)  
(b) Identify the moral values taught to the youth during the initiation to adulthood.



**(6 marks)**

- (c) Give **six** reasons why female circumcision is being discouraged in Kenya today.

**(6 marks)**



# KCSE 2021 PREDICTION

NAME..... INDEX NO.....

SCHOOL..... SIGN.....

**313/2**

## CHRISTIAN RELIGIOUS EDUCATION

### Paper 2

**2 ½ HOURS**

#### Instructions to candidates

- (a) Write your **name**, **index number** and the **name** of your school in the spaces provided above.
- (b) **Sign** and **write the date** of examination in the spaces provided above.
- (c) This paper consists of **SIX** questions
- (d) Answer any **FIVE** questions in this paper
- (e) All answers must be written in the answer booklet provided.
- (f) This paper consists of **three hundred sixty printed pages**.
- (g) Candidates should check to ascertain that all pages are printed as indicated and that no questions are missing.

Question	1	2	3	4	5	6
Marks						



**ANSWER 5 QUESTIONS ONLY**

1. (a) Outline the Psalmist Prophecy concerning the Messiah *Psalms 41;9, 110;1-2* (7mks)
- (b) Identify seven activities that took place during the presentation of Jesus in the temple (7mks)
- (c) Give *six* reasons why children should take part in church activities. (6mks)
  
2. (a) Describe the healing of Centurion servant. *Luke 7:2-10* (7mks)
- (b) Explain the importance of Jesus transfiguration. (6mks)
- (c) Outline *seven* ways in which Christians can help reduce human suffering. (7mks)
  
3. (a) Identify *seven* instructions that Jesus gave the seventy two disciples when he sent them on a mission *Luke 10;1-24* . (7mks)
- (b) Describe the incident when Jesus went to pray with His disciples at the Mount Olives. *Luke 22:39-53* (8mks)
- (c) Outline *Five* activities a modern Christian can perform in order to be considered a true follower of Jesus (6mks)
  
4. (a) Give seven reasons why Jesus sent the Holy Spirit to the disciples after ascension (7mks)
- (b) Identify the fruit of the Holy Spirit as taught by St. Paul in *Galatians 5:22-23* (7mks)
- (c) Give six ways in which the church in Kenya helps to bring about unity in the country. (6mks)
  
5. (a) Identify *five* sources of Christian ethics. (5mks)
- (b) In which ways can a Christian demonstrate responsible parenthood (8mks)
- (c) Give ways in which the church strengthens the family relationships today (7mks)





***TO ALL CANDIDATES;***

***Incase A Significant Number Of Questions***

***Appear In KCSE Exam, Don't panic!***

**TAKE IT EASY**

**FOR MARKING SCHEMES**

**CONTACT**

**0707550000 / 0705525657**

***([kcsepredictions@gmail.com](mailto:kcsepredictions@gmail.com))***

