

KCSE 2022 PREDICTION

ALL SUBJECTS

SET 3

SUBJECTS PREDICTED INCLUDE;

*Mathematics, English, Kiswahili, CRE, Geography, History, Biology, Chemistry, Physics,
Agriculture, Business, Computer & Home-Science.*

**Series 3 of Detailed Comprehensive Possible Expected
set of Questions in KCSE 2021 EXAMINATIONS.**



***(AN INTENSIVE ANALYSIS OF POSSIBLE QUESTIONS IN THE KCSE
2021 EXAMS SCHEDULED FOR APRIL 2022)***

For Marking Schemes/Answers

CALL/WHATSAPP 0707550000 / 0705525657

(MWALIMU PUBLISHERS)

SUCCESS TO KCSE 2021 CANDIDATES!

KCSE 2021 PREDICTION

NAME.....

INDEX NO.....

SCHOOL.....

SIGN.....

DATE.....

232/1

PHYSICS

Paper 1

(THEORY)

2 hours

Instructions to candidates

- (a) Write your name, index number in the spaces provided above.
- (b) Sign and write the date of the examination in the spaces provided
- (c) This paper consists of **TWO** Sections: **A** and **B**.
- (d) Answer **ALL** the questions in section **A** and **B** in the spaces provided.
- (e) All working **MUST** be clearly shown.
- (f) KNEC mathematical tables and silent non-programmable electronic calculators may be used.

For examiners use only

Section	Question	Maximum score	Candidates score
A	1-13	25	
B	14	11	
	15	09	
	16	08	
	17	09	
	18	10	
	19	08	
	TOTAL SCORE	80	

©2021 The Kenya National Examinations Council

KCSE 2021 Prediction SET 3



SECTION A: 25marks

1. The figure below shows part of micrometer screw gauge with 50 divisions on the thimble scale. Complete the diagram to show a reading of 5.73mm. (2 marks)

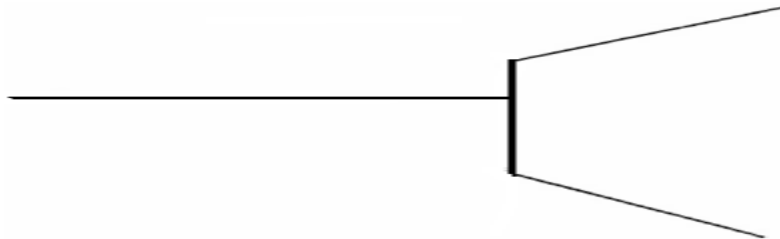

2. A bottle containing a smelling gas is opened at the front bench of a classroom. State the reason why the gas is detected throughout the room. (1 mark)

.....

3. The figure below shows beaker containing a block of ice.

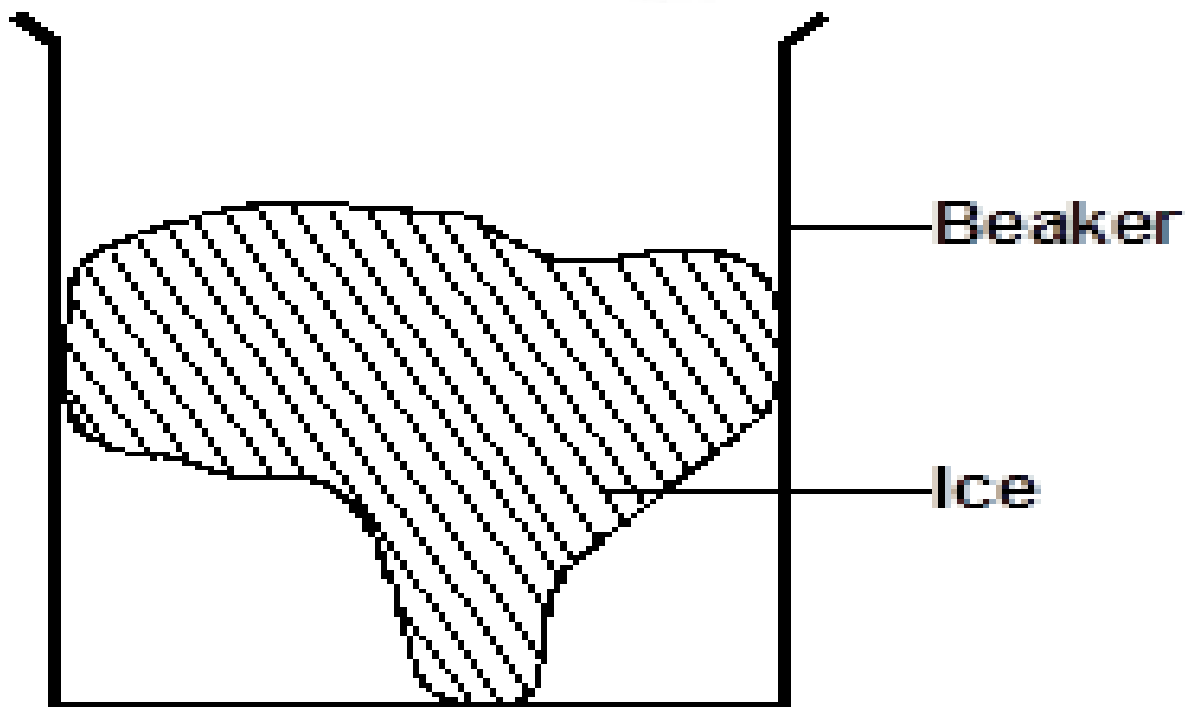

State and explain the change in stability when the ice melts. (2marks)

.....
.....
.....



4. An aero plane is moving horizontally through still air at a uniform speed. It is observed that when the speed of the plane is increased, its height above the ground increases. State the reason for this observation.

(2 marks)

.....
.....
.....

5. A steel ball of mass 0.05kg was placed on top of a spring on a level ground. The spring was then compressed through a distance of 0.2m.

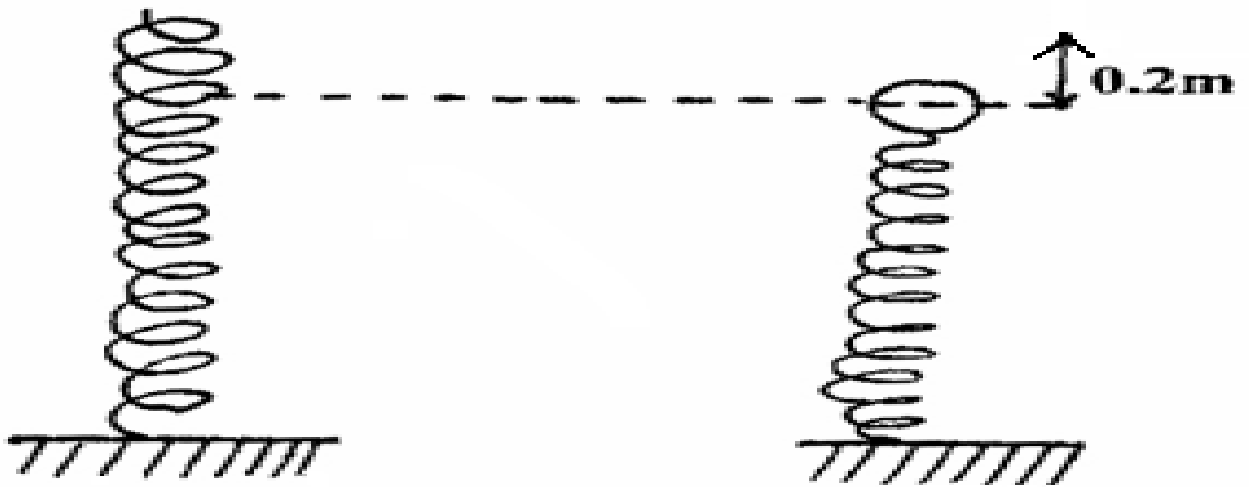

If the spring constant is 15N/m. Calculate the maximum height reached when the spring is released. (3marks)

.....
.....

6. The figure below shows a uniform metre rule of weight 3N supporting two weights. The metre rule is pivoted somewhere such that it is horizontally balanced. (Pivot not shown)

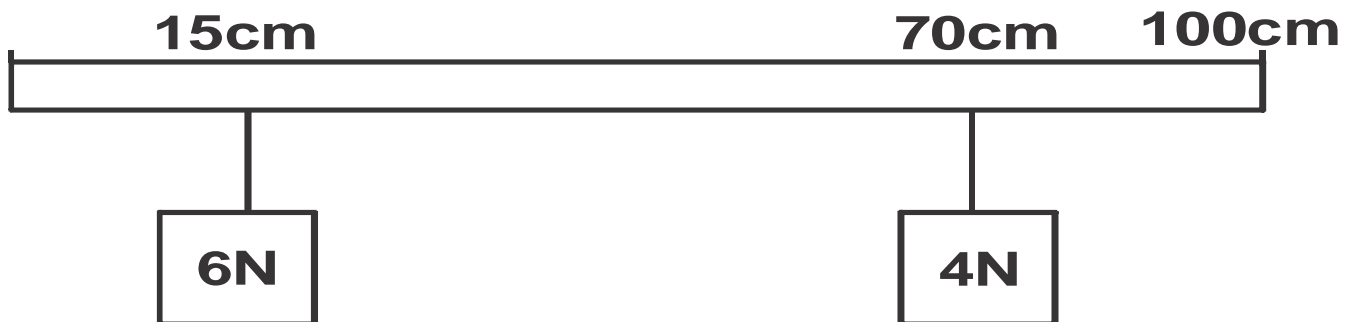

The 6N weight is at 15cm mark while the 4N weight is at 70cm mark. Determine the position of the pivot from zero cm mark. **(3 marks)**

.....

.....

7. State one environmental hazard that may occur when oil spills over a large surface area of the sea. **(1mk)**

.....

.....

8. The figure shows a flat bottomed flask containing some water. It is heated directly with a very hot flame. Explain why the flask is likely to crack. **(2marks)**

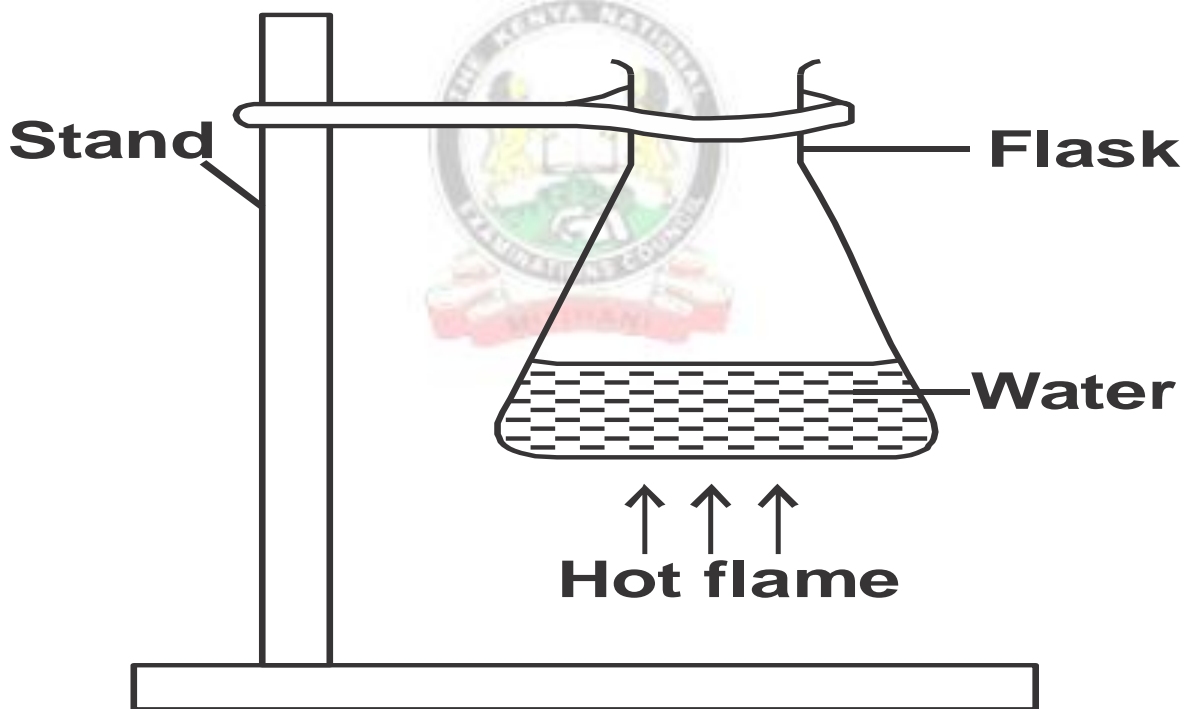

.....

.....

.....

9. The figure below shows a cylindrical container having hot water at 95°C. End A is shiny while end B is dull black. At equal distances from the container is placed two identical gas jars fitted with thermometers X and Y.

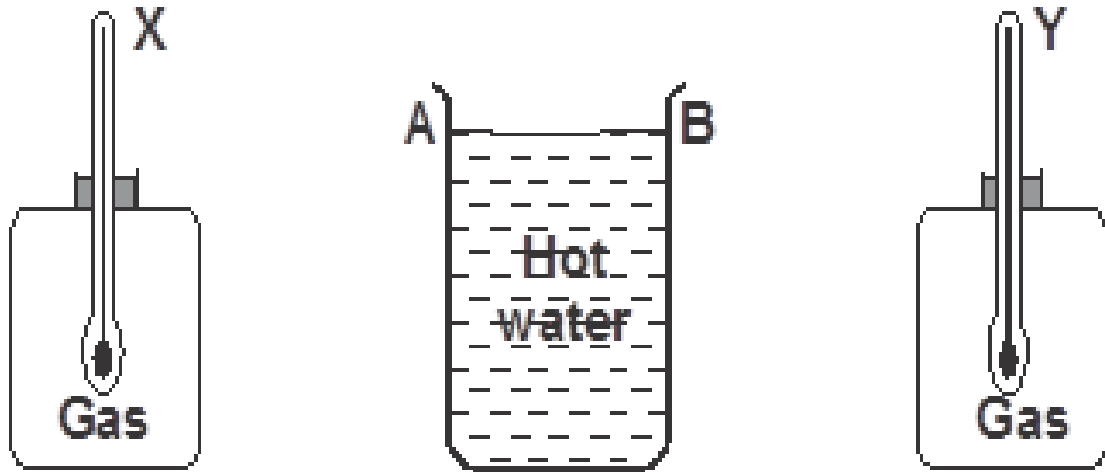

Compare the readings of the two thermometers after two minutes

(1 mark)

.....
.....

10. Give a reason for your answer in question 9 above

(1 mark)

.....
.....

11. The figure below shows the change in volume of water in a measuring cylinder when an irregular solid is immersed in it.

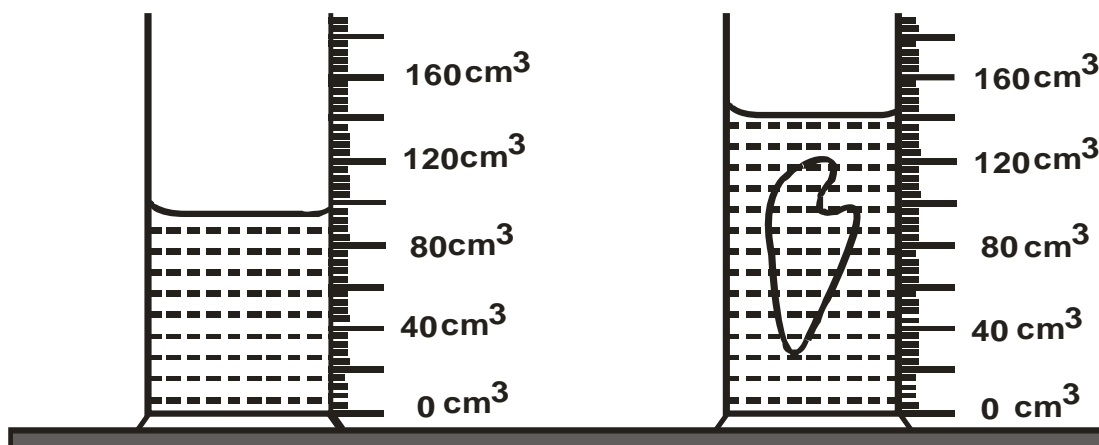

Given that the mass of the solid is 268g, determine the density of the solid in SI units. (3 marks)

.....
.....
.....

12. The following figure shows a rod made of wood on one end and metal on the other end suspended freely with a piece of thread so that it is in equilibrium.



The side made of metal is now heated with a Bunsen flame. State with a reason, the side to which the rod is likely to tilt (2 marks)

.....
.....
.....

13. The spiral springs shown in the figure below are identical. Each spring has a spring constant, $k = 300\text{N/m}$

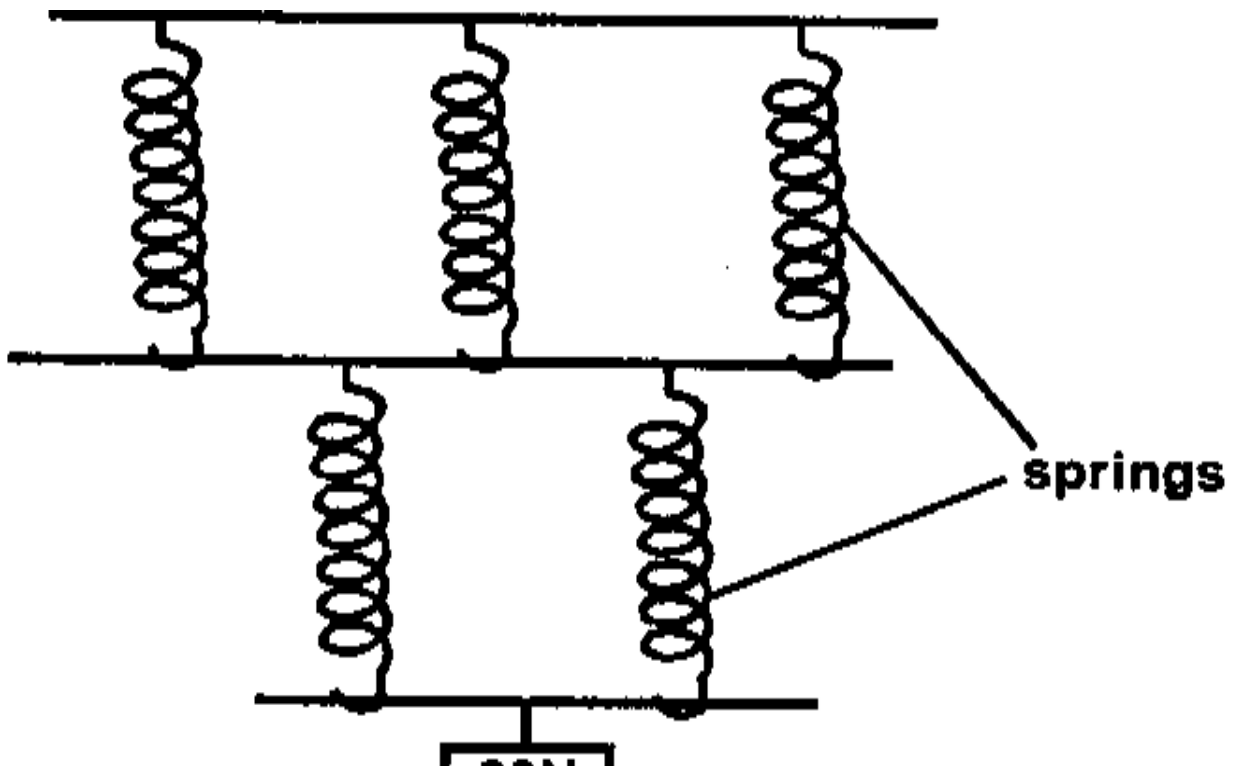

Determine the total extension of the system. (Take the weight of the cross bars to be negligible) (2 marks)

.....
.....
.....
.....

SECTION B: 55marks

14. (a) State the Archimedes principle. (1 mark)

.....
.....
.....

b) A rubber envelope of a hydrogen filled balloon having volume of 2m^3 is held in position by a vertical string as shown below.

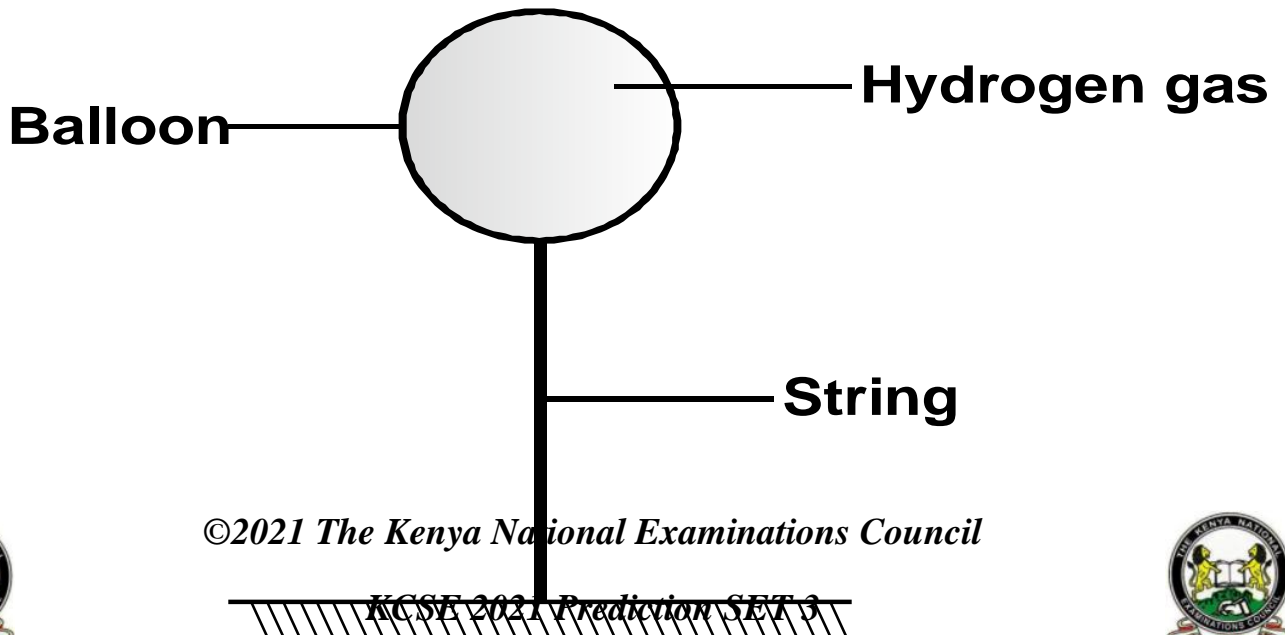

The mass of the balloon is 1.3kg. Given that density of hydrogen is 0.1kg/m^3 density of air is 1.3kg/m^3 .

Calculate;

(i) the total weight of the balloon including the hydrogen gas. **(2 marks)**

.....
.....
.....

(ii) the up thrust. **(2 marks)**

.....
.....
.....

(iii) the tension in the string. **(2 marks)**

.....
.....
.....

(c) A solid weighs 50N in air and 44N when complete immersed in water. Calculate

i) Relative density of the solid. **(2 marks)**

.....
.....

(ii) Density of the solid. **(2 marks)**



15.a) The figure below shows a displacement-time graph of the motion of a particle.

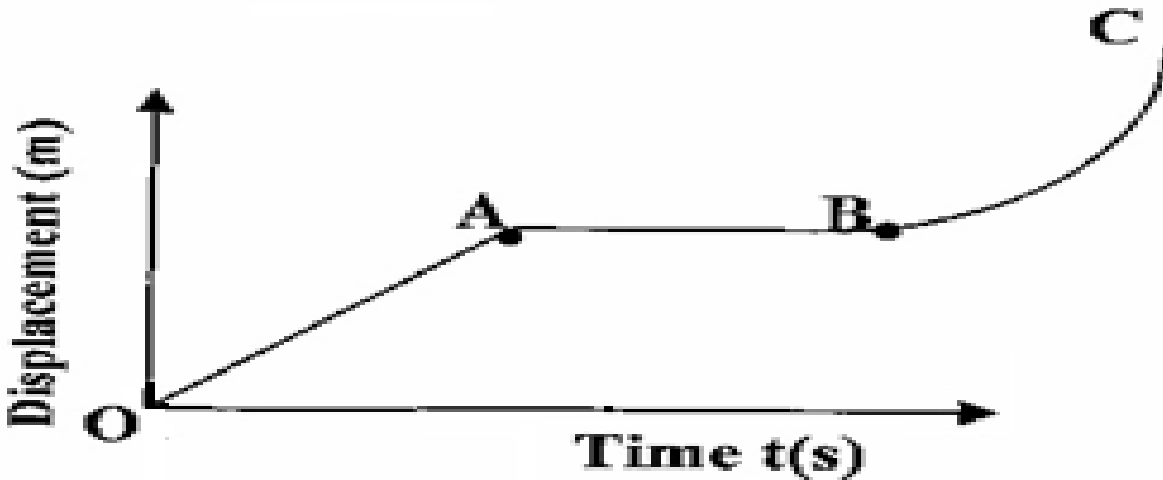

Describe the motion of the particle in the region.

(3marks)

OA.....

AB.....

BC.....

(b) State the Newton's first law of motion.

(1 mark)

c) The figure below shows a trolley moving towards a barrier at a constant velocity of 20m/s. Use this information to answer the questions that follows.

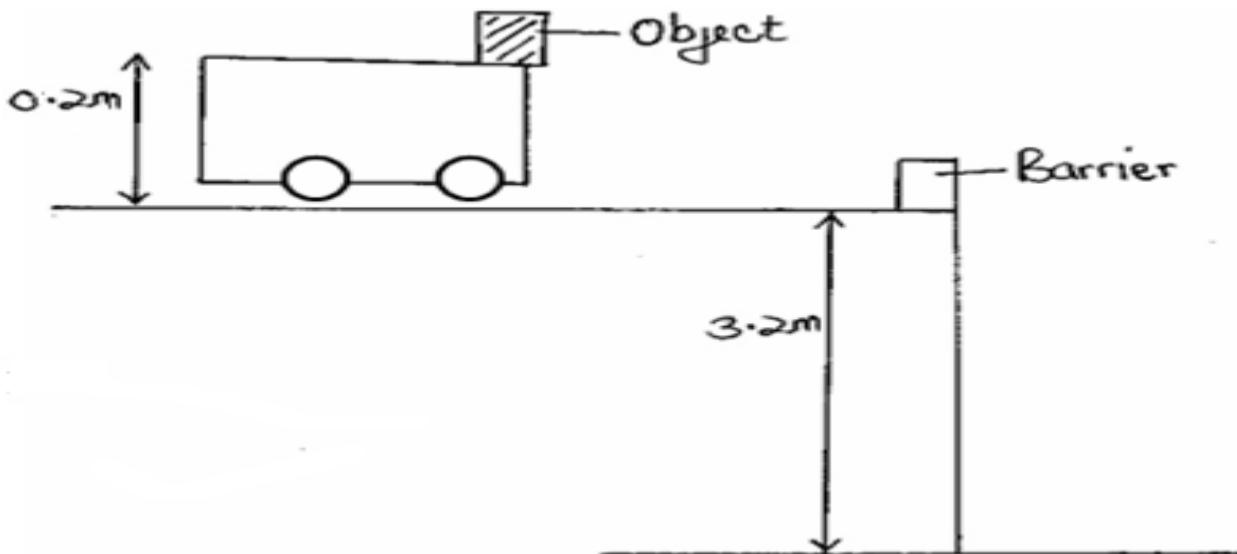

i) Sketch the path followed by the object after the impact (1mark)

ii) Give a reason why the object on the trolley flies off on impact. (1 mark)

.....
.....

iii) Determine the time taken by the object to reach the ground. (2 marks)

.....
.....

iv) Determine the horizontal distance covered by the object from the point of impact to the point where it reached the ground. (2 marks)

.....
.....
.....

16. a) What is meant by absolute zero temperature? (1 mark)

.....
.....

b) The set up below was used by a group of form three students to verify pressure law.

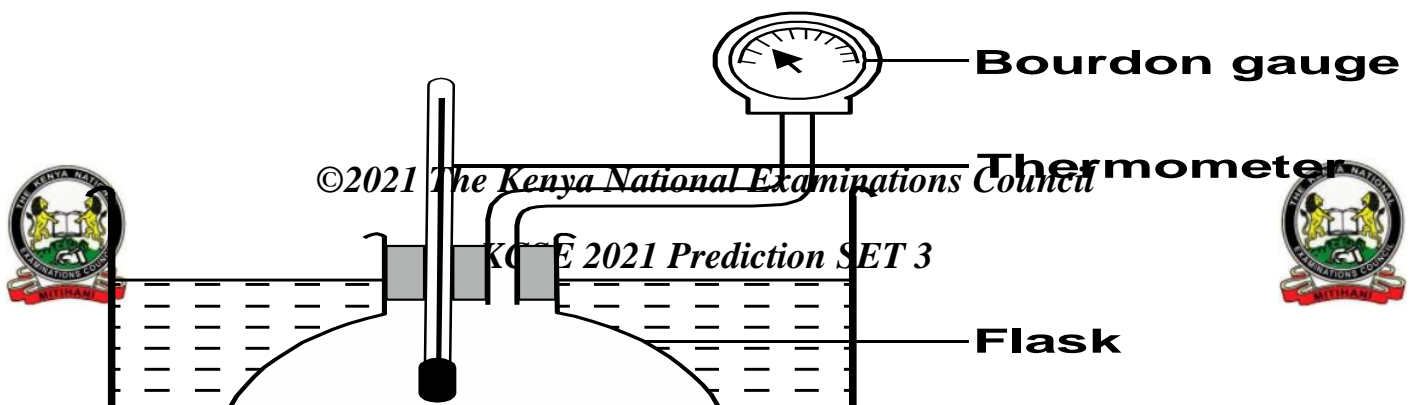

Describe briefly how the set-up can be used to verify pressure law. (4 marks)

.....
.....
.....
.....
.....

c) A 4.5cm^3 bubble released at the bottom of a dam measured 18cm^3 at the surface of the dam. Work out the depth of the dam taking atmospheric pressure to be 10^5 Pa and the density of water as 1g/cm^3 . (3marks)

.....
.....
.....

17(a) One of the factors that affect the centripetal force is the mass of the body.State another factor.(1mark)

.....
.....

(b) A mass of 400g is rotated by a string at a constant speed V in a vertical circle of radius 100cm. The tension in the string is 9.2N which is experienced at point T.

T



i) Determine the velocity V of the mass at point T. (3marks)

.....
.....
.....

ii) Determine the tension in the string at the bottom of the circle. (2marks)

.....
.....
.....

c) State two applications of circular motion (2marks)

.....
.....
.....

18. The figure below shows an inclined plane, a trolley of mass 30kg is pulled up a slope by a force of 100N parallel to the slope. The trolley moves so that the centre of mass C travels from points A to B.

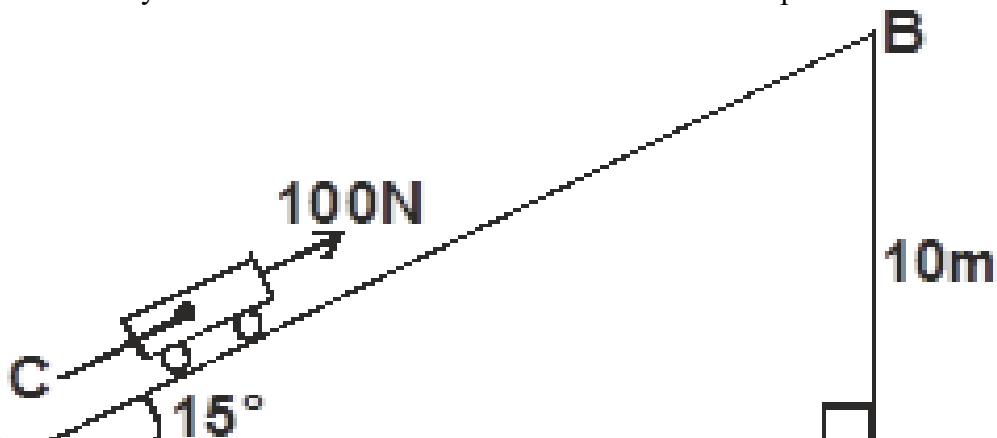

a) What is the work done on the trolley against the gravitational force in moving from A to B? **(2marks)**

.....
.....
.....

b) Determine the work done by the force in moving the trolley from A to B **(2 marks)**

.....
.....
.....

c) Determine the efficiency of the system. **(3 marks)**

.....
.....
.....

d) Determine the mechanical advantage of the system. **(3 marks)**

.....
.....
.....

19. a) Explain why it is advisable to use a pressure cooker for cooking at high altitudes. **(1 mark)**

.....
.....
.....



b) A block of metal of mass 150g at 100°C is dropped into a lagged calorimeter of heat capacity 40J/K containing 100g of water at 25°C. The temperature of the mixture is 34°C. (specific heat capacity of water = 4200J/kg/K).

Determine:

(i) Heat gained by the calorimeter. **(2marks)**

.....
.....
.....

(ii) Heat gained by water. **(2marks)**

.....
.....
.....

(iii) Specific heat capacity of the metal block. **(3marks)**

.....
.....
.....



KCSE 2021 PREDICTION

NAME.....

INDEX NO.....

SCHOOL.....

SIGN.....

DATE.....

232/2

PHYSICS

Paper 2
(THEORY)

2 hours

Instructions to candidates

- (a) Write your name, index number in the spaces provided above.
- (b) Sign and write the date of the examination in the spaces provided
- (c) This paper consists of **TWO** Sections: **A** and **B**.
- (d) Answer **ALL** the questions in section **A** and **B** in the spaces provided.
- (e) All working **MUST** be clearly shown.
- (f) KNEC mathematical tables and silent non-programmable electronic calculators may be used.

For examiners use only

A	1-13	25	
B	14	11	
	15	11	
	16	13	
	17	10	
	18	10	
	TOTAL SCORE	80	



©2021 The Kenya National Examinations Council

KCSE 2021 Prediction SET 3



SECTION A: 25marks

1. The chart below shows an arrangement of different parts of the electromagnetic spectrum.

Radio wave	A	Infrared rays	B	Ultra-violet	γ -Rays
------------	---	---------------	---	--------------	----------------

Name the radiation represented by

A (1mark)

State one use of radiation represented by B (1mark)

.....

2. An object O is placed in front of convex mirror as shown in the diagram below. Complete the diagram to locate the position of the image, 1. (3 marks)

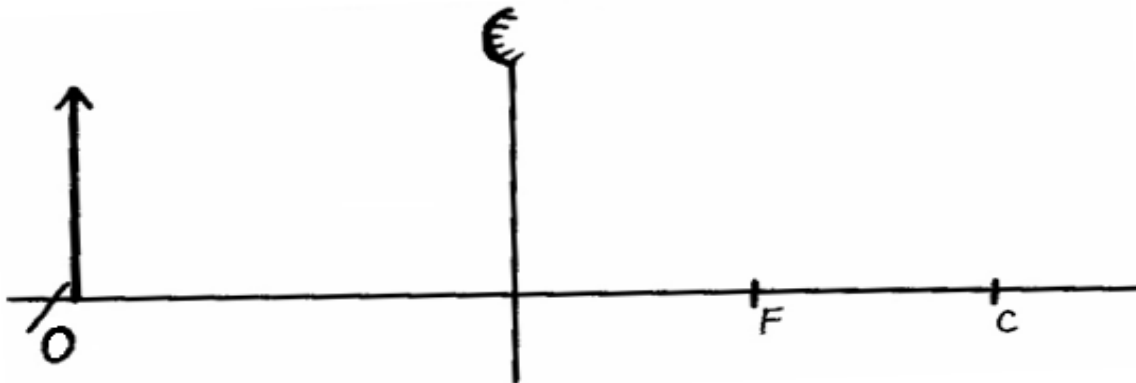

3. The figure below shows a wire carrying current whose direction is out of the paper. The wire is placed in a magnetic field.

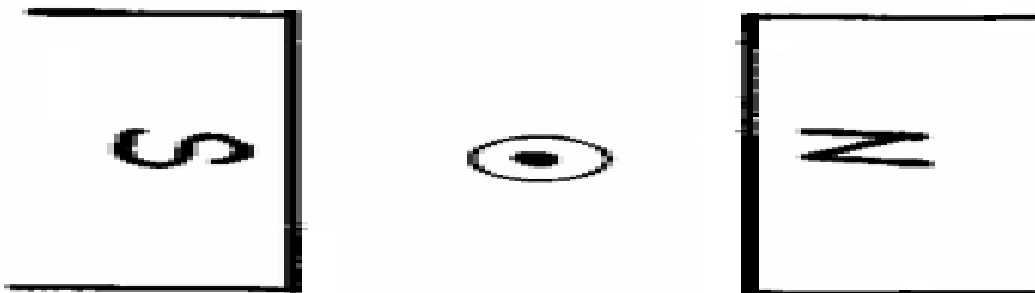

(a) Indicate on the figure the direction of the force F, acting on the wire. (1 mark)

(b) State what would be observed on the wire if the direction of the current is reversed. (1 mark)

©2021 The Kenya National Examinations Council



4. The figure below shows part of the lighting circuit of a house.

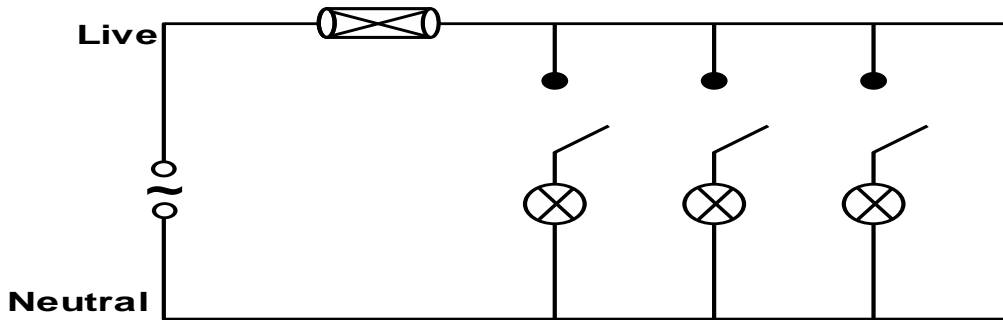

i) Give a reason why a fuse is included in the circuit.

(1 mark)

ii) If each lamp has a power of 60W at voltage of 240V. Calculate the current through one lamp when it is switched on.

(2 marks)

5. Figure 5 below shows a simple transformer connected to a 12v a.c source and an a.c voltmeter.

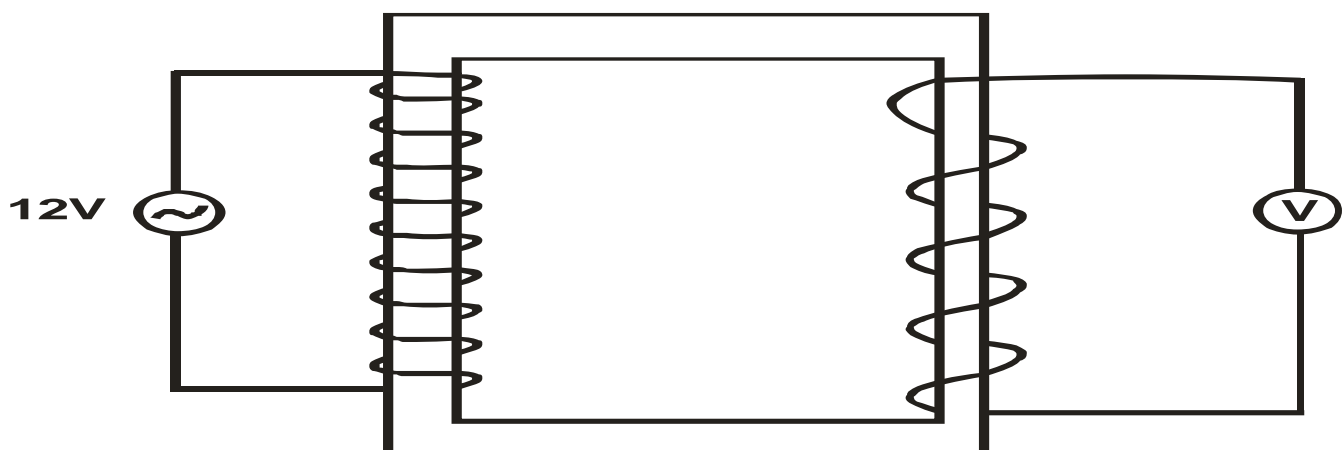

Determine the reading on the voltmeter.

(2 marks)

.....
6. The diagram shows a patient having her eyes tested. A chart with letters on it is placed behind her and she sees the chart reflected in a plane mirror.

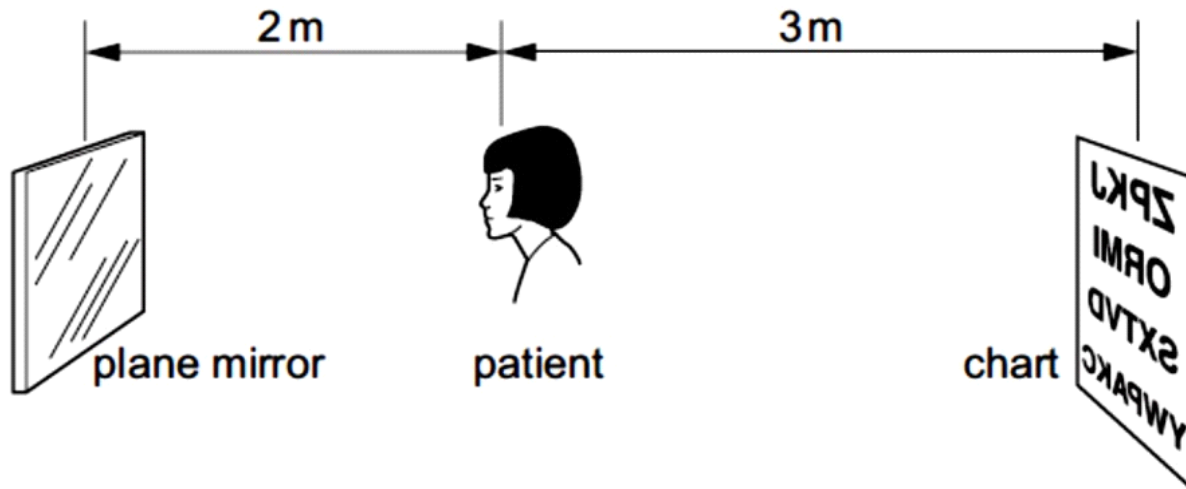

Determine how far away from the patient, the image of the chart is seen.

(2 marks)

.....
7. State Snell's law.

(1 mark)

.....
.....



8. The figure below shows an electric circuit.

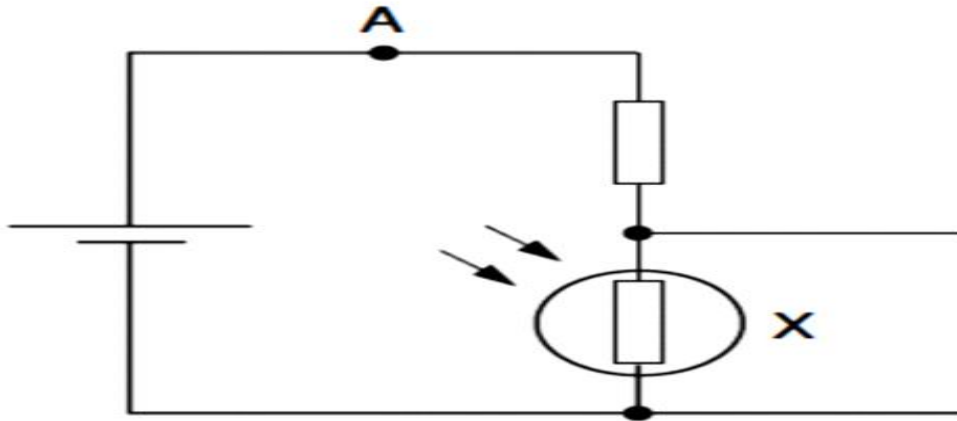

State and explain how the potential difference across X varies as the light shining on it becomes brighter. (2marks)

.....

.....

.....

9. Waves pass from deep water to shallow water and refraction occurs.

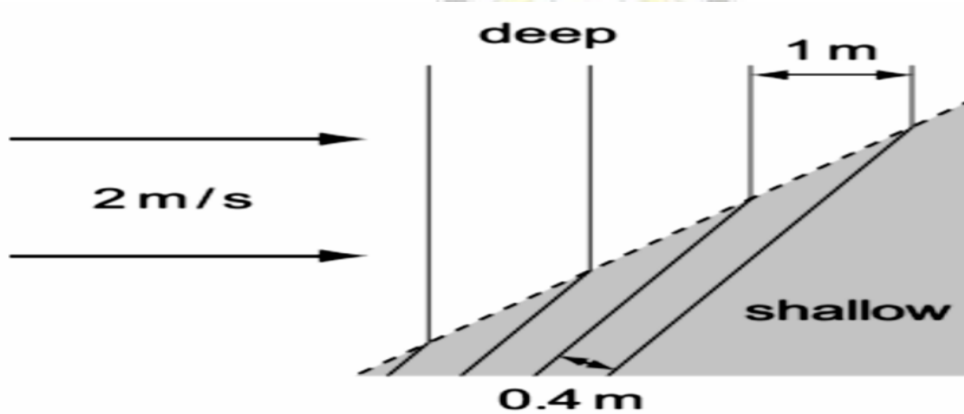

Calculate the speed of the waves in the shallow water (2 marks)

.....

.....

.....



10. The diagram below shows a ray of light striking the plane at 35° as shown below.

State the angle of reflection.

(1 mark)

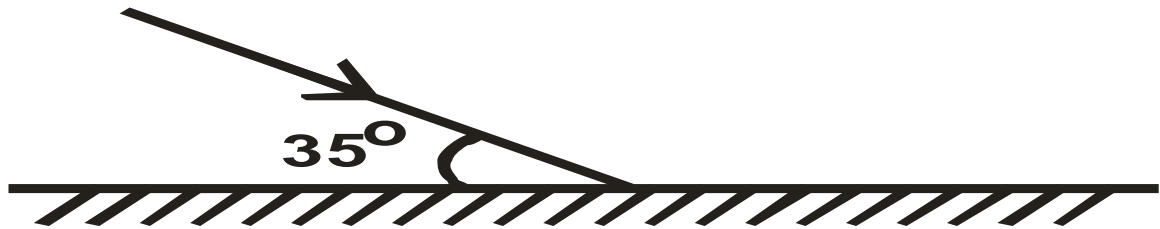

11. The figure below shows an iron bar being magnetized by stroking it with a magnet.

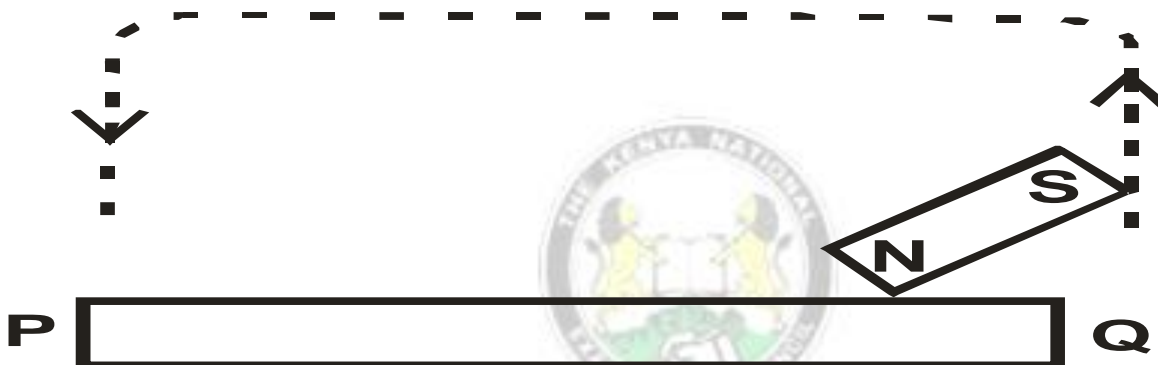

Indicate on the iron bar the polarity of resulting magnet.

(1 mark)

12. An echo sounder of a ship transmits sound waves to the depth of the sea and receives the echo after 2.4 seconds. If the speed of sound in water is 1600ms^{-1} , determine the depth of the sea.

(3 marks)

.....

.....

.....

13. It is observed that when a charged body is brought near the cup of a positively charged electroscope, the divergence of the leaf increases. State the type of charge on the body.

(1mark)

.....

.....



SECTION B (55 marks)

14. (a) The figure below shows a diagram of a Geiger Muller tube connected to a power supply and a pulse counter.

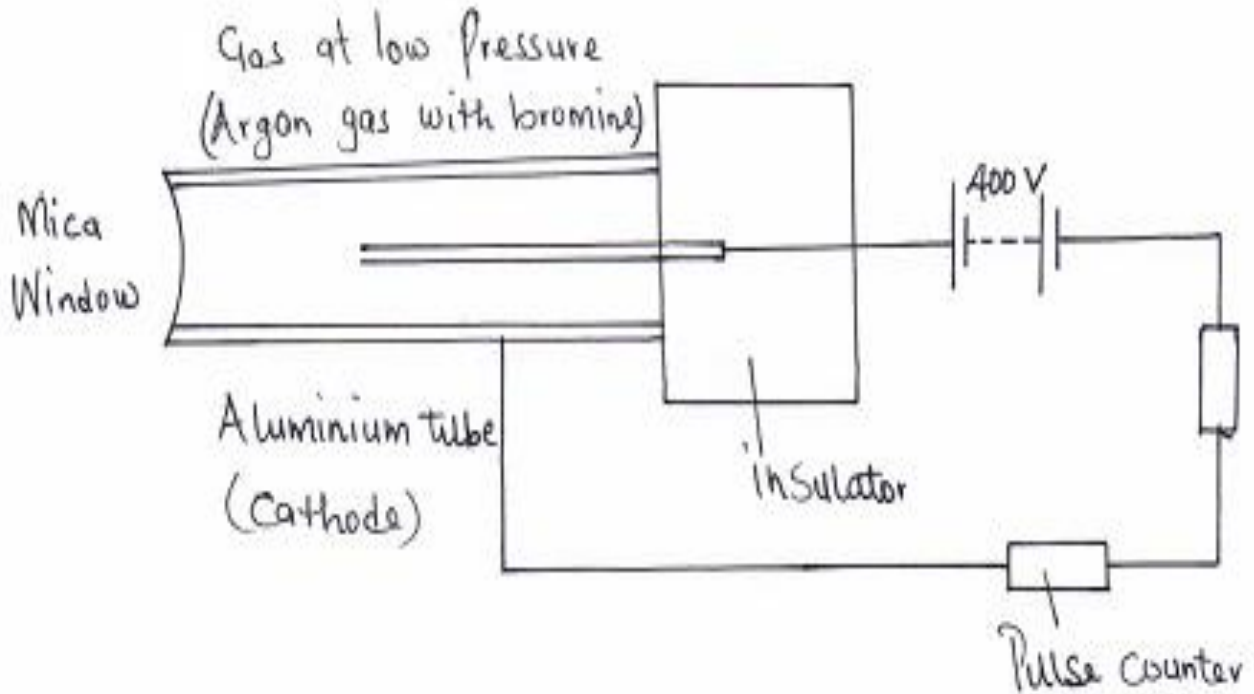

(i) Why should the argon gas be at low pressure? (1mark)

.....
.....

(ii) State the purpose of the bromine gas in the tube. (1mark)

.....
.....

(iii) Suggest one way of increasing the sensitivity of the tube (1mark)

.....
.....

(iv) Find the value of a and b in the following equation. (2marks)



b) The figure below shows a PN junction diode used in a rectifier.

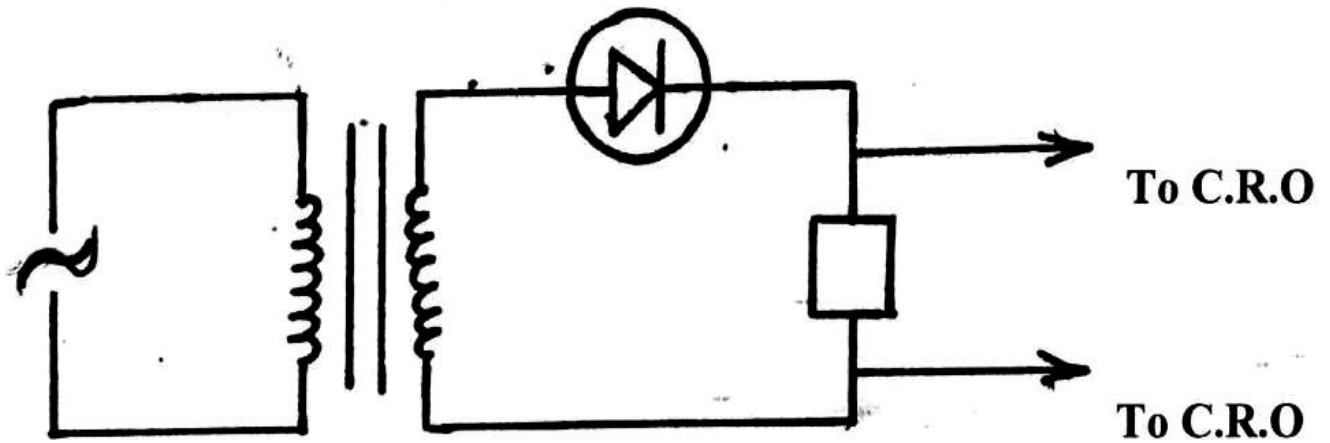

i)) What is an extrinsic semi conductor? (1mark)

.....

ii) What type of rectification is shown? (1mark)

.....
.....

iii) Describe how the rectification is achieved (2marks)

.....
.....
.....

iv) In the space provided below, sketch the output signal displayed on the CRO during the rectification process.

(2marks)



Voltage



15. The figure below shows a cathode ray tube

a) State the function of the

i) Heater

(1mark)

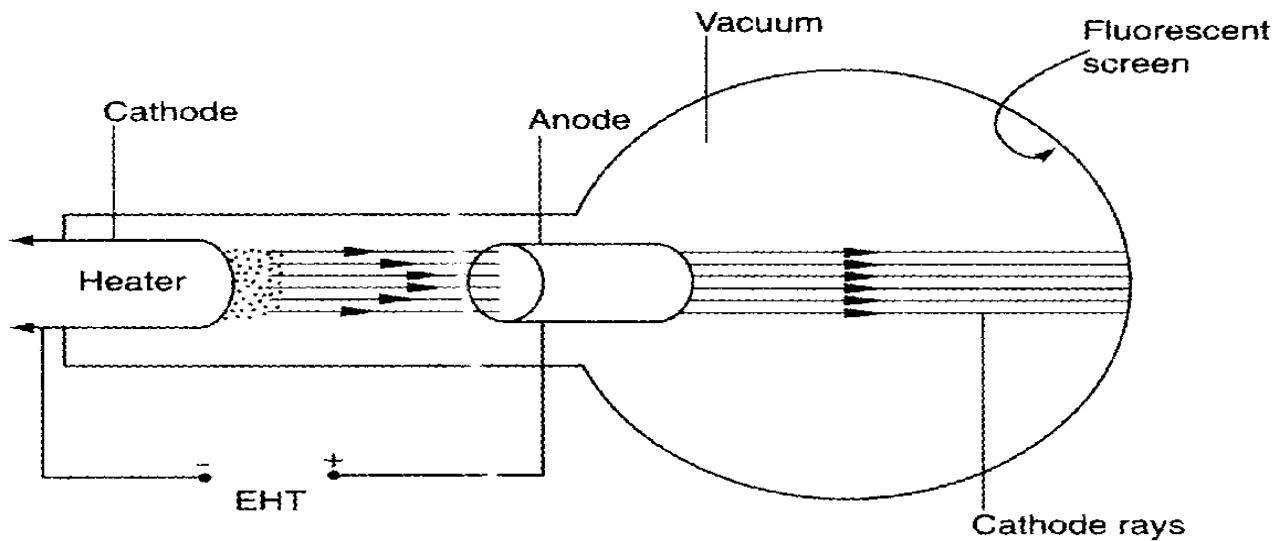

ii) Extra High Tension (E.H.T.)

(1 mark)

.....
.....

b) State how the intensity of the fluorescence on the screen can be increased.

(1 mark)

.....
.....
.....

c) State the effect of having air in the tube instead of a vacuum

(1 mark)

.....
.....

d) State one properties of cathode rays

(1 mark)

.....
.....

e) Distinguish cathode rays and X-rays

(1 mark)

.....
.....
.....
.....

f) Give one advantages of using a C.R.O instead of a voltmeter in measuring voltages

(1 mark)

.....
.....

g) The figure below shows an a.c. voltage. If the Y-gain control reads 10V/cm and the time base reads 5 milliseconds/cm

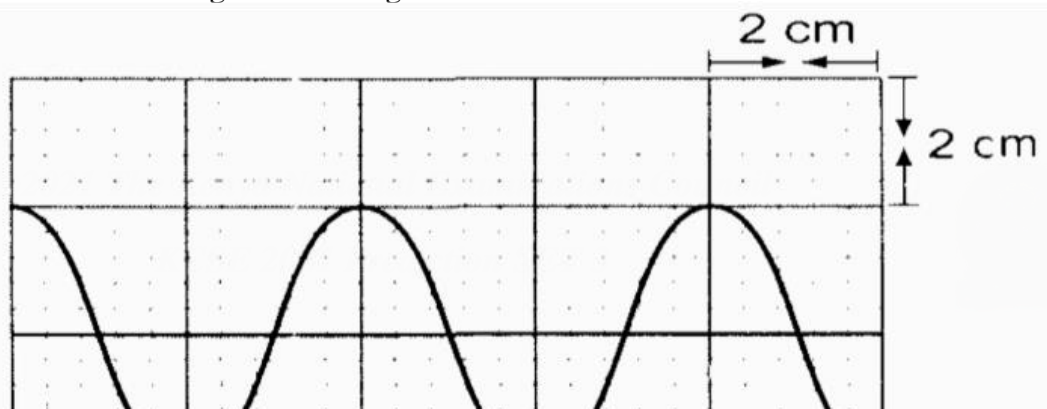

Calculate:

i) The frequency of the alternating voltage **(2 marks)**

.....
.....

ii) Peak to peak voltage of the alternating voltage **(2 marks)**

.....
.....

16 (a)(i) It is observed that when ultra- violet radiation is directed onto a clean zinc plate connected to the cap of a negatively charged leaf electroscope, the leaf falls .Explain this observation **(2 marks)**

.....
.....
.....
.....

(ii) State why this observation does not occur if the electroscope is positively charged **(1 mark)**

.....
.....
.....

(iii) ,Explain why the leaf of the electroscope does not fall when infra- red radiation is directed onto the zinc plate **(1 mark)**



.....
.....
.....
b) State the effect on the electrons emitted by the photoelectric effect when:

(i) The intensity of incident radiation is increased (1 mark)

.....
.....
(ii) The frequency of the incident radiation is increased (1 mark)

c) Light of wavelength $4.3 \times 10^{-7} \text{m}$ is incident on two different metal surfaces, nickel and potassium. (Take speed of light as $3.0 \times 10^8 \text{ms}^{-1}$ and planks constant h as $6.63 \times 10^{-34} \text{Js}$).

(i) Determine the energy of the incident radiation. (3 marks)

(ii) If the work function of nickel is $8.0 \times 10^{-19} \text{J}$ and that of potassium is $3.68 \times 10^{-19} \text{J}$, state with a reason from which of the two metals the given light will eject electrons. (2 marks)

(iii) Determine the velocity of the emitted electrons from the metal surface in b(ii).

(Take the mass of an electron as $9.1 \times 10^{-31} \text{kg}$). (2 marks)



17(a) The figure below shows three resistors as shown.

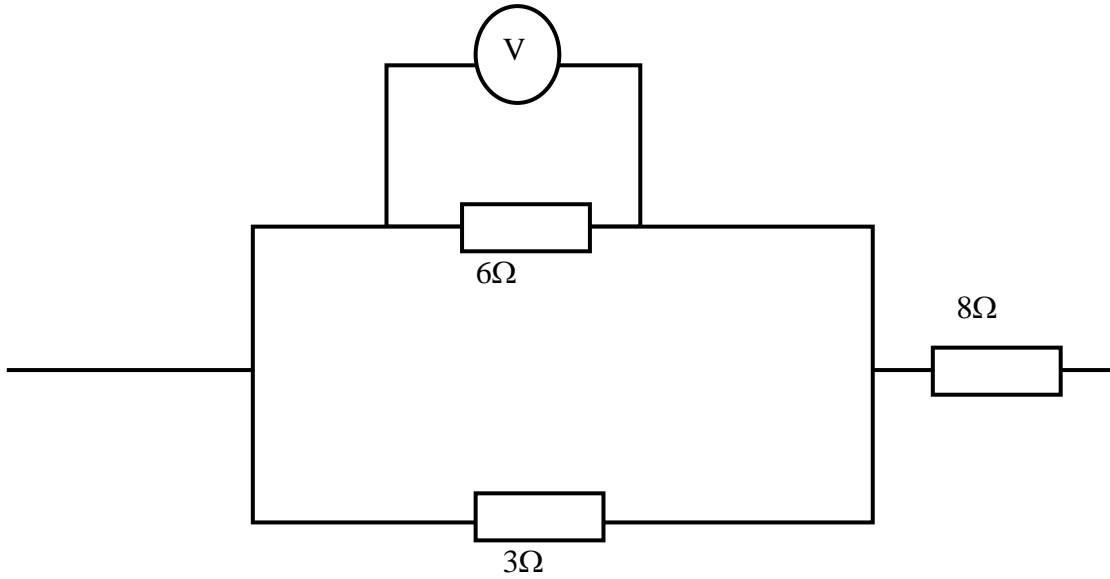

If the voltmeter reads 4V, find the

(i) Effective resistance (3marks)

.....
.....
.....

(ii) Current through the 3Ω resistor (2marks)

.....
.....

(iii) Potential difference across the 8Ω resistor if the voltage total voltage in the circuit is 10V (1 mark)

.....
.....

(c) (i) What is meant by the term “terminal voltage” as used in current electricity? (1mark)

.....
.....

.....(ii) A cell supplies a current of 2.0A when connected to a 0.6Ω resistor and 1.5A when the same cell is connected to a 0.9Ω resistor. Find the e.m.f and the internal resistance of the cell. (3marks)



.....
.....
18(a) Give a reason why a candle flame is blown when a highly charged conductor is brought close to it as shown below. (1mark)

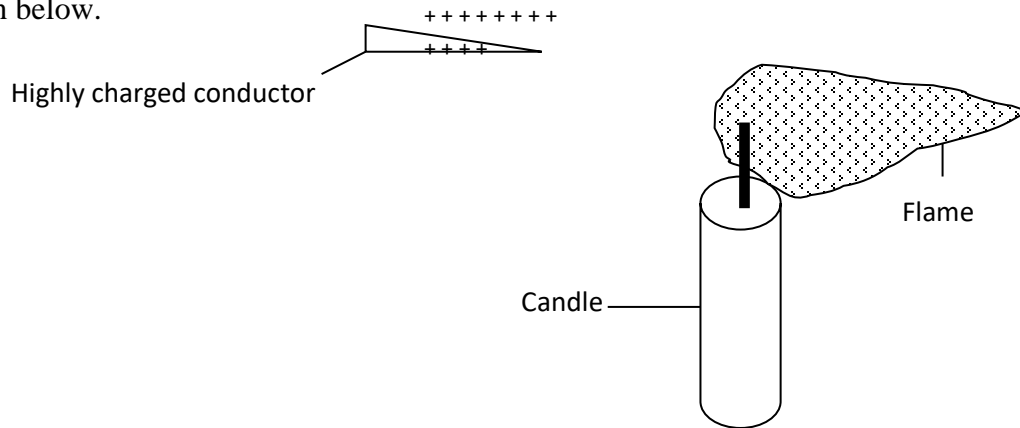

b) State two factors that affect capacitance of a capacitor (2 marks)

.....
.....
.....

c) The figure below shows $1\mu\text{F}$, $2\mu\text{F}$, $4\mu\text{F}$ and $5\mu\text{F}$ capacitors connected to a battery.

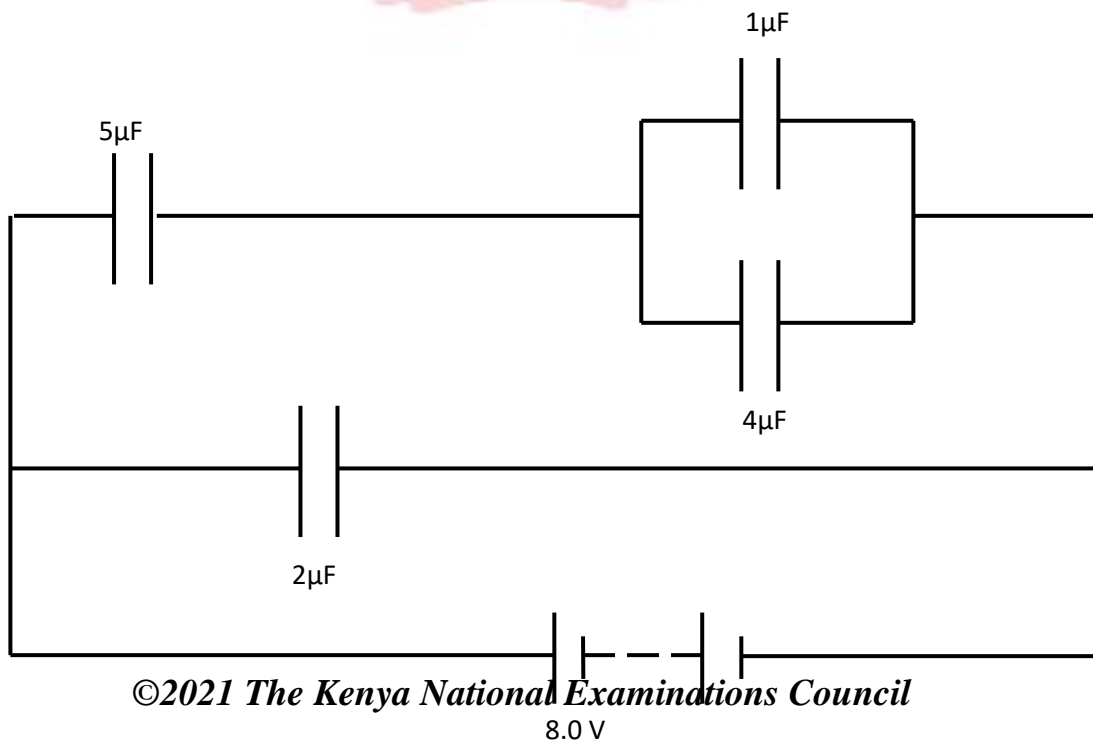

Determine:

i) The total capacitance.

(3marks)

.....
.....
.....



ii) The total energy stored by the capacitors.

(2marks)

.....
.....
.....

iii) Voltage across the $4\mu\text{F}$ capacitor.

(2marks)

.....
.....
.....



THIS IS THE LAST PRINTED PAGE



KCSE 2021 PREDICTION

NAME.....

INDEX NO.....

SCHOOL.....

SIGN.....

DATE.....

PHYSICS

PAPER 3

PRACTICAL

TIME: 2 ½ HOURS

INSTRUCTIONS TO CANDIDATES

- Write **your name** and **index number** in the spaces provided
- Answer **ALL** the questions in the spaces provided in the question paper.
- You are supposed to spend the first 15 minutes of the 2 ½ hours allowed for this paper reading the whole paper carefully before commencing your work.
- Marks are given for clear record of observations made, their suitability, accuracy and the use made of them.
- Candidates are advised to record their observations as soon as they are made.
- **Non-programmable** silent electronic calculators and KNEC mathematical table may be used.
- This paper consists of 7 printed pages. Candidates should check to ensure that all pages are printed as indicated and no questions are missing

FOR EXAMINER'S USE ONLY

QUESTION	MAXIMUM SCORE	CANDIDATES SCORE
1	24	
2	16	
TOTAL	40	

©2021 The Kenya National Examinations Council

KCSE 2021 Prediction SET 3



QUESTION 1 (PART A)

You are provided with the following apparatus:

- A rectangular glass block.
- Four optical pins.
- A soft board.
- A protractor.
- 30cm ruler.
- 2 white plain papers.
- A plane mirror.
- A vernier calipers (to be shared)

PROCEDURE

- Trace the outline of the glass block on the white paper.
- Draw a normal ON, 2cm from point X on side XY.
- Measure an angle (i) 10° from the normal.
- Place back the glass block on the outline and fix a plane mirror vertically along the length of the glass block on the opposite side of XY using a cello tape as shown in the figure below.

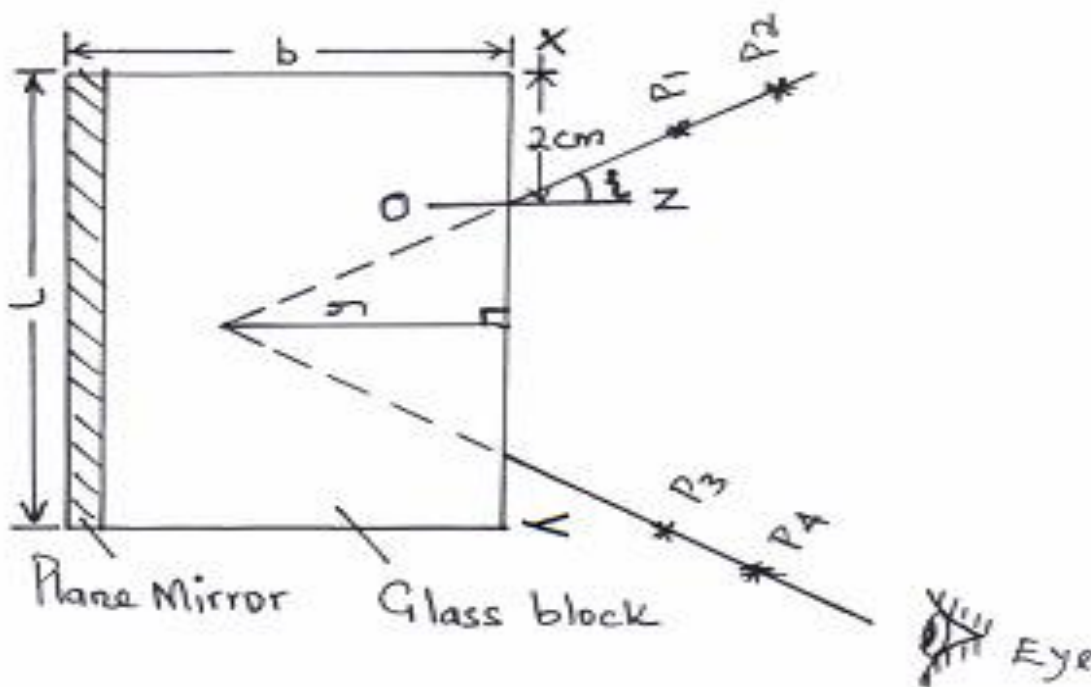

- (e) Fix two pins P_1 and P_2 as shown in the figure.
- (f) By observing image of P_1 and P_2 , locate two pins P_3 and P_4 such that they appear to be in line with images of P_1 and P_2 .
- (g) Remove the pins and the block. Join P_3P_4 and produce the line to meet line P_1P_2 produced
- (h) Measure the perpendicular distance y .
- (i) Repeat the same for angles of 15° , 20° , 25° , 30° , 35° and 40° and record the results in table 2 below.

(NB: The paper work must be submitted together with the question paper).

Table 2

Angle i	10°	15°	20°	25°	30°	35°	40°
$y(\text{cm})$							

(7marks)

- (j) Plot a graph of $y(\text{cm})$ against angle i .

(5marks)

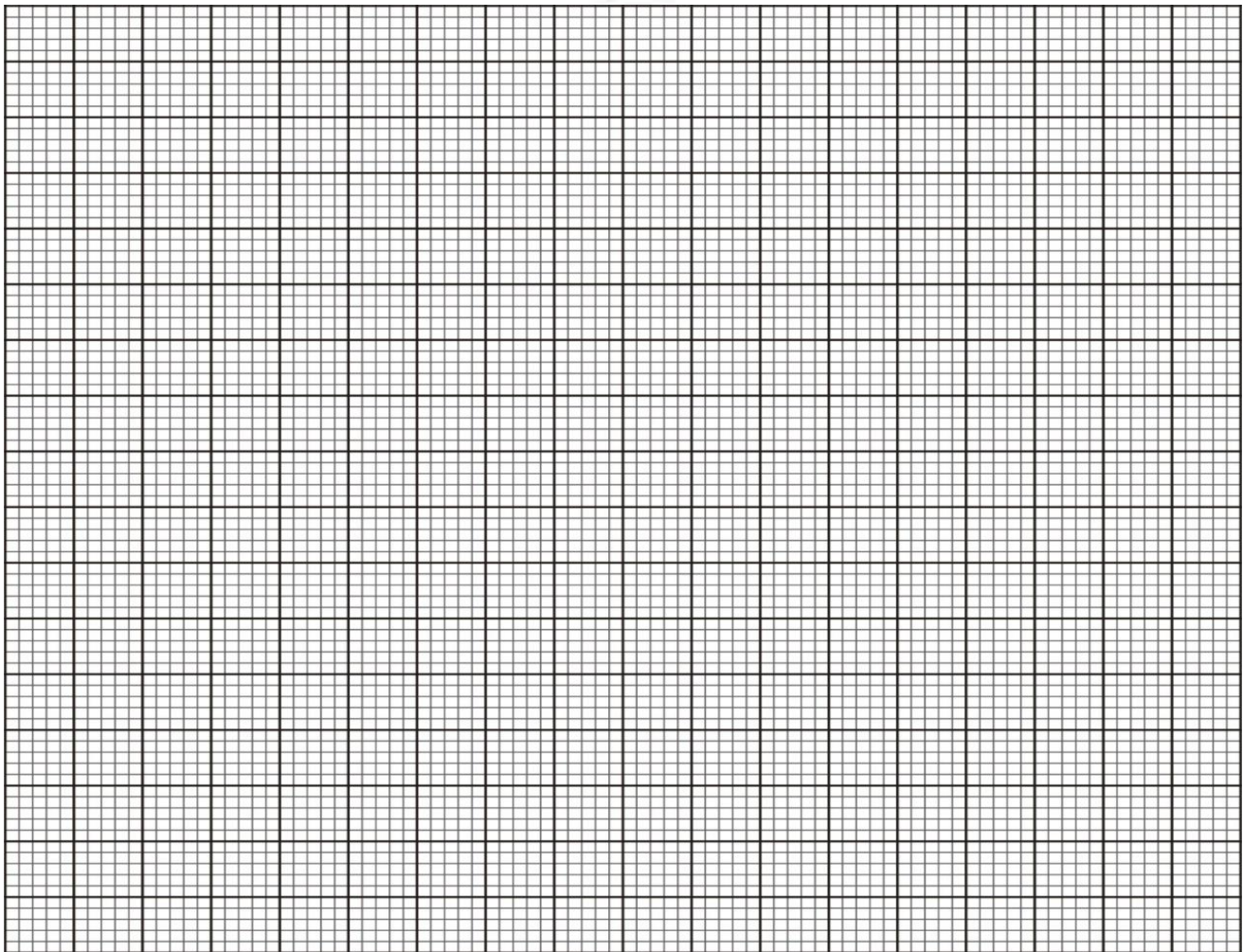

i) Use the graph to determine y_0 the value of y when $i = 0^\circ$

$y_0 = \dots\dots\dots$ cm **(1mark)**

ii) Measure and record the breadth (b) of the glass block

$b = \dots\dots\dots$ Cm **(1mark)**

(ii) Determine the value of η given that

$$\eta = \frac{b}{y_0}$$
 (2marks)

.....
.....
.....
.....
.....
.....
.....
.....
.....



You are provided with the following:-

- A boiling tube.
- Some dry sand.
- A liquid in a measuring cylinder labelled L.
- Half metre rule.
- A vernier calipers (to be shared).
- A weighing machine (to be shared).
- Tissue paper.
- A measuring cylinder.



Proceed as follows:

a) Measure the length of the boiling tube.

$h = \dots\dots\dots$ cm

(1mark)

b) Put a little amount of sand in the boiling tube and place it in the measuring cylinder which is almost filled with liquid L. Add sand, little by little until the tube floats upright as shown in figure below.

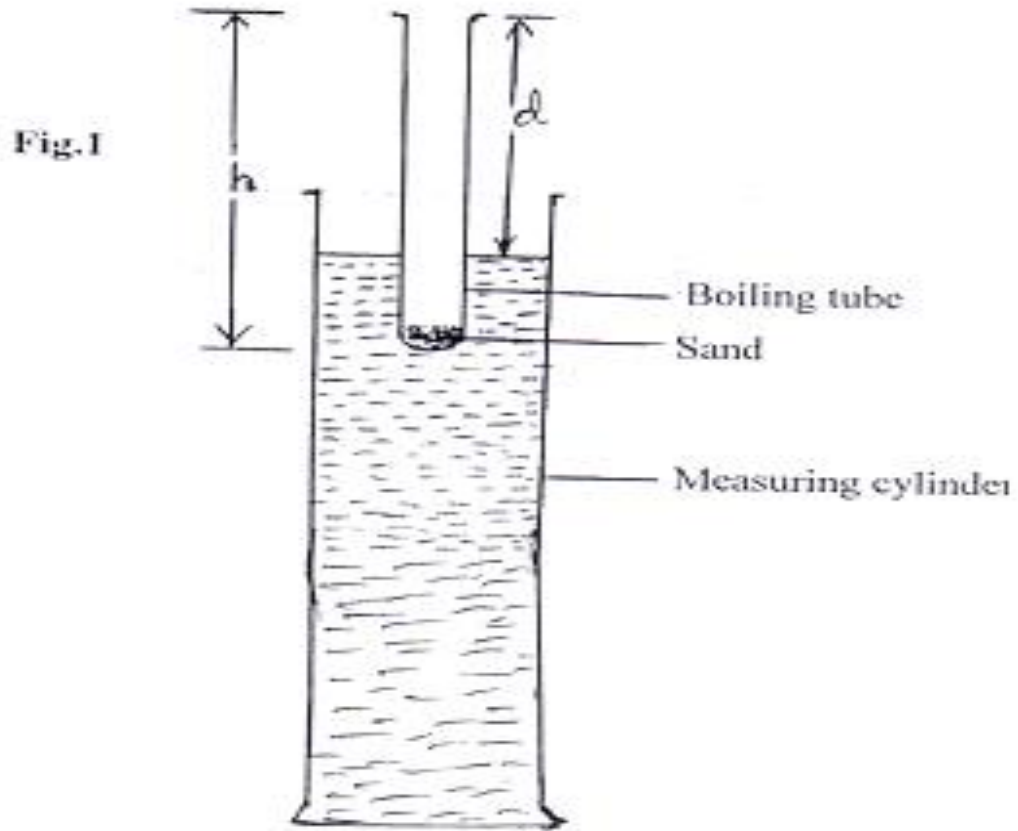

Measure the length, d , of the boiling tube which is above the liquid using half metre rule

$d = \dots\dots\dots$ cm

(1mark)

c).Determine the length, t , of the boiling tube which is immersed in the liquid using half metre rule

$t = \dots\dots\dots$ cm

(1mark)



- d) Remove the boiling tube from the measuring cylinder, wipe it dry (on the outside) and measure its mass, m , including the sand inside.

$m = \dots\dots\dots$ g **(1mark)**

- e) Measure the external diameter, D , of the boiling tube.

$D = \dots\dots\dots$ cm **(1mark)**

- f) Determine the external radius, R .

$R = \dots\dots\dots$ cm **(1mark)**

- g) Using the formula $m = 12\rho\pi R^2$, determine ρ for the liquid. **(2marks)**

.....
.....
.....
.....

Question 2

You are provided with the following:-

- A 250ml glass beaker.
- A Bunsen burner.
- A thermometer.
- A stopwatch.
- A Tripod stand and a wire gauze.
- A measuring cylinder 100ml.
- Water.



Procedure

Set the apparatus as shown in figure below.

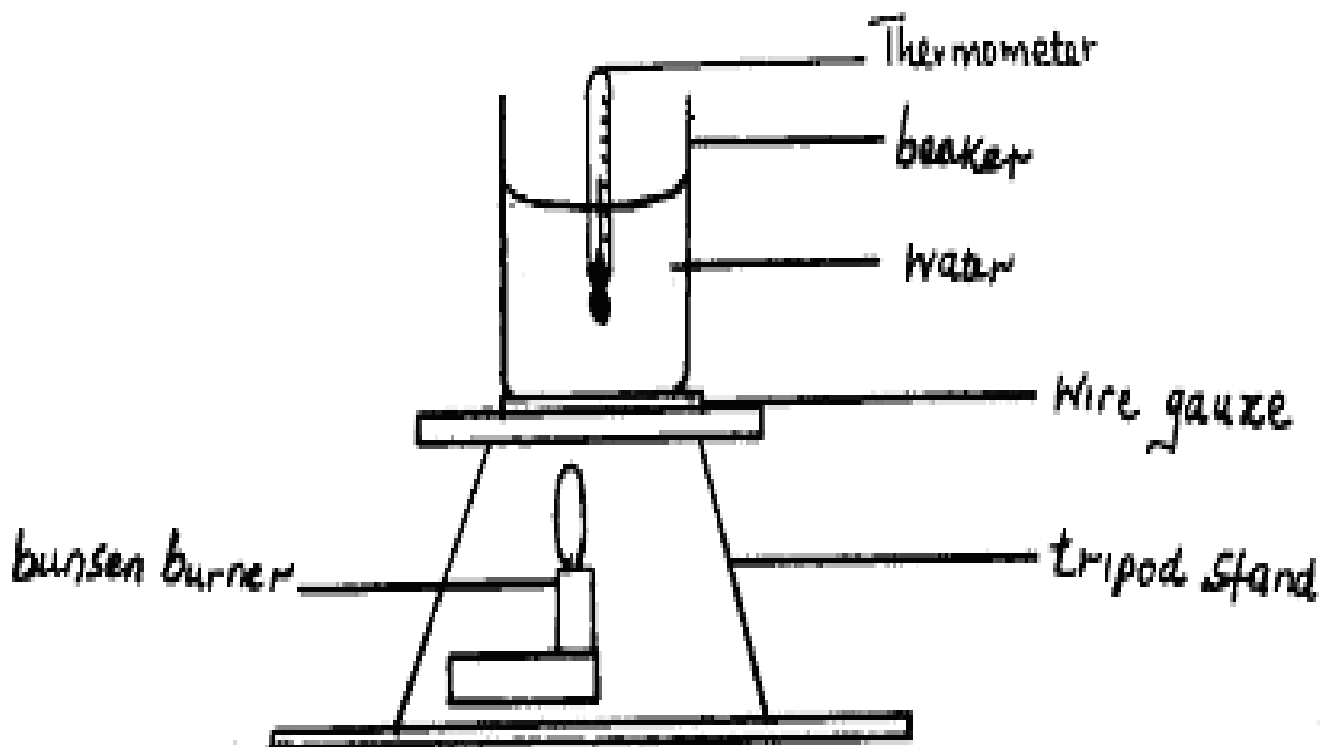

(a) Measure 100cm³ of water and pour it into the beaker. Take the initial temperature of the water.

$T_0 = \dots\dots\dots$ °C. (1mark)

Now heat the water to a temperature of 75°C. Switch off the gas tap and place a thermometer into the beaker and start the stopwatch when the temperature is 65°C. Take the temperature T°C of water every two minutes. Record your results in the table 3 below. (7marks)

Table 3

Time, t(minutes)	2	4	6	8	10	12	14
Temperature, T(°C)							
(T – T ₀) (°C)							
Log (T – T ₀)							



(b) Plot a graph of $\text{Log}(T - T_0)$ against Time (t).

(4marks)

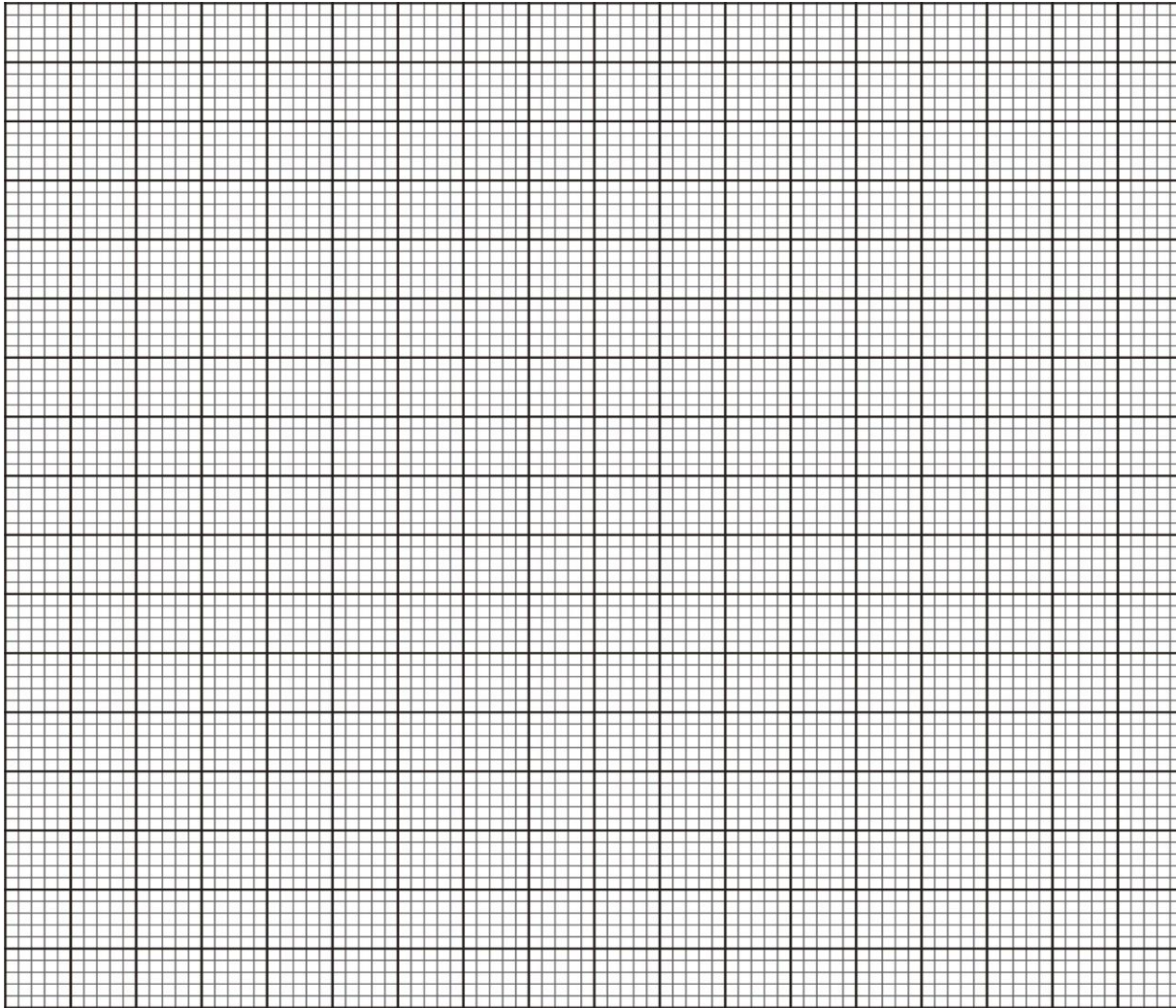

(c) From the graph find the value of Q given that $Q = \log(T - T_0)$ when $t = 0$.

(1mark)

.....
.....

(d) Determine P , where P is the antilog of Q .

(1mark)

.....
.....

(e) Calculate the temperature of the surrounding T_s using expression $P = 65 - T_s$. **(2marks)**

.....
.....



KCSE 2021 PREDICTION

NAME.....

INDEX NO.....

SCHOOL.....

SIGN.....

DATE.....

233/1

CHEMISTRY

PAPER 1

TIME: 1 HOUR

INSTRUCTIONS TO THE CANDIDATES

- Write your *name* and *Admission number* in the spaces provided.
- Answer *all* the questions in the spaces provided.
- *Mathematical tables* and *electronic calculators* may be used
- All working **MUST** be clearly shown where necessary.

For Examiner's Use Only:

Question	Maximum score	Candidate's score
1-25	80 MARKS	



1[a] State Boyle's law **[1mk]**

.....
.....

[b] At 400°C, 850cm³ of a gas exert a pressure of 560mmHg. What volume of the same gas would exert a pressure of 640mmHg at the same temperature? **[3mks]**

.....
.....
.....

2. When burning magnesium is lowered into a gas jar containing nitrogen (I) oxide, it continues to burn forming a white solid

[a] Name the white solid **1mk]**

.....
.....

[b] Write a chemical equation of the reaction that occurred **[1mk]**

.....
.....

3. Carbon {IV} oxide is one of the gases used in fire extinguishers

[a] State any other possible use of carbon {IV} oxide **[1mk]**

.....
.....

[b] Name any two reagents that can be reacted together to generate carbon {IV} oxide **[2mks]**

.....
.....

4. Rusting is a process that causes massive destruction of iron structures

[a] State one condition that accelerates rusting **[1mk]**

.....
.....

[b] State one advantage of rusting **[1mk]**

.....



5. At 60°C , 38 grams of lead(II) nitrate saturate 56cm^3 of water. Determine the solubility of lead(II) nitrate at this temperature [2mks]

.....
.....
.....

6. Explain why molten sodium chloride conducts electricity, but solid sodium chloride does not [2mks]

.....
.....
.....

7. A polymer can be represented as

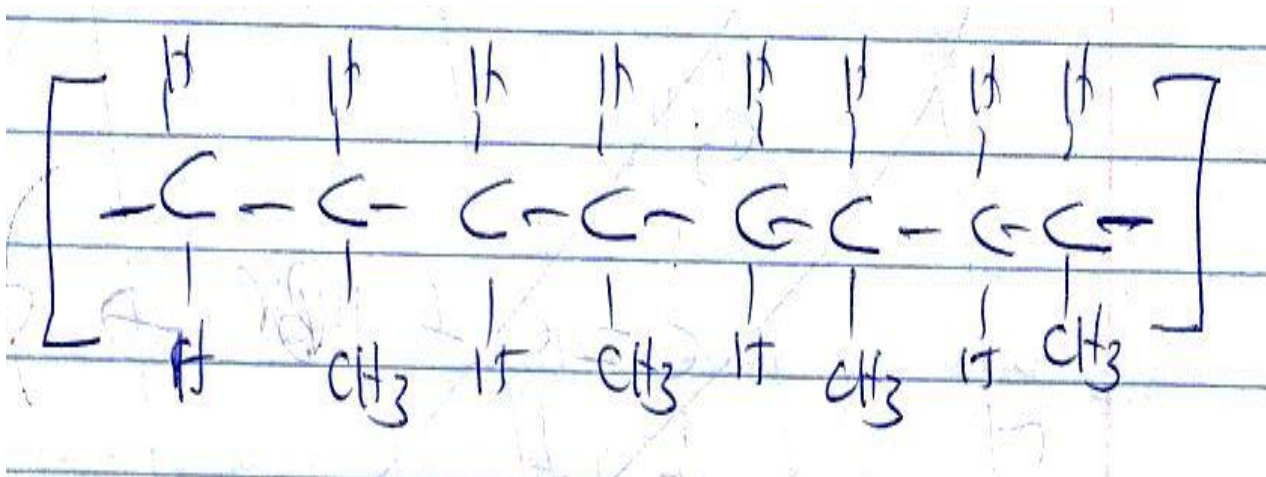

[a] Name and draw the structure of the monomer [2mks]

.....
.....
.....
.....
.....

[b] What type of polymerization occurs in the above case? [1mk]

.....
.....

[c] Given that the molecular mass of the polymer is 25620, how many units of the monomer make the polymer [2mks]

.....



8. A reaction can be represented as;



Given the bond energies of C-H, C=C, C-C, C-Br, and H-Br as 20kJ/mol, 580Kj/mole, 446Kj/mole, 438KJ/mole and 396kJ/mole respectively. Determine the heat of formation of $\text{C}_2\text{H}_5\text{Br}$ [3mks]

9[a] Define the term, dynamic equilibrium [1mks]

[b] A reaction at equilibrium can be represented as



State and explain the observation made when;

[i] NaOH is added to the equilibrium mixture [2mks]

[ii] HCl is added to the equilibrium mixture [2mks]

10. During the electrolysis of dilute copper {II} chloride using carbon electrodes, a current of 1.5A was passed through the solution for 2 hours and 30 minutes

[a] Write the ionic equation of the reaction that occurred at the cathode [1mk]



[b] Given R.A.M of copper = 64 and $1F = 96500C$, calculate the change in mass of the cathode [3mks]

11.[a] Define the term half-life [1mk]

[b] Name two particles likely to be emitted when a radioactive nuclide undergoes radioactivity [2mks]

[c] The half-life of a radioactive nuclide is 3 hours. Given that its initial mass is 288g, determine the remaining mass after 12 hours. [2mks]

12. The reduction potentials of elements M and N are;

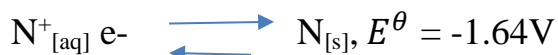

Using the above reduction potentials, predict whether a reaction would occur between

$N^+_{[aq]}$ and $M_{[s]}$ [3mks]



13. An hydrocarbon can be represented as: C_2H_2

[a] Name the hydrocarbon [1mk]

.....
.....

[b] State two reagents that can be reacted together to generate the hydrocarbon [2mks]

.....
.....

[c] Identify the group of hydrocarbons into which C_2H_2 belongs to [1mk]

.....
.....

14.[a] Name two allotropes of sulphur [2mks]

.....
.....

[b] In an experiment to investigate a certain property of sulphur, Maina added few drops of conc HNO_3 to sulphur in a test tube and warmed the mixture

[i] State one observation made [1mk]

.....
.....

[ii] Write a chemical equation of the reaction that occurred [1mk]

.....
.....

15. Chlorine is commonly used in the manufacture of $Ca(OCl)_2$

[i] State one use of the above compound of chlorine [1mk]

.....
.....

[ii] Write a chemical equation leading to the production of $Ca(OCl)_2$ [1mk]

.....
.....



16. A compound can be represented as

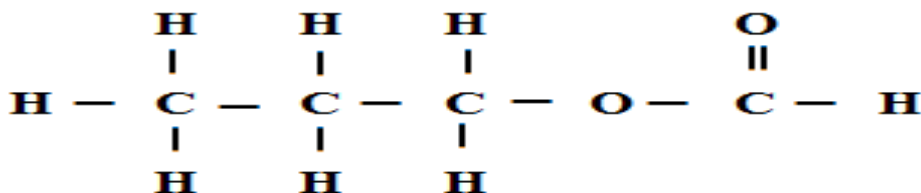

[a] What name is given to the above class of compounds [1mk]

.....
.....

[b] Name two reagents that can be reacted together to generate the above compound [2mks]

.....
.....
.....

[c] State two conditions necessary for the reaction leading to formation of the above compound to occur

[2mks]

.....
.....
.....

17. Using dots and crosses, show bonding in carbon{II} oxide [2mks]

18. When 20g of a compound containing carbon, hydrogen and oxygen was burnt in the air, 29.3g of carbon{IV} oxide and 11.7g of water were produced. Determine its empirical formulae.

{C=12, H=1, O=16}

[3mks]

.....
.....
.....



19. Few drops of hydrochloric acid were added into a test tube containing lead {II} Nitrate solution
{a} State one observation made [1mk]

.....
.....

{b} Write an ionic equation of the reaction that occurred in the test tube [1mk]

.....
.....

20. In the industrial manufacture of Ammonia one of the raw materials is nitrogen gas

{a} Name one other raw material [1mk]

.....
.....

{b} Name two possible sources of the raw material you have named in {a} above [2mks]

.....
.....

{c} Name two substances that can be used as catalyst in this process [2mks]

.....
.....

{d} State one use of ammonia [1mk]

.....
.....

21. Gas X and Y can be collected as shown below

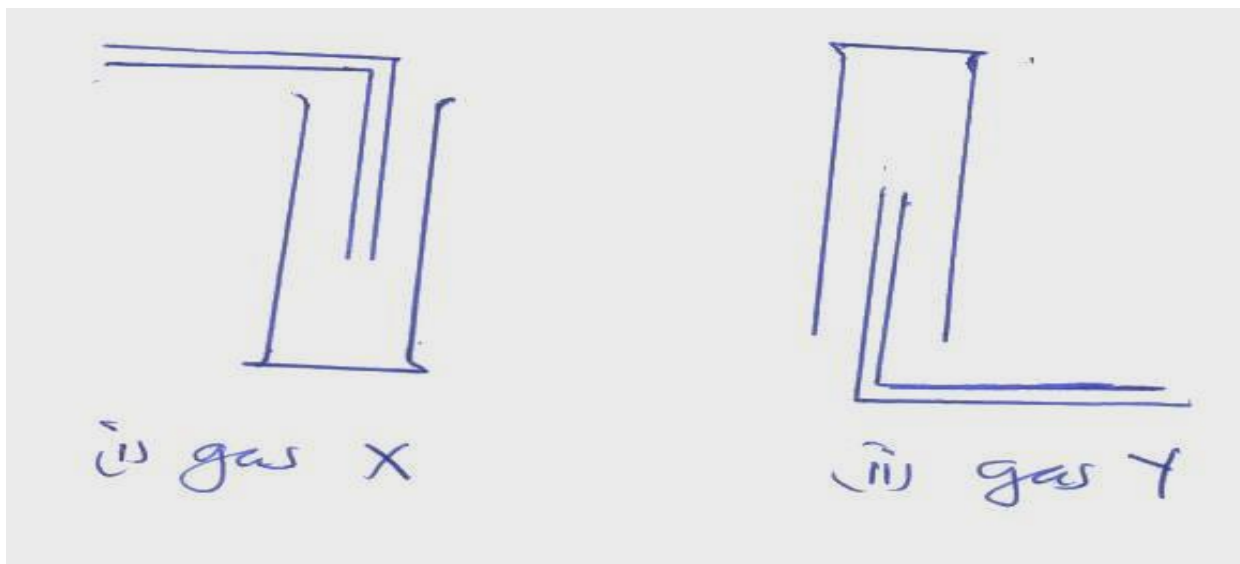

[a] Name the method used to collect gas Y [1mk]

.....
.....

[b] How do densities of gas X and gas Y compare? [1mk]

.....
.....

[c] Give an example of a gas that can be collected using the same method as gas Y [1mk]

.....
.....

22. Element W has two isotopes W – 36 and W-40 which occur in the ratio x:4. Given that R.A.M of W is 37.25, find the value of x [2mks]

.....
.....
.....
.....

23. Describe an experiment that can be used to determine whether a given sample of a liquid is pure [2mks]

.....
.....
.....
.....

24. A given mass of gas T diffuses through a porous plug in 48 seconds while a similar mass of gas R diffuse in 70 seconds. Given that the density of gas T is 0.6g/cm³, find the density of gas R [2mks]

.....
.....
.....

25. The electron configuration of elements A, B, C, D and E are as given below

Element	Electron configuration
A	2, 8, 1
B	2, 8
C	2, 7



For Marking Schemes Contact 0707-550-000 / 0705-525-657

D	2, 8, 6
E	2, 8, 3

{a} Which element has the highest electrical conductivity **[1mk]**

.....

{b} Which letter represents the most reactive metal **[1mk]**

.....

{c} Which letter represents the most reactive non-metal **[1mk]**

.....



©2021 The Kenya National Examinations Council

KCSE 2021 Prediction SET 3



KCSE 2021 PREDICTION

NAME..... INDEX NO.....

SCHOOL..... SIGN.....

DATE.....

Kenya Certificate of Secondary Education (K.C.S.E.)

233/2

CHEMISTRY

PAPER 2

TIME: 2 HOURS

INSTRUCTIONS TO THE CANDIDATES:

- Write your **name** and **admission number** in the spaces provided above
- **Sign** and write the **date** of examination in the spaces provided.
- Answer *all* the questions in the spaces provided.
- All working **must** be clearly shown where necessary.
- Mathematical tables and electronic calculators can be used.

For Examiners Use Only

Question	Maximum score	Candidate's score
1	14	
2	12	
3	11	
4	12	
5	9	
6	12	
7	10	
Total	80	



©2021 The Kenya National Examinations Council

KCSE 2021 Prediction SET 3



1. The grid below shows a section of the periodic table, the letters are not the actual chemical symbol.

K	L			M		N	P	
	Q		R	S		T	V	
W								

a) Name the family into which element P belongs to (1mk)

.....

.....

b) Which two elements forms the most soluble carbonates (2mks)

.....

.....

c) With a reason, identify elements in period 3 with the largest atomic radius (2mks)

.....

.....

d) Write the formula of the compound formed between Q and M (1mk)

.....

.....

e) State two uses of element R and for each use , state property of element R that makes its possible for the use

(i) Use (1mk)

.....

.....

Property (1mk)

.....

.....

(ii) Use (1mk)

.....

.....

Property (1mk)



f) Using dots and cross ,show bonding in the compound formed between R and oxygen (2mks)

g) In terms of structure and bonding explain why the oxides of element Thas relatively low boiling points (2mks)

2.(a) name the following compounds

(3mks)

(i) $\text{CH}_3\text{CH}_2\text{CH}_2\text{COOH}$

(ii)

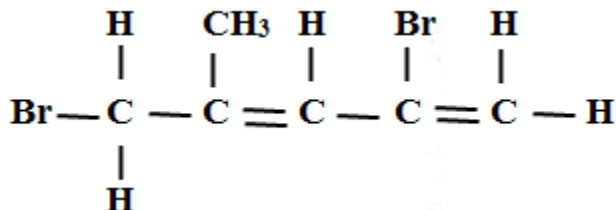

(iii) $\text{CH}_3\text{CH}_2\text{OOCCH}_2\text{CH}_3$

b) Two types of detergents P and Q can be represented as

P: $\text{R} - \text{COONa}$

©2021 The Kenya National Examinations Council

KCSE 2021 Prediction SET 3



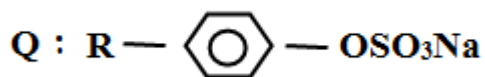

(i) Identify each type of the detergent (2mks)

.....
.....

(ii) Which of the two detergents is the best to use with hard water? Give a reason (2mks)

.....
.....

(iii) State one advantage of detergent P (1mk)

.....
.....

(iv) State one disadvantage of detergent Q (1mk)

.....
.....

(c) An hydrocarbon can be represented as follows

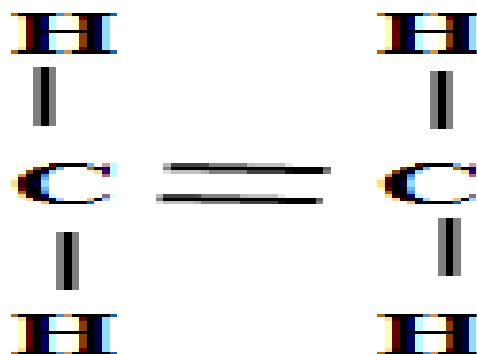

(i) Identify the hydrocarbon (1mk)

.....
.....

(ii) Name two reagents that can react together to generate the hydrocarbon (2mks)

.....
.....

3. (a) Name two apparatuses that can be used for determining mass in a laboratory (2mks)

.....



(b) One of the flames produced by Bunsen burner is the luminous flame

i) Explain why this flame is very bright (1mk)

ii) State two disadvantages of the luminous flame (2mks)

(c) Air is usually one of the substances that is considered as a mixture

(i) Identify the two most abundant component of air (2mks)

(ii) Give two reasons why the air is considered as a mixture (2mks)

(iii) One of the components of air is carbon (iv) oxide. Describe an experiment that can be used to prove the presence of carbon (iv) oxide in the air (2mks)

4.(a) The diagram below shows the process used to obtain Sulphur from underground deposits

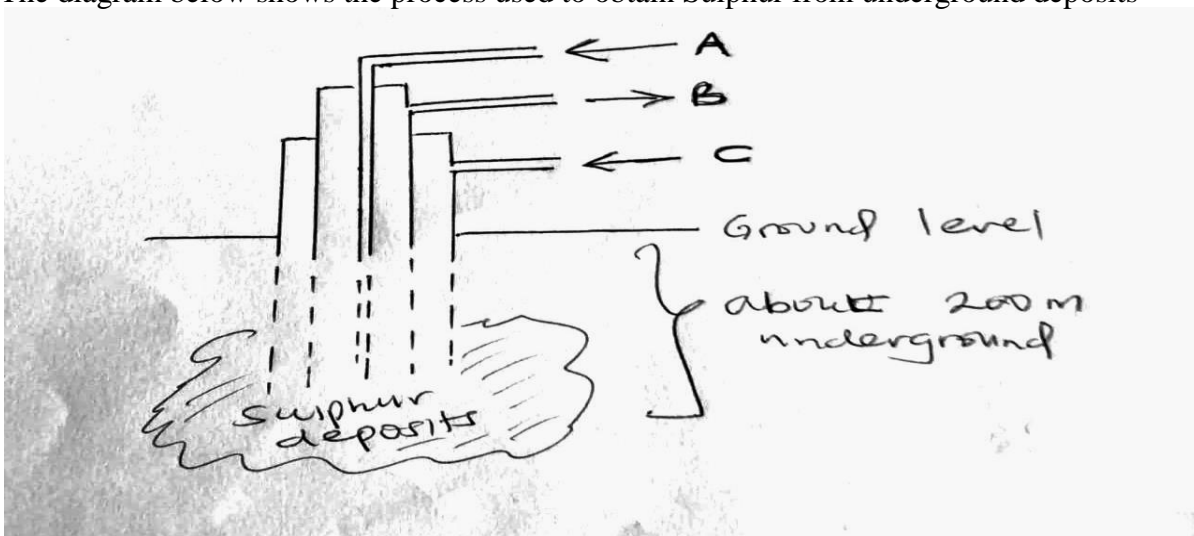

©2021 The Kenya National Examinations Council

KCSE 2021 Prediction SET 3



i) Name the above process used to obtain sulphur from the underground deposits (1mk)

.....
.....

ii) Name the substance passed through pipe

A (1mk)

.....
B (1mk)

iii) State two properties of Sulphur that makes it possible to extract using the above process (2mks)

.....
.....
.....

b) The diagram below shows the contact process used in the manufacture of concentrated sulphuric(vi) acid

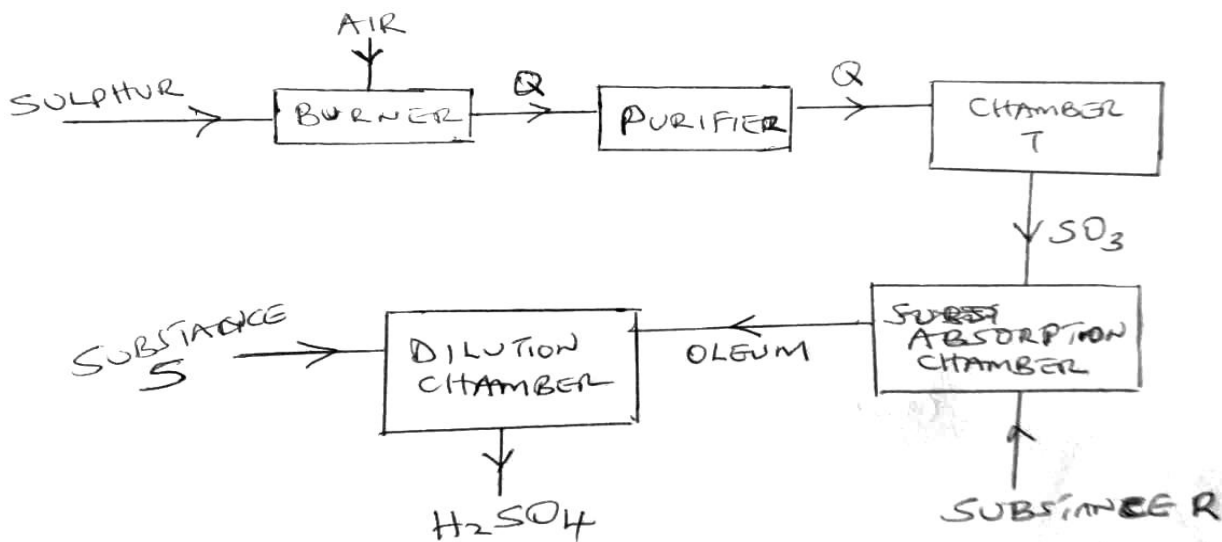

i) Identify the following:

a) Substance Q formed in the burner (1mk)

.....



b) Chamber T (1mk)

.....

c) Substance R (1mk)

.....

d) Substance S (1mk)

.....

ii) Write the chemical equation occurring in the dilution chamber (1mk)

.....

.....

iii) Why is it necessary to pass substance Q through a purifier (1mk)

.....

.....

iv) State one use of sulphuric (VI) acid (1mk)

.....

5.(a) Calamine is one of the ores from which zinc can be extracted from

(i) Name any other ore from which zinc can be extracted from (1mk)

.....

.....

(ii) The calamine is usually decomposed by heating to obtain substance M as shown below



Identify substance M (1mk)

.....
.....

(iii) Identify two methods that can be used to obtain zinc from substance M (2mks)

.....
.....
.....

(b) During the extraction of zinc, name two gases likely to be emitted into the air and that are likely to cause pollution (2mk)

.....
.....
.....

(c) State one likely pollution effect of each of the gases you have mentioned in (a) above (2mks)

.....
.....
.....

(d) State one possible use of zinc metal (1mk)

.....
.....
.....

6.(a) Define the term electrolysis (1mk)

.....
.....
.....

(b) State two functions of a salt bridge during electrolysis (2mks)

.....
.....
.....

(c) The reduction potential of elements K, L, M, and P are as given below.



©2021 The Kenya National Examinations Council

KCSE 2021 Prediction SET 3





- (i) Which letter represents the, strongest reducing agent? give a reason (2mks)

.....
.....

- (ii) Which two letters represent elements whose half cells would form an electrochemical cell with the largest e.m.f? (1mk)

.....
.....

- (iii) Calculate the e.m.f of the cell formed in (ii) above (2mks)

.....
.....
.....
.....

(d) During the electrolysis of a molten chloride of metal Q, a current of 0.25A was passed through the molten chloride for 2 hours and 10 minutes. Given that 0.9 grams of metal Q were deposited at the cathode.

- (i) Calculate the quantity of electricity passed (1mk)

.....
.....
.....

- (ii) Charge carried by the ions of metal Q given that R.A.M of metal Q is 84 (3mks)

.....
.....
.....
.....



.....
7 (a) starting with magnesium oxide, describe how you can obtain a dry sample of magnesium Carbonate (3mks)

.....
.....
.....
.....
.....
.....
.....
.....
.....
.....
.....

(b) (i) Give one example of an acid salt (1mk)

.....

(ii) When sodium nitrate was heated a solid A and gas B were produced identify solid A and gas B (2mks)

.....
.....

(iii) State two uses of gas B produced in (ii) above (2mks)

.....
.....

(c) State two factors that should be considered when choosing a fuel (2mks)

.....
.....
.....



KCSE 2021 PREDICTION

NAME.....

INDEX NO.....

SCHOOL.....

SIGN.....

DATE.....

Kenya Certificate of Secondary Education (K.C.S.E.)

233/3

CHEMISTRY

PAPER 3

TIME: 2 ¼ HOURS

Practical

INSTRUCTIONS TO THE CANDIDATES:-

- Write your name and index number in the spaces provided
- Sign and write the date of examination in the spaces provided
- Answer all the questions in the spaces provided.
- Mathematical tables and electronic calculators may be used.
- All working **MUST** be clearly shown where necessary.
- Use the first 15 minutes of the 2 ¼ hours to ascertain you have all the chemicals and apparatus that you may need.

For Examiners use Only

QUESTION	MAXIMUM SCORE	CANDIDATES SCORE
1	15	
2	11	
3	14	
TOTAL	40	

©2021 The Kenya National Examinations Council

KCSE 2021 Prediction SET 3



QUESTION 1

- You are provided with solution **K** and **L**
- Solution **K** is 1M H_2SO_4
- Solution **L** contains 8.7g of the hydroxide of metal **M** {with formulae MOH } in 600cm^3 of the solution
- You are required to carry out the experiment to determine;
 - i. Concentration of solution **L**
 - ii. R.A.M of metal **M**

Procedure

1. Measure 75cm^3 of solution **K** and put into a clean 250cm^3 volumetric flask and add distilled water up to the mark
-label this solution **W**
2. Fill a clean burette with solution **W**
3. Pipette 25cm^3 of solution **L** into a clean conical flask and add 2 drops of phenolphthalein indicator
4. Titrate the solution **W** in the burette against solution **L** in the conical flask and record the results in the table below
5. Repeat {3} and {4} above as you fill the table below.

TABLE 1

	I	II	III
Final burette reading $\{\text{cm}^3\}$			
Initial burette reading $\{\text{cm}^3\}$			
Volume of solution W used $\{\text{cm}^3\}$			

[4mks]

{a} Calculate the;

{i} Average volume of solution **W** used

[1mk]

.....
.....
.....

{ii} Concentration of solution **W**

[1mk]

.....



.....
.....
.....
{iii} Number of moles of solution W that reacted with each 25cm³ portion of solution L {2mks}

.....
.....
.....
{b} Calculate the;

{i} Number of moles of the metal hydroxide {MOH} in solution L that reacted with each portion of solution W [2mks]

.....
.....
.....
{ii} Concentration of solution L [1mk]

.....
.....
.....
{iii} Number of moles of the metal hydroxide [MOH] in 600cm³ of solution L [2mks]

.....
.....
.....
{iv} R.A.M of metal M [2mks]
[O=16, H=1]



QUESTION 2

You are provided with solution N and P

- Solution N is 2M HCl
- Solution P is 0.16M sodium thiosulphate
- You are required to carry out the experiment below to determine how concentration affects the rate of reaction between HCl and sodium thiosulphate solutions

PROCEDURE

1. Fill a clean burette with solution P.

Measure 25cm³ of the solution P from the burette into a clean 100cm³ glass beaker and place on a white piece of paper with a cross[x] marked on it

2. Add 10cm³ of solution N into it and immediately start a stop watch and note the time taken for the cross beneath the mixture to become invisible
3. Clean the 100cm³ beaker and measure into it 20cm³ of solution P from the burette, and add 5cm³ of distilled water into the solution
4. Repeat step [2] above and note the time taken for the cross to become invisible
5. Repeat the experiment using volumes indicated on the table below and as you record the result

TABLE 2

Expt	1	2	3	4	5
Volume of solution p(cm ³)	25	20	15	10	5
Volume of water added to solution p{cm ³ }	0	5	10	15	20
Volume of solution N	10	10	10	10	10
Time taken for the cross to become invisible [in seconds]					
$\frac{1}{t} \text{ S}^{-1}$					

(4mks)



For Marking Schemes Contact 0707-550-000 / 0705-525-657

[a] plot a graph of $\frac{1}{t}$ against volume of solution P on the grid provided

[3mk]

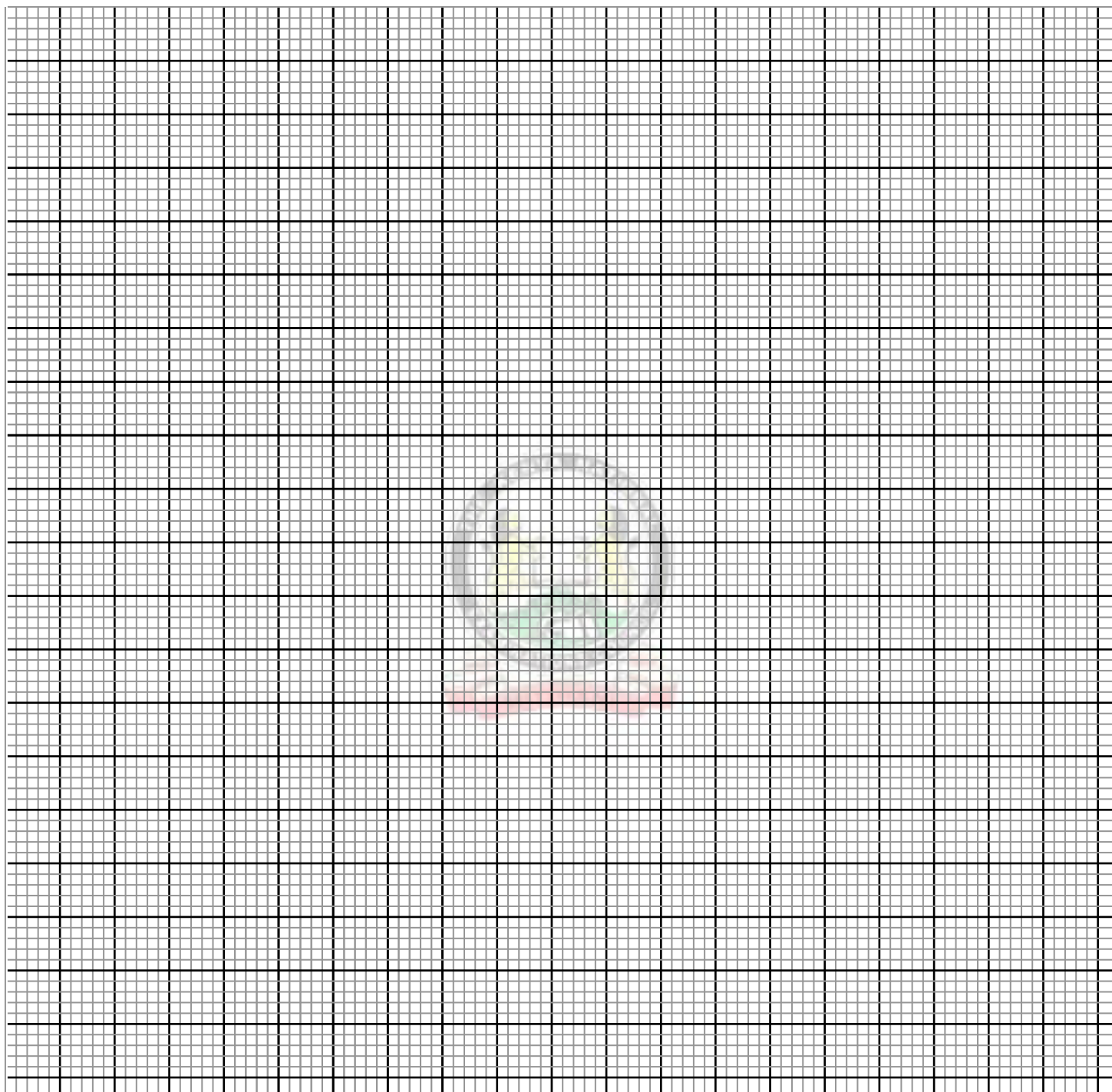

©2021 *The Kenya National Examinations Council*

KCSE 2021 Prediction SET 3



{b} From the graph

{i} Determine the time taken for the cross to become invisible when 12.5cm^3 of solution P is used
[2mks]

{ii} Explain the effect of concentration on the rate of reaction between HCl and sodium thiosulphate solution
[2mks]

QUESTION 3

- You are provided with solids Q and R
- You are required to carry out the tests below as you record your observations and inferences

(i) **SOLID Q**

-Add about 5cm^3 of distilled water to solid Q, shake the mixture thoroughly for a while and then filter it

NOTE: Retain both the filtrate and the residue for the tests below

	TEST	OBSERVATIONS	INFERENCES
(a){i}	Divide the filtrate into 4 portion -To the first portion, add 4 drops of NaOH	$\left(\frac{1}{2} \text{mark}\right)$	(1mark)
{ii}	Scoop the 2 nd portion on a metallic spatula and ignite on a non-luminous flame		



		$\left(\frac{1}{2} \text{ mark}\right)$	$\left(\frac{1}{2} \text{ mark}\right)$
{iii}	To the 3 rd portion, add 2 drops of $\text{Pb}\{\text{NO}_3\}_{\text{aq}}$	$\left(\frac{1}{2} \text{ mark}\right)$	(1mark)
{iv}	To the 4 th portion ,add acidified KmnO_4	 $\left(\frac{1}{2} \text{ mark}\right)$	$\left(\frac{1}{2} \text{ mark}\right)$
b{i}	Put the residue in a test tube and add about 2cm^3 of HNO_3	$\left(\frac{1}{2} \text{ mark}\right)$	(1mark)
{ii}	To the mixture in b{i} above, add 2 drops of KI solution	$\left(\frac{1}{2} \text{ mark}\right)$	$\left(\frac{1}{2} \text{ mark}\right)$



{ii}SOLID R

	TEST	OBSERVATIONS	INFERENCES
(a)	Scoop a portion of solid R on a Metallic spatula and burn on a Non-luminous flame		
		(1mark)	(1mark)
(b){i}	Put the remaining portion of solid R into a clean test tube and add about 3cm ³ of distilled water, shake and divide into 2 portions		
		(1mark)	($\frac{1}{2}$ mark)
{ii}	To the 1 st portion, add 2 drops of acidified KMnO ₄ and warm		
		($\frac{1}{2}$ mark)	(1mark)
{iii}	To the 2 nd portion add NaCO ₃		
		($\frac{1}{2}$ mark)	(1mark)



KCSE 2021 PREDICTION

NAME.....

INDEX NO.....

SCHOOL.....

SIGN.....

DATE.....

Kenya Certificate of Secondary Education (K.C.S.E.)

231/1

BIOLOGY

PAPER 1

THEORY

TIME: 2 HOURS

INSTRUCTIONS TO CANDIDATES:

- Write your **name** and your **admission number** in the spaces provided above.
- **Sign** and **write** the date of the examination in the spaces provided above.
- Answer **all** the questions in the spaces provided.

For Examiner's Use Only:

QUESTIONS	MAXIMUM SCORE	CADNIDATE'S SCORE
1 – 26	80	



©2021 The Kenya National Examinations Council

KCSE 2021 Prediction SET 3



1. Name the cell organelles that would be abundant in:

a) White blood cells destroying pathogens **1mk**

.....
.....

b) Palisade mesophyll cells **1mk**

.....
.....

c) Skeletal muscle cells **1mk**

.....
.....

2. The following graph represents a growth pattern observed in a group of animals

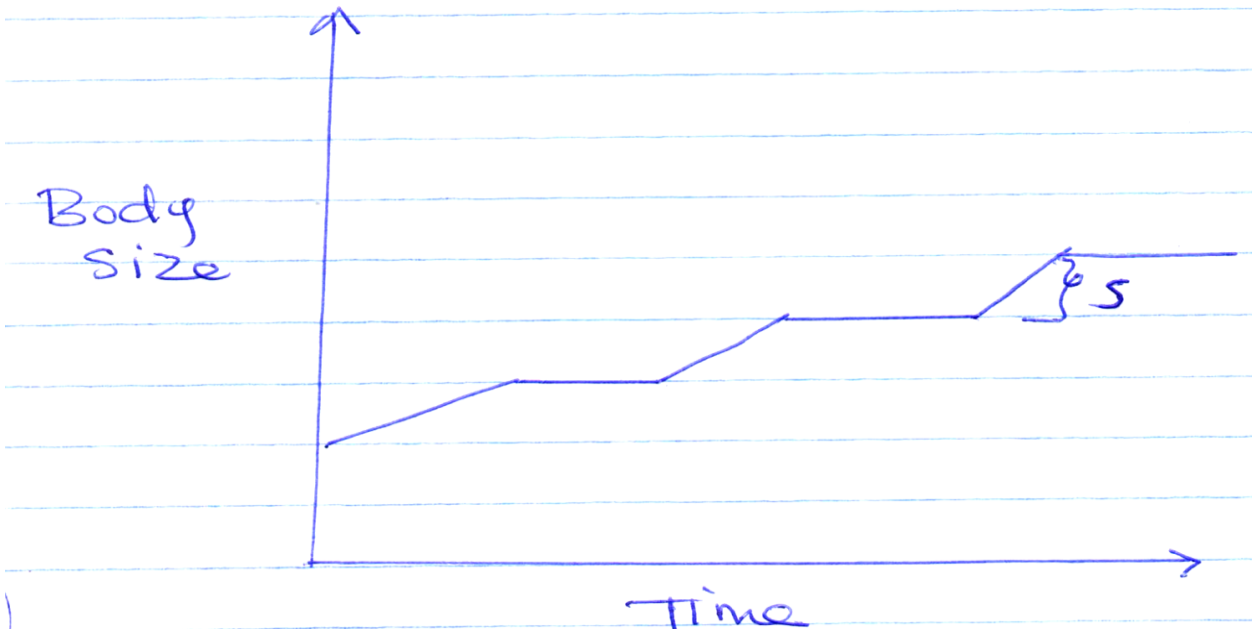

a) Name the type of growth shown above **(1mk)**

.....
.....

b) Name the phylum of animals whose members display the growth pattern named in (a) above **(1mk)**

.....
.....

c) Identify the process which leads to increase in body size at the part marked S **(1mk)**

.....
.....



3. (a) When observing a specimen through a light microscope, a student noted that the field of view was dark. Name 2 parts of the microscope that the student should adjust to make the field of view clear **(2mks)**

.....

.....

.....

- b) A specimen was magnified 1000 times by a light microscope whose eye piece lens magnification is x10. Calculate magnification of objective lens **(2mks)**

.....

.....

.....

4. The flow diagram below represents a process of photosynthesis. Study diagram and answer the questions that follow

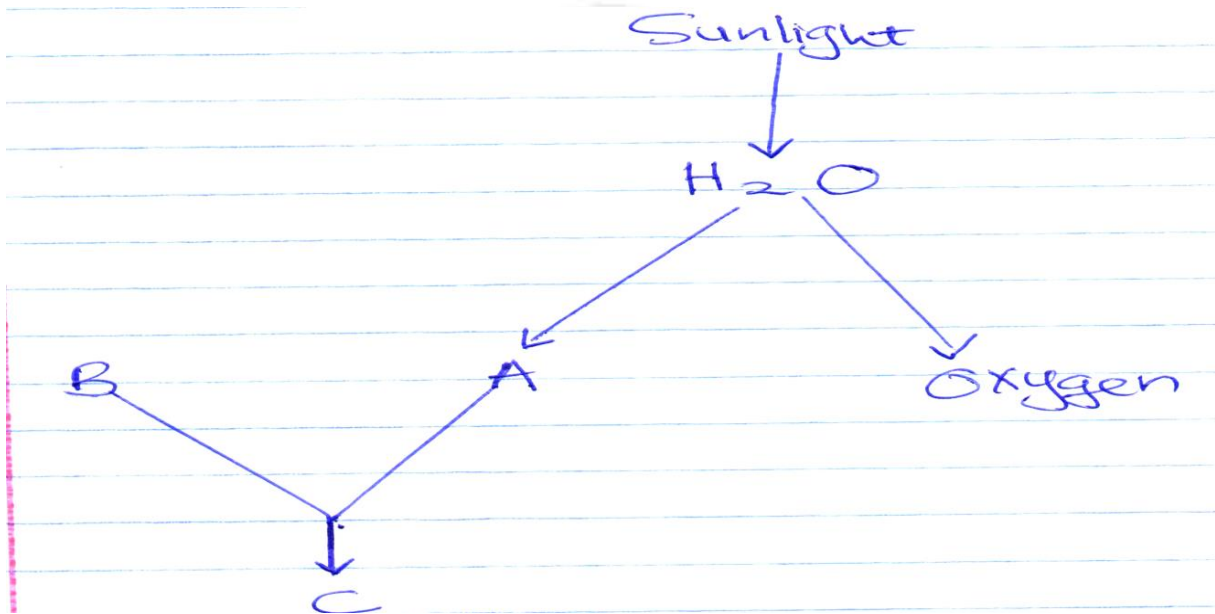

- (a) Name the substances labeled **(3mks)**

A

B

C

- (b) Write an equation to show the process illustrated above **(1mk)**

.....



5. Name the parts of the body of a mammal where each of the following types of joints are found (3mks)

(i) Fixed joints

.....
.....

(ii) Gliding joint

.....
.....

(ii) Huge joint

.....
.....

6. The following is a diagrammatic representation of protein synthesis. Study and answer the questions that follow.

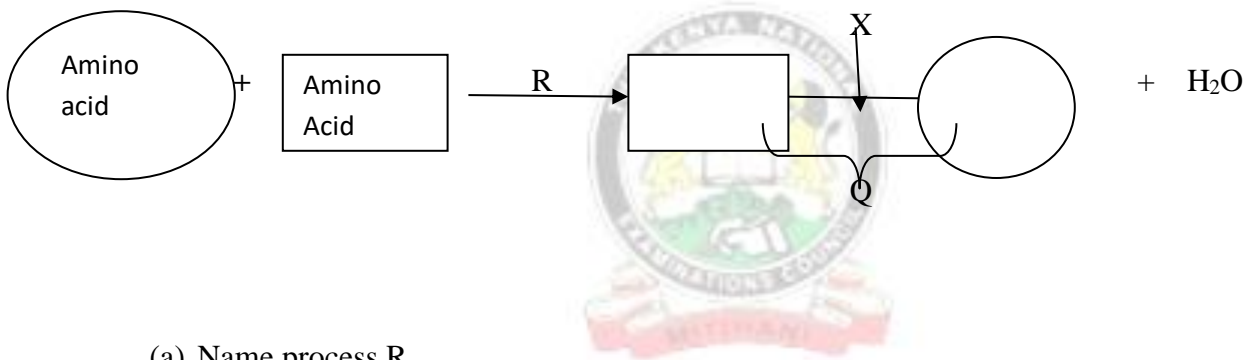

(a) Name process R (1mk)

.....
(b) Where in the cell does R take place? (1mk)

.....
(c) Name

(i) Product Q (1mk)

.....
(ii) Part X (1mk)

.....
7. (a) Name an element which is present in proteins but is not in carbohydrates (1mk)

.....
.....



(b) State three functions of proteins in the human body (3mks)

.....
.....
.....

8. State the functions of the following cell structures during cell division (2mks)

(i) Centriole

.....
.....

(ii) Centromere

.....
.....

9. In a blood test, a few drops of anti- serum were added to two samples of blood. It was observed that agglutination occurred. What were the possible blood groups of the two blood samples (2mks)

.....
.....

10. Name the division of the kingdom Plantae with the following spores producing bodies (2mks)

(i) Sori

.....
.....

(ii) Sporangium

.....
.....

11. (a) What structure in a mammal is represented by the following? 3mks

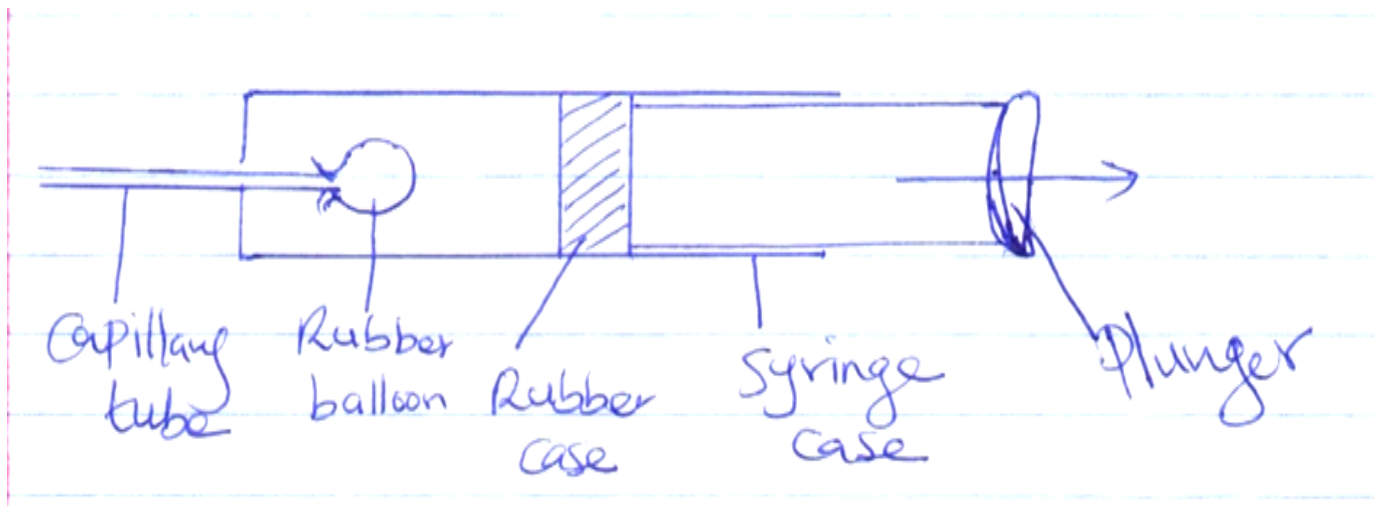

(i) The rubber balloon

(ii) The syringe case

(iii) The plunger

b) Describe what happens if the rubber plug is pulled in the direction shown by the arrow **(1mk)**

12 (a) Define the term alleles **(1mk)**

(b) Explain why the body temperatures of a healthy human beings must rise up to 39°C on a humid day **(2mks)**

(c) In an experiment, a piece of brain was removed from a rat. It was found that the rat had large fluctuation of body temperatures. Suggest the part of the brain that had been removed (1mk)

13. Name the causative agent of the following diseases in humans **(2mks)**

(a) Ameobic dysentery

(b) Candidiasis

14 (a) Define the term immunity **(1mk)**

(b) Distinguish between natural immunity and acquired immunity **(2mks)**



(c) Identify one immunizable disease in Kenya

(1mk)

15. The chart below shows a feeding relationship in a certain ecosystem

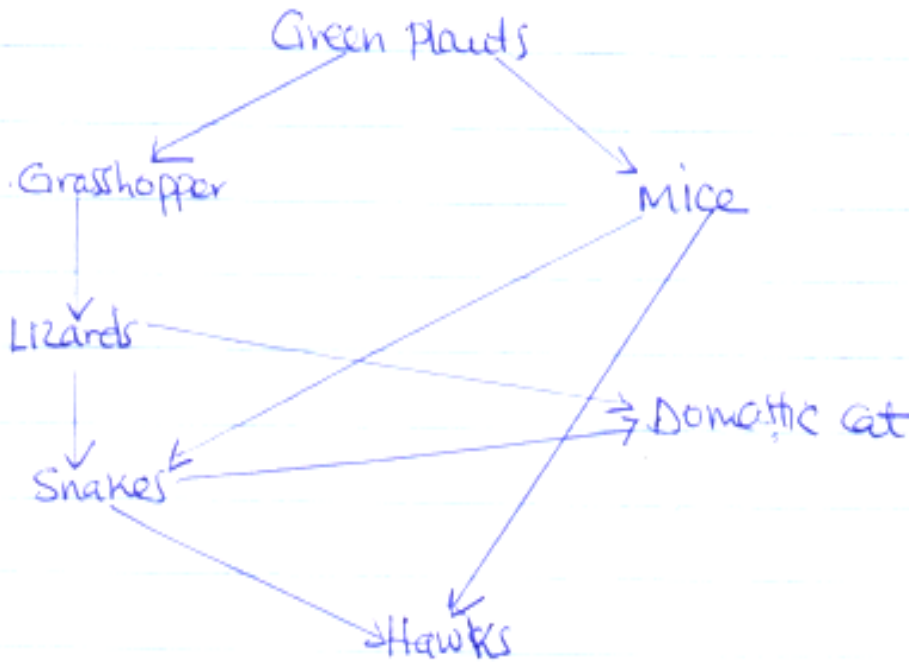

(a) Construct two food chains ending with a tertiary consumer in each case

(2mks)

(b) Suggest two ways in which the ecosystem would be affected if there was a prolonged drought

(2mks)



16. State two functions of muscles found in the alimentary canal of mammals (2mks)

.....

.....

.....

17. Study the reaction below and answer the questions that follow

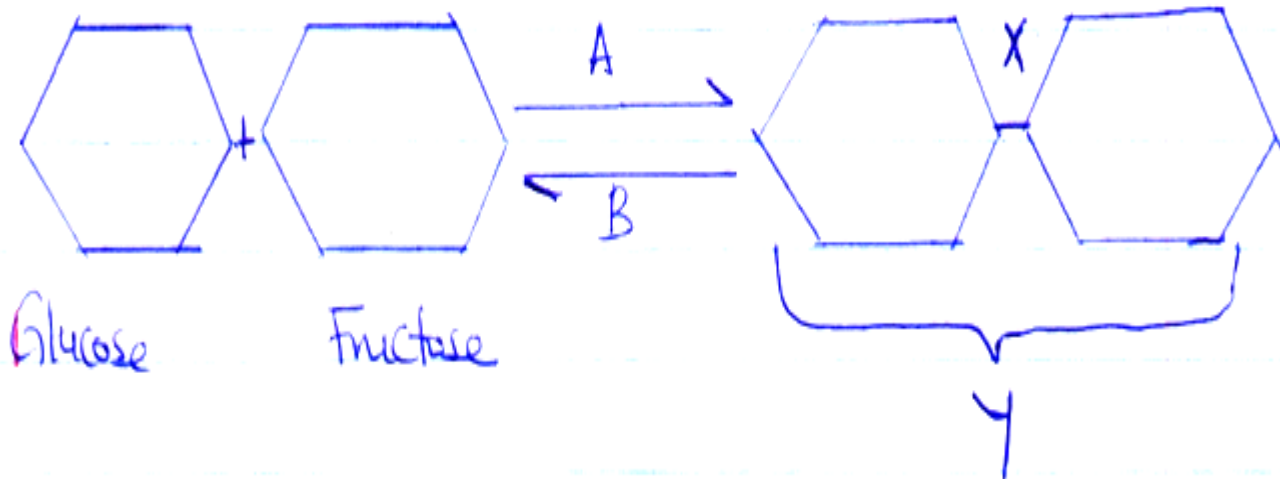

(a) What biological processes are represented by A and B (2mks)

A

.....

B

.....

(b) Identify the product Y (1mk)

.....

(c) State the bond represented by X (1mk)

.....

18. State one use of each of the following plant excretory products

(a) Tannins (1mk)

.....

.....

(b) Colchines (1mk)

.....

.....



(c) Quinine

(1mk)

19.State two characteristics of aerenchyma tissue

(2mks)

20. The table below shows the percentage composition by volume of inhaled and exhaled air

Gas	Inhaled air %	Exhaled air %
Oxygen	21	16
Carbon(iv) oxide	0.04	4.0
Nitrogen	79	79

(a) By what percentage is carbon (iv) oxide concentration in inhaled air higher than exhaled air **(2mks)**

(b) Explain the differences in the composition of the gases between inhaled and exhaled air **(3mks)**

21(a) What is metamorphosis

(1mk)



.....
.....
(b) What is the biological importance of the larval stage during metamorphosis (2mks)

.....
.....
22. Explain how the following forces contributes to the movement of water up the xylem vessels (2mks)

(a) Cohesion

.....
.....
(b) Adhesion

.....
.....
23. A solution of sugarcane was boiled with hydrochloric acid; sodium hydrogen carbonate was added to the solution which was then heated with benedict's solution. An orange precipitate was formed

(a) Why was the solution boiled with hydrochloric acid? (1mk)

.....
.....
(b) To which class of carbohydrates does sugarcane belong? 1mk

.....
.....
(c) State the form in which carbohydrates are stored in (2mks)

(i) Plants

.....
.....
(ii) Animals

.....
.....
24. How are lenticels adapted for gaseous exchange? (2mks)

.....
.....
25. State the importance of the following process that takes place in the nephrons of human kidney

(a) Ultrafiltration (1mk)



(b) Selective reabsorption

(1mk)

26. The diagram below represents a section or portion of a certain nucleic acid

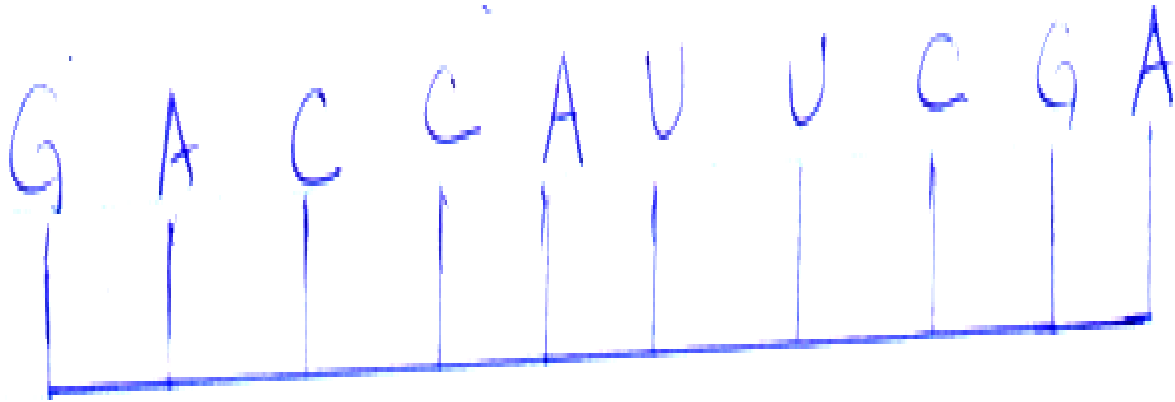

With a reason, identify the types of nucleic acid whose portion is shown above

Identity

1mk

Reason

1mk



KCSE 2021 PREDICTION

NAME.....

INDEX NO.....

SCHOOL.....

SIGN.....

DATE.....

231/2

BIOLOGY

PAPER 2

TIME: 2 HOURS

INSTRUCTIONS TO CANDIDATES:

- Write your name and admission number in the spaces provided.
- Sign and write the date of examination.
- This paper consists of **two** sections A and B.
- Answer **all** the questions in Section A in the spaces provided.
- In section B answer questions 6 (compulsory) and either question 7 or 8 in the spaces provided.
- Check and ascertain that no questions are missing.

For Examiner's Use Only:

SECTIONS	QUESTION	MAXIMUM SCORE	CANDIDATES SCORE
A	1	8	
	2	8	
	3	8	
	4	8	
	5	8	
B	6	20	
	7	20	
	8	20	
TOTAL SCORE		80	



©2021 The Kenya National Examinations Council

KCSE 2021 Prediction SET 3



SECTION A (40 MARKS)

Answer all questions in this section

- 1 (a) the table below shows the concentration of sodium and iodine ions in pond water and in the cell sap.

	<i>Sodium ion concentration</i>	<i>Iodine concentration</i>
<i>Pond water</i>	180	0.4
<i>Cell sap</i>	90	500

Giving reasons name the process through which each of the ions is taken up by the plants

- (i) Sodium ion

(2mks)

.....

.....

.....

.....

- (ii) Iodine ion

(2mks)

.....

.....

.....

.....

- (b) The lettuce plant was then treated with a chemical substance that inhibits the synthesis of ATP

Giving a reason, state which ion was affected by the treatment

(2mks)

.....

.....

.....

.....

- (c) Explain why fresh water fish cannot survive in marine habitat

(2mks)



2. The diagram below represents recycling of nutrients in a certain ecosystem

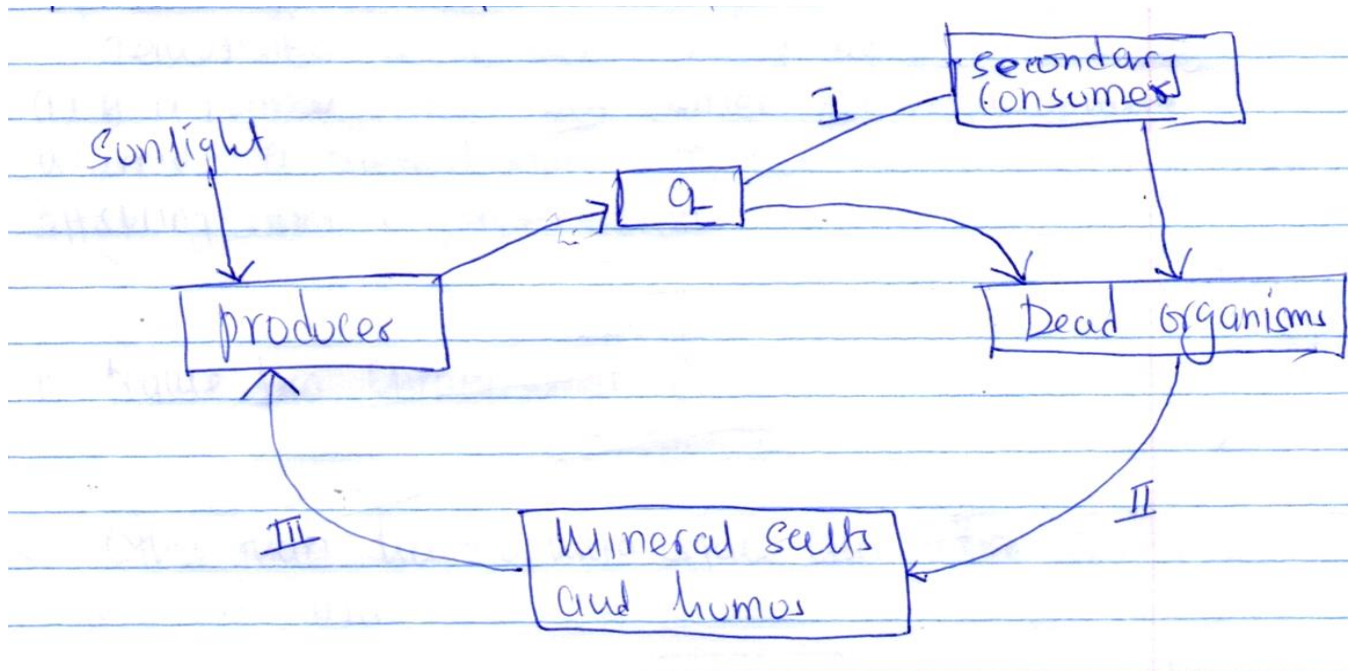

(a) Name the trophic level represented by Q

(1mk)

(b) Name the process represented by:

(3mks)

I

II

III

(c) Name the organism involved in process II

(1mk)



(d) What would happen within the ecosystem if all the secondary consumers were eliminated?

(3mks)

.....
.....
.....

3. (a) what is non disjunction

(1mk)

.....

(b) Haemophilia is a sex linked trait

(i) If a normal woman but carrier for haemophilia marries a normal man, work out the phenotype of the offspring using a genetic cross **(3mks)**

.....
.....
.....
.....
.....

(ii) Name two chromosomal disorders **(2mks)**

.....
.....







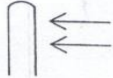

(c) Other than haemophilia, state any other two sex - linked defect in man

(2mks)

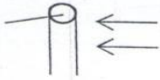
.....
.....

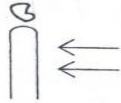
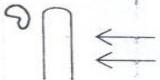
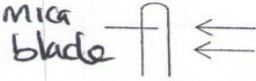
4. An experiment was set to investigate the effect of unilateral light on the growth of oat coleoptiles. The diagram in the table represents the experimental set ups the start and the result at the end of experiment.



Set up	Start of experiment	End of experiment
A		
B		
C		
D	<i>mica blade</i> 	<i>mica blade</i> 
E		

(a) Account for the reaction in experiment set up A (3mks)

.....

.....

.....

.....

.....

(b) Explain the purpose of experiment set up B and C (3mks)

.....

.....

.....

.....

.....

(c) Explain the results in the experiment set D and E (2mks)

D

.....

.....

E



5. The diagram below represents a transverse section through mammalian skin

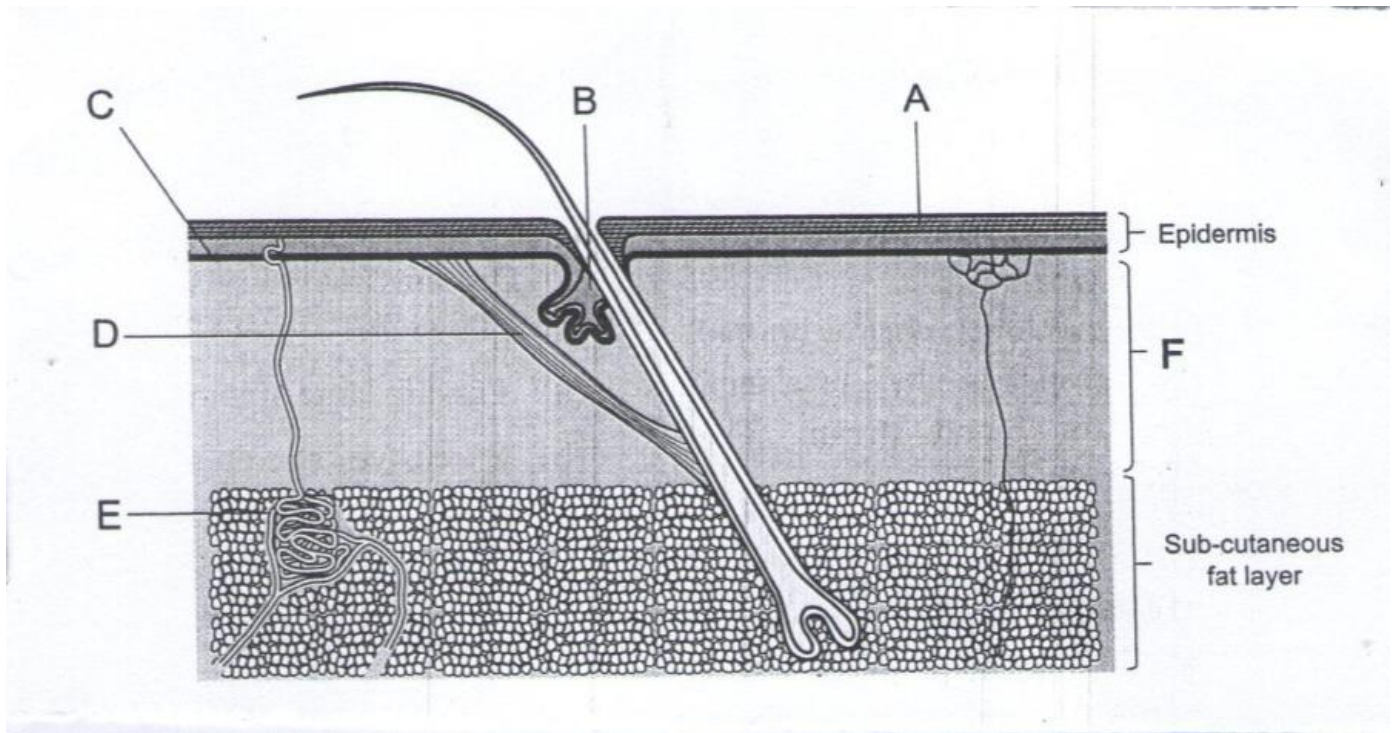

(a) Name the structures A and B

(2mks)

A.....
B.....

(b) (i) Explain how the hair in human beings helps in keeping the body warm

(3mks)

(ii) Explain other methods by which the skin helps to keep the body warm

(3mks)



SECTION B: (40MARKS)

Answer question 6 (compulsory) and either question 7 or 8 in the spaces provided.

6. The table below shows how the width of the stomata and the wind speed can affect the rate of transpiration from a leaf of a plant. The width are measured in micrometers (nm)

Width of stomata in (nm)	Rate of transpiration in gm/M ² / hour	
	In still air	In wind
0	0.0	0.0
5	0.9	4.0
10	16.0	7.0
15	2.0	8.4
20	2.2	9.0

- (a) On the same axes plot a graph of rate of transpiration against width of the stomata (8mks)

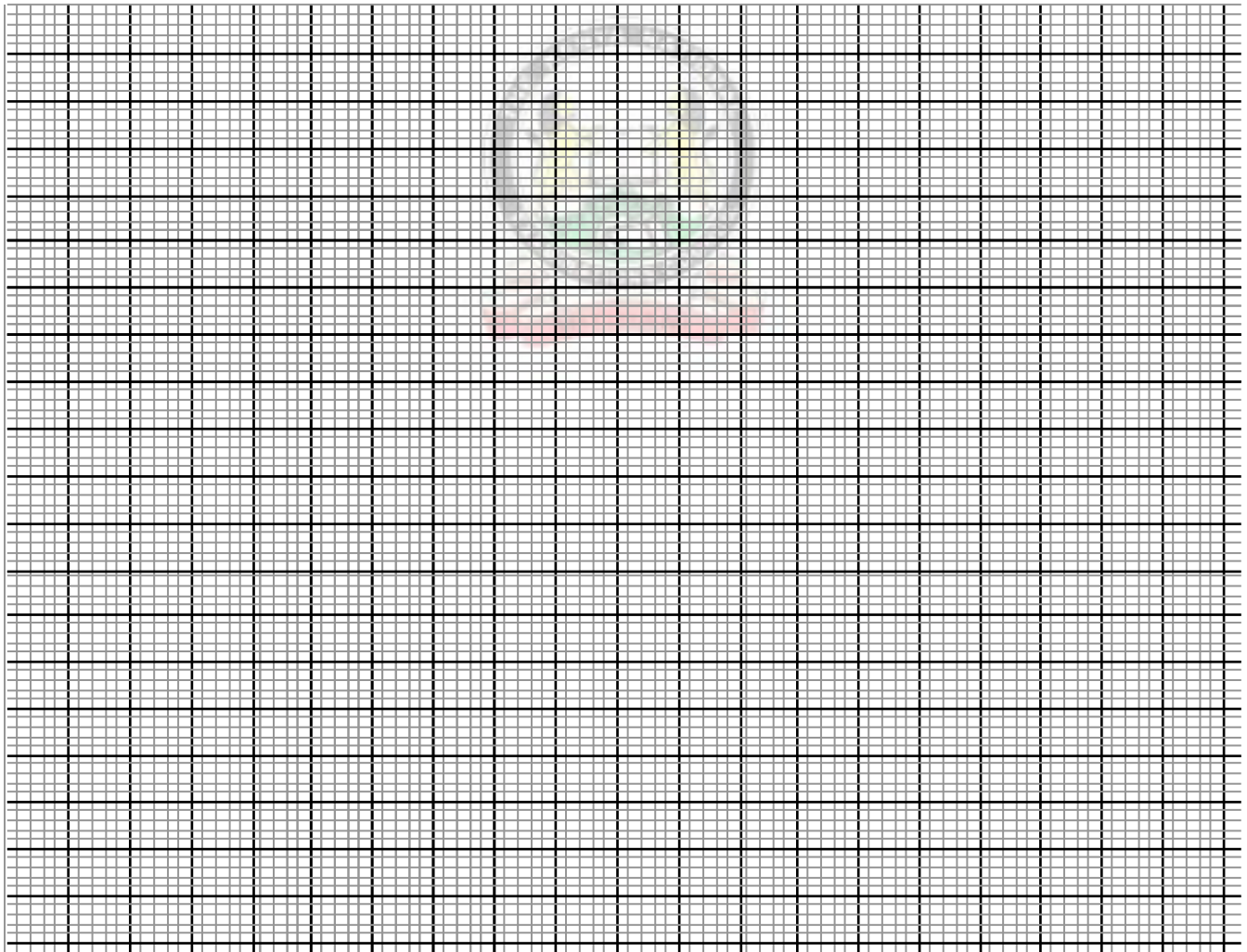

(b) Use your graph to predict the rate of transpiration when the stomata have a width of 8nm

.....
.....
.....

(c) Describe the relationship between the width of stomata and the rate of transpiration in still air

(3mks)

.....
.....
.....

(d) Explain why the rate of transpiration in wind differs from rate in still air

(3mks)

.....
.....
.....

(e) Explain why transpiration is important in plants

(4mks)

.....
.....
.....
.....
.....

7. Describe the various ways in which seeds and fruits are adapted for dispersal

(20mks)

8. (a) State the possible application of the following plants hormones in agriculture

(8mks)

(i) Auxins

(ii) Gibberellins

(b) Explain how each of the following serves as evidence of organic evolution

(i) Fossil records

(3mks)

(ii) Comparative anatomy

(6mks)

(iii) Geographical distribution

(3mks)



KCSE 2021 PREDICTION

NAME.....

INDEX NO.....

SCHOOL.....

SIGN.....

DATE.....

231/3

BIOLOGY

PAPER 3

TIME: 1 $\frac{3}{4}$ HOURS

INSTRUCTIONS TO CANDIDATES:

- Write your **name** and **admission number** in the spaces provided.
- Sign and write **date** of examination in the spaces provided above
- Answer **all** the questions in section A and B
- You are required to spend the first 15 minutes of the 1 $\frac{3}{4}$ hours allowed for this paper reading the whole paper carefully.

For Examiner's Use Only:

QUESTIONS	MAXIMUM SCORE	CANDIDATE'S SCORE
1	10	
2	16	
3	14	
TOTAL	40	



©2021 The Kenya National Examinations Council

KCSE 2021 Prediction SET 3



1.(a) Place 2ml of bicarbonate indicator in a clean test tube. Add dilute hydrochloric acid drop by drop and shake after each drop till there is a permanent color change.

(i) State the resulting color **1mk**

.....
.....
.....

(ii) To the mixture obtained above, now add sodium hydroxide solution dropwise until there is a permanent color change. Record your observations **1mk**

.....
.....

(iii) From your observations in a) i) and a) ii) above, what is the nature of the bicarbonate indicator **1mk**

.....
.....

(b) Place 10ml of a fresh bicarbonate indicator in boiling tube. Using a drinking straw, bubble air through the bicarbonate indicator until there is color change

(i) Record your observation **1mk**

.....
.....

(ii) What does the color obtained in b) i) above suggest about the nature of the gas breathed out **1mk**

.....
.....

c) Rinse the measuring cylinder and use it to place 2ml of lime water solution in a clean test tube. Rinse the drinking straw in (b) above and use it to bubble air through lime water solution

(i) Record your observation **1mk**

.....
.....

(ii) Suggest the identity of the gas that give rise to the observations above **1mk**

.....
.....



(d) (i) Name the physiological process in cells that leads to formation of gas named in (c)(ii) above **1mk**

(ii) Write down a word equation for the process named in (d) (i) above **1mk**

(iii) What is the importance of the identified process in cells of living organisms **1mk**

2. Below are photographs of two seedlings labeled K and L. Examine them.

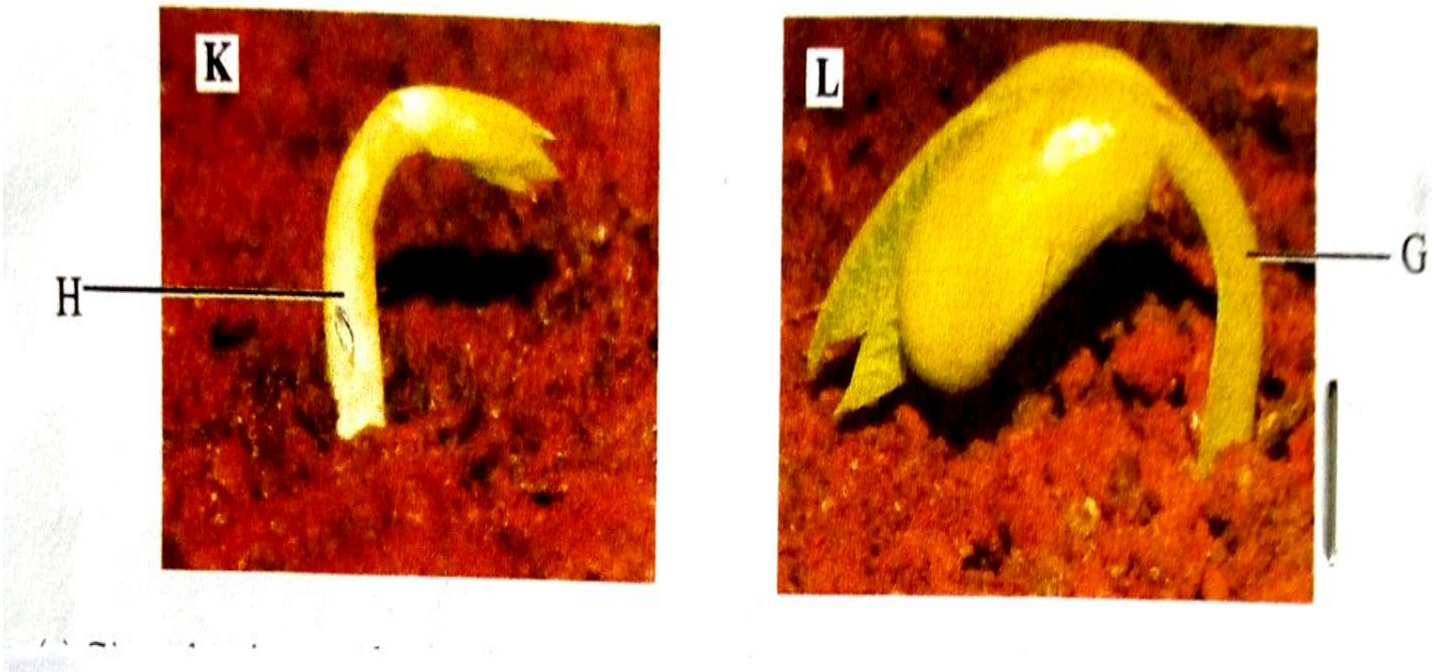

a) Given that the two plants belongs to the same class, name the class and give a reason based on the observable features in any of the two seedlings or both. **2mks**

Class

Reason(s)

b) i) State giving a reason, the type of germination that occurs in each of the two seedlings **4mks**

K

L

ii) Explain how the two types of germination you have stated in (b) (i) above occur **2mks**

K

L

c) Name the parts labelled H and G on the seedling **2mks**

H

G

d) As germination progresses, both seedlings straightens. Explain how this occurs. **4mks**

e) Name the type(s) of root system that will develop in the two seedlings **1mk**



f) State another observation that will be made as seedling L straightens 1mk

3. The photographs below are specimens from the same animal of two different bones each shown in two views. Examine them.

Bone V
anterior view

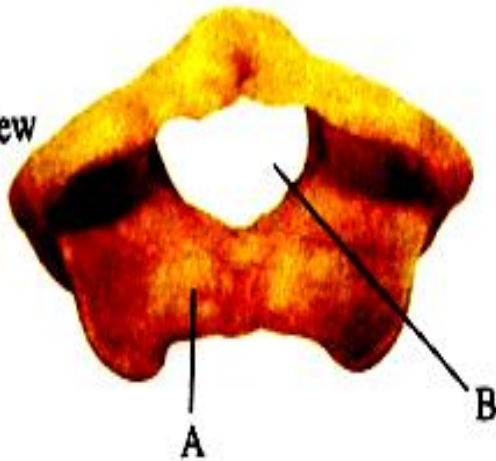

Bone V
posterior view

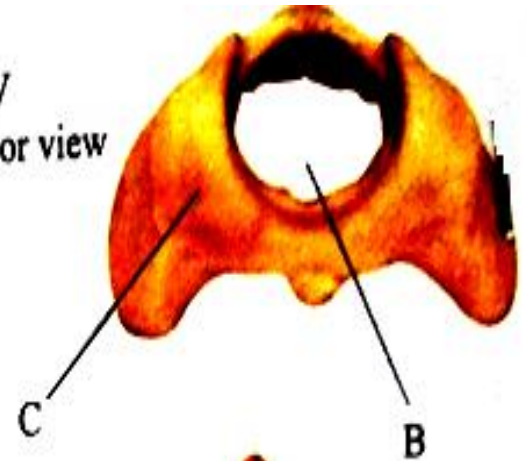

Bone W
anterior view

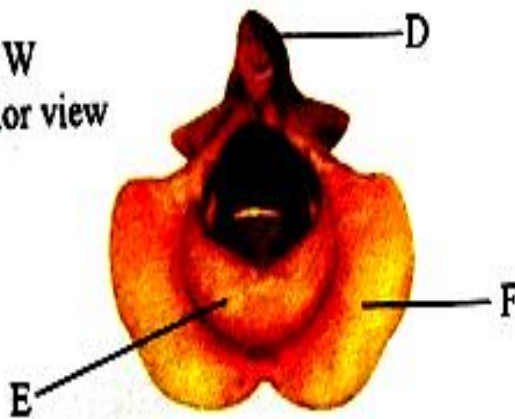

Bone W
posterior view

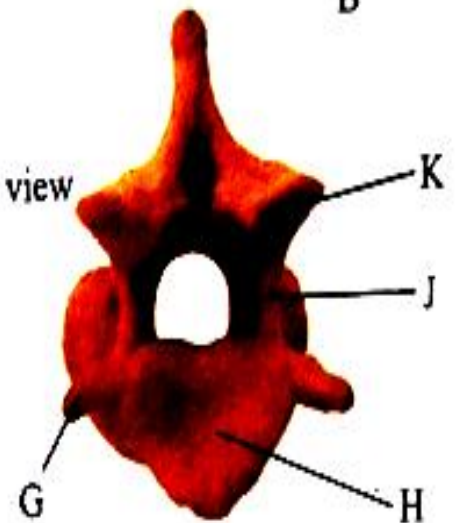

a) Identify the two specimens 2mks

Specimen V.....

Specimen W.....

b) Give four observable differences between bones V and W 4mks

Bone V	Bone W



c) Name the structure that articulates with part labeled A **1mk**

.....

d) State two roles of opening labeled B **2mks**

.....
.....
.....

e) Name the part labelled E and state its role **2mks**

Name

.....

Role

.....
.....

f) Which of the labelled part(s) are used for articulation with adjacent vertebra **1mk**

.....

g) State a common role of the parts labelled H and J **1mk**

.....
.....

h) Which of the labeled part(s) is(are) used for muscle attachment **1mk**

.....
.....



KCSE 2021 PREDICTION

NAME.....

INDEX NO.....

SCHOOL.....

SIGN.....

DATE.....

121/1

MATHEMATICS

PAPER 1

TIME: 2 HOURS 30 MINUTES

INSTRUCTIONS TO CANDIDATES:

- Write your **name**, **admission number**, **Signature** and write **date** of examination in the spaces provided
- The paper contains **two** sections. Section I and Section II.
- Answer **ALL** the questions in section I and any **five** questions in section II.
- Answers and working **must** be written on the question paper in the spaces provided below each question.
- Show all steps in your calculations below each question.
- Marks may be given for correct working even if the answer is wrong.
- Non programmable silent electronic calculators and KNEC mathematical table may be used, except where stated otherwise.

FOR EXAMINERS USE ONLY

SECTION I

Question	1	2	3	4	5	6	7	8	9	10	11	12	13	14	15	16	TOTAL
Marks																	

SECTION II

Question	17	18	19	20	21	22	23	24	TOTAL
Marks									

GRAND TOTAL

--



©2021 The Kenya National Examinations Council

KCSE 2021 Prediction SET 3



SECTION I (50 MARKS)

Answer all the questions from this section

1. Without using a calculator evaluate

(3 marks)

$$\frac{-2(-5 + 8) - 9 \div 3 - 5}{-3 \times -5 + -2 \times 4}$$

2. (a) use mathematical tables to find the:

(i) The square of 86.46

(1 mark)

(ii) The reciprocal of 27.56

(1 mark)



(b) Hence or otherwise calculate the value of;

(2 marks)

$$\frac{86.46^2}{27.56}$$

3. The sum of the interior angles of an n – sided polygon is 1440° . Find the value of n and hence deduce the name of the polygon. **(3 marks)**



4. Two containers have base areas of 750cm^2 and 120cm^2 respectively. Calculate the volume of the larger container in litres given that the volume of the smaller container is 400cm^3 .

(3 marks)



For Marking Schemes Contact 0707-550-000 / 0705-525-657

5. Given that the column vectors $\mathbf{a} = \begin{pmatrix} -1 \\ 4 \end{pmatrix}$, $\mathbf{b} = \begin{pmatrix} -3 \\ -2 \end{pmatrix}$ and $\mathbf{c} = \begin{pmatrix} -2 \\ -1 \end{pmatrix}$ and that $\mathbf{P} = 2\mathbf{a} - 4\mathbf{b} + 3\mathbf{c}$. Express P as a column vector. **(3 marks)**

6. Solve the following inequalities and represent the range of values of x on a single number line. **(3 marks)**

$$5 - 3x > -7$$

$$x - 6 \leq 3x - 4$$



©2021 The Kenya National Examinations Council

KCSE 2021 Prediction SET 3



For Marking Schemes Contact 0707-550-000 / 0705-525-657

7. The cost of a car outside Kenya is US \$ 4800. You intend to buy one such car through an agent who deals with Japanese Yen. The agent will charge 15% commission on the price of the car and further 72 220 Japanese Yens for shipment of the car. How many Kenya shillings will you need to send to the agent to obtain the car given that:

1 US \$ = 117.20 Japanese Yens

1US \$ = Kshs 72.34

(3 marks)



8. Two numbers p and q are such that $p^3 \times q = 189$. Find p and q

(3 marks)



©2021 The Kenya National Examinations Council

KCSE 2021 Prediction SET 3



9. Evaluate without using mathematical tables.

(3 marks)

$$1000 \left(\sqrt{\frac{0.0128}{200}} \right)$$

10. Simplify the following expression by reducing it to a single fraction.

(3 marks)

$$\frac{2x - 3}{3} - \frac{x - 2}{2} - \frac{1 - x}{4}$$



11. Thirty men working at a rate of 10 hours a day can complete a job in 14 days. Find how long it would take 40 men working at the rate of 7 hours a day to complete the same job.

(3 marks)

12. The figure below shows a circle centre O and radius 6cm. sector OAB subtends an angle of 100° at the centre of the circle as shown.

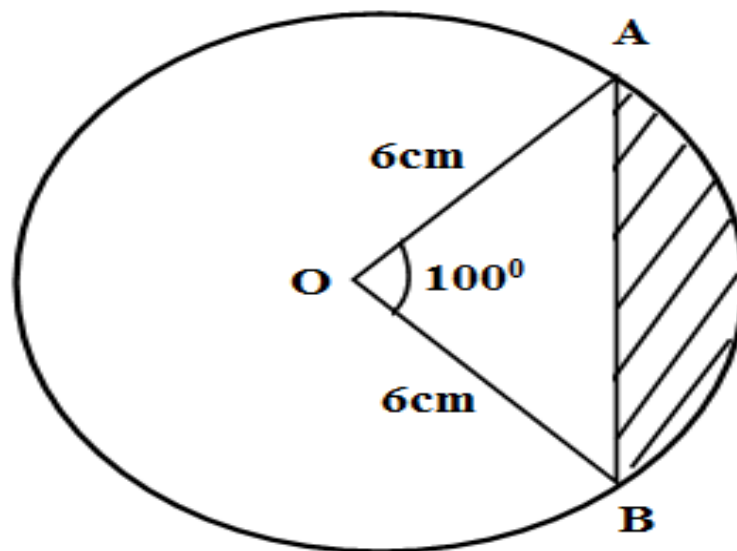

Calculate to 2 decimal places the area of the shaded region. (Take $\pi = \frac{22}{7}$)

(3 marks)

13. Use the prime factors of 1764 and 2744 to evaluate

$$\frac{\sqrt{1764}}{\sqrt[3]{2744}}$$

(3 marks)

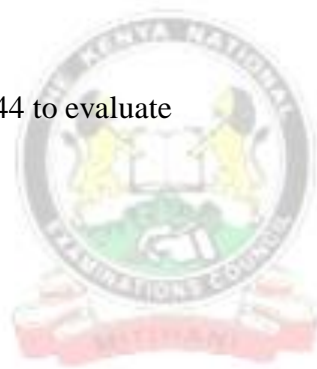

For Marking Schemes Contact 0707-550-000 / 0705-525-657

- 14.** A rectangular block is 50cm long and 15 cm wide. If its mass is 18kg and its density is 2.4g/cm^3 , find its height. **(3 marks)**

- 15.** A triangle ABC is such that $AB = 12\text{cm}$, and $AC = 17\text{cm}$. if its area is 512cm^2 , find the size of angle BAC **(3 marks)**

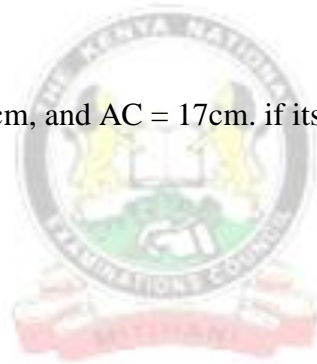

©2021 The Kenya National Examinations Council

KCSE 2021 Prediction SET 3



16. (a) Find the greatest common divisor of the terms $9x^3y^2$ and $4xy^4$ (1 mark)

(b) Hence factorize completely the expression (2 marks)

$$9x^3y^2 - 4xy^4$$



SECTION II (50 MARKS)

Answer FIVE questions ONLY from this section

17. A straight line $y = \frac{2}{3}x - \frac{2}{3}$ meets the x – axis at point T.

(a) Determine the coordinates of T.

(2 marks)

(b) A second line L_2 is perpendicular to line L_1 at T. Find the equation of line L_2 in the form $ax + by = c$ where a, b and c are constants.

(3 marks)



(c) A third line L_3 passes through $(-4,1)$ and is parallel to L_1 . Find;

(i) The equation of line L_3 in the form $y = mx + c$

(2 marks)



- (ii) The coordinates of point S at which L_3 intersects L_2 .

(3 marks)



18. A particle moves in a straight line so that its velocity is given by $V = \frac{1}{2}t^2 - 3t + 7$ where t is time in seconds. Find:

(a) The velocity after 8 seconds.

(2 marks)

(b) The acceleration when $t = 0$

(2 marks)



(c) The minimum velocity attained.

(2 marks)



(d) The distance travelled in the first 2 seconds.

(4 marks)



19. The points $A^I B^I C^I$ are the images of $A(4, 1)$, $B(0, 2)$ and $C(-2, 4)$ respectively under a transformation represented by the matrix $M = \begin{pmatrix} 1 & 1 \\ 1 & 3 \end{pmatrix}$.

(a) Write down the coordinates of $A^I B^I C^I$ (3 marks)

(b) $A^{II} B^{II} C^{II}$ are the images of $A^I B^I C^I$ under another transformation whose matrix is $N = \begin{pmatrix} 2 & -1 \\ 1 & 2 \end{pmatrix}$. Write down the co-ordinates of $A^{II} B^{II} C^{II}$ (3 marks)

(c) Transformation M followed by N can be replaced by a single transformation P. determine the matrix for P. (2 marks)



(d) Hence determine the inverse of matrix P.

(2 marks)



20. The distance between two towns A and B is 460 km. a minibus left town A at 8.45 am and travelled towards B at an average speed of 65km/hr. A matatu left B at 10.55 am on the same day and travelled towards A at an average speed of 80km/hr.

(a) How far from town B did they meet? **(4 marks)**

(b) At what time did the two vehicles meet? **(2 marks)**



(c) A motorist started from his home at 9.15am on the same day and travelled to B at an average speed of 120km/hr. he arrived at the same time as the minibus. Calculate the distance from B to his home.

(4 marks)



21. A paper cup is made in the shape of a frustum of a cone with an open top of diameter 10.5cm and a sealed bottom of diameter 7cm. it has a depth of 12cm, calculate:

(a) The total surface area of the cup. **(6 marks)**



(b) The capacity of the cup to the nearest deciliter. **(4 marks)**



22. The table below shows the marks scored by form four students in a mathematics test in Bidii secondary school.

Marks (%)	40 – 44	45 – 49	50 – 54	55 – 59	60 – 64	65 – 69	70 – 74
No of students	3	30	29	33	13	1	1

(a) State the modal class. (1 mark)

(b) Using an assumed mean of 57, calculate:

(i) The mean (3 marks)



(ii) The standard deviation. (3 marks)

(c) Find the mark scored by the 50th student. (3 marks)



23. The figure below shows triangle XYZ in which line XY = 5cm, line YZ = 13.4cm and the size of angle XYZ = 57.7°

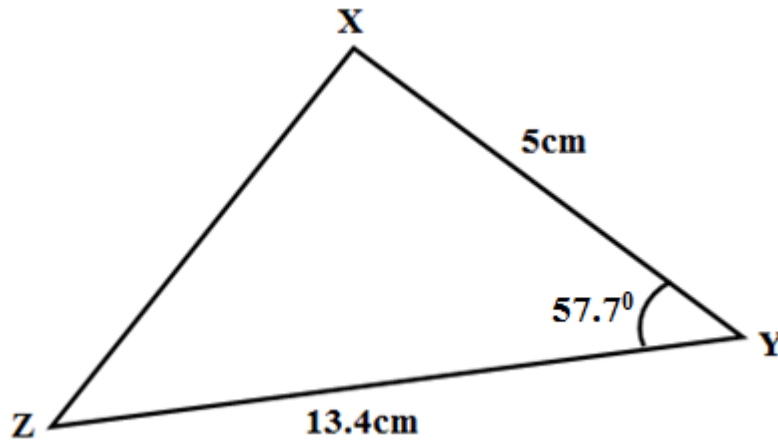

- (a) Calculate the length of line XZ (4 marks)

- (b) Calculate the size of angle XZY (4 marks)

- (c) Calculate the size of angle YXZ to 4 significant figures (2 marks)



24. Four towns P,Q,R and S are such that town P is 200 km West of Q. Town R is at a distance of 80km on a bearing of 049^0 from P. Town S is due East of R and due North Of Q.

- (a) Using a scale of 1cm to represent 20km, make an accurate scale drawing to show the relative positions of the towns. **(4 marks)**



(b) Find:

- (i) Determine the bearing of S from P **(1mark)**

- (ii) Determine the distance of Q from S **(2 marks)**

- (iii) Determine the bearing of Q from R **(1 mark)**

- (iv) Determine the distance of R from S **(2 marks)**



KCSE 2021 PREDICTION

NAME.....

INDEX NO.....

SCHOOL.....

SIGN.....

DATE.....

121/2

MATHEMATICS

PAPER 2

TIME: 2 HOURS 30 MINUTES

INSTRUCTIONS TO CANDIDATES:

- Write your **name**, **admission number**, **Signature** and write **date** of examination in the spaces provided
- The paper contains **two** sections. Section I and Section II.
- Answer **ALL** the questions in section I and any **five** questions in section II.
- Answers and working **must** be written on the question paper in the spaces provided below each question.
- Show all steps in your calculations below each question.
- Marks may be given for correct working even if the answer is wrong.
- Non programmable silent electronic calculators and KNEC mathematical table may be used, except where stated otherwise.

FOR EXAMINERS USE ONLY

SECTION I

Question	1	2	3	4	5	6	7	8	9	10	11	12	13	14	15	16	TOTAL
Marks																	

SECTION II

Question	17	18	19	20	21	22	23	24	TOTAL
Marks									

GRAND TOTAL

--



©2021 The Kenya National Examinations Council

KCSE 2021 Prediction SET 3



SECTION I (50 MARKS)

Answer all the questions from this section

1. Use Logarithms correct to four significant figures to evaluate.

(4marks)

$$\sqrt[3]{\frac{24.36 \times 0.066547}{1.48^2}}$$

2. Find the percentage error in the total length of four rods measuring 12.5cm, 24.5cm, 12.9cm and 10.1cm all the nearest 0.1cm.

(3 marks)

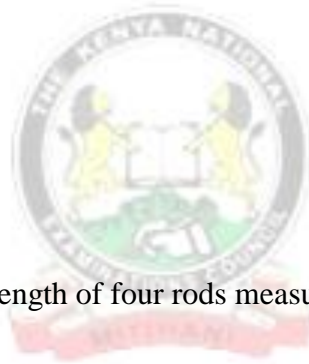

3. In the figure below QT is a tangent to the circle at Q. PXRT and QXS are straight lines.
PX = 6cm, RT = 8cm, QX = 4.8cm and XS = 5cm.

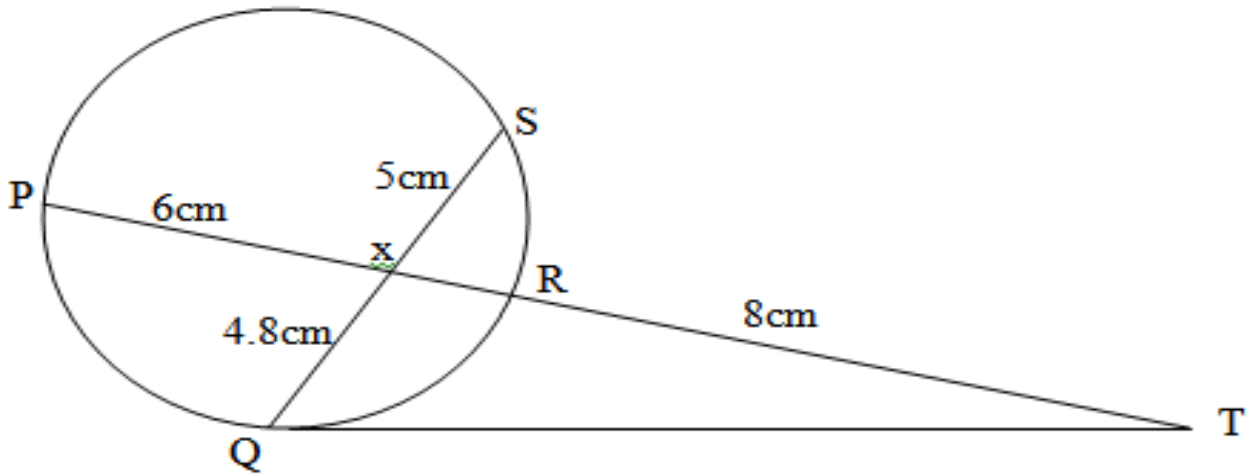

Find the length of QT

(3 marks)



4. Use the trapezium rule with seven ordinates to find the area bounded by the curve $y = x^2 + 1$ lines $x = -2$, $x = 4$ and x - axis (3 marks)



5. Given that $x = \sqrt{\frac{tp}{2\mu+p}}$ make p the subject of the formula **(3 marks)**

6. Solve for x in the equation below:

$$\text{Log } 3(x + 3) = 3 \log 3 + 2$$

(3 marks)



7. The points (5, 5) and (-3, -1) are ends of a diameter of a circle centre A. Determine:

a) The coordinates of A.

(1 mark)

b) The equation of a circle expressing it in form $x^2 + y^2 + ax + by + c = 0$

(2 marks)



8. A transformation is represented by the matrix $\begin{bmatrix} 1 & 3 \\ 4 & 2 \end{bmatrix}$. This transformation maps a triangle ABC of the area 12.5cm^2 onto another triangle A'B'C'. Find the area of triangle A'B'C'.

(3marks)

9. Two taps A and B can fill a water bath in 8 minutes and 10 minutes respectively. Tap A is opened for 2 minutes then closed. Tap B is later opened for one minute then closed. How long will the two taps take running together to fill the remaining part of the water bath?

(3 marks)

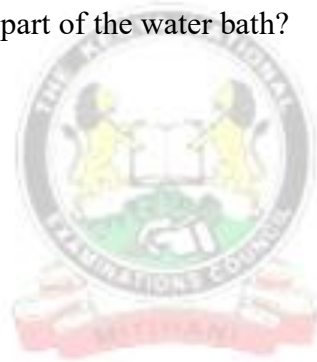

10. i) Expand and simplify $(1-3x)^5$ up to the term in x^3

(2 marks)

- ii) Hence use your expansion to estimate $(0.97)^5$ correct to 4d.p.

(2 marks)



11. Solve for x in the equation:

$$2\cos 4x = -1 \text{ for } 0^\circ \leq x \leq 180^\circ$$

(3 marks)

12. Wanjiku pays for a car on hire purchase in 15 monthly instalments. The cash price of the car is Ksh.300,000 and the interest rate is 15%p.a. A deposit of Ksh.75,000 is made. Calculate her monthly repayments.

(3 marks)



13. The gradient function of a curve is given $\frac{dy}{dx} = 3x^2 - 8x + 2$. If the curve passes through the point, (2, -2),

find its equation.

(3 marks)



14. Rationalize the denominator and simplify

(3 marks)

$$\frac{2\sqrt{5}(\sqrt{5} - 2)}{(\sqrt{5} + 2)(\sqrt{5} - 2)}$$

15. The sum of two numbers is 24. The difference of their squares is 144. What are the two numbers?

(3marks)



16. The data below represents the marks scored by 15 form 4 students in an exam:

58, 61, 40, 37, 39, 40, 41, 43, 44, 37, 70, 44, 47, 36 and 52

Calculate the interquartile range of the above data

(3 marks)



SECTION II (50 MARKS)

Answer five questions only from this section

17. The following table shows the rate at which income tax was charged during a certain year.

Monthly taxable income in Ksh.	Tax rate %
0 - 9860	10
9861 - 19720	15
19721 - 29580	20
29581 - 39440	25
39441 - 49300	30
49301 - 59160	35
over 59160	40

A civil servant earns a basic salary of Ksh.35750 and a monthly house allowance of sh.12500. The civil servant is entitled to a personal relief of sh.1062 per month. Calculate:

a) Taxable income (2 marks)

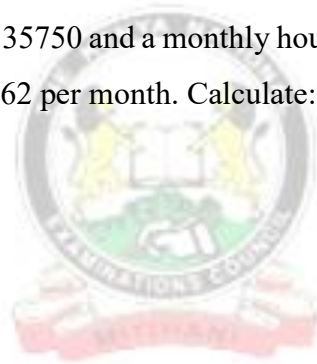

b) Calculate his net monthly tax (5 marks)



c) Apart from the salary the following deduction are also made from his monthly income.

WCPS at 2% of the basic salary

Loan repayment Ksh.1325

NHIF sh.480

Calculate his net monthly earning.

(3 marks)



18. The diagram below represents a cuboid ABCDEFGH in which $FG = 4.5$ cm, $GH = 8$ cm and $HC = 6$ cm

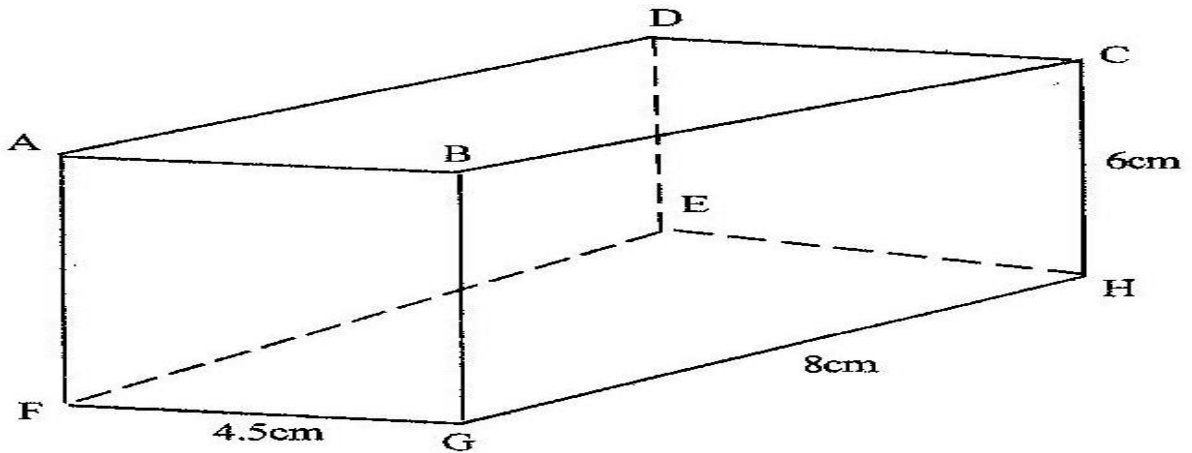

Calculate:

a) The length of FC (2 marks)

b) (i) The size of the angle between the lines FC and FH (2 marks)

(ii) The size of the angle between the lines AB and FH (3 marks)

c) The size of the angle between the planes ABHE and the plane FGHE (3 marks)



19. A plane S flies from a point P (40°N , 45°W) to a point Q (35°N , 45°W) and then to another point T (35°N , 135°E).

a) Given that the radius of the earth is 6370km find the distance from P to Q in Km.

(Take $\pi = \frac{22}{7}$)

(2 marks)

b) Find in nm

(i) The shortest distance between Q and T.

(2 marks)

(ii) The longest distance between Q and T (to the nearest tens)

(2 marks)

c) Find the difference in time taken when S flies along the shortest and longest routes if its speed is 420 knots

(4 marks)

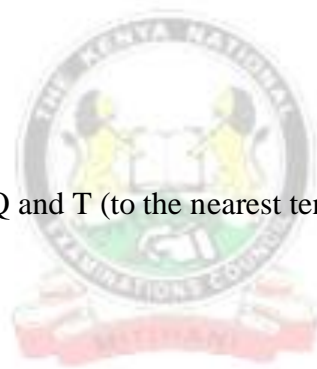

20. The probability that a pupil goes to school by a boda-boda is $\frac{2}{3}$ and by a matatu is $\frac{1}{4}$. If he uses a boda-boda the probability that he is late is $\frac{2}{5}$ and if he uses matatu the probability of being late is $\frac{3}{10}$. If he uses other means of transport the probability of being late is $\frac{3}{20}$.

a) Draw a tree diagram to represent this information. **(3marks)**

b) Find the probability that he will be late for school. **(3marks)**



c) Find the probability that he will be late for school if he does not use a matatu. **(2marks)**

d) What is the probability that he will not be late to school? **(2marks)**



21. A farmer has 50 acres of land. He has a capital Shs. 2,400 to grow carrots and potatoes as cash crops. The cost of growing carrots is Shs.40 per acre and that of growing potatoes is Shs.60 per acre. He estimates that the respective profits per acre are Shs.30 (on carrots) and Shs. 40 (on potatoes). By letting x and y to represent carrots and potatoes respectively:-

a) Form suitable inequalities to represent this information. **(4marks)**

b) b) By representing this information on a graph, determine on how many acres he should grow each crop for maximum profit. **(4marks)**

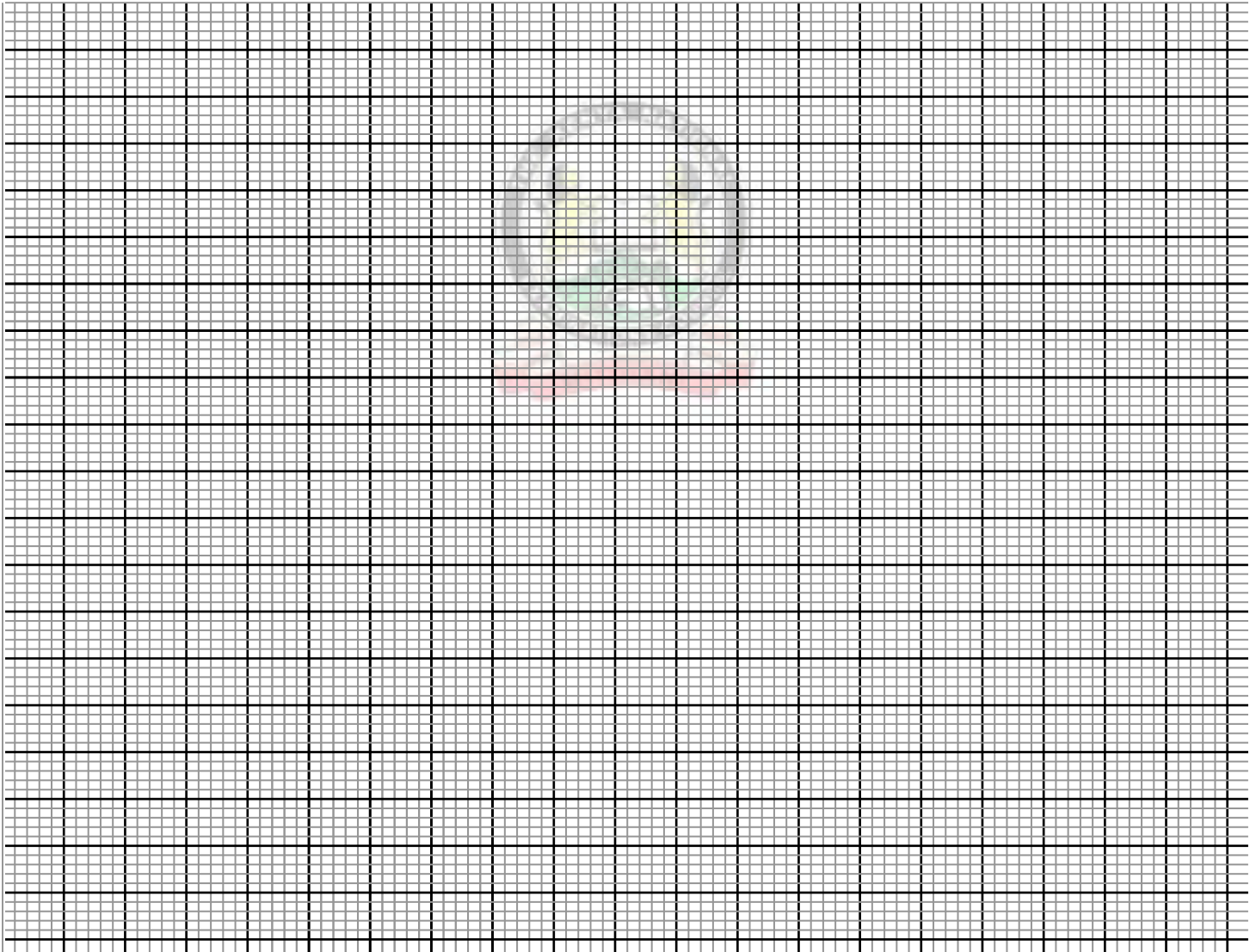

c) Find the maximum profit.

(2 marks)



22. An arithmetic progression is such that the first term is -5 , the last term is 135 and the sum of the progression is 975 .

(a) Calculate

(i) The number of terms in the series **(4 marks)**

(ii) The common difference of the progression **(2 marks)**

(c) The sum of the first three terms of a geometric progression is 27 and first term is 36 .
Determine the common ratio and the value of the fourth term **(4 marks)**



23. In the figure below E is the midpoint of BC. AD: DC 3:2 and F is the meeting point of BD and AE.

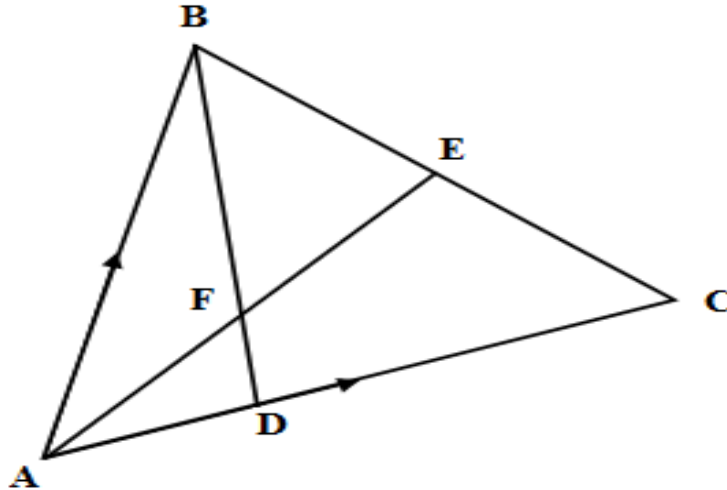

a) If $AB = \mathbf{b}$ and $AC = \mathbf{c}$, find:

i) BD

(2marks)

ii) AE

(2marks)

b) If $BF = t BD$ and $AF = n AE$. Find the value of t and n .

(5marks)

c) State the ratio of BD to BF .

(1mark)



d)

24. Given that $y = 2\sin 2x$ and $y = 3\cos (x + 45^\circ)$

(a) Complete the table below.

(2mks)

x	0°	20°	40°	60°	80°	100°	120°	140°	160°	180°
2sin x	0		1.97		0.68	-0.68	-1.73		-1.28	0.00
3cos (x+ 45°)	2.12	1.27		-0.78		-2.46			-2.72	-2.12

(b) Use the data to draw the graphs of $y = 2 \sin 2x$ and $y = 3 \cos (x + 45^\circ)$ for $0^\circ \leq x \leq 180^\circ$ on the same axes. **(4marks)**

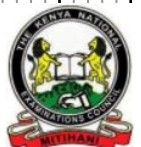
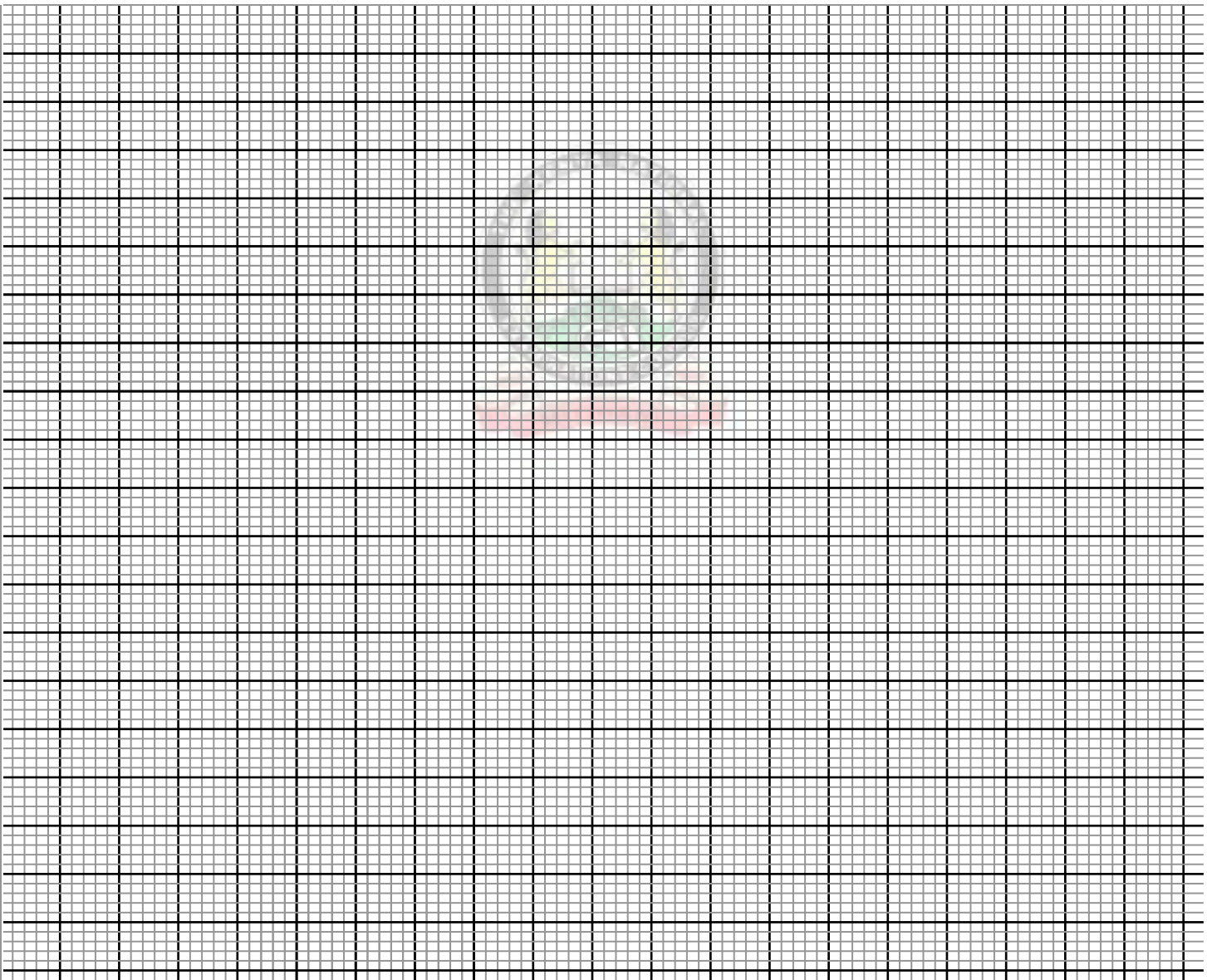

For Marking Schemes Contact 0707-550-000 / 0705-525-657

(c) State the amplitude and period of each curve.

(2marks)

(d) Use the graph to solve the equation $2 \sin 2x - 3 \cos (x + 45^\circ) = 0$ for $0^\circ \leq x \leq 180^\circ$

(2marks)



©2021 *The Kenya National Examinations Council*

KCSE 2021 Prediction SET 3



KCSE 2021 PREDICTION

NAME.....

INDEX NO.....

SCHOOL.....

SIGN.....

DATE.....

101/1

ENGLISH (Functional Skills)

TIME: 2 HOURS

INSTRUCTIONS TO CANDIDATES

- Write your *Name*, *Admission number* and *Class* in the spaces provided above.
- *Sign* and write the *date* of examination in the spaces provided above.
- Answer *all* questions in this question paper.

For Examiner's Use Only:

QUESTION	MAXIMUM SCORE	CANDIDATE'S SCORE
1	20	
2	10	
3	30	
TOTAL SCORE	60	



2. Read the passage below and fill in the blanks with the most appropriate word. (10mks)

Addiction is an escape (1).....reality, and different people will find different (2)..... to escape from the real world. They can be addicted to food water, power, work, gambling, sex, love (3) even to destructive relationships. Do these belong in the same category (4)..... alcohol or drugs? And if so, does recovery from those “people addictions” work the same way as with alcohol and drugs?

Addicts look for substitutes, and (5).....reason behind this is always the same: to escape, to close one eye and not to (6).....the facts. By becoming fat, the overeater insulates himself from the world around. It is better to be rejected (7).....the way they look, than for who they are as a person. Thus, being fat becomes a way to avoid the risk of intimacy. There are people who are (8)..... to work. (9).....will go home late, just to avoid interaction with the family. Workaholism is a dysfunctional attempt to earn self – esteem byProductive.

3. Oral skills (30marks)

(a) Read the poem below and answer the questions that follow.

I wonder by the edge
Of this desolate lake
Where wind cries in the sledge
Until the axle break
That keeps the stars in their round
And hands hurt in the deep
The banners of east and west
And the girdle of light is unbound,
Your breast will not lie by the breast
Of your beloved in sleep

(i) Describe the rhyme scheme of the poem.

(2mks)



.....
.....
.....
(ii) Identify and illustrate any two sound pattern used in the poem (4mks)

.....
.....
.....
(iii) How would you say the last two lines of the poem? (2mks)

.....
.....
.....
(iv) Give homophones for the following words used in the poem (2mks)

Wonder –

Break-



(b) Underline the word that is said differently from the sets of words given below. (4mks)

- | | | |
|------------|--------|---------|
| (i) Fairy | ferry | furry |
| (ii) Floor | flower | flour |
| (iii) Pear | pare | peer |
| (iv) Canal | kernel | colonel |

(c) During a presentation you were interrupted severally by some members of the audience. Give three reasons why the audience would do so. (3mks)



.....
.....
(d) Classify the words below according to the pronunciation of sounds /s/ and /z/

See, raise, miser, pieces, waste, days (3mks)

.....
.....
(e) You have been summoned in a court of law after being arrested in a swoop targeting hawkers.

You have been put on your defence (10marks)

Prosecutor: is your name James Wambua

You:

.....

.....

(2marks)

Prosecutor: (*addressing the magistrate*) sorry for that mix – up your honour the name is James Wambura not James Wambua.

(*to the defendant*) You are accused of contravening the city by laws CAP 16/2B of the county Government by hawking goods without a license. What is your plea?

You:

.....

.....

(2marks)

Prosecutor: If you were truly coming from school, would you prove to this court that you are really a student?

You:



.....
.....
(2marks)

Prosecutor: (*passing some document to the magistrate*) your honour the document looks genuine and has a school stamp (*To the defendant*) but exactly where were you arrested and what were you doing there at that time?

You:
.....
.....
(2marks)

Prosecutor: (*to the magistrate*) your honour since the accused is a minor, I have no intention of proceeding with the prosecution of this case.

Magistrate: alright: case dismissed.

You:
.....
.....
(2marks)



KCSE 2021 PREDICTION

NAME.....

INDEX NO.....

SCHOOL.....

SIGN.....

DATE.....

101/2

ENGLISH

(COMPREHENSION, LITERARY, APPRECIATION AND GRAMMAR)

PAPER 2

TIME: 2 ½ HOURS

INSTRUCTIONS TO CANDIDATES

- Write *your name and admission number* in the spaces provided.
- Sign and write the *date* of examination in the spaces provided above.
- Answer *all* questions in this question paper.
- Answers to all questions *must* be written in the spaces provided in this booklet.

For Examiner's Use Only

QUESTION	MAXIMUM SCORES	CANDIDATE'S SCORES
1	20	
2	25	
3	20	
4	15	
Total Score	80	



©2021 The Kenya National Examinations Council

KCSE 2021 Prediction SET 3



QUESTION 1

(20mks)

Read the passage below and answer the questions that follow

Cities and towns are experiencing massive population growth the world over receiving huge numbers of migrants ever year.

In 1950, urban population accounted for only 29 percent of the world population, according to the United Nations Educational Scientific and Cultural Organization (UNESCO). At the turn of the century, the figure had risen to 45percent. This was enough to declare the Twentieth Century the century of urbanization and city life. Now the figure is projected to hit 70 percent by 2025.

In Africa, urbanization is most intense in Algeria, Tunisia and South Africa, which have more than 50 percent of their population living in urban areas. Generally, cities in the developing world are growing at a rate of 3.5 per cent per annum.

These figures indicate that there is a continuous massive movement of people from rural to urban areas worldwide. Driven by the desire for better living conditions, they flock to cities in droves in search of greener pastures. But, slowly the **illusion** disappears, and is replaced by harsh realities of urbanism: unemployment or underemployment, crime, poverty, hunger and life in the slums.

To cope with this fast – moving wave of rural flight requires new strategies for urban planning and the use of urban spaces. Thus urban planners, policymakers and governments seek **pragmatic** and timely ways of addressing this challenge. The process of urbanization transforms land use and farming systems, patterns of labour force participation, infrastructural requirements, and natural resource systems. When cities grow, their population expands, putting a strain on food production.

As a way of easing the food shortage, many urban households, particularly the poor, have taken to growing food on small plots. Today, if you take a walk through some of the residential estates in Nairobi such as Ngara, Eastleigh and Buru Buru, you might be forgiven for thinking that a green revolution is under way. And on the outskirts of the city, green – houses and ponds compete for space with small gardens planted with flowers, vegetables and fruits. Banana plants and palm trees dwarf wrought – iron gates, their green dotting the skyline, Kale, cabbage and maize gardens sprout in the middle of urban squalor. In this unusual rare blend, urban features and rural agrarian patterns are combined in a new form of settlement and one might call ‘garden cities.’



Although it is often not given much attention, urban agriculture is steadily increasing. The practice involves cultivating, processing and distributing food in and around a town or city. It also encompasses an array of activities including horticulture, aquaculture, animal husbandry and bee keeping.

a) What are the challenges facing major cities and towns **(2mks)**

.....
.....
.....

b) What does the mention of 70% by 2025 reveal? **(2mks)**

.....
.....
.....

c) What do we learn about urbanization in Africa from the passage **(2 mks)**

.....
.....
.....

d) Mention the reason for rural to urban migration **(2mks)**

.....
.....
.....

e) How are urban households easing the problems of food shortage? **(3 mks)**

.....
.....
.....

f) What is meant by the term ‘garden city?’ **(1mk)**

.....
.....
.....

g) In note form, list the influences of urbanization **(4 mks)**

.....
.....
.....

.....



- h) Urban populations accounted for only 29% of the world population (1 mks)
(Rewrite the statement adding a question tag)

.....
.....

- i) Explain the meaning of the following words as used in the passage (3 mks)

i) Illusion

.....
.....

ii) Pragmatic

.....
.....

iii) Squalor

.....
.....

QUESTION 2: THE COMPULSORY SET TEXT (25 MARKS)

Nora: (*jumping up and going to him*) oh, dear, nice Doctor Rank, I never meant that at all. But surely you can understand that being with Torvald is a little like being with Papa –

(*enter MAID from the hall*)

Maid: if you please, ma'am. (*Whispers and hands her a card*)

Nora: (*glancing at the card*) oh! (*Puts it into her pocket*)

Rank: is there anything wrong?

Nora: No, no, not in the least. It is only something – it is my new dress –

Rank: what? Your dress is lying there.

Nora: Oh, yes, that one: but this is another. I ordered it. Torvald mustn't know about it –

Rank: Oho! Then was the great secret.

Nora: Of course. Just go in to him: he is sitting in the inner room. Keep him as long as –

Rank: Make our mind easy; I won't let him escape (*goes into HELMER'S room*)

Nora: (*to the MAID*) And he is standing waiting in the kitchen?

Maid: Yes; he came up the back stairs.

Nora: But didn't you tell him no one was in?

Maid: Yes, but it was no good.



Nora: He won't go away?

Maid: No; he says he won't until he has seen you, ma'am.

Nora: Well, let him come in – but quietly. Helen you mustn't say anything about it to anyone. It is a surprise for my husband.

Maid: Yes, ma'am, I quite understand. (*exit*)

Nora: This dreadful thing is going to happen! It will happen in spite of me! No, no, no, it can't happen – it shan't happen!

QUESTION 2 (25 marks)

a) Place this excerpt in its immediate context (3 mks)

.....
.....
.....
.....

b) Identify and illustrate the character trait of the following characters (4 mks)

i) Rank

.....
.....
.....

ii) Nora

.....
.....
.....

c) Who is in the kitchen and why has he come? (3mks)

.....
.....
.....

d) Identify and illustrate the dominant theme in the excerpt. (2mks)

.....
.....
.....



e) “..... being with Torvald is a little like being with papa” what does Nora mean by this statement?

(2mks)

.....
.....

f) Explain an incidence of dramatic irony from the excerpt.

(2mks)

.....
.....
.....

g) Why is Nora quick to usher Dr. Rank out of the room?

(2 mks)

.....
.....
.....

h) “This dreadful thing is going to happen. **“Rewrite in reported speech.**

(1mk)

.....

i) Explain the dreadful thing that Nora fears might happen?

(2 mks)

.....
.....
.....

j) Explain the meaning of the following expressions as used in the excerpt.

(3 mks)

i) Make your mind easy –

.....
.....

ii) I won't let him escape –

.....
.....

iii) It was no good –

.....
.....

iv) Dreadful -

.....
.....



QUESTION 3: ORAL LITERATURE (20marks)

Read the narrative below and then answer the questions that follow.

Once upon a time, all animals in the jungle were of the same plain colour but when they were invited by king lion for his son’s wedding, they decided to decorate themselves for the occasion. The tortoise was given the task of making the dye to be used. Though he was slow, he was the most intelligent.

The big day was fast approaching but the tortoise had only managed to make one big pot of black dye. He called a meeting and they all decided to use the available dye to make various patterns in their skins.

The leopard was allocated the job of painting the rest of the animals. The zebra was the first on queue followed by the giraffe, then the donkey and all the other animals were to follow. The giraffe and the zebra were painted and they looked very beautiful.

Then the donkey’s turn came but he was undecided on the pattern to choose. The leopard decided to paint him like a zebra and got down to work. He had a long line along the donkey’s spine from head towards the tail. On reaching the tail, the donkey started giggling. The leopard continued and the donkey jumped and threw him his hind legs saying the brush was tickling and he could not contain himself any longer.

He had thrown his hind legs so hard that he hit the pot containing the dye. The dye splattered all over the animals on the queue. The cheetah got speckles all over his body, the leopard got spotted and the crow who happened to be passing by with an urgent letter for the king hanging on its neck was splashed by the dye which covered him the whole body apart from the neck where the letter was. On seeing this, the hyena started laughing but got a large splotch on his mouth.

All the animals rushed to the stream to try and wash out the dye but it was already dried and had become permanent. Nobody could get off the spots, streaks, speckles and splotches. And that is how the donkey was responsible for the various patterns we see on animal’s bodies today.

a) Classify the narrative above.

(2mks)

.....
.....



b) Identify and illustrate any two social aspects of society from which this narrative is taken

(4 marks)

.....
.....
.....
.....
.....

c) Identify and illustrate any three features peculiar to oral narratives evident in this narrative.

(6mks)

.....
.....
.....
.....
.....
.....
.....
.....
.....
.....
.....
.....

d) Identify and illustrate any two character traits of the Leopard.

(4 mks)

.....
.....
.....
.....
.....
.....
.....
.....
.....
.....
.....

e) Who would be the target audience of such a narrative

(2mks)

.....



.....
.....
.....

f) If you were to collect this narrative from the field, what preparations would you make before the actual field work (2mks)

.....
.....
.....
.....

QUESTION 4: GRAMMAR (15 mks)

(a) Rewrite the following sentences according to the instructions given after each. Do not change the meaning.

1. The children welcomed the teachers.
(Begin with: The teachers)

.....
.....

2. John does not take Lunch. His sister does not take Lunch.
(Begin with: Neither)

.....
.....

3. Gatwiri asked, “Can we meet here tomorrow morning?”
(Rewrite in direct speech)

.....
.....

4. This novel is far better than the one I bought last week.
(Rewrite using the word ‘superior’)

.....
.....



5. It is not necessary to collect the garbage today.

(Rewrite being: You do not)

.....
.....

(b) Rewrite the following sentences to correct the errors.

1. Of the two books, the first is longest

.....
.....

2. The quarter of the three girls sleeps earlier.

.....
.....

3. I did not find any fellow colleagues in class when I arrived late.

.....
.....

(c) Supply the appropriate question tags in the blank spaces in the following sentences.

1. We needn't worry about tomorrow,

.....
.....

2. Let me have a taste,

.....
.....

3. They'll come early in the morning,

.....
.....

(d) Replace the underlined words with phrasal verbs formed from the words in brackets

1. Lucy asked Julius not to involve himself with her personal matters. (keep)

.....
.....

2. My mother accidentally met me along Jamhuri highway in the town (run)

.....
.....



.....
.....

(e) Use the words in bracket in their correct form to replace the underlined words.

1. The candidate was not popular amongst the electorate. (famous)

.....
.....

2. The vehicle that was moving very fast caused the accident. (speed)

.....
.....



KCSE 2021 PREDICTION

NAME.....

INDEX NO.....

SCHOOL.....

SIGN.....

DATE.....

101/3

ENGLISH

(CREATIVE COMPOSITION AND ESSAYS BASED ON SET TEXTS)

PAPER 3

TIME: 2 HOURS 30 MINUTES

INSTRUCTIONS TO THE CANDIDATES:-

- Answer **THREE QUESTIONS** in this paper
 - ❖ Question 1a or 1b (20mks)
 - ❖ Question 2 is compulsory (20 mks)
 - ❖ Question 3a or 3b or 3c (20mks)
- Where a candidate presents work on more than one optional text, only first one to appear will be marked.
- All answers to be written in the answers booklet provided.

For Examiners Use Only.

Question	Maximum	Candidate's score
1	20	
2	20	
3	20	
Total Score	60	



©2021 The Kenya National Examinations Council

KCSE 2021 Prediction SET 3



1. **Imaginative composition**

(a) Write a story ending with;

..... Truth be told, we strongly believe that he was innocent.

(20mks)

Or

(b) Write a story to illustrate the saying:

A fool and his money are soon parted

(20mks)

2. **The compulsory set test (20mks)**

“People who do bad deeds to others never go unrepaired”

Show the validity of this statement with reference to Henry Ole Kulet’s novel. Blossoms of the savannah”

3. **The option set – test (20mks)**

Answer only one of the following questions

Either

(a) *The short stories*

Chris Wanjala, memories we lost and other stories

Using Leila Aboud’s story “missing out” write an essay on how majoly’s stay in London alienates him from his people



Or

(b) Drama

David Mulwa, inheritance

“Pretenders are worse than murderers.” Write an essay to show the truthfulness of this statement basing your answer on the inheritance by David Mulwa.

Or

(c) The novel

John Steinbeck, the pearl

“The society has lost its moral values” using illustrations from The Pearl by John Steinbeck show the truth of this statement.

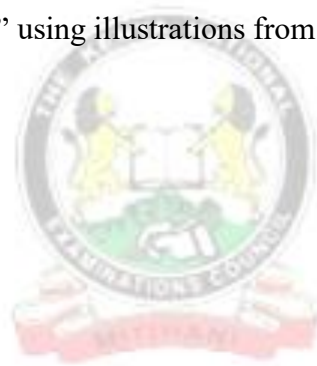

KCSE 2021 PREDICTION

NAME.....

INDEX NO.....

SCHOOL.....

SIGN.....

DATE.....

102/1

KISWAHILI

KARATASI YA 1

MUDA: SAA 1 $\frac{3}{4}$

MAAGIZO

- Jibu maswali mawili*
- Swali la kwanza ni la lazima*
- Kisha chagua swali lingine kutoka hayo matatu yaliyosalia*
- Kila insha isipungue maneno 400*
- Kila insha ina alama 20*



©2021 The Kenya National Examinations Council

KCSE 2021 Prediction SET 3



INSHA

SWALI LA LAZIMA

1. Kama mhariri wa gazeti, andika **tahariri** ukipongeza hatua ya serikali kupiga marufuku matumizi ya karatasi za sandarusi.

CHAGUA MOJA:

2. Eleza njia za kustawisha uchumi uliosambaratika katika eneogatuzi lako.
3. Pwagu hupata pwaguzi.
4. **Andika** insha itakayomalizikia kwa maneno haya.

“...Nilipokaa mezani kula chakula kitamu, nilikumbuka maisha magumu niliyoyapitia, nikatambua kuwa si rahisi kupata chakula kama hicho bila juhudi maishani”



For Marking Schemes Contact 0707-550-000 / 0705-525-657

.....

.....

.....

.....

.....

.....

.....

.....

.....

.....

.....

.....

.....

.....

.....

.....

.....

.....

.....

.....

.....

.....



©2021 The Kenya National Examinations Council

KCSE 2021 Prediction SET 3



.....
.....
.....
.....
.....
.....
.....
.....
.....
.....
.....
.....
.....
.....
.....
.....
.....
.....
.....
.....
.....
.....
.....
.....
.....



KCSE 2021 PREDICTION

NAME.....

INDEX NO.....

SCHOOL.....

SIGN.....

DATE.....

102/2

KISWAHILI

LUGHA

KARATASI YA 2

MUDA: SAA 2 ½

MAAGIZO

- Andika **jina lako** na **namba yako** katika nafasi ulizoachiwa hapo juu.
- Weka **sahihi yako** na **tarehe** ya mtihani katika nafasi ulizoachiwa
- Jibu maswali yote.
- Majibu yaandikwe katika nafasi zilizoachwa wazi katika kijitabu hiki cha maswali.

KWA MATUMIZI YA MTAHINI PEKEE.

SWALI	UPEO	ALAMA
1	15	
2	15	
3	40	
4	10	



1. UFAHAMU:

(ALAMA 15)

Soma kifungu kifuatacho kisha ujibu maswali:

Takwimu zilizothibitishwa zaonyesha kuwa kila sekunde nane mtu mmoja hufa duniani kutokana na utumiaji wa tumbako. Kwa siku basi, watu 10,800 hufa. Wengi wa wavuta sigara huanza katika umri kati ya miaka kumi na mitatu hadi kumi na tisa. Takwimu zaonyesha kuwa mtu akivuta sigara kwa zaidi ya miaka ishirini huupunguza umri wake kwa kati ya miaka 20 hadi 25 zaidi ya ambaye hajawahi kuvuta. Hii ni kwa kuwa tumbako ina zaidi ya kemikali 4,000 zinazodhuru afya.

Mojawapo ya madhara makuu zaidi yanayosababishwa na sigara ni saratani. Kunayo saratani ya ngozi – vidonda visivyopona huchubuka ngozini na baada ya muda hugeuka na kuwa kansa. Iri ya mapafu hutokea vifuko vya hewa vinapopasuka na hivyo kutatiza uvutaji wa oksijeni na utoaji wa kabondayoksaidi. Moshi pia husababisha madhara kwa njia ya kupitisha hewa, yaani umio, ambapo njia hii yaweza hata kuzibika hivyo kulazimu tundu kutobolewa kooni ili mgonjwa aweze kupumua. Kabla ya kufika kooni na mapafuni, moshi hupitia mdomoni. Saratani ya mdomo na ulimi basi hupatikana zaidi miongoni mwa wavuta sigara. Pia kidonda chochote, kwa mfano baada ya kung'olewa jino, huwa vigumu kupona kwa mvutaji sigara.

Kwa wanawake, kuna hatari ya kupatwa na iri ya fuko la uzazi. Madhara kwenye njia nzima ya uzazi huifanya iwe vigumu kwa wanawake wavuta sigara kuhimili. Ni rahisi pia kuzaa njiti. Mtoto wa mvutaji huzaliwa akiwa mwepesi zaidi ya kawaida. Hii husababishwa na kabonimonoksaidi kutoka kwa sigara inayomdhuru mtoto tumboni. Saratani hii husababisha hata kifo cha mtoto aliye tumboni. Wengine wazaliwapo huwa na hatari ya kupatwa na saratani zaidi ya waliozaliwa na akina mama wasiovuta sigara.

Aina zaidi za saratani zinazowakumba wavuta sigara ni kama vile saratani ya pua, ya tumbo, ya figo, ya kibofu cha mkojo, ya kongosho, ya njia ya kinyesi na hata saratani ya matiti inayowaathiri zaidi wanawake.

Shida za sigara sio saratani pekee; sigara husababisha shida za macho na masikio kwa kiasi kikubwa. Mboni ya jicho yaweza kufunikwa na utando, hali inayoweza kusababisha hata upofu. Macho yaweza kuwashwa na moshi mkali wa sigara au mishipa ya macho iathirike na kemikali zinazofika kwayo kupitia kwa mishipa mapafu yanapoathirika. Masikio nayo huathiriwa na uchafu wa tumbako unaoganda kwenye mishipa hadi sehemu za ndani za masikio. Damu hupunguza mwendo ufaao masikioni hivyo yanaugua. Moshi na



©2021 *The Kenya National Examinations Council*

KCSE 2021 Prediction SET 3



kemikali za tumbako pia hujeruhi sehemu za ndani na athari hii yaweza kuenea hadi ubongoni na kusababisha utando unaofunika ubongo. Hali hizi zaweza kusababisha uziwi.

Mifupa na meno huathirika pia. Mifupa huwa myepesi, hukosa nguvu na kuwa rahisi kuvunjika. Mvuta sigara akivunjika mfupa huchukua muda wa asilimia themanini (80%) kupona zaidi ya mtu asiyevuta. Meno nayo hutatizika katika ukuaji wake kutokana na kugandwa na moshi wenye kemikali. Hali hii husababisha harufu mbaya, uchafu pamoja na kuoza kwa meno.

Ngozi ya mvuta sigara hukaushwa na kemikali kwa sahabu uwezo wake wa kujirekebisha na kujilainisha hupunguzwa pakubwa. Hali hii husababisha ukavu unaoonekana pamoja na makunyanzi yanayomfanya mvuta sigara aonekane mzee zaidi ya umri wake. Vidole navyo vilevile hugandwa na kutu ya sigara, nazo kucha na vidole hugeuka rangi vikawa vya manjano, hudhurungi au maji ya kunde. Vidole pia hukaushwa na moto na kemikali ya sigara. Nywele za mvuta sigara pia huathirika kwa kuwa kemikali huipunguza kinga ya mwili hivyo mizizi ya nywele kukosa nguvu. Nywele za mvuta sigara zaweza kung'oka mapema.

Sigara husababisha magonjwa ya moyo na vidonda vya tumbo. Kwa moyo, sigara husababisha shinikizo la damu na hatimaye mshtuko wa moyo waweza kutokea na kusababisha hata kifo. Kwa tumbo, sigara hupunguza uwezo wa kinga zake wa kuikinga dhidi ya asidi zinazosaga chakula. Pia hupunguza uwezo wa mwili wa kujikinga dhidi ya vidonda vya tumboni. Vidonda vya tumbo vya mvuta sigara huwa vigumu kupona na, ni rahisi kutokea tena baada ya kupona.

Kwa mwanamume, mpigo wa damu kwenye sehemu za uzazi huathiriwa. Hali hii ikizidi husababisha hata upungufu wa nguvu ya mbegu kwenye shahawa. Hata ugumba waweza kutokea. Pia watoto wa mwanamke mvuta sigara waweza kuzaliwa wakiwa na kasoro. Mimba zingine zilizotungwa na wanawake wavuta sigara pia hutunguka. Na si hayo tu; madhara ya sigara ni mengi zaidi.

Maswali

a) Yape makala haya kichwa.

(alama 2)

.....

.....

.....



- b) Mbali na athari kwa uzazi kwa wanawake na wanaume na sura/umbo la binadamu, taja madhara mengine ya uvutaji sigara kwa binadamu. **(alama3)**

.....
.....
.....

- c) Kwa kurejelea kifungu onyesha kwamba sigara kwa wanawake hasa ni hatari mno. **(alama 4)**

.....
.....
.....

- (d) Je, ni kweli kuwa vifo vingi hutokea kwa sababu ya uvutaji sigara? Toa sababu. **(alama 2)**

.....
.....
.....

- (e) Eleza namna ambavyo uvutaji sigara huathiri sura ya mhusika. **(alama 3)**

.....
.....
.....

- (f) Eleza maana ya msamiati ufuatao kama ulivyotumiwa kwenye taarifa. **(alama 1)**

Gandwa _____



2. UFUPISHO:

(ALAMA 15)

Soma taarifa ifuatayo kisha ujibu maswali:

Biashara ya kimataifa ni muhimu sana katika ukuaji wa uchumi wa nchi yoyote ile. Nchi mbalimbali zimekuwa zikitegemeana kwa namna moja au nyingine. Kwa mfano, nchi ya Kenya imekuwa ikiuza maua na mboga katika nchi za ng'ambo na kupata fedha za kigeni ambazo hutumiwa humu nchini kuendeleza miradi mbalimbali ya maendeleo.

Biashara ya kimataifa huziwezesha nchi ambazo hazizalishi bidhaa na hata huduma mbalimbali kupata bidhaa hizo kutoka nchi nyingine zinazohusiana nayo katika biashara. Mathalan, Kenya ni nchi ambayo imekuwa ikitegemea kilimo lakini haijaendelea katika sekta ya viwanda. Kenya huagiza bidhaa kama vile vipuri vya magari na hata magari yenyewe kutoka nchi kama vile Japan. Nayo Kenya huuza mazao ya shambani kama vile pareto, chai na kahawa ng'ambo.

Kupitia kwa biashara ya kimataifa, nchi hupata masoko kwa bidhaa zake. Kwa vile biashara ya kimataifa huziwezesha nchi husika kuzalisha bidhaa mahususi ambazo hazitaigharimu nchi pesa nyingi kuzalisha, nchi hizo aghalabu huzalisha kiasi kikubwa cha bidhaa kuliko mahitaji yake ya nyumbani. Nchi basi hulazimika kutafuta masoko nje ya mipaka yake. Kwa njia hii uchumi wa nchi huendelea kuimarika.

Aidha, biashara ya kimataifa huwezesha nchi kupata huduma za kitaaluma ambazo hazipatikini katika nchi husika. Kuna nyanja za kiuchumi ambazo huhitaji wataalamu mahususi. Kwa mfano, katika sekta ya matibabu nchini humu tumepata kwamba kuna baadhi ya magonjwa ambayo yanahitaji matibabu maalumu. Wanaougua magonjwa haya huagiziwa madaktari kutoka ng'ambo au hata kupelekwa ng'ambo kwa uchunguzi na matibabu zaidi.

Biashara ya kimataifa hukuza ushirikiano wa kimataifa. Nyakati za majanga ya kimaumbile na hata mengine yanayosababishwa na kutowajibika kwa binadamu, nchi hupata usaidizi kutoka nchi za ng'ambo. Kwa mfano wakati wa mkasa wa bomu wa 1998, Kenya ilipata msaada wa kukabiliana na janga hili kutoka Israeli, Marekani na hata Ujerumani ambako baadhi ya waathiriwa wa mkasa huo walipelekwa kwa matibabu zaidi. Ushirikiano huu wa kimataifa huwezesha wananchi kutoka



©2021 The Kenya National Examinations Council

KCSE 2021 Prediction SET 3



For Marking Schemes Contact 0707-550-000 / 0705-525-657

nchi fulani kwenda kusomea na hata kufanya kazi katika nchi nyingine. Katika miaka ya hivi karibuni Wakenya wengi wamekuwa wakienda kusomea vyuo vikuu vya ng'ambo. Wengine wamediriki kupata kazi katika mashirika ya kimataifa katika nchi mbalimbali kama vile Afrika Kusini, Rwanda, Msumbiji na kadhalika.

Biashara ya kimataifa husaidia kukuza ushindani kati ya nchi husika. Ushindani huu ni hakikisho la uzalishaji wa bidhaa za thamani bora. Kila nchi itafanya juu chini kuzalisha bidhaa ambazo zinaweza kukubalika katika soko la kimataifa. Pia wananchi wa nchi husika hupata aina tofauti za bidhaa badala ya kutegemea aina moja tu ya bidhaa zinazozalishwa nchini mwao.

Biashara ya kimataifa huleta ushirikiano wa kisiasa na uelewano zaidi kati ya madola mbalimbali. Mathalan muungano wa nchi za Afrika Mashariki – Kenya, Uganda na Tanzania, hauchangii tu kuleta manufaa ya kiuchumi bali huleta ushirikiano zaidi wa kisiasa.

Ingawa biashara ya kimataifa ina natija, biashara hii huandamana na hasara mbalimbali. Biashara hii imesababisha kuwapo kwa masoko huru ambayo yameleta ushindani mkubwa kwa wafanyibiashara wadogo wa humu nchini. Baadhi ya wafanyibiashara wamelazimika kufunga biashara zao baada ya kufilisika. Ushuru mkubwa unaotowza baadhi ya bidhaa nchini huwafanya wananchi wengi kutofaidika kwa bidhaa na huduma kutoka nje. Aidha, kuna ucheleweshaji wa bidhaa zilizoagizwa. Bidhaa hizi mara nyingi huchukua muda kabla ya kutoka nchini, kwa hivyo wafanyibiashara wengi hulazimika kungojea kupata bidhaa hizi na kuwauzia wateja wao.

Vilevile, kutokana na biashara ya kimataifa, bidhaa duni huweza kupenyezwa katika mataifa yanayoendelea. Pia baadhi ya wafanyibiashara wa kimataifa huchukua fursa hii kulangua dawa mbalimbali za kulevya ambazo huwaathiri vijana wa nchi husika. Wengine huhusika katika vitendo vya kigaidi kama vile uchomaji wa majengo mbalimbali kwa bomu na mauaji ya ananchi wasio na hatia.

Ni kweli kuwa biashara ya kimataifa ina hasara zake. Hata hivyo mhimili mkubwa wa uchumi wa mataifa machanga.

(a) Kwa maneno yasiyozidi **themanini**, eleza umuhimu wa biashara ya kimataifa.

(alama 7)

©2021 *The Kenya National Examinations Council*

KCSE 2021 Prediction SET 3



Matayarisho

.....
.....
.....
.....
.....
.....
.....
.....
.....
.....
.....

Nakala safi

.....
.....
.....
.....
.....
.....
.....
.....
.....
.....
.....
.....

(b) Kwa maneno yasiyozidi **40**, eleza ujumbe wa aya tatu za mwisho.

(alama 6)

Matayarisho

.....
.....
.....
.....
.....



Nakala safi

3. MATUMIZI YA LUGHA

(a) Sahihisha sentensi: **(alama 2)**

(i) Mitume hiyo siyo ambayo tunaijua.

(ii) Wasikilizaji sasa wanaburudika na muziki kutoka idhaa la taifa hii.

(b) Ikanushe sentensi hii katika umoja. **(alama 2)**

Wasingecheza kiustadi wasingeshinda katika michezo ile.

(c) Tambulisha nyakati na hali katika sentensi: **(alama 2)**

(i) Wachezaji walikuwa wanafanya mazoezi.



(ii) Nkirote alipoingia alitukemea.

.....
.....

(d) Eleza maana za sentensi. **(alama 2)**

(i) Kwa nini wasililie hapa?

.....
.....

(ii) Kwa nini wasilie hapa?

.....
.....

(e) Toa mifano miwili miwili ya sauti zinazotamkiwa katika : **(alama 2)**

(i) ufizi

(ii) meno

(f) Andika udogo na ukubwa wa neno 'kidole'. **(alama 2)**

(i)..... (ii).....

(g) Tunga sentensi mbili tofauti kubainisha matumizi ya KWA. **(alama 2)**

(i).....

(ii).....

(h) Onyesha shamirisho kipozi na kitondo katika sentensi ifuatayo. **(alama 2)**

Msichana alimkaririra mgeni shairi.

(i)



(ii).....

(i) Tumia vitenzi hivi katika sentensi mojawoja katika jinsi ya kufanyiwa. **(alama 2)**

(i) nywa

.....

(ii) pa

.....

(j) Kistari kifupi (-) aghalabu hutumika kuendeleza sauti hasa katika vihisishi. Onyesha matumizi mengine matatu ya alama hii akifishi. **(alama 3)**

(i).....

(ii).....

(iii).....

(k) Tunga sentensi kubainisha tofauti kimaana kati ya vitawe: **(alama 2)**

(i)juha.....

(ii)jua.....

(l) Ziandike upya sentensi hizi kwa mujibu wa maagizo uliyopewa. **(alama 2)**

(i) Kiyondi aliukomelea mlango alipovisikia vishindo.

(Anza kwa :Mlango.....)

.....

.....

(ii) Mvua ilinyesha sana alasiri hiyo. Wachezaji walicheza mpira vizuri tu.

(Tumia ‘japo’)



.....
.....

(m) Tunga sentensi sahihi kubainisha matumizi ya KI kuonyesha: **(alama 4)**

(i) masharti

.....

(ii) ngeli

.....

(iii) kufanyika vitenzi viwili au zaidi wakati mmoja

.....

(iv) kielezi namna

.....

(n) Tambua hali na matumizi ya kisarufi ya neno lililopigwa mstari katika sentensi: **(alama 1)**

Mtu mzee anapaswa kuheshimiwa

.....

(o) Andika katika usemi halisi. **(alama 2)**

Mwalimu aliwaagiza wanafunzi warudi darasani, warejeele madaftari yao ya kumbukumbu na kuikosoa kazi hiyo.

.....
.....
.....
.....



(P) Andika katika umoja. **(alama 2)**

Tembe ambazo tulizimeza zilikuwa chungu.

.....

(q) Eleza maana za semi au nahau: **(alama 2)**

(i) kwenda mbweu

.....

.....

(ii) shika sikio

.....

.....

(r) Changanua sentensi ifuatayo kwa kielelezo cha jedwali **(alama 4)**

Kiatu kilichonunuliwa juzi kimerejeshwa dukani.

4. ISIMU - JAMII

(a) Eleza ukionyesha bayana tofauti baina ya lahaja na lafudhi. **(alama 4)**

.....

.....

.....

.....

.....

.....



(b) Taja sifa tatu tambulizi za lugha ya misimu

(alama 3)

.....
.....
.....
.....

(c) Orodhesha sifa kuu za sajili ya siasa.

(alama 3)

.....
.....
.....
.....
.....
.....
.....



KCSE 2021 PREDICTION

NAME.....

INDEX NO.....

SCHOOL.....

SIGN.....

DATE.....

102/3

KISWAHILI

KARATASI YA 3

FASIHI

MUDA: 2 ½

MAAGIZO

- Jibu maswali manne pekee. Swali la kwanza ni la lazima
- Maswali hayo mengine yachaguliwe kutoka sehemu zilizobaki
- Usijibu maswali **MAWILI** kutoka sehemu moja.

KWA MATUMIZI YA MTAHINI PEKEE

SWALI	UPEO	ALAMA
1	20	
2	20	
3	20	
4	20	
JUMLA	80	



©2021 The Kenya National Examinations Council

KCSE 2021 Prediction SET 3



SWALI LA LAZIMA

1.HADITHI FUPI

ALAMA 20

TUMBO LISILOSHIBA NA HADITHI NYINGINE :Alifa Chokocho Na Dumu

Kayanda

Mtihani wa Maisha

1. “..Acha nijiondokee duniani niwaachie wafanisi wafanikie.”
 - a) Eleza muktadha wa dondoo hili. Alama 4
 - b) Taja na ufafanue sifa tatu za msemaji. Alama 6
 - c) Eleza jinsi maisha ya msemaji yanavyoafiki anwani ya hadithi. Alama 10

2.RIWAYA YA CHOZI LA HERI : Assumpta Matei **ALAMA 20**

2. Eleza jinsi **maudhui ya ufisadi** yalivyoshughulikiwa katika riwaya ya Chozi la Heri. Alama 20
3. “...liandikwalo ndilo liwalo? Since when has man ever changed his destiny?”
 - a) Eleza muktadha wa dondoo hili. Alama 4
 - b) Bainisha mbinu tatu za kimtindo zinazojitokeza katika dondoo hili. Alama 6
 - c) Kwa kuzingatia hoja **kumi**, jadili jinsi ambavyo hali ya, “ **liandikwalo ndilo liwalo**”, inavyojitokeza katika Chozi la Heri. Alama 10.

3.TAMTHILIA YABKIGOGO : Pauline Kea **ALAMA 20**

4. “Utawala wa Majoka katika jimbo la Sagamoyo umejaa sumu ya nyoka.” Jadili. Alama 20
5. Eleza jinsi mbinu zifuatazo zilivyotumika katika tamthilia ya Kigogo
 - i) Kinaya Alama 6
 - ii) Majazi Alama 8
 - iii) Jazanda Alama 6



iv)

4.FASIHI SIMULIZI

ALAMA 20

6. a) Eleza **aina** tano za wahusika wa fasihi simulizi. Alama 10
- b) Eleza sifa za wahusika wa mighani. Alama 10
7. a) Eleza namna amabavyo hadhira wanahusishwa katika utambaji. Toa hoja nne. Alama 8
- b) Taja na ueleze sifa nne bainifu za hadithi. Alama 4
- c) Taja viungo vinavyopambanua muundo wa nyimbo katika jamii Alama 4
- d) Andika majukumu manne ya nyimbo katika jamii Alama 4

5.USHAIRI

ALAMA 20

8. Soma shairi lifuatalo kisha ujibu maswali.

Zitavuma,
Zitakoma,
Nitakwima,
Mti-mle.

Na muda nikisimama,
Nitatongoa nudhuma,
Kwa tenzi zilizo njema,
Nilisifu mti – mle.

Tazipanga tathlitha, tungo zilizo na hekima,
Za huba na thiatha, za kuburudi mitima,
Mashairi mabuthutha, musome mnaosoma.



Mti nishainukia, namea kuwa mzima,
Mizizi yadidimia, ardhini imeuma,
Nanena kitarbia, tungo zilizo adhama
Japo ni tungo za zama, mti-mle hutumia.

Zingavuma zitapusa, pepo kali zitakoma,
Dharuba kinitikisa, mti-mle huinama,
Huyumba nikaziya, matawi yakakingama,
Gharika ikishapisa, hurudi nikawa wima,
Na tungo za takhimisa, mti-mle huzipima.

Maswali

- (a) Shairi hili ni la kimapokeo. Toa sababu mbili **kuunga** kauli hii. (Alama.2)
- (b) Taja **bahari kuu** ya ushairi ambayo imetumiwa na mshairi. **Fafanua.** (Alama.2)
- (c) Fafanua dhamira ya mshairi. (Alama.2)
- (d) Kwa kutoa mifano bainisha tamathali mbili za usemi zilizotumika katika shairi hili. (Alama.2)
- (e) Eleza jinsi mshairi ametumia idhini ya ushairi katika utungo huu. (Alama.2)
- (f) Andika ubeti wa nne kwa lugha natharia. (Alama.4)
- (g) Mshairi anamaanisha nini anaposema zingavuma zitapusa, pepo kali zitakoma, (Alama.2)
- (h) Eleza toni ya shairi hili. (Alama.2)
- (i) Eleza maana ya msamiati ufuatao.
- i) Nitatongoa
- ii) Zitapusa. (Alama.2)

.....

.....

.....

.....



For Marking Schemes Contact 0707-550-000 / 0705-525-657

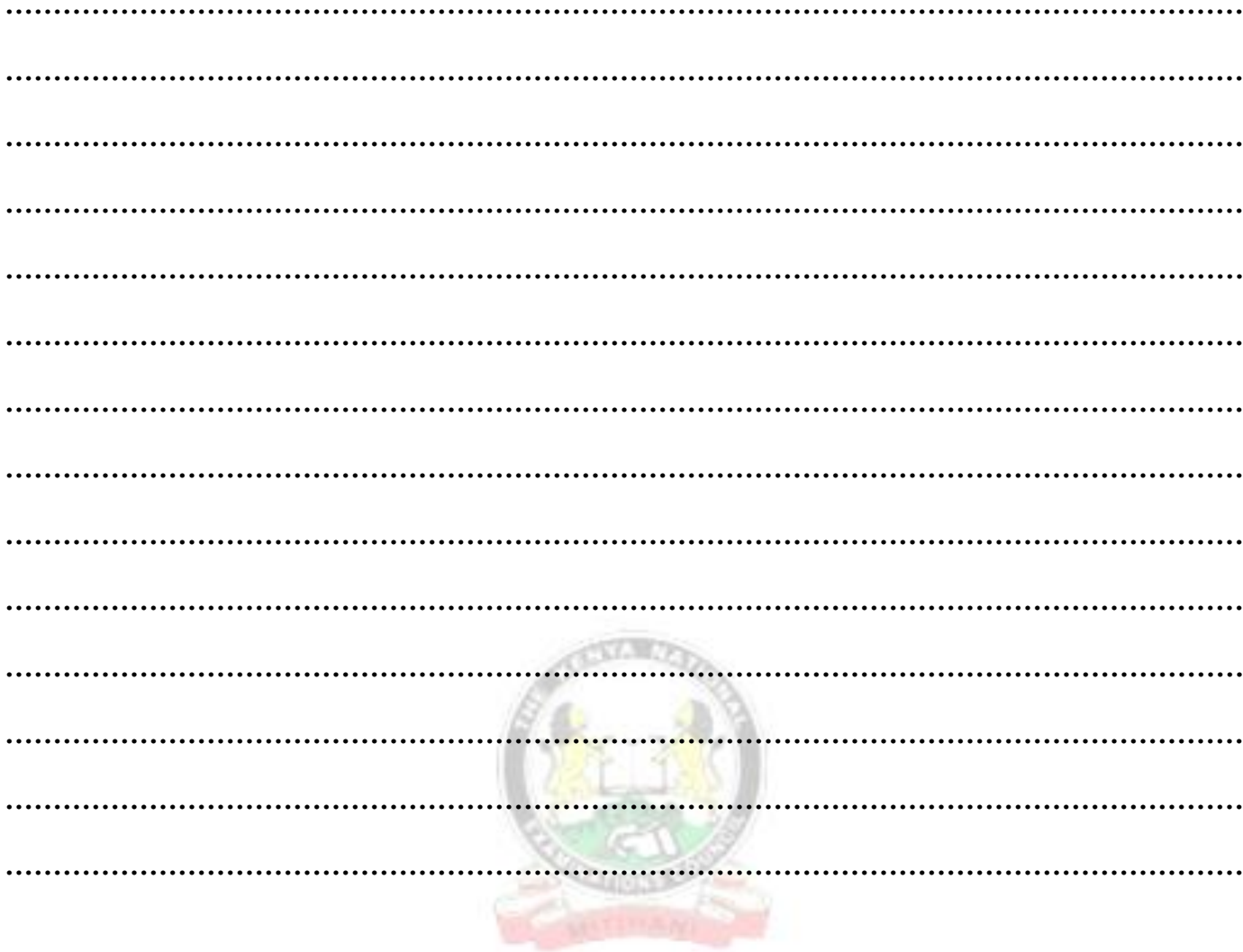

©2021 The Kenya National Examinations Council

KCSE 2021 Prediction SET 3



KCSE 2021 PREDICTION

NAME..... INDEX NO.....
SCHOOL..... SIGN.....
DATE.....

Kenya Certificate of Secondary Education (K.C.S.E.)

313/1

CHRISTIAN RELIGIOUS EDUCATION

PAPER 1

TIME: 2 ½ HOURS

INSTRUCTIONS TO CANDIDATES:

- *This paper consist of six questions*
- *Answer any five questions from this paper in the answer booklet provided.*

QUESTION	1	2	3	4	5	6	TOTAL
MARKS							

©2021 The Kenya National Examinations Council

KCSE 2021 Prediction SET 3



1. (a) State six similarities found in both biblical and traditional African views of creation (6mks)
(b) Outline the responsibilities given to human beings by God from the biblical creation stories in Gen 1 and 2 (8mks)
(c) Identify 6 ways in which people in traditional African communities take care of God's creation. (6mks)
2. (a) Describe how the Israelites broke the covenant they had made with God at Mt. Sinai Exodus 32: 1 – 30 (7mks)
(b) Identify seven ways in which God demonstrated his love for the Israelites during the exodus. (7mks)
(c) Give the lessons Christians learn from the incident in which the Israelites broke the covenant at Mt. Sinai (6mks)
3. (a) State the reasons for kingship in Israel. (6mks)
(b) Explain the significance of David as an ancestor of Jesus to Christians today. (8mks)
(c) State 6 lessons that Christians learn from the failures of King Saul. (6mks)
4. (a) Describe the socio- economic background of prophet Amos. (7mks)
(b) Explain the nature of God from the teachings of prophet Amos. (7mks)
(c) Identify six ways in which the church can promote justice in Kenya today. (6mks)
5. (a) Describe the personal life of prophet Jeremiah (8mks)
(b) Explain the circumstances that led the Israelites to be taken to exile in Babylon during the time of Prophet Jeremiah (7mks)
(c) State the relevance of prophet Jeremiah's suffering to Christians today. (5mks)

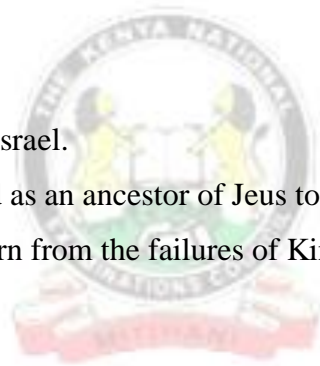

- 6. (a) Give 7 reasons why pregnancy before marriage is rare in traditional African communities. **(7mks)**
- (b) State the importance of bride wealth in traditional African communities **(5mks)**
- (c) Explain the socio-cultural changes that have taken place in traditional African communities in Kenya today. **(8mks)**

.....

.....

.....

.....

.....

.....

.....

.....

.....

.....

.....

.....

.....

.....

.....

.....

.....

.....

.....

.....

.....

.....

.....

.....

.....

.....



KCSE 2021 PREDICTION

NAME.....

INDEX NO.....

SCHOOL.....

SIGN.....

DATE.....

Kenya Certificate of Secondary Education (K.C.S.E.)

313/2

CHRISTIAN RELIGIOUS EDUCATION

PAPER 2

TIME: 2 ½ HOURS

INSTRUCTIONS TO CANDIDATES

- *This paper consist of six questions*
- *Answer any five questions in the answer booklet provided.*

QUESTION	1	2	3	4	5	6	TOTAL



©2021 The Kenya National Examinations Council

KCSE 2021 Prediction SET 3



MARKS							
--------------	--	--	--	--	--	--	--

1. (a) Explain the Jewish expectations concerning the messiah (7mks)
(b) State 7 similarities in the annunciation of the birth of John the Baptist and that of Jesus Christ. (7mks)
(c) Identify six lessons Christians learn from the annunciation of the birth of Jesus Christ (6mks)
2. (a) What was the importance of the transfiguration of Jesus? (8mks)
(b) Identify 6 occasions when Jesus prayed. (6mks)
(c) Give the lessons that Christians learn about Jesus from the transfiguration. (7mks)
3. (a) State 6 teachings of Jesus on the duties of discipleship (6mks)
(b) Narrate the parable of a friend at mid-night Luke 11 : 5 – 13 (7mks)
(c) What is the importance of prayer in a Christian life? (7mks)
4. (a) Identify 5 ways in which the work of the Holy Spirit was manifested on the day of Pentecost. (5mks)
(b) State the fruits of the holy spirit according to Gal 5 : 22) (8mks)
(c) State 7 reasons why some Christians find it difficult to help the sick. (7mks)
5. (a) Give 7 advantages of a monogamous marriage (7mks)
(b) Outline the importance of children in both Christianity and traditional African communities. (6mks)
(c) Identify ways through which Christians help to minimize conflicts between parents and their children in Kenya today (7mks)



- 6. (a)** Explain ways in which science and technology has improved human life. **(8mks)**
- (b)** Give 6 reasons why a Christian should donate blood. **(6mks)**
- (c)** List down reasons why tobacco is a health hazard **(6mks)**

.....

.....

.....

.....

.....

.....

.....

.....

.....

.....

.....

.....

.....

.....

.....

.....

.....

.....

.....

.....

.....

.....

.....

.....

.....

.....

.....

.....

.....

.....



KCSE 2021 PREDICTION

NAME.....

INDEX NO.....

SCHOOL.....

SIGN.....

DATE.....

Kenya Certificate of Secondary Education (K.C.S.E.)

312/1

GEOGRAPHY

PAPER 1

TIME: 2 ¾ HOURS

INSTRUCTIONS TO CANDIDATES:

- This paper consists of *two* sections: *A* and *B*
- Answer *all* the questions in section *A*
- Answer question *6* and *any two* questions from section *B*
- All answers *must* be written in the answer booklet provided



©2021 The Kenya National Examinations Council

KCSE 2021 Prediction SET 3



SECTION A

Answer all the questions in this section.

1. The diagram below represents part of the earth's crust which has been subjected to tension forces.

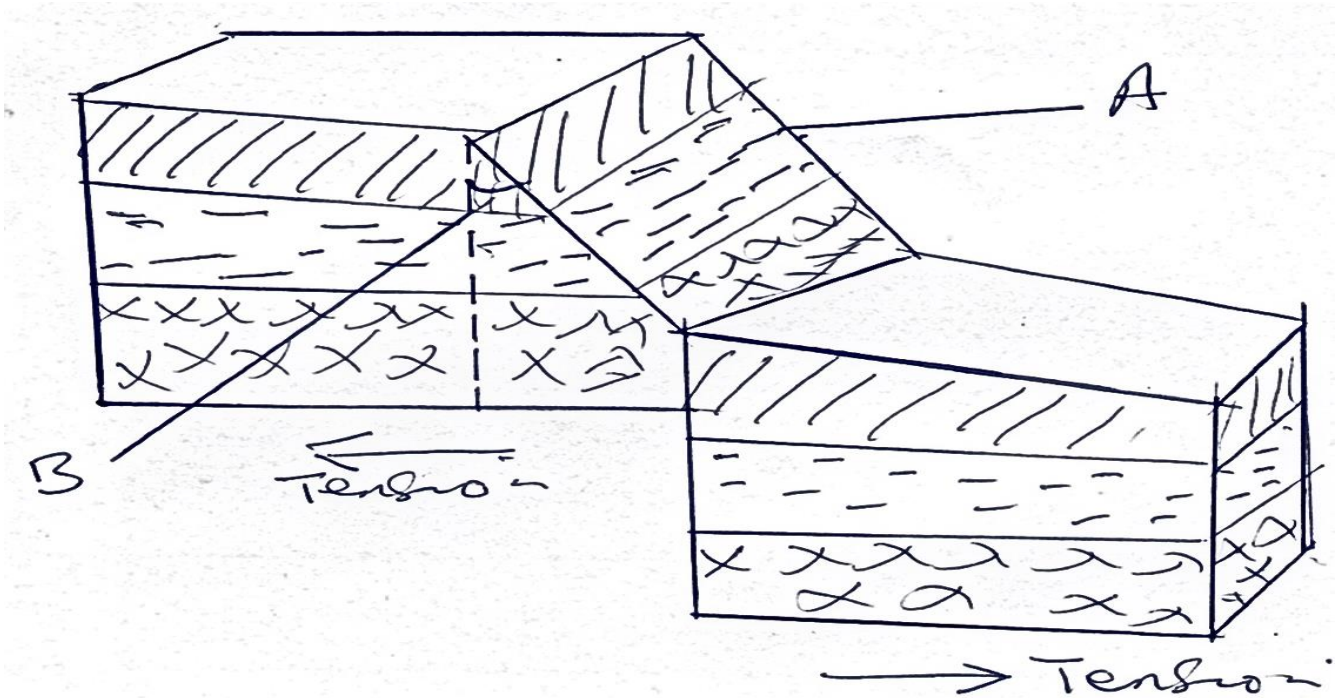

- a) i) Name the slope marked A. (1 mk)
ii) Name the angle marked B. (1 mk)
- b) State three ways in which faulting can influence drainage systems. (3mks)
2. a) Differentiate between longitudes and latitudes. (2mks)
b) If the local time in Nairobi on longitude 37°E is 10.00 a.m. What will the time be at Buchanan Liberian on longitude 10°W? (3 mks)
3. a) List four characteristics of desert soils. (3 mks)
b) Give two factors that contribute to soil leaching. (2 mks)



4. a) Give the two dates of equinoxes. (2 mks)
b) State three effects of the rotation of the earth. (3 mks)
5. a) Name the type of delta found at the mouth of:
i) River Nile (1 mk)
ii) River Omo (1 mk)
- b) State three conditions necessary for the formation of a delta. (3 mks)

SECTION B

Answer question 6 and any other two questions from this section.

6. Study the map of **Oyugis** 1:50,000 (sheet 130/1) provided and answer the following questions.
- a) i) State the magnetic declination when this map was drawn. (1 mk)
ii) Give the longitudinal extent of the area covered by the map. (1 mk)
- b) i) Name the feature found at the grid reference (786399). (2 mks)
ii) Identify two types of vegetation found in the area covered by the map. (2 mks)
- c) Citing evidence from the map, give four economic activities. (4 mks)
- d) Students from Tabaka in Oyugis carried out a field study on settlement activities in the area.
i) Identify two settlement patterns they found depicted in the area. (2 mks)
ii) Give two problems they were likely to encounter in their study. (2 mks)
- e) Draw a rectangle measuring 8cm by 6cm to represent area East of Eastings 90 and between Northings 36 and 39. On it indicate: (5 mks)
i) District boundary
ii) All weather road bound surface
iii) Seasonal swamp



7. a) Differentiate between vulcanicity and volcanicity. **(2 mks)**
- b) i) Other than lava plateau, list down four features resulting from extrusive volcanic activity. **(4 mks)**
- ii) Describe how lava plateau is formed. **(5 mks)**
- c) Explain four ways in which vulcanicity has influenced human activities in Kenya. **(8 mks)**
- d) You intend to carry out a field study of the landforms around your school.
- i) State three objectives of your study. **(3 mks)**
- ii) State three methods you would use to record the information you would collect. **(3 mks)**
8. a) Differentiate between weather and climate. **(2 mks)**
- b) Describe the climatic conditions experienced in the Kenya highlands. **(9 mks)**
- c) Explain how the following factors influence climate.
- i) Latitude **(2 mks)**
- ii) Altitude **(2 mks)**
- iii) Aspect **(2 mks)**
- iv) Winds **(2 mks)**
- d) Explain three ways in which vegetation in the Nyika region of Kenya adapts to the climatic conditions experienced in the area. **(6 mks)**
9. a) Name three places in East Africa where glaciers are found. **(3 mks)**
- b) Describe how each of the following glacial features are formed.
- i) Arete **(4 mks)**
- ii) Pyramidal peak **(4mks)**



- iii) Hanging valleys (4 mks)
- c) Explain five benefits of glaciated landscape to man. (10 mks)
10. a) List three processes through which coasts are eroded. (3 mks)
- b) State two causes of submergence of coasts. (2 mks)
- c) Using well labeled diagrams, explain how each of the following features are formed.
- i) Spit (4 mks)
- ii) Blow hole (4 mks)
- d) Some students carried out field study on the coastal features found along the coast of Kenya.
- i) State three preparations they made for their study. (3 mks)
- ii) List three features formed as a result of coastal emergence that they are likely to have studied. (3 mks)
- e) Explain three ways in which features resulting from coastal emergence are of significance to Kenya. (6 mks)



KCSE 2021 PREDICTION

NAME.....

INDEX NO.....

SCHOOL.....

SIGN.....

DATE.....

Kenya Certificate of Secondary Education (K.C.S.E.)

312/2

GEOGRAPHY

PAPER 2

TIME: 2 ¾ HOURS

INSTRUCTIONS TO CANDIDATES:

- This paper consists of **two** sections: **A** and **B**
- Answer **all** the questions in section **A**
- Answer question **6** and **any two** questions from section **B**
- All answers **must** be written in the answer booklet provided



©2021 The Kenya National Examinations Council

KCSE 2021 Prediction SET 3



SECTION A (25 marks)

Answer all the questions in this section.

1.
 - a) Name two provinces in Canada where wheat is grown in large scales. (2 mks)
 - b) List three social factors that influence agriculture. (3mks)
 - c) State two factors that favour mechanization of wheat farming in Canada. (2 mks)

2.
 - a) Name two horticultural crops grown in Kenya. (2 mks)
 - b) State three reasons why horticulture is more developed in the Netherlands than in Kenya. (3 mks)

3.
 - a) State three reasons why marine fisheries in Kenya are underdeveloped. (3 mks)
 - b) State three ways through which fish farming contributes to the economy of Kenya. (3 mks)

4.
 - a) Name two conditions that are necessary for the formation of petroleum. (2 mks)
 - b) List three ways in which open cast mining affects the environment. (3 mks)

5. Apart from desertification, name two other environmental hazards experienced in Kenya. (2 mks)



SECTION B

Answer question 6 and any other two questions from this section.

6. The table below shows some of Kenya's imports and exports in 1987. Use it to answer question (a) and (b).

Imports in Tonnes		Exports in Tonnes	
Item	Weight	Item	Weight
Sugar	99,000	Coffee	316,000
Iron & Steel	300,000	Tea	159,000
Fertilizer	84,000	Maize	259,000
Coal	105,000	Soda ash	150,000
Wheat	125,000	cement	225,000
Total	713,000		1,109,000

- a) i) Using a radius of 4cm, draw a piechart to represent the data of imports shown by the table above. **(8 mks)**
- ii) State three advantages of using pie charts to represent statistical data. **(3 mks)**
- b) Explain why Kenya imports sugar and wheat yet she is a producer of the same commodities. **(6 mks)**
- c) Explain four factors that influence importation and exportation of goods into and out of Kenya. **(8 mks)**
7. a) Name three types of industries located in the Ruhr region of Germany other than iron and steel. **(3 mks)**
- b) Explain four factors which led to the growth of iron and steel industry in Ruhr region of Germany. **(8 mks)**
- c) Explain four ways which Kenya has benefited by assembling motor vehicles locally. **(8 mks)**
- d) Describe three problems that are experienced in Kenya as a result of industrial development. **(6mks)**



8. a) Name four sources of electric power other than water. (4 mks)
- b) List five factors that favour location of hydroelectric power plant. (5 mks)
- c) Explain five ways in which Kenya has benefited from the development of a seven forks hydroelectric power scheme. (10 mks)
- d) Explain three problems that Kenya face as a result of over dependence on petroleum. (6 mks)
9. a) State three physical conditions necessary for growing of sugarcane. (3 mks)
- b) Describe commercial production of sugarcane from:
- i) Land preparation to harvesting (6 mks)
- ii) Processing to the marketing of sugar (8 mks)
- c) Geography students from Igoji went for a field study at Mumias sugar factory.
- i) Identify two methods they used to collect data (2 mks)
- ii) Explain three problems they identified facing sugar-cane farmers in Kenya. (6 mks)
10. a) Distinguish between transport and communication. (2mks)
- b) Name three products transported by pipeline. (3 mks)
- c) Explain why there are few railway lines among African countries. (6 mks)
- d) Explain three ways in which Kenya has benefited from her international airports. (6 mks)
- e) Describe four problems facing transport and communication in Africa. (8 mks)



KCSE 2021 PREDICTION

NAME..... INDEX NO.....

SCHOOL..... SIGN.....

DATE.....

311/1

HISTORY & GOVERNMENT

PAPER 1

TIME: 2 ½ HOURS

INSTRUCTIONS TO THE CANDIDATES:-

- This paper consists of **three** sections; **A, B, & C**
- Answer **all** questions in section **A**, **three** questions in section **B** and any **two** questions in section **C**.
- Answers to all questions **must** be written in the separate sheets provided.
- Candidate should answer the questions in English.

FOR EXAMINER'S USE ONLY:

SECTION		QUESTIONS	CANDIDATE'S
A		1- 17	
B		18	
		19	
		20	
		21	
C		22	
		23	
		24	
		TOTAL	



SECTION A (25MARKS)

Answer all questions in this section

1. Name one archaeological site in Kenya outside the rift valley? (1 mk)
2. Give two ways in which the constitution of Kenya guarantees the rule of law? (1 mk)
3. State any two educational commissions set up in Kenya after independence? (2 mks)
4. Identify any two specific groups of people in Kenya recognised by the new constitution? (2 mks)
5. Give the main method used by anthropologists to gather their historical information? (1 mk)
6. State two ways in which the Kenyan constitution promotes national unity? (2 mks)
7. Mention one social responsibility of Kenyan citizen? (1 mk)
8. Name one category of the Kenya defence forces? (1 mk)
9. Define devolution in relation to the Kenyan government today? (1 mk)
10. What is the main function of the equalization fund? (1 mk)
11. What was the centre of political power in decentralised societies of pre-colonial Kenya? (1 mk)
12. Give two reasons why the colonial government provided technical education to Africans? (2 mks)
13. Give the main reason why early visitors from Arabia came to the Kenyan coast before 1500? (1 mk)
14. Name one Bantu community in Kenya whose ancestors settled on mount Elgon? (1 mk)
15. Give two reasons why Africans who lived in towns formed social welfare organization during the colonial period? (2 mks)
16. Name two occasions when the Kenya national anthem is sung? (2 mks)
17. Give two ways in which industrial revolution in Europe hastened the colonisation of Kenya in the 19th century? (2 mks)



SECTION B (45MARKS)

Answer any three questions in this section

18. (a) State three ways in which the government of Kenya facilitated the acquisition of land for Africans after 1963? (3 mks)
- (b) Explain six challenges facing the agricultural sector in Kenya today? (12 mks)
19. (a) Identify three grade for elders among the Akamba? (3 mks)
- (b) Describe the political organisation of the Agikuyu in pre-colonial period? (12 mks)
20. (a) Give five methods used by colonial government to discourage the activities of the Mau Mau Movement? (5 mks)
- (b) Explain five roles of women in Kenya during the struggle for independence in Kenya?(10 mks)
21. (a) What factors led to the development of multi-party democracy in Kenya in the early 1990s? (3mks)
- (b) Explain how the existence of many political parties has promoted democracy in Kenya? (12mks)



SECTION C (30MARKS)

Answer any two questions in this section

22. (a) Identify three levels of conflicts? (3 mks)
(b) Explain six ways in which conflicts may have a negative effect in Kenya? (12 mks)
23. (a) Identify any three members of the county government assembly in Kenya? (3 mks)
(b) Explain six challenges facing the county government in Kenya? (12 mks)
24. (a) State three functions of the cabinet in Kenya? (3 mks)
(b) Explain six factors that may undermine the supremacy of Kenya's parliament. (12 mks)



For Marking Schemes Contact 0707-550-000 / 0705-525-657

A series of horizontal dotted lines for marking schemes, with a faint watermark of the Kenya National Examinations Council logo in the center.



©2021 The Kenya National Examinations Council

KCSE 2021 Prediction SET 3



For Marking Schemes Contact 0707-550-000 / 0705-525-657

.....

.....

.....

.....

.....

.....

.....

.....

.....

.....

.....

.....

.....

.....

.....

.....

.....

.....

.....

.....

.....

.....

.....



KCSE 2021 PREDICTION

NAME.....

INDEX NO.....

SCHOOL.....

SIGN.....

DATE.....

311/2

HISTORY & GOVERNMENT

PAPER 2

TIME: 2 ½ HOURS

INSTRUCTIONS TO THE CANDIDATES:-

- This paper consists of **three** sections; **A, B, & C**
- Answer **all** questions in section **A**, **three** questions in section **B** and any **two** questions in section **C**.
- Answers to all questions **must** be written in the separate sheets provided.
- Candidate should answer the questions in English.

FOR EXAMINER'S USE ONLY:

SECTION	QUESTIONS	CANDIDATE'S SCORE
A	1- 17	
B	18	
	19	
	20	
	21	
C	22	
	23	
	24	
	TOTAL	

©2021 The Kenya National Examinations Council

KCSE 2021 Prediction SET 3



SECTION A (25MARKS)

Answer all questions in this section

1. Identify **one** limitation that hinders use of electronic sources to get historical data. (1mark)
2. Give **two** major cultural developments by man towards the end of new Stone Age. (2marks)
3. State **two** remedies to perennial food shortages in Africa. (2marks)
4. What was the main commodity during the Trans-Atlantic trade? (1mark)
5. State **two** advantages of using aeroplanes over the ship as a means of transport. (2marks)
6. Identify **one** form of picture writing during the early civilization. (1mark)
7. State **two** uses of water as an early source of energy in industries. (2marks)
8. Identify **two** challenges faced by Athens as a ancient urban centre. (2marks)
9. State **one** way through which trade contributed to the rise of Asante Empire during the 19th century. (1mark)
10. Identify **one** way through which Europeans maintained peace among themselves during partition of African. (1mark)
11. State **two** factors that facilitated application of indirect rule in the Northern Nigeria. (2marks)
12. State **one** reason why USA did not join the First World War until 1917. (1 mark)
13. Identify **two** demands made by Austria- Hungary against Serbia following the assassination of arch Duke Ferdinand. (2 marks)
14. Give **one** countries in which cold war broke into real war. (1 mark)
15. Name the principal judicial organ of the United Nations Organization. (1 mark)
16. State **two** provisions contained in the Arusha declaration document adopted by Tanzania in 1967. (2 marks)
17. Identify the highest organ of the new East African Community. (1 mark)

©2021 The Kenya National Examinations Council

KCSE 2021 Prediction SET 3



For Marking Schemes Contact 0707-550-000 / 0705-525-657



©2021 The Kenya National Examinations Council

KCSE 2021 Prediction SET 3



SECTION B (45MARKS)

Answer any three questions in this section

- 18.** (a) State five uses of the Acheulian tools. (5marks)
- (b) Describe the cultural and Economic practices of the early man during the Middle Stone Age Period. (10marks)
- 19.** (a) Give **five** methods used to acquire slaves from West Africa during the Trans-Atlantic trade.(5marks)
- (b) Explain **five** factors that led to the decline of the Trans-Atlantic trade. (10marks)
- 20.** (a) Give 3 causes of army mutiny in Democratic Republic of Congo in 1960. (3marks)
- (b) Explain political development in Tanzania since independence. (12marks)
- 21.** (a) State **five** ways used by nationalists in Ghana to fight for independence. (5marks)
- (b) Explain **five** factors that led to development of African nationalism in Ghana. (10marks)



SECTION C (30MARKS)

Answer any two questions in this section

- 22.** (a) State three reasons for the failure of Schlieffen plan during First World War. (3marks)
(b) Explain six reasons for the Allies Victory during Second World War. (12marks)
- 23.** (a) State three conditions that gave rise to the Non-Aligned movement. (3 marks)
(b) Explain six challenges of the Non-Aligned movement. (12marks)
- 24.** (a) Identify the groups of people who cannot vie for elections in Britain (3marks)
(b) How is the executive in the USA checked by other organs of government (12 marks)



KCSE 2021 PREDICTION

NAME.....

INDEX NO.....

SCHOOL.....

SIGN.....

DATE.....

443/1

AGRICULTURE

PAPER 1

TIME: 2 HOURS

INSTRUCTIONS TO CANDIDATES:

- Write your name and Index number and sign in the spaces provided above.
- Answer ALL the questions in section A and B in the spaces provided in this booklet.
- Answer any two questions in section C in the spaces provided after the last question.

For Examiner's Use Only:

SECTION	QUESTIONS	MAXIMUM SCORE	CANDIDATES SCORE
A	1 - 18	30	
B	19 - 22	20	
C	23 - 25	40	
	TOTAL	90	



SECTION A (30marks).

Answer all Questions in this section.

1. a) State four characteristics of extensive farming system. (2mks)

.....
.....
.....
.....
.....

- b) List two disadvantages of small scale farming. (2mks)

.....
.....
.....

2. Name two ways in which predators affect agricultural production. (1mk)

.....
.....
.....

3. List down four factors that influence formation of soil. (2mks)

.....
.....
.....
.....

4. State two farming practices that bring about minimum tillage. (1mk)

.....
.....
.....

5. Name the function of each of the following chemicals in water treatment.

- a) Alum (1mk)

.....
.....

- b) Soda ash (1mk)



.....
.....
6. State two importance of organic matter in the soil. (1mk)

.....
.....
7. State three reasons why green manure is not commonly used in the farms. (1 ½ mks)

.....
.....
8. State four uses of farm records. (2mks)

.....
.....
9. List three importance of phosphorous in crop growth. (1 ½ mks)

.....
.....
10. Name four significance of using seeds as planting materials. (2mks)

.....
.....
11. List two importance of tissue culture in propagating crops. (1mk)



12. State the difference between the following terms. **(2mks)**

a) Rogueing

.....
.....

b) Gapping

.....
.....

13. State four effects of applying too much nitrogenous fertilizer to crops. **(2mks)**

.....
.....
.....
.....

14. Name four disadvantages of communal land tenure system. **(2mks)**

.....
.....
.....
.....

15. State four precautions farmers should observe when using agro-chemical for their safety and for environmental safety. **(2mks)**

.....
.....
.....
.....
.....
.....



16. State three harmful effects of pests on crops. (1 ½ mks)

.....
.....
.....

17. State three qualities of a good manager in a farm setting. (1 ½ mks)

.....
.....
.....

18. State two factors that influence the demand of a commodity. (1mk)

.....
.....
.....

SECTION B (20 MARKS)

Answer all questions in this section.

19. Study the diagram below and answer the questions that follow

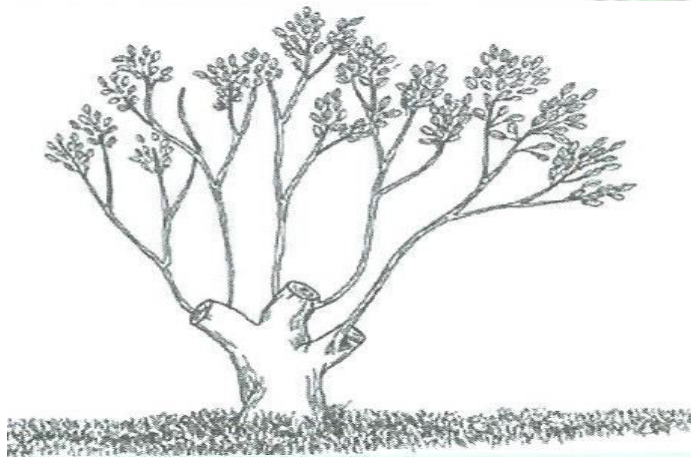

A

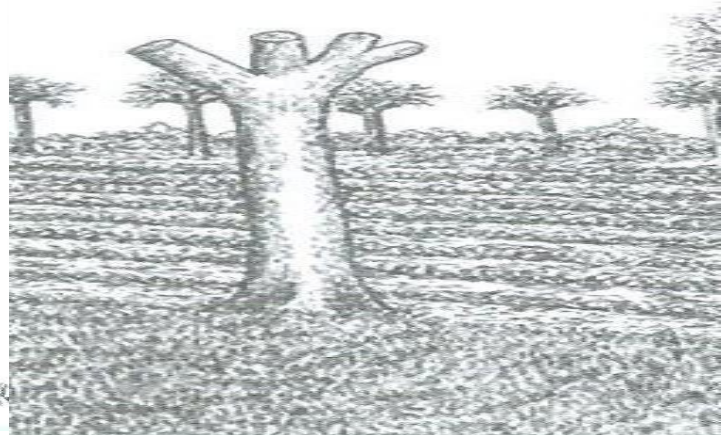

B

a) Identify the three harvesting methods shown in the diagrams above. (2mks)

.....
.....
.....



b) Name four sites for agroforestry trees in the farm.

(2mks)

20. The document below was obtained from one of the books of accounts in kimko's farm. Study the document and answer the questions that follow.

DAIRY CATTLE							
DR				CR			
Date	Particulars	Folio	Amount Sh cts.	Date 2003	Particulars	Folio	Amount Sh cts.
Feb 20 th	Bought 2 bags of dairy meal	1	18,000.00	Feb 10 th	Sold 2 heifers	1	12,000.00
Feb 30 th							

a) Identify the book from which the above document was obtained.

(1mk)

b) State four importance of keeping proper farm account records.

(2mks)



21. The diagram below shows pests that affect crops when in the field. Study the diagrams and answer the questions that follow.

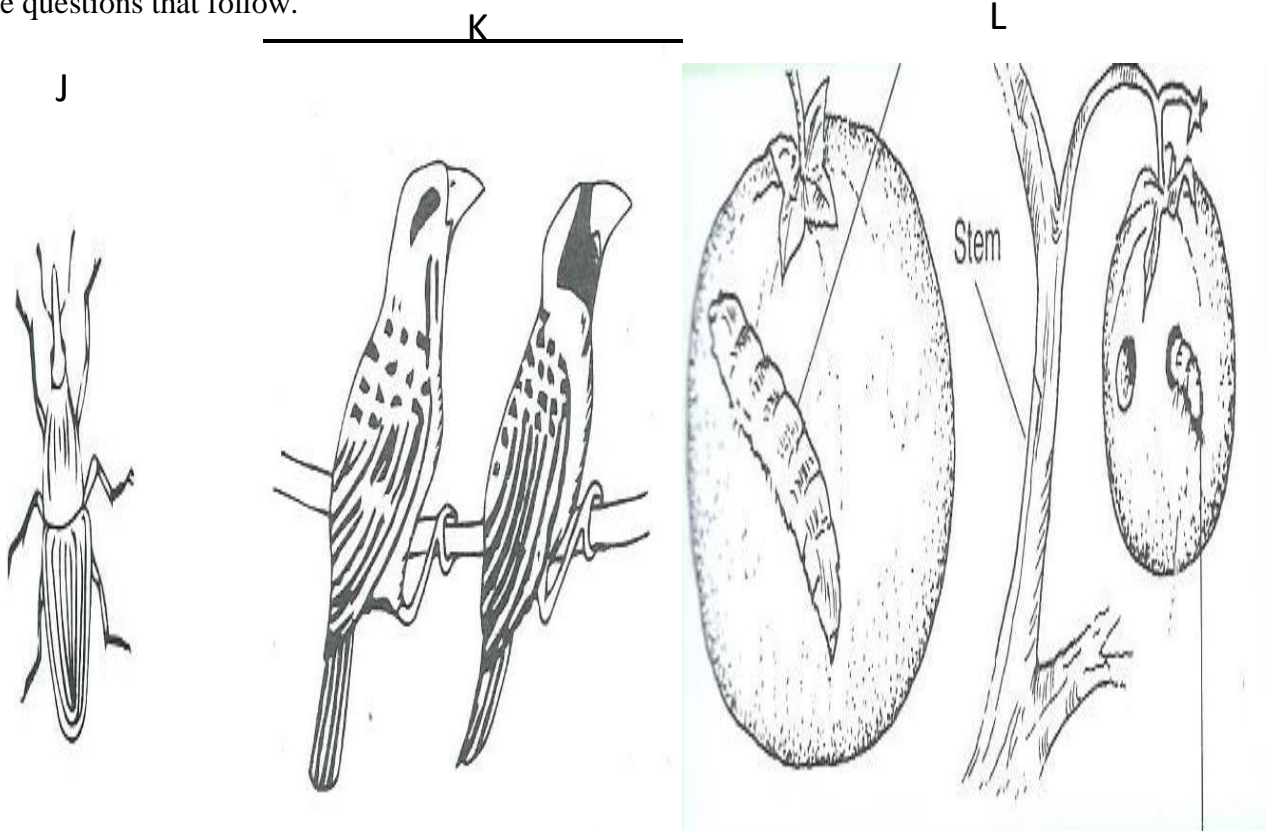

a) Identify the pest J, K and L.

(3mks)

.....

.....

.....

b) State two ways of controlling the pest labeled L above.

(2mks)

.....

.....

.....

c) State one crop attacked by the pest labeled J and K above.

(2mks)

.....

.....

22. The Following weeds were found growing on a maize farm by a form four student. Study the weeds and answer the questions that follow.



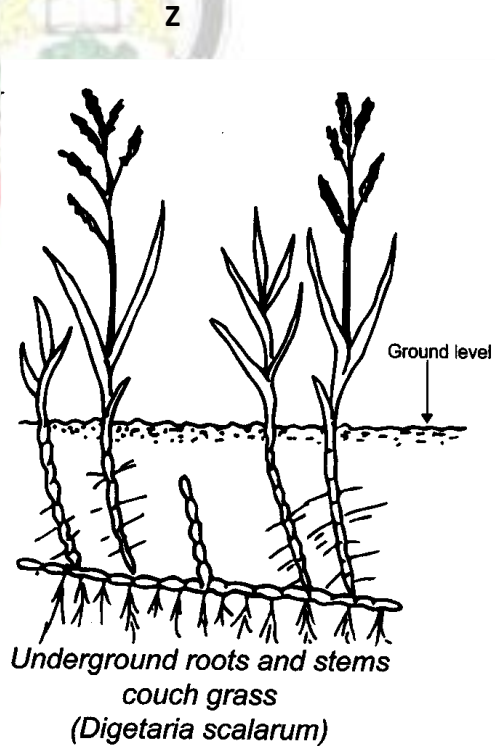

a) Name the weeds labeled X, Y and Z above.

(3mks)

.....

.....

.....

.....

b) State one reason that makes each of the following weeds difficult to control.

(2mks)

(i) X

.....

.....

(ii) Z

.....

.....

c) State one reason why the weed labeled M should not be allowed to grow in the farm. (1mk)

.....

.....

.....

.....

.....

.....



SECTION C (40 marks)

Answer only two questions in this section

23. a) Explain five cultural methods a farmer can use to control weeds. (10mks)
b) State and explain five factors considered when establishing nursery bed site. (10mks)
24. a) Describe five ways in which a farmer may adjust to uncertainty and risks in the farm. (10mks)
b) Explain five physical methods used to control crop pests in a crop land. (10mks)
25. a) State five types of information contained in a title deed. (5mks)
b) State five methods used to control soil and water pollution. (5mks)
c) State and explain five ways an entrepreneur can use to improve labour productivity in a farm. (10mks)



.....

.....

.....

.....

.....

.....

.....

.....

.....

.....

.....

.....

.....

.....

.....

.....

.....

.....

.....

.....

.....

.....

.....

.....



A series of 20 horizontal dotted lines for marking schemes.



For Marking Schemes Contact 0707-550-000 / 0705-525-657

A series of horizontal dotted lines for marking schemes, with a large, faint watermark of the Kenya National Examinations Council logo centered on the page.



©2021 The Kenya National Examinations Council

KCSE 2021 Prediction SET 3



For Marking Schemes Contact 0707-550-000 / 0705-525-657

.....
.....
.....
.....
.....
.....
.....
.....
.....
.....
.....
.....
.....
.....
.....
.....
.....
.....
.....
.....
.....
.....
.....
.....
.....
.....
.....
.....
.....
.....
.....
.....
.....
.....
.....
.....
.....
.....
.....



©2021 The Kenya National Examinations Council

KCSE 2021 Prediction SET 3



For Marking Schemes Contact 0707-550-000 / 0705-525-657



©2021 *The Kenya National Examinations Council*

KCSE 2021 Prediction SET 3



KCSE 2021 PREDICTION

NAME.....

INDEX NO.....

SCHOOL.....

SIGN.....

DATE.....

443/2

AGRICULTURE

PAPER 2

TIME: 2 HOURS

INSTRUCTIONS TO CANDIDATES:

- Write *your name* and *Index number* and *sign* in the spaces provided above.
- Answer *ALL* the questions in section *A* and *B* in the spaces provided in this booklet.
- Answer *any two* questions in section *C* in the spaces provided after the last question.

For Examiner's Use Only:

SECTION	QUESTIONS	MAXIMUM SCORE	CANDIDATES SCORE
A	1-18	30	
B	19-21	20	
C	22-24	40	
	TOTAL	90	



©2021 The Kenya National Examinations Council

KCSE 2021 Prediction SET 3



SECTION A (30MARKS)

Answer all the questions in this section.

1. State two reasons of using farm tools and equipment in the farm. (2mks)
.....
.....
.....
2. State three reasons that would make a farmer opt to rear indigenous cattle breeds instead of exotic cattle breeds. (1 ½ mks)
.....
.....
.....
3. State three characteristics of Bacterian type of camel. (1 ½ mks)
.....
.....
.....
4. Name four factors that influence the pulse rate of an animal. (2mks)
.....
.....
.....
.....
5. State three signs of attack by endoparasites a farmer can observe. (1 ½ mks)
.....
.....
.....
6. State four factors that determine the amount of food given to an animal. (2mks)



.....

.....

.....

.....

.....

.....

7. Name three reasons that would make a farmer use a machakos dip instead of a plunge dip to control ticks. (1 ½ mks)

.....

.....

.....

8. State four factors considered when selecting construction materials. (2mks)

.....

.....

.....

.....

9. Name three methods a farmer can use when selecting livestock for breeding. (1 ½ mks)

.....

.....

.....

10. Mention three signs of heat in a doe. (1 ½ mks)

.....

.....

.....

11. Mention four reasons that would make a farmer carry out identification to his herd. (2mks)

.....

.....



.....
.....
.....
12. State two diseases that commonly affect bees in bee farming. (2mks)

.....
.....
.....
13. State four methods a farmer can use when preserving fish after harvesting. (2mks)

.....
.....
.....
14. State four factors that determine the choice of poultry rearing system that a farmer chooses to use. (2mks)

.....
.....
.....
15. State one significance of mobile calf pen in calf rearing. (1mk)

.....
.....
.....
16. State two disadvantages of a two stroke engine. (1mk)

.....
.....
.....
17. State two factors that could cause sudden stopping of a tractor engine. (1mk)



18. State four disadvantages of animal drawn implements over tractor drawn implements. (2mks)

.....

.....

.....

.....

.....

SECTION B (20MARKS)

Answer all questions in this section.

19. The diagram below shows a tractor drawn implement. Study it and answer the questions that follow.

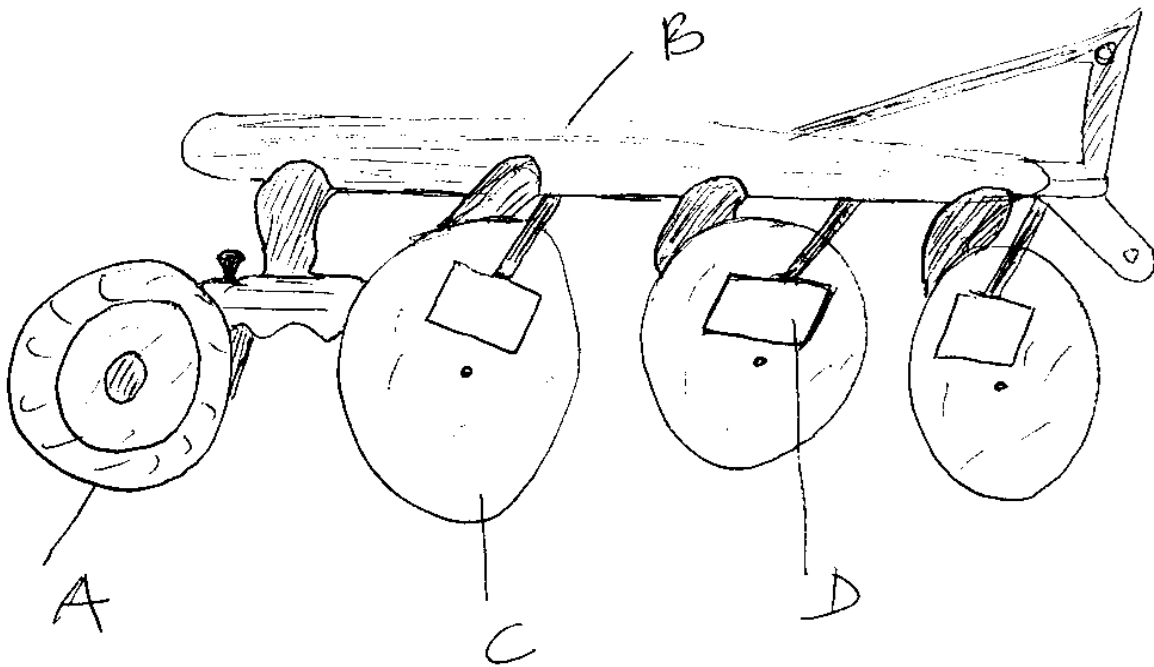

a) Name the parts A, B, C and D. (4mks)

(4mks)

.....

.....

.....

.....

b) State two advantages of using the above implement over mould-board plough. (2mks)

(2mks)



c) State the function of the parts labeled.

(2mks)

i) A

ii) D

20. The diagram below shows livestock parasites. Study the diagrams and answer the questions that follow.

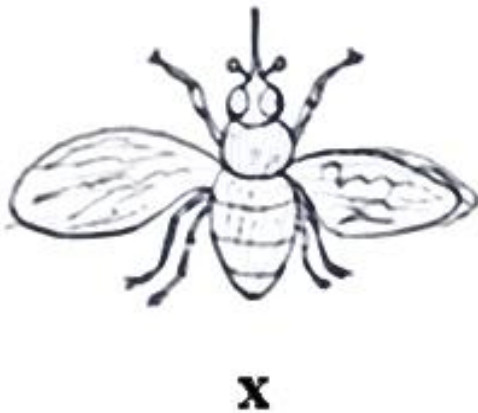

a) Identify the parasites X and Y above.

(2mks)

b) State two effects that are caused by the parasite labeled X on the animal's body.

(2mks)

c) Name one disease transmitted by parasite labeled X above. (1mk)

.....
.....

d) State three measures taken to control the parasite labeled Y above. (3mks)

.....
.....
.....

21. Study the diagram below and answer the questions that follow.



a) Identify the livestock equipment marked E above. (1mk)

.....
.....

b) State two reasons that make branding be discouraged as a method of livestock identification.

(1mk)

.....



SECTION C (40 MARKS)

Answer any two questions.

22. a) State five factors that predispose livestock to diseases. (10mks)
b) State and explain five factors a farmer will consider when siting beehives in the farm. (10mks)
23. a) Briefly state and explain five equipment a farmer will need when milking and state their uses. (10mks)
b) Explain five factors to consider when selecting a breeding stock. (10mks)
24. a) State and explain four materials collected by bees. (8mks)
b) State and explain the use of four equipments a honey harvester would require to have when harvesting honey. (8mks)
c) List four main reasons that make fish farming popular. (4mks)

.....

.....

.....

.....

.....

.....

.....

.....

.....

.....

.....

.....

.....

.....

.....

.....

.....

.....

.....

.....

.....

.....

.....



For Marking Schemes Contact 0707-550-000 / 0705-525-657

.....

.....

.....

.....

.....



©2021 *The Kenya National Examinations Council*

KCSE 2021 Prediction SET 3



KCSE 2021 PREDICTION

NAME.....

INDEX NO.....

SCHOOL.....

SIGN.....

DATE.....

Kenya Certificate of Secondary Education (K.C.S.E.)

565/1

BUSINESS STUDIES

PAPER 1

TIME: 2 HOURS

INSTRUCTIONS TO CANDIDATES:

- Write *your name and Admission Number* in the spaces provided.
- Answer *all* the questions in the spaces provided.

For Examiner's Use Only:

Question	Maximum score	Candidate's score
1-25	100 MARKS	



1). Outline four features of Basic wants

(4mks)

- a)
- b)
- c)
- d)

2). Name the type of warehouse associated with each of the statement given below

(4mks)

Statement	Type of warehouse
a). Good can be stored before payment of custom duties	
b). Individual can hire storage facilities	
c). goods are stored from several manufacturers	
d). Specialized goods are stored	

3). Highlight four characteristics of monopolistic competitive market

(4mks)

- a).
- b).
- c).
- d).

4). The following balances were extracted from The books of Gaitu Traders for the month ended on 31st march 2005,

	Sh.
Sales	420,000
Purchases	240,000
Motor van	300,000
Equipment	120,000
Debtors	80,000
Creditors	40,000
Expenses	160,000
Capital	440,000

Prepare trial balance for Gaitu Traders as at 31st march 2005.

(4mks)



5). Outline four benefits that Kenyan government from may get as a member of common market for Easter and Southern Africa (COMESA) **(4mks).**

- a).
- b).
- c).
- d).

6). Highlight Four circumstances under which a seller may offer after sales service to the buyer **(4mks)**

- a).
- b).
- c).
- d).

7). Highlight four indicators of economic growth that may be observed as a country progresses **(4mks)**

- a).
- b).
- c).
- d).

8). Outline four ways in which internal environment may contribute to success of a business **(4mks)**

- a).
- b).
- c).
- d).

9). Highlight four principles of a co-operative society **(4mks)**

- a).
- b).



- c)
- d).

10). Mobile phones have become a common means of communication in Kenya today. State four challenges that a trader may encounter when using mobile phones **(4mks)**

- a).
- b).
- c)
- d).

11). State four ways in which a youthful population may be useful to Kenyan economy **(4mks)**

- a).
- b).
- c)
- d).

12). State four characteristic of money

- a).
- b).
- c)
- d).



(4mks)

13). Outline four principles of public expenditure.

- a).
- b).
- c)
- d).

(4mks)



14). On 2nd November 2006 Kinoti received an invoice of Ksh. 12,000. Terms of payment were trade discount 5% and cash discount of 10% if payment is made within 30 days. Determine the amount paid if payment was made on 28th November 2006. **(4mks)**

15). Outline four characteristics of property insurance **(4mks)**

- a).
- b).
- c).
- d).



16). Highlight four factors that may cause supply curve to shift to the right **(4mks)**

- a).
- b).
- c).
- d).

17). List four features of a good filing system **(4mks)**

- a).
- b).
- c).
- d).



18).The following information relates to Khadija wholesalers. Capital at the end of the year 2016 was sh. 190,000, profit sh, 20,000, additional investment sh, 75,000 and drawings were sh.5000. Calculate Khadija wholesalers' initial capital.

19). Kenya has recently discovered crude oil in turkana. Outline four advantages of transporting the oil through pipeline **(4mks)**

- a).
- b).
- c).
- d).

20. The table shows some occupation in production .Indicate the level of production associated with each of the following occupations. **(4mks)**

Occupation	Level of production
a) mining	
b) oil refining	
c) insurance	
d) Teaching	

21). Highlight four benefits that would accrue to a firm located near other existing firms. **(4mks).**

- a).
- b).
- c).
- d).



22). State four roles of intermediaries in the chain of distribution. **(4mks)**

- a).
- b).
- c).
- d).

23). Outline four benefits of a business plan to an entrepreneur **(4mks)**

- a).
- b).
- c).
- d).

24). The following balances were extracted from the books of Kinja traders as at 31st December 2005.

	Sh.	
Current liabilities	150,000	
Net profit	50,000	
Total Assets	500,000	
2years Bank loan	100,000	
Calculate the rate of return on capital		(5mks)

25). Outline three monetary policy tools used by the central bank to control inflation. **(3mks)**

- a).
- b).
- c).



KCSE 2021 PREDICTION

NAME.....

INDEX NO.....

SCHOOL.....

SIGN.....

DATE.....

Kenya Certificate of Secondary Education (K.C.S.E.)

565/2

PAPER 2

BUSINESS STUDIES

TIME: 2 ½ HOURS

INSTRUCTIONS TO CANDIDATES:

- *This paper consists of six questions*
- *Answer any five questions in the answer booklet provided.*
- *All questions carry equal marks*



©2021 The Kenya National Examinations Council

KCSE 2021 Prediction SET 3



1. a). Explain five factors that may promote entrepreneurship in Kenya (10mks).
b). Explain five causes of balance of payments disequilibrium (10mks)
2. a). Explain five features that would be considered when establishing a warehouse for imported goods (10mks)
b). On 1st September 2015, Kakamega Traders had shs55, 000 in hand and shs 250,000 in Bank. During the month, the following transactions took place. (10mks)
- Sept: 2: cash sales were banked shs. 35,260.
3: Bought ribbons in cash shs. 4,500.
8: Paid Wangila creditor shs. 94, 000 by cheque,
In full settlement of his account after deducting 6% cash discount.
12: received a cheque for shs. 59,800 from macharia after allowing him cash discount of shs. 1,200
15: Paid salaries of shs 34,000 in cash.
25: withdrew shs. 50,000 from bank for office use.
28: Wanjiku a debtor paid her account of shs. 75,000 by cheque less 10% cash discount
30: Deposited all the cash into the bank except shs. 13,700.
- Required: Prepare Kakamega Traders 3 –column cash book and balance it off (10mks)
3. a). Explain five benefits that a private limited company may enjoy by changing to a public limited company (10mks)
b). Explain the functions of the following documents as used in home trade (10mks)
- i). Invoice
ii). Debit note
iii). Credit note
iv). Receipt
v). Statement of account



4. a). Explain any five sources of monopoly power in a monopoly (10mks)
b). Explain five benefits that Kenya enjoys by being a member of the African development Bank (10mks)

5. a). Outline any five principles of insurance (10mks)
b). The following trial balance relates to XYZ ltd.

XYZ limited
Trial Balance
As at 31st Dec. 2013.

Details	Dr Kshs	CR Kshs
Capital		800,000
Opening stock	200,000	
Purchases	680,000	
Returns	50,000	80,000
Discount	80,000	45,000
Carriage inwards	42,000	
Debtors and creditors	200,000	105,000
Sales		1,200,000
Motor vehicles	750,000	
Furniture and fittings	250,000	
Rent	50,000	60,000
Bank overdraft		42,000
Carriage outwards	30,000	

Additional information:

Closing stock was valued at shs. 80,000



Required:

Prepare XYZ limited Trading, profit and loss account (10mks).

6. a). Unemployment has been major problem that the Kenyan government has been trying to solve. Explain any five measures that the Kenyan government has taken to solve this problem (10mks).
- b) Explain any five sources of public finance (10mks)



For Marking Schemes Contact 0707-550-000 / 0705-525-657

A series of horizontal dotted lines providing a space for marking schemes.



©2021 The Kenya National Examinations Council

KCSE 2021 Prediction SET 3



For Marking Schemes Contact 0707-550-000 / 0705-525-657

A series of horizontal dotted lines for marking purposes.



©2021 *The Kenya National Examinations Council*

KCSE 2021 Prediction SET 3



A series of horizontal dotted lines for marking.



For Marking Schemes Contact 0707-550-000 / 0705-525-657

A series of horizontal dotted lines for writing, with a large, faint watermark of the Kenya National Examinations Council logo centered in the middle of the page.



©2021 The Kenya National Examinations Council

KCSE 2021 Prediction SET 3



KCSE 2021 PREDICTION

NAME.....

INDEX NO.....

SCHOOL.....

SIGN.....

DATE.....

441/1

HOMESCIENCE

PAPER 1

TIME: 2 ½ HOURS

INSTRUCTIONS TO CANDIDATES:

- Write your **name** and **index number** in the spaces provided.
- This paper consists of three section **A,B** and **C**
- Answer **all** the questions in section **A** and **B**
- Answer any **two** questions in section **C**.
- Answers should be written in the spaces provided in this booklet.
-

For Examiner's Use Only:

QUESTIONS	MAXIMUM SCORE	CANDIDATES SCORE
1-15	40	
16	20	
17	20	
18	20	
19	20	
Total	100	



©2021 The Kenya National Examinations Council

KCSE 2021 Prediction SET 3



SECTION A (40 marks)

Answer all the questions in this section.

1. Mention two methods of preserving fruits when in season. (2mrks)
.....
.....
2. List three natural means of ventilating a room. (3mrks)
.....
.....
.....
3. State two points to remember about clothing when caring for the sick at home. (2mrks)
.....
.....
4. Mention three examples of fans. (3mrks)
.....
.....
.....
5. Mention three points on how to ensure safety when storing paraffin. (3mrks)
.....
.....
.....
6. List three factors to consider when buying a gas cylinder. (3mrks)
.....
.....
.....
7. Give three reasons why the wall paper is becoming popular. (3mrks)
.....
.....



.....
.....
8. State two reasons for using floor coverings in a house. (2mrks)

.....
.....
9. List the stages involved in bottling as a method of preservation. (2 ½ mrks)

.....
.....
10. List two importance of blanching vegetables before preservation. (2mrks)

.....
.....
11. Define case goods and give an example. (½ mrk)

.....
.....
12. List four tertiary colours. (2mrks)

.....
.....
13. List four common dehydrated foods which are used as the main ingredients in a dish. (4mrks)



14. Mention three reasons for wrapping food before storing in the refrigerator. **(3mrks)**

.....

.....

.....

.....

15. Give three reasons for cooling foods before storing in a refrigerator. **(3mrks)**

.....

.....

.....

.....

SECTION B: COMPULSORY (20 MARKS)

Answer all the questions in this section.

16. You are planning to go for a picnic.

(a) Giving reasons outline the procedure you would use to thoroughly clean a synthetic bag. **(8mrks)**

.....

.....

.....

.....

.....

.....

.....

.....

.....

.....

.....

.....

.....

.....

.....

.....

.....

.....

.....

.....

.....



SECTION C (40 MARKS)

Answer any two questions in this section.

- 17. (a) State reasons why a consumer needs to be protected. (6mrks)
- (b) Mention six reasons that has popularized the use of convenience foods. (6mrks)
- (c) Discuss four problems related to breast feeding. (8mrks)

- 18. (a) List six qualities of a well-made collar. (6mrks)
- (b) Use the sketch of a skirt below to answer the questions that follow:

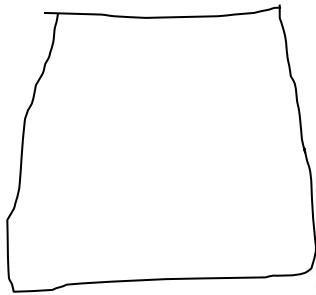

- (i) State six methods of disposing fullness in the skirt sketch shown above. (2mrks)
- (ii) Apart from the disposal of fullness symbols, indicate three pattern markings on the sketch above. (3mrks)
- (c) Explain four finishing processes carried out during laundry. (8mrks)

- 19. (a) Explain three causes of malnutrition when sick. (6mrks)
- (b) Explain six points on the importance of budgeting. (6mrks)
- (c) Mention eight points to look for when choosing a toy for a child. (8mrks)

.....

.....

.....

.....

.....

.....

.....

.....

.....



For Marking Schemes Contact 0707-550-000 / 0705-525-657

KCSE 2021 PREDICTION

NAME.....

INDEX NO.....

SCHOOL.....

SIGN.....

DATE.....

Kenya Certificate of Secondary Education (K.C.S.E.)

441/2

HOMESCIENCE

PAPER 2

TIME: 2 ½ HOURS

©2021 *The Kenya National Examinations Council*

KCSE 2021 Prediction SET 3



441/2 HOME SCIENCE

(CLOTHING & TEXTILE CONSTRUCTION)

A pattern of a child's dress is provided. You are advised to study the sketches, instructions and the layout well before you begin the test.

MATERIALS PROVIDED:

1. Pattern pieces for the dress:

A – Dress front

B – Dress back

C – Sleeve

D – Cuff

E – Pocket

F – Cuff interfacing

G – Sleeve opening binding

1. Plain light weight cotton fabric 70cm long by 90cm wide.

2. Cotton sewing thread to match the fabric.



THE TEST:

Using the materials provided cut out and make the LEFT HALF of the child's dress to show the following:

- The working of the shoulder dart.
- The preparation and attachment of the pocket.
- The joining of the shoulder seam using a neatened plain seam.
- The joining of the side seam using a neatened open seam.
- The making of the bound opening of the sleeve.
- The joining of the under arm seam using a French seam.
- The preparation and attachment of an interfaced cuff.



(h) The preparation and attachment of the sleeve, without trimming the seam allowance.

At the end of the examination, firmly sew onto your work, on a single fabric, a label bearing your name and index number. Remove the needles and pins from your work, and then fold your work neatly.

THE LAYOUT IS NOT DRAWN TO SCALE

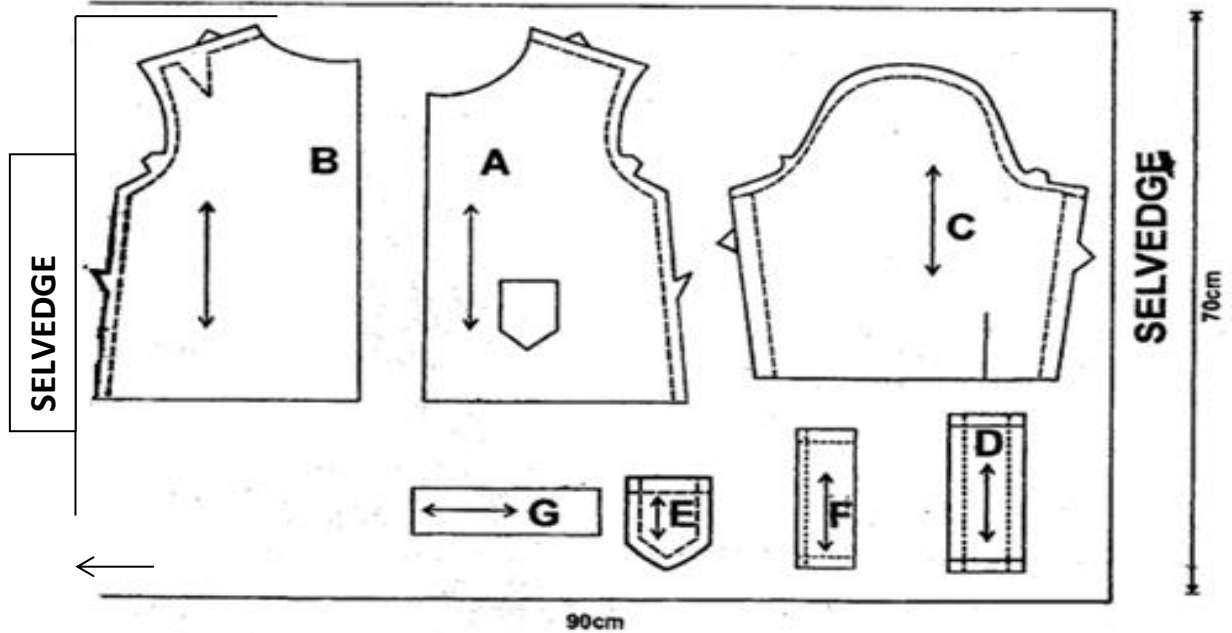

For Marking Schemes Contact 0707-550-000 / 0705-525-657



©2021 The Kenya National Examinations Council

KCSE 2021 Prediction SET 3



For Marking Schemes Contact 0707-550-000 / 0705-525-657

.....

.....

.....

.....

.....



©2021 *The Kenya National Examinations Council*

KCSE 2021 Prediction SET 3



KCSE 2021 PREDICTION

NAME.....

INDEX NO.....

SCHOOL.....

SIGN.....

DATE.....

Kenya Certificate of Secondary Education (K.C.S.E.)

441/3

HOMESCIENCE

PAPER 3

TIME: 1 ¾ hours

PLANNING SESSION: 30 MINUTES

PRACTICAL TEST SESSION: 1¼HOURS

©2021 *The Kenya National Examinations Council*

KCSE 2021 Prediction SET 3



INSTRUCTIONS TO CANDIDATES:

- Read the test carefully
- Text books and recipes may be used during the planning session as reference material. You will be expected to keep to your order of work during the practical session.
- You are allowed to take away only your reference materials at the end of the planning session. You are not allowed to bring additional notes to the practical session.

THE TEST

Your uncle is a manual labourer in a nearby quarry. Due to his busy work schedule in the quarry, you will be responsible for his meals. Therefore you will be expected to prepare, cook and serve him and yourself a one course meal to include a refreshing drink that you will take using ALL the ingredients provided below:

Ingredients:

- ❖ Chicken/beef/green grams
- ❖ Wheat flour/ green bananas/ Irish potatoes/ Nduma
- ❖ Kales/ cabbage
- ❖ Fat/ oil
- ❖ Onions
- ❖ Tomatoes
- ❖ Royco/ beef stock/ chicken stock
- ❖ Carrots
- ❖ Sugar
- ❖ Fruits in season



PLANNING SESSION:

Write the lists of the tasks to be performed on separate sheets of paper in duplicate copies using a carbon paper.

1. Identify the dishes and write down their recipes.
2. Write down the order of work.
3. Make a list of the food, materials and equipment needed for the task.

©2021 The Kenya National Examinations Council

KCSE 2021 Prediction SET 3



For Marking Schemes Contact 0707-550-000 / 0705-525-657

.....

.....

.....

.....

.....



©2021 *The Kenya National Examinations Council*

KCSE 2021 Prediction SET 3



KCSE 2021 PREDICTION

NAME..... INDEX NO.....

SCHOOL..... SIGN.....

DATE.....

451/1

COMPUTER STUDIES

PAPER ONE

TIME: 2½HRS

INSTRUCTIONS TO CANDIDATES

- ✓ This paper consists of two section A and B
- ✓ Answer all questions in section A (40 marks)
- ✓ Answer question 16 (**Compulsory**) and any other **THREE** questions in section B.

FOR EXAMINERS USE ONLY

SECTION	QUESTION	SCORE
A	1-15	
B	16	
	17	
	18	
	19	



SECTION A (40 MARKS)

Answer ALL the questions in this section

1. Define the following terms

(4mks)

i) Multiplexing

.....
.....
.....

ii) Baseband signal

.....
.....
.....

2. Explain the difference between digital signal and analog signal in data communication

(2mks)

.....
.....
.....
.....
.....

3. List down two types of computer viruses

(2mks)

.....
.....
.....

4. Below is a graphical representation of a section of a Microsoft words application window.

Use it to answer the question that follow.



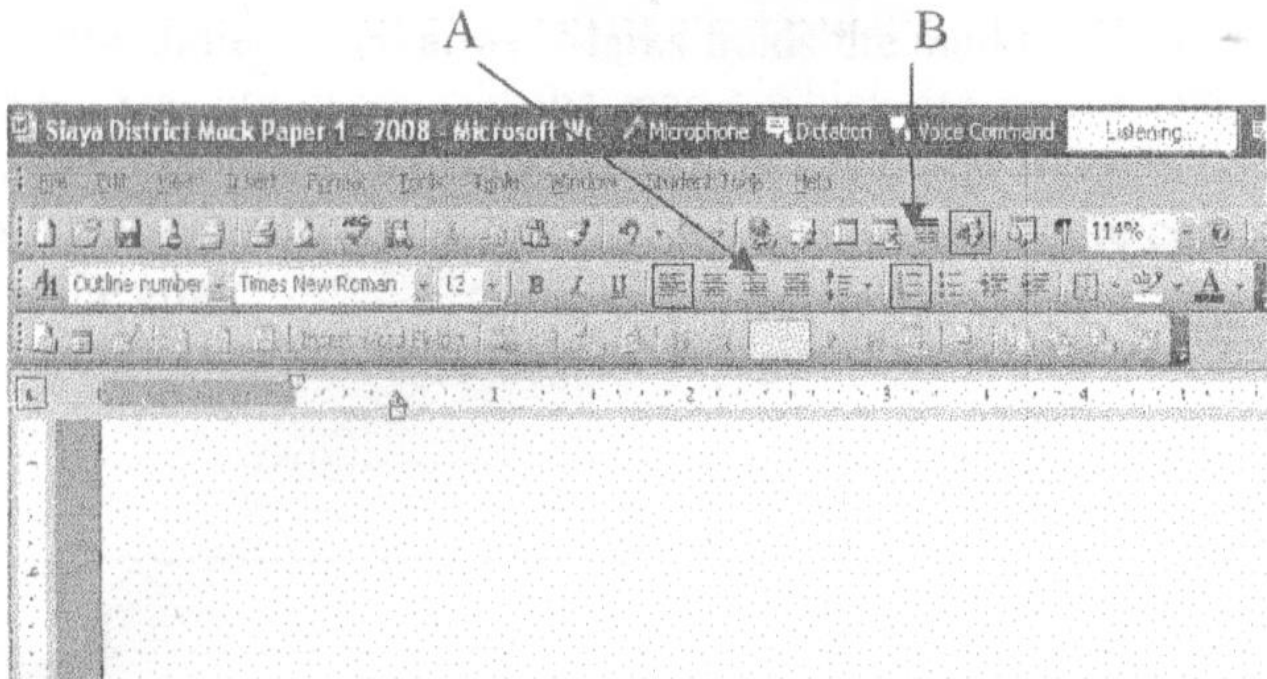

Give the uses of the icons labeled A and B

(2mks)

A

B

5. Define the following terms as used in disk management

i) Partitioning

(2mks)

.....
.....
.....

ii) Defragmentation

(2mks)

.....
.....
.....

6. State three ways in which your school librarian can use a computer

(3mks)

.....
.....
.....
.....



7. i) Write the acronym UPS in full? (1mk)

.....
.....

ii) Explain the uses of UPS? (1mk)

.....
.....
.....

8. a) Give two possible ways of fitting the document in one page (2mks)

.....
.....
.....
.....
.....
.....
.....

b) The shopkeeper one day switched on the computer and experienced a number of problems with windows operating system that he had installed. The problems included failure to load the operating system during the booting. After several trials of switching on the computer booting. It hand so often alongside abnormal restarting. State any two possible causes for the computer’s behavior. (2mks)

.....
.....
.....
.....
.....
.....
.....
.....
.....

9. Differentiate between real time processing and batch processing giving examples where each could be used. (4mks)

.....
.....



.....
.....
.....
.....
.....

10. In Kenya Tea Packers Company several people are employed as record clerks., typists and messenger. The company intends to introduce a computerized system in all the departments. Suggest three reasons that would make workers unhappy with the new system. **(3mks)**

.....
.....
.....

11. Give two advantages of an electronic spreadsheet over traditional analysis ledger sheet **(2mks)**

.....
.....
.....

12. Explain the following terms as used in information Technology with reference to software purchase:-

i) User friendliness **(1mk)**

.....
.....
.....

ii) Authenticity **(1mk)**

.....
.....
.....

13. While purchasing computers for his school the principal Musambweni high school decided to consult an expert. As a computer student advised him on four hard ware considerations

(2mks)

.....
.....



.....
.....
.....

14. Give the names of the following system flowchart symbols **(2mks)**



A

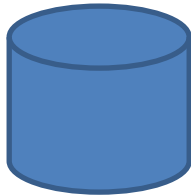

B

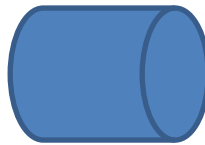

C

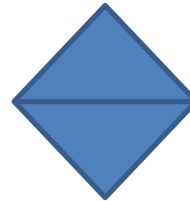

D

A

B

C

D

15. State any two features of a user friendly program **(2mks)**

.....
.....
.....

SECTION B (60 MARKS)

Answer question 16 and any other three questions from this section

16. a) State three qualities of a good pseudocode? **(3mks)**

.....
.....
.....
.....



b) i) State the 3 translators used in programming

(3mks)

.....
.....
.....
.....

ii) List two examples of;

i. Third generation languages

(1mk)

.....
.....
.....

ii. Object oriented languages

(1mk)

.....
.....
.....

c) Draw a flowchart that was used to come up with the following pseud code

(7mks)

Start

N=0

X=0

While n < 3

Repeat

X = X + 1

While x < 2

N = N +1

End while

Stop



For Marking Schemes Contact 0707-550-000 / 0705-525-657



©2021 The Kenya National Examinations Council

KCSE 2021 Prediction SET 3



17. a) The diagram below shows four common network topologies A, B, C and D.

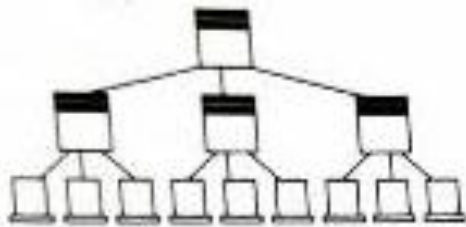

Topology A

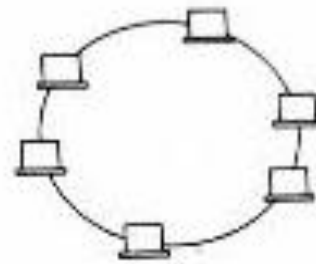

Topology B

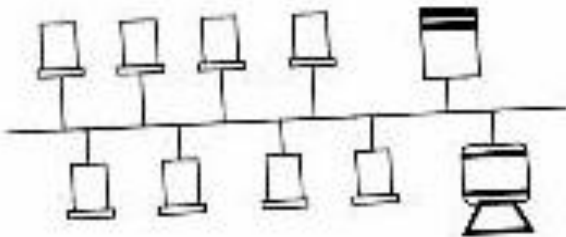

Topology C

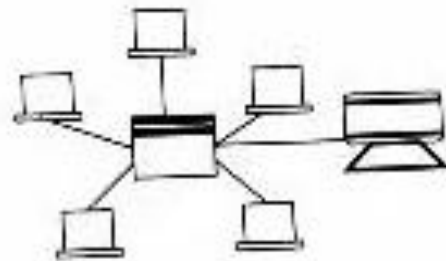

Topology D



i) Name the network topologies A, B, C and D

(4mks)

- A
- B
- C
- D

ii) Explain what happens if server X topology A fails

(1mk)



.....
.....
.....

iii) List two problems associated with network topology B **(2mks)**

.....
.....
.....

iv) List two disadvantages associated with network topology D **(2mks)**

.....
.....
.....

b) Differentiate between Internet and World Wide Web. **(2mks)**

.....
.....
.....

c) Convert the following binary number, 11001011.001 into decimal form. **(4mks)**

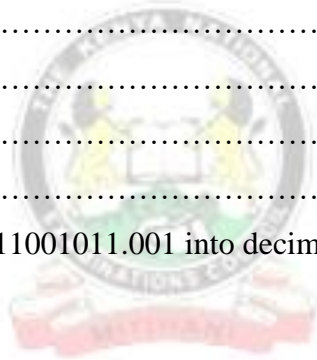

18. a) Human activity systems are said to be soft systems. Give the reasons why they are said to be so **(3mks)**

.....
.....
.....

b) What are hard information systems **(2mks)**



.....
.....
.....
.....

c) Discuss any five characteristics of a system (10mks)

.....
.....
.....
.....
.....
.....
.....
.....
.....
.....
.....
.....
.....
.....
.....
.....
.....
.....



19. a) One of the functions of an operating system is job scheduling. Explain what is meant by job scheduling.

(2mks)

.....
.....
.....
.....

b) List and explain three types of user interfaces. (6mks)

.....
.....
.....
.....



.....
.....
.....
.....

c) Describe the following categories of software (4mks)

i) Firmware

.....
.....
.....

ii) Proprietary software

.....
.....
.....

d) A new company ABC intends to go into business of desktop publishing. Advise the company on three computer hardware specification features to consider as a measure of enhancing performance. **(3mks)**

.....
.....
.....
.....

20. a) Briefly explain the following terms as used in spreadsheet (4mks)

i) Cell

.....
.....

ii) Range

.....
.....

iii) Value

.....

iv) Function

.....



b) List three paragraph formatting features of word processors

(3mks)

.....

.....

.....

c) Explain the difference between the printing of multiple pages and multiple copies

(2mks)

.....

.....

.....

d) Distinguish between a worksheet and a work book

(2mks)

.....

.....

.....

e) The following is an excel worksheet showing the performance of students in Tana class.

A	B	C	D Cat	E Cat	F	G	H
	Adam	Student name	1/50	2/50	Total / 40	Exam / 60	Total
1	4321	DollineMbesa	30	28	(a)	45	(b)
2	4333	SelinaMbugua	20	29		55	
3	4330	Winnie Wanjema	25	26		50	
4	4322	MagaretWambari	27	24		43	
5	4324	FaniNjuguna	28	24		42	
6		Maximum	(c)				
7		Minimum	(d)				
8		Average	(e)				
9							



For Marking Schemes Contact 0707-550-000 / 0705-525-657

Using the above worksheet write the following formula to calculate the values in cells labeled **(4mks)**

.....
.....
.....
.....
.....
.....
.....
.....
.....
.....
.....
.....
.....
.....
.....
.....
.....
.....
.....
.....
.....
.....
.....
.....
.....



©2021 The Kenya National Examinations Council

KCSE 2021 Prediction SET 3



KCSE 2021 PREDICTION

NAME.....

INDEX NO.....

SCHOOL.....

SIGN.....

DATE.....

451/1

COMPUTER STUDIES

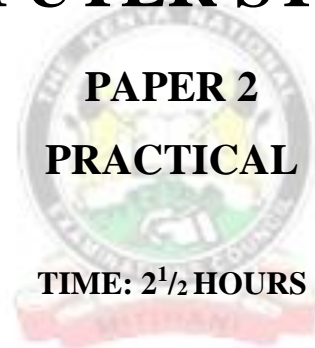

INSTRUCTIONS TO CANDIDATES

- ✓ Type your name and admission number at the top right hand corner of each printout.
- ✓ Write the name and version of the software used for each question attempted in the answer sheet.
- ✓ Passwords should not be used while saving in the diskettes.
- ✓ Answer all questions
- ✓ All questions carry equal marks
- ✓ All answers must be saved in your diskette. Make printouts of the answers on the answer sheets provided.
- ✓ Hand in all the printout and the diskette
- ✓ Candidates may be penalized for not following instruction given in this pager
- ✓ Arrange your printout and staple them together.



QUESTION 1

21. Table 1, table 2 and table 3 are extracts of records, kept in a carpentry shop. Use the information to answer the questions that follow;

CAPENTER _ID	CAPENTER NAME
CAP_001	JAMES
CAP_002	JOHN
CAP_003	ALEX
CAP_004	ISAAC
CAP_005	MAURICE

CUSTOMER _ID	CUSTOMER NAME
CUST_01	MARY K.
CUST_02	DIANA K.
CUST_03	ALEX N.
CUST_04	MARTHA K.
CUST_05	SARAH W.
CUST_06	JOHNSON G.

Carpenter Table

Customer Table

Order Table

CARPENTER _ID	CUSTOMER _ID	ORDER_NO	ITEM ORDERED	MONTH	AMOUNT
CAP_001	CUST_01	1721	Bench	January	18,000
CAP_002	CUST_02	1722	Coffee table	January	25,000
CAP_003	CUST_03	1723	Office table	January	10,000
CAP_004	CUST_04	1724	Single bed	January	18,000
CAP_005	CUST_05	1725	Arm chair	January	60,000
CAP_001	CUST_01	1726	Double bed	February	75,000
CAP_002	CUST_04	1727	Dining table	February	85,000
CAP_004	CUST_03	1728	Arm chair	February	60,000
CAP_001	CUST_02	1729	Double decker bed	February	72,000
CAP_002	CUST_06	1730	Kitchen table	February	82,000
CAP_004	CUST_02	1731	Bench	March	18,000
CAP_003	CUST_06	1732	bench	march	18,000

a) i) Using database application package, create a database file named;

©2021 The Kenya National Examinations Council

KCSE 2021 Prediction SET 3



CARPENTER INFORMATION

(1mk)

- ii) Create three tables named **Carpenter Table**, **Customer Table** and **Order Table** that will be used to store the above data. (10mks)
- iii) Set the primary key for the tables (2mks)
- iv) Create relationship among the tables (2mks)
- b) i) Create a data entry form for each table (3mks)
- ii) Enter the data in **Carpenter Table**, **Customer Table** and **Order Table** respectively (11mks)
- c) i) Create a query named **individual income** to display the amount received from each customer every month. (4mks)
- ii) Create a database object that computes Total income for each month. Save the query as **Totalincomenomthly**. (6mks)
- d) Create a query named **loyalty** to compute the total number of orders made by each customer over the three months. (3mks)
- e) Create a report to display order details, save the report as Order report (4mks)
- f) Print the three tables and the report (4mks)

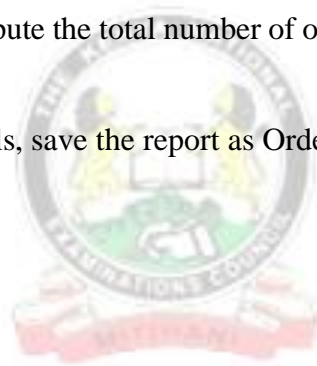

QUESTION 2

Use a spreadsheet to manipulate data in the table below.

Adm No	Name	Stream	Comp	Art	Bus	Eng	Mat	Student mean	Rank
C001	Barasa	H	56	45	36	56	26		
C002	Wangila	K	58	57	90	54	23		
C003	Wafula	H	48	56	54	45	25		
C004	Wanjala	K	78	95	78	46	24		
C005	Kerubo	H	49	86	68	35	52		
C006	Akinyi	K	56	45	25	63	54		
C007	Odhiambo	H	75	78	45	65	56		
C008	Okunyuku	K	89	69	65	53	51		
C009	Nekesa	H	69	58	45	54	52		
C010	Simiyu	H	85	46	78	52	53		
	TOTAL								
	TOTAL	FOR H							
	TOTAL	FOR K							

- a) Enter the data in all bordered worksheet and auto fit all column. Save the workbook as **mark 1** (15mks)
- b) Find the total marks for each subject (3mks)
- c) Find total for each subject per stream using a function (5mks)
- d) Find mean mark for each student using a function (5mks)
- e) Rank mean student in descending order using the mean (5mks)
- f) Create a well labeled column chart on a different sheet to show the mean mark of every student. Save the workbook as **mark 2.** (7mks)
- g) Using **mark1**, use subtotals to find the average mark for each subject per stream. Save the workbook as **mark 3** (7mks)
- h) Print **mark 1,mark 2** and the **chart**



For Marking Schemes Contact 0707-550-000 / 0705-525-657

A series of horizontal dotted lines for writing, with a large, faint watermark of the Kenya National Examinations Council logo centered in the middle of the page.



©2021 *The Kenya National Examinations Council*

KCSE 2021 Prediction SET 3



For Marking Schemes Contact 0707-550-000 / 0705-525-657

***THANK YOU FOR WORKING ON THIS
AWESOME DETAILED PREDICTION***

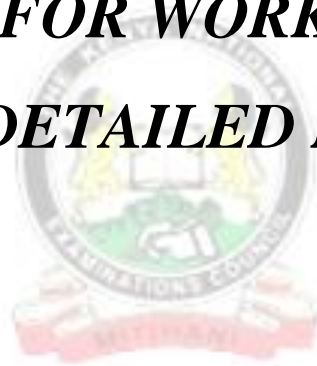

SUCCESS SUCCESS

©2021 The Kenya National Examinations Council

KCSE 2021 Prediction SET 3



For Marking Schemes Contact 0707-550-000 / 0705-525-657

For Marking Schemes Call/Text/Whatsapp

0705-525-657 / 0707-550-000



©2021 The Kenya National Examinations Council

KCSE 2021 Prediction SET 3

