

GEOGRAPHY PAPER 1 KCSE PAST PAPERS (1996-2016)

For marking schemes, call/Whatsapp-0746711892



'an investment of knowledge pays'

For marking schemes, prefer calling Mdm Mariam:0746711892

Other available resources are;

📌 well summarised primary and secondary

notes

📌 F1-F4 termly exams

📌 primary exams

📌 KCSE past papers

📌 KCPE past papers

📌 Mocks

📌 lesson plans

📌 schemes of work

Note: Exam questions are always free of charge

Marking scheme are not free

GEOGRAPHY
PAPER 1
1996
2 ³/₄ HOURS
Oct / Nov.

SECTION A

Answer all the questions in this section in the spaces provided.

1. a) List two features resulting from extrusive volcanic activity. (2mks)
 b) State four ways in which volcanicity has influenced human activities in Kenya. (4mks)
2. The block diagram below represents part of earth's crust which has been subjected to tensional forces.

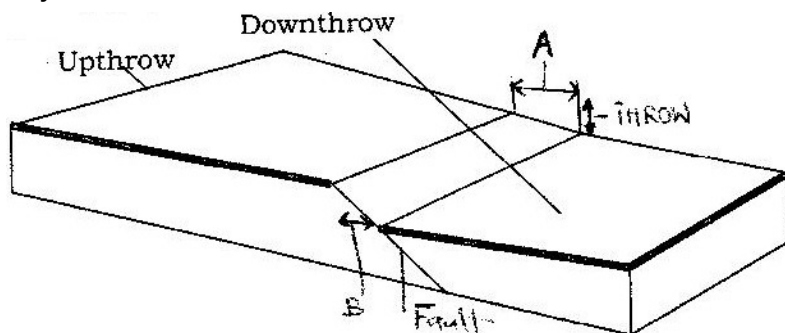

- a) Name (i) the slope marked A (1mk)
- b) State three ways in which faulting can influence drainage systems.(3mk)
3. a) What is isobar? (1mk)
 b) List four characteristics of modified Equatorial Climate (such as experienced in the lake Victoria Basin. (4mks)
4. a) If the local time in Nairobi at longitude 37° E is 10.00 a.m .
 What will the time be at /Buchanan in Liberia at longitude 10°W
 b) What is the effect of the international date line on time? (2mks)
5. a) Give three examples of mechanically formed sedimentary rocks(3mks)
 b) State two changes that occur in sedimentary rocks when they are subjected to intense heat and pressure.(2mks)

SECTION B

Answer question 1 and any other two questions from this section in your Booklet.

6. Study the map of Ithanga(1:50,000 sheet 135/4) provided and answer the following

questions.

- a) i) Give a six – figured grid reference for the trigonometrical station to the south – east of the area covered by the map (1mk)
- ii) What is the bearing of the school at kamwiendei village from the church at Riakanau?
- iii) Measure the length of the dry weather road (E 625), from the junction at karaba shops to where it ends at Riakanau village. Give your answer in kilometers (2mks)
- iv) Calculate the area of Tebere B in the northern part of the map. Give your answer in square kilometers (2mks)
- b) Student from one of the schools in the area covered by the map carried out a field study on the physical features and economical activities found in the area.
- i) Name two types of natural vegetation they are likely to have identified (2mks)
- ii) Citing evidence from the map, name three economic activities the students are likely to have identified during their study (3mks)
- iii) Citing evidence from map, name two methods the students are likely to have used to cross River Tana. (2mks)
- c) Describe the drainage of the area covered by the map. (4mks)
- d) Describe the distribution of settlements in the area covered by the map (3mks)
- e) Draw a rectangle 15cm by 10cm to represent the area west of Easting 20 and south of northing 00. On the rectangle, mark and name:
- i) The provincial boundary
- ii) Ithanga hills
- iii) The sisal plantation to the south west of the area (4mks)
7. a) i) What is river divide? (6mks)
- ii) Describe three ways by which a river transports its load (6mks)
- b) Describe the characteristics of a river in its old age (7mks)
- c) Describe each of the following drainage patterns
- i) Superimposed drainage pattern (3mks)
- ii) Centripetal drainage pattern (2mks)
- d) You have planned to carry out a study of a river in its youthful stage
- i) State **two** ways in which you would prepare for the study (2mks)
- ii) Name **two** feature you are likely to study (2mks)
- iii) List **two** problems you are likely to experience during the study (2mks)
8. a) List **four** processes through which costs are eroded (4mks)
- b) Using well-labeled diagram, explain how each of the following features is used formed.
- i) A spit (4mks)

- ii) A blow hole (2mks)
 - iii) An a toll (5mks)
 - c) Some student carried out a field study on the coastal features found along the coast of Kenya.
 - i) List **three** features formed as a result of coastal emergence that they are likely to have studied (3mks)
 - ii) State **three** methods tha student may have used to record their data (2mks)
 - iii) Describe **two** ways in which features resulting from coastal emergence are of significance of Kenya (2mks)
- 9.
- a) List
 - i) **Four** characteristics of desert soil (4mks)
 - ii) **Two** factors that contribute to soil leaching (2mks)
 - b) Explain how each of the following factors influences the formation of soil:
 - i) Parent rock (2mks)
 - ii) Living organisms (2mks)
 - iii) Topography (2mks)
 - c) Draw a well labelled profile of mature soil (5mks)
 - d) Explain four ways in which human activities contribute to soil erosion. (8mks)

SECTION A
 Answer all the questions in this section.

1. The diagram below shows the structure of the earth.

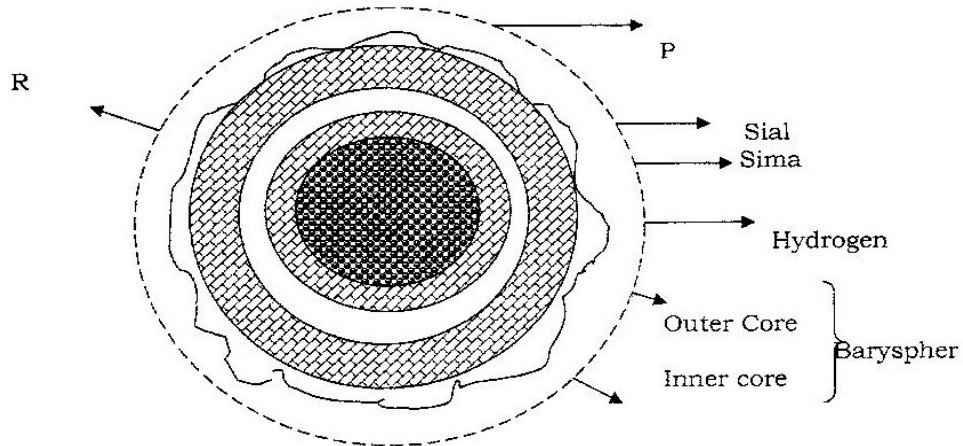

- a) Name the parts marked p, q and R (3mks)
 - b) Name the minerals that make up Sima (2mks)
2. a) Draw a well labeled diagram of the hydrological cycle (5mks)
- b) State two ways in which underground water may reach the surface of the earth (2mks)
3. The diagram below shows some features found in a Karst scenery

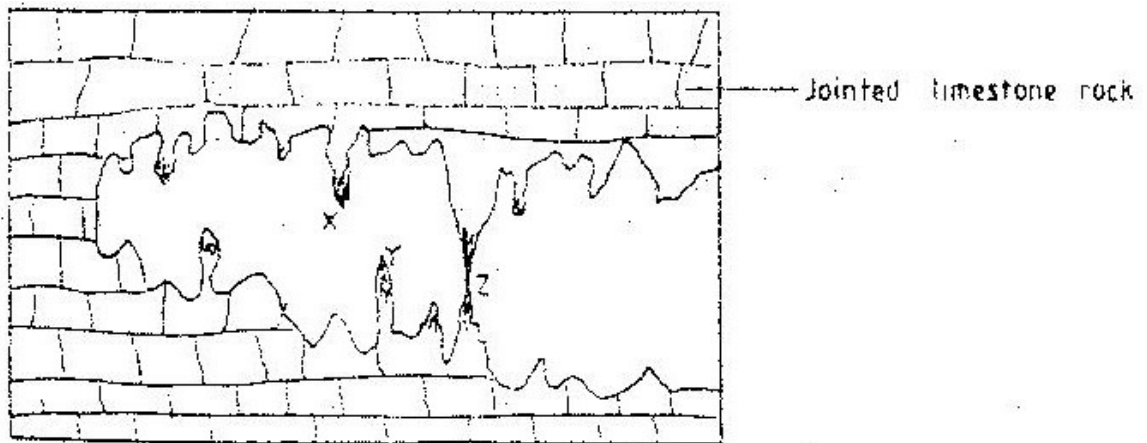

Name the features marked X,Y and z (3mks)

- 4. a) What is mass wasting? (1mks)

- b) State five factors which influence mass wasting. (5 mks)
5. a) Differentiate between weather and climate (2mks)
- b) The graph below shows climatic characteristics of a station in Kenya. Use it to answer the following questions.

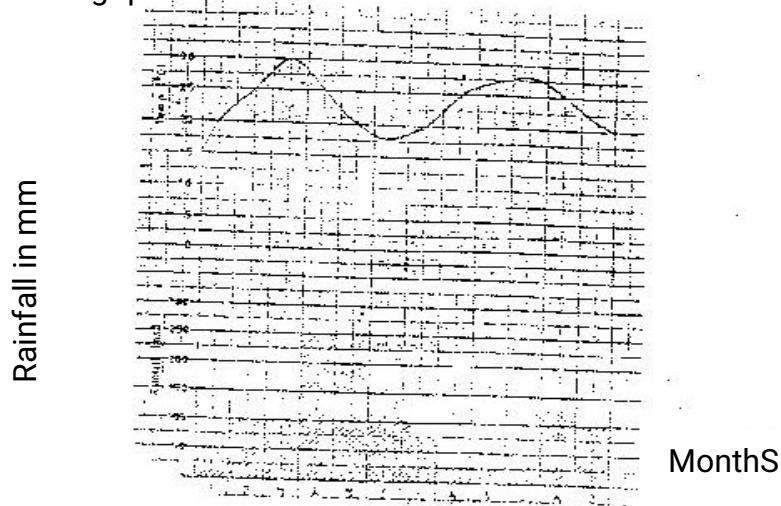

- i) Calculate the annual range temperature. (1mk)
- ii) Calculate the total amount of rainfall received at the station (1mk)

SECTION B

Answer questions 6 and any other two questions

6. Study the map provided (Kericho 1:50,000 sheet 117/4) and answer the following questions.
- a)(i) What feature is found at grid reference 691700? (2mks)
- (ii) Name two man-made features found in Grid square 6269. (2mks)
- (iii) Measure the length of the dry weather road E222 from the junction at Kipchimchim (grid reference 530640) to the junction with all weather road in the grid square 5863, Give your answer in kilometers (2mks)
- b) Using a scale of 1cm to represent 50m, draw a cross-section from grid reference 570670 to grid reference 620670 and name the following:
- (i) A river
- (ii) A motorable track
- (ii) Houses (6mks)
- c) Describe the drainage of the area to the northwest of the Kericho-Lumbwa all weather road. Cite examples of the drainage patterns identified. (6mks)
- d) Apart from the forests, name two other types of vegetation found in the area covered by the map. (2mks)
- e) Students of a school in Kericho used the map of Kericho to prepare for a field study on tea growing in the area.

- (i) Citing evidence from the map, state three conditions that favour tea growing in the area . (3mks)
- (ii) State three methods the students may have used to collect information during their study. (3mks)
7. a) Draw sketch map of Kenya on it, mark and name the
- (i) Lake Turkana (1mk)
- (ii) River Athi (1mk)
- (iii) Mount Kenya (1mk)
- (iv) The equator (1mk)
- b) Describe the climate conditions experienced in the Kenya highlands.
- c) Explain four ways in which vegetation in the Nyika region of Kenya has adapted to the climate conditions experienced in the area. (8mks)
- d) Explain how the presence of a cold ocean current influences the climate of the adjacent coastlands. (4mks)
8. a) With the aid of well labeled diagrams, describe the processes involved in the formation of a corrie lake. (8mks)
- b) Explain four ways in which a glaciated landscape is of significance to human activities. (8mks)
- c) Suppose students were to carry out a field study on glaciations on Mt.Kenya.
- (i) Give two reasons why they would need a route map (2mks)
- (ii) Name two types of moraines they are likely to study (2mks)
- (iii) State two problems they are likely to experience during the field study. (2mks)
9. a) Give three examples of chemically formed sedimentary rocks. (3mks)
- b) (i) State three conditions necessary for the growth of coral. (3mks)
- (ii) Describe how coral racks are formed. (4mks)
- c) Explain four ways in which rocks contribute to the economy of Kenya (8mks)
- d) Some students are planning to carry out a field study on rock weathering around their school.
- (i) List three secondary sources of information they are likely to use as they prepare for the field study. (3mks)
- (ii) a part from using secondary sources, state four other ways in which the students would prepare themselves for the field study.(4mks)

GEOGRAPHY
 PAPER 1
 1998
 2 ³/₄ HOURS
 Oct / Nov.

SECTION A

Answer all the questions in this section

1. The diagram below represents the earth on its axis. Use it to answer question (a)

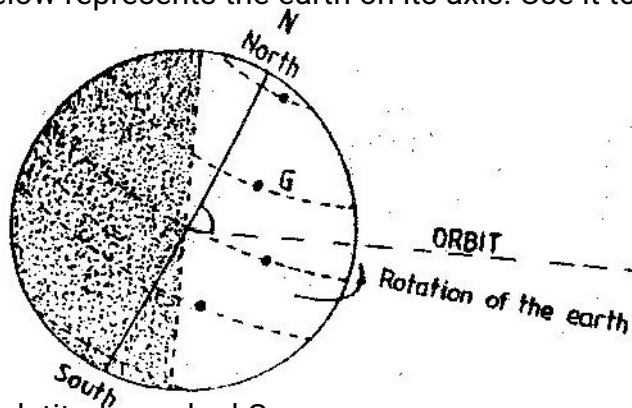

- (a) (i) Name the latitude marked G
 (ii) What is the angle of inclination of the earth's axis from its orbit?
 (b) State two effects of the rotation of the earth
2. (a) What is magma?
 (b) Differentiate between a sill and a dyke
 (c) The diagram below represents a composite volcano. Name the features marked P, Q, and R

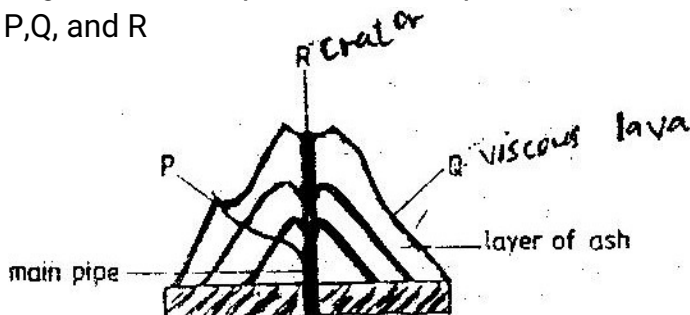

3. (a) State three causes of earthquakes
 (b) Give two effects of earthquakes in built up areas
4. (a) name the type of delta found at the mouth of
 (i) River Nile
 (ii) River Omo
 (b) State three conditions that are necessary for the formation of delta

5. (a) name three external land forming processes that leads to the formation of lakes
 (b) State two ways in which lakes influence the natural environment

SECTION B

Answer questions 6 and any other two questions from this section

6. Study the map of Mariakani (1:50,000 sheet 197/4) provided and answer the following questions
 - (a) (i) What type of map is Mariakani sheet?
 (ii) From the marginal information, identify the two districts covered by the map
 (iii) Calculate the area of Mavirivirini sub- location. Give your answer in square kilometers.
 - (b) Citing evidence from the map, explain three factors that favour cattle rearing in Mariakani area.
 - (c) Citing evidence, state three functions of Samburu town
 - (d) Some students are required to carry out a field study on water supply in south Samburu Division.
 - (i) State four problems they are likely to encounter in administering questionnaires to residents of the area.
 - (ii) Measure the length of a water pipeline proposed by the students from existing line at grid reference 303796 to Mwandoni settlement at grid reference 325720. Give your answer in Kilometers.
 - (iii) Calculate the vertical rise (amplitude of relief) of the proposed pipeline.
7. (a) (i) What is the difference between weathering and mass wasting
 (ii) List Five process involved in chemical weathering
 (b) Explain five ways in which soil creep occurs
 (c) Describe three effects of soil creep
8. The graph below represents the climate of a station in Africa. Use it to answer question



9. (i) Describe the characteristics of the climate represented by the graph
(ii) Describe the type of natural vegetation likely to be found in an area with the type of climate represented by the graph.
- (a) Explain four factors that influence climate.
- (b) You intend to carry a field study on the weather experienced in the locality of your school
- (i) State three ways in which you would prepare for the study
- (ii) Describe how you would use the following instruments during the study
A rain gauge (Used to collect rain water)
Maximum and minimum thermometer
- (iii) State three advantages of studying the weather through Fieldwork
10. (a) On the outline map of Africa provide, name the features marked X,Y and Z



- (b) (i) Name four folds
(ii) With the labeled diagrams, describe the formation of fold mountains

(iii) Explain four ways in which fold Mountains influence human activities.

GEOGRAPHY
PAPER 1
1999
2 ³/₄ HOURS
Oct / Nov.

SECTION A

Answer all the questions in this section

1. Give four proofs that the earth is spherical
2. (a) State two conditions considered in choosing a suitable site for a weather station
(b) Name two weather recording instruments that are placed in a Stevenson's screen
(c) Give two reasons why weather forecasting is important
3. The diagram below represents the flow of air current. Use them to answer question

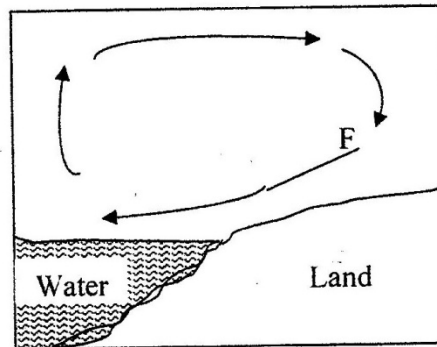
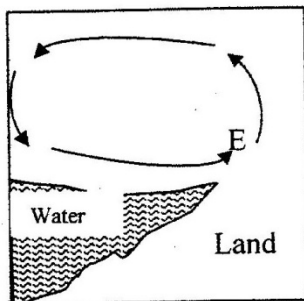

- (a) (i) In your answer booklet, name the air current marked E
(ii) Why does the air cool as it rises
(b) Give the reason why air cools as it rises
4. (a) The diagram below shows a barchan

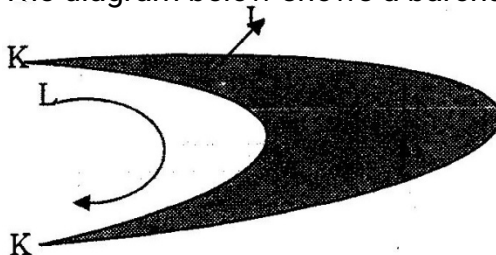

- (ii) Name the air current marked L

(b) How is an oasis formed?

5. The diagram below represents a coastal landform

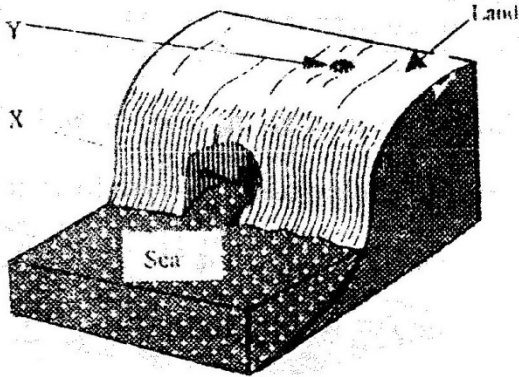

(a) Name the features marked X and Y

(b) State three conditions necessary for the formation of a sand spit.

SECTION B

Answer questions 6 and two other questions from this section

6. Study the map provided. (Yimbo 1:50,000 sheet 115/1) and answer the following questions

- (a) (i) What is the bearing of the air photo principal point in the grid square 3274 from the trigonometrical station in the grid square 2778?
- (ii) Give the latitudinal extent of the area covered by the map

(b) Draw square 15 cm x 15 cm to represent the area bounded by the Easting 12 and 20 and the Northings 90 and 99

In the square you have drawn, mark and label

- (i) Busia District
 - (ii) LakeSare
 - (iii) All weather loose surface road
- (c) Name two features shown on the map that indicate that the area receives low rainfall.
 - (d) Citing evidence from the map, state three economical activities carried out in the area covered by the map.
 - (e) Describe the relief of the area covered by the map
 - (f) Suppose you are a student from Pala school (grid square 2793) and are planning to carry out a field on the velocity of the part of river Yala shown on the map.

- (i) What preparations are likely to make for the study?
- (ii) State three problems you are likely to experience during the field study
- (iii) State two follow – up activities you are likely to carry out after the filed study.

7. The block diagram below shows the feature resulting from glaciating in a lowland region. Use it to answer questions (a)

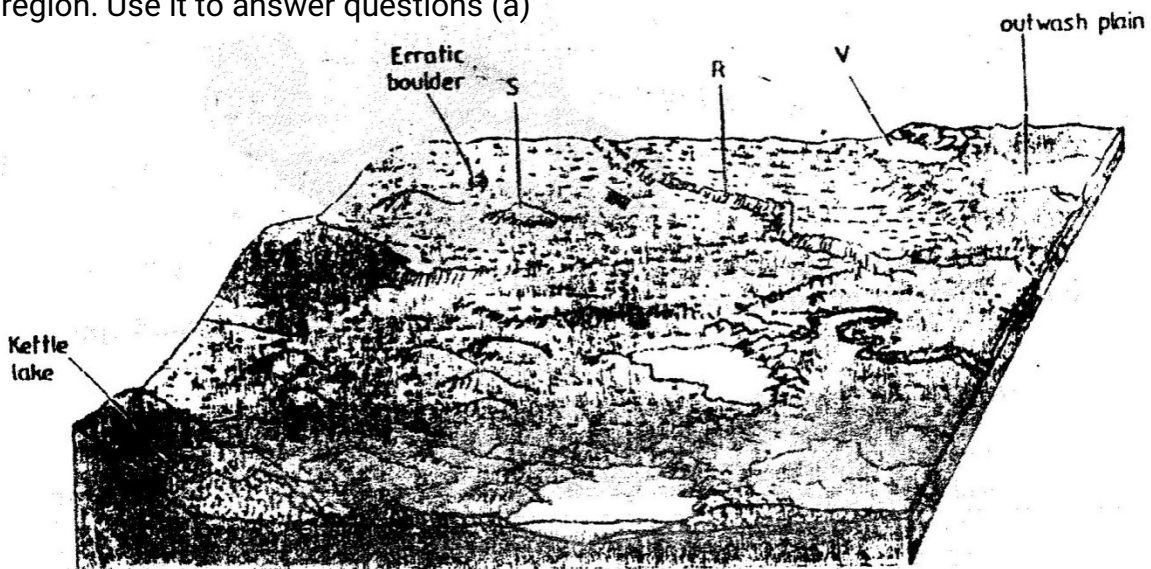

- (a) In your answer booklet, name the features marked R, S, and V
 - (b) Explain three conditions that may lead to glacial deposition in lowlands
 - (c) Describe the process involved in the formation of
 - (i) Moraine dammed lake
 - (ii) Outwash plain
 - (d) Suppose you were to carry out field study of land use in glaciated lowland.
 - (i) Apart from conducting oral interviews, state four other methods you would use to collect information
 - (ii) State three advantages of using oral interview to collect information during a field study.
 - (iii) State three possible land uses you are likely to identify during the field study
8. (a) describe how a river erodes its channels by the following process.
- (i) Hydraulic action
 - (ii) Abrasion
- (b) (i) Explain three factors that lead to rejuvenation of a river
- (ii) Describe the process of a river capture.

The map below shows some drainage patterns of some river systems in Kenya. Use it to answer questions (c) (i)

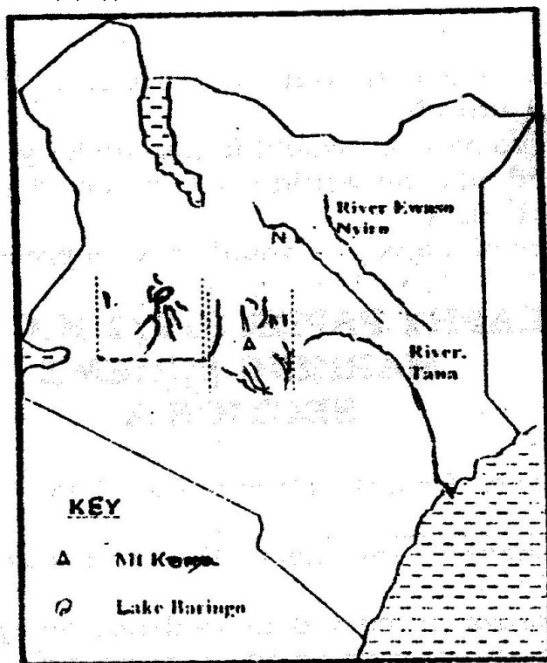

- (c) (i) Identify the drainage patterns labeled I, M and N
- (ii) Describe the formation of a braided drainage pattern

9. The diagram below represents zones of natural vegetation on a mountain use it to answer questions (a)

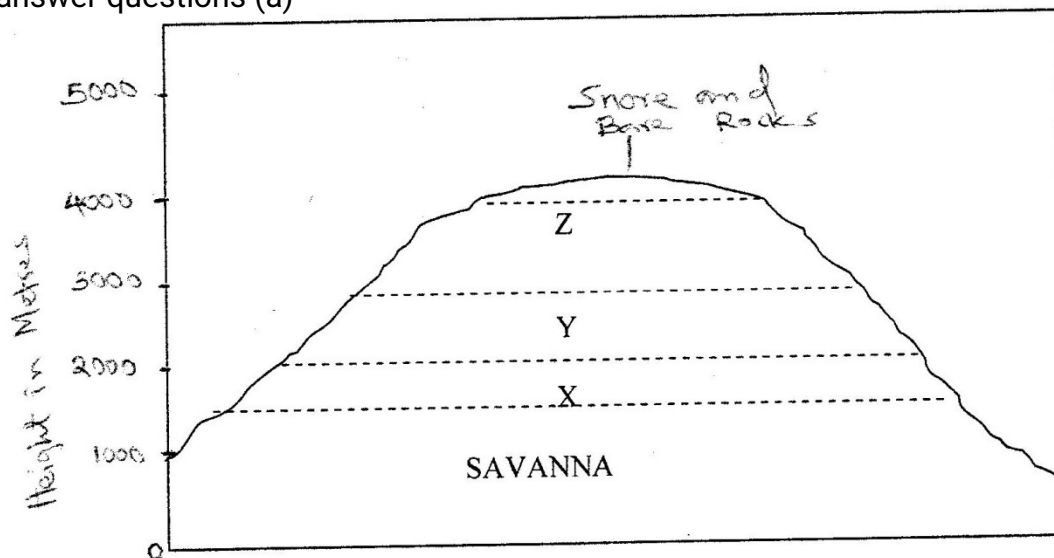

- (a)
 - (i) In your answer booklet, name the zones marked X,Y and Z
 - (ii) Describe the characteristics of a tropical Savannah vegetation
 - (iii) State two reasons why the mountaintop has no vegetation
- (b) Explain three factors that have led to a decline of the natural grassland in Kenya.
- (c) Suppose you were to carry out a field study on the relationship between vegetation and altitude
 - (i) State three objectives you would formulate for your study
 - (ii) State three methods you would use to record the information collected during the field study
 - (iii) Name two types of maps you would draw to present your findings.

Section A

Answer all the questions in this section

1. (a) Name two elements of weather that can be recorded at a school weather station
(b) Give three reasons why the recording of data at a school weather station may be inaccurate

2. (a) State two factors which influence the occurrence of surface run-off
(b) The diagram below shows a waterfall. Name the feature marked X, Y and Z

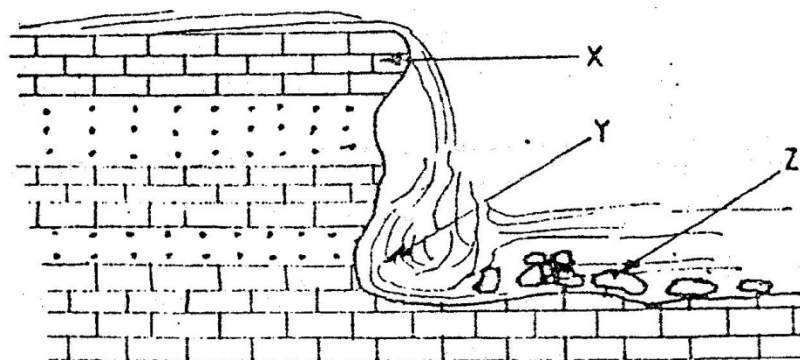

3. (a) State two causes of submergence of coasts
(b) Name two features that form as a result of submergence of coasts

4. (a) What is soil?
(b) The diagram below shows a cross – section of a hillside and soil profiles that develop at different parts of the hillside

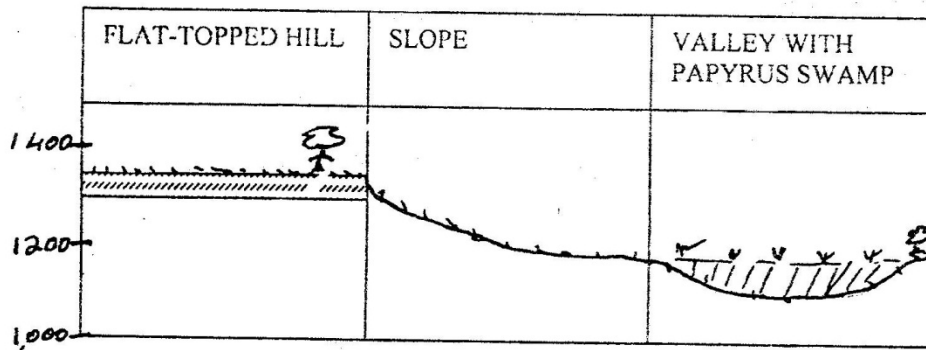
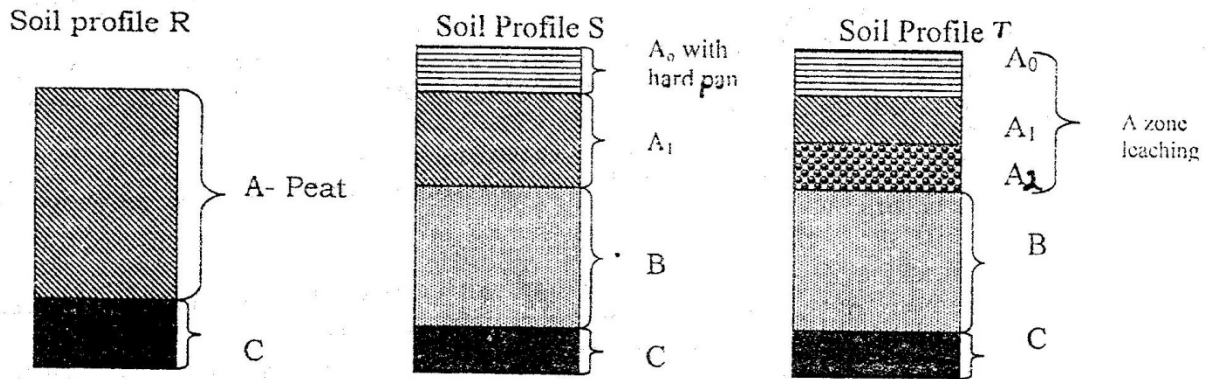

Match the soil profiles with the corresponding parts of the hillside where each profile is likely to develop

5. The diagram below shows a glaciated upland area

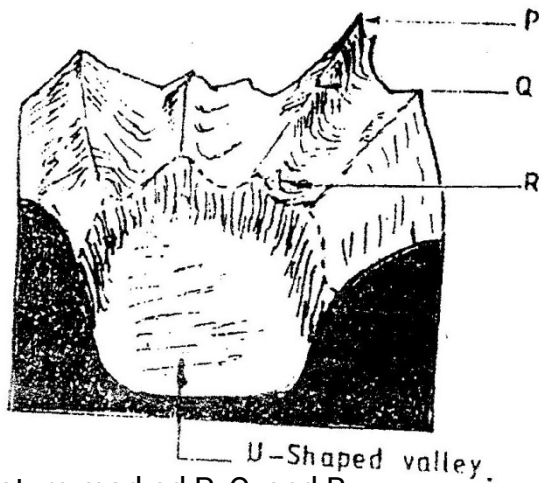

(a) Name the feature marked P, Q, and R

(b) How is a U-shaped valley formed?

SECTION B

Answer questions 6 and any other two questions from this section

6. Study the map of Mathioya 1: 50,000 provided and answer the following questions

- (a) (i) What is the bearing of the cattle dip at grid reference 716386 from the coffee factory at grid reference 740377?
- (ii) Give the approximate height of Kigoini dam
- (iii) Measure the length of the district boundary in the Aberdare forest from Western margin of the map to the eastern edge of the forest
(Give your answer in kilometers)
- (b) Describe the drainage of the area covered by the map
- (c) Draw a sketch section along northing 42 from grid reference 720420 to grid reference 760420
On the section mark and name
- (i) A road
- (ii) A forest
- (iii) A river
- (d) Describe the distribution of settlements in the area covered by the map
- (e) (i) Citing evidence from the map, give two reasons why the area covered by the map is suitable for coffee growing
- (ii) Apart from agriculture, name two other economic activities carried out in the area covered by the map
7. (a) Differentiate between plutonic rocks and volcanic rocks
- (b) Describe how lava plateau is formed
- (c) (i) Name three volcanic features found in the rift valley of Kenya
- (ii) Explain four negative effects of vulcanicity in Kenya
- (b) You intend to carry out a field study of a volcanic landscape
- (i) State four reasons why it is necessary to conduct a reconnaissance of the area of study.
- (ii) During your field work, you intend to study volcanic rocks, state why you would need the following items
8. (a) State three characteristics of the inter-tropical convergence zone
- (b) With the aid of a labeled diagram, describe how relief rainfall is formed
- (c) State five characteristics of the hot desert climate
- (d) You are required to carry out a field study to determine the relationship between climate and vegetation in your district
- (i) Give three reasons why you would need the map of the district
- (ii) Name two sampling techniques you are likely to use during the field study
- (iii) Give two reasons why sampling would be appropriate for this study

- (iv) State four methods you would use to record data during the field study
9. (a) (i) Describe how lake Victoria was formed
(ii) Explain how Lake Victoria has modified the climate of the surrounding
- (b) Explain why some lakes in the rift valley have fresh water
- (c) State five economic uses of lakes
- (d) Explain how each of the following have affected lakes in Kenya
(i) Deforestation
(ii) Industrialization
(iii) Water weeds

SECTION A

Answer all the questions in this section

1. (a) (i) Give the two dates in a year during which the number of hours of darkness is equal in both the north and south poles.
 (ii) Why do the lengths of days and nights vary from one part of the earth to another?
- (b) The diagram below shows the revolution of the earth around the sun. Use it to answer the questions that follow

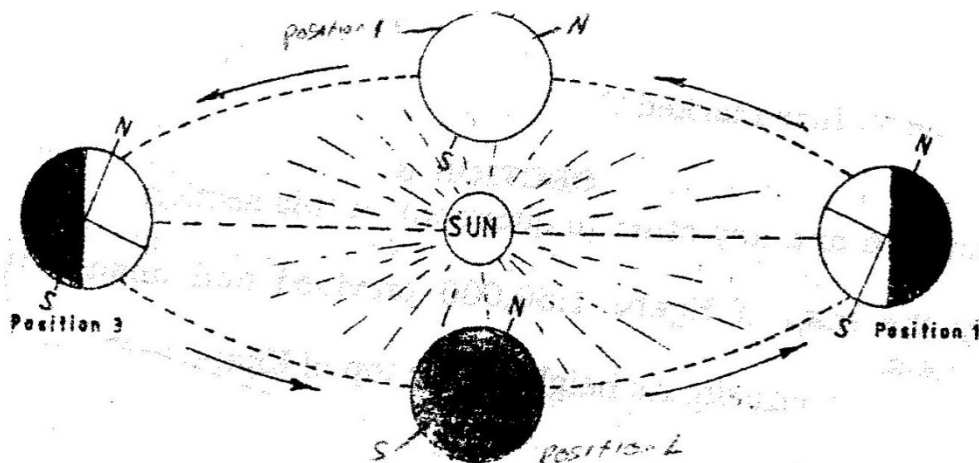

- (i) If the earth takes 366 days to make a complete revolution during a leap year, how long will it take to move from position 1 to position 4?
 (ii) What season is experienced in the southern hemisphere when the earth is in Position 1?
2. (a) State two conditions that are necessary for the formation of fog.
 (b) The diagram below shows some types of clouds. Use it to answer the questions that follow.

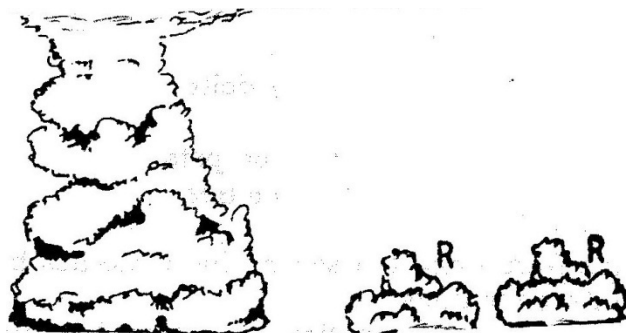

- (i) Name the clouds marked R

(ii) Give two weather conditions associated with cumulonimbus clouds

3. (a) What is mechanical weathering?
(b) How is an exfoliation dome formed?
4. (a) State three climatic conditions experienced in the Sahara desert
(b) State three ways in which plants adapt to hot desert conditions
5. (a) What are natural levees?
(b) The diagrams below shows a section of a river. Use it to answer the questions that Follow.

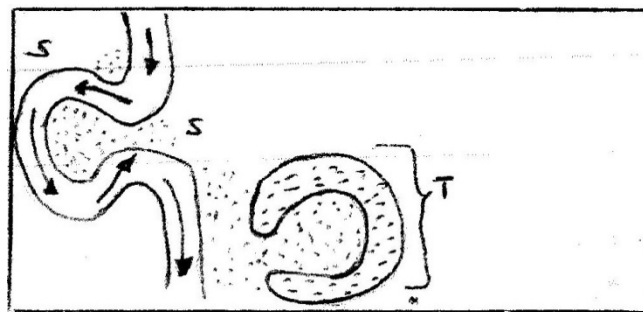

KEY
→ River current
••• River deposits

- (i) At what stage development is this section of the river?
- (ii) Name the natural process that takes place at the part marked S
- (iii) Name the feature marked T.

SECTION B

Answer questions 6 and any other two questions in this section

6. (a) Study the map of Kijabe 1: 50,000 provided and answer the following questions:
 - (i) What is the appropriate height of the top of Kijabe hill?
 - (ii) Measure the length of Nairobi – Naivasha railway line from landhies (grid reference 257978) to the level crossing near Kijabe station (grid reference 308984). Give your answer in kilometers.
 - (iii) What relief feature on the map may have created problems in the construction of the railway line?
- (b) Describe the drainage of the area covered by the map
- (c) Explain how relief has influenced the distribution of settlement in the area covered by the map.
- (d) Citing evidence from the map, state four economic activities carried out in the area covered by the map.
- (e) Suppose you were a student in the school at Kinari (Kinale) and you plan to carry out a field study of Wakagwe forest,

- (i) Design a working programme (schedule) you would use during the day of the study
 - (ii) Give three reasons why it would be necessary to sample part of the forest for the study
 - (iii) State two ways in which your findings would be useful to the local community.
7. (a)
- (i) What is a rock?
 - (ii) Describe three ways through which sedimentary rocks are formed
 - Mechanically formed
 - Organically formed
 - Chemically formed
- (a) Describe two process through which sedimentary rocks changer into metamorphic rocks
- (b) Give an example of each of the following types of igneous rocks
- (i) Plutonic rocks
 - (ii) Hypabyssal rocks
 - (iii) Volcanic rocks
- (e) Suppose you were to carry out a field study of rocks within the vicinity of your school
- (i) Name three secondary sources of information you would use to prepare for the field study
 - (ii) State four activities you would carry during the filed study
 - (iii) State three problems you are likely to experience during the field study
8. (a) Name two types of submerge coasts
- (b) Explain how the following factors determine the effectiveness of wave erosion along a coast
- (i) Nature of the material transported by waves
 - (ii) Nature of the coastal rocks
- (c) With the aid of labeled diagrams, describe the process through which a stack is formed
- (d) (i) State four conditions that favour the growth of coral
- (ii) Explain three ways in which coral contributes to the economic development of Kenya.
9. (a) Name three components of soil
- (b) Explain how the following factors influence the formation of soil
- (i) Climate
 - (ii) Topography
- (c)
- (i) State two economic uses of soil

- (ii) Explain four ways in which human activities contribute to soil erosion
- (d) Describe how the following types of erosion occur
 - (i) Sheet erosion
 - (ii) Gully erosion

GEOGRAPHY
PAPER 1
2002
2 3/4 HOURS
Oct / Nov.

SECTION A

Answer all the questions in this section

1. The diagram below represents features produced by faulting. Use it to answer questions that follow.

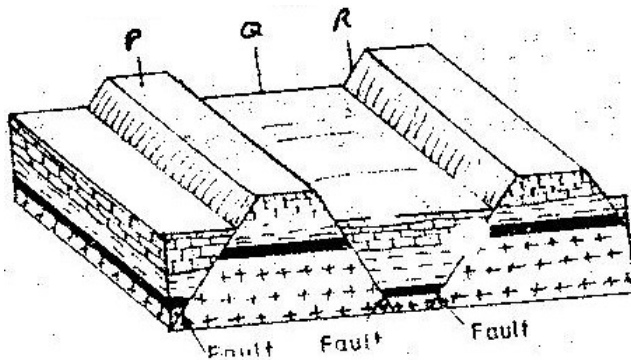

- a) Name the features marked P,Q, and R
 - b) Differentiate between a normal fault and a reverse fault.
2. Use the diagram below to answer question (a)

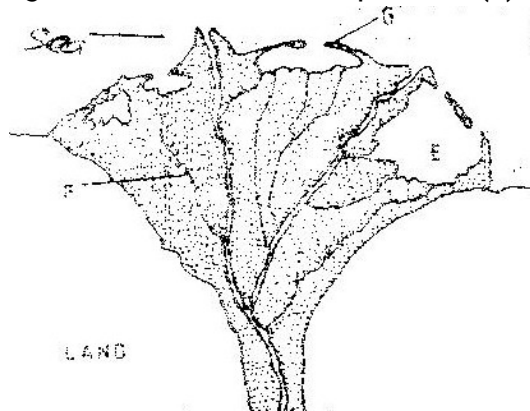

- a)
 - i) What type of a delta is represented by the diagram?
 - ii) Name the features marked E,F, and G.
 - c) State two conditions necessary for the formation of a delta.
3. a) what is desertification?
 b) State two negative effects of desertification.
4. a) The table below shows climatic data of a station in Kenya. Use it to answer question(a)

Month	Jan	Feb	Mar	April	May	June	Jul	Aug	Sep	Oct	Nov	Dec
Temp in °C	28.9	29.7	30.3	29.9	29.7	29.2	28.4	28.7	29.6	30.1	29.2	28.7
Rainfall in mm	9.0	8.0	21.0	49.0	25.0	9.0	20.0	10.0	4.0	10.0	17.0	11.0

- i) What is the annual range of temperature at the station?
 - ii) Calculate the total rainfall for the station.
- b) State three factors that influence climate.
5. a) What is the solar system?
- b) Use the diagram below to answer the questions that follow.

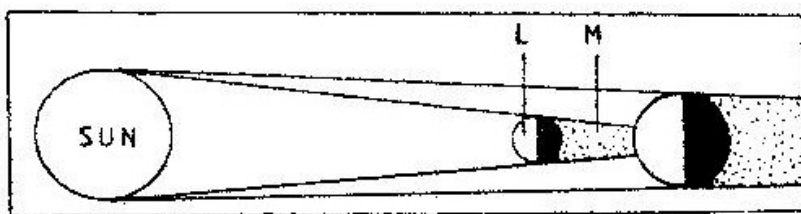

- i) What type of eclipse is represented by the diagram?
- ii) Name the features marked L and M

SECTION B

Answer questions 6 and any other two questions in this section

- 6 Study the map of Kisumu East (1:50000) provided and answer the following questions.
- i) What is the bearing of the trigonometrical station at Grid reference 081980 from the rock out crop at grid reference 071992.
 - ii) Measure the length of the all – weather road (bound surface) b2 /1 from the junction at grid reference 947911 to the edge of the Map, grid reference 947667.(Give your answer in kilometers)
 - iii) On a rectangle, mark and name:
- b) i) Describe the relief of the area covered by the map.
- ii) Explain how relief has experienced settlement in the area covered by the map.
- c) Citing evidence from the map, give three economic activities carried out in the area covered by the map other than crop growing.

Economic Activities

Evidence

Quarrying

Processing

Transportation.

d) Students from the school at Mosongo (Grid square 0681) carried Out a field study of the course of the river Ombeyi.

i) State three findings they are likely to have come up with.

ii) Give three advantages of studying rivers through fieldwork.

7. The map below shows the physical regions of Kenya. Use it to answer the questions that follow.

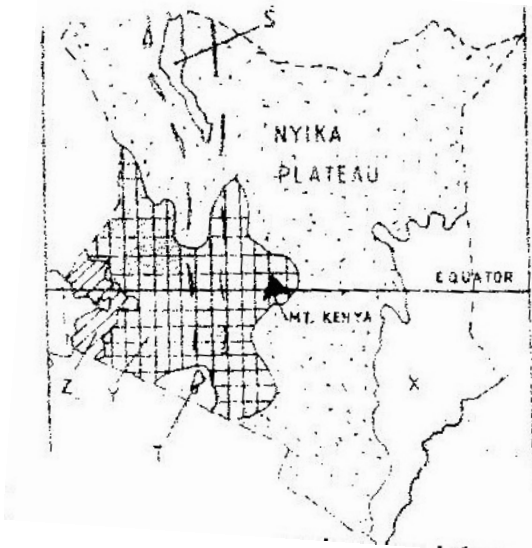

a) i) Name the regions marked.

ii) Give the major economic importance of each of the lakes marked S and T.

iii) Describe how Mt. Kenya was formed.

iv) State three ways through which Mt. Kenya has influenced the drainage of the area.

c) Suppose students are to carry out a field study of the soils found in the Nyika plateau.

i) State three methods they are likely to use to collect data.

ii) The students identify the soils for further analysis. Give three characteristics of the desert soils that they are likely to study.

8. The map below shows some vegetation regions of the world. Use it to answer questions (a) to (c).

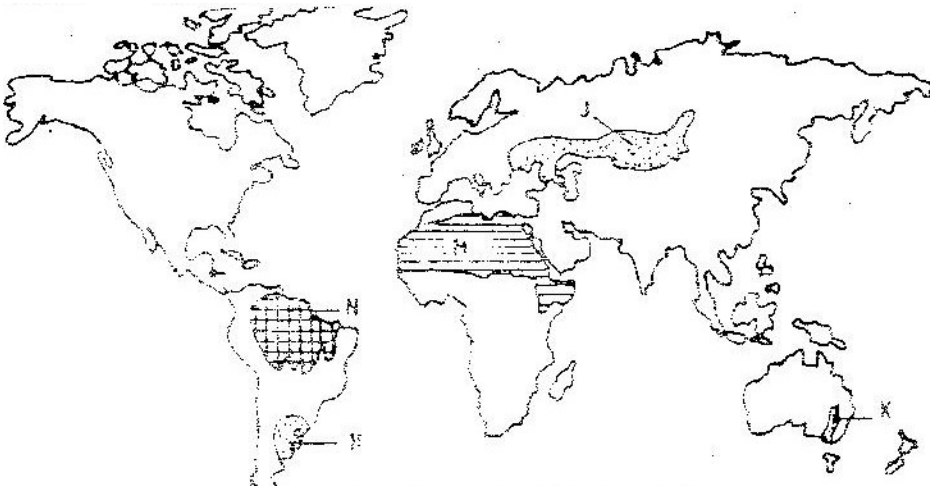

- a) Name the temperate grasslands marked H, J and K.
- b) Describe the characteristics of the natural vegetation found in the shaded area marked N.
- c) i) Explain four ways in which the vegetation found in the area marked M adapts to the environment conditions of the region.
- d) You are required to carry out a field study of the vegetation within the local environment:
 - i) a part from identifying the different types of plants, state three other activities you will carry out during the field study.
 - ii) How will you identify the different types of plants?

9. The diagram below represents the internal structure of the earth. Use it to answer question(a)

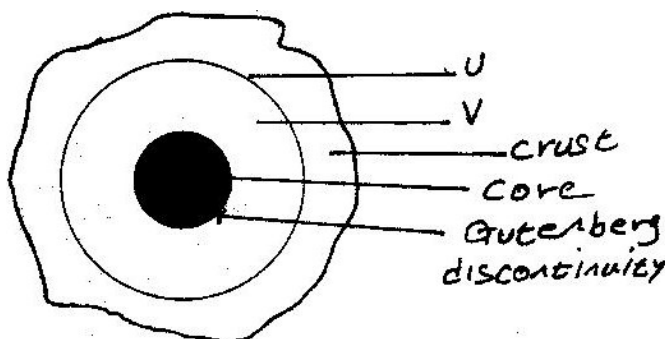

- (a) Name the part marked U and V.
- (b) Describe the deposition of:
 - i. The crust
 - ii. The core
- (c) (i) What are earthquakes
 (ii) Name two types of earthquakes.
 (iii) State the five ways in which the earths' crust is affected by earthquakes.
- (d) You intend to carry out a field study of an area recently affected by intense earthquake.
 - i. Give two sources of information that you would use in preparation for the study.
 - ii. Explain two factors that would make it difficult for you to collect accurate data during the field study.

GEOGRAPHY
PAPER 1
2003
2 ³/₄ HOURS
Oct / Nov.

SECTION A

Answer all the questions in this section

1. a) State TWO factors that influence the rate of erosion by the river in its upper course.
b) (i) Define river rejuvenation
Name two features that result from river rejuvenation
2. a) State three conditions necessary for the development of a Karst scenery
b) Give two reasons why there are few settlements in Karst landscapes
3. a) State two conditions which may influence the occurrence of landslides
b) Using the diagram (in question paper), name

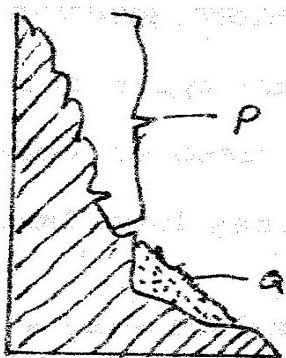

- (i) The type of mass movement shown
 - (ii) The features marked P and Q
4. a) i) In your answer booklet draw a diagram to show a simple fold and on it mark and name
b) Name two fold mountains in Africa
 5. a) Name the type of rocks which results from the metamorphism of:
(i) Granite
(ii) Clay
b) Give two reasons why sedimentary rocks are widespread in the coastal plain of

Kenya.

SECTION B

Answer questions 6 and any other two questions in this section

6. Study the map of Menu (1: 50,000, sheet 108/3) provided and answer the following questions

- a) i) What is the height of Njorivola hill at grid square 4117
ii) Give two methods used in representing religion the map contract
iii) Measure the bearing of the peak of Kanjai hill form the peak of Kieru hill to the north east of the map extract.
- b) Citing evidence from the map, explain:
(i) Two factors trading in the area covered by the map
- c) The rectangle (in the question paper) represents the area in the map extract bounded by Easting 35 and 40 and Northing and Northing 02 and 10. Use it to answer the questions that follow.

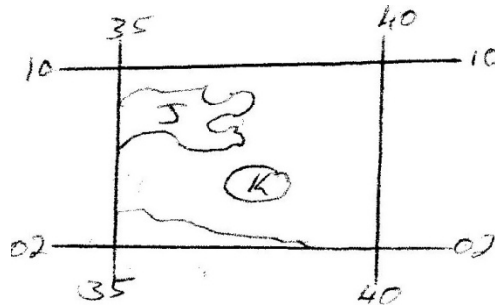

Identify the name the features marked;

- J-
- K-
- L-

- (i) Measure the length of the road they followed from the junction at grid reference 442128 to the junction at Gitoro, grid reference 478069. Give your answer in kilometers
- (ii) Apart from the forest, name two other types of natural vegetation they observed along the route
- (iii) State two methods they may have used to collect data while at the sawmill
- iv) State three follow- up activities they may have been involved in after the field study.

- 7 a) (i) What is a glacier?
(ii) Distinguish between valley glaciers and ice sheets
- b) The diagram (in the question paper) represents an upland glaciated landscape. Use it to answer question b (i) and (ii)
(i) Name the features Marked D, E and F
(ii) Describe how pyramidal peak is formed
- (c) Explain the significance of upland glaciated features to human activities
- (d) Students from a school near Mt. Kenya were planning to carry out a field study of the glaciated features on the top of the mountain.
(i) Give four reasons why it would be difficult for the students to undertake the field study on the glaciated features on the mountain
(ii) Kenya to describe how the students would use a photograph of Mt. identify the glaciated features of the mountain.
- 8 a) the tables below represent rainfall and temperature of stations X and Y. Use them to answer questions (a) and (b)

MONTHS	J	F	M	A	M	J	J	A	S	O	N	D
TEMPERATURE IN °C	30	31	31	31	30	29	29	28	28	29	29	30
RAINFALL IN MM	250	250	325	300	213	25	25	25	100	275	380	200

MONTHS	J	F	M	A	M	J	J	A	S	O	N	O
TEMPERATURE IN °C	21	20	20	17	15	13	12	13	15	16	18	20
RAINFALL IN MM	12	12	15	50	90	110	87	87	50	35	20	15

- a) (i) for each of the two stations calculate the mean annual temperature.
X -
Y -
- (ii) Calculate the annual rainfall for station Y
- (iii) On the graph paper provided, draw a bar graph to represent rainfall for station x. Use vertical scale of 1cm to represent 50mm
- b) Describe the climatic characteristics of station Y.
- c) (i) Describe how conventional rainfall in the lake region of Kenya
- 9 a) (i) Two process through which wind erodes the surface
(ii) Three ways through which wind transports its load
- b) (i) How an oasis is formed

- (ii) How zeugens are formed
 You are supposed to carry out a field study of a semi-arid area in Kenya.
- c) (i) Two ways of preparing for the Field study
 (ii) Information that would be collected through observation of the arid area
 (iii) Measures to be recommended for controlling desertification.

**GEOGRAPHY
 PAPER 1
 2004
 2 ³/₄ HOURS
 Oct / Nov.**

SECTION A

Answer all the questions in this section

1. a) Name two types of soil according to texture (2mks)
 b) State two ways in which humus improves the quality of soil (2mks)
2. a) What is latitude?
 b) What is the time at Hola on 40° E when the time at Tema on 0° longitude is 12.00 noon? (2mks)

3. The diagram below show some features of a Karst scenery. Use it to answer questions (a)

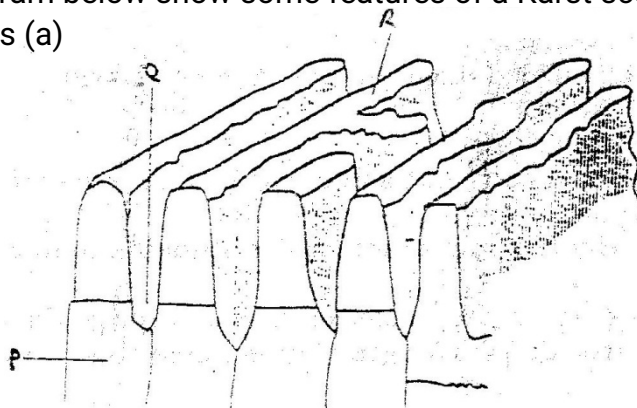

- a) Name the features marked P, Q, and R. (5mks)
 b) Describe carbonation as a process of Chemical weathering (3mks)
4. a) What do you understand by:
 (i) Microclimate?
 (ii) Green house effect?
 b) Name three instruments to match three elements of weather that can be measured at a school weather station (3mks)

- 5 a) What is a lake?
 b) State three ways through which lakes are formed? (3mks)

SECTION B

Answer question questions 6 and any other two questions from this section

6. Study the map of Kipkabus (1:50,000, sheet 104/4 provided and answer the following questions.
- a) (i) give the latitude and longitude of the South west corner of the map extract. (2mks)
 (ii) What is the area of Tingwa Hill Forest? (2mks)
- b) (i) name the planted vegetation in the area covered by the map (1mk)
 (ii) Explain how relief and human activities have influenced the distribution of natural vegetation in the area covered by the map (4mks)
- c) i) Using a vertical scale of 1 cm to represent 100 meters draw a cross section Along the line marked X-Y (5mks)
 ii) On the cross section mark and label the following:-
 A steep slope
 A hill
 A col
 A river valley (4Mks)
 iii) Calculate the vertical exaggeration of the cross section (2mks)
- d) Student of Chepkeret school carried out a field study of Kipkabus town.
- i) Name **two** types of roads they used to travel to Kipkabus (2mks)
 ii) State **three** functions of Kipkabus that they identified (3mks)
7. a) i) A part from the Rift Valley name two other relief features that were formed as result of faulting. (2mks)
 ii) With the aid of a well labeled diagram, describe how a Rift Valley is formed by tensional forces. (8mks)
- b) Explain four effects of faulting (8mks)
 c) Students are planning to carry out a field study of an area affected by faulting

- i) State four reasons why it is important for the students to have a pre-visit of the area (4mks)
- ii) One of the ways they would use to collect data is through direct observation. Give three disadvantages of direct observation in the study of such an area. (3mks)

- 8.
- a) State four factors that determine the amount of surface run off (4mks)
 - b) Describe three ways in which a river transports its load (6mks)
 - c) Using a diagrams, describe the following drainage patterns
 - i) Dendritic (2mks)
 - ii) Trellis (2mks)
 - iii) Centripetal (2mks)
 - d) A form **four** class is planning to carry out a field study of a waterfall.
 - i) State five ways in which they would prepare for the study (5mks)
 - ii) Give four methods they would use to collect information at the waterfall (4mks)

9. The diagram below shows some intrusive features formed by vulcanicity. Use it to answer question (a)

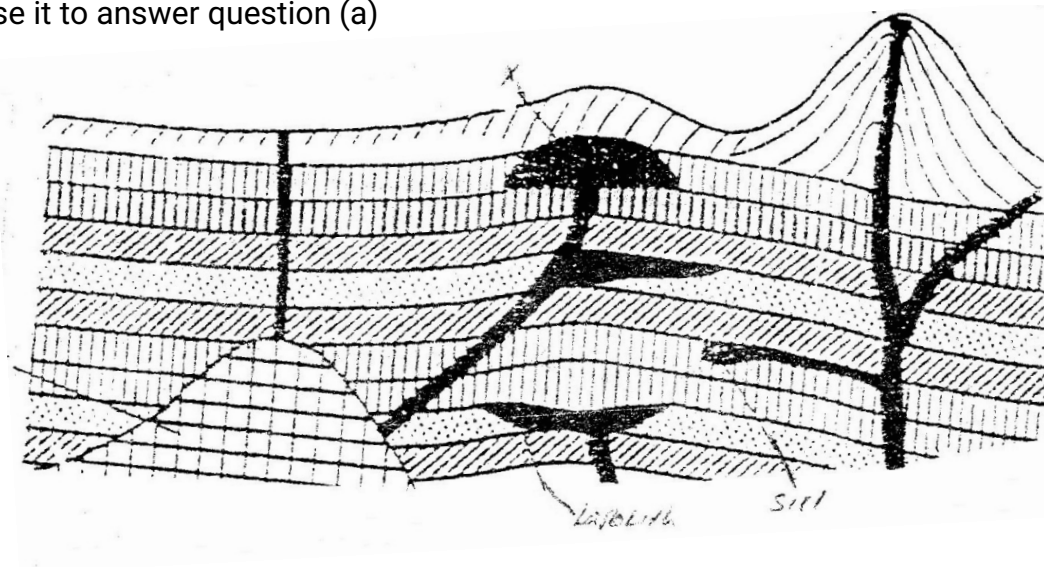

- a)
 - i) Name features marked X,Y, and Z (3mks)
 - ii) Explain how a sill is formed (4mks)
- b) Describe the characteristics of a composite volcano (4mks)
- c) Explain **four** ways in which volcanic mountains positively influence human activities. (8mks)
- d) Students carried a field study on volcanic rocks
 - i) Give **four** reasons why it is necessary to collect rock samples during such a field study. (4mks)

- ii) State **two** problems they are likely to have experienced during the field study (4mks)

GEOGRAPHY
PAPER 1
2005
2 ³/₄ HOURS
Oct / Nov.

Answer all the questions in this section

SECTION A

1. (a) Name two theories of the origin of the earth (2 mks)
(b) Name four layers of the earth's atmosphere (4 mks)
2. (a) The diagram below shows the hydrological cycle. Name the stages marked E, F, and G (3mks)

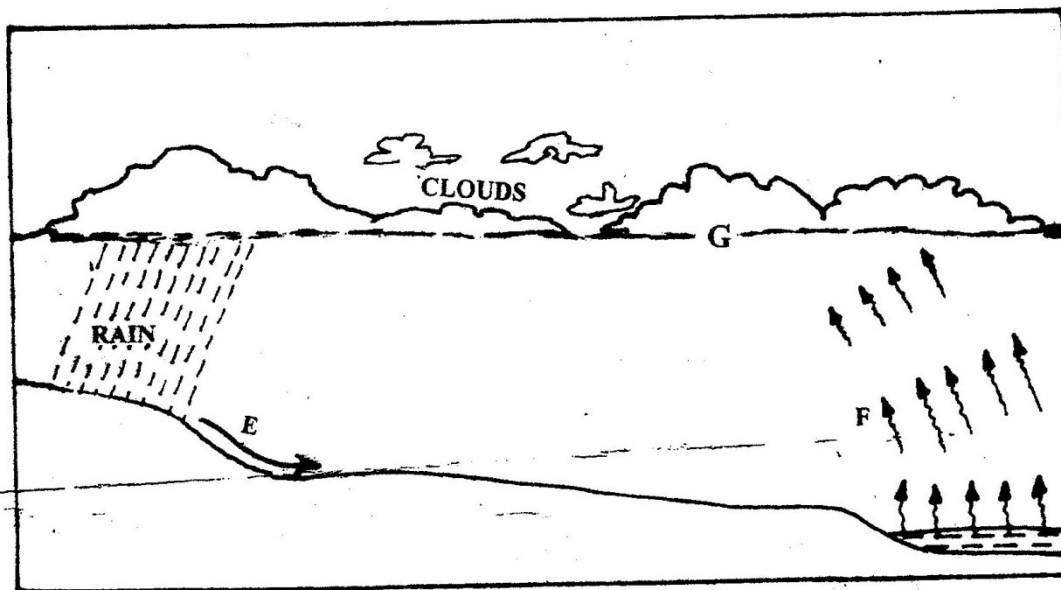

- (b) Differentiate between watershed and a catchments area (2 mks)
3. (a) State two characteristics of sedimentary rocks (2mks)
(b) Give two examples of chemically formed sedimentary rocks (2mks)
4. (a) Name a place in Kenya where tarns are found (1mk)

- (b) Describe how a tarn is formed (4 mks)
5. (a) What is a natural vegetation? (2mks)
 (b) State three characteristics of Mediterranean vegetation (3 mks)

SECTION B

Answer questions 6 and any other two questions in this section

6. Study the map of SILALONI (1:50,000) provided and answer the following questions
- (a) (i) Convert the ratio scale of the map extract into a statement scale (1 mk)
 (ii) Give the six – figure grid reference of the point where the power line crosses the Samburu – Silaloni dry weather road (1 mk)
 (iii) Give three types of natural vegetation shown in the area covered by the map (2 mks)
- (b) (i) Identify two sources of water in the area covered by the map (2mks)
 (ii) Using evidence from the map, suggest four functions of Tsangatsini township. (4mks)
- (c) Using a vertical scale of 1 cm to represent 20m:
 (i) draw a cross section from grid reference 400915 to 500915 (3 mks)
 (ii) On the cross section, mark and name the following:
 ❖ A river
 ❖ A road
 ❖ A quarry
 (iii) Calculate the vertical exaggeration of the section you have drawn (2 mks)
- (d) Students at Silaloni school (grid square 3199) carried out a field study on the soils around the school
 (i) Give four reasons why a reconnaissance was necessary for the field study (4mks)
 (ii) Name two types of soils they collected (2mk)
7. Use the diagram below to answer question (a)

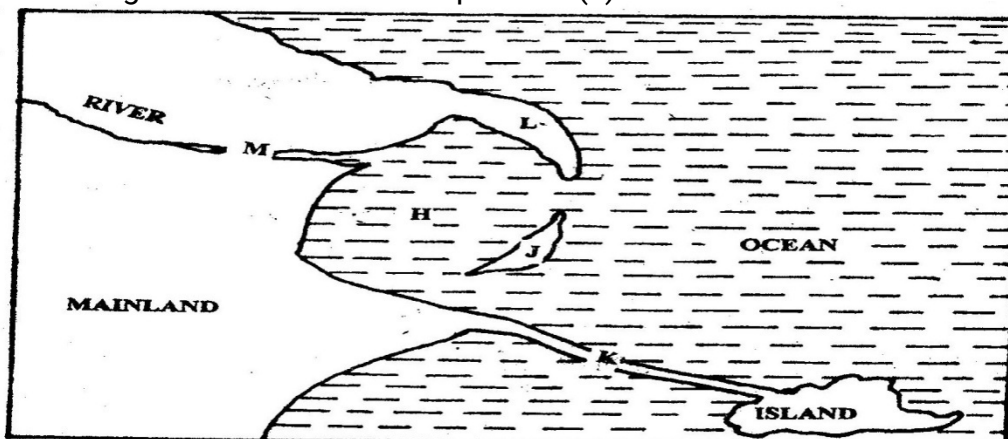

- (a) Name the coastal features marked H,J,K,L and M (5mks)
- (b) (i) state four conditions necessary for the formation of a beach (4mks)
- (ii) Describe three processes involved in marine erosion (6mks)

- (b) You are planning to carry out a field study on the depositional features along the coast of Kenya
- (i) State five objectives you would formulate for your study (5mks)
- (ii) Give five methods you would use to record the information collected (5mks)

8. (a) Name one fold mountain in:

- (i) Asia (1mk)
- (ii) North America (1mk)
- (iii) South Africa (1mk)

- (b) (i) Apart from fold mountains, name three other features resulting from folding (3mks)
- (ii) With the aid of a labeled diagram, describe the formation of an thrust fold

(c) Explain four effects of fold mountains on human activities (8mks)

- (d) Students are planning to carry out a field study on landforms in their strict.
- (i) State three ways in which the students would prepare themselves for the field study (3mks)
- (ii) Give two advantages of studying landforms through field work (2mks)

9. Use the map below to answer questions (a) and (b)



- (a) Name:
- (i) The type of climate found in the shaded area marked Q (1 mk)
 - (ii) The ocean current marked R and S (2 mks)
- (b) Describe the characteristics of the type of climate found in the shaded area marked T (8 mks)
- (c) Explain how the following factors influence climate
- (i) Altitude (4 mks)
 - (ii) Distance from the sea (4 mks)
- (c) (i) Describe a suitable site where you would locate a weather station in your School (2 mks)
- (ii) Give reasons why a Stevenson's screen is:
- Painted White (2 mks)
 - Has louvers (2 mks)

GEOGRAPHY
PAPER 1
2006
2 ³/₄ HOURS
Oct / Nov.

Answer all the questions in this section
SECTION A

1. (a) How does a sea breeze occur? (2 mks)
(b) Use the map of Africa below to answer questions (b) (i)

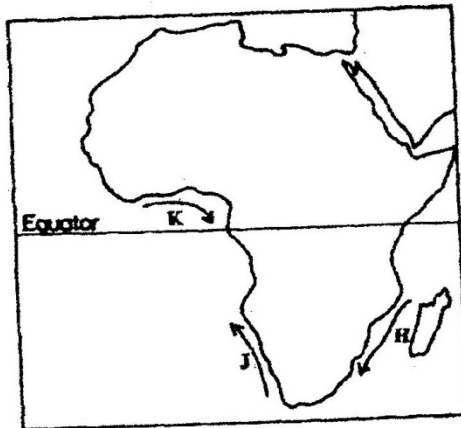

- (i) Name the ocean currents marked H,J, and K (3 mks)
(ii) State two effects of a warm ocean current on the adjacent coastlands (2 mks)
2. Give two processes involved in each of the following types of weathering
(a) Physical weathering (2 mks)
(b) Chemical weathering (2mks)
3. The diagram below shows the composition of the solar system

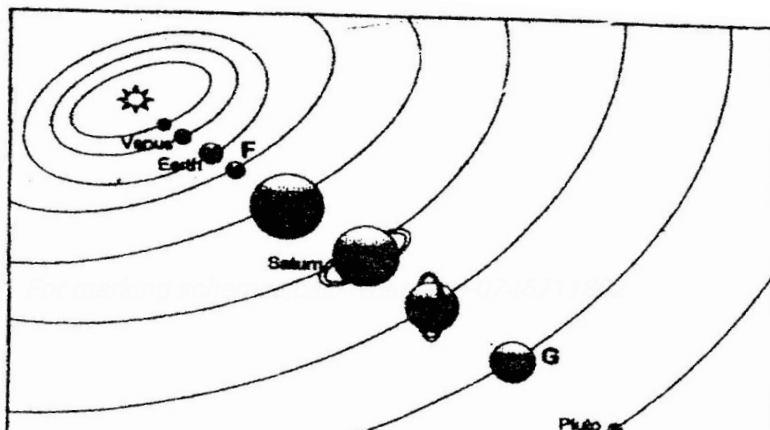

- (a) Name the planets marked F and G (2 mks)
 (b) State three effects of the rotation of the earth on its axis (3 mks)
4. (a) Name two scales used to measure the intensity of an earthquake (2 mks)
 (b) Give three causes of earthquakes (3 mks)
5. The table below represents rainfall and temperature figures for a town in Africa. Use it to answer the questions that follow

Month	J	F	M	A	M	J	J	A	S	O	N	D
Temp (°C)	27	28	28	28	27	25	25	24	25	26	27	26
Rainfall (mm)	25	38	99	140	277	439	277	69	142	201	71	25

- (a) (i) calculate the annual range of temperature for the town (1 mk)

SECTION B

Answer question 6 and any other two questions from this section

6. Study the map of Nyahururu, 1: 50,000 (sheet 105/4) provided and answer the following questions
- (a) (i) Give the six figure grid of the junction where the road to Ndaragwa (D 388) meets with the road to Nyeri & Nanyuki (B5) (2 mks)
 (ii) Calculate the bearing of point X from point Y (2mks)
 (iii) Name three physical features found along the line XY (3mks)
- (b) (i) Draw a square 12 cm by 12 cm to represent the area enclosed by the Easting 10 and northing 10 to the North-eastern part of the map (1 mk)
 (ii) On the square, mark and label
- The main river (1 mk)

- All weather loose surface road (1 mk)
- A forest (1 mk)

- (b) Citing evidence from the map, explain two
- (i) Physical factors that may have influenced the location of Nyahururu town (4 mks)
 - (ii) Factors that favour saw milling in the area covered by the map (4 mks)

4. The diagram below shows river Manderu. Use it to answer question (a)

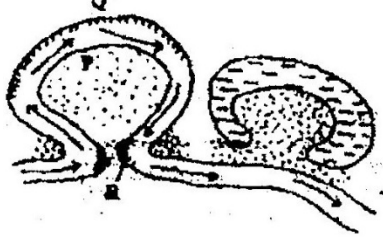

- (a)
 - (i) Name the process that take place at each of the points marked P and Q. (2mks)
 - (ii) Name the feature formed at the point marked R (1mk)
 - (iii) Describe how an Ox-bow lake is formed (5 mks)
- (b) State five characteristics of a flood plain (5 mks)
- (c) Explain three causes of river rejuvenation (6 mks)
- (c) Your class is required to carry out a field study of a river
 - (i) What would be the advantages of dividing the class into groups according to the stages of the long profile of a river?(4mks)
 - (ii) What would be the disadvantage of using secondary data in this kind of a field study? (2mks)

8. (a)
 - (i) What is an ice sheet? (2mks)
 - (ii) Give two reasons why there are no ice sheets in Kenya (2mks)
 - (iii) Explain three factors that influence the movement of the ice from the place where it has accumulated (6mks)
- (b) Describe how an arête is formed (4mks)
- (b) The diagram below shows types of moraines in a valley glacier

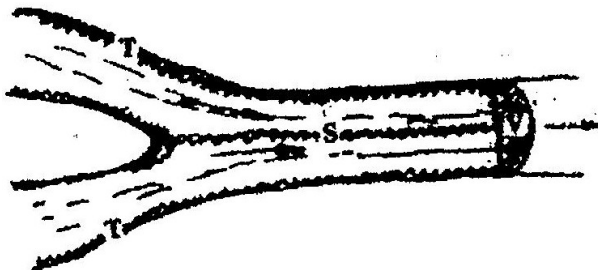

- (i) Name the type of moraines marked S, T and V (3mks)
- (ii) Explain four positive effects of glaciation in lowland areas. (8mks)

9. The diagram below represents zones of natural vegetation on a mountain in Africa. Use it to answer question (a) (i) and (ii)

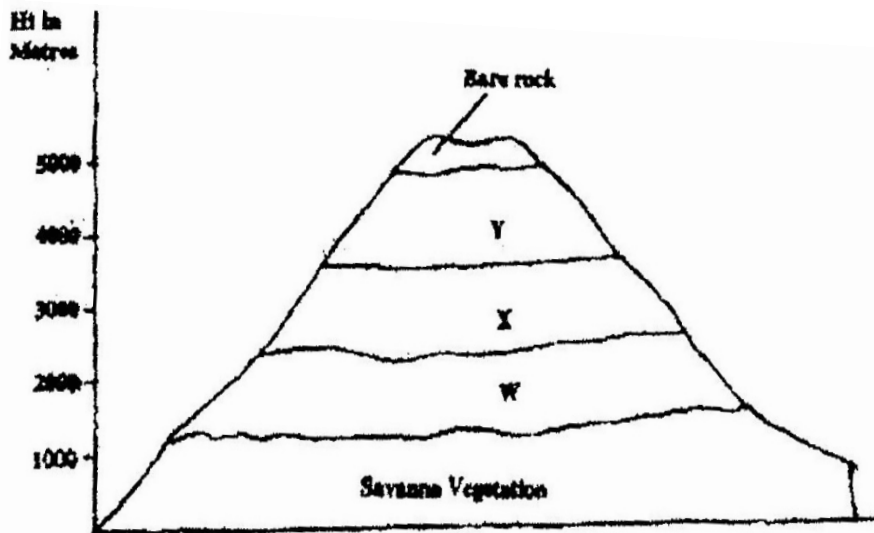

- a)
 - (i) Name the vegetation zones marked W, X and Y. (3mks)
 - (ii) Describe the characteristics of the savanna vegetation. (6mks)
 - (iii) Name the temperate grasslands found in the following countries:
 - Canada (1mk)
 - Russia (1mk)
 - Australia (1mk)
 - b) Explain three causes of the decline of the areas under forest in Kenya. (6mks)
 - c) You are supposed to carry out a field study on the uses of vegetation in the area your school.
 - (i) State three reasons why it would be necessary to visit the area before the day of the study. (3mks)
 - (ii) Give four uses of you are likely to identify during the study (4mks)
10. a)
 - (i) What is soil catena?
 - (ii) Draw a labeled diagram to show a well developed soil profile. (5mks)
 - (iii) State three characteristics of the soils found in the arid regions of Kenya. (3mks)
 b) Give three factors that determine the colour of soil.

- c) Describe how laterization occurs. (6mks)
- d) Explain how the following farming practices cause soil erosion. (2mks)
- (i) Burning
 - (ii) Continuous application of fertilizer on farm lands. (2mks)
 - (iii) Monocultures. (2mks)

GEOGRAPHY
PAPER 1
2007
2³/₄ HOURS
Oct / Nov.

SECTION A

Answer all the questions in this section

1. (a) State two effects of the rotation of the earth (2 mks)
- (b) Study the diagram below and answer the questions that follow

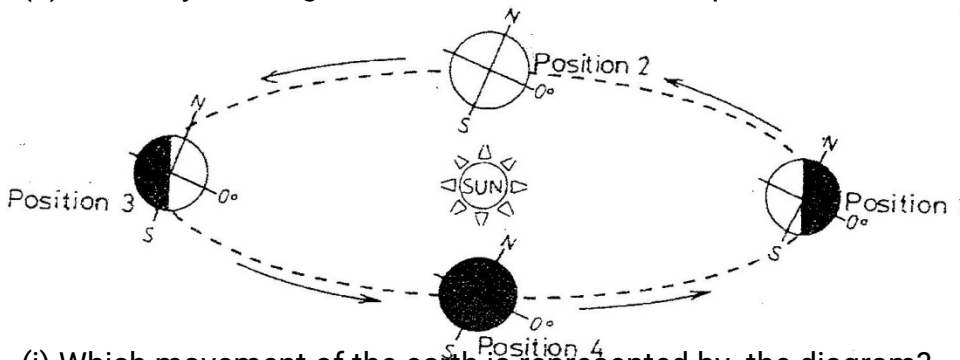

- (i) Which movement of the earth is represented by the diagram? (1 mk)
- (ii) Give two effects of the movement represented by the diagram (2 mks)
2. (a) name two types of the coastal deltas (2 mks)
- (b) State two conditions that lead to deposition of silt at the mouth of a river (2 mks)
3. The diagram below represents a barchan. Use it to answer questions (a)

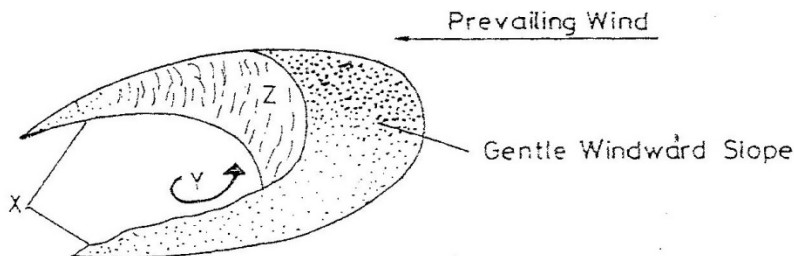

- (a) Name

- (i) the feature marked X (1mk)
- (ii) The air current marked Y (1mk)
- (iii) The slope marked Z (1 mk)

(b) Give two ways in which wind transports its load (2mks)

4. The diagram below represents the structure of the earth. Use it to answer question

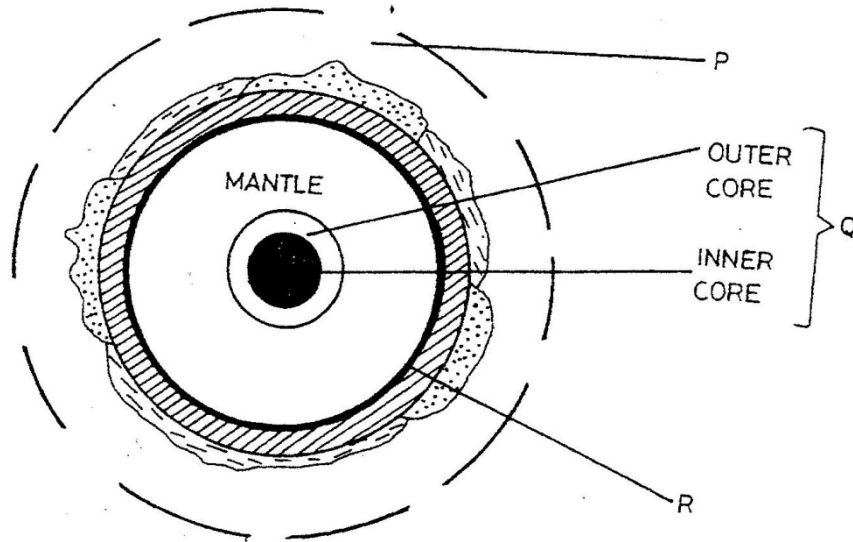

(a) Name

- (i) The parts marked P and Q (2mks)
- (ii) The discontinuity marked R (1 mk)

(b) State three characteristics of the mantle (3 mks)

5. (a) Name the two types of earth movements that occur within the earth's crust (2 mks)

(b) Describe the origin of the continents according to the Theory of continental Drift (3 mks)

SECTION B

Answer questions 6 and any other two questions in this following

6. Study the map of Taita Hills (1:50,000) sheet 189/4 provided and answer the following questions

- (a) (i) What is the bearing of the peak of Mwatunga hill in grid square 3214 from the water tank in grid square 2619? (2 mks)
- (ii) What is the length in kilometers of the section of the Mwatate – Voi railway line in the south – eastern part of the map? (2mks)

(b) Draw a rectangle measuring 16cm by 12 cm to represents the area enclosed by the Eastings 24 and 40 and Northings 20 and 30 (1 mk)

On the rectangle, mark and name the following features:

- Mgange hills (1 mk)
- A rock out crop (1 mk)
- All weather road, bound surface (1 mk)
- River Ruhia (1 mk)
- Ronge forest (1 mk)

(c) Using evidence from the map, explain three factors that have favoured the establishment of the Teita sisal Estates in the Southern part of the area covered by the map (6 mks)

(d) (i) Describe the distribution of settlement in the area covered by the map (5mks)

(ii) Citing evidence from the map, give two economic activities carried out in the area covered by the map other than sisal farming (4mks)

7. (a) Describe the following characteristics of minerals

- (i) Colour (2mks)
- (ii) Cleavage (2mks)
- (iii) Hardness (2mks)

(b) (i) Give two types of igneous rocks (2mks)
 (ii) Explain three conditions necessary for the growth of coral polyps (6mks)

(c) State four uses of rocks (4mks)

(d) You are planning to carry out a field study on the rocks within your school environment

(i) Give two secondary sources of information you would use to prepare for the field study (2mks)

(ii) State why you would need the following items during the field study:
 ▪ A fork jembe (1mk)
 ▪ A polythene bag (1mk)

(iii) Suppose during the field study you collected marble, sandstone and granite, classify each of these samples according to its mode of formation (3mks)

8. (a) (i) What is climate? (2mks)

(ii) Explain two effects of climate change on the physical environment (4mks)

(b) The table below shows rainfall and temperature figures of station in Africa

Month	J	F	M	A	M	J	J	A	S	O	N	D
-------	---	---	---	---	---	---	---	---	---	---	---	---

Temp in °C	24	24	23	22	19	17	17	18	19	20	22	23
Rainfall in mm	109	122	130	76	52	34	28	38	70	108	121	120

- (i) On the graph paper provided, draw a bar graph to represent the rainfall figure.
(Use a vertical scale of 1 cm to represent 10mm) (5mks)
- (ii) Describe the rainfall pattern of the station (4mks)
- (iii) Calculate the average monthly temperature for the station (Show your calculations) (2mks)
- (c) You are supposed to carry out study on the weather within your school compound
- (i) Describe how you would use the following instruments during the field study
- The hygrometer (3 mks)
 - The rain gauge (3 mks)
- (ii) State two ways in which the information collected during the field study would be useful to the local community (2 mks)
9. (a) Give three processes that lead to formation of lakes (3 mks)
- (b) (i) Describe how lake Victoria was formed (4 mks)
- (ii) Explain how lake Victoria influences the climate of the surrounding areas (6 mks)
- (c) (i) Apart from LakeMagadi name two other lakes within the rift valley in Kenya that have a high level of salinity (2 mks)
- (ii) Explain three causes of salinity in LakeMagadi (6 mks)
- (d) Give four economic uses of lakes other than mining (4 mks)
10. (a) (i) What is the difference between weathering and mass wasting?
- (ii) Apart from plants, give three other factors that influence the rate of weathering
- (iii) Explain two ways in which plants cause weathering (4mks)
- (b) (i) List two types of mass wasting other than soil creep (2mks)
- (ii) Explain three factors that cause soil creep. (6mks)
- (c) Explain four effects of mass wasting on the environment. (8mks)

GEOGRAPHY
 PAPER 1
 2008
 2 3/4 HOURS
 Oct / Nov.

SECTION A

Answer all the questions in this section

- 1 a) Give three reasons why it is necessary to study the plate tectonics theory. (3mks)
 b) Name two types of tectonic plate boundaries (2mks)
2. a) The diagram below shows a Six's Thermometer. Name the parts marked P, Q and R. (3mks)

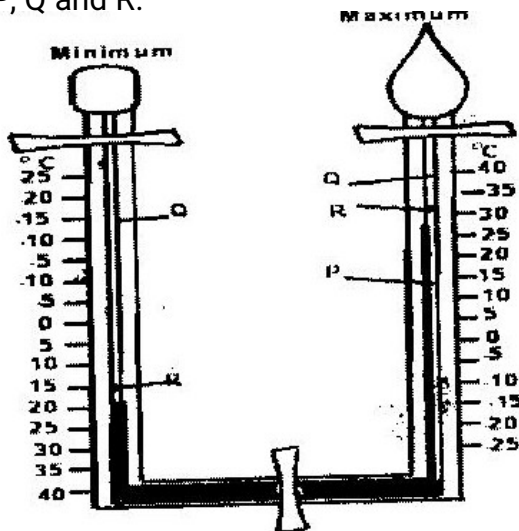

- b) The table below shows temperature readings at a weather station for one week

Temp/Day	Mon	Tue	Wed	Thur	Fri	Sat	Sun
Max. °C	28	27	28	29	29	29	26
Min. °C	18	18	20	16	22	21	19

Calculate the following:

- i) The diurnal range of temperature for Tuesday: (1mk)

3. a) Give two examples of non-metallic minerals. (2mks)
 b) Why is industrial diamond used in shaping hard stones and metals? (1mk)
4. a) Apart from water vapour, name two other substances that are suspended in the atmosphere.
 b) i) Give two factors that are considered when classifying clouds. (2mks)
 ii) Name two types of clouds that give rise to rainfall in the tropical regions. (2mks)

5. a) The diagram below shows an eclipse. Name the features marked V and W.

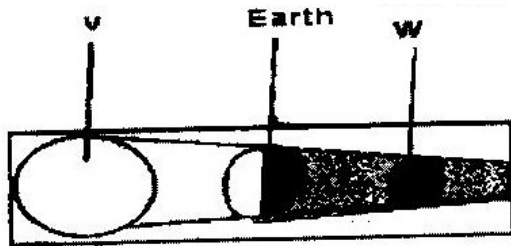

(2mks)

- b) State four proofs that the shape of the earth is spherical. (4mks)

SECTION B

Answer question 6 and any other Two questions from this section

6. a) Study the map of Kericho 1:50,000 provided and answer the following questions.
- i) Give the longitudinal extent of the area covered by the map. (1mk)
- ii) Convert the scale of the map into a statement scale. (2mks)
- iii) What is the approximate height of the hill in the grid square 6770? (2mks)
- iv) Calculate the area of Kericho Municipality. Give your answer in square kilometers. (2mks)
- b) i) Give three types of natural vegetation found to the west of Easting 53 (3mks)
- ii) What is the bearing of the trigonometrical station at grid reference 554668 from the factory at grid reference 610626? (2mks)
- iii) Identify three forms of land transport found to the north of Northing 68 and west of Easting 53? (3mks)
- c) Describe the distribution of settlements in the area covered by the map. (4mks)
- d) Citing evidence from the map, explain three factors that favour the

establishment of tea estates in the area covered by the map. (6mks)

7. a) Differentiate between magna and lava. (2mks)
b) The diagram below shows some intrusive volcanic features.

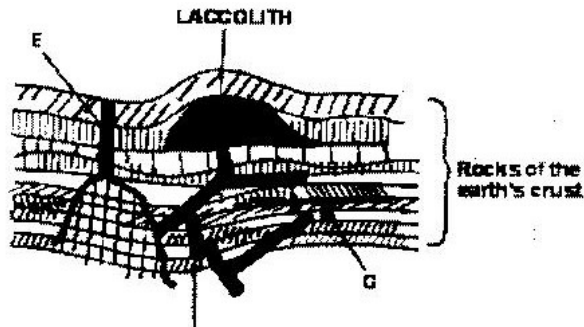

Name the features marked E, f and G. (3mks)

- c) Describe how the following features are formed and for each give an example from Kenya:
i) A crater (3mks)
ii) A geyser (5mks)
iii) A lava plateau (4mks)
d) Explain four ways in which volcanic features influence human activities. (8mks)

8. a) i) Name two sources of rivers. (2mks)
ii) The diagram below shows the three stages of the long profile of a river.

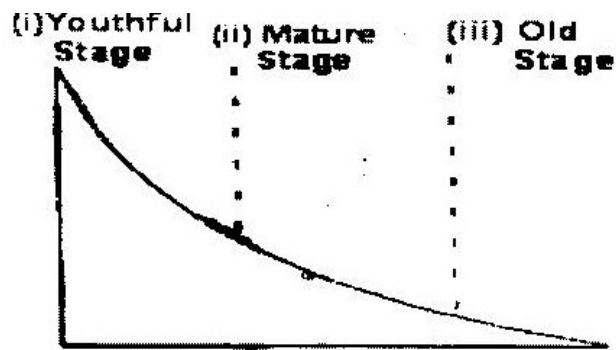

Give two features formed by the rivers in each of the three stages. (6mks)

- b) Describe the processes by which a river transports its load. (6mks)
c) Describe each of the following drainage patterns;
i) State two methods you would use to collect data. (3mks)
ii) State three advantages of studying the work of rivers through

9. a) fieldwork. (3mks)
- a) i) Describe how ice is formed on a high mountain. (3mks)
- ii) Apart from a valley glacier, name two types of ice masses found on Mountains in East Africa.
- b) Explain how the movement of a valley glacier is influenced by the following factors:
- i) Temperature (2mks)
- ii) Width of a glacier channel. (2mks)
- c) Describe the distinctive characteristics of the following features resulting from glacial erosion:
- i) A corrie (3mks)
- ii) A pyramidal peak (3mks)
- iii) a fiord (fjord) (3mks)
- d) i) The diagram below shows a glaciated upland area

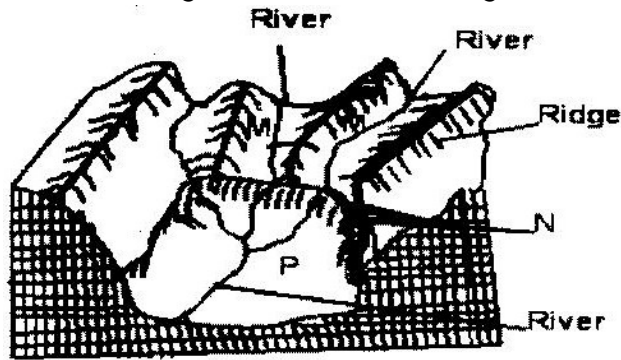

Name the features marked M, N, and P.

- ii) Describe the process through which a crag and tail is formed (4mks)

10. a) The diagram below shows a breaking sea wave.

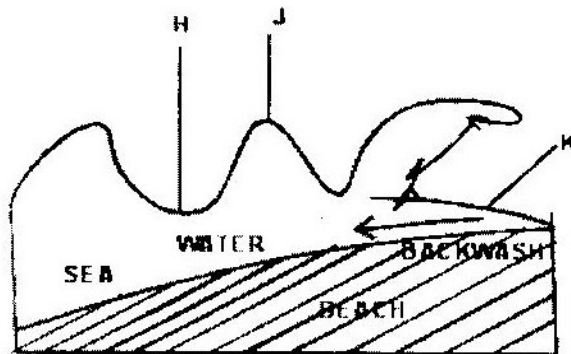

- i) Name the features marked M, N, and P.
- ii) Describe the process through which a crag and tail is formed.

- (4mks)
- b) Describe three processes of wave erosion along the coast. (2mks)
- c) Explain how the following factors influence wave deposition:
- i) Gradient of the shore (4mks)
 - ii) Depth of the sea (4mks)
- e) Using well labeled diagrams, describe how a bay bar is formed. (6mks)

SECTION A

Answer ALL the questions in this section

1. (a) Differentiate between the processes of the formation of plutonic rocks and volcanic rocks (2 mks)

(b) For each of the following sedimentary rocks, name the resultant rock that forms after metamorphism:

- (i) Sandstone
- (ii) Limestone
- (iii) Clay

2. Use the diagram below to answer the questions that follows

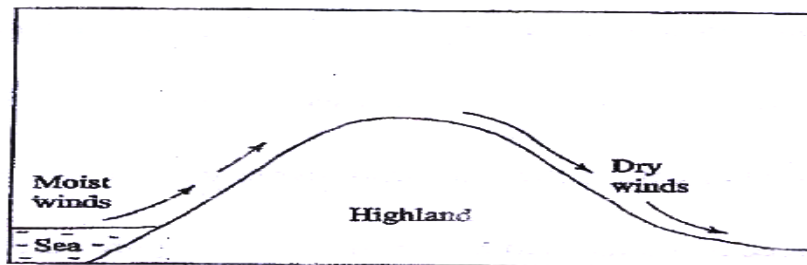

Outline the process through which the moist winds shown go through to eventually become dry winds (5 mks)

3. (a) What is a line of longitude? (2 mks)

(b) What is the local time at Alexandra 30°E when the local time at Malindi 40° E is 12.00 noon? (2 mks)

4. (a) Outline the steps followed when measuring humidity using a hygrometer

(3 mks)

(b) Give two factors that influence relative humidity (2 mks)

(2 mks)

5. The diagram below shows some types of folds. Use it to answer question

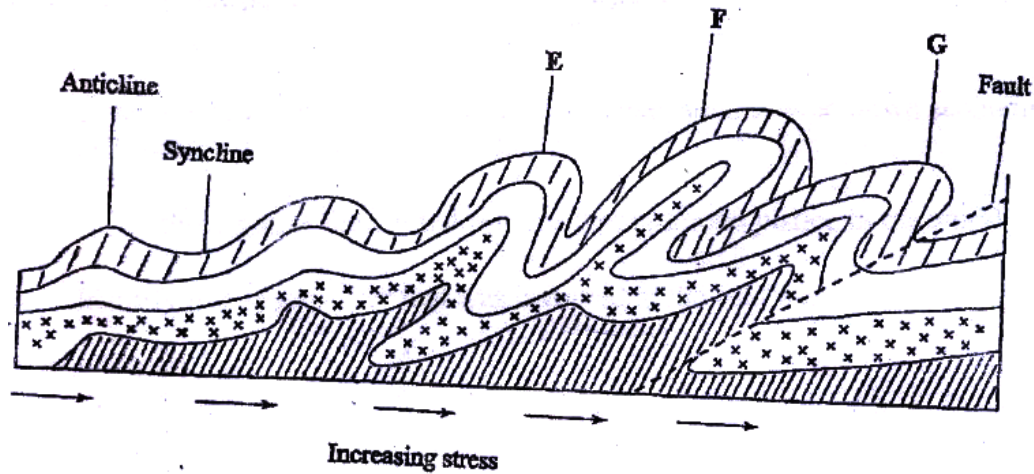

(a)

(a) Name the type of folds marked E, F, and G (3 mks)

(b) In which countries are the following fold mountains found?

(i) Andes (1 mk)

(ii) Cape Ranges (1 mk)

mk)

(iii) Alps (1 mk)

6. The diagram below shows a hydrological cycle.

(a) (i) What do the arrows labeled K, L, and M on the cycle represent? (3 mks)

(ii) Explain three factors that influence the occurrence of surface run-off (6 mks)

(b) (i) What is mass wasting? (2 mks)

(ii) Give two processes of slow mass movement (2 mks)

(iii) State two physical conditions that may influence landslides

For marking schemes, call/Whatsapp-0746711892.

- (c) Describe the following processes of mass wasting (2 mks)
- (i) Rock fall (2 mks)
 - (ii) Subsidence (2 mks)
 - (iii) Mud flows (2 mks)
- (d) Explain the effect of mass wasting on the following
- (i) Tourism (2 mks)
 - (ii) Soil fertility (2 mks)
7. (a) (i) Name three types of faults (3 mks)
- (ii) Apart from compressional forces, explain two other processes that may cause faulting (4 mks)
- (b) With the aid of diagrams, describe how compressional forces may have led to the formation of the great rift valley (8 mks)
- (c) Explain five ways in which faulting is of significance to human activities (10 mks)
8. (a) (i) Apart from Bird's Foot delta, name two other types of coastal deltas (2 mks)
- (ii) Draw a diagram to show a Bird's foot delta (3 mks)
 - (iii) Describe how a Bird's Foot delta is formed (4 mks)
- (b) Explain four factors that influence the development of coast (8 mks)
- (c) (i) Differentiate between a barrier reef and a fringing reef? (2 mks)
9. The diagram below represents some coastal features. Name the features marked P, Q and R (3 mks)

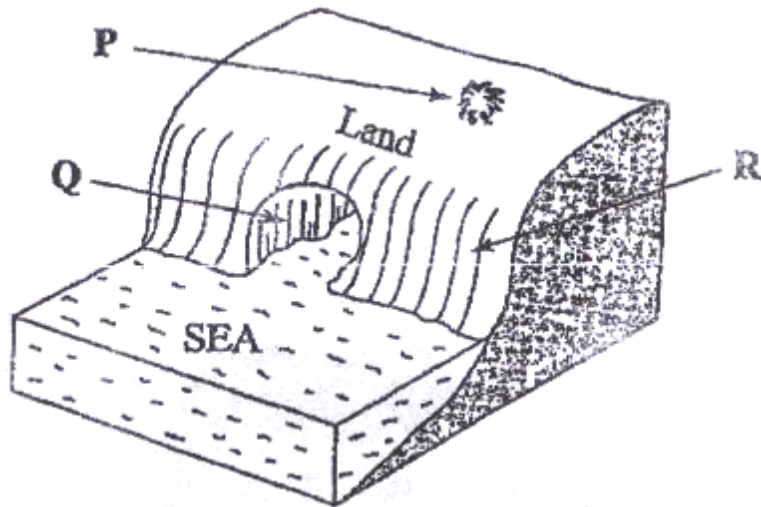

(iii) State

three conditions necessary for the formation of a beach

(3 mks)

10. The diagram below represents underground features in a limestone area. Use it to answer question (a)

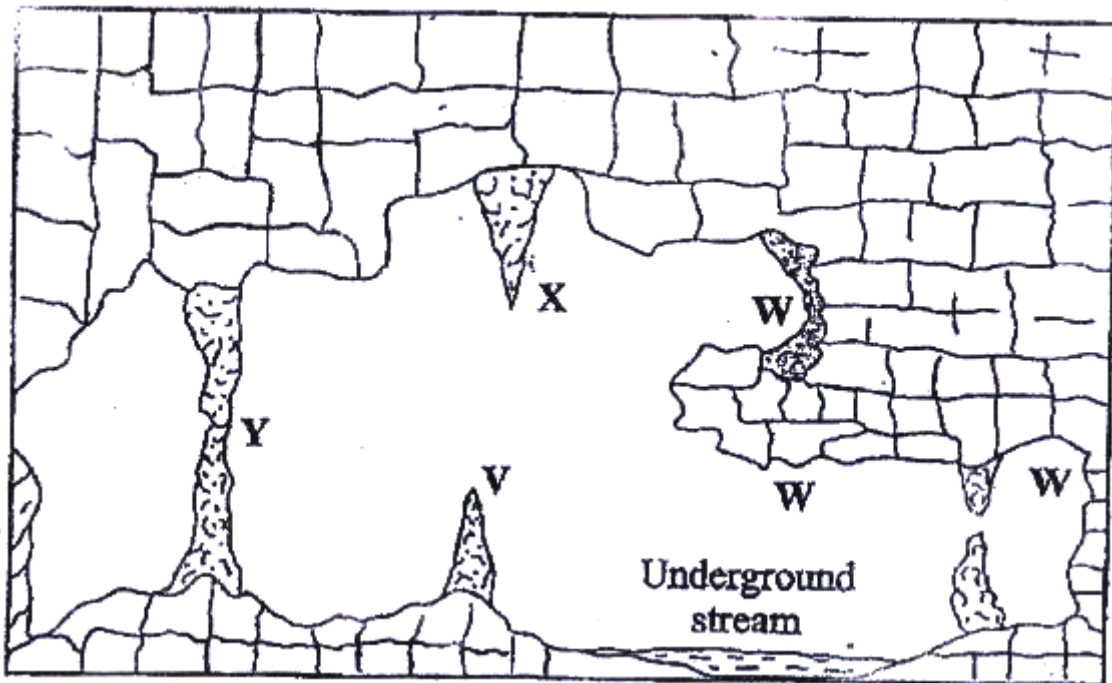

(a) (i) Name the features marked X, V and W

(3

mks)

(ii) Describe how the feature marked Y is formed

(6

mks)

For marking schemes, call/Whatsapp-0746711892.

- (b) (i) What is an artesian basin? (2 mks)
(ii) Explain three factors which influence the formation of features in limestone areas (6 mks)
- (c) You are supposed to carry out a field study of an area eroded by water
(i) Give three reasons why you would need a map of the area of study (3 mks)
(ii) Name two erosion features you are likely to identify during the field study (2 mks)
(iii) State three recommendations that you would make from your study to assist the local community to rehabilitate the eroded area (3 mks)

**GEOGRAPHY
PAPER 1
2010
2 ³/₄ HOURS
Oct / Nov.**

SECTION A

Answer ALL the questions in this section.

- 1 Give **three** components of the solar system. (3 marks)
- 2 (a) Identify **two** types of high level clouds. (2 marks)
(b) Draw a well labeled diagram of a hydrological cycle. (5 marks)
- 3 (a) Give **three** causes of earthquakes. (3 marks)

For marking schemes, call/Whatsapp-0746711892.

marks)

(b) Name two major earthquake zones of the world.

(2 marks)

4 (a) What is a rock?

(2

mark)

(b) Give **three** characteristics of sedimentary rocks.

(3 marks)

5 (a) The diagram below shows some coastal features

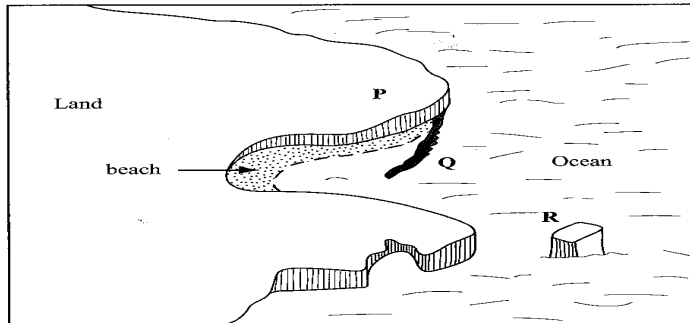

Name the features marked P, Q and R.

(3 marks)

(b) State **two** conditions necessary for the formation of a beach.

(2 marks)

SECTION B

Answer question 6 and any other TWO questions from this section.

6. Study the map of Homa Bay (1:50,000) sheet 129/2 provided and answer the following questions.

(a) A pipeline is to be laid from Lake Victoria along the line marked X-Y.

(i) What is the length of the piping to be used?

(Give your answer to the nearest 100 metres).

(2 marks)

(ii) Calculate the bearing of point Y from point X

(2 marks)

(iii) Calculate the area of the part of Lake Victoria shown on the map excluding

the marshy sections. (Give your answer in square kilometers).

(2 marks)

(b) The rectangle below represents the area in the map extract bounded by Eastings 54 and 60 and Northings 35 and 40. Identify and name the features marked J, K, L and M.

(4 marks)

For marking schemes, call/Whatsapp-0746711892.

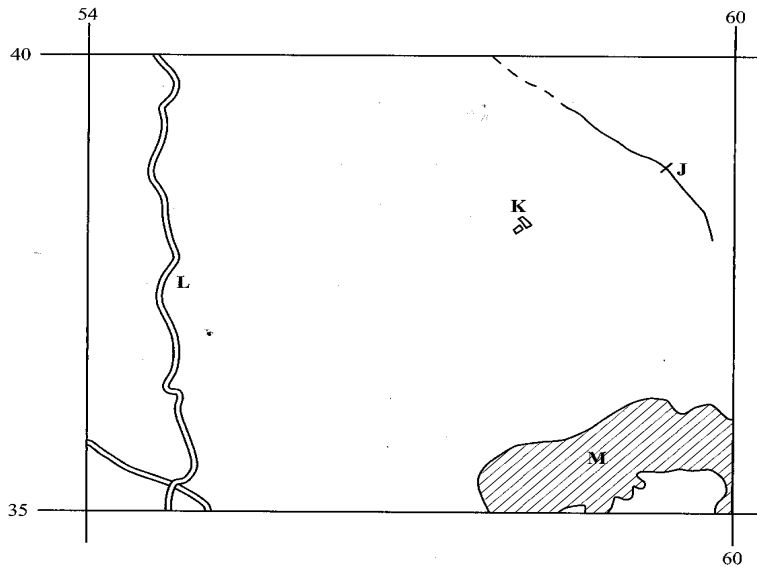

- (c) (i) Explain **three** factors which have influenced the distribution of settlements in the area covered by the map. (6 marks)
- (ii) Citing evidence from the map, give **two** agricultural activities carried out in the area covered by the map. (4 marks)
- (d) Describe the drainage of the area covered by the map. (5 marks)

7. The map below shows some vegetation regions of the world. Use it to answer questions (a) and (b). Coniferous forest

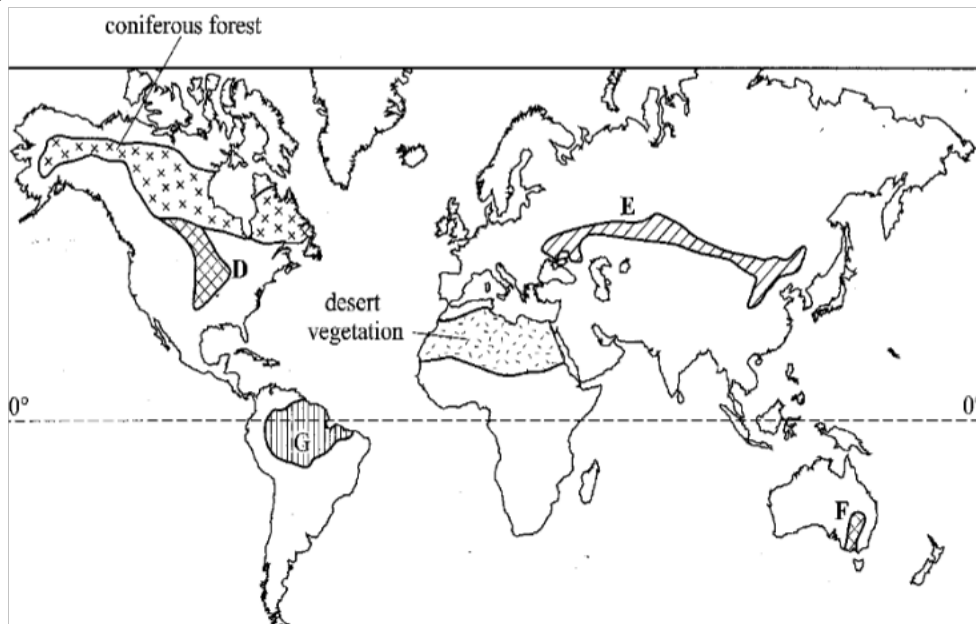

- (a) (i) Name the temperate grasslands marked D, E and F. (3)

marks)

(ii) Describe the characteristics of the natural vegetation found in the shaded area marked G. (6

marks)

(b) Explain how climate has influenced the existence of the following types of vegetation shown on the map.

(i) Desert vegetation; (4

marks)

(ii) Coniferous forest. (4 marks)

(c) You are required to carry out a field study of the natural vegetation within your local environment.

(i) Apart from identifying the different types of plants, state **three** other activities you would carry out during the field study.

(3 marks)

(ii) How would you identify the different types of plants? (3

marks)

(iii) State **two** ways in which the information collected during the field study would be useful to the local community.

(2 marks)

8. (a) Describe plucking as a process in glacial erosion. (4

marks)

(b) Explain **three** conditions that lead to glacial deposition. (6

marks)

(c) The diagram below shows features resulting from glacial deposition on a lowland area.

Direction of movement of ice

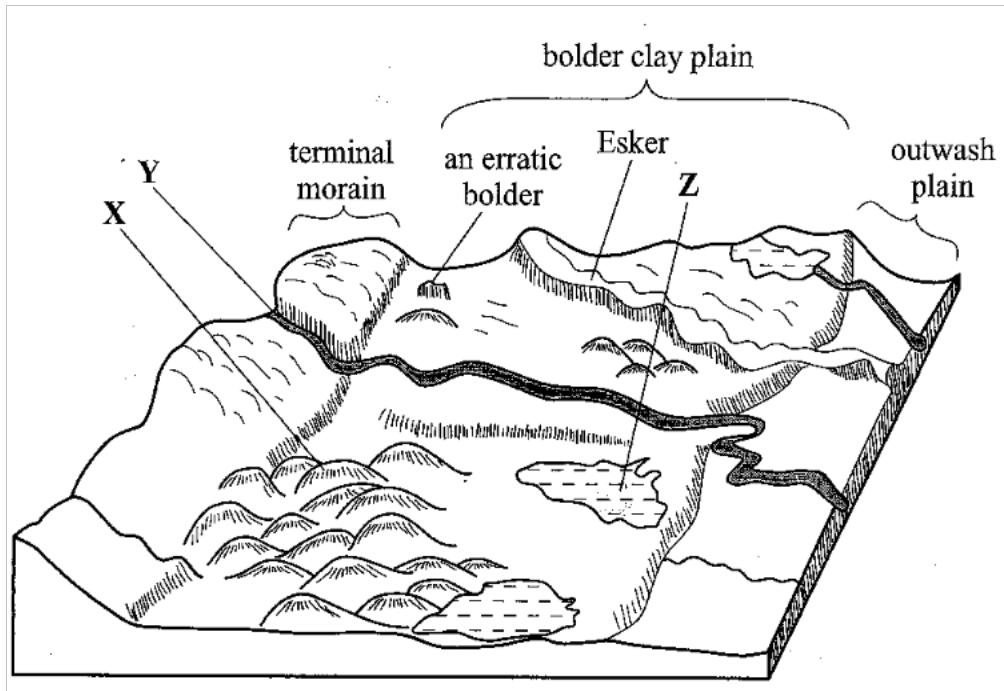

- (i) Name the features marked X, Y and Z. (3 marks)
- (ii) Describe how terminal moraine is formed. (4 marks)
- (d) Explain **four** positive effects of glaciation in lowland areas. (8 marks)

9. (a) Differentiate between river rejuvenation and river capture. (2 marks)
- (b) Give **three** features resulting from;
- (i) river rejuvenation; (3 marks)
 - (ii) river capture. (3 marks)
- (c) Explain the **four** ways through which a river transports its load. (8 marks)
- (d) You are planning to carry out a field study on the lower course of a river.
- (i) Give **three** reasons why you would require a route map. (3 marks)
 - (ii) State three characteristics of a river at the old stage that you are likely to observe during the field study. (3 marks)
 - (iii) Give **three** follow-up activities you would be involved in after the field study.

(3 marks)

10 The diagram below represents a well developed soil profile. Use it to answer question (a).

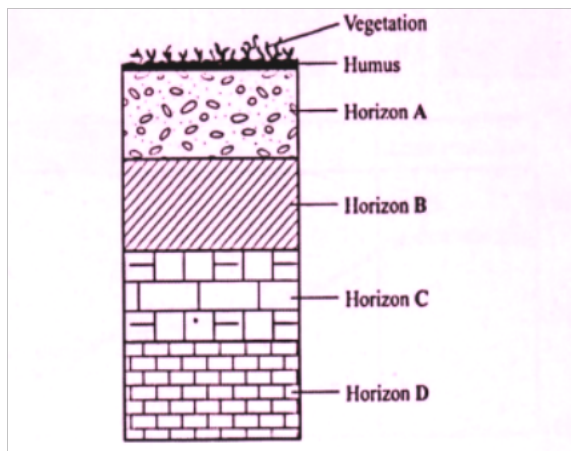

- (a) (i) Describe the characteristics of horizon B. (3 marks)
- (ii) Apart from humus, name **three** other components of soil. (3 marks)
- (iii) State **three** ways in which humus contributes to the quality of soil. (3 marks)
- (b) (i) Differentiate between soil structure and soil texture. (2 marks)

marks)

- (ii) Explain how the following factors influence the formation of soil;
- topography; (6 marks)
 - time. (2 marks)
- (c) Explain how the following farming practices may lead to loss of soil fertility:
- (i) overgrazing; (2 marks)
 - (ii) frequent ploughing; (2 marks)
 - (iii) continuous irrigation. (2 marks)

GEOGRAPHY
PAPER 1
2011
2 ³/₄ HOURS
Oct / Nov.

SECTION A

Answer ALL the questions in this section.

1. The diagram below shows the angles of the sun's rays at different latitudes when the sun is at the equator. Use it to answer questions (a) and (b).

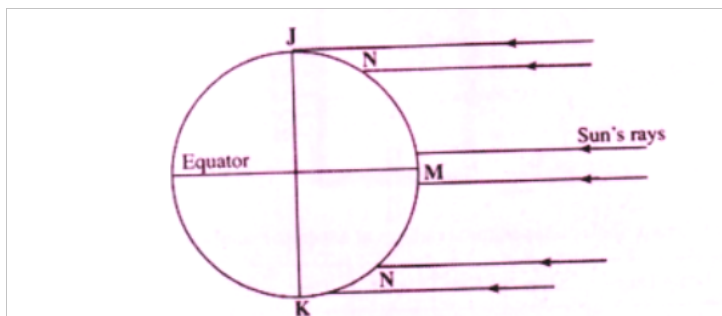

- (a) Name the parts of the earth's surface marked J and K. (2 marks)
- (b) Give **two** reasons why the intensity of the insolation is higher at M than at N. (2marks)
2. (a) What is weathering? (2marks)

- (b) Give **three** factors that influence the rate of weathering. The diagram below shows a composite volcano. (2marks)

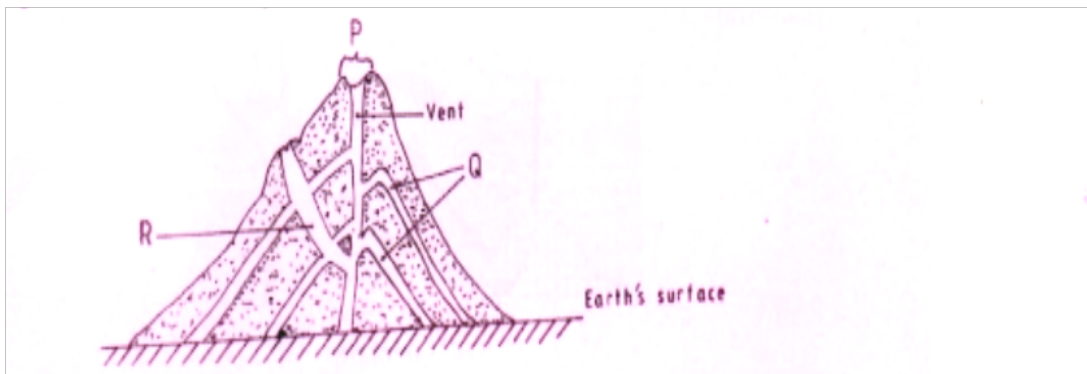

3. (a) Name the features marked P, Q and R. (3 marks)
 (b) How is a parasitic cone formed?
4. (a) What is land breeze? (2 marks)
 (b) Give two ways in which sea breezes influence the adjacent land. (2 marks)
5. The diagram below shows ways through which wind transports its load.

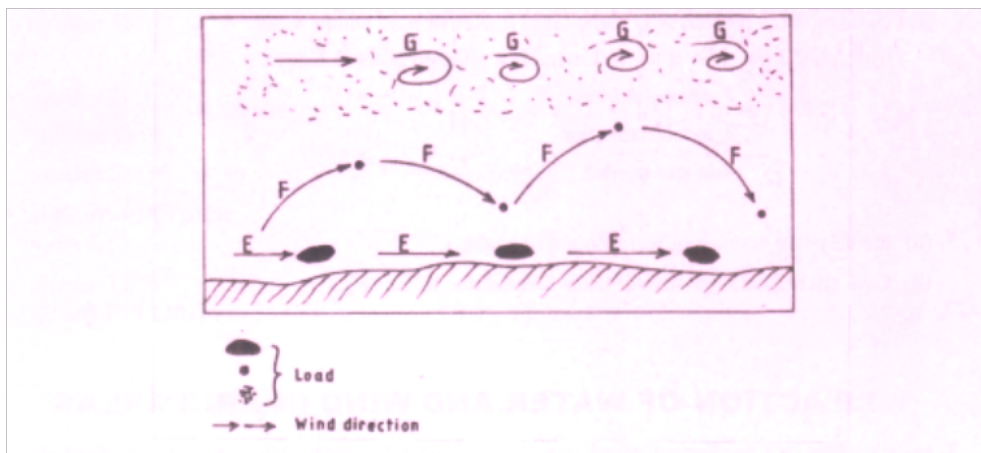

- (a) Name the **three** ways labelled E, F and G. (3 marks)
 (b) Name **three** features produced by wind abrasion in arid areas. (3)

marks)

SECTION B

*Answer question 6 and any two other questions from this section,
Study the map of Nkubu (1:50,000) sheet 122/1 provided and answer the following questions.*

6. (a) (i) Give the latitudinal and longitudinal position of the North East corner of the map extract
(2 marks)
(ii) Give **two** methods used to represent relief on the map.
(2 marks)
(iii) What is the relief feature found, at the top of Kirui Hill within Mt. Kenya forest.

(1 mark)

- (iv) Apart from administration, give **three** other services that are provided at Nkubu

Divisional Headquarters. (3 marks)

- (b) (i) What is the length in kilometers of the all-weather bound surface road from the bridge at Nkubu water works (509935) to the road junction near Gitimbi (509995)? (2 marks)

- (ii) State **three** problems that may be encountered during construction of roads

in

the area covered by the map.. (3 marks)

- (c) Citing evidence from the map, give **three** reasons why cattle rearing is widespread in

Nkubu area. (6 marks)

- (d) Describe the drainage of the area covered by the map. (6 marks)

7. (a) (i) State **three** conditions that are necessary for siting a weather station. (3 marks)

- (ii) Give **four** reasons why weather forecasting is important. (4 marks)

- (b) The table below shows the temperature and rainfall figures for a weather station in Kenya. Use it to answer question (b) and (c).

Month	J	F	M	A	M	J	J	A	S	O	N	D
-------	---	---	---	---	---	---	---	---	---	---	---	---

Mean monthly temperature in	16.2	16.5	17.1	17.1	16.1	15.2	15.2	15.0	16.0	16.1	16.1	16.3
Rainfall 2 125 mm	100	104	175	232	323	218	196.	231	196	152	127	71

Source: Kenya Meteorological Department

Calculate:

- (i) The mean annual temperature for the station. (2 marks)
- (ii) The annual range of temperature for the station. (2 marks)
- (c) (i) On the graph paper provided, draw a bar graph to represent the rainfall figures for the station. Use a vertical scale of 1cm to represent 20mm. (5 marks)
- (ii) Describe the characteristics of the climate experienced at the weather station.
- (d) Suppose you visited a weather station for a field study on weather;
- (i) Give **three** methods you would use to collect data. (3 marks)
- (ii) State **three** advantages of studying weather through fieldwork. (3 marks)

8. The map below shows the location of some mountain ranges.



(a) Name the ranges marked P, Q, R and S. (4 marks)

(b) (i) Apart from fold mountains, name **three** other features resulting from folding. (3 marks)

(ii) With the aid of labeled diagrams, describe how Fold Mountains are formed. (10 marks)

(c) Explain the significance of Fold Mountains to human activities. (8 marks).

9. (a) (i) what are tides? (2 marks)

(ii) Give **three** causes of ocean currents. (3 marks)

(iii) Name the **three** ocean currents along the western coast of Africa. (3 marks)

(b) (i) State **three** characteristics of submerged lowland coasts. (3 marks)

(ii) Explain **three** factors that determine the rate of coastal erosion. (6 marks)

(c) With the aid of labelled diagrams, describe the process through which a stack is formed. (8 marks)

10 (a) (i) What is a lake? (2 marks)

- (ii) Name two crater lakes in Kenya. (2 marks)
- (b) Describe how the following lakes are formed.
- (i) corrie lake (4marks)
- (ii) oasis (4marks)
- (iii) lagoon (4marks)
- (c) (i) **Give three** reasons why some lakes in Kenya have saline water. (3 marks)
- (ii) Explain how each of the following has affected lakes in Kenya:
- Deforestation (2 marks)
 - Industrialization (2 marks)
 - Water needs. (2 marks)

GEOGRAPHY
PAPER 1
2012
2 ³/₄ HOURS
Oct / Nov.

SECTION A

Answer all the questions in this section.

1. (a) What is the relationship between Geography and Mathematics? (2 marks)
- (b) State four reasons why it is important to study Geography. (4 marks)

2. (a) Name the two layers of discontinuity that are part of the interior structure of earth. (2 marks)
- (b) State **three** characteristics of the outer core in the interior structure of the earth. (3 marks)

3. (a) Name **two** forms of precipitation that commonly occur in Kenya. (2 marks)
- (b) What is a Stevenson's screen? (2 marks)

4. (a) Identity two causes of earth movement. (2 marks)

5. The diagram below shows some features formed as a result of faulting.

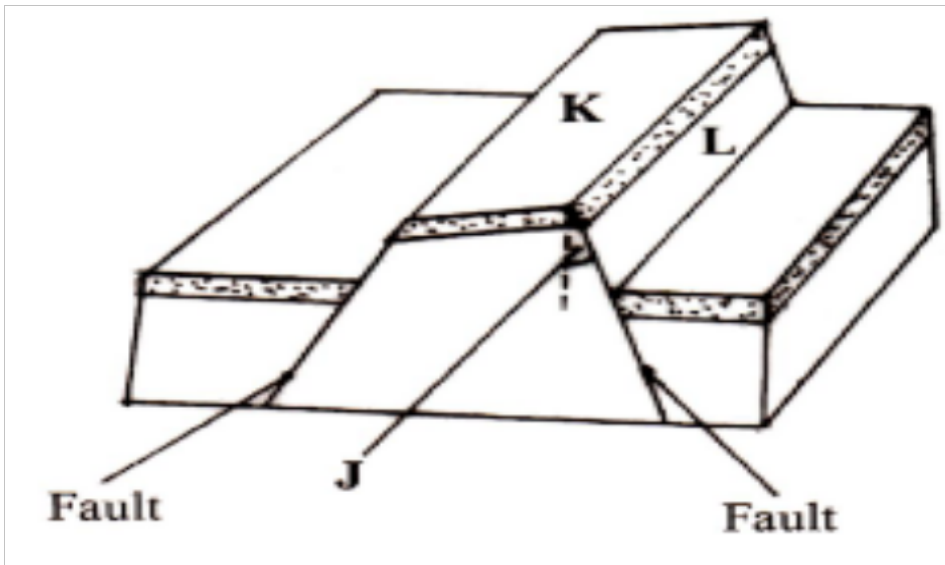

- (b) Identify:
- (i) the angle marked J. (1 mark)
- (ii) the features marked K and L. (2 marks)
- (a) Identify two sources of water found in a lake. (3 marks)
- (b) Give **three** characteristics of lakes formed due to faulting (2 marks)

SECTION B

Answer question 6 and any other two questions from this section.

6. Study the map of Kitale 1:50,000 (sheet 75/3) provided and answer the following questions.
- (a) (i) Identify the two human made features found at the grid square 2320. (2 marks)
- (ii) What is the altitude of the highest point in the area covered by the map? (2 marks)
- (iii) Give **three** types of natural vegetation found in the area covered by the map (3 marks)
- (b) (i) What is the bearing of the Air Photo Principal Point at grid square 3426 from the Air Photo Principal Point at grid square 2931? (2 marks)
- (ii) Measure the distance of the dry weather road (C 640) from the junction at point M (345142) to the junction at point N (416201). Give your answer in Kilometers. (2 marks)
- (c) (i) Using a scale of 1 cm to represent 40 metres, draw a cross section from grid reference 410180 to grid reference 500180. (4 marks)
- (ii) On the cross-section, mark and name the following:
- a dry weather road; (1 mark)
 - River Kaptarit; (1 mark)

mark) • a ridge. (1

(iii) Calculate the vertical exaggeration (VE) of the section. (2 marks)

(d) Citing evidence from the map, identify five social services offered in Kitale Municipality. (5 marks)

7. (i) What is a mineral? (2 marks)

(ii) Describe the following characteristics of minerals:

• lustre; (2 marks)

• colour; (2 marks)

• density. (2 marks)

(b) (i) Name **two** examples of extrusive igneous rocks. (2 marks)

(ii) Describe **three** ways in which sedimentary rocks are formed. (9 marks)

(c) Explain the significance of rocks to the economy of Kenya under the following subheadings:

(i) tourism; (2 marks)

(ii) energy; (2 marks)

(iii) water. (2 marks)

8.(a Explain the following processes of weathering:
)

(i) hydration; (2 marks)

- (ii) oxidation; (2 marks)
- (iii) frost action. (3 marks)
- (b) Describe how an exfoliation dome is formed. (6 marks)
- (c) Explain three physical factors that enhance movement of materials along a slope due to gravity. (6 marks)
- (d) (i) Give **two** processes of rapid mass movement. (2 marks)
- (ii) State **four** indicators of occurrence of soil creep in an area. (4 marks)
9. (a) (i) Outline **two** factors that influence the development of drainage patterns. (2 marks)
- (ii) Outline **five** characteristics of a river in its youthful stage. (5 marks)
- (b) Describe the following processes of river erosion:
- (i) attrition; (2 marks)
- (ii) corrasion. (4 marks)
- (c) Explain **three** negative effects of rivers to the human environment.
- (d) Your class is planning to carry out a field study of a river in its old stage. (3 marks)
- (i) State **three** reasons why it would be necessary to pre-visit the area of study. (3 marks)

GEOGRAPHY
PAPER 1
2013
2 ³/₄ HOURS
Oct / Nov.

SECTION A
Answer all the questions in this section

1. The diagram below represents the structure of the atmosphere. Use it to answer question (a)

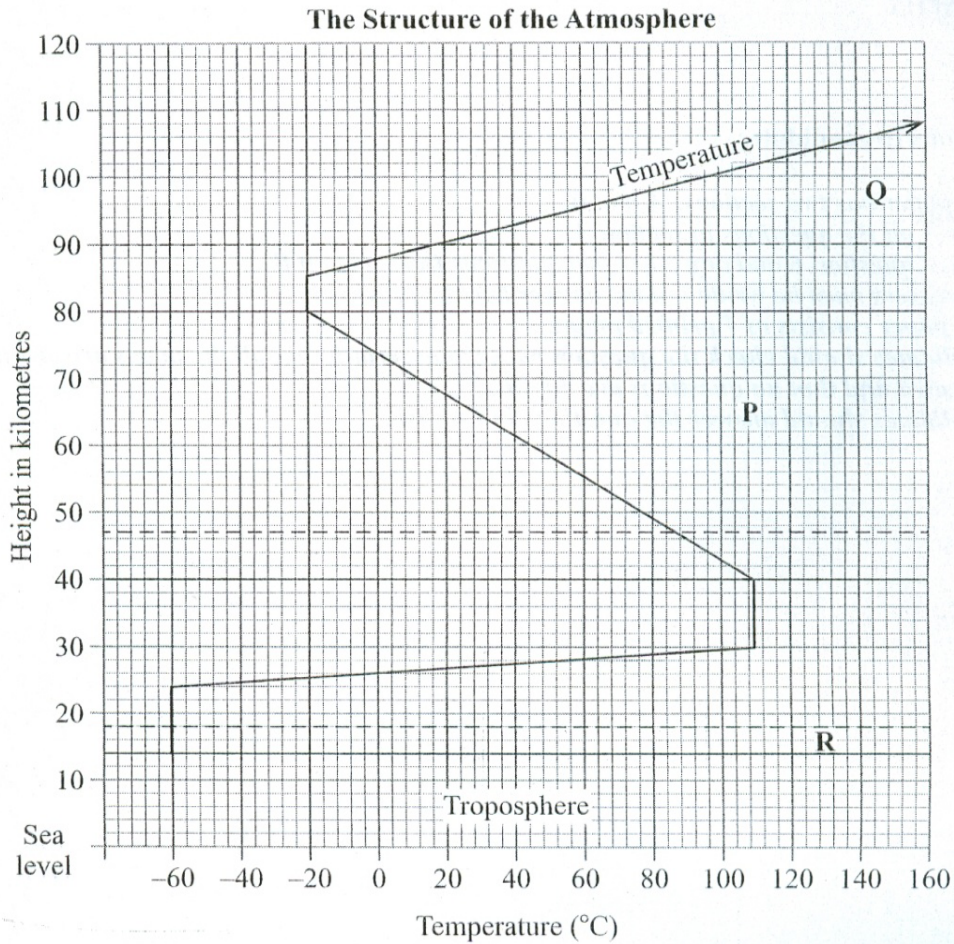

(a) Name

(i) The parts marked **P** and **Q** (2 marks)

(ii) The layer of discontinuity marked **R** (1 mark)

(b) State **two** characteristics of the weather conditions in the troposphere (2 marks)

2. State **five** factors that influence mass wasting (5 marks)

3. The diagram below shows a section of a river. Use it to answer the questions that follow

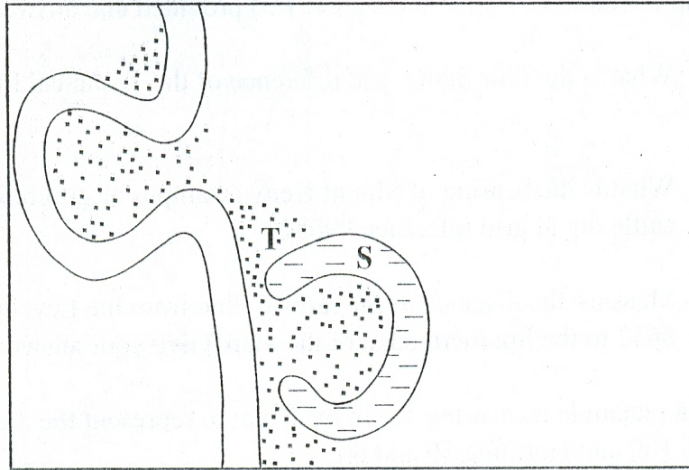

- (a) Name the features marked **S** and **T** (2 marks)
- (b) State **three** conditions that are necessary for the formation of the feature marked **S** (3 marks)
4. (a) What is the difference between an ice sheet and an iceberg (2 marks)
- (b) Name **three** types of glacial moraines (3 marks)
5. (a) Give **two** types of soil degeneration (2 marks)
- (b) State **three** economic benefits of soil (3 marks)

SECTION B

Answer question 6 and any other two questions from this section

6. Study the map of Karatina 1:50,000 (sheet 121/3) provided and answer the following questions.

(a) (i) What is the four grid reference of the technical institute at Mathira? (2 marks)

(ii) What is the bearing of Mount Kenya campus at grid reference 932568 from the cattle dip at grid reference 990529? (2 marks)

(iii) Measure the distance of the railway line from the level crossing at grid square 8652 to the southern edge of the map. Give your answer in kilometers (2 marks)

(b) Draw a rectangle measuring 15cm by 10cm to represent the area enclosed by Eastings

90 and 100 and Northing 50 and 60 (1 mark)

On the rectangle mark and name the following

(i) Kirinyanga district

(ii) All weather road bound surface

(iii) Forest

(iv) Coffee factory (4 marks)

(c) Describe the distribution of the natural vegetation in the area covered by the map

(6 marks)

(d) Identify two social functions of Karatina town (2 marks)

(e) Citing evidence from the map, explain **three** factors that favors trading in the area

covered by the map (6 marks)

7. (a) Name the first two planets of the solar system (2 marks)

marks)

(b) Explain the origin of the earth according to the Nebula Cloud Theory (8 marks)

Use the map below to answer question (c)(i)

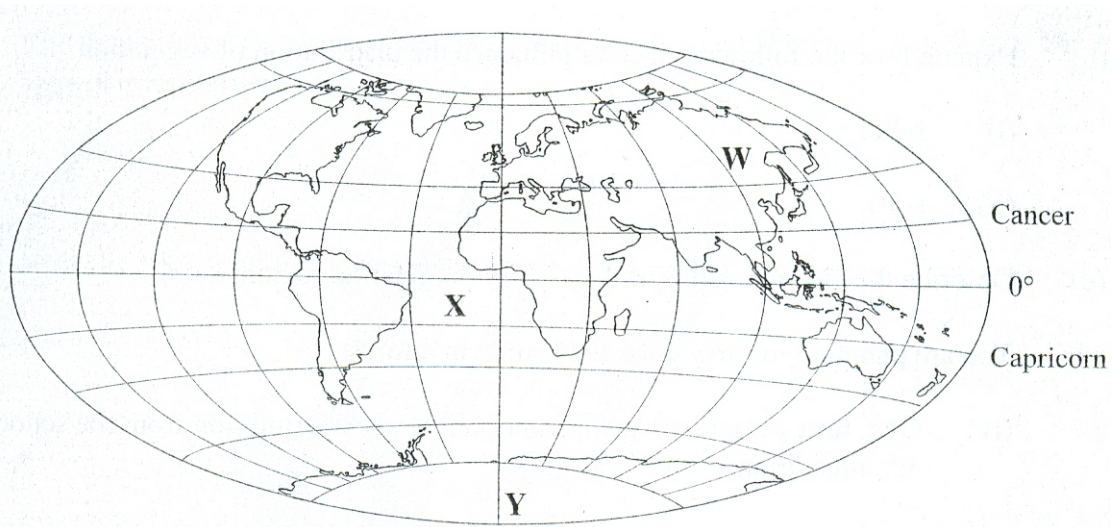

(c) (i) name

- The continent marked **W** (1 mark)
- The oceans marked **X** (1 mark)
- The line of longitude marked **Y** (1 mark)

(ii) Give **two** reasons why the earth has a spherical shape (4 marks)

(iii) State **four** effects of the rotation of the earth on its axis (4 marks)

(d) Describe the structure of the earth crust (4 marks)

8. (a) What is vulcanicity? (2 marks)

(b)(i) Apart from a sill, name **three** intrusive volcanic features (3 marks)

(ii) Describe how the following features are formed

- A sill (3 marks)
- Hot spring (5 marks)

- A caldera (4 marks)

(c) Explain **four** negative effects of earth quakes (8 marks)

9. (a) what is vegetation: (2 marks)

(b) Explain how the following factors influence the distribution of vegetation

(i) Relief (2 marks)

(ii) Soils (4 marks)

(c) Describe the characteristics of the savanna vegetation region (6 marks)

(d) You are planning to carry out a field study in a forest

(i) Give **four** reasons why it is important to seek permission from the school administration

(4marks)

(ii) List **three** sources of information you likely to use before the actual field study

(3 marks)

(iii) Identify **four** challenges you are likely to encounter during the field study

(4 marks)

10. (a) (i) Name **two** major deserts found in Africa (2 marks)

The diagram below represents features resulting from wind erosion in desert. Use it to answer question a (ii)

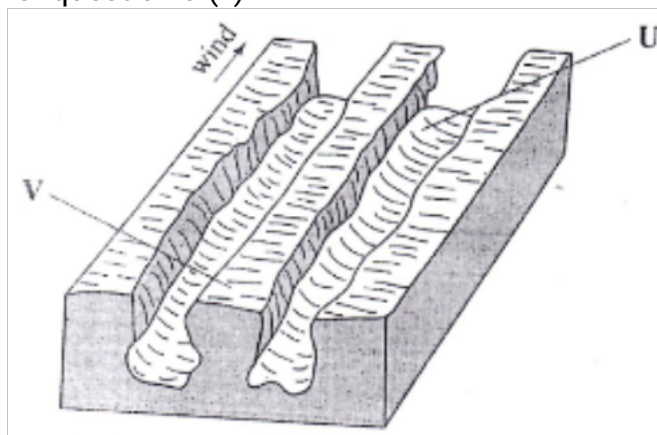

- (ii) Name the feature marked **U** and **V** (2 marks)
- (b) Describe the **three** processes through which wind transports its load (6 marks)
- (c) Using a well labeled diagram, describe how a barchans is formed (7 marks)
- (d) Explain **four** ways n which desert features are of significance to human activities

GEOGRAPHY
PAPER 1
2014
2 ³/₄ HOURS
Oct / Nov.

SECTION A

Answer ALL the questions in this section.

1. Name **two** types of hypabyssal rocks. (2 marks)

2 (a) The diagram below shows intrusive volcanic features.

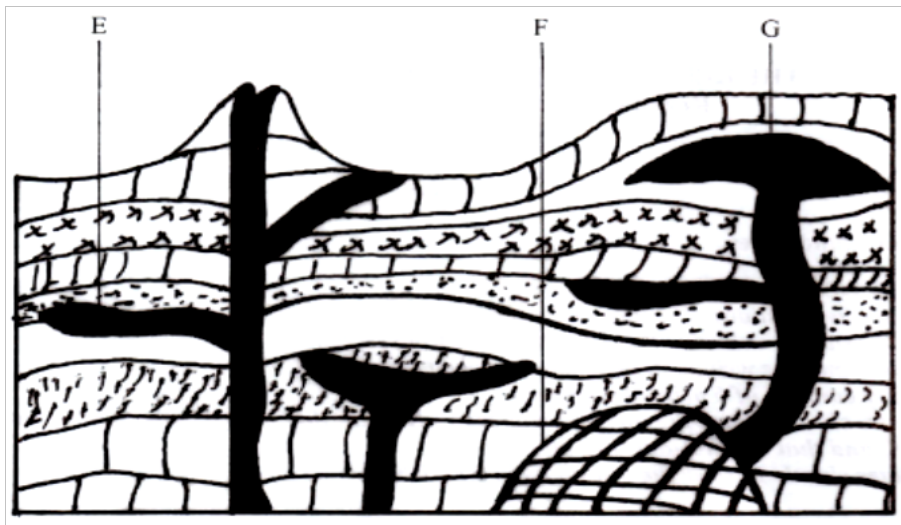

(a) Name the features marked E, F and G. (3marks)

b) Name **two** active volcanoes in Kenya. (2 marks)

3. (a) Give **three** processes in the hydrological cycle. (3marks)

b) State **four** factors that facilitate **deposition** in rivers (4marks)

4. a) Explain **two** reasons why wind is the dominant agent of erosion in arid areas (4marks)

b) Identify **two** features formed as a result of wind deposition in arid areas. (2marks)

5. (a) Describe podzolization as a process of leaching. (2marks)

b) State **three** ways in which mulching helps in soil cause. (3marks)

SECTION B

Answer **question 6** and any other **TWO** questions from this section.

6. Study the map of Migwani (1:50:000) Sheet 151/1 provided and answer the following questions.

a) (i) Give the longitudinal extent of the area covered by the map. (2marks)

(ii) What is the magnetic variation of the map? (1 mark)

(iii) Give the six figure grid reference for the junction of the roads D503 and D507. (2marks)

b) (i) Using a vertical scale of 1cm to represent 100 metres, draw a cross section along the line marked J-K.

(4marks)

ii) On it mark and label the following:

- Footpath; (1mark)
- Road; (1mark)
- Water pipeline; (1mark)
- Steep slope. (1mark)

iii) Calculate the vertical exaggeration of the cross section (2marks)

c) Citing evidence from the map, give **three** economic activities carried out in the area covered by the map. (6marks)

d) Explain how relief has influenced the distribution of settlement in the area covered by the map (4marks)

7. (a) (i) Describe the solar system. (2marks)

(ii) The local time at Manual, 60°E is 11.30.am. What is the time in Nairobi 37°E? (3marks)

(b) (i) State **five** characteristics of the mantle in the interior structure of the earth. (5marks)

(ii) Outline the evidence which support the theory of continental drift. (4marks)

(c) The diagram below represents the revolution of the earth.

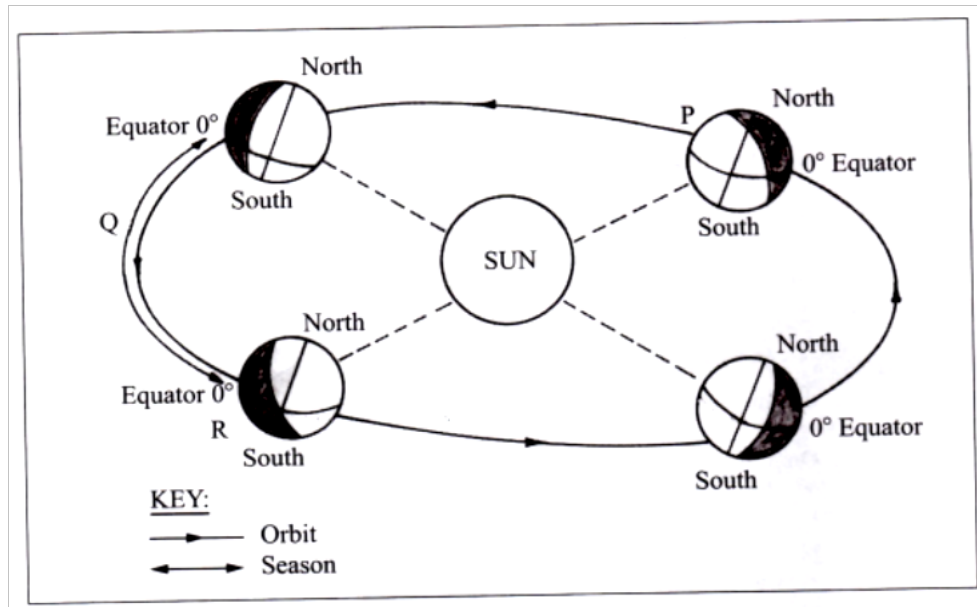

- (I) Name the solstice marked P. (1mark)
- (II) Identify the season represented in the region marked Q. (1mark)
- (iii) Describe the climatic conditions in Europe when the earth is in position R. (3mark)
- d) With the aid of a well labeled diagram, describe the occurrence of the solar eclipse. (6marks)
8. The map below shows some climatic regions of Kenya. Use it to answer question (a).

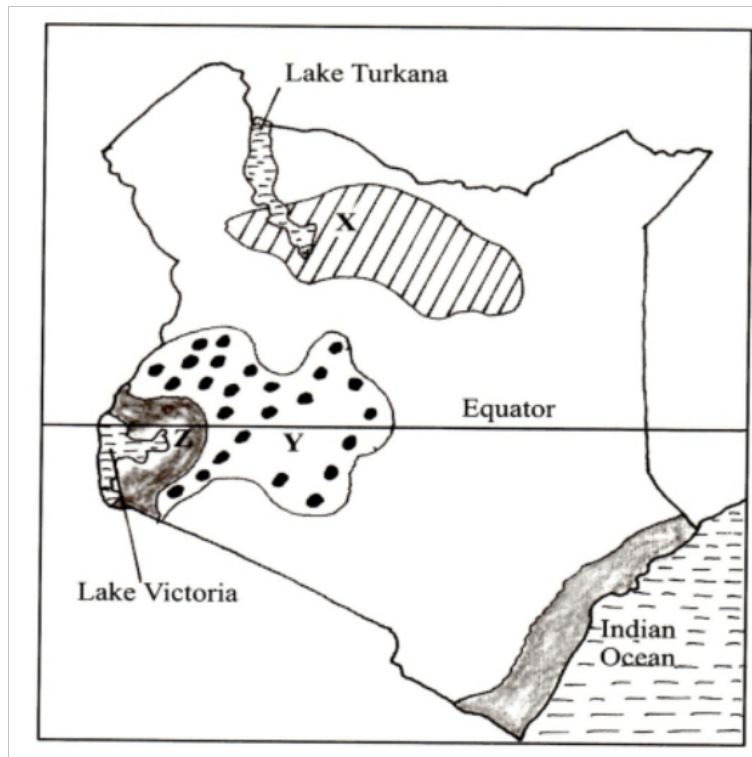

- (a) (i) Name the climatic regions marked X and Y (2marks)
- (ii) State three characteristics of the climatic region marked Z. (3marks)
- (b) Explain how each of the following factors influence climate:
 (i) Altitude; (4marks)
 (ii) Ocean currents; (4marks)
- (c) What are the negative effects of climate change on physical environment? (6marks)
- (d) Students visited a weather station to study recording of weather elements.
 (i) State **three** qualities in the construction of a Stevenson screen they would have observed during the study. (3marks)
 (ii) Identify **three** types of data they are likely to have collected during the study (3marks)
- 9 (a) (i) Name **two** types of submerged highland coasts. (2marks)
 (ii) Identify **two** resultant features of the emerged highland coast. (2marks)
- (b) State **three** factors influencing deposition by ocean waves. (3marks)

(c) With the aid of labeled diagrams describe the formation of the following coastal features

(i) Fringing reef; (5marks)

(ii) Spit. (5marks)

(d) Explain the significance of oceans to human activities. (8marks)

10. (a) (i) Name **two** mountains in East Africa which are ice capped. (2marks)

(ii) Identify three ways in which ice moves. (3marks)

b) Describe the formation of the following glacial features

(i) Hanging valley; (6marks)

(ii) Pyramidal peak. (6marks)

c) You are required to carry out a field study on erosional features in glaciated lowland area

(i) Give two reasons why you would require a working schedule. (2marks)

(ii) Name three erosional features you are likely to observe during the field study.

(3marks)

(iii) Give three follow up activities you would undertake after the field study.

(3marks)

GEOGRAPHY
PAPER 1
2015
2³/₄ HOURS
Oct / Nov.

SECTION A: (75 marks)
*Answer **all** the questions in this section.*

1. The earth represents the structure of the earth. Use it to answer question (a)

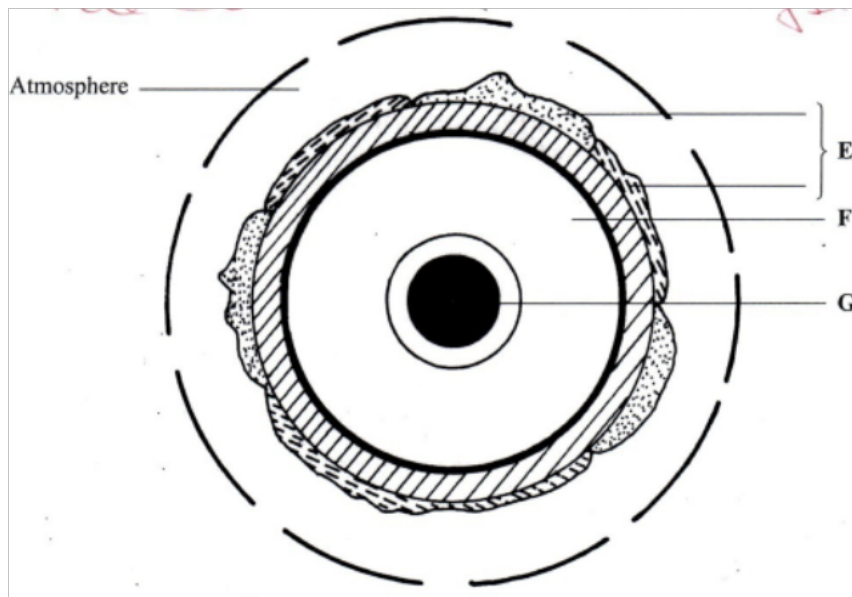

(a) Name :

- (i) The layers marked E and F. (2 marks)
- (ii) The minerals that make up the layer marked G. (2 marks)
- (b) Give two effects of the rotation of the earth on its axis (2 marks)

- 2.
- (a) What is a metamorphic rock? (2 marks)
- (b) Give three examples of metamorphic rocks (3 marks)
- 3.
- (a) Name two types of boundaries according to the plate tectonic theory (2 marks)
- (b) Give three effects of the movement of tectonics plates (3 marks)
- 4.
- (a) What is an earthquake ? (2 marks)
- (b) Identify the scale used to measure:
- (i) The intensity of earthquakes ; (1 mark)
- (ii) The magnitude of earthquakes (1 mark)
- 5.
- (a) Give three characteristics of a river in its middle stage (3 marks)

The diagram below shows a bird's foot delta. Use it to answer to answer question (b)

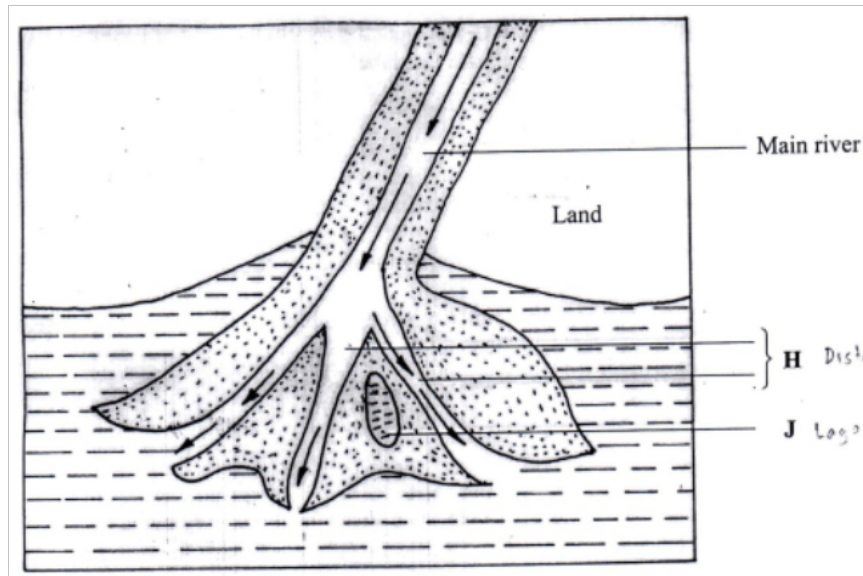

- (b) Identify the features marked H and J (2 marks)

SECTION B

Answer question 6 and any other two question from this section

6. Study the map of Busia 1:50,000 (sheet 101/1) provided and answer the following questions.
- (a)
- (i) Convert the ratio scale of the map extract into a statement. (2 marks)
 - (ii) What is the general direction of flow of river sio? (1 mark)
 - (iii) Identify the two dominant types of natural vegetation shown in the area covered by the map (2 marks)
- (b) Draw a square 10cm by 10cm to represent the area to the west of easting 30 and north of Northing 40. On the square, mark and label:
- (i) An international boundary;

- (ii) An air photo principal point;
- (iii) River sio;
- (iv) The area above 1200 metres above sea level

(c) Describe the relief of the area covered by the map

(d)

- (i) Explain how the following factors have influenced the distribution of settlements in the area covered by the map:
 - Drainage (2 marks)
 - Transport (2 marks)
- (ii) Citing evidence from the map, state three functions of Funyula town (6 marks)

7.

- (a) (i) define the term weather (2 marks)
- (ii) Explain how the following factors influence weather:
 - Cloud cover (4 marks)
 - Local winds (4 marks)

The diagram below represent a weather measuring instrument. Use it to answer question (b)

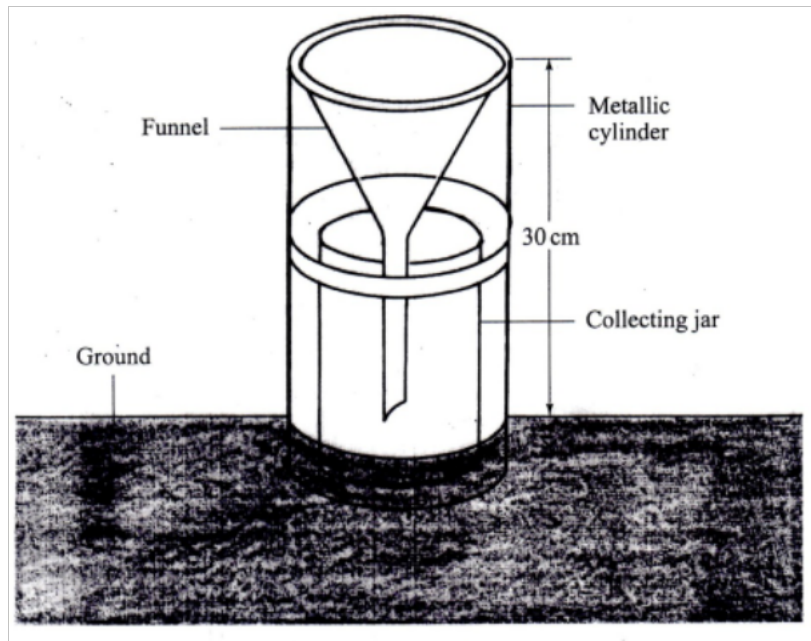

(b) (i) which element of weather is measured using the instrument shown above?
(1 mark)

(ii) describe how the above instrument is used. (3 marks)

The table below shows the temperature and rainfall readings for station T in one week. Use it to answer question (c)

Day	Mon	Tue	wed	thu	fri	Sat	su
Temperature °C	23	23	24	21	25	25	23
Rainfall in mm	50	49	55	45	60	60	49

(c) (i) calculate

Range of temperature for the week (1 mark)

The mean weekly rainfall (2 marks)

(iii) State four characteristics of the weather in station T. (4 marks)

(d) Give four characteristics of the stratosphere (4 marks)

8.

(a) (i) apart from the rift valley, name three other relief features formed as a result of faulting. (3 marks)

(iii) With the aid of diagrams, describe how the great rift valley may have been formed by tensional forces (3 marks)

(b) Explain three ways in which faulting may influence drainage systems. (6 marks)

(c) Describe four ways in which features resulting from faulting are significance to the economy of Kenya. (8 marks)

9.

(a)

(i) Apart from alternate wetting and drying, name three other processes of mechanical weathering. (3 marks)

(ii) Describe the following processes of weathering :

- Alternate wetting and drying; (3 marks)

- Hydrolysis; (2 marks)

- Carbonation (3 marks)

(b)

(i) State three conditions that influence the process of solifluction in

mass wasting (3 marks)

- (ii) Give three negative effects of mass wasting on the physical environment (3 marks)

(c) You are planning to carry out a field study on types of mass wasting .

- (i) Identify three methods you would use to collect data. (3 marks)
- (ii) Give three types of rapid mass wasting that you are likely to observe during the field study. (3 marks)
- (iii) State two ways in which the information collection collected during the field study would be useful to the local community (2 marks)

10. The diagram below represents an artesian basin. Use it to answer question (a)

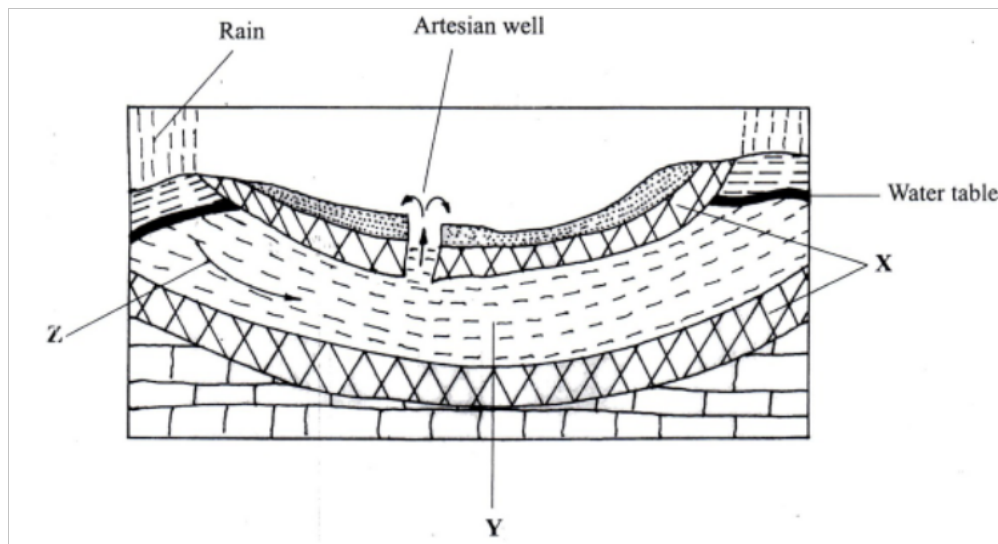

(a) Identify :

- (i) The layers marked X and Y (2 marks)
- (ii) The process marked Z (1 mark)

(b) Explain how the following factors influence the amount of underground

water in limestone areas :

(i) Rainfall (4 marks)

(ii) Vegetation cover (4 marks)

(c)

(i) Apart from stalagmites, name three other underground features formed in limestone areas (3 marks)

(ii) With the aid of a diagram, describe how a stalagmite is formed (8 marks)

(d) Give three reasons why there are few settlements in karst landscapes (3 marks)

**GEOGRAPHY
PAPER 1
2016
2 3/4 HOURS**

For marking schemes, call/Whatsapp-0746711892.

Oct / Nov.

SECTION A

Answer all the questions in this, section.

1. (a) How does a sea breeze occur? (2mks)
- (b) Use the map of Africa below to answer question (b) (i)

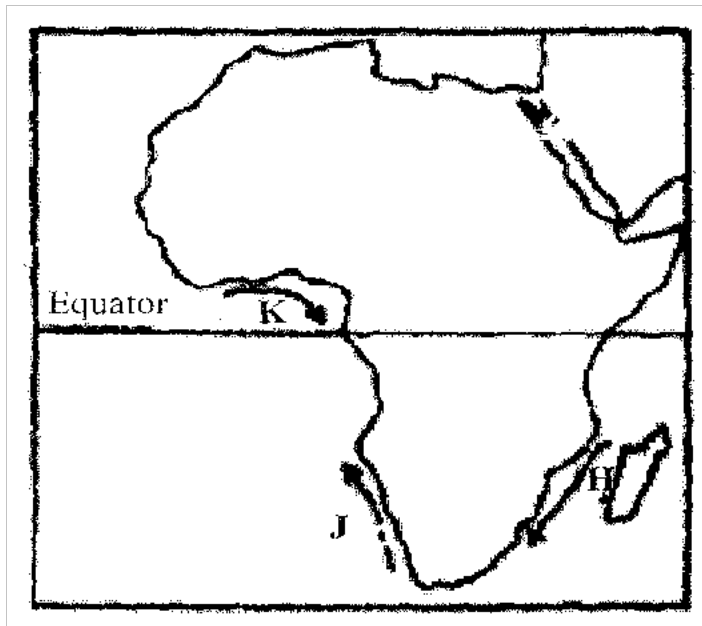

- (i) Name the ocean currents marked H, J and K. (3 mks)
- (ii) State **two** effects of a warm ocean current on the adjacent coastlands, (2 mks)
2. (a) Name **two** types of boundaries according to the plate tectonic theory. (2mks)
- (b) Give **three** effects of the movement of tectonic plates. (2mks)
3. The diagram below represents the structure of the atmosphere. Use it to answer question (a) The structure of the Atmosphere

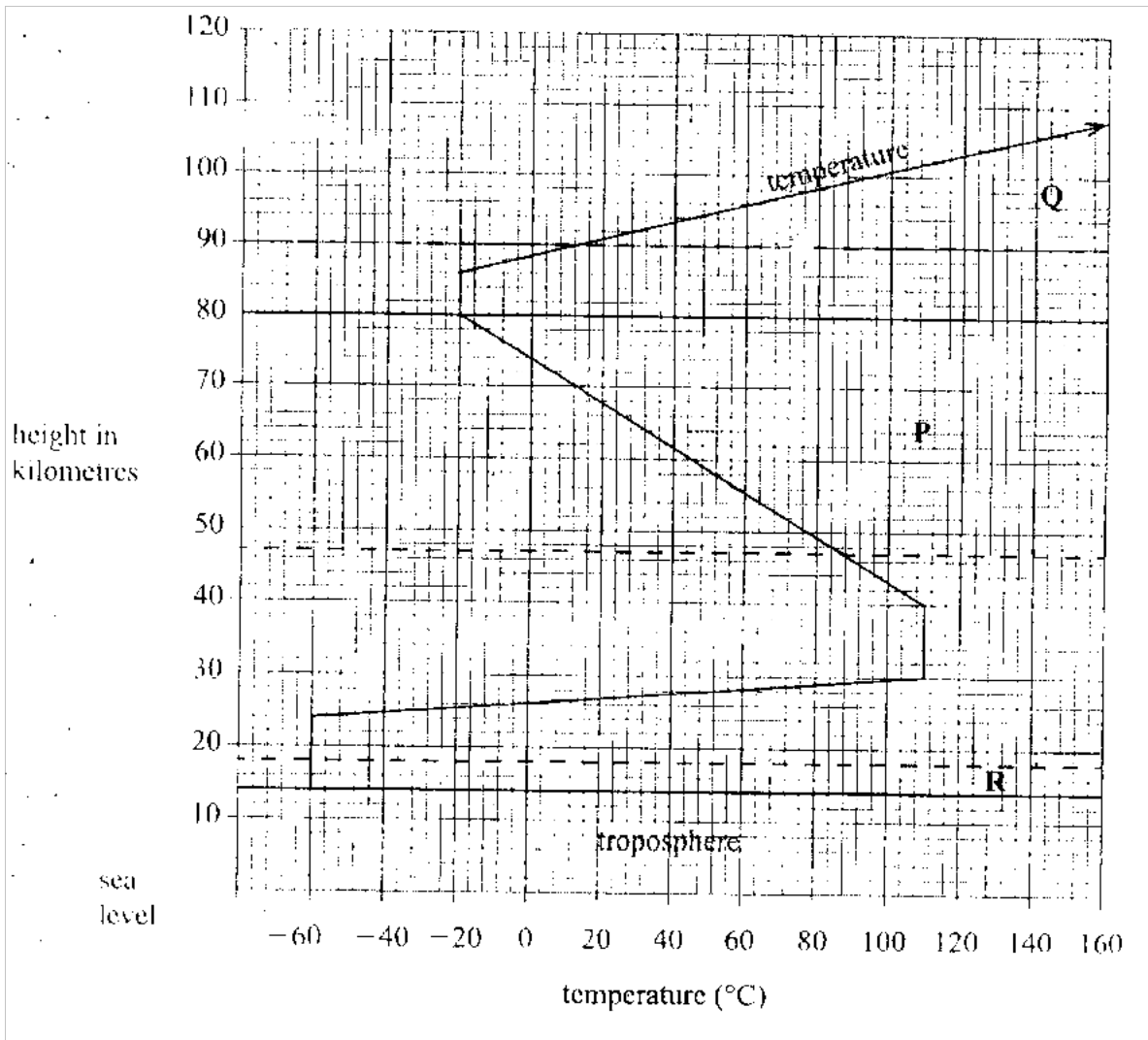

a) Name

i) The parts marked P and Q
(2 mks)

ii) The layer of discontinuity marked R.

(1 mk)

b) State two characteristics of weather conditions in the troposphere.
(2mks)

4. The diagram below shows coastal features

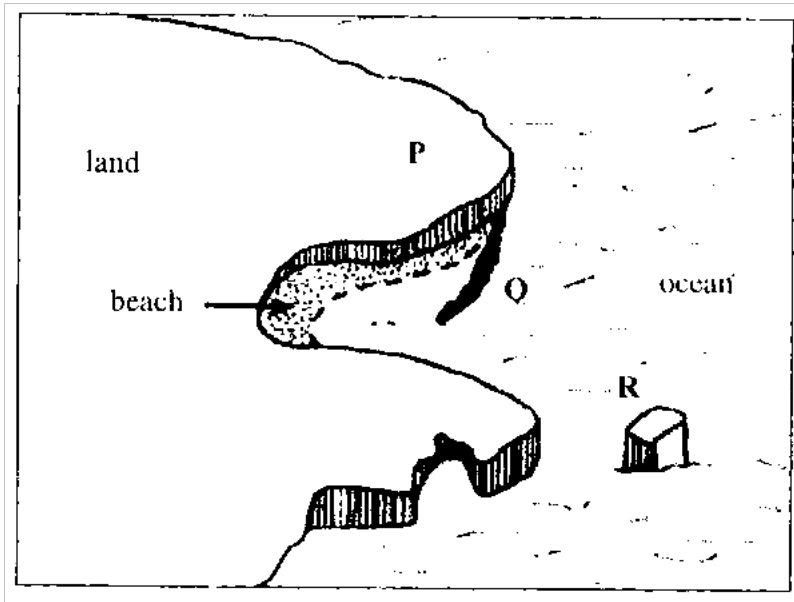

- a) Name the features marked P, Q and R. (3 mks)
- b) State two conditions necessary for the formation of a beach (2 mks)

5. Name the three major deserts in Africa (3 mks)

SECTION B

Answer question 6 and any other two questions from this section.

6. Study the map of Kitale 1:50,000 (sheet 75/3) provided and answer the following questions.

- (i) Identify two human made features found at the grid square 2320. (2 mks)
- (ii) What is the altitude of the highest point in the area covered by the map? (2 mks)
- (iii) Give three types of natural vegetation found in the area covered by the map. (3 mks)
- (b) (i) What is the bearing of the air photo principal point at grid square 3426 from the air photo principal point at grid square 2931? (2 mks)

- (ii) Measure the distance of the dry weather road (C640) from the junction at point M (345142) from the junction at point N (416201) Give your answer in kilometers. (2 mks)
- (c) (i) Using a scale of 1 cm to represent 40 metres, draw a cross-section from grid reference 410180 to grid reference 500180. (4 mks)
- (ii) On the cross-section mark and name the following:
- a dry weather road; (1mk)
 - River Kaptarit (1mk)
 - a ridge, (1mk)
- (iii) Calculate the (VE) vertical exaggeration of the section.
- (d) Citing evidence from the map, identify five social services offered in Kitale.
- (i) Name **two** types of submerged highland coasts. (2 mks)
- (ii) Identify **two** resultant features of the emerged highland 'coasts. (2 mks)
7. a) i) name two types of submerged highland coasts (2mks)
 ii) identify two resultant features of the emerged highland coasts (2mks)
- b) State **three** factors influencing deposition by ocean waves, (3 mks)
- c) With the aid of labelled diagrams, describe the formation of the following coastal features:
- (i) Fringing reef; (2 mks)
- (ii) Spit. (2 mks)
- d) Explain the significance of oceans to human activities. (8mks)
8. a) (i) What is a lake? (2 mks)
 (ii) Name two crater lakes in Kenya. (2 mks)

- b) Describe how each of the following lakes are formed:
- (i) corrie lake; (4 mks)
 - (ii) oasis; (4 mks)
 - (iii) lagoon. (4 mks)

c) (i) Give **three** reasons why some lakes in Kenya have saline water. (3 mks)

- (ii) Explain how each of the following has affected lakes in Kenya:
- deforestation (2 mks)
 - industrialization (2 mks)
 - water needs. (2 mks)

9. (a) (i) Name three types of faults.
 (ii) Apart from compressional forces, explain two other processes that may Cause faulting.. (4 mks)

(b) With the aid of diagrams, describe how compressional forces may have led to the formation of the Great Rift Valley, (8 mks)

(c) Explain five ways in which faulting is of significance to human activities. (10 mks)

10.
 a) Differentiate between magma and lava. (2mks)
 b) The diagram below shows some intrusive volcanic features.

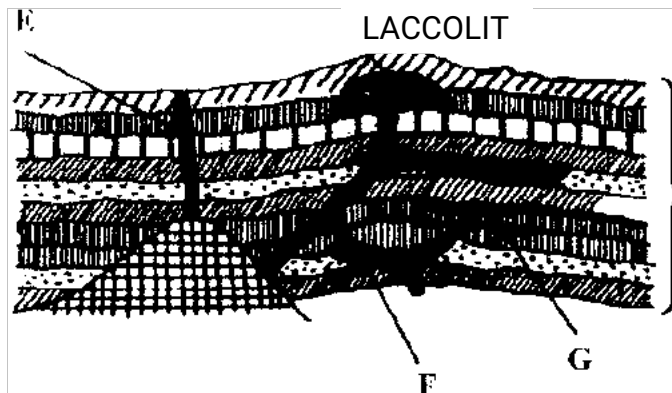

Rocks of the

c) Name the features marked E, F, and G (4 mks)

(c) Describe how the following features are formed and for each give an example

From Kenya:

(i) a crater (3 mks)

(ii) a geyser (5 mks)

(iii) a Lava plateau. (4 mks)

(d) Explain **four** ways in which volcanic features influence human activities. (8 mks)



'an investment of knowledge pays

The following KASNEB notes are available;

 **ATD**

 **CPA**

 **CS**

 **CIFA**

Call Mdm.Mariam:0746711892 to acquire them

