

F3 TOPICAL REVISION CHEMISTRY

***A SERIES OF TOPICAL QUESTIONS IN FORM
THREE CHEMISTRY***

***FOR MARKING SCHEMES
CALL/WHATSAPP 0705525657***

MR ISABOKE 0705525657

GAS LAWS

1. A sample of unknown compound gas **X** is shown by analysis to contain Sulphur and Oxygen. The gas requires 28.3 seconds to diffuse through a small aperture into a vacuum. An identical number of oxygen molecules pass through the same aperture in 20seconds. Determine the molecular mass of gas X (O= 16, S= 32)
2. (a) State Graham's Law of diffusion
(b) Gas **V** takes 10 seconds to diffuse through a distance of one fifth of a meter. Another gas **W** takes the same time to diffuse through a distance of 10 cm. if the relative molecular mass of gas **V** is 16.0; calculate the molecular mass of **W**
3. (a) State Charles' Law
(b) The volume of a sample of nitrogen gas at a temperature of 291K and 1.0×10^5 Pascals was $3.5 \times 10^{-2} \text{m}^3$. Calculate the temperature at which the volume of the gas would be $2.8 \times 10^{-2} \text{m}^3$ at 1.0×10^5 pascals.
4. 60 cm^3 of oxygen gas diffused through a porous partition in 50 seconds. How long would it take 60 cm^3 of sulphur (IV) oxide gas to diffuse through the same partition under the same conditions?
(S = 32.0, O = 16.0)
5. (a) State Graham's law of diffusion
(b) 30 cm^3 of hydrogen chloride gas diffuses through a porous pot in 20seconds. How long would it take 42 cm^3 of sulphur(IV) oxide gas to diffuse through the same pot under the same conditions (H = 1 Cl = 35.5 S = 32 O = 16)
6. a) State **Boyles law**
b) Sketch a graph that represents Charles' law
c) A gas occupied a volume of 250 cm^3 at -23°C and 1 atmosphere. Determine its volume at 127°C when pressure is kept constant.
7. A factory produces Calcium Oxide from Calcium Carbonate as shown in the equation below
$$\text{CaCO}_3 (\text{s}) \longrightarrow \text{CaO} (\text{s}) + \text{CO}_2 (\text{g})$$

(a) What volume of Carbon (IV) Oxide would be produced from 1000kg of Calcium Carbonate at s.t.p (Ca = 40, C = 12, O = 16, Molar gas volume at s.t.p = 22.4 dm^3)
8. A fixed mass of gas occupies 200 cm^3 at a temperature of 23°C and pressure of 740mmHg. Calculate the volume of the gas at -25°C and 780mmHg pressure
9. Gas **K** diffuses through a porous material at a rate of $12 \text{ cm}^3 \text{ s}^{-1}$ where as **S** diffuses Through the same material at a rate of $7.5 \text{ cm}^3 \text{ s}^{-1}$. Given that the molar mass of **K** is 16, calculate the molar mass of **S**
10. (a) State Gay Lussac's law

11. (a) What is the relationship between the rate of diffusion of a gas and its molecular mass?
 (b) A sample of Carbon (IV) Oxide takes 200 seconds to diffuse across a porous plug.
 How long will it take the same amount of Carbon (II) Oxide to diffuse through the same plug? (C=12, O=16)

12. Below are structures of particles. Use it to answer questions that follow. In each case only electrons in the outermost energy level are shown

key

P = Proton

N = Neutron

X = Electron

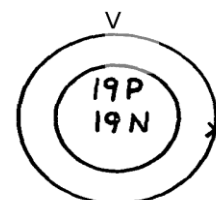
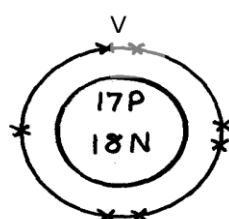
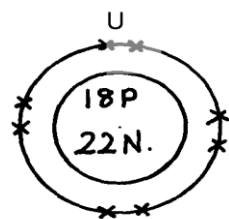

- (a) Identify the particle which is an anion
 (b) Choose a pair of isotopes. Give a reason
13. The figure below shows two gases **P** and **Q** diffusing from two opposite ends 18 seconds after the experiment

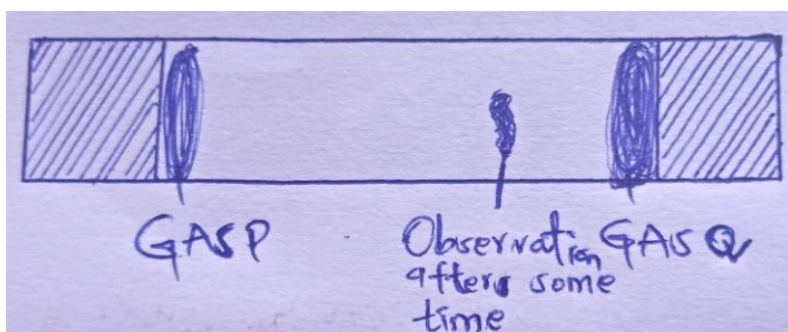

- (a) Which of the gases has a lighter density?
 (b) Given that the molecular mass of gas **Q** is 17, calculate the molecular mass of **P**
14. Identify the particles that facilitate the electric conductivity of the following substances
 (i) Sodium metal
 (ii) Sodium Chloride solution
 (iii) Molten Lead Bromide
15. Gas **B** takes 110 seconds to diffuse through a porous pot, how long will it take for the same amount of ammonia to diffuse under the same conditions of temperature and pressure? (RMM of **B** = 34 RMM of ammonia = 17)
16. A gas occupies 5dm³ at a temperature of -27°C and 1 atmosphere pressure. Calculate the volume occupied by the gas at a pressure of 2 atmospheres and a temperature of 127°C
17. A fixed mass of gas occupies 200 cm³ at a temperature of 23°C and a pressure of 740 mm Hg. Calculate the volume of the gas at -25°C and 790 mm Hg pressure.
18. (a) State the Graham's law
 (b) 100cm³ of Carbon (IV) oxide gas diffused through a porous partition in 30seconds.
 How long would it take 150cm³ of Nitrogen (IV) oxide to diffuse through the same partition under the same conditions? (C = 12.0, N = 14.0, O = 16.0)

THE MOLE

1. In an experiment magnesium ribbon was heated in air. The product formed was found to be heavier than the original ribbon. Potassium manganate (VII) was on the other hand, heated in air and product formed was found to be lighter. Explain the differences on the observation made
2. In a filtration experiment 25cm^3 of a solution of Sodium Hydroxide containing 8g per litre was required for complete neutralization of 0.245g of a dibasic acid. Calculate the relative molecular mass of the acid (Na = 23.0, O = 16, H= 1)
3. **D** grams of Potassium hydroxide were dissolved in distilled water to make 100cm^3 of solution. 50cm^3 of the solution required 50cm^3 of 2.0M nitric acid for complete neutralization. Calculate the mass **D** of Potassium hydroxide (RFM of KOH = 56)

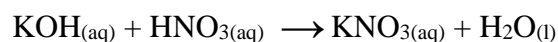

4. When excess dilute hydrochloric acid was added to sodium sulphite, 960cm^3 of sulphuric (IV) Oxide gas was produced. Calculate the mass of sodium sulphate that was used. (Molar gas volume = 24000cm^3 and Molar mass of sulphite = 126g)
5. The equation of the formation of iron (III) chloride is

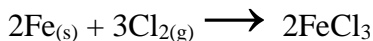

- Calculate the volume of chlorine which will react with iron to form 0.5g of Iron (III) chloride. (Fe = 56 Cl=35.5). Molar gas volume at 298K = 24dm^3)
6. 15.0cm^3 of ethanoic acid (CH_3COOH) was dissolved in water to make 500cm^3 of solution. Calculate the concentration of the solution in moles per litre [C=12, H = 1, O = 16, density of ethanoic acid is $1.05\text{g}/\text{cm}^3$]
 7. When 1.675g of hydrated sodium carbonate was reacted with excess hydrochloric acid, the volume carbon (IV) oxide gas obtained at room temperature and pressure was 150cm^3 . Calculate the number of moles of water of crystallization in one mole of hydrated sodium carbonate:- (Na=23, H =1, C=12, O=16, MGV at R.T.P = 24000cm^3)
 8. How many chloride ions are present in 1.7g of magnesium chloride crystals? (Avogadro's constant = 6.0×10^{23} , Mg = 24, Cl = 35.5)
 9. 0.84g of aluminium reacted completely with chlorine gas. Calculate the volume of Chlorine gas used (Molar gas volume is 24dm^3 , Al = 27)
 10. 6.4g of a mixture of sodium carbonate and sodium chloride was dissolved in water to Make 50cm^3 solution. 25cm^3 of the solution was neutralized by 40cm^3 of 0.1M $\text{HCl}_{(\text{aq})}$. What is the percentage of sodium chloride in the solid mixture?
 11. An unknown mass, **x**, of anhydrous potassium carbonate was dissolved in water and the solution made up to 200cm^3 . 25cm^3 of this solution required 18cm^3 of 0.22M nitric (V) acid for complete neutralization. Determine the value of **x**. (K=39.0, C =12.0, O =16.0)

12. Calculate the volume of oxygen gas used during the burning of magnesium
(O = 16 molar gas volume = 24,000cm³ at room temperature)
13. A hydrated salt has the following composition by mass. Iron 20.2 %, oxygen 23.0%, sulphur 11.5%, water 45.3%
- Determine the formula of the hydrated salt (Fe=56, S=32, O=16, H=11)
 - 6.95g of the hydrated salt in **c(i)** above were dissolved in distilled water and the total volume made to 250cm³ of solution. Calculate the concentration of the resulting salt solution in moles per litre. (Given that the molecular mass of the salt is 278)
14. (i) Lead (II) ions react with iodide ions according to the equation;

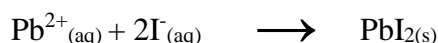

300cm³ of a 0.1m solution of iodide ions was added to a solution containing excess lead II ions. Calculate the mass in grams of lead II iodide formed

(ii) Identify the colour of the product formed in **(i)**

15. a) The diagram below represents part of the structure of sodium chloride crystal

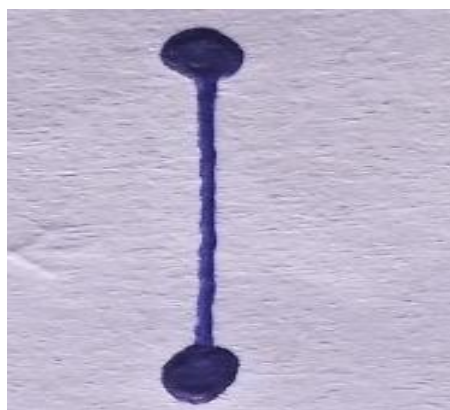

The position of one of the sodium ions in the crystal is shown as;

- On the diagram, mark the positions of the other three sodium ions
 - The melting and boiling points of sodium chloride are 801C and 1413C respectively. Explain why sodium chloride does not conduct electricity at 25C, but does not at temperatures between 801C and 1413C
- b) Give a reason why ammonia gas is highly soluble in water
- c) The structure of ammonium ion is shown below;

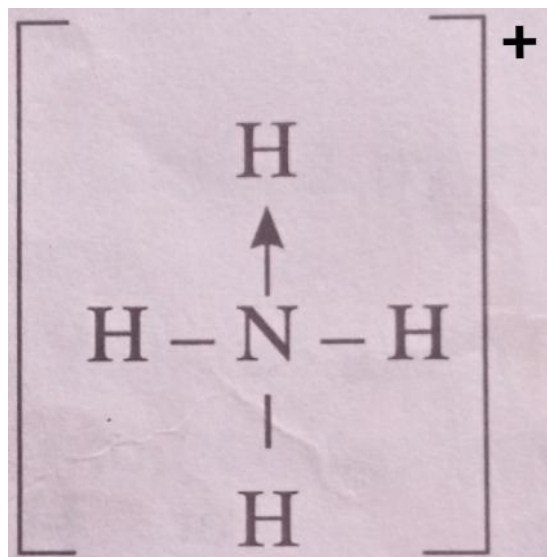

Name the type of bond represented in the diagram by N -H

d) Carbon exists in different crystalline forms. Some of these forms were recently discovered in soot and are called fullerenes

i) What name is given to different crystalline forms of the same element

ii) Fullerenes dissolve in methylbenzene while the other forms of carbon do not. Given that soot is a mixture of fullerenes and other solid forms of carbon, describe how crystals of fullerenes can be obtained from soot

iii) The relative molecular mass of one of the fullerenes is 720. What is the molecular mass of this fullerene

16. Calculate the volume of oxygen gas used during the burning of magnesium (O = 16, molar

gas volume = 24,000cm³ at room temperature)

17. Study the information in the table below and answer the questions that follow

Number of carbon atoms per molecule	Relative molecular mass of the hydrocarbon
2	28
3	42
4	56

i) Write the general formula of the hydrocarbons in the table

ii) Predict the relative atomic mass of the hydrocarbons with 5 carbon atoms

iii) Determine the relative atomic mass of the hydrocarbon in (ii) above and draw its structural formula (H=1.0, C=12.0)

18. A hydrated salt has the following composition by mass. Iron 20.2 %, oxygen 23.0%, sulphur 11.5%, water 45.3%
- Determine the formula of the hydrated salt (Fe=56, S=32, O=16, H=11)
(3 mks)
 - 6.95g of the hydrated salt in c(i) above were dissolved in distilled water and the total volume made to 250cm³ of solution. Calculate the concentration of the resulting salt solution in moles per litre. (Given that the molecular mass of the salt is 278)
19. a) Galvanized iron sheets are made by dipping the sheets in molten Zinc.
- Explain how zinc protects iron from rusting
 - Name the process applied in galvanization of iron with zinc
20. Calculate the percentage of copper in 1.0g of the alloy
(Cu = 63.5 Mg = 24)
21. A factory uses nitric acid and ammonia gas as the only reactant for the preparation of the fertilizer if the daily production of the fertilizer is 4800kg. Calculate the mass of ammonia gas used daily
(N = 14.0, O= 16.0, H = 1.0)
22. Calculate the volume of sulphur (VI) oxide gas that would be required to produce 178kg of oleum in step 3 molar gas volume at s.t.p = 22.4 litres H = 1 O = 16 S = 32
23. Using the answer in d (ii) above, determine:
- The volume of 1M nitric acid that would react completely with one mole of copper
(Cu = 63.5)
 - The volume of Nitrogen (IV) oxide gas produced when one mole of copper reacts with excess 1M nitric acid at room temperature
24. A sample of biogas contains 35.2% by mass of methane. A biogas cylinder contains 5.0kg of the gas. Calculate:
- Number of moles of methane in the cylinder (Molar mass of methane = 16)
 - Total volume of carbon (IV) oxide produced by the combustion of methane in the cylinder (Molar gas volume = 24.0dm³ at room temperature and pressure)
25. 0.84g of aluminium were reacted completely with chlorine gas. Calculate the volume of chlorine gas used. (Molar gas volume is 24dm³, Al = 27)
26. 3.52g of Carbon (IV) Oxide and 1.40g of water are produced when a mass of a hydrocarbon is completely burnt in oxygen. Determine the empirical formula of the hydrocarbon;
(H = 1 , C= 12, O = 16)
27. Calculate the number of water molecules when 34.8g Na₂CO₃ xH₂O is heated and 15.9g Of anhydrous Na₂CO₃ obtained (H=1, O=16, Na= 23, C = 12)
28. A weighed sample of crystalline sodium carbonate (Na₂CO₃nH₂O) was heated in a crucible until there was no further change in mass. The mass of the sample reduced by 14.5%. Calculate the number of moles (n) of water of crystallization (Na = 23, O = 16, C = 12, H = 1)

29. In a reaction 20cm³ of 0.1 M Sodium Carbonate completely reacted with 13cm³ of dilute sulphuric acid. Find the molarity of the sulphuric acid used.
30. An organic compound P contains 68.9% carbon, 13.5% hydrogen and 21.6% oxygen. The relative formula mass of **p** is 74. Determine its molecular formula. [C=12, H=1, O=16]
31. Campers GAZ cylinder contains about 1.12dm³ of butane measured at 0° and 1atm. Given that 25% of heat is lost, what is the maximum volume of water at room temperature which can be boiled to 100°C in order to make some coffee?

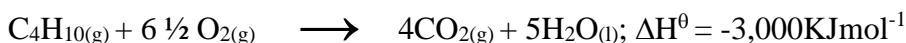

(Specific heat capacity of water = 4.2J g⁻¹C^{-0c}, density of water 1gcm⁻³ Molar gas volume 22.41 at s.t.p)

32. An aqueous solution containing anhydrous sodium carbonate was prepared by dissolving 19.6g of the salt in 250cm³ of distilled. Calculate the volume of **2M** of magnesium chloride solution required to precipitate all the carbonate ions in the solution. (Na=23, C= 12; O = 16; Mg = 24; Cl =35.5)
33. 10.08g of ethanedioic acid (H₂C₂O₄.xH₂O) crystals were dissolved in water and made to 1dm³ solution. 25.0cm³ of this solution was completely neutralized by 20cm³ of 0.2M sodium hydroxide solution.
- Calculate**
- Molarity of the acid
 - the value of **x** in H₂C₂O₄.xH₂O acid
34. 1.6g of magnesium metal is reacted with excess hydrochloric acid. Calculate the volume of hydrogen gas produced (Molar gas volume at stp = 22.4dm³ Mg=24)
35. 60 litres of sulphur(IV) oxide were made to react with 40 litres of oxygen.
- Which reactant was in excess and by how much?
 - What is the volume of the product?
36. During welding of cracked railway lines by thermite 12.0g of oxide of iron is reduced by aluminium to 8.40g of iron. Determine the empirical formula of the oxide (Fe= 56.0, O= 16.0)

ORGANIC CHEMISTRY 1

- State one source of alkanes
 - ethane gas was reacted with one mole of bromine gas. State one observation made during this extraction
- But-2-ene undergoes hydrogenation according to the equation given below

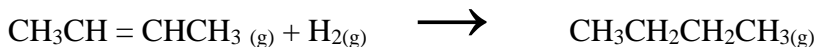

- Name the product formed when but-2-ene reacts with hydrogen gas
 - State **one** industrial use of hydrogenation
- Write the structures of the following compounds:-
 - But-2-yne
 - 1,2-dichloroethane
 - What is meant by Isomerism?
 - Draw and name **two** Isomers of butene.
 - Study the information in the table below and answer the questions that follow:

Ion	No. of protons	No. of electrons
P ³⁻	7	10
Q ⁺	19	18
R ²⁺	12	10

- Write the electron arrangement of element P.
 - Give the group and period to which elements Q and R respectively.
Q
 - R
- Compound W reacted with chlorine to form compound X only. The structural formula of X is shown below:
$$\begin{array}{cccc} \text{CH}_3 & - & \text{CH} & - & \text{CH} & - & \text{CH}_3 \\ & & \parallel & & \parallel & & \\ & & \text{Cl} & & \text{Cl} & & \end{array}$$
 - Give the structural formula and name of compound W
 - Name compound X
.....
 - In petrol chemical industries, long chain alkanes are broken down into simpler substances in a process called cracking
 - Why is cracking necessary?
 - State the **two** conditions required in cracking
 - Draw the structure of 1-chloro-2, 2-dimethylpropane
 - Name the product formed when but-2-ene reacts with hydrogen gas

[b]State one industrial use of hydrogenation

9. (a) Give the IUPAC systematic names of compounds **Q** and **R**



(b) The organic compounds **Q** and **R** in (b) above, are formed when one mole of hydrocarbon **N** reacts with two moles of hydrogen chloride gas;

(i) Structural formula of **N**

(ii) The IUPAC systematic name of **N**

10. Distinguish between the isotopes and isomers

11. Polymerisation of ethene takes place as shown in the equation below



Name the type of polymerisation undergone by ethene in the reaction above

12. (a) State Gay Lussac's law

13. 10cm^3 of methane (CH_4) gas is exploded with 150cm^3 of air containing 20% oxygen and 80% nitrogen. The products were allowed to cool to room temperature. What will be the total volume of the gases at the end of the reaction?

14. Give the open structures of:-

(i) 3-chlorohex-1-yne

(ii) CH_3OH

15. A fixed mass of gas occupies 105cm^3 at -14°C and 650mmHg pressure. At what temperature in degrees Celsius will it have a volume of 15cm^3 if the pressure is adjusted to 690mmHg pressure?

16. Write an equation for the reaction that takes place between ethene and concentrated Sulphuric (VI) acid

17. Petroleum (crude oil) is a mixture of several compounds which are separated in a Changamwe refinery by means of apparatus as shown below:

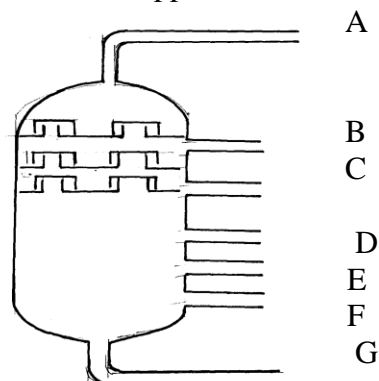

- (a) (i) What is the name of the apparatus above
- (ii) What is the name of the process which is used in separation of crude oil
- (iii) What physical property of compounds in the mixture does the separation depend
- (iv) Use the letter **A** to **G** to describe where the following could be formed:.
- I. The fraction that represents gases
 - II. The fraction that represents the largest molecules
 - III. The fraction that represents liquids with the lowest boiling points
- (b) State the use of product produce at
- G**.....
- C**.....
- (c) Draw apparatus for the separation of the product produce at **D** and water

18. [a]In which homologous series do the following compounds belong?

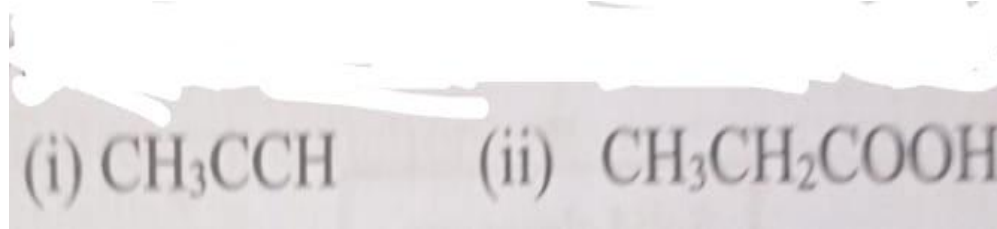

- [b]Raw rubber is heated with Sulphur in the manufacture of natural rubber
- [i]What is the name given to the process?
 - [ii]Why is the process necessary?
- [c]Study the scheme given below and answer the questions that follow

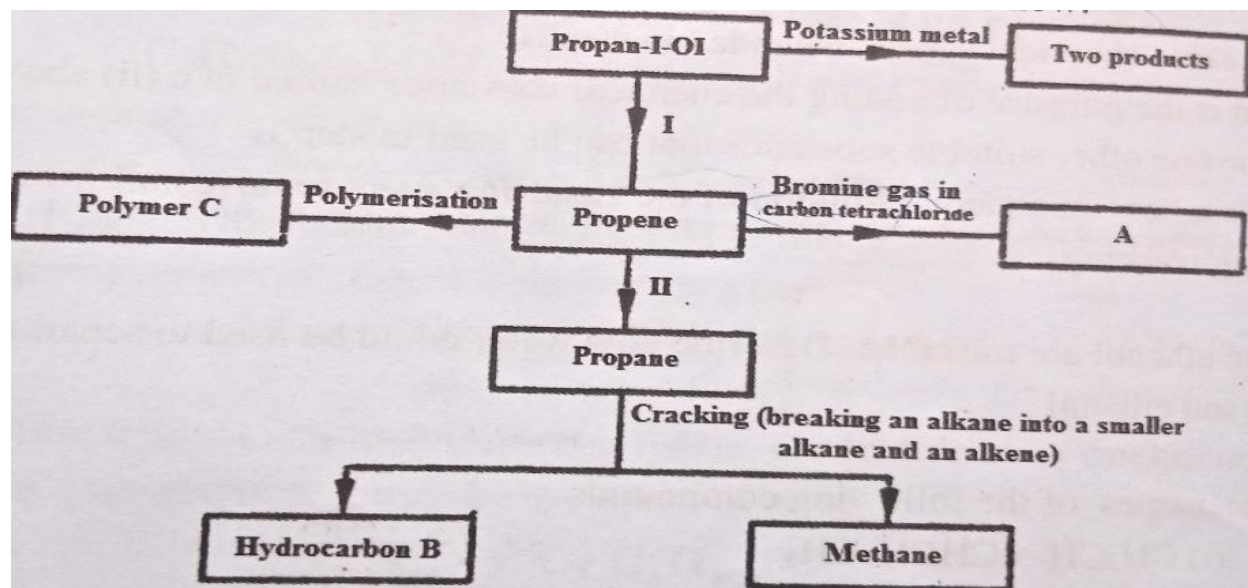

[i] Write an equation for the reaction between propan-1-ol and potassium metal

[ii] Name process one and two

[iii] Identify the products A and B

[iv] Name one catalyst used in process II

[v] Draw the structural formula of the repeating unit in the polymer C

[d] State two industrial uses of methane

19. The diagram below represents a large-scale fractional distillation plant used to separate the components A, B, C and D in a mixture

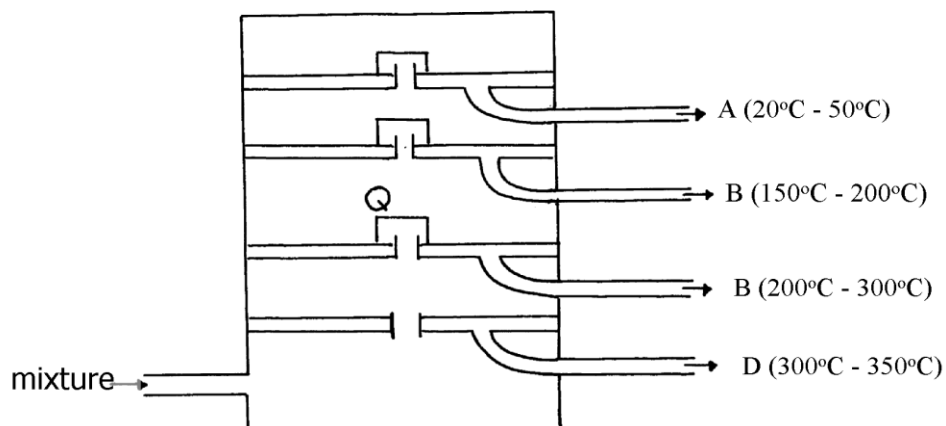

- (a) The components have the following average relative molecular masses not necessarily in that order; 282, 184, 44 and 128.
- What is the physical state of **B** at the position marked **Q**?
 - Which component has an average relative molecular mass of 128? Explain
 - State with a reason whether **C** is pure or impure
 - Explain how the mixture is separated into its components
 - Name **two** naturally occurring mixtures that are separated using this process

20. The figure below represents the setup that was used to crack an alkane

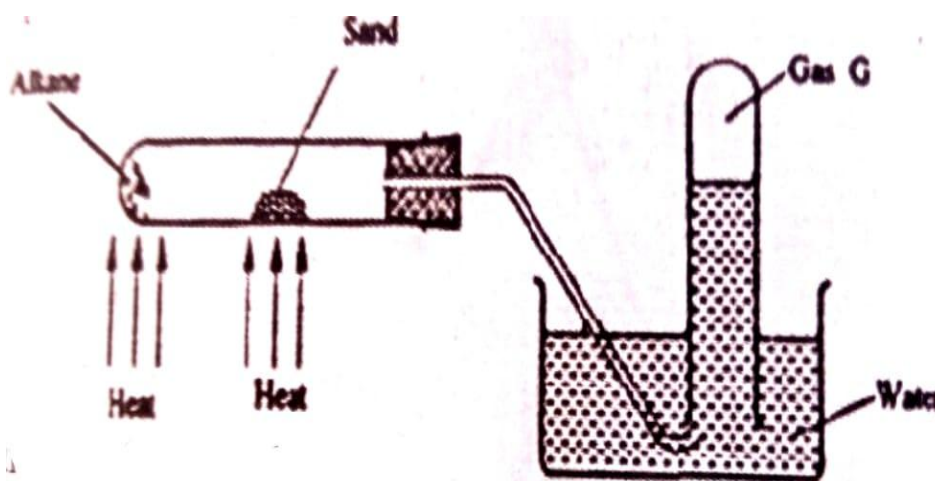

- What was the purpose of the sand?
- After some time a colourless gas **G** is collected in the test tube. Describe a chemical test and the observations that would be made in order to identify the class of compounds to which gas **G** belongs

21. a) The table below gives information about the major constituents of crude oil. Study it and answer the questions that follow:

Constituent	Boiling point °C
Gases	Below 40
Petrol	40-175
Kerosene	175-250
Diesel	250-350
Lubricating oil	350-400
Bitumen	Above 400

- Which of the constituents of crude has molecules with the highest number of carbon atoms? Explain
- Name the process you would use to separate a mixture of petrol and diesel and explain how the separation takes place

- iii) Explain why the constituents of crude oil do not have a sharp boiling point
- iv) Name the gas that is likely to be a constituent of crude oil and write its formula

b) i) What condition could cause a poisonous gas to be formed when kerosene is burnt.

Explain

ii) Give **one** use of bitumen

22. (a) The set-up below was used to prepare ethyne gas

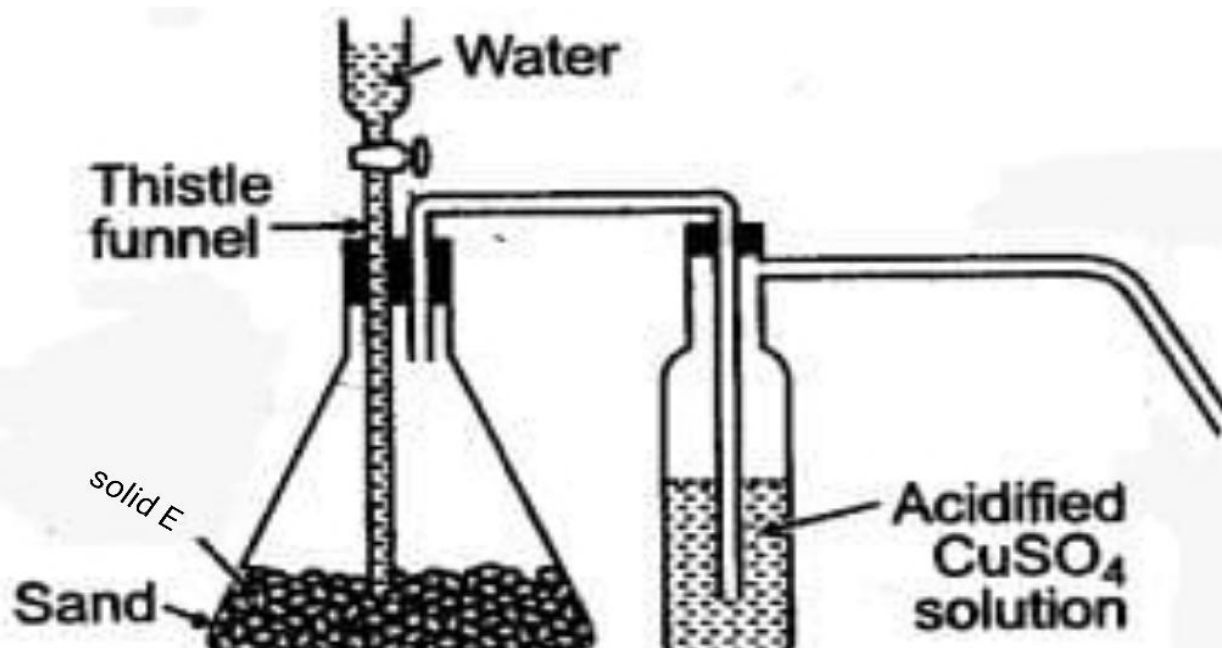

- (i) Identify solid E
- (ii) Complete the diagram to show how the gas can be collected
- (iii) Write an equation to show how the gas is formed
- (iv) Complete the equation below:

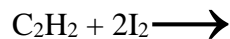

- (v) What is the role of sand in the experiment?
- (b) (i) Explain the meaning of esterification
- (ii) Complete the equation below :

$$\text{CH}_3\text{COOCH}_3 + \text{H}_2\text{O}$$
- (iii) What type of reaction is occurring above
- (c) Given the reaction:

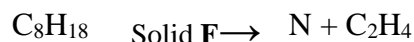

(i) Identify substance:

F..... N.....

(ii) Name the process represented above?

(d) Give **one** use of substance **N**

23. [a](i) Name another source of hydrogen apart from electrolysis of water

(iii) Write the equation for the formation of colourless gas in the reaction between ammonia gas and oxygen

(iv) Give **one** use of nitric (V) acid

(b) State and explain the observations that would be made if a sample of copper metal is heated with concentrated nitric (V) acid

24. (a) Give the systematic names of the following compounds:-

(i) $\text{CH}_2 = \text{C} - \text{CH}_3$

Br

(ii) $\text{CH}_3\text{CH}_2\text{CH}_2\text{C} \equiv \text{CH}$

(b) State the observations made when butan-1-ol reacts with:-

(i) Acidified potassium dichromate (VI) solution

(ii) Potassium metal

(c) Ethanol obtained from glucose can be converted to ethene as shown below:-



Name and describe the processes that take place in steps **I** and **II**

(d) Compounds **A** and **B** have the same molecular formula $\text{C}_3\text{H}_6\text{O}_2$. Compound **A** liberates Carbon (IV) Oxide on addition of aqueous sodium carbonate while compound **B** does not. Compound **B** has a sweet smell. Draw the possible structures of:-

(e) Give **two** ways how the disposal of polymers such as polychloroethene by burning pollutes the environment

25. [a]Alkanes,alkenes and alkynes can be obtained from crude oil.Draw the structure of the second member of the alkyne homologous series

[b]Study the flow chart below and answer the questions that follow

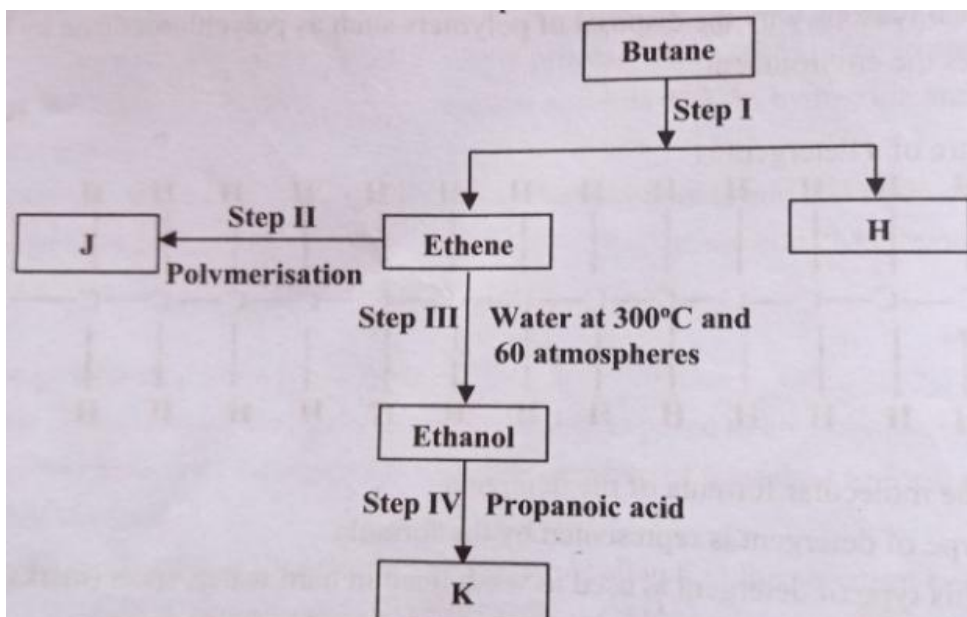

[i] State the conditions for the reaction in **step I** to occur

[ii] Identify substance **J**

[iii] The name of the process that takes place in **step III**

[iii] Give;

I. One disadvantage of continued use of substance such as **J**

II. The name of the process that takes place in step three

III. The name and the formula of the substance **K**

[iv] The relative molecular mass of **J** is 16800. Calculate the number of monomers that make up **J**

[c] The table below shows a formula of four compounds **L, M, N** and **P**.

Compound	Formula
L	C_2H_6O
M	C_3H_6
N	$C_3H_6O_2$
P	C_3H_8

Give a reason in each case, select a letter which represents a compound that;

[i] Decolourises bromine in the absence of UV light

[ii] Gives effervescence when reacted with aqueous sodium carbonate

26. The molecular formula of a hydrocarbon is C_6H_{14} . The hydrocarbon can be converted into two other hydrocarbon as shown by the equation below:

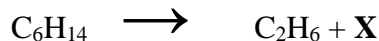

- (i) Name and draw the possible structural formula of **X**
 (ii) State and explain the observations that would be made if a few drops of bromine water were added to a sample of **X**
 (iii) Write an equation for the complete combustion of C_3H_8
27. (a) Give the names of the following
 (i) $CH_3CH_2CH_3$
 (ii) CH_3CCCH_3
 (b) Ethene is used in making polyethene bag in a process called polymerization
 (i) Name the type of polymer that is formed when ethane polymerise
 (ii) Describe a simple chemical test that can be used to identify ethane gas in the laboratory
 (c) Study the information in the table below and answer the questions that follow:-

No. of carbon atoms	R.M.M of the Hydrocarbon
2	28
3	42
4	56

- i. Write the general formula of the hydrocarbons in the table above
 ii. Determine the molecular of a hydrocarbon with 5 carbon atoms and draw its structural formula

Molecular formula
 Structural formula

- (d) Study the scheme below and answer the questions that follow

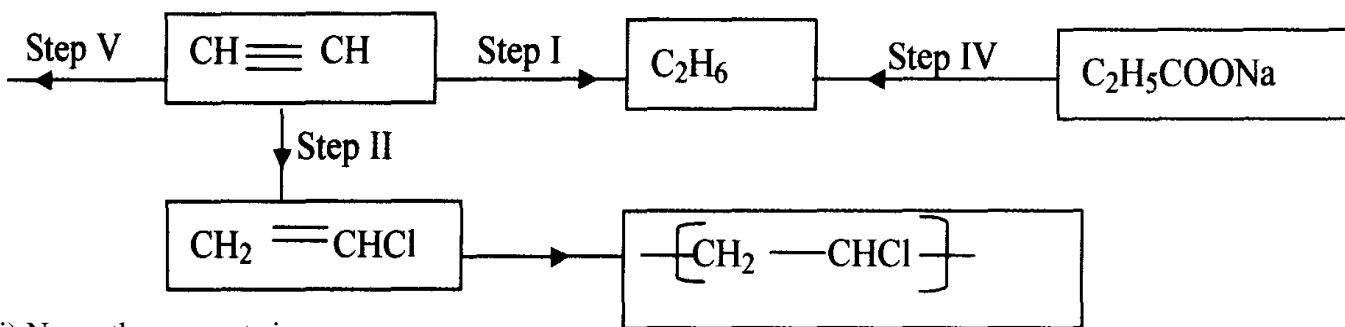

- (i) Name the reagents in
 Step I
 Step II
 Step IV
- (ii) Write an equation for the complete combustion of $CH \equiv CH$
 (iii) Give **two** uses of CH_4
28. Give the systematic names of the following compounds;
 i) $CH_3 = C - CH_3$



29. Study the data given in the following table and answer the questions that follow. The letters are not the actual symbols of elements.

Element	Number of protons	Melting point	Bpt °C
A	11	98	890
B	12	650	1110
C	13	60	2470
D	14	1410	2360
E	15	442 590	280
F	16	113 119	445
G	17	-101	-35
H	18	-189	-186

- (i) State and explain the trend in melting point in **A B C**
 (ii) Explain why the melting point and boiling points of element **D** is the highest
 (iii) Explain why the element represented by letter **E** has two melting point values
 (iv) Write down the chemical formula between element **C** and sulphate ions
 (v) Name the chemical family in which **H** belong and state one use of the element
 (vi) What is the nature of the oxide of the elements represented by letters **C** and **F**?
30. a) The table below gives information about the major constituents of crude oil. Study it and answer the questions that follow:

Constituent	Boiling point °C
Gases	Below 40
Petrol	40-175
Kerosene	175-250
Diesel	250-350
Lubricating oil	350-400
Bitumen	Above 400

- i) Which of the constituents of crude has molecules with the highest number of carbon atoms? Explain
 ii) Name the process you would use to separate a mixture of petrol and diesel and explain how the separation takes place
 iii) Explain why the constituents of crude oil do not have a sharp boiling point
 iv) Name the gas that is likely to be a constituent of crude oil and write its formula
 b) i) What condition could cause a poisonous gas to be formed when kerosene is burnt. Explain

ii) Give **one** use of bitumen

31. Study the information in the table below and answer the questions that follow

Number of carbon atoms per molecule	Relative molecular mass of the hydrocarbon
2	28
3	42
4	56

- i) Write the general formula of the hydrocarbons in the table
ii) Predict the relative atomic mass of the hydrocarbons with 5 carbon atoms
iii) Determine the relative atomic mass of the hydrocarbon in (ii) above and draw its structural formula (H=1.0, C=12.0)
32. Substance “**M**” with a general formula C_2H_y burnt in chlorine gas with a red flame producing a cloud of black specks and colourless gas **G**.
(a) State the collective name for compounds which ‘**M**’ belongs
(b) With reason, state the identity of the black specks and colour gas “**G**”.
33. 2.63g of a solution of sodium chloride at 20.0°C was reacted with silver nitrate. After filtration, washing and drying, 2.36g of silver chloride was obtained. Determine the solubility of sodium chloride at 20.0°C . (Na=23, Cl= 35.5, Ag = 108)
(b) Determine the number of moles of carbon (IV) Oxide gas produced when sodium carbonate reacted with dilute sulphuric (VI) acid (Molar gas volume = 24dm^3)
34. Write down all the isomers of but-2-ene and give their IUPAC names
35. (a) A hydrocarbon compound **Z** decolourizes bromine liquid in the presence of light but does not decolourize acidified potassium manganate (VII). Name and draw the structural formula of the eighth member of this homologous series
36. (a) What is meant by **isomerism**?
(b) Draw and name **two** isomers of Butyne

NITROGEN AND ITS COMPOUNDS

1. The apparatus below was set-up to show the catalytic oxidation of ammonia. Study the diagram and answer the questions that follow:-

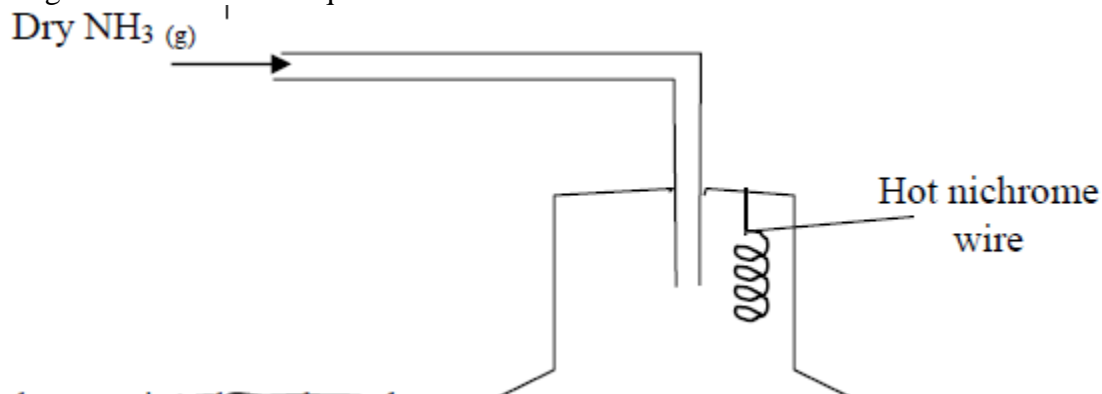

- (i) Write an equation for the reaction that takes place
- (ii) Why is it necessary to have a hot nichrome wire in the gas jar?
- (iii) Write the formula of the complex ion formed when excess ammonia gas is passed through a solution containing Zn^{2+} ions
2. The diagram below shows the catalytic oxidation of ammonia gas. Use it to answer the questions that follow:-

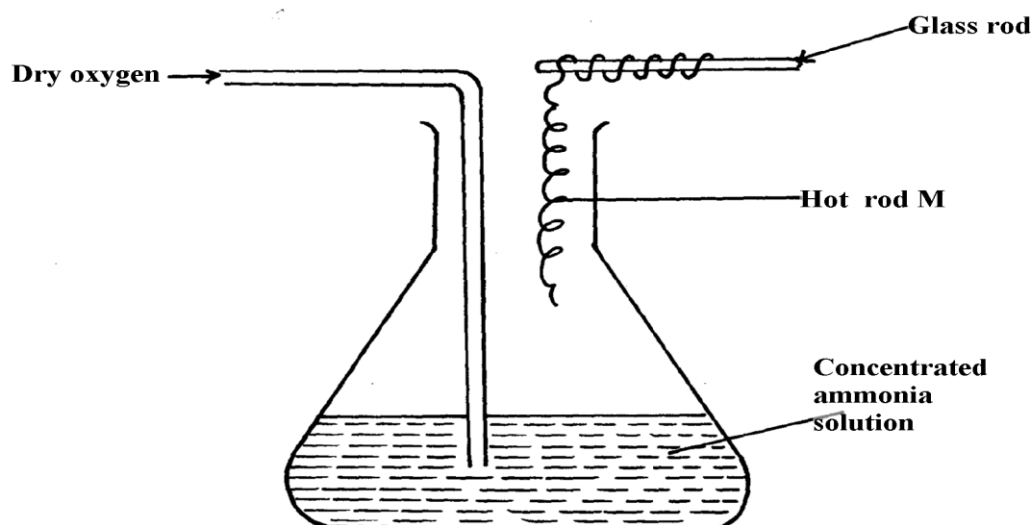

- (a) What metal could rod M be made of?

(b) State and explain **two** observations made inside the conical flask

3. Ammonia gas is prepared in the laboratory by the action of an alkali on an ammonium salt. A student wanted to prepare a sample of ammonia gas in the laboratory.

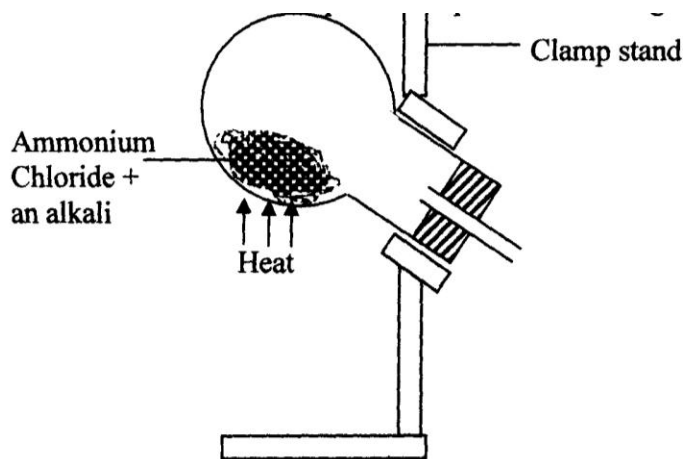

- (a) Give **one** alkali that can be used in the above experiment
(b) Write an equation for the reaction that takes place in the above experiment

4. (a) Explain the importance of the high percentage of nitrogen in air
(b) Why is nitrogen used for storage of semen in artificial insemination?

5. The diagram below is used in preparation of a gas in the laboratory. Answer the questions that follow;

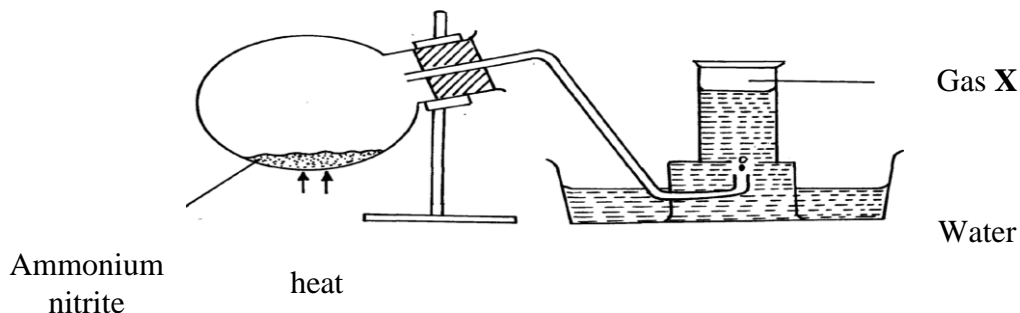

- (a) Name gas **X**
- (b) State **one** physical property which makes it possible for the gas to be collected as shown*

(c) State **one** commercial use of gas X

6 Dry ammonia and dry oxygen were reacted as shown in the diagram below

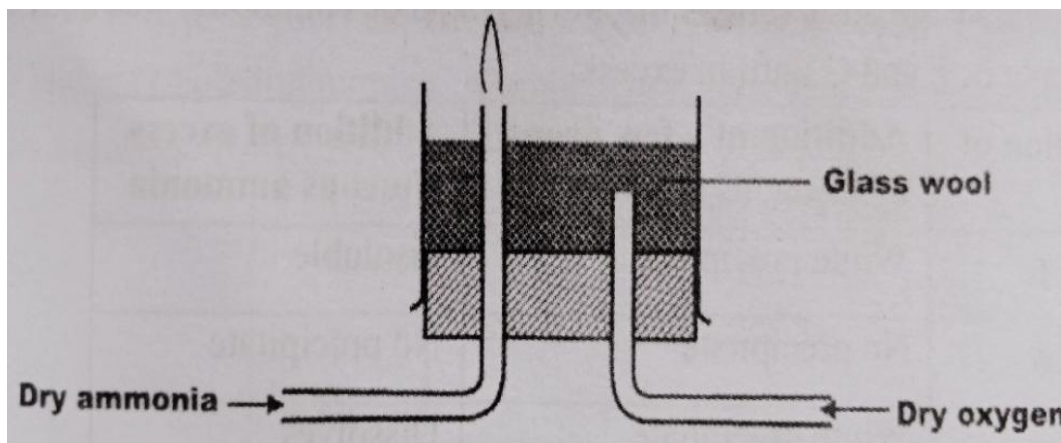

[a]What is the purpose of the glass wool?

[b]What products will be formed if red hot platinum was introduced into a mixture of ammonia and oxygen

7. The set-up below is an arrangement showing how metals react with nitrogen (IV) oxide. Study it and answer the questions that follow:-

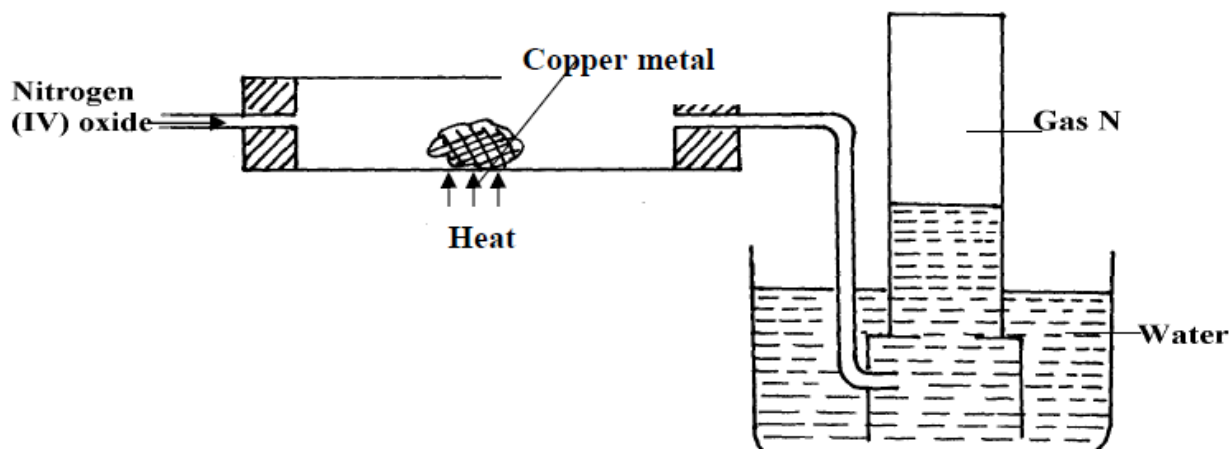

(a) Nitrogen (IV) oxide is passed through the combustion tube before copper is heated. Give a reason for this

(b) State the observations that would be made at the end of the experiment in the combustion tube

(c) Name gas N

8. (a) In haber process hydrogen and nitrogen react in the presence of finely divided iron catalyst. Explain why the catalyst is finely divided

(b) A mixture of N_2 , H_2 and NH_3 was bubbled through 0.2M hydrochloric acid solution.

The final concentration of the acid was found to be 0.1M. Give explanation

9. In an experiment, a few drops of concentrated nitric acid were added to aqueous iron [II] sulphate in a test-tube. Excess ammonia solution was then added to the mixture
- (a) State the observations that were made when:-
- Concentrated nitric acid was added to aqueous iron (II) sulphate
 - Excess ammonia was added to the mixture
- (b) Write an ionic equation for the reaction which occurred in a (ii) above
10. The chart below shows a summary for the preparation of nitrogen gas from air



- (a) What is the purpose of the sodium hydroxide?
- (b) Write an equation for the reaction taking place in chamber II
- (c) The nitrogen gas obtained is not pure. Explain
11. Dilute nitric acid is added to excess green solid. Effervescence occurs and a blue solution is formed. When excess ammonia solution is added to a sample of the solution a deep blue solution is formed
- (a) Identify the anion and cation in the green solid:
- (b) Write an ionic equation for the reaction forming deep blue solution
12. The diagram below is a set-up for preparation and collection of a gas. Study it answer the questions that follow:

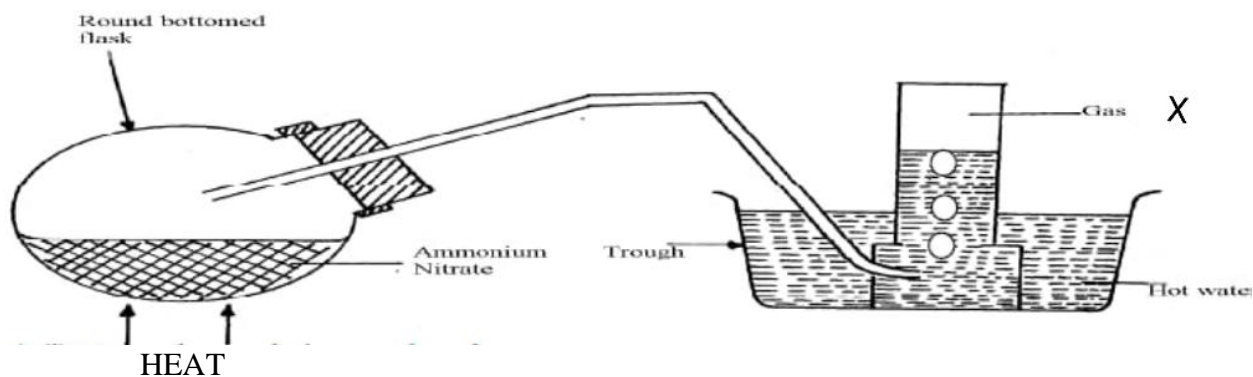

- Identify gas X
- Write an equation for the formation of gas X
- What precaution should be observed when preparing gas X by the above method?
- Describe the suitable drying agent for gas X
- How can one confirm that the gas collected is gas X?
- State **two** physical properties of gas X

(b) The diagram below is a set-up used in preparation of ammonia solution. Study it and answer the questions that follow

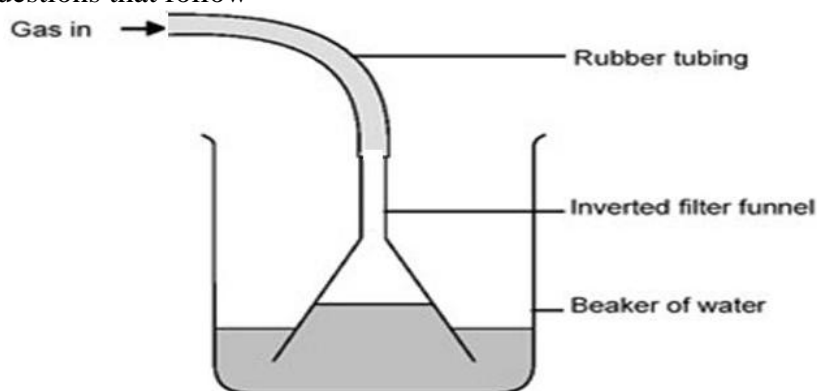

- (i) What is the purpose of the filter funnel in the set-up above?
- (ii) What would happen if a delivery tube was used in place of the filter funnel?
- (iii) What observation would be made on litmus paper placed into the solution in the beaker at the end of the experiment?

13. The following flow chart shows the industrial manufacture of Nitric (V) acid.

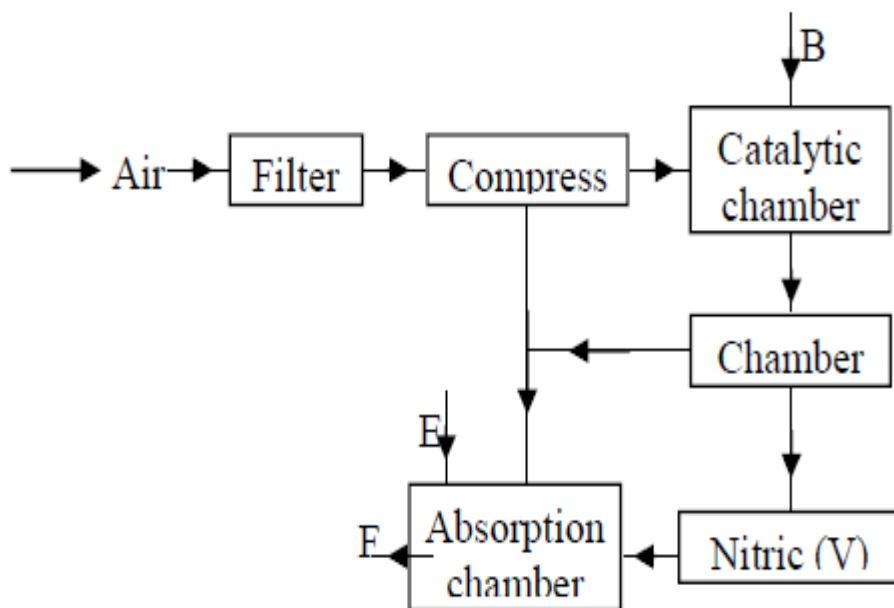

a) Identify substance **B**, **C**, **E** and **F**.

- b) Describe what happens in the catalytic chamber.
 c) State what takes place in chamber **D**.
 d) 60 – 65% nitric (V) acid is produced in the absorption chamber. Describe how the acid can be concentrated.
 e) State why nitric (V) acid is stored in dark bottles.
 f) Copper reacts with nitric (V) acid and not hydrochloric acid. Explain.

14. The flow chart below illustrates two industrial processes, **Haber** process and the **Contact** process:

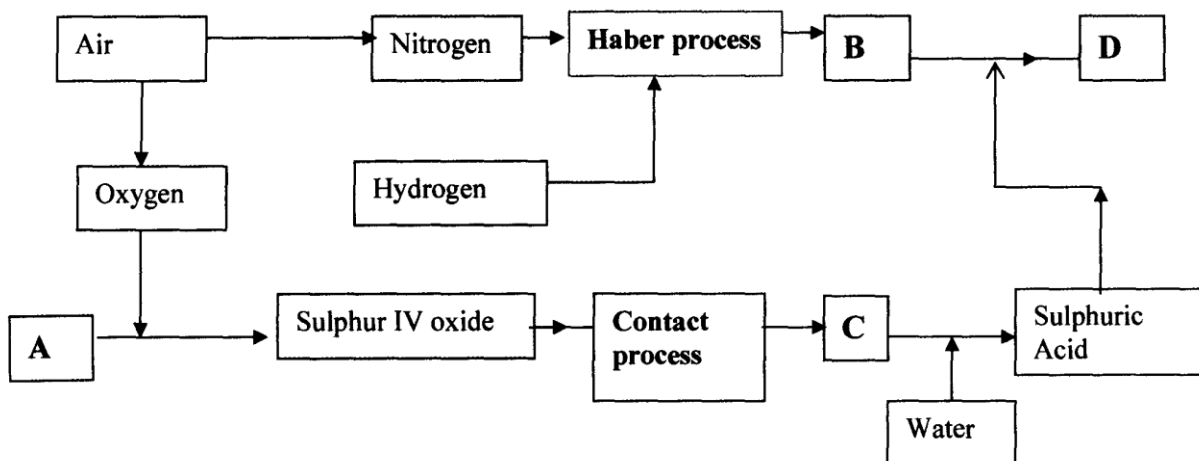

- (i) Give the name of the process by which air is separated into oxygen and nitrogen
 (ii) Apart from oxygen and nitrogen gases produced from process (a)(i) Name **one** other gas produced
 (b) Name the substances represented by the letters **A, B, C** and **E**
 (c) Name the catalysts used in:

(i) Haber Process

.....
 (ii) Contact Process

-
 (d) Explain the role of the catalysts in both the Haber and the Contact processes
 (e) Write a chemical equation for the formation of compound **B**
 (f) Calculate the percentage by mass of the nitrogen present in compound **D**
 (g) Give **one** major use of compound **E**

15. The diagram below represents a set-up used to obtain nitrogen from air. Study it and answer the questions that follow:-

Nitrogen gas

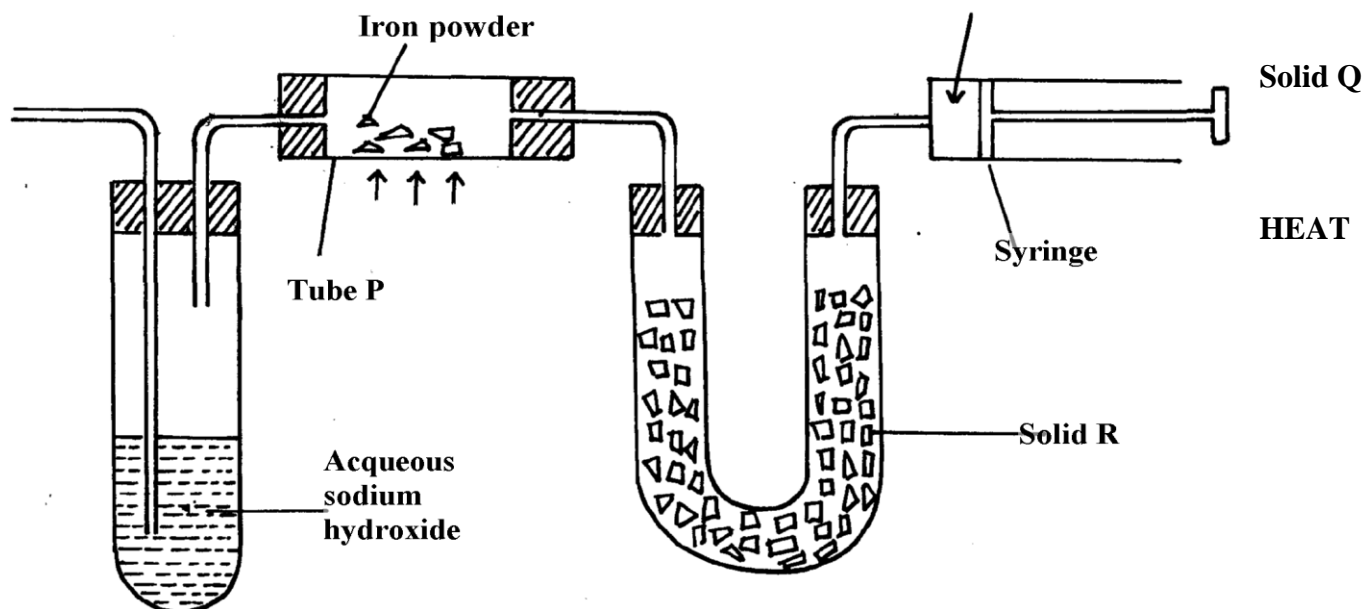

- (i) Name solid **Q**
- (ii) What is the purpose of sodium hydroxide
- (iii) Write an equation for the reaction which took place in tube "**P**"
- (iv) Give the name of **one** impurity in the nitrogen gas obtained
- (v) Give a reason why liquid nitrogen is used for storage of semen for artificial insemination

(b) The set-up below was used to prepare nitric acid.

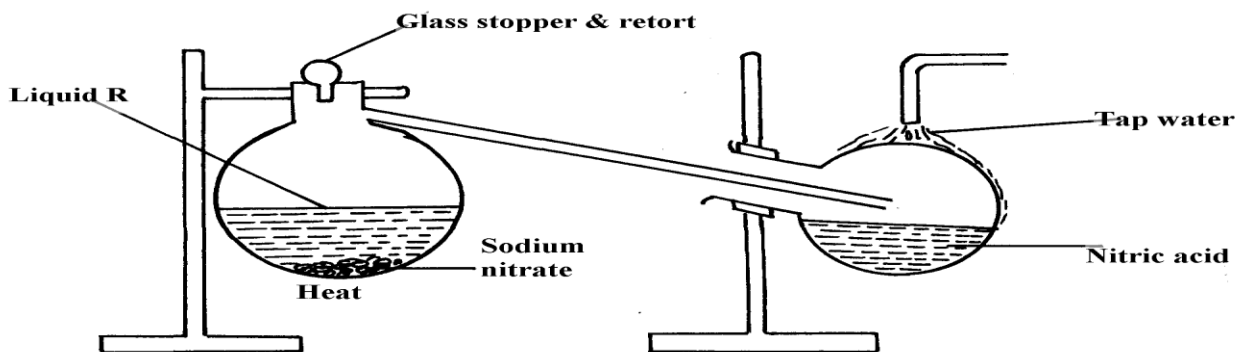

- (i) Give the name of liquid '**R**'
- (ii) Explain the following:-
 - (a) Nitric acid is stored in dark bottles
 - (b) The reaction between copper metal with 50% nitric acid in an open tube gives brown fumes

16. Study the flow chart below and answer the questions which follow:

(i) Give **one** source of the following raw materials

(s)

(a) Nitrogen gas

.....
(b) Hydrogen gas

.....
(ii) State **three** conditions required in process I

(iii) Name: catalyst **P**.....

Gas **M**.....

(iv) Write chemical equations for;

(a) Formation of gas **M**

(b) The reaction in the absorption tower

(v) Give **two** reasons why step IV is necessary

(vi) Describe how you would test if a given liquid is a nitrate

(vii) Give **three** uses of nitric acid

17. The diagram below shows the apparatus for the laboratory preparation of one of the oxides

of Nitrogen

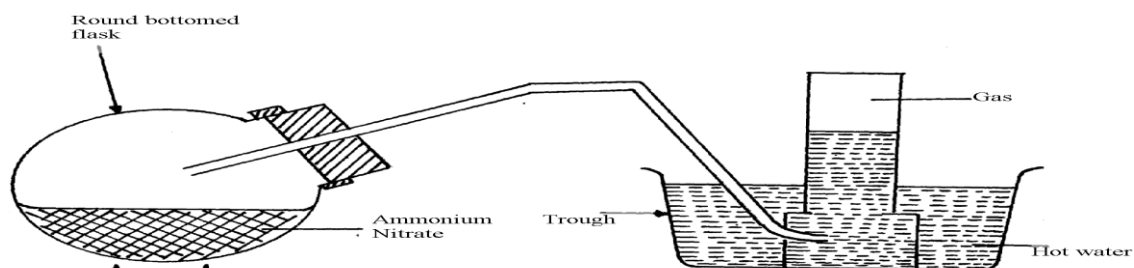

a) (i) Name the gas being produced

- (ii) Write the equation for the thermal decomposition of ammonium Nitrate
 (iii) The gas is being collected over hot water. Explain
 (iv) State and explain the observations made when burning sulphur is lowered into a gas jar containing the gas
- (b) (i) Name the catalyst used during catalytic oxidation of ammonia
 (ii) Nitrogen (IV) oxide is the final product during catalytic oxidation of ammonia.
 Write a chemical equation for its formation
 (iii) State **two** physical differences between Nitrogen (I) oxide and Nitrogen (IV) Oxide
- (c) Nitric acid is prepared in the laboratory by action of concentrated sulphuric (VI) acid on a suitable Nitrate and distilling off the Nitric acid, in all glass apparatus.
 (i) Why must the apparatus be made of glass?
 (ii) Hot concentrated Nitric acid reacts with sulphur in the equation below:-

$$S_{(s)} + 6HNO_{3(aq)} \rightarrow H_2SO_{3(aq)} + 6NO_{2(g)} + 2H_2O_{(l)}$$

 (I) Identify the species :-
 Oxidised Reduced

- (II) Pure nitric acid is colourless but the product during its preparation is usually pale Yellow. Explain

18. a) Describe the process by which oxygen can be obtained from air on large scale
 b) The concentration of the acid obtained is about 60%. How can this concentration be increased to about 65%?
 c) A factory uses nitric (V) acid and ammonia as the only reactants for the production of a fertilizer. If a mass of 9600kg of fertilizer was produced, calculate the mass of ammonia gas needed
 (N = 14, H = 1, O = 16)

19.

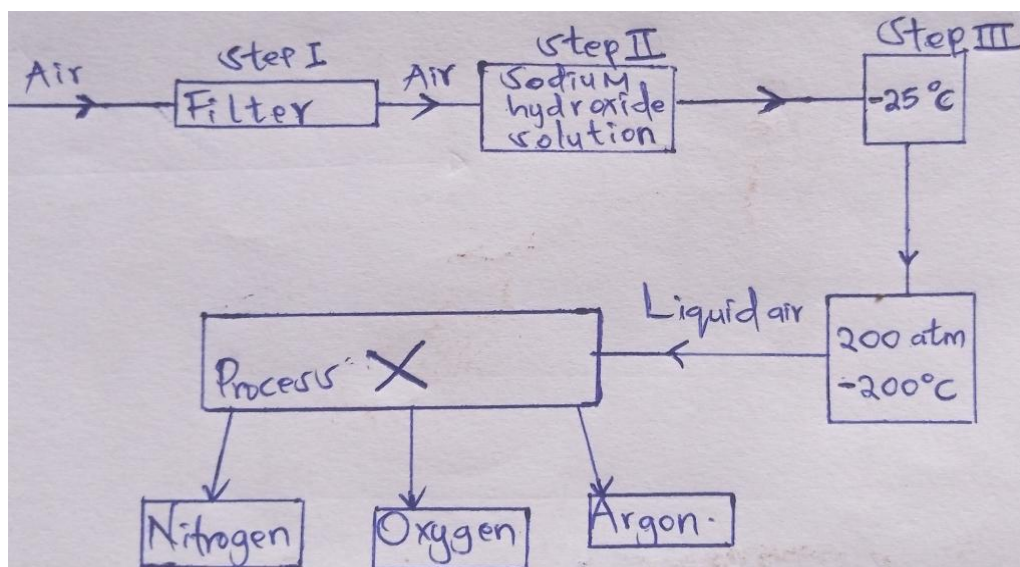

- (a) Name another substance which can be used instead of sodium hydroxide
- (b) What is the function of filters?
- (c) Identify the substance removed at **step III**
- (d) At what temperature does liquid oxygen distil?
- (e) Identify **process X**
- (f) Describe how **process X** occurs
- (g) I. State **one** industrial use of Nitrogen
- (II) Air is a mixture but not a compound. Give **two** reasons

20. Using chemical equations show the bleaching actions of chlorine and sulphur(IV)oxide

21. The diagram below represents an incomplete set-up for preparation of a dry sample of gas R

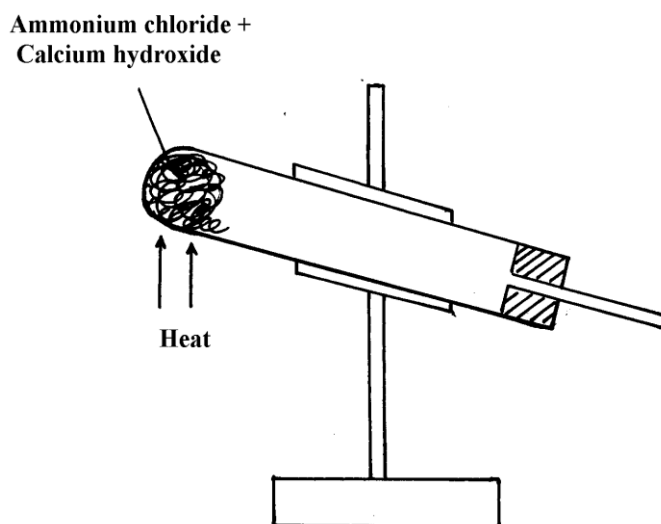

- a) Complete the set-up to show how a dry sample of gas **R** is collected
- b) Write a chemical equation for the reaction that produces gas **R**

22. The diagram below was used to investigate the reaction between nitrogen(I)oxide and Copper turnings. Study it and answer the questions that follow:

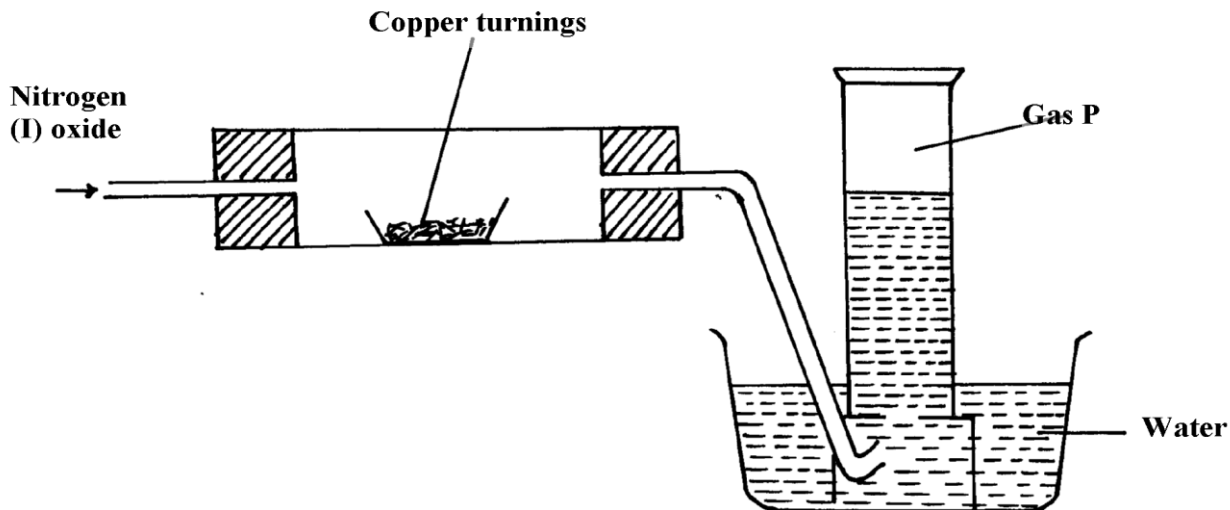

- a) What has been omitted in the set-up? (show it on the diagram)
 b) Write a chemical equation for the reaction that took place in the combustion tube
 c) State **one** use of gas **P**
23. When sulphur powder is heated to over 400°C the following changes are observed:-
 At 113°C it melts into light brown liquid. The liquid then darkens to become reddish-Brown and very viscous at 160°C. Above 160°C the liquid becomes almost black. At the boiling point the liquid becomes mobile. Explain these observations
24. Concentrated sodium chloride (Brine) was electrolysed using platinum electrodes. What would be the difference in terms of products at each electrode if dilute sodium chloride solution was used in place of brine. Explain
25. (i) Nitrogen (I) Oxide supports, combustion of burning charcoal. Write an equation to show this reaction
 (ii) Ammonium nitrate can be heated to give off nitrogen (I) Oxide. However, a mixture of NH_4Cl and NaNO_3 is preferred. Explain
 (iii) Ammonia turns wet red litmus paper blue. Which ion is responsible for this reaction
26. [a] Give a reason why concentrated sulphuric [vi] acid is not used to dry ammonia gas
 [b] Name one suitable drying agent for ammonia gas
27. When a few drops of aqueous ammonia were added to a colourless solution **X**, a white precipitate was formed. On addition of more aqueous ammonia, the white precipitate dissolved to a colourless solution **Q**
 (a) Name the white precipitate formed
 (b) Write formula of the complex ion present in the colourless solution **Q**
 (c) Write an ionic equation for the formation of the white precipitate
28. The first step in the industrial manufacture of nitric acid is the catalytic oxidation of ammonia gas.
 a) What is the name of the catalyst used?
 b) Write the equation for the catalytic oxidation of ammonia gas.
 c) Nitric acid is used to make ammonium nitrate. State **one** use of ammonium nitrate.
29. Explain what is observed when ammonia gas is bubbled into Copper (II) sulphate solution till in excess.
30. (a) State the conditions under which nitrogen react with hydrogen to form ammonia during Haber process
 (b) When dry ammonia gas is passed over hot copper (II) Oxide, a shiny brown residue and a colourless droplets are formed. Explain these **two** observations

31. Study the flow chart below and answer the questions that follow

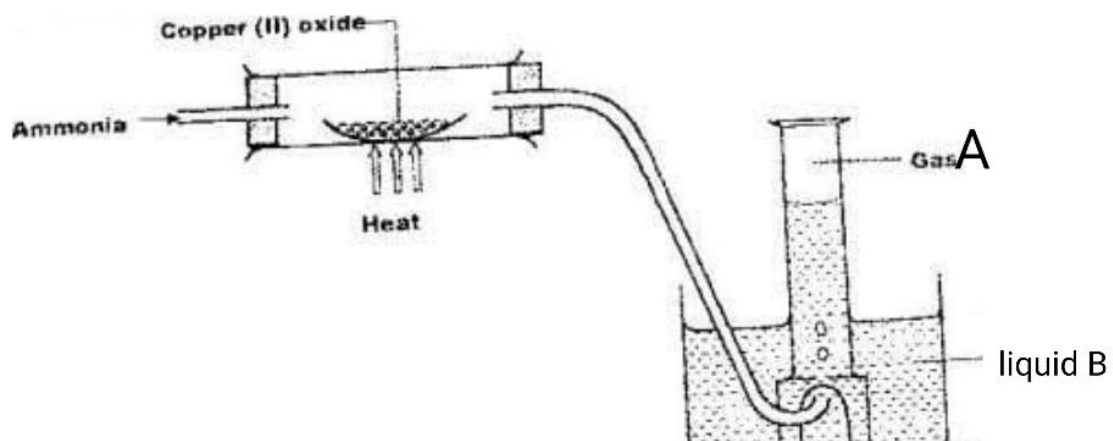

(a) State the observation made when ammonia is passed over heated Copper (II) Oxide

(b) Identify:-

(i) Gas **A**

(ii) Liquid **B**

SULPHUR AND ITS COMPOUNDS

1. Sulphur is extracted from underground deposits by a process in which three concentric pipes are sunk down to the deposits as shown below

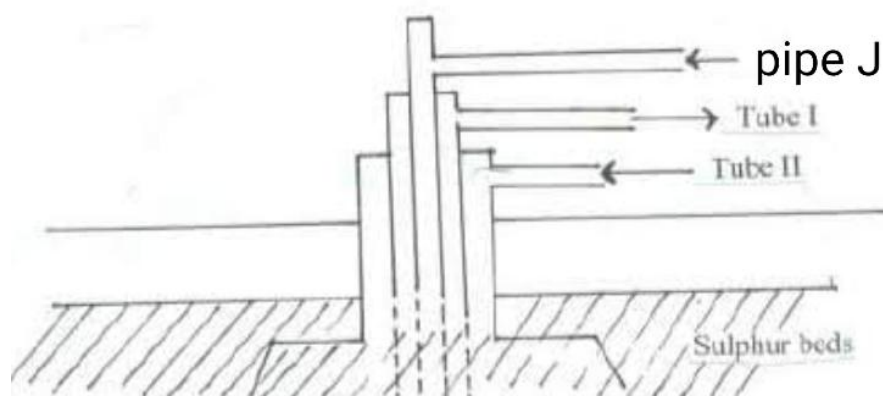

- (a) Name the process represented above
 - (b) What is passed down through pipe J?
 - (c) Name the **two** allotropes of sulphur
2. Commercial sulphuric acid has a density of 1.8gcm^3 .
 - (a) Calculate the molarity of this acid
 - (b) Determine the volume of commercial acid in (a) above that can be used to prepare 500cm^3 of $0.2\text{M H}_2\text{SO}_4$ solution
 2. Oleum ($\text{H}_2\text{S}_2\text{O}_7$) is an intermediate product in the industrial manufacture of sulphuric acid
 - (a) How is oleum converted into sulphuric (IV) acid?
 - (b) Give **one** use of sulphuric acid
 4. Differentiate between the bleaching action of chloride and sulphur (IV) oxide gas.
 5.
 - (i) Is concentrated sulphuric acid a weak acid or a strong acid?
 - (ii) Explain your answer in (i) above.
 6. In the manufacture of sulphuric acid, sulphur (IV) oxide is oxidized to sulphur (VI) oxide.
 - a) Name the catalyst used

- b) Write the equation representing the conversion of sulphur (IV) oxide to sulphur(VI)oxide
- c) Explain using equations how dilute sulphuric acid is finally obtained from sulphur (VI) oxide
7. When a mixture of concentrated sulphuric acid and copper turnings is strongly heated, a colourless gas and solid mixture of white and black solids are formed. When this solid mixture is treated with distilled water, and filtered, a blue solution and black solid residue are collected. Explain the observations on the solid mixture formed in the above experiment
8. The set-up below is used to prepare dry sulphur (IV) Oxide in the laboratory. Answer questions that follow:

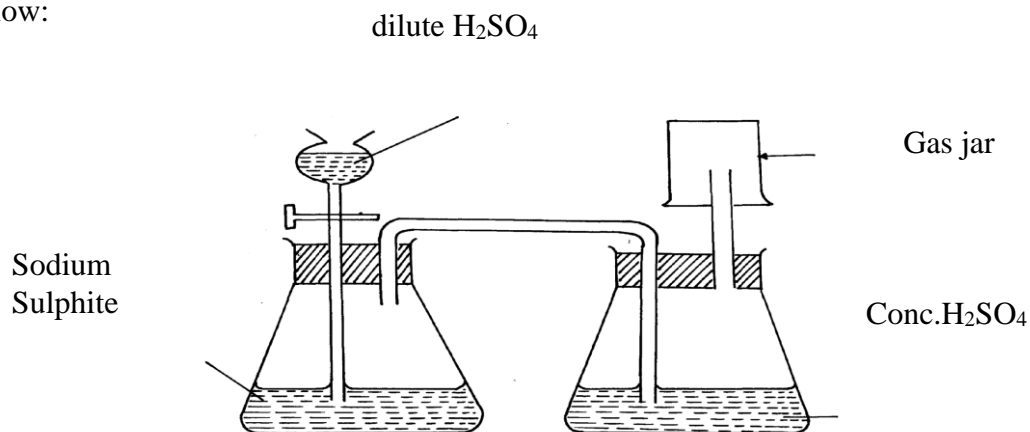

- (a) Identify the mistake in the set-up
- (b) Write an equation for the reaction in the set-up
- (c) State how the polluting effects of the gas on the environment can be controlled
9. (a) State the observation made at the end of the experiment when a mixture of iron powder and sulphur are heated in a test-tube
- (b) Write an equation for the reaction between the product in (a) above and dilute hydrochloric acid
- (c) When a mixture of iron powder and sulphur is heated it glows more brightly than that of iron fillings and sulphur. Explain this observation
10. (a) Name **one** reagent that can be reacted with dilute hydrochloric acid to produce Sulphur (IV) oxide
- (b) What would be observed if moist blue litmus paper is dropped into a gas jar of sulphur (IV) oxide? Explain your answer with an equation
11. (a) State **two** properties that vulcanized rubber possesses as a result of vulcanization
- (b) During Frasch process molten sulphur flows out through the middle pipe but not through the outer pipe. Give a reason
12. (a) Give **two** reasons why during the manufacture of sulphuric (VI) acid, sulphur (VI) Oxide,

- is dissolved in concentrated Sulphuric (VI) acid instead of dissolving in water
- b) State **one** use of sulphuric (VI) acid
13. The diagram below may be used to react hydrogen sulphide and sulphur (IV) oxide. Study it and answer the questions that follow:-

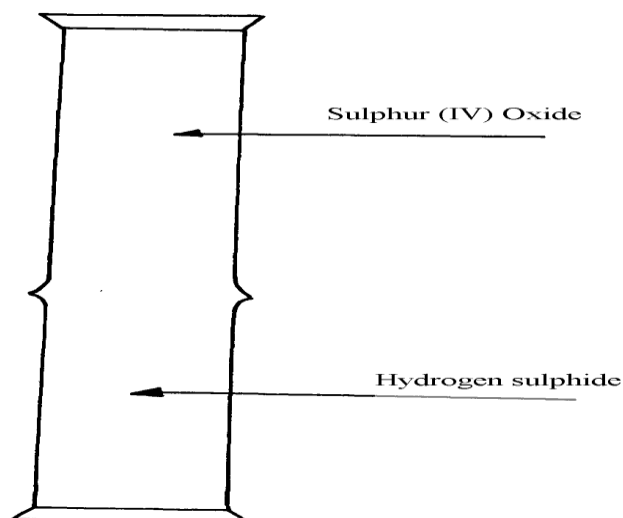

- (a) What is observed in the jars
- (b) Write an equation for the reaction
- (c) What is the role of sulphur (IV) oxide in the reaction
14. The diagram below shows the extraction of sulphur by Frasch process.

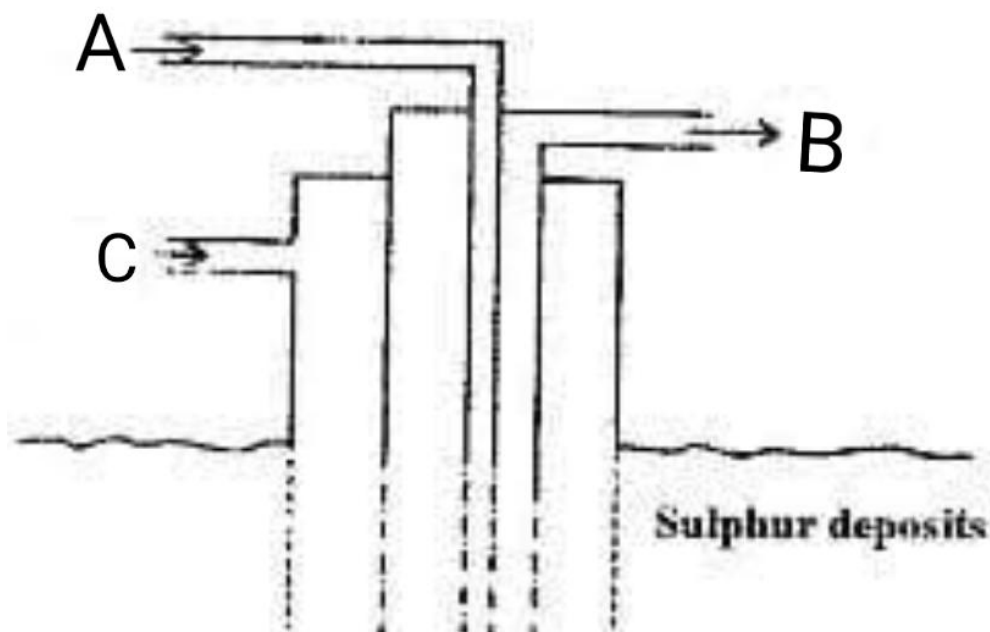

- a) State the uses of pipes A, B and C.

- b) Give **two** crystalline allotropes of sulphur.
- c) Write an equation for the combustion of sulphur.
- d) Name the product formed when a mixture of sulphur and Iron is heated.
- e) Give **two** uses of sulphur.
- f) 6.0 dm^3 of sulphur (IV) oxide were oxidized by oxygen to sulphur (VI) oxide.
- Write an equation for the reaction.
 - Calculate the number of moles of sulphur (IV) oxide and oxygen used at R.T.P.
 - Determine the volume of oxygen used.

(Molar volume of a gas at R.T.P. is 24.0 dm^3)

15. The diagrams below represent two allotropes of Sulphur. Study them and answer the questions which follow:-

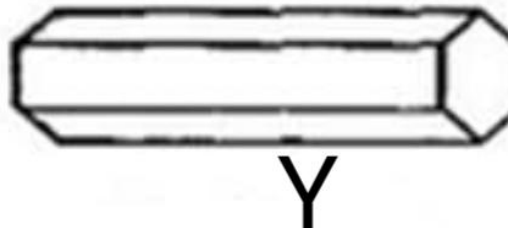

- Name the **two** allotropes labelled **X** and **Y**
 - (I) Explain why a piece of burning magnesium continues to burn in a gas jar of Sulphur (IV) Oxide
 - (II) Explain how one of the products formed in (I) above can be obtained from the mixture
16. (a) (i) Name the **two** crystalline forms of sulphur
- (ii) Briefly explain how plastic sulphur is formed
- (c) The scheme below represents the steps followed in the contact process. Study it and answer the questions that follow:-

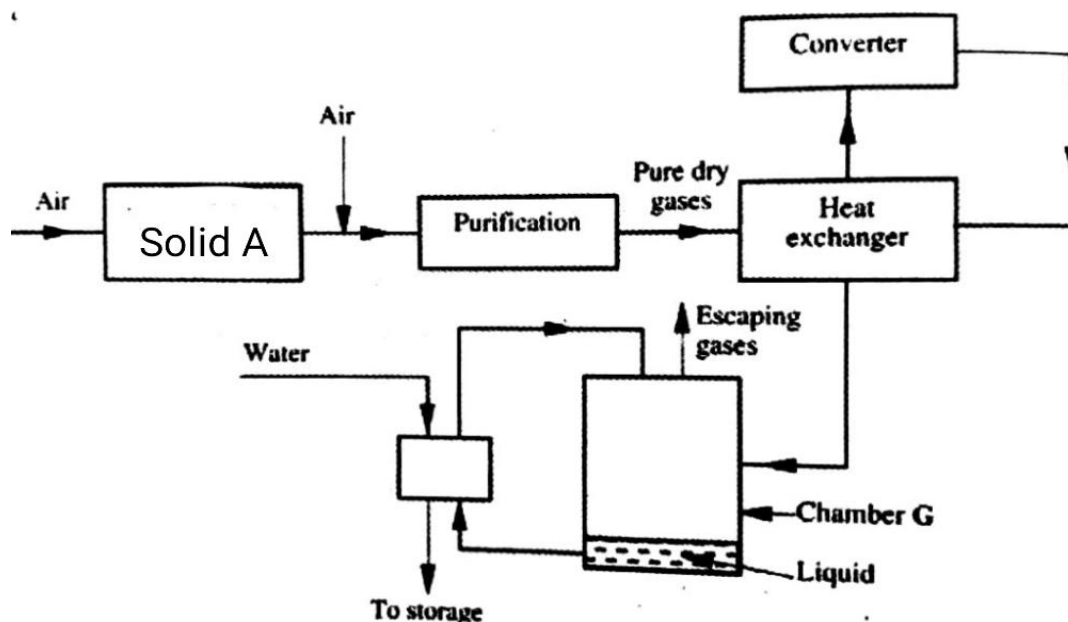

- Name **two** possible identities of solid A
- Name **one** impurities removed by the purifier
- Why is it necessary to remove impurities?
- Write down the equation of the reaction taking place in the converter
- (I) Name the **two** catalysts that can be used in the converter
(II) What is the function of heat exchanger?
- Sulphuric (VI) Oxide is not dissolved directly into water? Explain
- (I) Name the main pollutant in the contact process.
(II) How can the pollution in (g) (I) above be controlled?
- Give **one** use of sulphuric (VI) acid

7. The set-up below was used to prepare dry sample of hydrogen sulphide gas

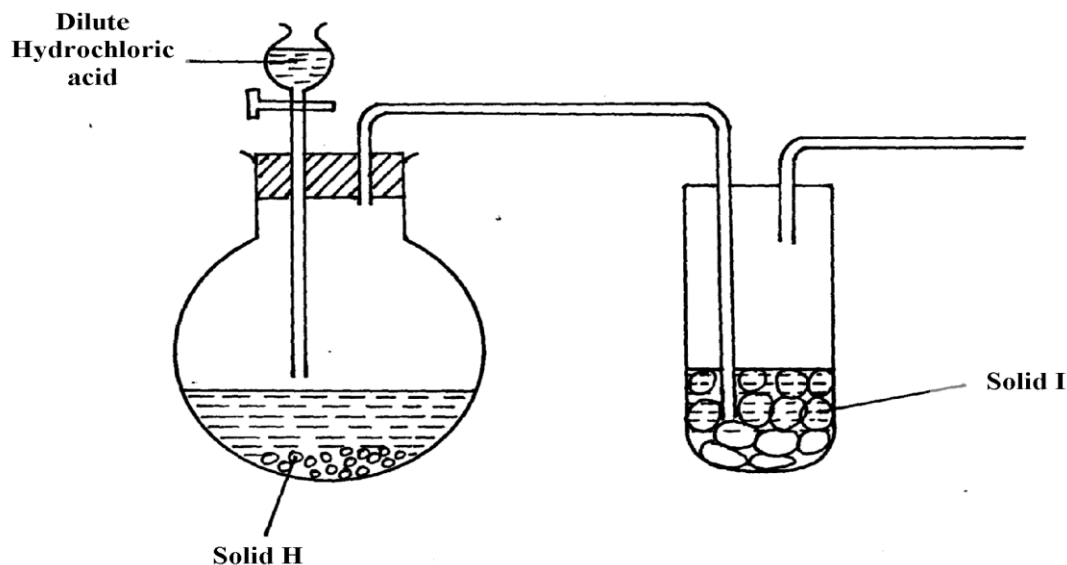

- (a) (i) Complete the diagram to show how the gas was collected
(ii) Identify the following:-
I. Solid H
II. Solid I
- (iii) Write an equation for the reaction that occurred in the flask between solid **H** and dilute Hydrochloric acid
- (b) When hydrogen sulphide gas was passed through a solution of Iron (III) chloride, the following observations were made:-
(i) the colour of the solution changed from reddish-brown to green and
(ii) a yellow solid was deposited. Explain the observation
- (d) In the manufacture of Sulphuric (VI) acid by contact process sulphur (IV) oxide is made to react with air to form sulphur (VI) oxide as shown:-



- (i) Name the catalyst in this reaction
(ii) State and explain the effect of the following changes on the yield of sulphur (VI) oxide
I. Increasing the pressure
II. Using a catalyst
(iii) Explain why sulphur (VI) oxide gas is absorbed in concentrated sulphur (VI) acid before dilution

18. Study the flow chart below and answer the questions that follow

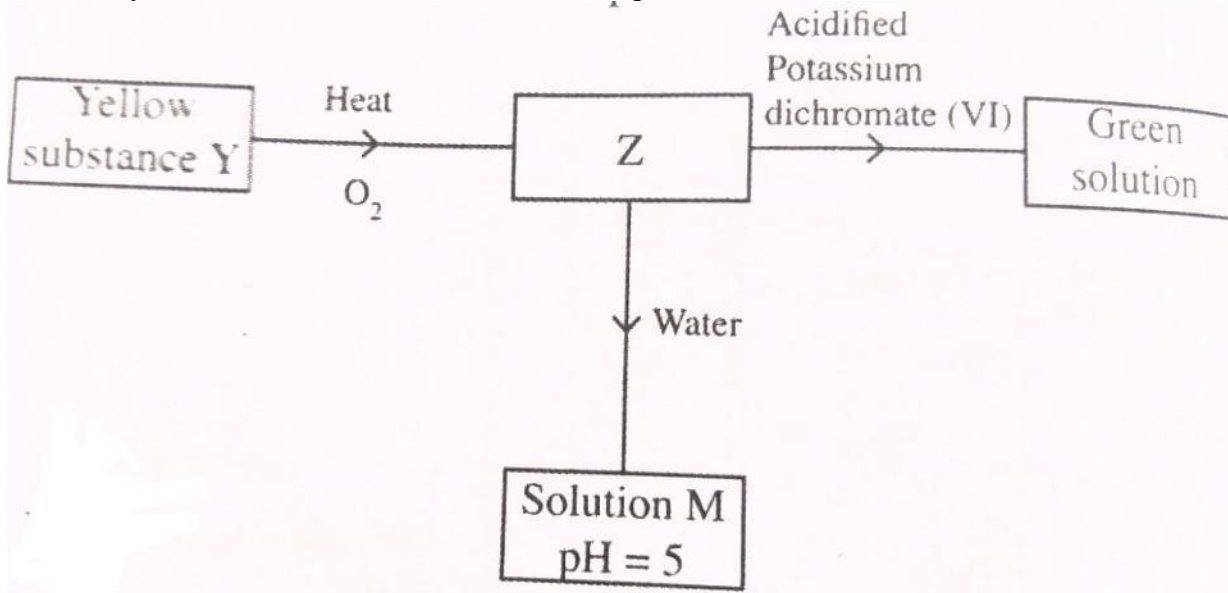

[a]Identify Z and M

(b) State and explain the harmful effects on the environment of sulphur [iv] oxide

- 19 a) Sulphur occurs naturally in two different forms called allotropes;
 i) What are allotropes

20. Study the figure below:

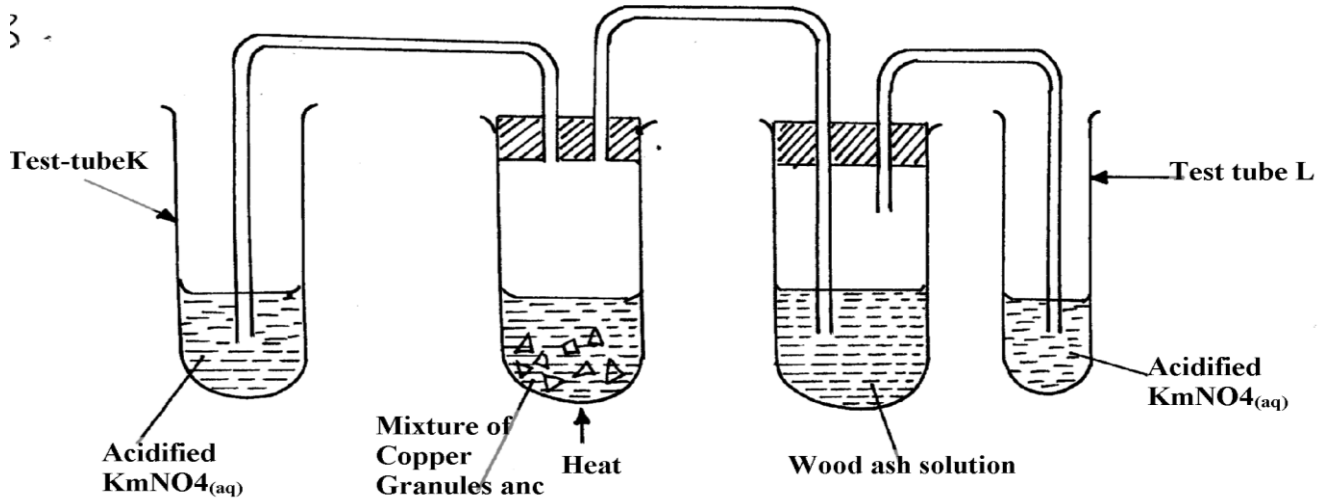

State and explain the observations made in:

Test tube L

Test tube K

21. The set-up below was used to prepare and collect hydrogen sulphide gas. Study it and answer the questions that follow:-

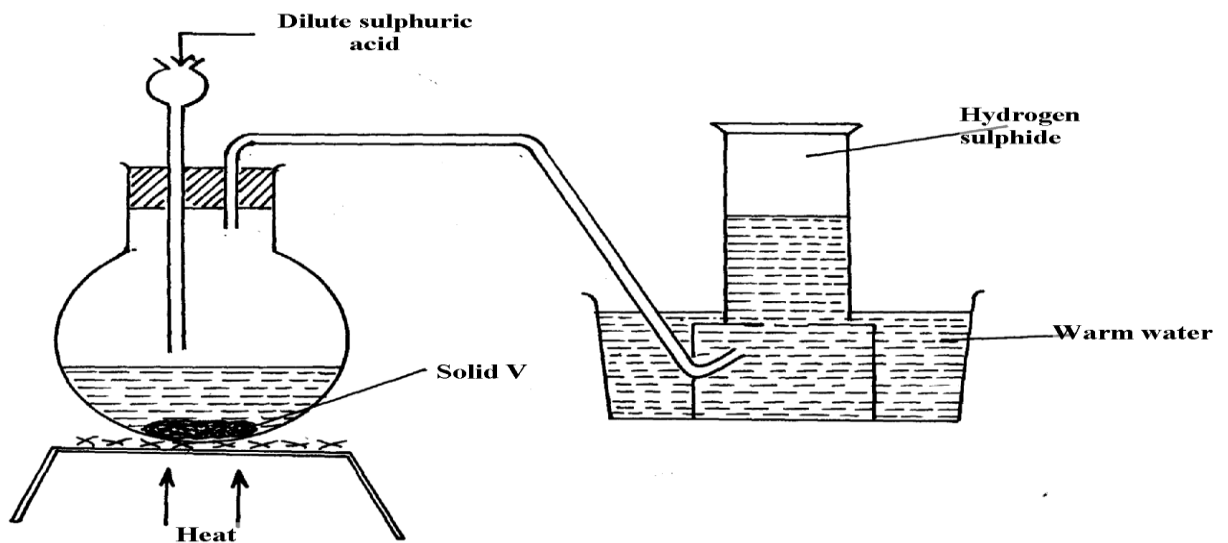

- (a) Name solid V
(b) Give a reason why warm water is used in the set-up
22. Sulphur (IV) oxide and nitrogen (II) oxide are some of the gases released from internal combustion engines. State how these gases affect the environment
23. When hydrogen sulphide gas was bubbled into an aqueous solution of Iron (III) chloride, a yellow precipitate was formed.
a) State another observation that was made.
b) Write an equation for the reaction that took place.
c) What type of reaction was undergone by hydrogen sulphide in this reaction?
24. In an attempt to prepare Sulphur (IV) Oxide gas, dilute Sulphuric acid was reacted with barium carbonate. The yield of Sulphur dioxide was found to be negligible. Explain

CHLORINE AND ITS COMPOUNDS

- (i) State **one** observation made in this experiment
(ii) Identify the substances formed in the above reaction
- Hydrogen chloride gas was passed into water as shown below:

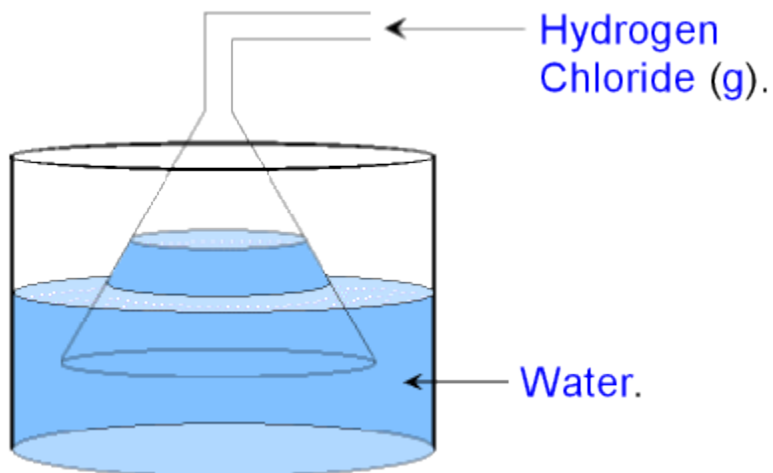

- When a blue litmus paper was dropped into the resulting solution, it turned red. Give a reason for this observation
 - What is the function of the funnel?
- A group of compounds called chlorofluoro-carbons have a wide range of uses but they also have harmful effects on the environment. State one:-
 - Use of chlorofluoro carbons
 - Harmful effect of chlorofluoro carbons on the environment.
 - a) Water from a town in Kenya is suspected to contain chloride ions but not sulphate ions. Describe how the presence of the chloride ions in the water can be shown.
 - In an experiment, chlorine was passed into moist hydrogen sulphide in a boiling tube as shown below:

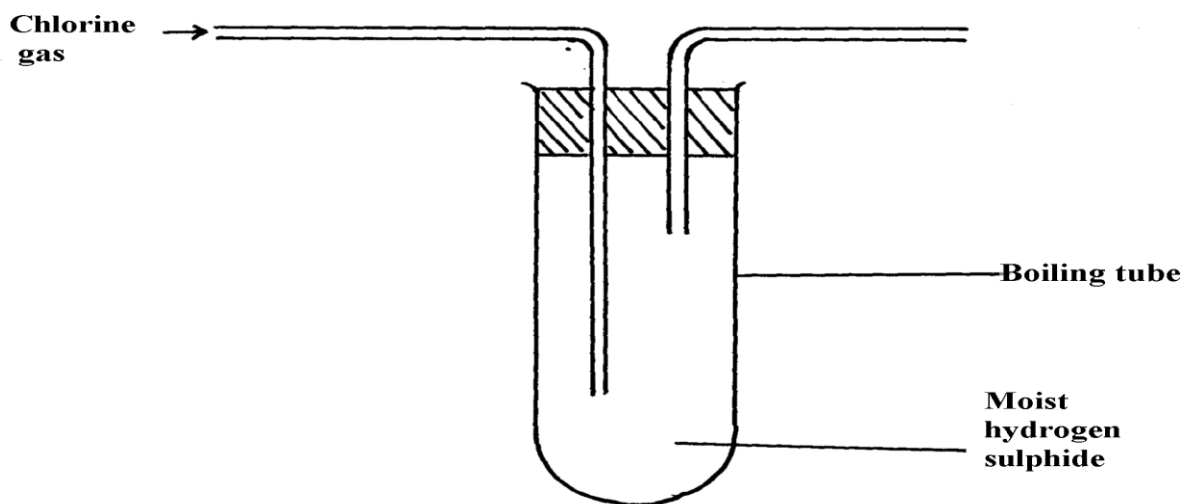

- (a) What observation was made in the boiling tube?
 - (b) Write an equation of the reaction that took place in the boiling tube
 - (c) What precaution should be taken in carrying out this experiment? Give a reason
6. Heated iron can react with both chlorine gas and hydrogen chloride gas
- i) Write equations for the reactions
 - ii) Chlorine gas has no effect on dry blue litmus paper. Explain
7. The following diagram represents a set-up that can be used in the laboratory to prepare and collect a sample of chlorine gas:

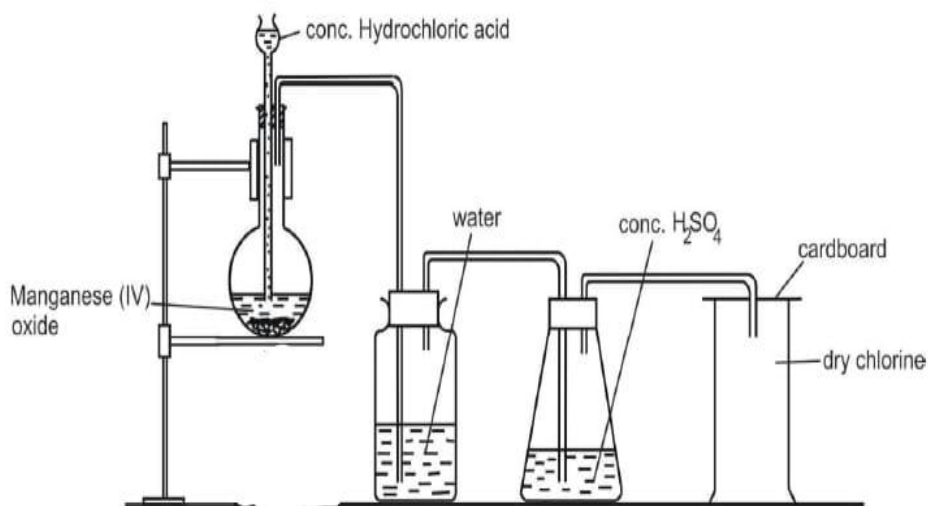

- (a) No gas bubbles were produced in the above experiment. Explain the observation
- (b) Complete the following equation

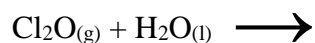

- (c) Describe the bleaching property of chlorine water
8. Study the flow diagram below and answer the questions that follow:

- (a) Write a balanced equation for the reaction between hydrochloric acid and manganese (IV) oxide
- (b) Explain what happens to coloured petals when dropped into a solution of **NaOCl**
9. Carbon (IV) Oxide, methane, nitrogen (I) Oxide and trichloromethane are green house gases
- State **one** effect of an increased level of these gases to the environment
 - Give **one** source from which each of the following gases is released to the environment;
 - Nitrogen (I) Oxide
 - Tricholomethane
10. (a) Two reagents that can be used to prepare chlorine gas are manganese (IV) oxide and concentrated hydrochloric acid.
- Write an equation for the reaction
 - Give the formula of another reagent that can be reacted with concentrated hydrochloric acid to produce chlorine gas
 - Describe how the chlorine gas could be dried and collected in the laboratory

(b) In an experiment, dry chlorine gas was reacted with aluminium as shown in the diagram below

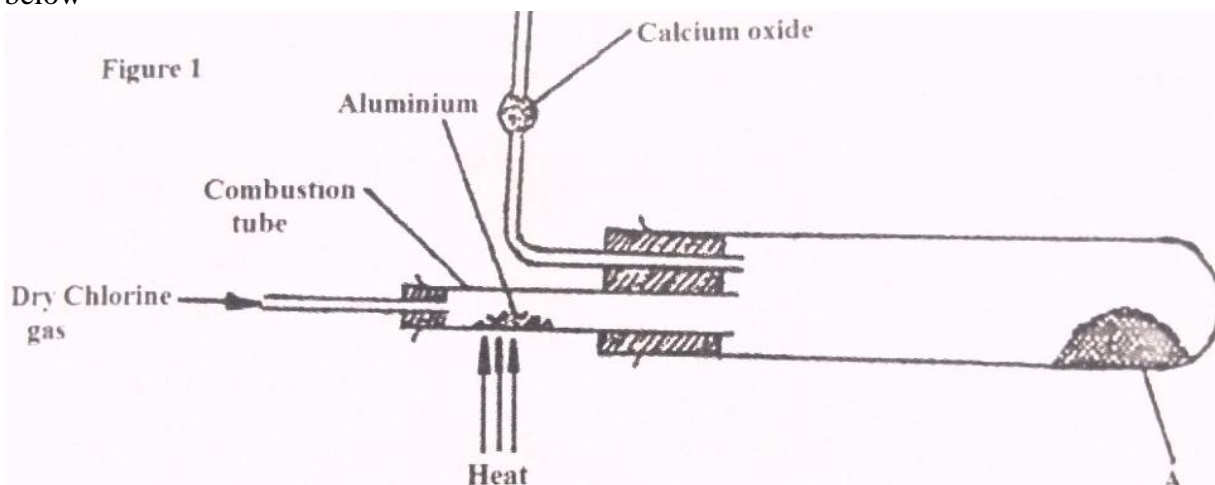

- Name substance A
- Write an equation for the reaction that took place in the combustion tube
- State the function of the calcium chloride in the set-up above

11. The figure below was set by a student to investigate the reaction between chlorine gas and hydrogen gas:

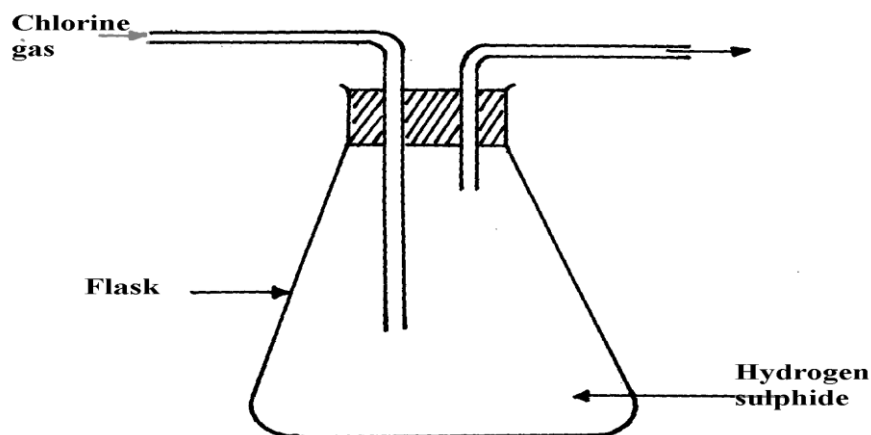

- (a) Write an equation for the reaction that took place in the flask
(b) What observation was made in the flask?
(c) What precaution should be taken in carrying out the experiment?
- ✓1
12. In an attempt to prepare a gas, Sabulei added concentrated hydrochloric acid to Potassium manganate. The products were then passed through two wash bottles containing water and concentrated sulphuric acid
- (a) Name the gas prepared.....
(b) Name the purpose of wash bottle:
(i) Containing water?
(ii) Containing concentrated sulphuric acid?
13. (i) Name **one** drying agent for hydrogen Chloride
(ii) State and explain the observation that would be made when hydrogen Chloride gas is bubbled into a solution of Silver nitrate