

F3 TOPICAL REVISION BIOLOGY

***A SERIES OF TOPICAL QUESTIONS IN FORM
THREE BIOLOGY***

***FOR MARKING SCHEMES
CALL/WHATSAPP 0705525657***

MR ISABOKE 0705525657

1.ECOLOGY

1. A student wanted to estimate the number of grasshoppers in 5km² grass field near the school compound.

Using a sweep net he captured 36 grasshoppers. He used a red felt pen to mark the thorax of each insect before releasing back into the field. Three days later he made another catch of grasshoppers. He collected 45 grasshoppers of which only 4 had been marked with red mark.

- a) Name the above method used in the population estimation
 - b) Calculate the population of grasshoppers using the above data
2. What is the significance of the following in the ecosystem?
 - a) Decomposers
 - b) Predators
 3. Birds feed on grasshoppers that feed on grass.
 - a) Draw a possible food chain from the above information
 - b) Explain why the biomass of organisms decreases at each preceding trophic level.
 4. Define the following terms:-
 - (i) Autecology ;
 - (ii) Biomass;
 5. State **two** most important factors that favour exponential growth of a population of gazelle in a park
 6. (a) Distinguish between habitat and niche.
(b) Explain why Biomass of producers is greater than that of primary consumers in a balanced ecosystem.
(c) State **two** advantages of a biological control method over the chemical control method of pests and parasites
 7. Explain how oil as a pollutant may affect aquatic plants and animals?
 8. [a]Name the organism that;
 - [i]Causes Malaria
 - [ii]Transmits malaria[b]State two control measures of Malaria

9. [a]State the effects of dumping untreated sewage into the river
 [b]Name one process that is responsible for loss of energy from one trophic level to the next
10. 50 black mice and 50 white mice were released in an area inhabited by a pair of owls. After four months, the mice in the area were recaptured and only 38 black mice and only a white mice remained.
- (a) How would you explain these results?
 (b) Name the theory of evolution that support the results in (a) above
11. In a certain school Form three class did an experiment to estimate the number of Tilapia in their fish pond. 725 tilapia were netted marked and released.
- a) State the method used in this exercise
 b) Calculate the tilapia population.
 c) State **two** assumptions made by the students during the investigation
12. An investigation was carried out on a terrestrial ecosystem. The population sizes and species biomass were determined and recorded as shown in the table

SPECIES	POPULATION SIZE	SPECIES BIOMASS
A	1×10^3	1×10^3
B	1×10^3	1×10^{-1}
C	1×10^5	1×10
D	1×10	1×10^4

- a) If these organisms had a feeding relationship, construct a simple food chain involving all the organisms
 b) Construct pyramid of numbers using the data provided above
 c) State **one** disadvantage of using pyramid of number in expressing feeding relationships in ecological ecosystem
13. The figure represents a feeding relationship in an ecosystem

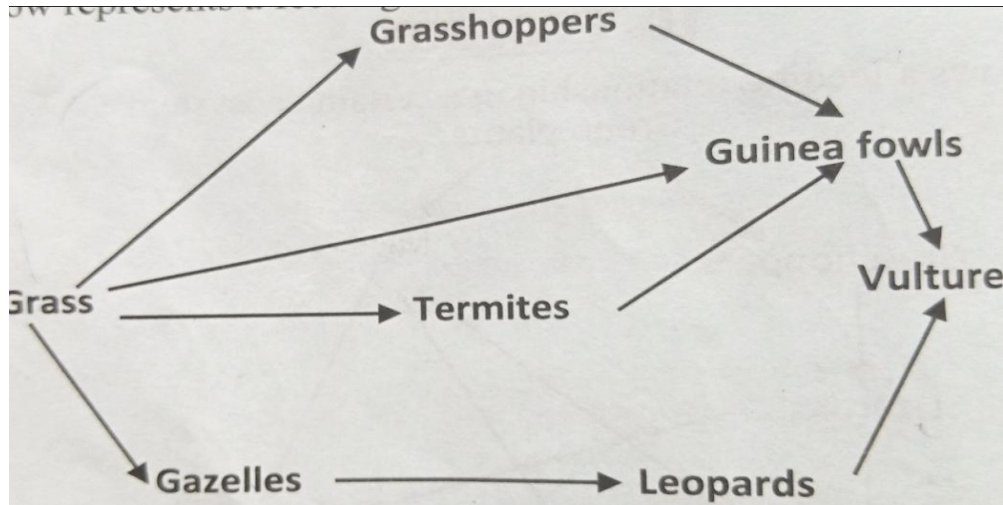

- (a) Write down the food chain in which the Guinea Fowls are secondary consumers
- (b) What would be the short term effects on the ecosystem if lions invaded the area
- (c) Name the organism through which energy from the sun enters the food web
14. Outline **three** roles of active transport in human body
 15. Distinguish between community and population
 16. Describe how the belt transect can be used in estimating the population of a shrub in a grass land
 17. A fish farmer wanted to know the number of fish in a pond. He collected 10 fish from the pond and labeled each, by a tag label on its fin and returned the ten fish to the pond to mix with other fish. When he later collected 50 fish from the pond, he found only four of them had labels
 - a) Estimate the total number of fish in the pond (show your workings)
 - b) What **two** assumptions are being made in this methods of estimating population
 18. What is the importance of saprophlic fungi and bacteria in an ecosystem
 19. i) Name **one** main cause of global warming
ii) What are the effects of global warming
 20. Explain how saliva is important in digestion
 21. Give a reason why two species in an ecosystem cannot occupy the same niche
 22. Below is a pyramid of numbers indicating trophic levels:-

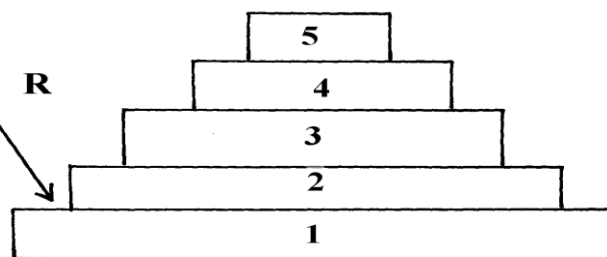

- (a) What do you understand by the term trophic level?
- (b) Name the trophic level numbered 5 on the pyramid
- (c) Name **Q**
- (d) What is the significance of the arrow **R**
23. Two populations of the same species of birds were separated over a long period of time by an ocean. Both populations initially fed on insects only. Later, it was observed that one population fed entirely on fruits and seeds, although insects were available. Name this type of evolutionary change
24. To estimate the population size of crabs in a certain lagoon, traps were laid at random. 400 crabs were caught, marked and released back into the lagoon. Four days later, traps were laid again and 360 crabs were caught. Out of the 360 crabs, 90 were found to have been marked
- (i) Calculate the population size of the crabs in the lagoon
- (ii) What is the name given to this method of estimating the population size
25. State the function of each of the following apparatus:
- (a) Pooter ...
- (b) Sweep net
26. State the role of the following apparatus in the study of living things.
- (a) Sweep nets.
- (b) Pooter.
- (c) Pit fall trap.
27. Name **three** density dependent factors in an ecosystem.
28. (a) What are the **two** main components of an ecosystem?
- (b) Apart from mere observation of actual feeding suggest **two** methods that can be used to determine the type of food eaten by animals
29. The chart below represents a simplified nitrogen cycle.

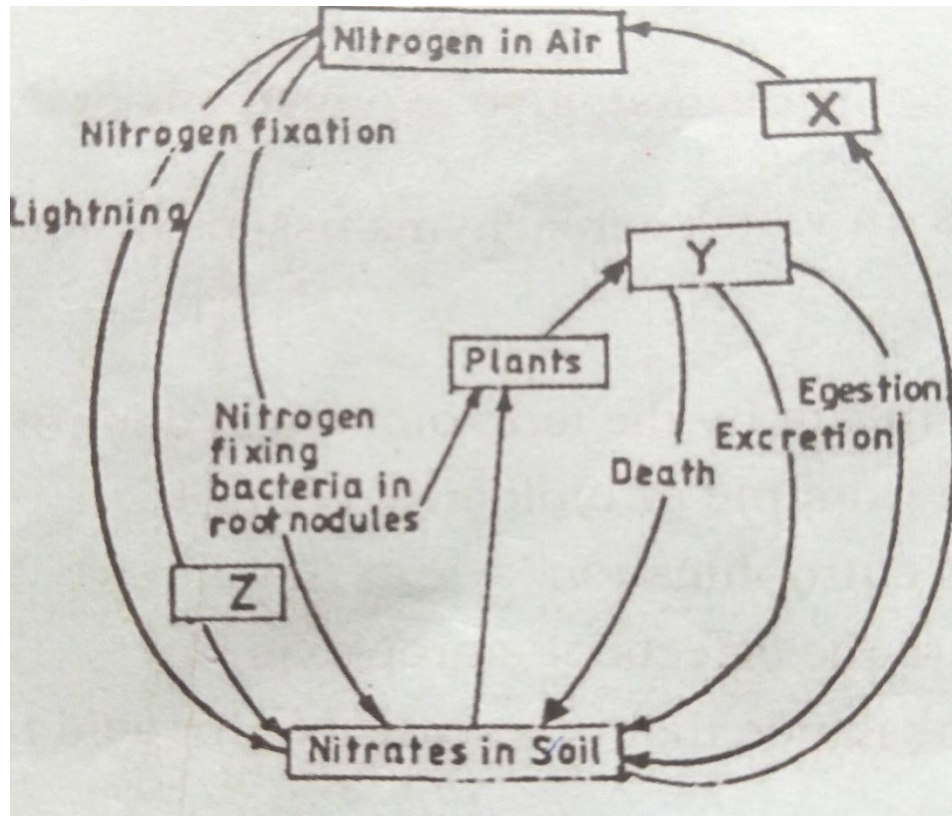

What is represented by X, Y and Z?

30. In an ecological study, a locust population and that of crows was estimated in a grassland area over a period of one year. The results were tabulated as shown below.

Months	J	F	M	A	M	J	A	S	O	N	D
No. of Adult locusts x 10 ²	90	20	11	25	200	652	15	10	35	192	456
Number of crows	4	2	0	1	8	22	2	1	1	5	15
Amount of rainfall	20	0	55	350	520	350	10	25	190	256	350

- a) Draw a graph of population of locusts and crows against time
- b) i) State the relationship between rainfall and locust population
 ii) Account for the relationship you have stated in b (i) above
- d) What happens on the populations of locusts and crows in the months of January to March? Give a reason.
- d) If the area of study was one square kilometer, state **one** method used to estimate the population of :-
 i) Locusts
 ii) Crows
- (e) (i) State the trophic levels of the (i) Locusts and (ii) crows
 (ii) Construct a simple complete food chain involving these organisms
- (f) If the locust were removed from the food chain, what would be its effect?
- (g) Define **biomass**
31. Two species of antelopes were introduced into an ecosystem at the same time in equal numbers. The graphs below show their relative numbers during the first eight years of

their co-existence. Study the graphs carefully and answer the questions that follow.

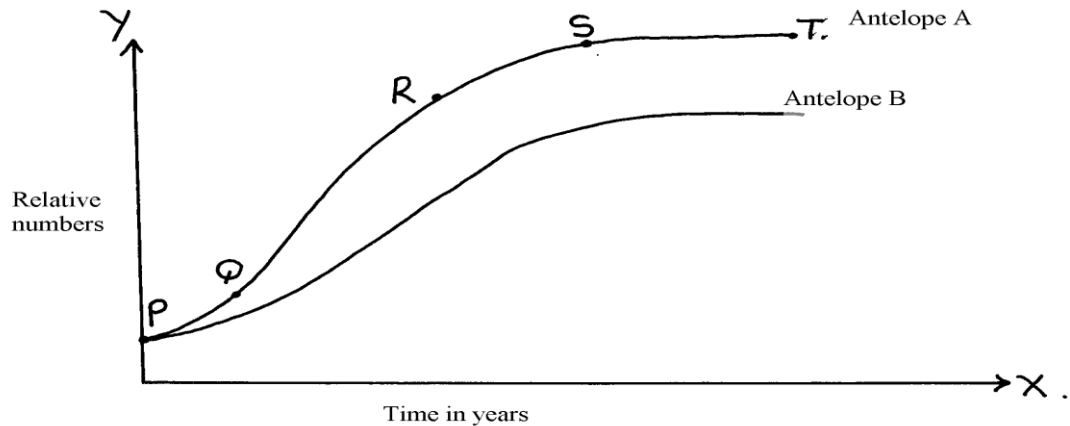

- a) i) Which species of antelope has better survival adaptations.
ii) Give a reason for your answer above.
- b) i) Name the type of curves shown.
ii) Name the phases labeled PQ, QR, RS, ST
- c) Explain the shape of the curve for the species of Antelope A between
 - i) Q and R.
 - ii) S and T.
- d) i) State the type of competition shown by the two species of antelopes.
ii) State any **two** symptoms of intraspecific competition in plants.
- e) Suggest how the species B avoid competitive exclusion..
- f) State any **three** adaptations that enable the antelopes to overcome predation.
- g) State any **two** possible methods by which populations of the two antelopes' species were determined.

32. Explain **five** abiotic factors that affect the ecosystem

33. The data shown below was taken from Savannah grassland habitat. Examine it carefully and then answer the questions that follow:-

- (a) Draw **three** food chains
- (b) Draw a pyramid of numbers for a food chain with four trophic levels and indicate the trophic levels at which each member feeds
- (c) State the effect of removing the hunting dogs
- (d) Why is it advisable to feed 100kg of grain to man instead of using it to fatten steers then supply beef to human population?

Organism	Population
Grasses	1000
Caterpillars	500
Squirrels	300
Frogs	200
Gazelles	300
Elephants	100
Snakes	50
Hunting dogs	40
Vultures	40
Lions	40
Hawks	10

34. [a][i]What is meant by the term biological control?
[i]Give an example of biological control
- [b][i]What is eutrophication?
[ii]What are the effects of eutrophication?
- [c]Name the substance that is responsible for acid rain
35. (a) Explain how food as a factor regulates the population of animals in an ecosystem
(b) Describe the flow of energy from the sun through the different trophic levels in an ecosystem
36. (a) Describe how a population of grasshoppers in a given area can be estimated
(b) Describe how the belt transect can be used in estimating the population of a shrub in a grassland
37. The flow chart below represents a feeding relationship in an ecosystem

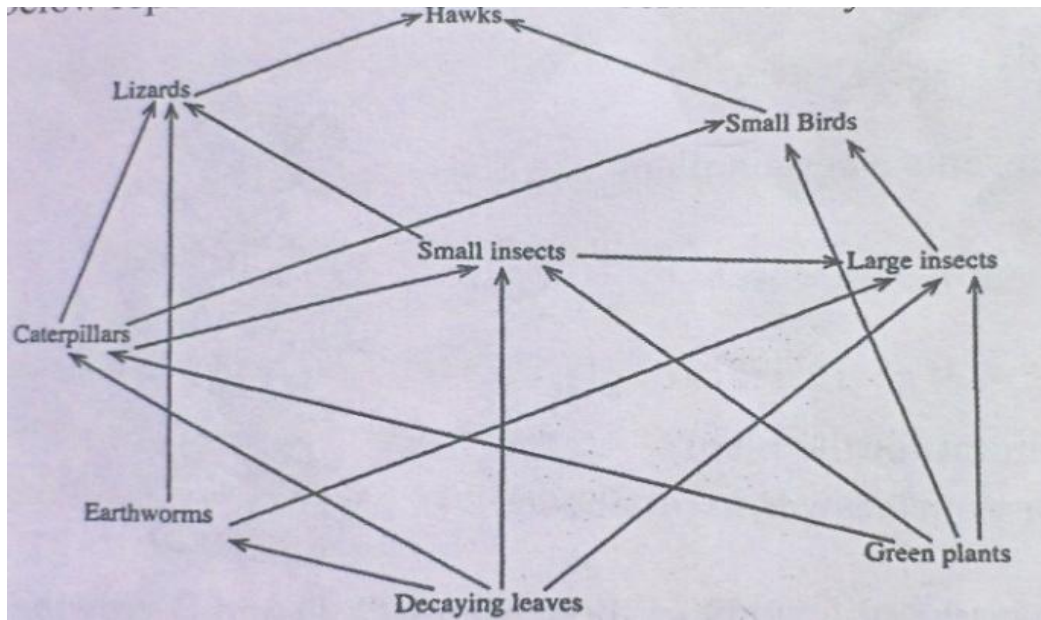

[a] Name the trophic level occupied by each of the following

[i] Caterpillars

[ii] Small insects

[b] From the food web, construct two foodchains which end with lizards as a tertiary consumer

[c][i] Which organisms have the least biomass in the ecosystem

[ii] Explain the answer in [c][i] above

38. How are leaves of mesophytes adapted to their functions?

2. REPRODUCTION IN (A) PLANTS (B) ANIMALS

1. a) Name the part of an ovule that develops into each of the following parts of a seed after fertilization
 - i) Testa
 - ii) Endosperm
- b) What is parthenocarpy?
2. State **three** roles of placenta during pregnancy.
3. Name **three main** methods through which HIV/AIDS is transmitted
4. (a) Name the processes that lead to fruit formation without fertilization
(b) Name the hormone that causes leaf, flowers and fruit abscission
(c) What is the role of ecdysone hormone in insects
5. State the roles of oviduct in female reproductive system
6. The diagram below represents a mature embryo sac. Study it carefully and answer the questions that follow:

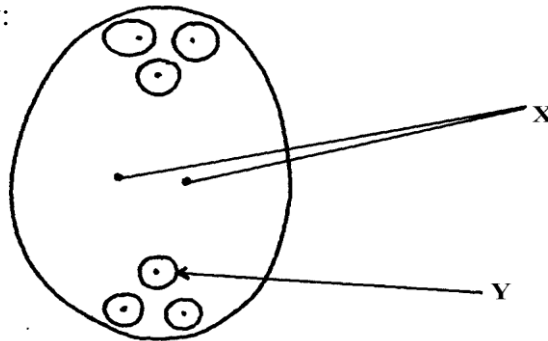

- (a) Identify structures **X** and **Y**
- (b) Why is cross pollination more advantageous to a plant species than self pollination?
7. The diagram below shows a phenomenon which occurs during cell division.

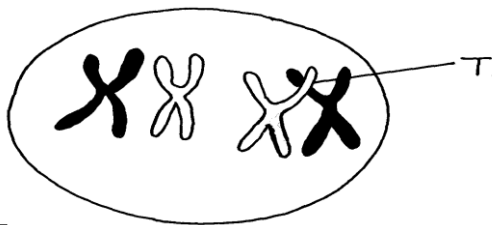

- (a) Name the part labeled **T**.
- (b) (i) State the biological importance of the part labelled **T**.
(ii) Identify the type of cell division in which this phenomenon occurs.
8. (a) When are the **two** organisms considered to belong to the same species.
(b) Explain the term **alternation of generations**.
9. (a) Explain why Larmack's Theory of evolution is not accepted by biologists today.
(b) State the significance of mutation in evolution.
10. (a) Give **two** roles of the placenta.

- (b) Explain why hormone testosterone still exerts its influence even when vas deferens have been cut.
11. Name **two** mechanisms that hinder self fertilization in flowering plants
 12. State **three** ways in which plants compensate for lack of movement
 13. (a) What do you understand by the term double fertilization?
(b) State **two** adaptations of animal dispersed fruits
 14. Name the hormone that;
(a) Stimulate the contraction of uterus during birth
(b) Stimulates the disintegration of the corpus inteuum when fertilization fails to take place
 15. State **three** ways in which flowers parent self pollination
 16. [a] Explain how the following prevent self pollination
 - [i]Protandry
 - [ii]Self sterility?
 [b]Give three advantages of cross pollination
 17. Name the type of placentation where;
 - (i) Placenta appears as one ridge on the ovary wall
 - (ii) Placenta appears at the centre of the ovary with ovules on it and the dividing walls of carpels disappear

18. The diagram below represents a mature fruit from a dicotyledonous plant, observe it and answer questions that follow

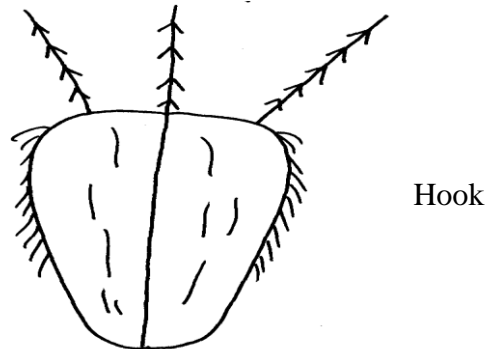

- a) To what group of fruits does the specimen belong?
- b) Suggest the possible agent of dispersal of the fruit
19. Explain why menstrual periods stop immediately after conception?
20. a) Why is sexual reproduction important in evolution of plants and animals
b) The calyx cells of a certain plant has 22 chromosomes. State the number of chromosomes present in the plant's
 - i) Endosperm
 - ii) Ovule cell

21. The diagram below shows a pollen – tube entering the ovule of a flowering plant

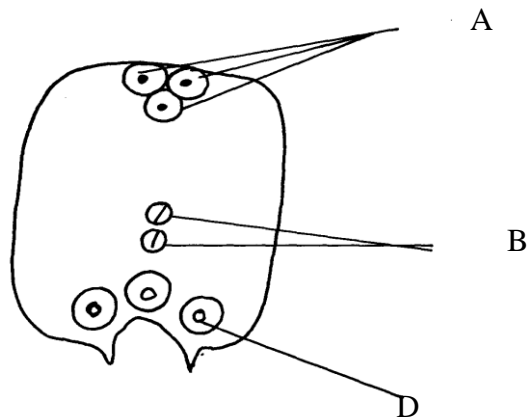

- a) Name the parts labeled **A**, **B** and **D**
 b) Name the kind of fertilization exhibited by the above flowering plant.
22. Donkey and zebra are closely related yet not of the same species. Explain
23. Name **two** factors in the environment which organisms respond to
24. What is meant by the terms:-
 a) i) Epigynous flower
 ii) Staminate flower
 b) Name the protective membranes surrounding the brain
25. The diagram below illustrate a process in a given species of organism

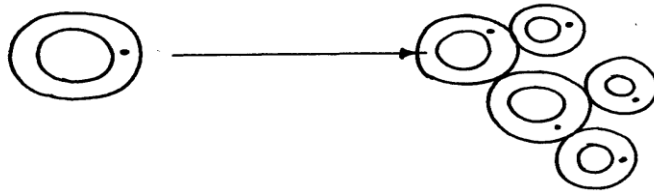

- a) Name the organism that undergoes the process above
 b) Identify the process shown to be taking place
26. State **two** ways by which HIV/AIDS is transmitted from mother to child
27. (a) State the role of centrioles during cell division
 (b) (i) Explain the role of chlorophyll in photosynthesis
 (ii) What is the **main** product of the dark stage of photosynthesis?
28. (a) At what stage of meiosis is the chiasmata formed?
 (b) (i) What is the significance of the above part in living organisms?
 (ii) State **two** importance of meiosis in living organisms?
29. (a) State **two** ways in which the male parts of a wind pollinated flower are adapted to their mode of pollination

- (b) Differentiate between monoecious and dioecious plants
30. (a) What is seed dormancy?
(b) State **two** ways in which seed dormancy can be broken
31. (a) Explain **two** importance of the adult stage in metamorphosis in insects
(b) What is the importance of the juvenile hormone in insects?
32. Describe the possible effects of discharging hot effluent from a factory into a slow flowing river
33. State **two** disadvantages of external fertilization in animals
34. State **three** roles of placenta in mammals
35. (a) The diagram below shows a stage during cell division

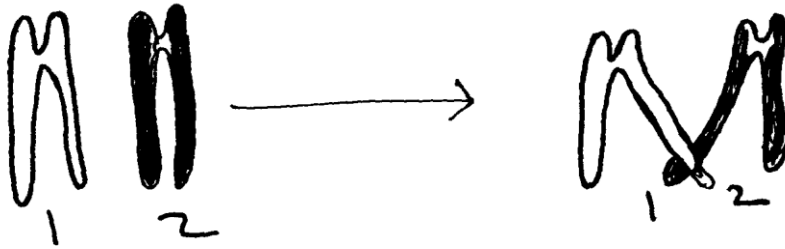

- (i) Name the stage of cell division
- (ii) Give a reason for your answer
- (b) Name **two** structures in plants where male and female gametes are produced
36. State **two** advantages of metamorphosis to the life of insects
37. List **four** differences between Mitosis and Meiosis
38. Give a reason why two species in an ecosystem cannot occupy the same niche
39. State the functions of the following hormones in the menstrual cycle :
(i) oestrogen
(ii) luteinizing hormone (L.H)

(iii) Follicle stimulating hormone (FSH)
40. [a]Name the part of the flower that develops into;
[i]Seed
[ii]Fruit
- (b) State the role played by Heterostyly in plants.
41. State the difference between the sperm cell and the ovum.

42. (a) Name the parts of the flower in which pollen grains are formed.
(b) Name **two** nuclei found in pollen grains.
43. The diagram below represents a stage in mitosis in a plant cell



- [a] Name the stage of mitosis
- [b] Give two reasons for your answer in [a] above
- [c] Name the part of the plant from which the cell used in preparation was obtained

44. Name the hormone that:
- (a) Stimulate the contraction of uterus during birth.
(b) Stimulate the disintegration of corpus luteum when fertilization fails to take place.
45. State **three** ways in which seed dormancy benefits a plant
46. (i) State **two** major structural differences between fruit and a seed
(ii) Why is it advisable to use biological control of pests?

47. State the functions of the following parts in the male reproductive system
- Spermiferous tubules
 - Sertoli cells
48. (a) Name the parts of a flower responsible for gamete formation
 (b) State **one** feature of pollen grains from a wind pollinated flower
49. Name the mechanisms that hinder self-fertilization in flowering plants
50. The eggs of birds are relatively much larger than those of mammals. Explain
51. Distinguish between the following terms:

Pollination and fertilization

52. a) Describe the various mechanisms of fruit and seed dispersal.
 b) Describe the varying events that follow a flower after fertilization.
53. Describe how fruits and seeds are suited to their mode of dispersal
54. (a) State the role of spleen in human defense mechanism
 (b) State **two** ways by which the HIV spread may be controlled through patients in hospitals
 (c) What do you understand by the word Acquired Immunity Deficiency Syndrome (AIDS)
 (d) Why is immunization against diseases encouraged by the government
 (e) State how natural active acquired immunity is attained by an individual
55. Explain how seeds and fruits are adapted to the various methods of dispersal
56. The diagram below represents female reproductive system;

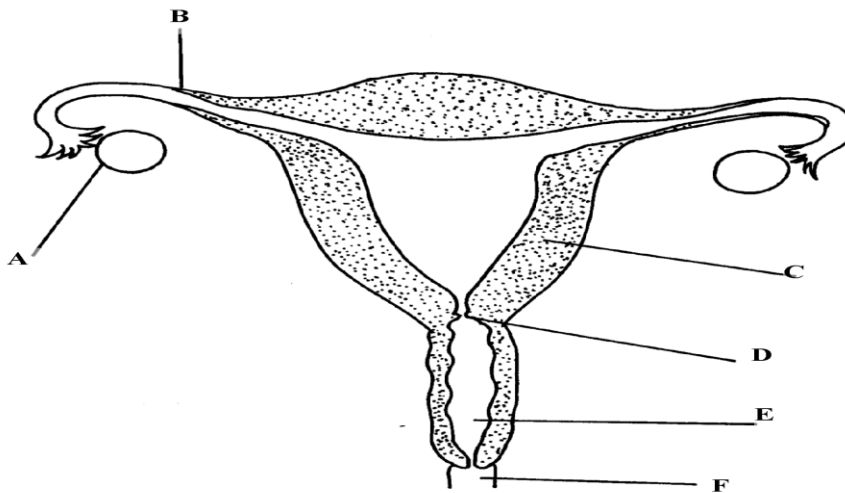

- a) Name the part labeled; A, B, C and D
- b) State **two** functions of structure A
- c) How is part C adapted to its function?
- d) Of what significance is part E to reproduction?

57. The diagram below represents a human foetus in a uterus

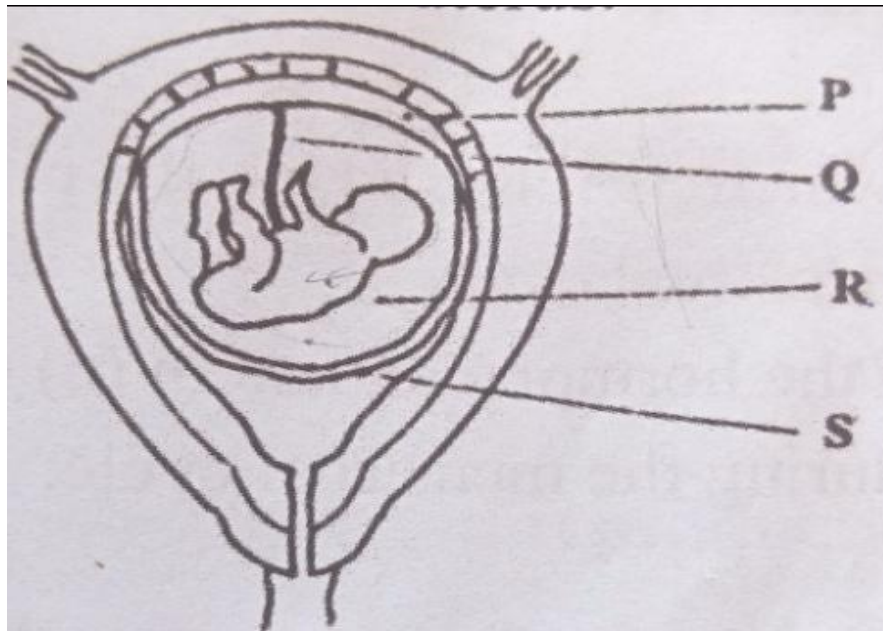

- (a) Name the part labelled **S**
 (b) (i) Name the blood vessels labelled **A** and **B**
 (ii) State the difference in composition of blood found in vessels **A** and **B**
 (c) Name **two** features that enable the structure labelled **P** carry out its function
 (d) State the role of the part labelled **R**

58. An experiment was carried out to investigate the rate of growth of pollen tube against time.

The results are shown in the table below:

Time in minutes	Growth of pollen tube in millimeters
0	0
30	4.0
60	9.8
90	15.2
120	20.0
150	21.6
180	22.4

- (a) (i) On the grid provided draw a graph of the pollen tube growth against time.
 (b) (i) At what intervals was the growth of the pollen tube measured?

- (ii) What was the length of pollen tube at; 130 minutes
- (iii) At what time was the length of the pollen tube 18mm?
- (iv) With reasons, describe the growth pattern of the pollen tube between:
- 0 to 120minutes
 - Reason
 - 120 to 180 minutes
 - Reason
- (v) State the importance of the growth of pollen tube to the plant
- (c) State the changes that take place in a flower after fertilization

3. GROWTH AND DEVELOPMENT IN PLANTS ANIMALS

1. a) Name the hormone which controls moulting in insects.
b) State the importance of moulting in insects.
2. The illustration below represents an eye defect

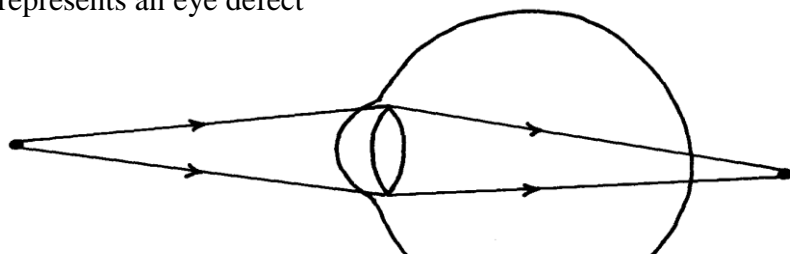

- a) Name the eye defect .
 b) Name the lenses that can be used to correct the defect.
3. (a) State **two** functions of the kidney
 (b) Name **two** substances that are not found in urine of a healthy person
 (c) Name **two** diseases that affect the kidney
4. The diagram below represents a growth pattern of arthropods.

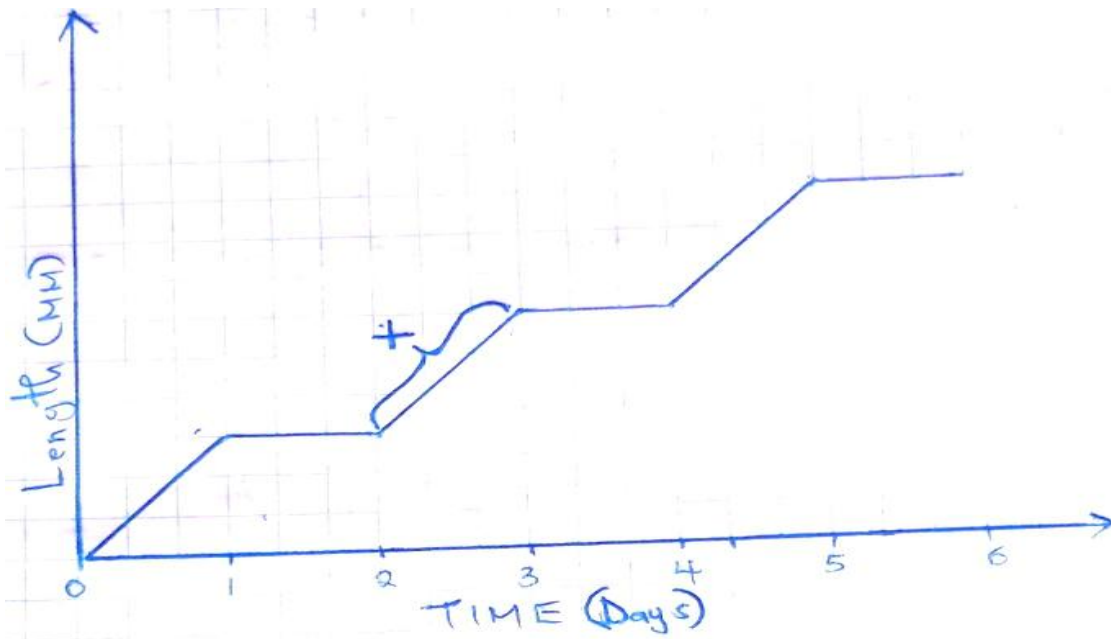

- (a) Name the type of growth pattern represented on the graph.
 (b) Identify the process represented by X.
 (c) Which hormone is responsible for process at X in 15 (b) above?
5. Distinguish between natural and acquired immunity.

6. The cells shown below were obtained from different parts of a young root tip:

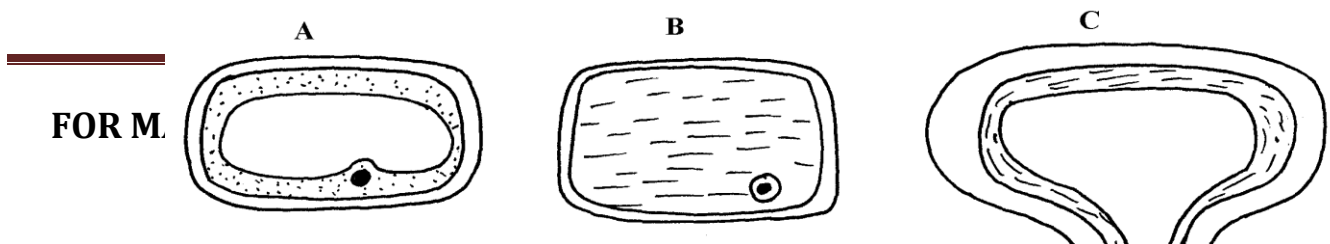

FOR M

Give the name of the zone from which each cell was obtained A, B and C

7. Differentiate between continuous and discontinuous variations
8. An experiment was set-up as shown in the diagram below:-

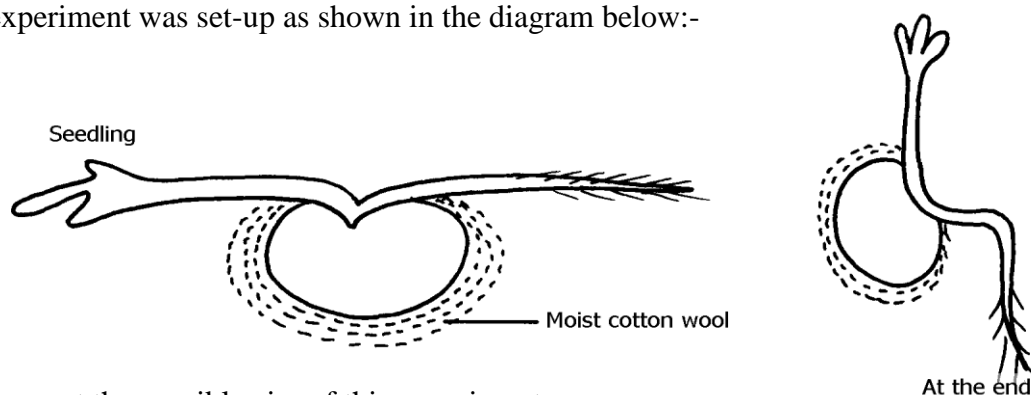

- (a) Suggest the possible aim of this experiment
- (b) Account for the observation at the end of the experiment
9. State the location of **each** of the following plant meristematic tissues:-
 - (i) Vascular cambium
 - (ii) Intercalary meristem
10. Define the following terms:
 - a) Growth
 - b) Development
11. State **two** advantages of metamorphosis in the life insects
12. State **one** disadvantage of exoskeleton in insects.
13. Distinguish between primary growth and secondary growth in a flowering plant
14. What is the role of the following to a germinating seed:
 - (i) Oxygen
 - (ii) Cotyledons
15. Give **three** applications of plant growth hormones in agriculture
16. State **two** functions of calcium in the human body

17. State the biological importance of ecdysis in arthropods
18. The diagram below represents a stage during the process of germination.

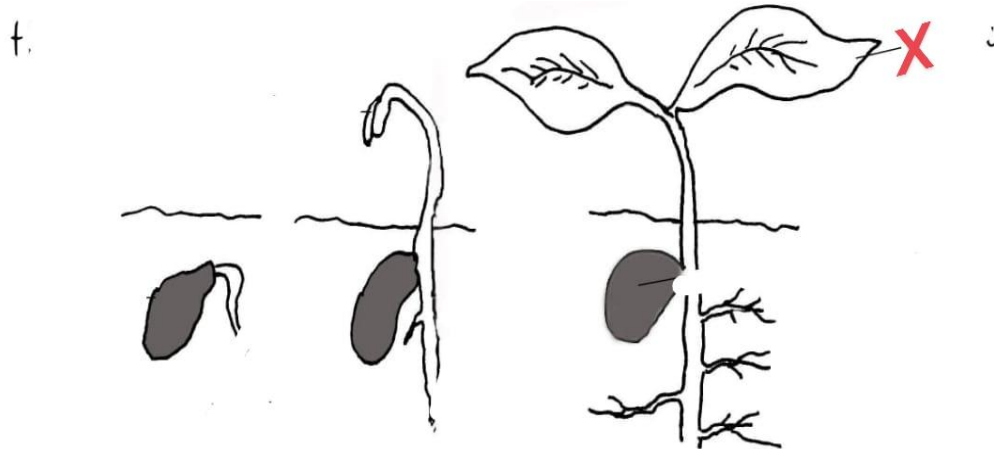

- (a) (i) Name the type of germination illustrated in the diagram
(ii) Give a reason for your answer in (a) (i) above.
- (b) Give **two** functions of the part labelled **X**
19. In an experiment young potted seedlings were placed in a dark box with unilateral light source as shown below:

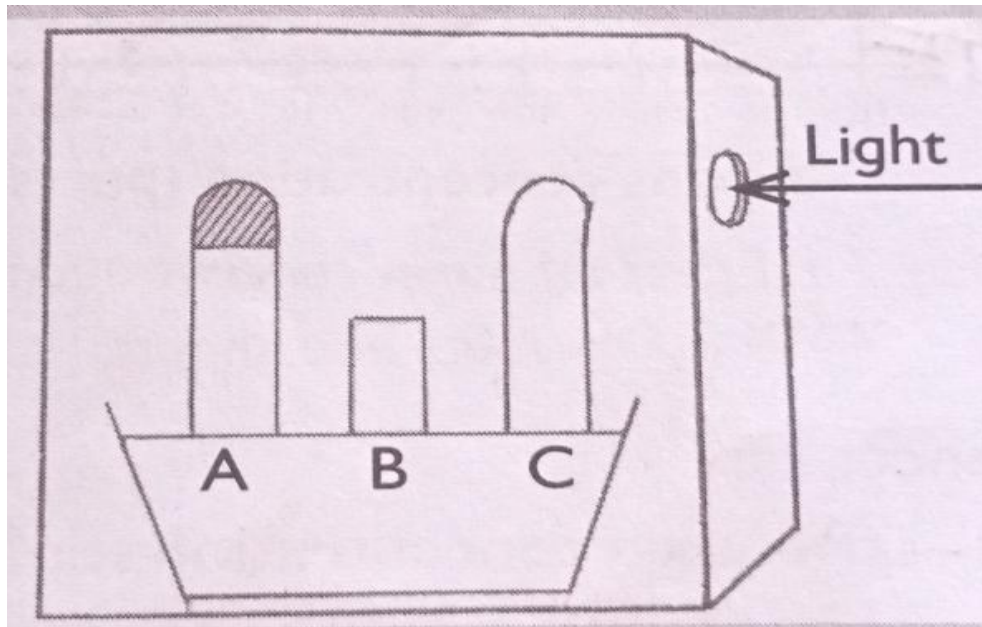

- (a) What was the aim of the experiment?
(b) State the observations made on the seedlings after 3 days
20. The graph below represents the growth of animals in a certain phylum.

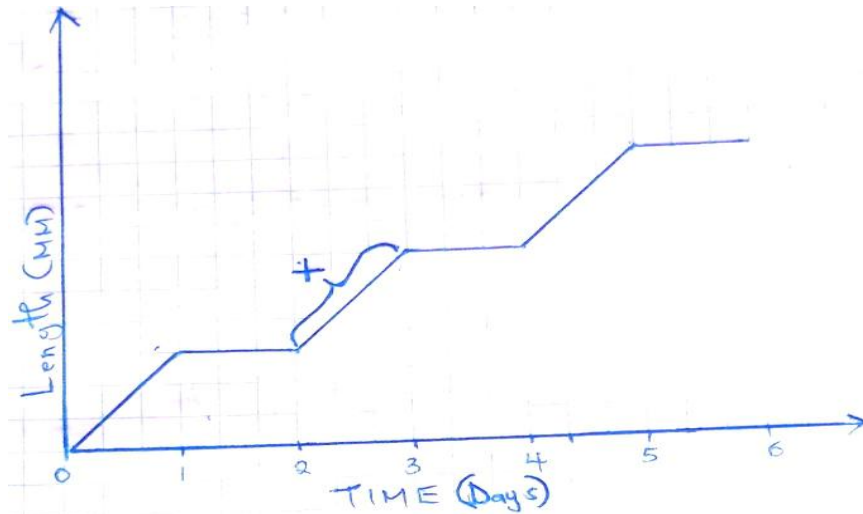

- (a) Name the type of growth pattern shown on the graph.
- (b) Identify the process represented by **x**.
- (c) Name the hormone responsible for the process in B above.
21. (a) State the role of the vascular cambium in plant growth and development.
- (b) Explain why monocotyledons plants do not undergo secondary thickening.
22. Explain how placenta is adapted to its functions
23. State the role of the following during germination:
- (a) oxygen
- (b) enzyme
24. Name the type of responses exhibited by:-
- (a) (i) Marine crabs burrowing into the sand to avoid dilution of their body fluids
- (ii) Chlamydomonas plant moving towards a region of high light intensity
- (b) (i) What type of neuron is drawn above?
- (ii) Using an arrow, show the direction of the nerve impulse
- (iii) Name the part labelled **X**
- (iv) State the function of part labelled **Y**.
- (c) Give **two** differences between reflex action and conditioned reflex action

25. The experiment set – up below was designed to investigate an aspect of germination.

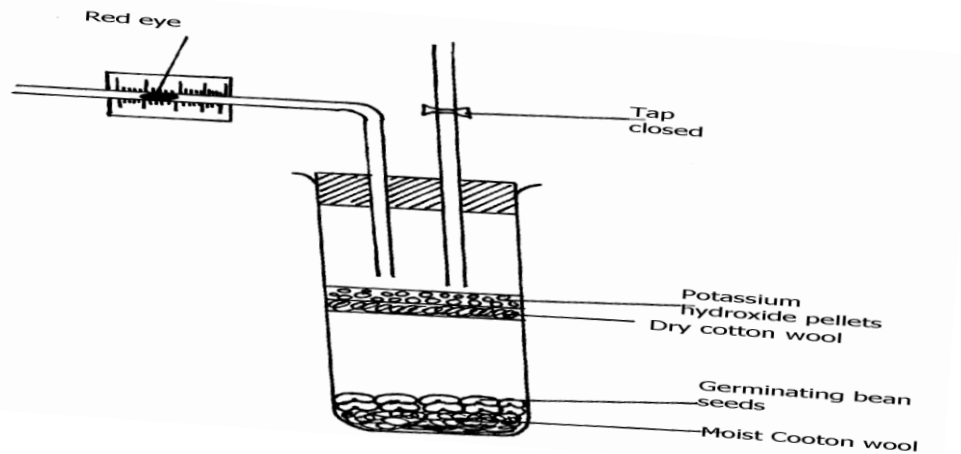

- a) Why was potassium hydroxide pellets used in this experiment?
 b) What was the role of moist cotton wool in this experiment?
 c) i) By means of an arrow, indicate on the diagram the direction in which red dye would move during the experiment.
 ii) Give reason for your answer in c(i) above.
 e) Other than the factor investigated above, state any other **one** factor necessary for germination process.
26. The following data represents the development in dry mass of germinating seedlings within 18 weeks:

Time in weeks	0	1	2	4	6	10	13	15	16	18
Dry mass in grammes	0.1	2	3.2	10	18	32	44	45	44	38

- (a) Using suitable scales plot a graph of dry mass against time
- (b) Write reference to the graph, explain the changes in dry mass between:-
 (i) Week 0 to 2
 (ii) Week 5 to 13
 (iii) Week 16 - 18
- (c) (i) What is the significance of time zero?
 (ii) What difference would be expected from the above results if the experiment started with the seeds? Give a reason for your answer
- (d) (i) Describe how you carry out the experiment to obtain dry mass in the respective

weeks

- (ii) State **one** advantage of using dry mass instead of fresh weight in estimating growth of an organism

27. The diagram below represents a set-up that was used to investigate the effect of rotation on the growth of a bean radicle. The set-up allowed the seedling to rotate slowly and continuously for seven days

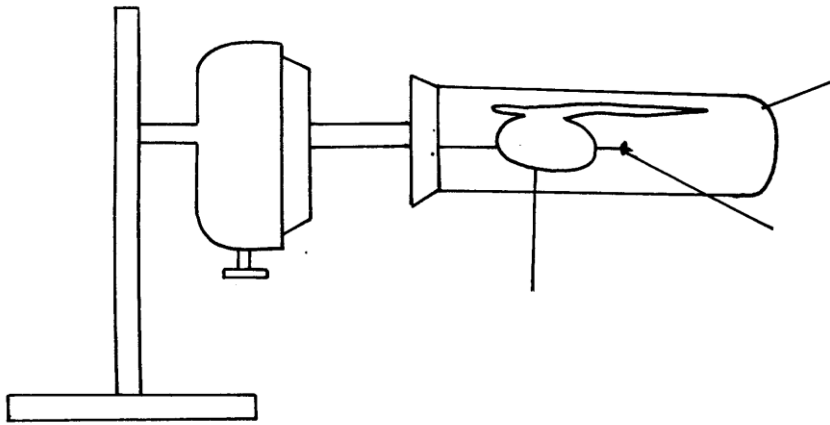

- (a) Name the piece of apparatus illustrated
- (b) (i) State the observation made on the shape of the radicle after seven days
- (ii) Explain the observation in (b) (i) above
- (c) Suggest a suitable control for this experiment
- (d) Give any **four** importance of tropism in plants
28. An experiment was carried out to determine the growth rates of variety of bamboo and a Variety of maize in two adjacent plots. The average height and average dry weight of plants from the two populations were determined over a period of twenty weeks. The data is as shown below:-
- a) On the same axes, plot a graph to show the changes in average weight of the bamboo and maize plants over time
- (b) (i) Which of the two plants had a higher productivity by the end of the experiment?
- (ii) Give a reason for your answer in (b)(i) above
- (c) Explain the following:

- (i) Between weeks 14 and 18 the average height of maize plants remained constant while the average dry weight increased
 - (ii) Dry weight was used instead of fresh weight in this experiment
 - (iii) Describe how the average height and average dry weight of plants were determined in this experiment;
 - (d) Why was it appropriate in this experiment to use both weight and height?
 - (e) Give a reason why secondary thickening does not occur in bamboo and maize plants
29. (a) What is meant by the term **fertilization** ?
- (b) (i) Name the type of cell division that produces gametes
(ii) Where does the type of cell division mentioned above occur in mammals?
- (c) What happens to the wall of the uterus;
(i) before the release of an egg ?
(ii) if no fertilization occurs?
- (b) How is the placenta adapted to its functions?
30. The relationship between seed fresh mass in the lupin *lupinus* and percentage seed germination, percentage seedling survival and seedling fresh mass is shown in the table;

Seed fresh Mass mg ⁻¹	Percentage germination	Percentage of seedlings surviving 2 leaf stage	Mean seedling fresh mass 5 weeks after germination/mg
Below 16	41.9	84.6	24.3
17-25	90.2	96.8	44.2
26-35	95.6	98.8	60.7
36-45	97.5	100.0	86.4
Above 45	100.0	100.0	106.4

- a) How was percentage germination in column two of the table calculated?
- b) Why was seed fresh mass preferred to seed dry mass to take measurements of the seed weight in the experiment
- C] i) Explain why the measurements of mean seedling fresh mass (5) weeks after germinated may not have been an accurate measurement of growth that had occurred
- ii) How could more meaningful and accurate measurement be obtained in c(i) above?
- d) With reference to the figures in the table indicate the relationship between seed fresh mass and percentage seed germination, percentage seedling survival and seedling

fresh mass

- f) Suggest an explanation why seedling produced from large seeds grow more rapidly than the seedling produced from small seeds
31. (a) Give the form in which each of the following substances are transported in mammalian blood:
- (i) Carbon (IV) oxide
 - (ii) Oxygen
- (b) Give **two** functions of pleural membrane
- (c) Explain why formation of carboxyhaemoglobin in the blood of a mammal results in death
- (d) Other than stomata, name **two** other gaseous exchange surfaces in plant
- 32 (a) State **three** characteristics of cells found just behind the root cap of a radicle
- (b) Give **two** factors inside a seed that causes seed dormancy