

# **F1 TOPICAL REVISION MATHEMATICS**

***A SERIES OF TOPICAL QUESTIONS IN FORM ONE  
MATHEMATICS***

***FOR MARKING SCHEMES  
CALL/WHATSAPP 0705525657***

**MR ISABOKE 0705525657**

## TOPIC 1

# NUMBERS

1. Mogaka and Onduso together can do a piece of work in 6 days. Mogaka, working alone, takes 5 days longer than Onduso. How many days does it take Onduso to do the same work alone?

2. (a) Evaluate

$$\underline{-8 \div 2 + 12 \times 9 - 4 \times 6}$$

$$56 \div 7 \times 2$$

(b) Simplify the expression

$$5a - 4b - 2(a - 2b + c)$$

3. Evaluate

$$\underline{28 - (-18)} - \underline{15 - (-2)(-6)}$$

$$-2 \quad 3$$

4. Three people Odawa, Mliwa and Amina contributed money to purchase a flour mill. Odawa contributed  $\frac{1}{3}$  of the total amount, Mliwa contributed  $\frac{3}{8}$  of the remaining amount and Amina contributed the rest of the money. The difference in contribution between Mliwa and Amina was Kshs 40000. Calculate the price of the flour mill.

5. Evaluate:

$$\underline{-12 \div (-3) \times 4 - (-20)}$$

$$-6 \times 6 \div 3 + (-6)$$

6. Without using logarithm tables or a calculator evaluate.

$$\frac{384.16 \times 0.0625}{96.04}$$

$$96.04$$

7. Evaluate without using mathematical table

$$1000 \quad \frac{0.0128}{200}$$

$$200$$

8. Express the numbers 1470 and 7056, each as a product of its prime factors.

Hence evaluate:  $\frac{1470^2}{7056}$

$$7056$$

Leaving the answer in prime factor form

9. Evaluate:

$$\frac{3}{4} + 1 \frac{5}{7} \div \frac{4}{7} \text{ of } 2 \frac{1}{3}$$

$$(1 \frac{3}{7} - \frac{5}{8}) \times \frac{2}{3}$$

10. Pipes A can fill an empty water tank in 3 hours while pipe B can fill the same tank in 6 hours. When the tank is full it can be emptied by pipe C in 8 hours. Pipe A and B are opened at the same time when the tank is empty. If one hour later, pipe C is also opened, find the total time taken to fill the tank.

11. In a fund- raising committee of 45 people the ratio of men to women 7:2. Find the number of women required to join the existing committee so that the ratio of men to women is changes to 5:4

12. Without using mathematical tables or calculators, evaluate

$$3 \frac{675 \times 135}{2025}$$

$$2025$$

13. All prime numbers less than ten are arranged in descending order to form a number

(a) Write down the number formed

(b) What is the total value of the second digit?

14. Evaluate without using mathematical tables or a calculator  $0.0084 \times 1.23 \times 3.5,$

$$2.87 \times 0.056$$

Expressing the answer as a fraction in its simplest form.

15. Evaluate  $\frac{1}{3}$  of  $(2\frac{3}{4} - 5\frac{1}{2}) \times 3\frac{6}{7} \div \frac{9}{4}$

16. Evaluate without using mathematical tables or the calculator

$$(.0.0625 \times 2.56)$$

$$0.25 \times 0.08 \times 0.5$$

17. Evaluate without using mathematical tables or the calculator

$$\underline{1.9 \times 0.032}$$

$$20 \times 0.0038$$

18. Evaluate  $\underline{2\frac{3}{4} \times \frac{8}{33}}$

$$3 + (5^2/5 \div 9/25)$$

19. Without using tables or calculators evaluate

$$\underline{153 \times 0.18}$$

$$0.68 \times 0.32$$

20. Without using mathematical tables, evaluate

$$1.2 \times \underline{0.0324}$$

$$0.0072$$

21. Simplify  $\frac{2}{3}$  of  $12 - (1\frac{1}{3} + 1\frac{1}{4})$

22. If  $x = 2$ , Find the value of  $x^3 - 5x^2 - 4x + 3$

23. If  $X = \frac{1}{2}$   $y = \frac{1}{4}$  and  $z = \frac{2}{3}$  Find the value of

$$\frac{x + yz}{y - xz}$$

$$y - xz$$

24. Find a and b if  $3.168 = 3^{a/b}$
25. Find the greatest common factor of  $x^8 y^2$  and  $4xy^4$ . Hence factorize completely the expression  $x^3 y^2 - 4xy^4$
26. A hot water tap can fill a bath in 5 minutes while a cold water tap can fill the same bath in 3 minutes. The drain pipe can empty the full bath in  $3\frac{3}{4}$  minutes. The two taps and the drain pipe are fully open for  $1\frac{1}{2}$  minutes after which the drain pipe are fully open for  $1\frac{1}{2}$  minutes after which the drain pipe is closed. How much will take it take to fill the bath?
27. A farmer distributed his cabbages as follows
- A certain hospital received a quarter of the total number of bags. A nearby school received half of the remainder. A green grocer received a third of what the school received. What remained were six bags more than what the green grocer received. How many bags of cabbages did the farmer have?

## TOPIC 2

### ALGEBRAIC EXPRESSIONS

1. Given that  $y = \frac{2x - z}{x + 3z}$  express  $x$  in terms of  $y$  and  $z$

2. Simplify the expression

$$\frac{x - 1}{x} - \frac{2x + 1}{3x}$$

Hence solve the equation

$$\frac{x - 1}{x} - \frac{2x + 1}{3x} = \frac{2}{3}$$

3. Factorize  $a^2 - b^2$

Hence find the exact value of  $2557^2 - 2547^2$

4. Simplify  $\frac{p^2 - 2pq + q^2}{p^3 - pq^2 + p^2q - q^3}$

$$\frac{p^2 - 2pq + q^2}{p^3 - pq^2 + p^2q - q^3}$$

5. Given that  $y = 2x - z$ , express  $x$  in terms of  $y$  and  $z$ .

Four farmers took their goats to a market. Mohammed had two more goats as Koech had 3 times as many goats as Mohammed, whereas Odupoy had 10 goats less than both Mohammed and Koech.

- (i) Write a simplified algebraic expression with one variable, representing the total number of goats.
- (ii) Three butchers bought all the goats and shared them equally. If each butcher got 17 goats, how many did odupoy sell to the butchers?

6. Factorize completely  $3x^2 - 2xy - y^2$

7. Solve the equation

$$\frac{1}{4x} = \frac{5}{6x} - 7$$

$$4x \quad 6x$$

8. Simplify

$$\frac{a}{2(a+b)} + \frac{b}{2(a-b)}$$

9. Factorize completely  $28x^2 + 3x - 1$

10. Three years ago, Juma was three times as old. As Ali in two years time, the sum of their ages will be 62. Determine their ages

11. Two pairs of trousers and three shirts cost a total of Kshs. Five such pairs of trousers and two shirt cost a total of Kshs 810. Find the price of a pair of trouser and shirt.



### TOPIC 3

#### RATES, RATIO PERCENTAGE AND PROPORTION

1. Akinyi bought maize and beans from a wholesaler. She then mixed the maize and beans in the ratio 4:3 she bought the maize at Kshs 21 per kg and the beans 42 per kg. If she was to make a profit of 30%. What should be the selling price of 1 kg of the mixture?
2. Water flows from a tap at the rate of  $27 \text{ cm}^3$  per second into a rectangular container of length 60 cm, breadth 30 cm and height 40 cm. If at 6.00 PM the container was half full, what will be the height of water at 6.04 pm?
3. Two businessmen jointly bought a minibus which could ferry 25 paying passengers when full. The fare between two towns A and B was Kshs 80 per passenger for one way. The minibus made three round trips between the two towns daily. The cost of fuel was Kshs 1500 per day. The driver and the conductor were paid daily allowances of Kshs 200 and Kshs 150 respectively. A further Kshs 4000 per day was set aside for maintenance, insurance and loan repayment.
  - (a)
    - (i) How much money was collected from the passengers that day?
    - (ii) How much was the net profit?
  - (b) On another day, the minibus was 80% full on the average for the three round trips, how much did each businessman get if the day's profit was shared in the ratio 2:3?

4. Wainaina has two dairy farms, A and B. Farm A produces milk with  $3\frac{1}{4}$  percent fat and farm B produces milk with  $4\frac{1}{4}$  percent fat.
- (a) Determine
- (i) The total mass of milk fat in 50 kg of milk from farm A and 30 kg of milk from farm B
- (ii) The percentage of fat in a mixture of 50kg of milk A and 30kg of milk from B
- (b) The range of values of mass of milk from farm B that must be used in a 50kg mixture so that the mixture may have at least 4 percent fat.
5. In the year 2001, the price of a sofa set in a shop was Kshs 12,000
- (a) Calculate the amount of money received from the sales of 240 sofa sets that year.
- (b) (i) In the year 2002 the price of each sofa set increased by 25% while the number of sets sold decreased by 10%. Calculate the percentage increase in the amount received from the sales
- (ii) If the end of year 2002, the price of each sofa set changed in the ratio 16: 15, calculate the price of each sofa set in the year 2003.
- (c) The number of sofa sets sold in the year 2003 was P% less than the number sold in the year 2001.
- Calculate the value of P, given that the amounts received from sales if the two years were equal.

6. A solution whose volume is 80 litres is made up of 40% of water and 60% of alcohol. When  $x$  litres of water is added, the percentage of alcohol drops to 40%.
- (a) Find the value of  $x$
  - (b) Thirty litres of water is added to the new solution. Calculate the percentage of alcohol in the resulting solution
  - (c) If 5 litres of the solution in (b) above is added to 2 litres of the original solution, calculate in the simplest form, the ratio of water to that of alcohol in the resulting solution.
7. Three business partners, Asha, Nangila and Cherop contributed Kshs 60,000, Kshs 85,000 and Kshs 105, 000 respectively. They agreed to put 25% of the profit back into business each year. They also agreed to put aside 40% of the remaining profit to cater for taxes and insurance. The rest of the profit would then be shared among the partners in the ratio of their contributions. At the end of the first year, the business realized a gross profit of Kshs 225, 000.
- (a) Calculate the amount of money Cherop received more than Asha at the end of the first year.
  - (b) Nangila further invested Kshs 25,000 into the business at the beginning of the second year. Given that the gross profit at the end of the second year increased in the ratio 10:9, calculate Nangila's share of the profit at the end of the second year.

8. Kipketer can cultivate a piece of land in 7 hrs while Wanjiku can do the same work in 5 hours. Find the time they would take to cultivate the piece of land when working together.
9. Mogaka and Ondiso working together can do a piece of work in 6 days. Mogaka working alone, takes 5 days longer than Onduso. How many days does it take Onduso to do the work alone.
10. A certain amount of money was shared among 3 children in the ratio 7:5:3 the largest share was Kshs 91. Find the
- (a) Total amount of money
  - (b) Difference in the money received as the largest share and the smallest share.

**TOPIC 4**  
**MEASUREMENT**

1. The figure below shows a portable kennel

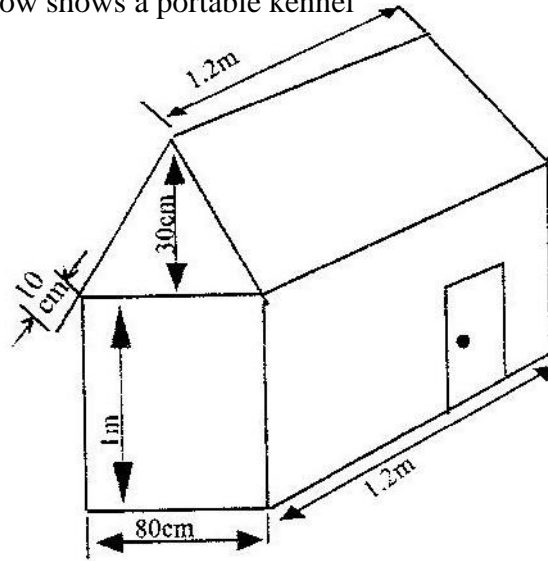

- (a) Calculate
- (i) The total surface area of the walls and the floor (include the door as part of the wall).
  - (ii) The total surface area of the roof
- (b) The cost of roofing is Kshs 300 per square metre and that of making walls and floor Kshs 350 per square metre. Find the cost of making the kennel.

2. The enclosed region shown in the figure below represents a ranch draw to scale.

The actual area of the ranch is 1075 hectares

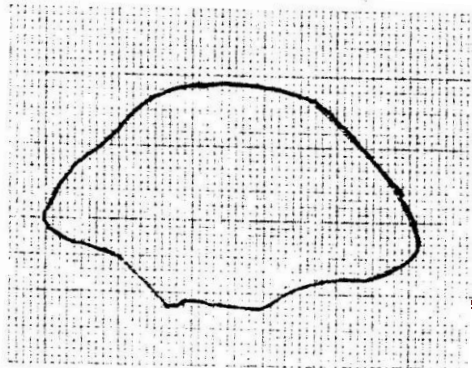

- (a) Estimate the area of the enclosed region in square centimeters
- (b) Calculate the linear scale used
3. The figure below shows an octagon obtained by cutting off four congruent triangles from a rectangle measuring 19.5 by 16.5 cm

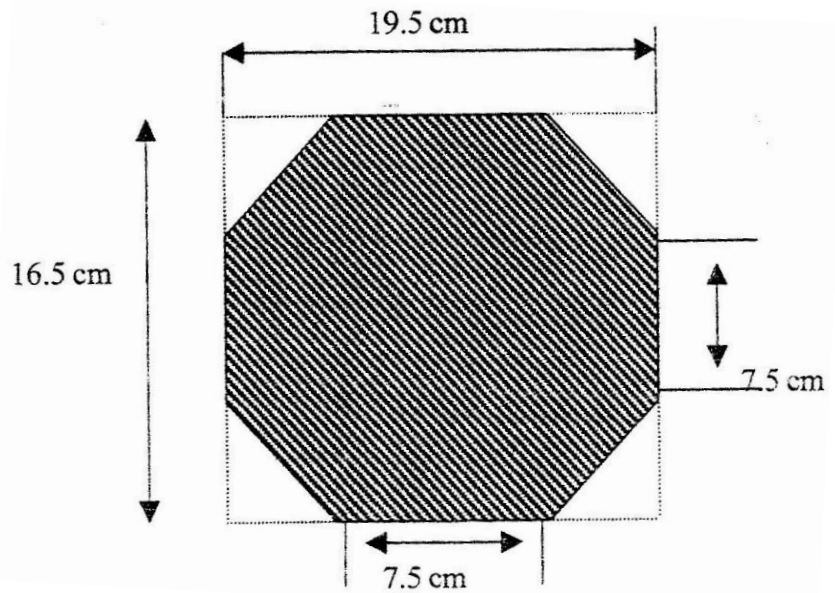

Calculate the area of the octagon

4. The length of a hollow cylindrical pipe is 6 metres. Its external diameter is 11 cm and has a thickness of 1 cm. Calculate the, volume in  $\text{cm}^3$  of the materials used to make the pipe. Take  $\pi$  as 3.142.
5. The area of rhombus is  $60 \text{ cm}^2$ . Given that one of its diagonals is 15 cm long, calculate the perimeter of the rhombus.
6. A cylindrical piece of wood of radius 4.2 cm and length 150 cm is cut lengthwise into two equal pieces.

Calculate the surface area of one piece

(Take  $\pi$  as  $\frac{22}{7}$ )

7. The diagram below (not drawn to scale) represents the cross section of a solid prism of height 8.0 cm

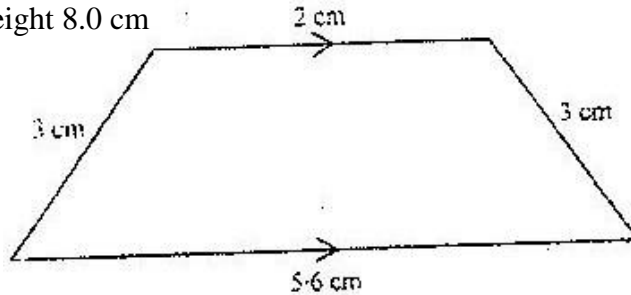

- (a) Calculate the volume of the prism
- (b) Given that the density of the prism is  $5.75 \text{ g/cm}^3$ , calculate its mass in grams
- (c) A second prism is similar to the first one but is made of different material. The volume of the second prism is  $246.24 \text{ cm}^3$
- (i) Calculate the area of cross section of the second prism
- (ii) Given the ratio of the mass of the first prism to the second is 2:5, find the density of the second prism.
8. A square brass plate is 2 mm thick and has a mass of 1.05 kg. The density of the brass is  $8.4 \text{ g/cm}^3$ . Calculate the length of the plate in centimeters.
9. Two cylindrical containers are similar. The larger one has internal cross-section area of  $45 \text{ cm}^2$  and can hold 0.95 litres of liquid when full. The smaller container has internal cross-section area of  $20 \text{ cm}^2$
- (a) Calculate the capacity of the smaller container

- (b) The larger container is filled with juice to a height of 13 cm. Juice is then drawn from it and emptied into the smaller container until the depth of the juice in both containers are equal. Calculate the depth of juice in each container.
- (c) One fifth of the juice in the larger container in part (b) above is further drawn and emptied into the smaller container. Find the differences in the depths of the juice in the two containers.

10. Pieces of soap are packed in a cuboid container measuring 36 cm by 24 cm by 18 cm. Each piece of soap is similar to the container. If the linear scale factor between the container and the soap is  $\frac{1}{6}$ . Find the volume of each piece of soap.

11. A cylindrical water tank is of diameter 7 metres and height 2.8 metres

- (a) Find the capacity of the water tank in litres
- (b) Six members of family use 15 litres each per day. Each day 80 litres are used for cooking and washing. And a further 60 litres are wasted.  
Find the number of complete days a full tank would last the family
- (c) Two members of the family were absent for 90 days. During the 90 days, wastage was reduced by 20% but cooking and washing remained the same.

Calculate the number of days a full tank would now last the family



12. A company is to construct parking bay whose area is  $135\text{m}^2$ . It is to be covered with a concrete slab of uniform thickness of  $0.15\text{m}$ . To make the slab cement, ballast and sand are to be mixed so that their masses are in the ratio  $1:4:4$  the mass of  $1\text{m}^3$  of dry slab is  $2,500\text{ kg}$ .

- (a) Calculate
- (i) The volume of the slab
  - (ii) The mass of dry slab
  - (iii) The mass of cement to be used
- (b) If one bag of cement is  $50\text{kg}$ . Find the number of bags to be purchased
- (c) If a lorry carries  $7$  tonnes of sand, calculate the number of lorries of sand to be purchased

13. An Artisan has  $63\text{ kg}$  of metal of density  $7000\text{ kg/m}^3$ . He intends to use to make a rectangular pipe with external dimensions  $12\text{ cm}$  by  $15\text{ cm}$  and internal dimensions  $10\text{cm}$  by  $12\text{ cm}$ . Calculate the length of the pipe in metres.

14. The figure below represents hollow cylinder. The internal and external radii are estimated to be  $6\text{ cm}$  and  $8\text{ cm}$  respectively, to the nearest whole number. The height of the cylinder is exactly  $14\text{ cm}$ .

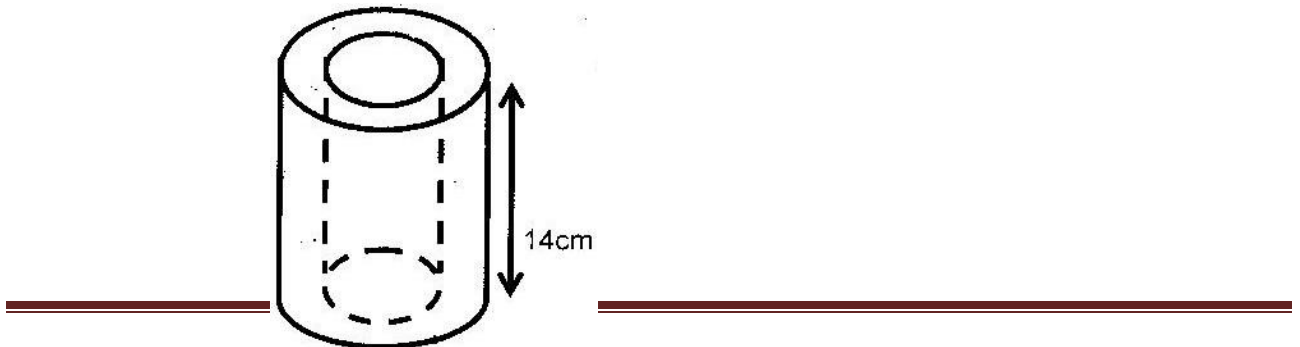

**FOR MARKING SCHEMES CALL/WHATSAPP  
0705525657/0770195807**

- (a) Determine the exact values for internal and external radii which will give maximum volume of the material used.
- (b) Calculate the maximum possible volume of the material used. Take the value of  $\pi$  to be  $\frac{22}{7}$
15. Calculate the volume of a prism whose length is 25 cm and whose length is 25 cm and whose cross – section is an equilateral triangle of side 3 cm
16. The figure below shows an octagon obtained by cutting off four congruent triangles from a rectangle measuring 19.5 by 16.5 cm

Calculate the area of the octagon

17. The figure below represents a kite ABCD,  $AB = AD = 15$  cm. the diagonals BD and AC intersect at O,  $AC = 30$  cm and  $AO = 12$  cm.

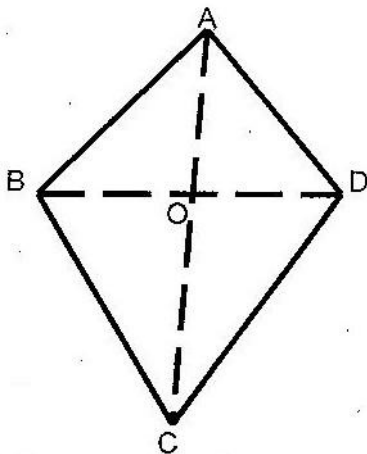

Find the area of the kite

18. The figure below is a map of a forest drawn on a grid of 1 cm squares

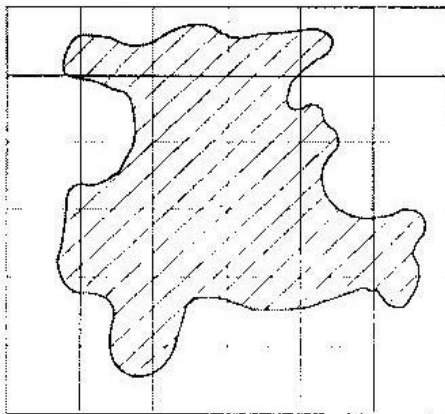

---

CALL/WHATSAPP

0195807

0705525057/0770195807

- (a) Estimate the area of the map in square centimeters if the scale of the map is 1: 50, 000; estimate the area of the forest in hectares.

**TOPIC 5:**

**LINEAR EQUATIONS**

1. A cloth dealer sold 3 shirts and 2 trousers for Kshs 840 and 4 shirts and 5 trousers for Kshs 1680 find the cost of 1 shirt and the cost of 1 trouser
2. Solve the simultaneous equations  
$$2x - y = 3$$
$$x^2 - xy = -4$$
3. The cost of 5 skirts and blouses is Kshs 1750. Mueni bought three of the skirts and one of the blouses for Kshs 850. Find the cost of each item.
4. Akinyi bought three cups and four spoons for Kshs 324. Wanjiru bought five cups and Fatuma bought two spoons of the same type as those bought by Akinyi, Wanjiku paid Kshs 228 more than Fatuma. Find the price of each cup and each spoon.
5. Mary has 21 coins whose total value is Kshs. 72. There are twice as many five shillings coins as there are ten shilling coins. The rest one shillings coins. Find the number of ten shillings coins that Mary has. ( 4 mks)

6. The mass of 6 similar art books and 4 similar biology books is 7.2 kg. The mass of 2 such art books and 3 such biology books is 3.4 kg. Find the mass of one art book and the mass of one biology book
7. Karani bought 4 pencils and 6 biros – pens for Kshs 66 and Tachora bought 2 pencils and 5 biro pens for Kshs 51.
- (a) Find the price of each item
- (b) Musoma spent Kshs. 228 to buy the same type of pencils and biro – pens if the number of biro pens he bought were 4 more than the number of pencils, find the number of pencils bought.
8. Solve the simultaneous equations below
- $$2x - 3y = 5$$
- $$-x + 2y = -3$$
9. The length of a room is 4 metres longer than its width. Find the length of the room if its area is  $32\text{m}^2$
10. Hadija and Kagendo bought the same types of pens and exercise books from the same types of pens and exercise books from the same shop. Hadija bought 2 pens and 3 exercise books for Kshs 78. Kagendo bought 3 pens and 4 exercise books for Kshs 108.
- Calculate the cost of each item
11. In fourteen years time, a mother will be twice as old as her son. Four years ago, the sum of their ages was 30 years. Find how old the mother was, when the son was born.

12. Three years ago Juma was three times as old as Ali. In two years time the sum of their ages will be 62. Determine their ages.
13. Two pairs of trousers and three shirts costs a total of Kshs 390. Five such pairs of trousers and two shirts cost a total of Kshs 810. Find the price of a pair of trousers and a shirt.
14. A shopkeeper sells two- types of pangas type x and type y. Twelve x pangas and five type y pangas cost Kshs 1260, while nine type x pangas and fifteen type y pangas cost 1620. Mugala bought eighteen type y pangas. How much did he pay for them?

## TOPIC 6:

### COMMERCIAL ARITHMETICS

1. The cash prize of a television set is Kshs 25000. A customer paid a deposit of Kshs 3750. He repaid the amount owing in 24 equal monthly installments. If he was charged simple interest at the rate of 40% p.a how much was each installment?
2. Mr Ngeny borrowed Kshs 560,000 from a bank to buy a piece of land. He was required to repay the loan with simple interest for a period of 48 months. The repayment amounted to Kshs 21,000 per month.  
Calculate
  - (a) The interest paid to the bank
  - (b) The rate per annum of the simple interest
3. A car dealer charges 5% commission for selling a car. He received a commission of Kshs 17,500 for selling car. How much money did the owner receive from the sale of his car?
4. A company saleslady sold goods worth Kshs 240,000 from this sale she earned a commission of Kshs 4,000
  - (a) Calculate the rate of commission
  - (b) If she sold good whose total marked price was Kshs 360,000 and allowed a discount of 2% calculate the amount of commission she received.
5. A business woman bought two bags of maize at the same price per bag. She discovered that one bag was of high quality and the other of low quality. On

the high quality bag she made a profit by selling at Kshs 1,040, whereas on the low quality bag she made a loss by selling at Kshs 880. If the profit was three times the loss, calculate the buying price per bag.

6. A salesman gets a commission of 2.4 % on sales up to Kshs 100,000. He gets an additional commission of 1.5% on sales above this. Calculate the commission he gets on sales worth Kshs 280,000.
7. Three people Koris, Wangare and Hassan contributed money to start a business. Korir contributed a quarter of the total amount and Wangare two fifths of the remainder.  
Hassan's contribution was one and a half times that of Koris. They borrowed the rest of the money from the bank which was Kshs 60,000 less than Hassan's contribution. Find the total amount required to start the business.
8. A Kenyan tourist left Germany for Kenya through Switzerland. While in Switzerland he bought a watch worth 52 deutsche Marks. Find the value of the watch in:

- (a) Swiss Francs.
- (b) Kenya Shillings

Use the exchange rates below:

1 Swiss Franc = 1.28 Deutsche Marks.

1 Swiss Franc = 45.21 Kenya Shillings

9. A salesman earns a basic salary of Kshs. 9000 per month  
In addition he is also paid a commission of 5% for sales above Kshs 15000

---

**FOR MARKING SCHEMES CALL/WHATSAPP  
0705525657/0770195807**



In a certain month he sold goods worth Kshs. 120, 000 at a discount of  $2\frac{1}{2}$  % . Calculate his total earnings that month

10. In this question, mathematical table should not be used

A Kenyan bank buys and sells foreign currencies as shown below

	Buying (In Kenya shillings)	Selling In Kenya Shillings
1 Hong Kong dollar	9.74	9.77
1 South African rand	12.03	12.11

A tourists arrived in Kenya with 105 000 Hong Kong dollars and changed the whole amount to Kenyan shillings. While in Kenya, she pent Kshs 403 897 and changed the balance to South African rand before leaving for South Africa. Calculate the amount, in South African rand that she received.

11. A Kenyan businessman bought goods from Japan worth 2, 950 000 Japanese yen. On arrival in Kenya custom duty of 20% was charged on the value of the goods.

If the exchange rates were as follows

1 US dollar = 118 Japanese Yen

1 US dollar = 76 Kenya shillings

Calculate the duty paid in Kenya shillings

12. Two businessmen jointly bought a minibus which could ferry 25 paying passengers when full. The fare between two towns A and B was Kshs. 80 per

passenger for one way. The minibus made three round trips between the two towns daily. The cost of fuel was Kshs 1500 per day. The driver and the conductor were paid daily allowances of Kshs 200 and Kshs 150 respectively. A further Kshs 4000 per day was set aside for maintenance.

- (a) One day the minibus was full on every trip.
- (i) How much money was collected from the passengers that day?
  - (ii) How much was the net profit?
- (b) On another day, the minibus was 80% on the average for the three round trips. How much did each business get if the days profit was shared in the ratio 2:3?

13. A traveler had sterling pounds 918 with which he bought Kenya shillings at the rate of Kshs 84 per sterling pound. He did not spend the money as intended. Later, he used the Kenyan shillings to buy sterling pound at the rate of Kshs. 85 per sterling pound. Calculate the amount of money in sterling pounds lost in the whole transaction.

14. A commercial bank buys and sells Japanese Yen in Kenya shillings at the rates shown below

Buying     0.5024

Selling    0.5446

A Japanese tourist at the end of his tour of Kenya was left with Kshs. 30000 which he converted to Japanese Yen through the commercial bank. How many Japanese Yen did he get?

15. In the month of January, an insurance salesman earned Kshs. 6750 which was commission of 4.5% of the premiums paid to the company.

(a) Calculate the premium paid to the company.

(b) In February the rate of commission was reduced by  $66\frac{2}{3}\%$  and the premiums reduced by 10% calculate the amount earned by the salesman in the month of February

16. Akinyi, Bundi, Cura and Diba invested some money in a business in the ratio of 7:9:10:14 respectively. The business realized a profit of Kshs 46800. They shared 12% of the profit equally and the remainder in the ratio of their contributions. Calculate the total amount of money received by Diba.

17. A telephone bill includes Kshs 4320 for a local calls Kshs 3260 for trunk calls and rental charge Kshs 2080. A value added tax (V.A.T) is then charged at 15%, Find the total bill.

18. During a certain period. The exchange rates were as follows

1 sterling pound = Kshs 102.0

1 sterling pound = 1.7 us dollar

1 U.S dollar = Kshs 60.6

A school management intended to import textbooks worth Kshs 500,000 from UK. It changed the money to sterling pounds. Later the management found out that the books the sterling pounds to dollars. Unfortunately a financial crisis arose and the money had to be converted to Kenya shillings. Calculate the total amount of money the management ended up with.

19. A fruiterer bought 144 pineapples at Kshs 100 for every six pineapples. She sold some of them at Kshs 72 for every three and the rest at Kshs 60 for every two.

If she made a 65% profit, calculate the number of pineapples sold at Kshs 72 for every three.

**TOPIC 7:**  
**GEOMETRY**

1. A point B is on a bearing of  $080^{\circ}$  from a port A and at a distance of 95 km. A submarine is stationed at a port D, which is on a bearing of  $200^{\circ}$  from AM and a distance of 124 km from B.
- A ship leaves B and moves directly southwards to an island P, which is on a bearing of  $140^{\circ}$  from A. The submarine at D on realizing that the ship was heading for the island P, decides to head straight for the island to intercept the ship
- Using a scale of 1 cm to represent 10 km, make a scale drawing showing the relative positions of A, B, D, P.

Hence find

- (i) The distance from A to D
  - (ii) The bearing of the submarine from the ship was setting off from B
  - (iii) The bearing of the island P from D
  - (iv) The distance the submarine had to cover to reach the island P
2. Four towns R, T, K and G are such that T is 84 km directly to the north R, and K is on a bearing of  $295^{\circ}$  from R at a distance of 60 km. G is on a bearing of  $340^{\circ}$  from K and a distance of 30 km. Using a scale of 1 cm to represent 10 km, make an accurate scale drawing to show the relative positions of the town.

Find

- (a) The distance and the bearing of T from K

- (b) The distance and the bearing G from T
- (c) The bearing of R from G

3. Two aeroplanes, S and T leave airports A at the same time. S flies on a bearing of  $060^\circ$  at  $750 \text{ km/h}$  while T flies on a bearing of  $210^\circ$  at  $900 \text{ km/h}$ .

(a) Using a suitable scale, draw a diagram to show the positions of the aeroplane after two hours.

(b) Use your diagram to determine

(i) The actual distance between the two aeroplanes

(ii) The bearing of T from S

(iii) The bearing of S from T

4. A point A is directly below a window. Another point B is  $15 \text{ m}$  from A and at the same horizontal level. From B angle of elevation of the top of the bottom of the window is  $30^\circ$  and the angle of elevation of the top of the window is  $35^\circ$ .

Calculate the vertical distance.

(a) From A to the bottom of the window

(b) From the bottom to top of the window

5. Find by calculation the sum of all the interior angles in the figure ABCDEFGHI

below

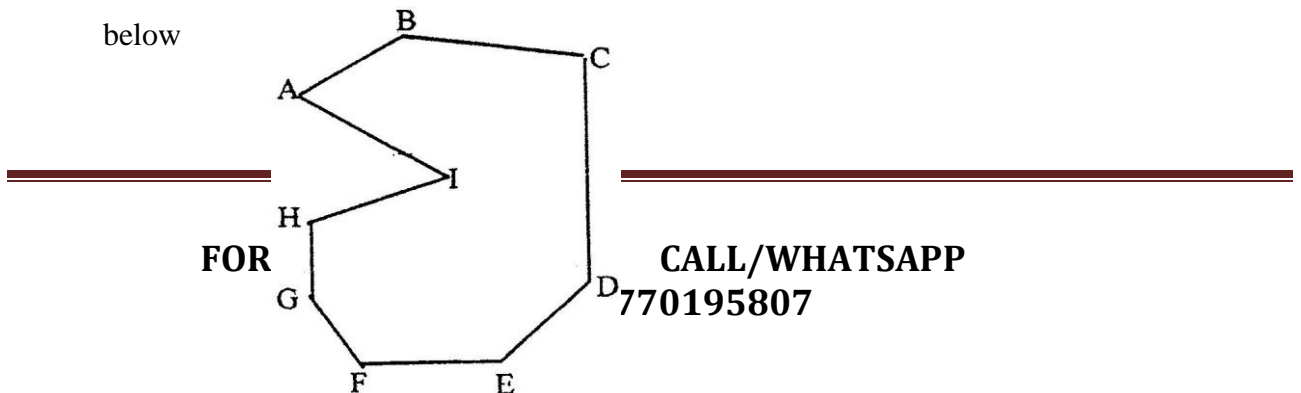

6. Shopping centers X, Y and Z are such that Y is 12 km south of X and Z is 15 km from X. Z is on a bearing of  $330^{\circ}$  from Y. Find the bearing of Z from X.
7. An electric pylon is 30m high. A point S on the top of the pylon is vertically above another point R on the ground. Points A and B are on the same horizontal ground as R. Point A due south of the pylon and the angle of elevation of S from A is  $26^{\circ}$ . Point B is due west of the pylon and the angle of elevation of S from B is  $32^{\circ}$
- Find the
- Distance from A and B
  - Bearing of B from A
8. The figure below is a polygon in which  $AB = CD = FA = 12\text{cm}$   $BC = EF = 4\text{cm}$  and  $\angle BAF = \angle CDE = 120^{\circ}$ . AD is a line of symmetry.

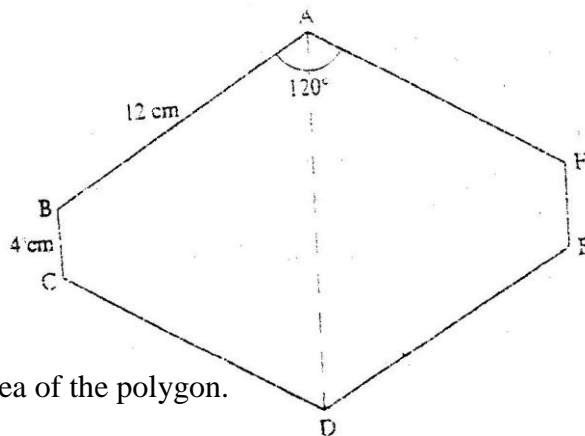

Find the area of the polygon.

9. The figure below shows a triangle ABC.

---

**FORM**

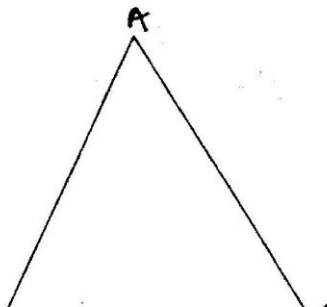

---

**ALL/WHATSAPP  
195807**

- a) Using a ruler and a pair of compasses, determine a point D on the line BC such that  $BD:DC = 1:2$ .
- b) Find the area of triangle ABD, given that  $AB = AC$ .
10. A boat at point X is 200 m to the south of point Y. The boat sails X to another point Z. Point Z is 200m on a bearing of  $310^\circ$  from X, Y and Z are on the same horizontal plane.
- (a) Calculate the bearing and the distance of Z from Y
- (b) W is the point on the path of the boat nearest to Y.  
Calculate the distance WY
- (c) A vertical tower stands at point Y. The angle of point X from the top of the tower is  $6^\circ$  calculate the angle of elevation of the top of the tower from W.
11. The figure below shows a quadrilateral ABCD in which  $AB = 8$  cm,  $DC = 12$  cm,  $\angle BAD = 45^\circ$ ,  $\angle CBD = 90^\circ$  and  $\angle BCD = 30^\circ$ .

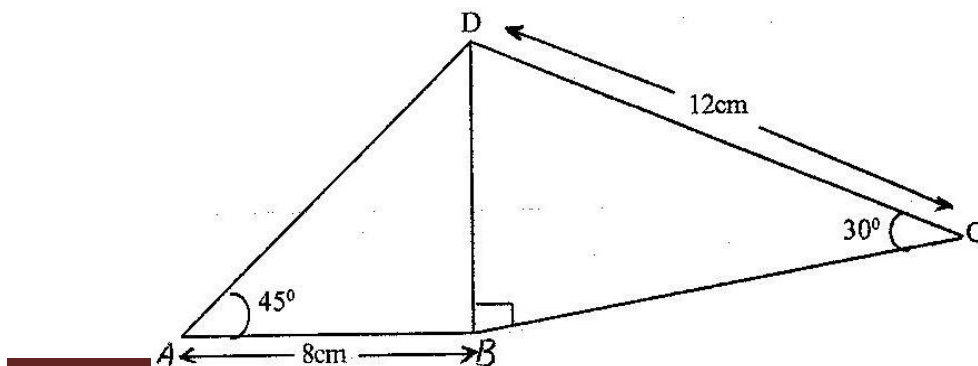

**FOR MARKING SCHEMES CALL/WHATSAPP  
0705525657/0770195807**



Find:

- (a) The length of BD
- (b) The size of the angle A D B

12. In the figure below, ABCDE is a regular pentagon and ABF is an equilateral triangle

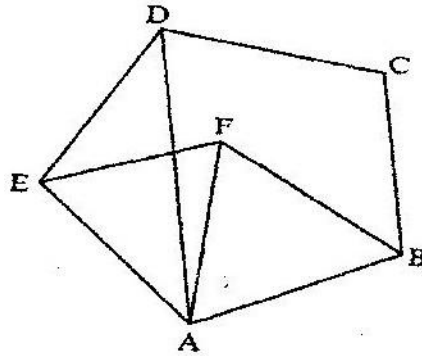

Find the size of

- a)  $\angle ADE$
- b)  $\angle AEF$
- c)  $\angle DAF$

13. In this question use a pair of compasses and a ruler only

(a) construct triangle ABC such that  $AB = 6 \text{ cm}$ ,  $BC = 8 \text{ cm}$  and  $\angle ABC 135^\circ$

(2 marks)

(b) Construct the height of triangle ABC in a) above taking BC as the base

(1 mark)

14. The size of an interior angle of a regular polygon is  $3x^\circ$  while its exterior angle is  $(x - 20)^\circ$ . Find the number of sides of the polygon
15. Points L and M are equidistant from another point K. The bearing of L from K is  $330^\circ$ . The bearing of M from K is  $220^\circ$ .  
Calculate the bearing of M from L
16. Four points B, C, Q and D lie on the same plane point B is the 42 km due south-west of town Q. Point C is 50 km on a bearing of  $560^\circ$  from Q. Point D is equidistant from B, Q and C.
- (a) Using the scale 1 cm represents 10 km, construct a diagram showing the position of B, C, Q and D
- (b) Determine the
- (i) Distance between B and C
- (ii) Bearing D from B
17. Two aeroplanes P and Q, leave an airport at the same time flies on a bearing of  $240^\circ$  at 900km/hr while Q flies due East at 750 km/hr
- (a) Using a scale of 1v cm drawing to show the positions of the aeroplanes after 40 minutes.
- (b) Use the scale drawing to find the distance between the two aeroplane after 40 minutes
- (c) Determine the bearing of
- (i) P from Q ans  $254^\circ$

(ii) Q from P ans  $74^{\circ}$

18. A port B is on a bearing of  $080^{\circ}$  from a port A and at a distance of 95 km. A submarine is stationed at port D which is on a bearing of  $200^{\circ}$  from A, and at a distance of 124 km from B.

A ship leaves B and moves directly southwards to an island P, which is on a bearing of  $140^{\circ}$  from A. The submarine at D on realizing that the ship was heading for the island P decides to head straight for the island to intercept the ship.

Using a scale of 1 cm to represent 10 km, make a scale drawing showing the relative position of A, B, D and P.

Hence find:

- (i) The distance from A and D
  - (ii) The bearing of the submarine from the ship when the ship was setting off from B
  - (iii) The bearing of the island P from D
  - (iv) The distance the submarine had to cover to reach the island
19. Four towns R, T, K and G are such that T is 84 km directly to the north of R and K is on a bearing of  $295^{\circ}$  from R at a distance of 60 km. G is on a bearing of  $340^{\circ}$  from K and at a distance of 30 km. Using a scale of 1 cm to represent 10 km, make an acute scale drawing to show the relative positions of the towns.

Find

(a) The distance and bearing of T from K

(b) The bearing of R from G

20. In the figure below, ABCDE is a regular pentagon and M is the midpoint of AB.

DM intersects EB at N. (T7)

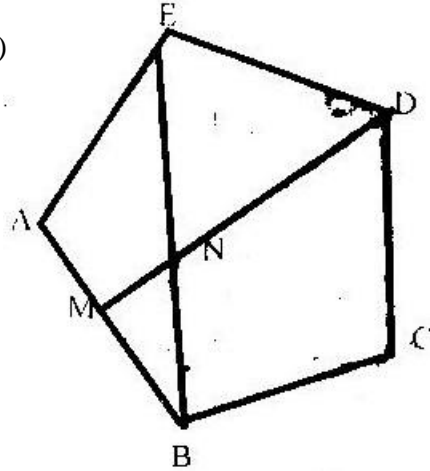

Find the size of

(a)  $\angle BAE$

(b)  $\angle BED$

(c)  $\angle BNM$

21. Use a ruler and compasses in this question. Draw a parallelogram ABCD in which

$AB = 8\text{cm}$ ,  $BC = 6\text{ cm}$  and  $\angle BAD = 75^\circ$ . By construction, determine the

perpendicular distance between AB and CD.

22. The interior angles of the hexagon are  $2x^\circ$ ,  $\frac{1}{2}x^\circ$ ,  $x + 40^\circ$ ,  $110^\circ$ ,  $130^\circ$  and  $160^\circ$ .

Find the value of the smallest angle.

23. The size of an interior angle of a regular polygon is  $156^{\circ}$ . Find the number of sides of the polygon.

**TOPIC 8:**

**COMMON SOLIDS**

1. The figure below shows a net of a prism whose cross – section is an equilateral triangle.

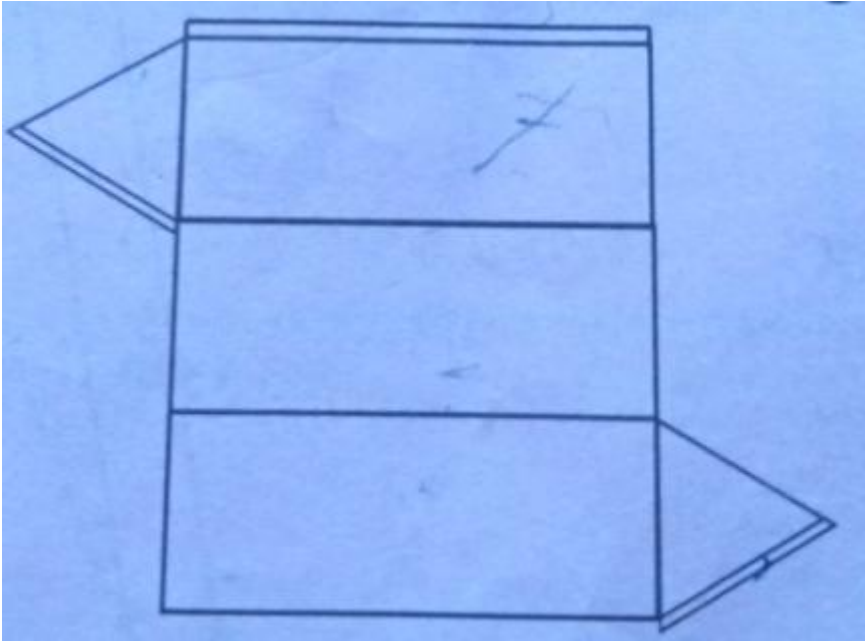

- a) Sketch the prism
- b) State the number of planes of symmetry of the prism.

2. The figure below represents a square based solid with a path marked on it.

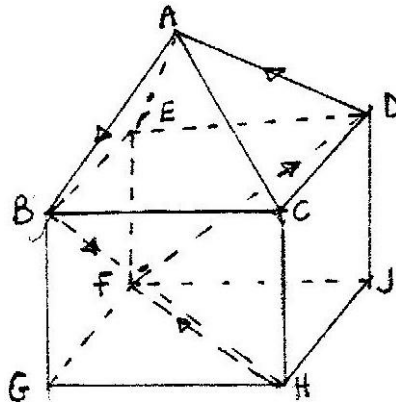

Sketch and label the net of the solid.

3. The figure below represents below represents a prism of length 7 cm

$AB = AE = CD = 2 \text{ cm}$  and  $BC = ED = 1 \text{ cm}$

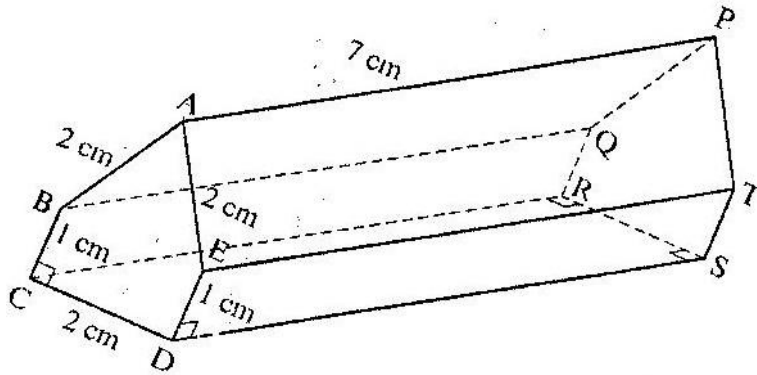

Draw the net of the prism

( 3 marks)

4. The diagram below represents a right pyramid on a square base of side 3 cm. The slant of the pyramid is 4 cm.

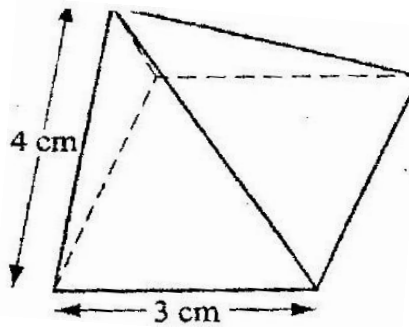

- (a) Draw a net of the pyramid ( 2 marks)
- (b) On the net drawn, measure the height of a triangular face from the top of the Pyramid ( 1 mark)
5. (a) Draw a regular pentagon of side 4 cm ( 1 mark)
- (b) On the diagram drawn, construct a circle which touches all the sides of the pentagon ( 2 marks)

6. The figure below shows a solid regular tetrahedron of sides 6 cm

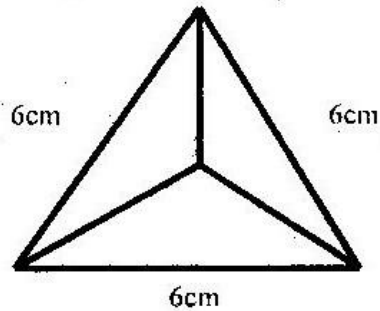

- (a) Draw a net of the solid
- (b) Find the surface area of the solid

7. The figure below shows a solid made by pasting two equal regular tetrahedra

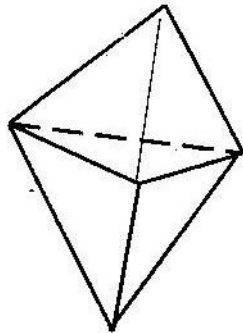

- (a) Draw a net of the solid
- (b) If each face is an equilateral triangle of side 5cm, find the surface area of the solid.



8. (a) Sketch the net of the prism shown below

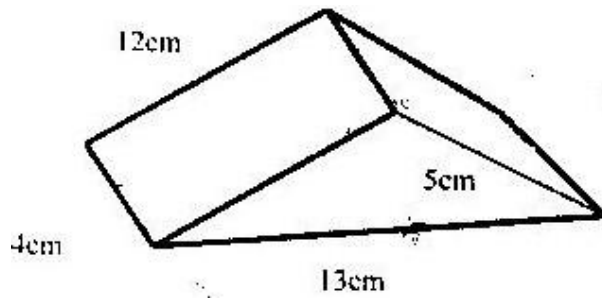

(b) Find the surface area of the solid