

FORM I WORK

TOPIC 1

SIMPLE CLASSIFICATION OF SUBSTANCES.

PAST KCSE QUESTIONS ON THE TOPIC.

1. The diagram below represents a paper chromatogram of pure w, X, and Y. A mixture K contains W and Y only. Indicate on the diagram the chromatogram of

K. (1mk)

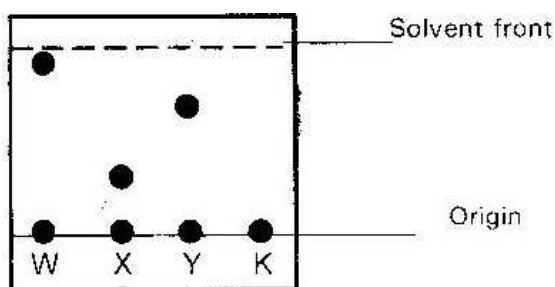

2.

Study the information below and answer the question that follows. A mixture contains the solids; Alum camphor and sugar. The solubility of different liquids is shown in the table below.

solid	Liquid		
	Water	Ethanol	Ether
Alum	Soluble	Insoluble	Insoluble
Camphor	Insoluble	Soluble	Very soluble
Sugar	Soluble	Soluble	Insoluble

Explain how you would obtain a sample of solid sugar from the mixture.

3.

The equation below represents two processes that takes place without any change in temperature.

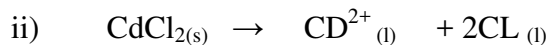
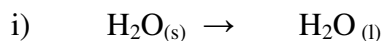

a) Explain why although heat is required for each of the processes to take place, the temperature remained constant in both processes. (1mk)

b) Which of the two processes has a higher enthalpy change ΔH ; Give a reason? (2mks)

4.

The table below gives some properties of gas D and E. (2mks)

Gas	Density	Effect on H_2SO_4	Effect on NaOH .
D	Lighter than air	React to form salt	Dissolve without reacting
E	Heavier than air	Not affected	Not affected

a) Describe how you would obtain a sample of gas E from the mixture of gas D and E

b) Suggest a possible identity of gas D. Give reasons for your answer. (2mks)

5.

Explain how you would separate a mixture of Nitrogen and Oxygen gases given that their boiling points are -196°C and -183°C respectively. (2mks)

6.

In an experiment to separate a mixture of organic liquid “m” (B.P. 56°C) and liquid “n” (B.P. 118°C) a student set up the apparatus shown below.

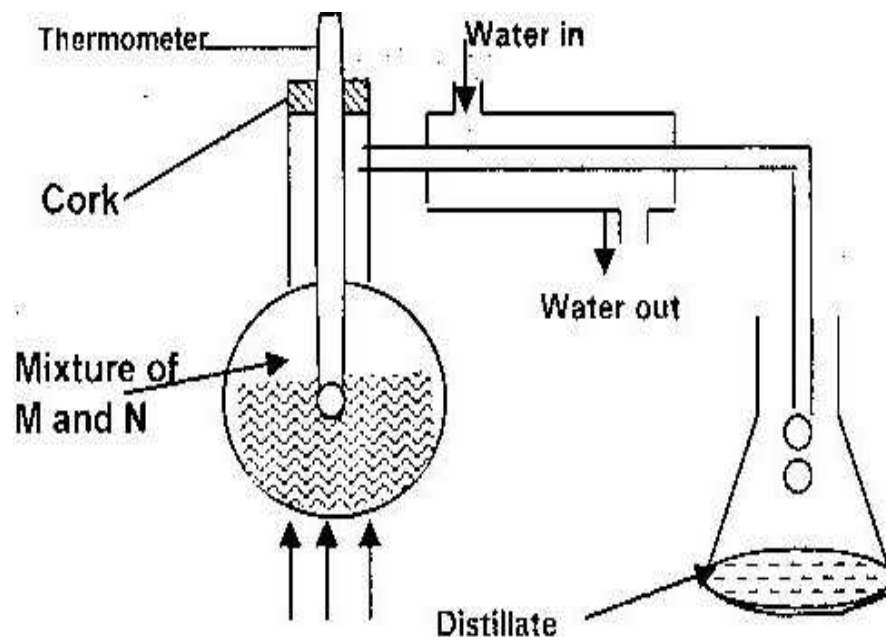

a) Identify two mistakes in the set up. (2mks)

b) What method would the student use to test the purity of the distillates?

(1mk)

7.

Some sodium Chloride was found to be contaminated with Copper (II) Oxide.

Describe how a sample of sodium chloride can be separated from the mixture.

(3mks)

8.

The set up below represents apparatus that may be used to separate a mixture of two miscible liquids “C” and “D” whose boiling points are 80°C respectively.

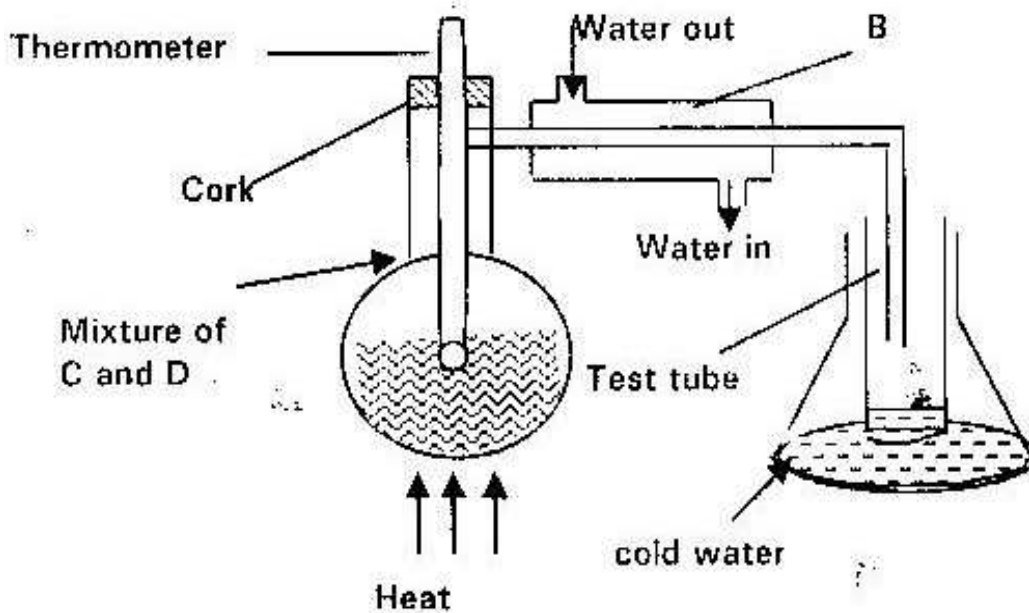

- Name B. (1mk)
- What is the purpose of the thermometer? (1mk)
- Which liquid is collected in the test tube? (1mk)

9. Air was passed through several reagents as shown in the flow chart below.

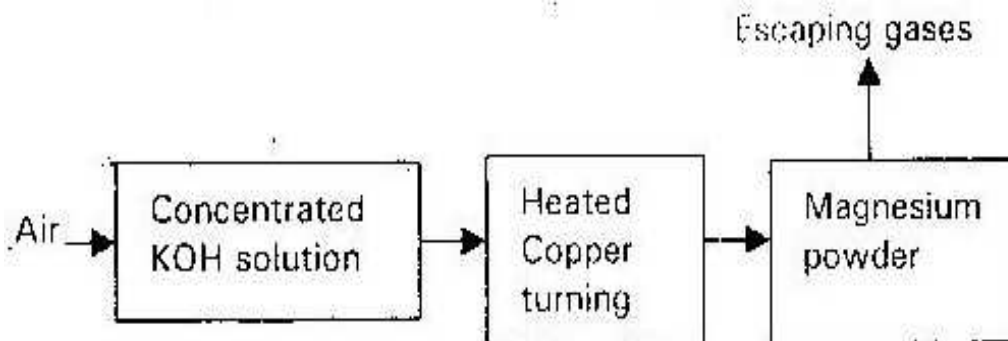

- a) Write an equation for the reaction which takes place in the chamber with magnesium powder. (1mks)
- b) Name one gas which escapes from the chamber containing magnesium. Give a reason for your answer. (2mks)

10. Dry Carbon (II) Oxide gas reacts with heated Lead (II) as shown in the equation below.

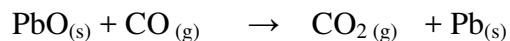

- a) Name the process undergone by the Lead (II) Oxide. (1mk)
- b) Give a reason for your answer (a) above. (1mk)
- c) Name another gas that can be used to perform the same function as Carbon (II) Oxide gas in the above reaction. (1mk)
11. The diagram below shows a Bunsen burner when in use.

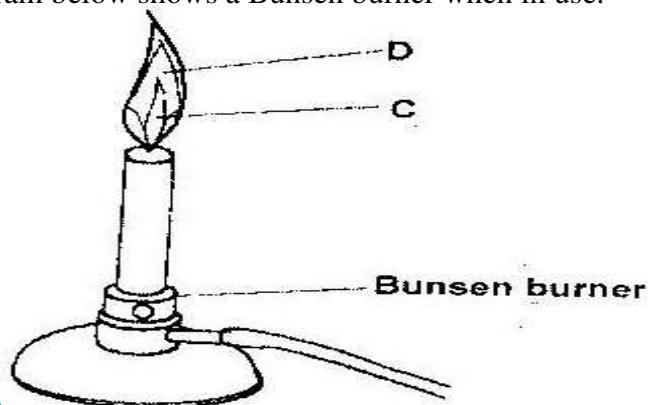

a) Name the region labelled C and D. (2mks)

12. Samples of urine from three participants F, G and H at an international sports meeting were spotted onto a chromatography paper alongside two from illegal drugs A₁ and A₂. A chromatogram was run using methanol. The figure below shows the chromatogram.

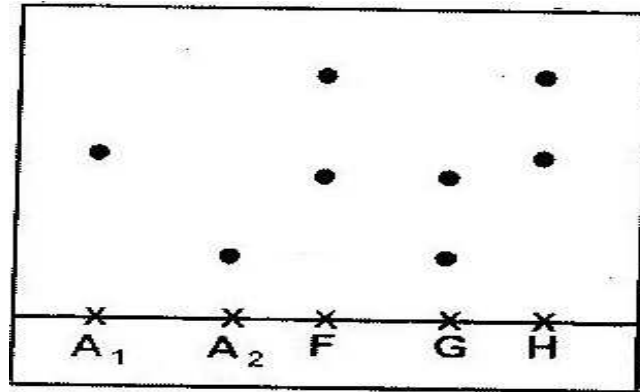

a) Identify the athlete who had used an illegal drug. (1mk)

b) Which drug is more soluble in methanol? (1mk)

13. The graph below is a cooling curve of a substance from gaseous state to solid state.

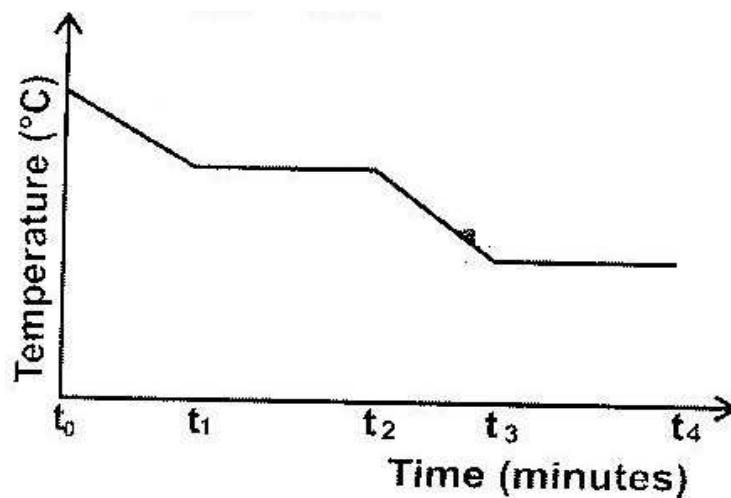

Give the name of the:

a) Process taking place between t_0 and t_1 ; (1mk)

b) Energy change that occurs between t_3 and t_4 (1mk)

14. For each of the following experiments give the observation, the type of change that occurs (physical or chemical) and the formula (e) of any substance(s) formed.

If no new compound (substance) is formed write no new compound formed.

Experiment	Observation	Type of change	Formulae
Add few drops of concentrated sulphuric acid to small amount of sugar ($C_{12}H_{22}O_{11}$)			
A few crystals of Iodine I_2 are heated gently in a test tube.			
Few crystals of Copper (II) Nitrate are heated strongly in a test tube.			
Sodium hydroxide platettes in an evaporating dish are left in humid air for one day.			

15.

a) What method can be used to separate a mixture of ethanol and propanol?

(1mk)

- b) i) Explain how a solid mixture of sulphure and sodium chloride can be separated into solid sulphur and solid sodium chloride. (4mks)
- ii) How can one determine that solid sulphure is pure? (2mks)
- c) The table below gives the solubilities of potassium bromide and potassium bromide and potassium sulphate at 0⁰C and 40⁰C.

Substances	Solubilities in g/100g of water	
	0 ⁰	40 ⁰
Potassium bromide	55	75
	10	12

When aqueous mixture containing 60g of potassium bromide and 7g of potassium sulphate in 100g of water at 80⁰C, some crystals were formed.

- i) Identity the crystals. (1mk)
- ii) Determine the mass of crystals formed. (1mk)
- iii) Name the method used to obtain the crystals. (1mk)
- iv) Suggest one industrial application of the method named in (c) (iii) above (1mk)

16.

Describe the process by which Nitrogen is obtained from air on a large scale.

(4mks)

17. Name the methods by which the following substances could be separated.

- a) Kerosene from crude oil (1mk)
- b) Coloured extract from grass dissolved in ethanol. (1mk)

- c) Aluminium chloride from sodium chloride. (1mk)
- d) Iron fillings from sulphur powder. (1mk)

18. The diagram below represents three methods for collecting gases in the laboratory

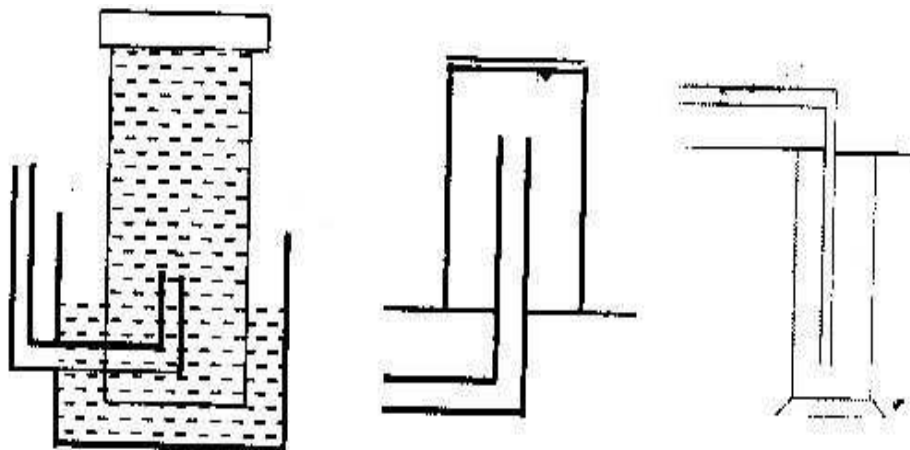

(i) (ii) (iii)

- a) Name the methods shown in the diagram (3mks)
- b) State with reasons the most suitable methods for collecting each of the following gases.
- i) Oxygen (1mk)
- ii) Hydrogen (1mk)
- iii) Carbon (IV) Oxide (1mk)
19. A laboratory technician accidentally mixed liquids suspected to be benzene (B.P. 78°C). He has a problem of separating the mixture and seeks your help. Describe to him. (4mks)
- a) The method he should use
- b) The apparatus he should use
- c) The precautions he should take when carrying out the separation.

20. Study the following chart for laboratory preparation of dry nitrogen.

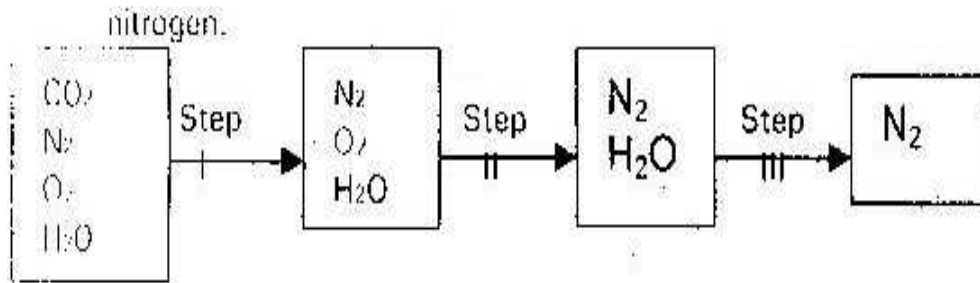

- a) State what happens in step I and II
 - b) Name the compounds which can be used in step I and II respectively. (2mks)
21. Explain how naphthalene could be separated from a mixture of naphthalene and common salt. (2mks)
22. A student added some pure potassium nitrate crystals to cold water and stirred the mixture. A few of the crystals did not dissolve at room temperature.
- a)
 - i) Give a reason why some crystals did not dissolve. (1mk)
 - ii) What would happen if the contents of the mixture in a beaker were warmed? Explain. (2mks)
 - b)
 - i) Name two substances which can be reacted to give Copper (II) Sulphate. (1mk)
 - ii) Write the equation for the reaction between the substances named in b (i) above. (1mk)
 - c) Some Copper (II) sulphate crystals were gently heated in a test tube until no more water was given off.

- i) Draw a diagram of the apparatus that could be used to heat the crystals and collect the water given off. (3mk)
- ii) State what would be observed if the residue in the test tube is cooled and few drops of water is added to it. (1mk)

23. The set up below was used to determine the melting point of naphthalene.

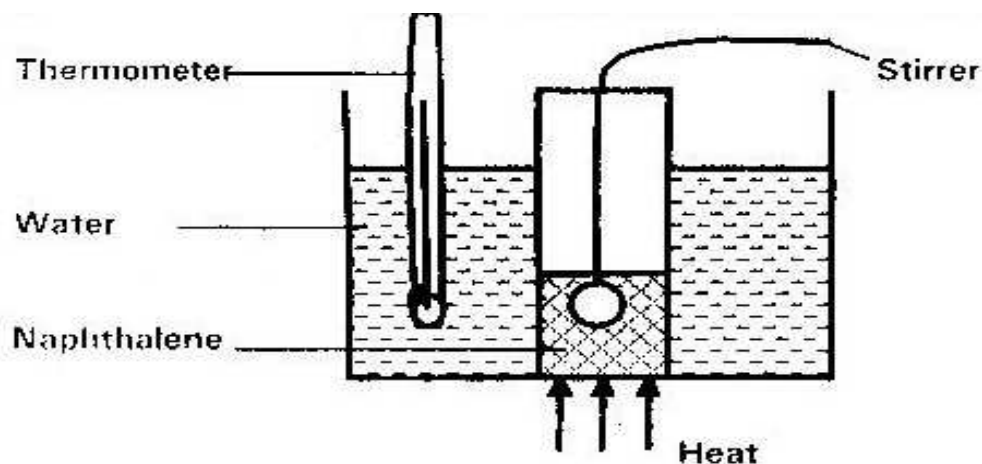

- a) State precautions which should be taken into consideration when carrying out this experiment. (3mks)
- b) State the use of the following in this experiment.
 - i) Thermometer. (1mk)
 - ii) Stirrer (1mk)
 - iii) Boilling water (1mk)

- c) The experimental value of the melting point of naphthalene is 78°C and theoretical value is 80°C . Suggest one reason for this difference. (1mk)

24. The following diagram is used to show that air contains Carbon (IV) Oxide.

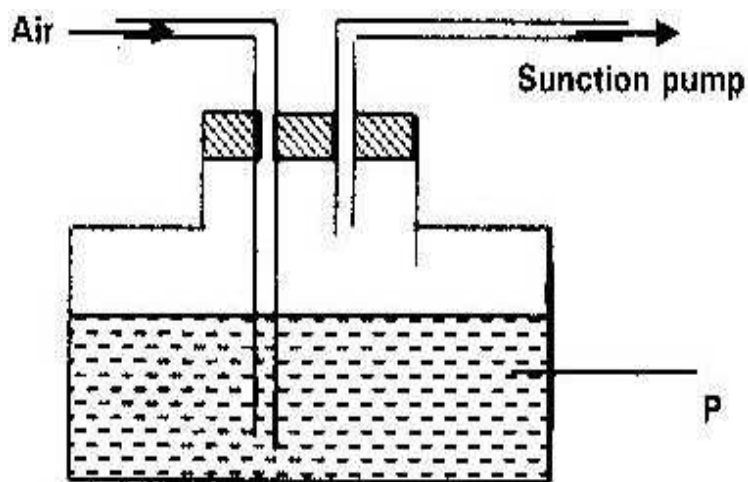

- a) Name liquid "p" (1mk)
- b) State the observation made on liquid "p" which will indicate the presence of carbon (IV) Oxide. (1mk)
- c) Write an equation for the reaction between "p" and Carbon (IV) Oxide. (1mk)
25. Explain why potassium is kept under paraffin while phosphorous under water. (2mks)

26. Study the information below and answer the questions that follow.

Solids	Cold water	Hot water
R	Soluble	Soluble
S	Insoluble	Insoluble
V	Insoluble	Soluble

Briefly explain how you can separate a mixture of solid R, S AND V (3mks)

TOPIC 2

ACIDS, BASES AND INDICATORS

1. What would be observed when aqueous sodium hydroxide is added to aqueous Lead (II) Nitrate? (1mk)
2. Explain why concentrated sulphuric acid is a weaker acid than dilute sulphuric acid? (1mk)
3. When solid calcium carbonate is reacted with excess dilute hydrochloric acid, Carbon (IV) Oxide gas is evolved. The graph below shows a plot of the volume of carbon (IV) Oxide evolved against time.

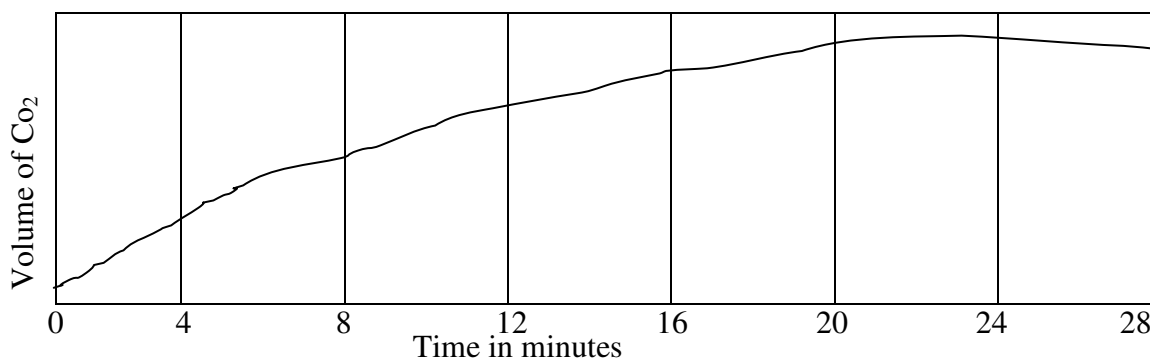

Explain how the evolution of carbon (IV) oxide varies with time. (2mks)

4. Study the flow chart below and answer the question that follows.

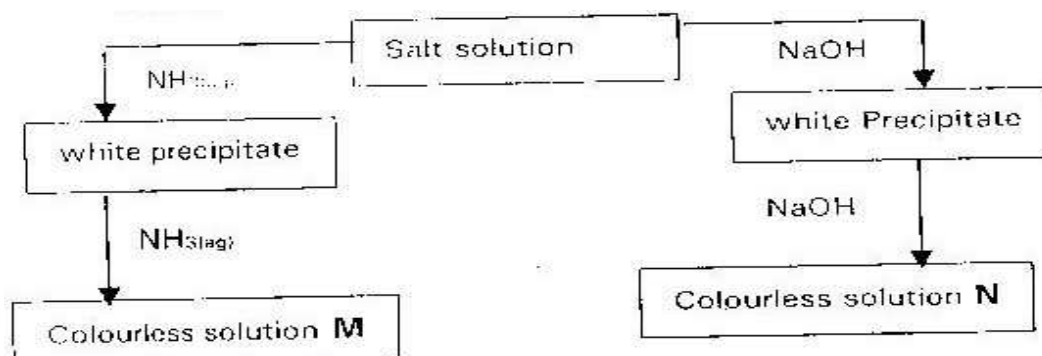

Write the chemical formula for the complex ions in M and N.

5. Explain the following observations. A molar solution of nitrous acid (Nitric (III) acid has a PH of 2 whereas a one molar solution of hypochlorous acid (Chloric (I) acid has a PH of 4. (2mks)
6. Solutions may be classified as strong basic, weakly acidic, strong acidic. The information below gives solutions and their PH values. Study it and answer the questions that follow.

Solutions	PH values
B	1.5
C	6
D	14

Classify the solutions in the table above using the stated classification (3mks)

7. Explain how you would distinguish between a carbonate and a sulphite using dilute acid and blue litmus paper. (1mk)

8. In the equation below, identify the reactant that act as an acid and explain how you would arrive at your choice.

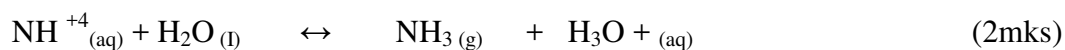

9.

Describe how the following reagents can be used to prepare Lead sulphate, solid potassium sulphate, solid lead carbonate, dilute nitric acid and distilled water

(2mks)

10. Distinguish between strong and weak acid. Give an example of each. (2mks)

11.

Describe how a solid sample of Lead (II) chloride can be prepared using the following reagents. Dilute nitric acid (Nitric (V) acid), dilute Hydrochloric acid and lead (II) carbonate.

(2mks)

12.

A bee keeper found that when stung by a bee, application of a little solution of sodium hydrogen Carbonate help to relieve the irritation from the affected area.

Explain.

(2mks)

13.

State and explain the observations that would be made when a few drops of concentrated sulphuric acid are added to a small sample of hydrated copper (II) sulphate.

(2mks)

14.

Dg of potassium hydroxide were dissolved in distilled water to make 100cm^3 of the solution required 50cm^3 of solution. 50cm^3 of 2m Nitric (V) acid for complete neutralization. Calculate the mass of d of potassium hydroxide.

Relative molecular mass of KOH = 56



15.

a) A few drops of freshly prepared iron (II) sulphate solution was added to potassium Nitrate solution in a test tube. Concentrated sulphuric acid was then carefully added to the mixture. State the observation that was made.

(1mk)

b) Write an equation for the reaction that occurs when solid potassium nitrate is strongly heated.

(1mk)

16. The pH of a sample of soil was found to be 5.0. An agricultural officer recommended the addition of calcium oxide in the soil. State two functions of calcium oxide in the soil.

(2mks)

17.

18. In an experiment 30cm^3 of 0.1M sulphuric acid were reacted with 30cm^3 of 0.1M sodium Hydroxide.

a) Write an equation for the reaction that took place

(1mk)

b) State the observations that were made when both blue and red litmus papers were dropped into the mixture.

(1mk)

c) Give a reason for your answer in (b) above.

(1mk)

19.

The following tests were carried out on separate portions of a colorless solution S.

	Tests	Observation
i)	Addition of dilute Hydrochloric acid to the first portion of S.	No observable changes.
ii)	Addition of aqueous ammonia to the third portion of s	White precipitate was formed which dissolved in excess of aqueous ammonia.
iii)	Addition of aqueous ammonia to the third portion of S.	White precipitate was formed which dissolved in excess of aqueous ammonia.

- (a) From the information in test (i) name action which is not present in solution S. (1 mk)
- (b) Identify a cation which is likely to be present in solution S. (1 mk)
- (c) Write an ionic equation for the reaction which takes place in test (II). (1 mk)

20.

In an experiment, equal amounts of magnesium powder were added into test tubes 1 and 2 as shown below.

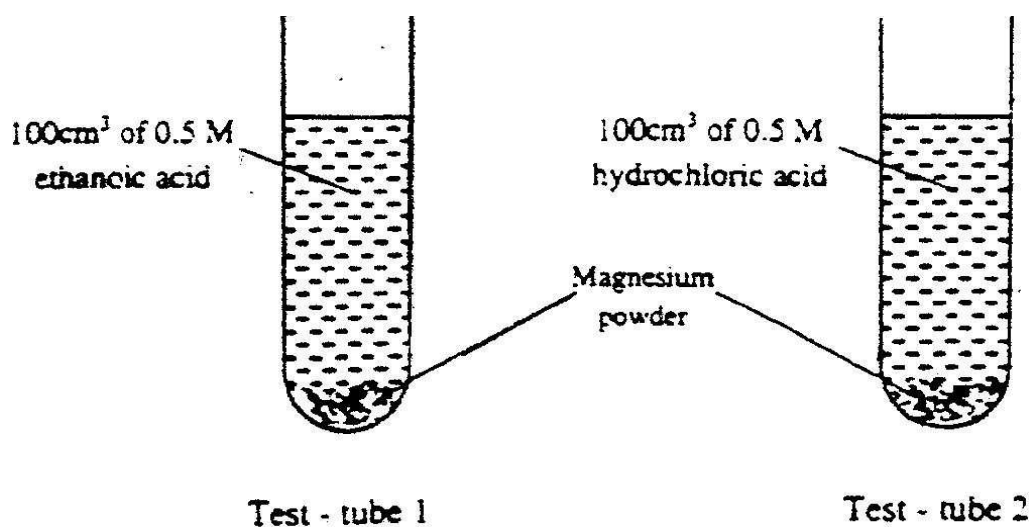

Explain why the amount of Hydrogen gas liberated in test tube 2 is greater than in test tube 1 after 5 minutes. 3 mks

21.

Ammonia gas was passed into water as shown below.

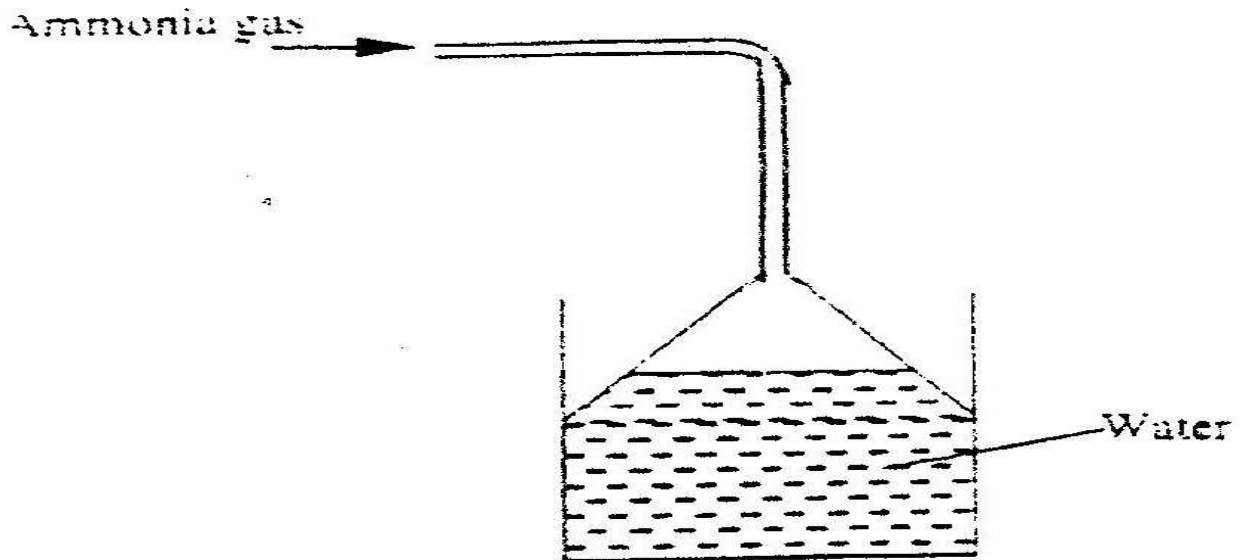

- (a) When a red litmus paper was dropped into the resulting solution, it turned blue. Give a reason for this observation. (1 mk)
- (b) What is the function of the funnel? (1 mk)

22.

Zinc (II) Oxide reacts with acid and alkalis.

- (a) Write the equation for the reaction between Zinc (II) Oxide and
- (i) Dilute sulphuric acid (1 mk)
- (ii). Sodium hydroxide solution. (1 mk)
- (b) What property of Zinc oxide is shown above by the reaction (a) above? (1 mk)

23.

Equal volumes of 1M monobasic acid L and M were each reacted with excess magnesium turnings. The table below shows the volumes of the gas produced after one minute.

Acids	Volume of gas in cm ³
L	40
M	100

Explain the difference in the volumes of the gas produced (2mks)

24.

When a few drops of aqueous ammonia were added to Copper (II) Nitrate solution a light blue precipitate was formed. On addition of more aqueous ammonia a deep blue solution was formed. Identify the substance responsible for the

(a) Light blue precipitate (1 mk)

(b) Deep blue precipitate (1 mk)

25.

When a student was stung by a nettle plant, a teacher applied an aqueous solution of ammonia to the affected area of the skin and the student was relieved of pain.

Explain. (2mks)

26.

In an experiment, a few drops of concentrated nitric acid were added to aqueous iron (II) sulphate in a test tube. Excess sodium hydroxide solution was then added to the mixture.

- (a) State the observations that were made when
- (i) Concentrated nitric acid was added to aqueous iron (II) sulphate (1 mk)
- (ii) Excess sodium hydroxide was added to the mixture. (1 mk)
- (b) Write an ionic equation for the reaction which occurred in (a) (ii) above. (1 mk)

27. The table below shows the tests that were carried out on solid N and the observation made.

I	Test	Observations
II	Dilute hydrochloric acid was added to solid N.	A colourless solution was formed.
III	To the colourless solution obtained in test II, excess sodium hydroxide solution added.	A white precipitate was formed which dissolved to form a colourless solution.

Write the formula of the anion in:

- a) Solid N (1mk)
- b) The colourless solution formed in test II. (1mk)
28. Zinc reacts with both concentrated and dilute sulphuric (VI) acid. Write equations for the two reactions. (2mks)

29.

A compound whose general formula is $M(OH)_4(aq)$ reacts as shown by the equation below.

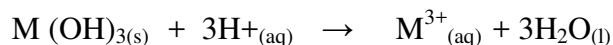
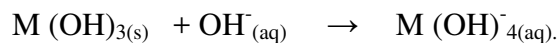

- a) What name is given to compounds which behave like $M(OH)_3(s)$ in the two reactions below. (1mk)
- b) Name two elements whose hydroxides behave like that of M. (2mks)
30. Study the flow chart below and answer questions that follow.

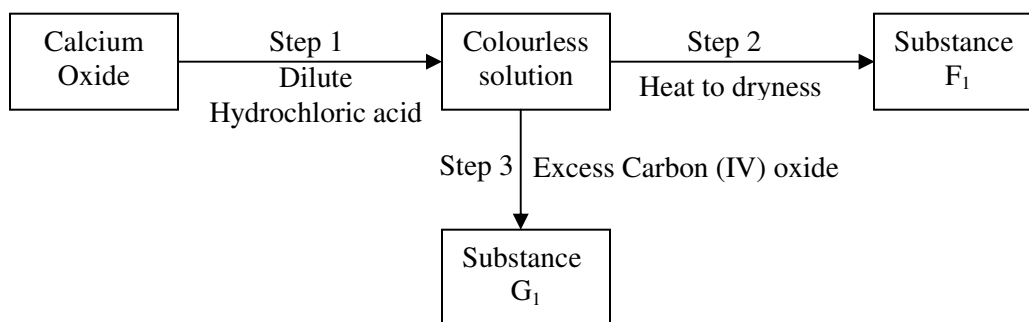

- a) Give the name of the process that takes place in step 1. (1mk)
- b) Give:
- i) The name of substance G_1 (1mk)
- ii) One use of substance F_1 (1mk)

31. a) Give the name of each of the processes described below which takes place when the salt are exposed to air for some time.

i) Anhydrous Copper (II) Sulphate becomes blue. (1mk)

ii) Magnesium chloride forms an aqueous solution. (1mk)

iii) Fresh crystals of sodium carbonate ($\text{Na}_2\text{CO}_3 \cdot 10\text{H}_2\text{O}$) become covered with a white powder of formula $\text{Na}_2\text{CO}_3 \cdot \text{H}_2\text{O}$. (1mk)

b) Write the formula of the complex ion formed in each of the reactions described below.

i) Zinc Oxide dissolves in excess ammonia solution. (1mk)

ii) Copper hydroxide dissolves in excess ammonia solution. (1mk)

c) A hydrated salt has the following composition by mass;

Iron 20.2%, Oxygen 23.0%, Sulphur 11.5%, water 45.3%. Its relative formula mass is 278.

i) Determine the formula of hydrated salt were dissolved in distilled water and the total volume made to 250 cm^3 of solution. Calculate the concentration of the salt solution in moles per litre. (2mks)

32.

The reaction between bromine and methanoic acid at 300°C proceeds according to the information given below.

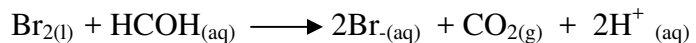

The table below shows the change in concentration of Bromine liquid against time.

Concentration of Br _{2(l)} mole/dm ³	Time in minutes
10.0 x 10 ³	0
8.1 x 10 ³	1
6.6 x 10 ³	2
4.4 x 10 ³	4
3.0 x 10 ³	6
2.0 x 10 ³	8
1.3 x 10 ³	10

- a) Plot a graph of concentration of bromine (vertical axis) against time. (3mks)
- b) From the graph determine
- The concentration of bromine at the end of 3 minutes. (1mk)
 - The rate of reaction at t= 1 ½ minute. (2mk)
- c) Explain how the concentration of bromine affects the rate of the reaction. (2mks)
- d) On the same axis, sketch the curve that would be obtained if the reaction was carried out at 20⁰C and label the curve as curve II. Give a reason for your answer.

33.

The table below gives the volumes of gas produced when different volumes of 2M Hydrochloric acid were reacted with 0.6g of magnesium powder at room temperature.

Volume of 2m HCL in cm ³	Volume of gas (cm ³)
0	0
10	240
20	360
30	600
40	600
50	600

- a) Write an equation for the reaction between magnesium and Hydrochloric acid. (1mk)
- b) On the grid provided plot a graph of the volume of gas produced (vertical axis) against the volume of acid added (note that before the reaction comes to a completion the volume of gas produced is directly proportional to the volume of acid added).
- c) From the graph, determine
- i) The volume of the gas produced if 12.5cm³ of 2M Hydrochloric acid had been used. (1mk)

ii) The volume of 2M Hydrochloric acid which react completely with 0.6g of magnesium powder. (1mk)

d) State and explain the effect on the rate of production of the gas if

i) 0.6g of magnesium ribbon was used instead of magnesium powder.

ii) 3m Hydrochloric acid was used instead of 2M Hydrochloric acid.

(2mks)

e) Given that one mole of the gas occupies 2400cm^3 at room temperature.

Calculate the relative atomic mass of magnesium.

(3mks)

34. a) Name one ore from which copper of extracted.

b) The flow chart below shows a sequence of reactions starting with copper.

Study it and answer the questions that follow.

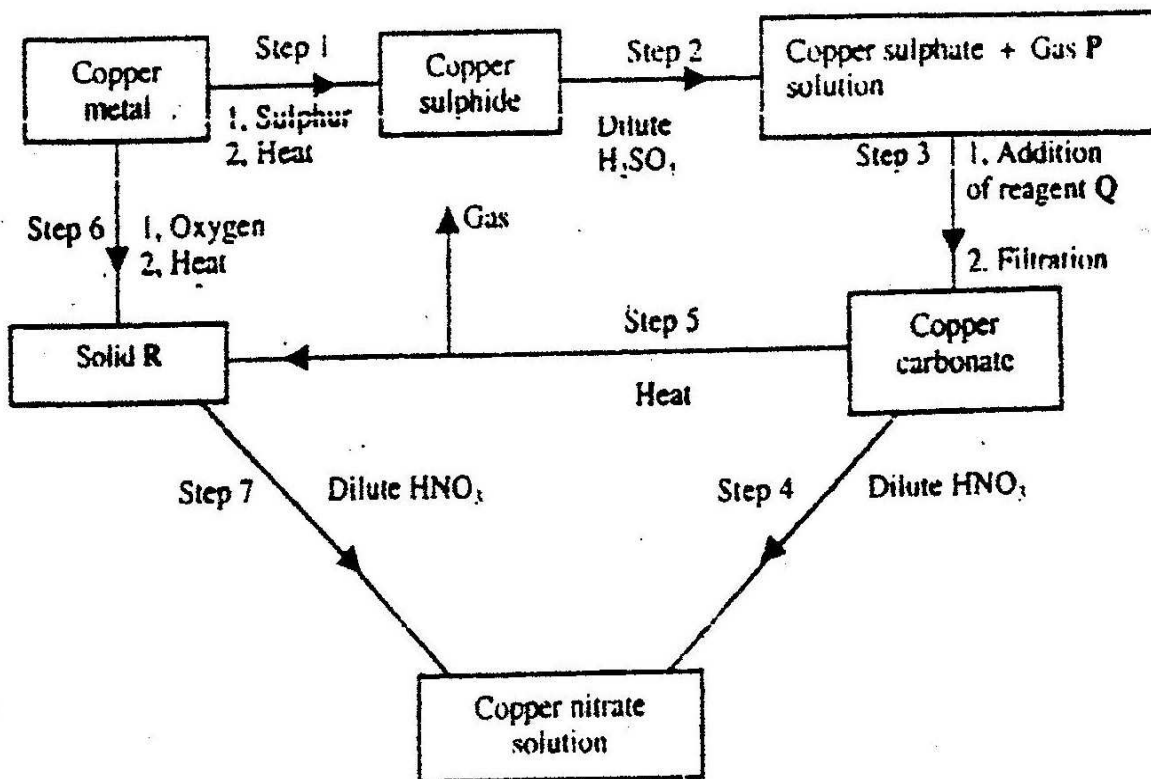

- i) Identify gas P (1mk)
Reagent Q (1mk)
Solid R (1mk)
- ii) Write an equation for the reaction that takes place in step 5. (1mk)
- iii) State the observations made in steps 4 and 7. (2mks)
- Step 4 _____
Step 7 _____
- c) Bronze is an alloy of copper and another metal.
- i) Name the other metal
- ii) Give one use of bronze.

35. The graph below shows how the PH value of soil in a farm changed over a period of time.

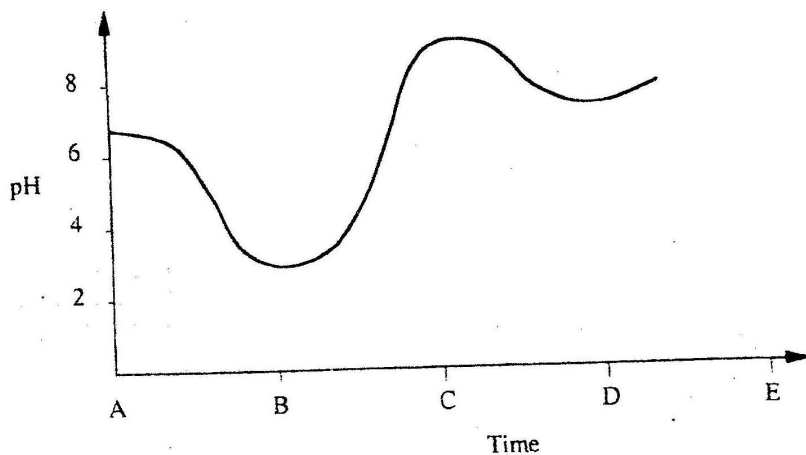

- i) Describe how the PH of the soil is determined. (2mks)
- ii) State one factor that may have been responsible for the change in the soil PH in the time interval AB (1mk)

36. The following data gives the PH value of solution P, Q and R.

Solution	PH value
P	13.6
Q	6.9
R	1.3

- i) Which solution would produce Carbon (IV) Oxide when reacted with Copper (II) Carbonate? (1mk)
- ii) What would be the colour of solution “P” after adding a few drops of phenolphthalein indicator? (1mk)
37. a) What is basicity of an acid? (1mk)
- b) With reason write down the basicity of ethanoic acid. (CH₃COOH). (2mks)

38. An indicator established the following equilibrium when dissolved in water.

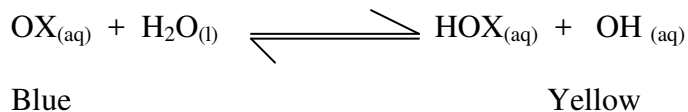

State and explain the colour of this indicator in

- i) Acidic medium (1mk)
- ii) Alkaline medium (1 mk)

39. Study the flow chart below and answer the questions that follow:

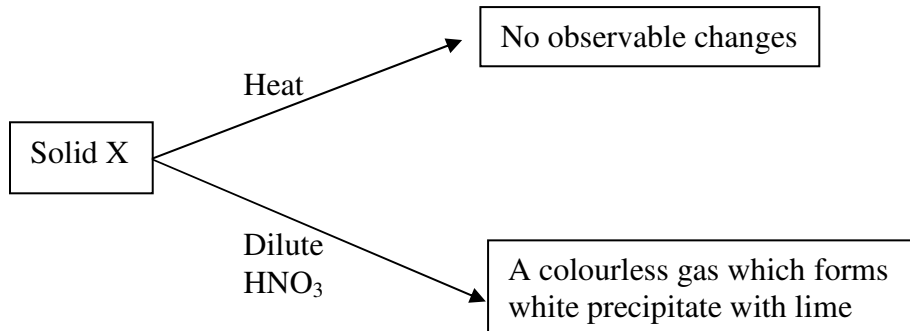

Write the formula of the ions in solid X. (1mk)

40. The table below shows the PH values of certain solutions

Solution	A	B	C	D
PH values	8	5	7	11

Which of the solutions is most likely to be solutions of

- i) Common salt (1mk)
 - ii) Lime water (1mk)
 - iii) Orange juice (1mk)
 - iv) Household soap (1mk)
41. The table below shows PH values for some solutions.

Solution	A	B	C	D
PH values	13.5	7	1	6.5

- a) What solution reacts vigorously with magnesium metal? (1mk)
- b) Which solution forms complex ions with zinc (II) Oxide? (1mk)

- c) Which solution is likely to be that of lemon juice? (1mk)
42. a) Freshly prepared iron (II) sulphate solution was reacted with a few drops of Sodium Hydroxide solution. State the observation made. (1mk)
- b) State and explain the observations made when the products formed in the above reaction stand for some time. (2mks)
- i) Observation
- ii) Explain

43. Explain the differences between strong and weak acids.

44. The following table shows the PH values of solutions A, B, C and D. (2mks)

Solution	PH values
A	9.8
B	2.0
C	5.2
D	12.0

Which one of the solutions, $\text{NaOH}_{(aq)}$, $\text{CH}_3\text{COOH}_{(aq)}$, $\text{HCL}_{(aq)}$ and $\text{NH}_3_{(aq)}$

correspond to solutions A, B, C and D. (2mks)

45. When ion fillings were dissolved in dilute sulphuric acid a pale green solution formed and a colourless gas was given off. The solution filtered and divided into two portions.
- a) Write an equation for the reaction. (1mk)
- b) To the first portion of the filtrate, aqueous ammonia was added drop wise until in excess.
- i) What was observed? (1mk)

- ii) Write an ionic equation for the reaction (1mk)
- c) To the second portion of the filtrate, dilute sulphuric acid was added and warmed. A few drops of concentrated Nitric acid were added and a mixture heated. Brown fumes were given off and a brown solution removed.
- i) Write an equation for this reaction. (1mk)
- ii) What was the purpose of concentrated Nitric acid in this reaction? (1mk)
- d) To the brown solution formed in (c) above zinc metal was added. The mixture was the left to stand for 30 minutes.
- i) What observations would be during and after 30 minutes? (2mks)
- ii) What is the role of zinc metal? (1mk)
- iii) Write an ionic equation for this reaction. (1mk)

TOPIC 3

AIR AND COMBUSTION

1.

Study the experiment set up represented by the diagram below and answer the question that follows.

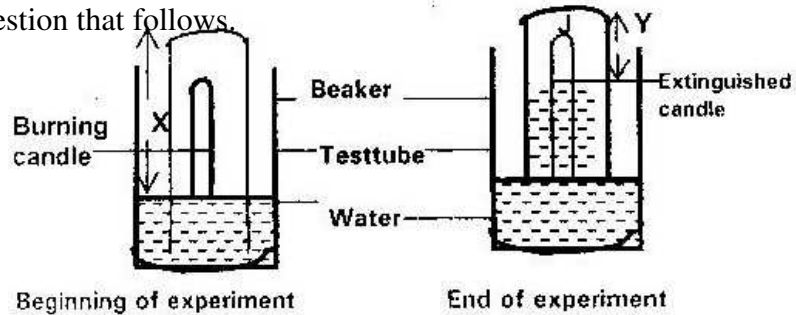

a) Explain what would be observed if red and blue litmus papers were dipped into the water at the end of experiment. (2mks)

b) Write an expansion in terms of X and Y to show the (%) percentage of gas used by the burning candle. (1mk)

2.

The diagram below represents two iron nails with some parts wrapped tightly with zinc and copper strips respectively.

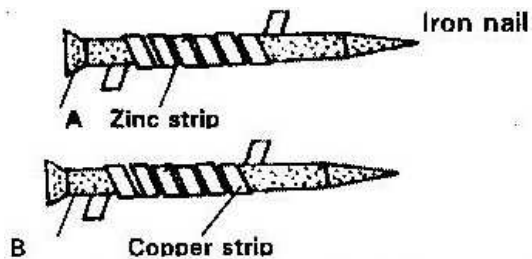

What observations would be made at the exposed points A and B if the wrapped nails are left in the open for several months? Explain. (3mks)

3.

In an experiment, rods of metals P, Q and R were cleaned with a sand paper and placed in a beaker containing water. Another set of rods was also cleaned and placed in a beaker containing dilute acid. After placing the rods in the two liquids bubbles of gas were seen around some of the rods as shown in the diagram below.

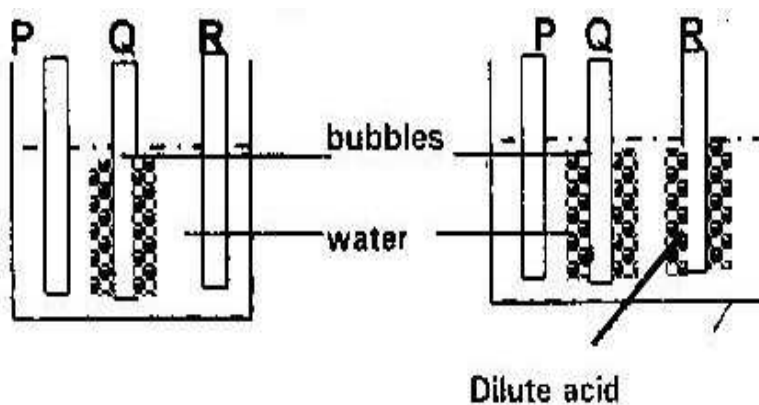

- Why was it necessary to clean the rods with sand paper before dipping them into the liquids? (1mk)
- Arrange the three metals in order of their reactivity starting with the most reactive. (1mk)

4.

When magnesium is burnt in air it reacts with oxygen and nitrogen gas giving a white ash. Write two equations for the two reactions that take place. (2mks)

5.

Oxygen reacts with the elements phosphorous, sulphur and chlorine to form oxides in which the elements is in its highest oxidation number. The table below gives the oxide of sulphur and its highest oxidation number. Complete the table for phosphorous and chlorine. (Atomic number p=15, s=16, Cl= 17) (2mks)

Elements	Oxides	Highest oxidation number
P		
S	SO ₃	+6
Cl		

6.

Write an equation for the reaction that takes place when carbon (II) Oxide gas is passed over heated Lead (II) Oxide. (1mk)

7. 1997: pp 1A q. 1

The set up below was used to study some properties of air

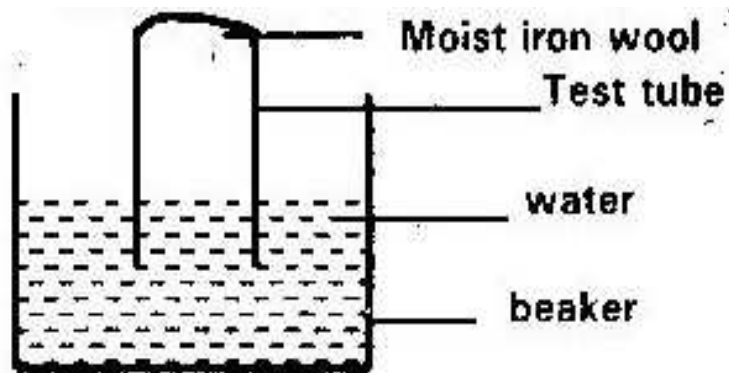

State and explain two observations that would be made at the end of the experiment.

(3mks)

8.

Give the formula of an oxide which reacts both dilute Hydrochloric acid and hot concentrated sodium hydroxide.

9.

In an experiment a certain volume of air was passed repeatedly from syringe over heated excess zinc powder as shown in the diagram below.

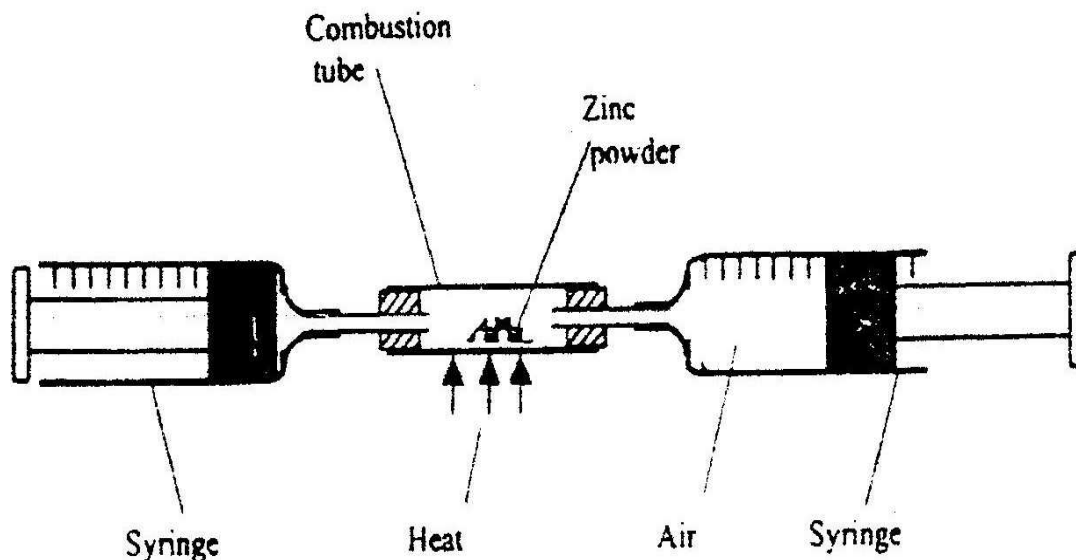

The experiment was repeated using excess magnesium powder. In which of the experiments was the change in volume of air greatest? Give reasons. (3mks)

10.

State and explain the change in mass that occurs when the following substances are separately heated in open crucibles.

i) Copper metal

ii) Copper (II) Nitrate

(3mks)

11.

The diagram below shows an iron bar, which supports a bridge. The iron is connected to a piece of magnesium metal.

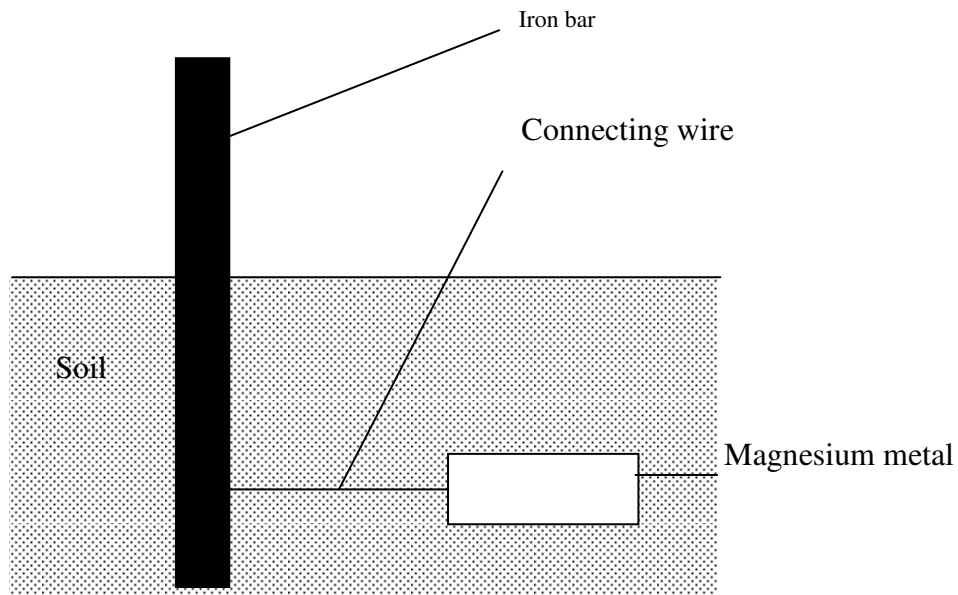

Explain why it is necessary to connect the piece of magnesium metal to the iron bar. (3mks)

12.

Explain why magnesium continues to burn in a gas jar full of Sulphur (IV) Oxide while a burning splint would be extinguished.

13.

The diagram below is a set up for the laboratory preparation of oxygen gas.

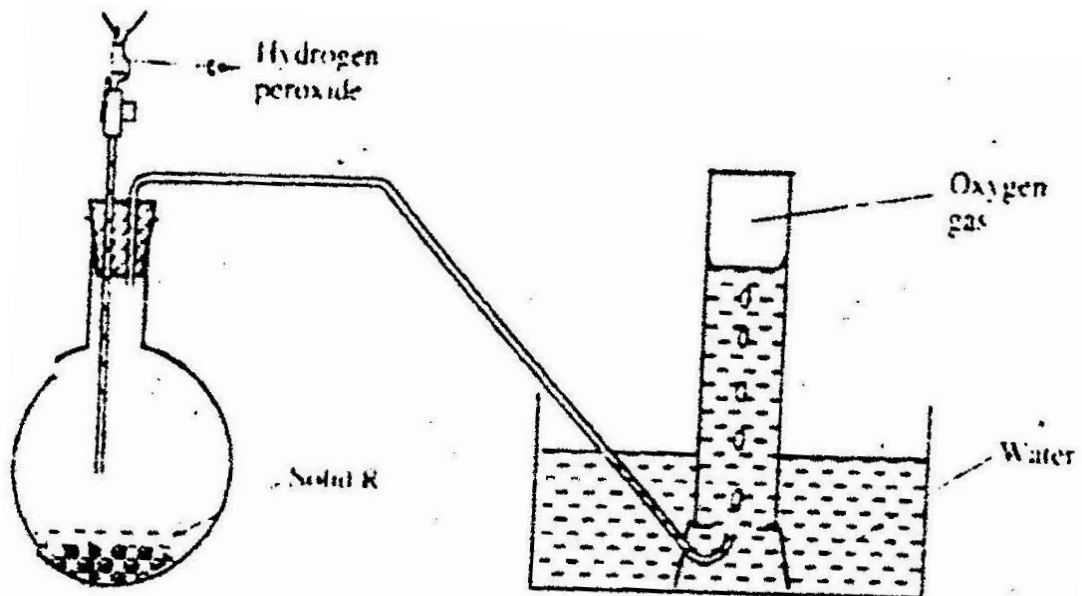

- a) Name solid R. (1mk)
 - b) Write an equation for the reaction that takes place in the flask. (1mk)
 - c) Give one commercial use of oxygen.
14. Nitrogen (II) Oxide and nitrogen (IV) Oxide are some of the gases released from car exhaust pipes. State these gases affect the environment. (2mks)
15. The set up below was used to obtain a sample of iron.

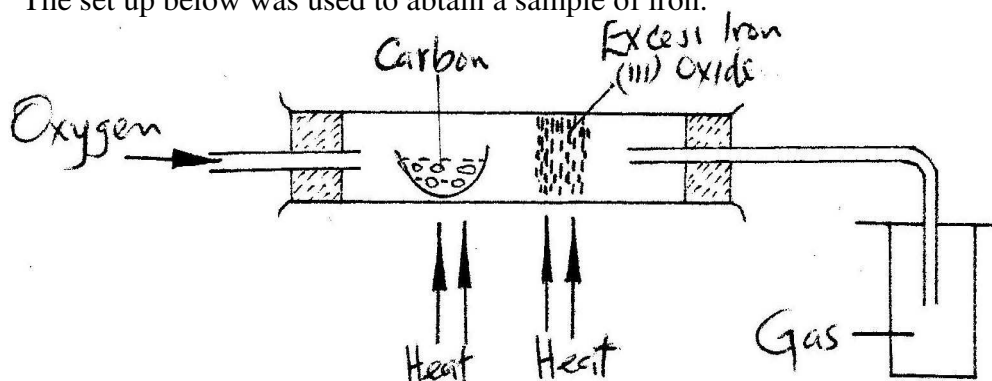

Write two equations which occur in the combustion tube. (2mks)

16.

The flow chart below outlines some of the process involved during extraction of copper from pyrites. Study it and answer the questions that follow.

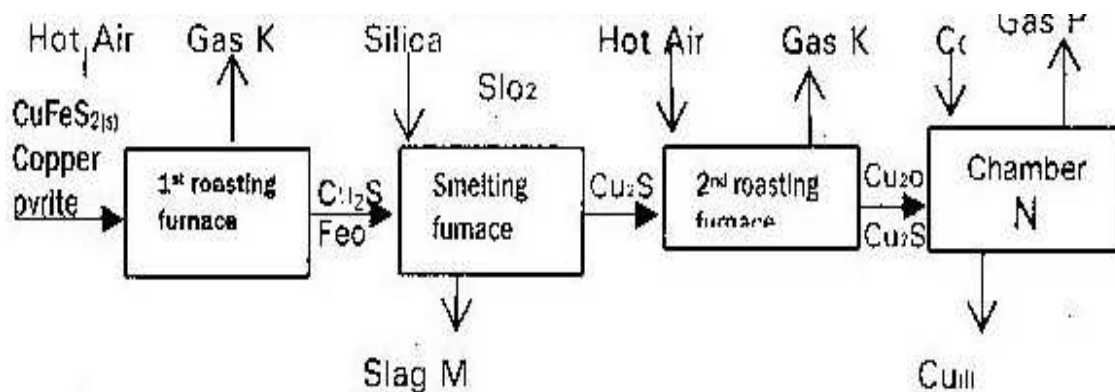

- a)
 - i) Name gas K. (1mk)
 - ii) Write an equation for the reaction that takes place in 1st roasting furnace. (1mk)
 - iii) Write the formula of the cations present in the slag M (1mk)
 - iv) Identify gas P. (1mk)
 - v) What name is given to the reaction that takes place in chamber N? Give a reason for your answer. (2mks)
- b) Copper obtained from chamber N is not pure. Draw a labelled diagram to show the set up you would use to refine the copper by electrolysis. (2mks)
- c) Given that the mass of copper obtained from the above extraction was 210 kg, determine the percentage purity of the ore (copper pyrite) if 810 kg of it was fed to 1st roasting furnace. $\text{Cu} = 63.5$, $\text{Fe} = 56.0$, $\text{S} = 32.0$ (3mks)

d) Give two effects that this process could have on the environment. (2mks)

17.

The table below gives the information about the major constituents of crude oil.

Study it and answer the questions that follow.

Constituents	Boiling point in $^{\circ}\text{C}$
Gases	Below 40
Petrol	49-175
Kerosene	175-250
Diesel oil	259-350
Lubricating oil	350-400
Bitumen	Above 400

- i) Which one of the constituent of crude oil has molecules with the highest number of carbon atoms? (2mks)
- ii) Name the process you would use to separate a mixture of petrol and diesel and explain how the separation takes place. (2mks)
- iii) Explain why constituents of crude oil do not have sharp boiling points. (2mks)
- iv) a) Name one gas that is likely to be a constituent of crude oil and write its formula. (2mks)
- b) What conditions could cause a poisonous gas to be formed when kerosene is burnt. Explain. (2mks)
- c) Give one use of bitumen. (1mk)

18.

The diagram below shows a set up used by a student in an attempt to prepare collect oxygen gas

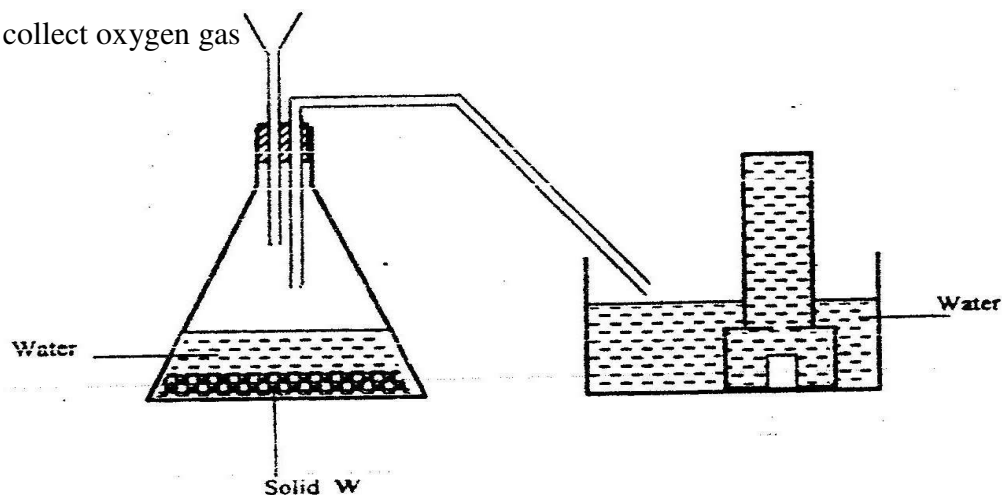

- a) i) Complete the diagram by collecting the mistakes in it. (2mks)
- ii) Identify solid w. (1mk)
- b) A piece of phosphorous was burnt in excess air. The amount of hot water to make a solution.
- i) Write an equation for the burning of phosphorous in excess air. (1mk)
- ii) The solution obtained in (b) above was found to have a PH of 2.0. Give reasons for this observation. (2mks)
- c) Explain why cooking pots made of aluminium do not corrode easily when exposed to air. (1mk)
- d) The reaction between sulphure (IV) Oxide and oxygen to form Sulphur (VI) Oxide per day (condition for the reaction a catalyst, 2 atmospheric pressure and temperature between 400⁰ 500⁰C)

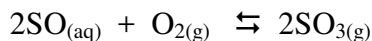

Factory manufacturing sulphuric acid by contact process produces 350kg of sulphur trioxide per day (conditions) for the reaction catalyst. 2 atmospheres pressure and temperatures between 400 – 500 °C.

- i) What is meant by an exothermic reaction? (1mk)
- ii) How would the yield per day of sulphur trioxide be affected if temperatures lower than 400°C are used? Explain. (1mk)
- iii) All the sulphur (VI) Oxide produced was absorbed in concentrated sulphuric acid to form oleum.

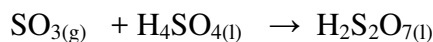

Calculate the mass of oleum that was produced per day.

(S+ 32.0, O= 16: H 1.0) (3mks)

19.

- a) Fractional distillation of liquid air usually produces nitrogen and oxygen as the major by-product.
 - i) Name one substance that is used to remove carbon (IV) Oxide from air before it is changed into liquid. (1mk)
 - ii) Describe how liquid Nitrogen gas is obtained from liquid air. Boiling points; Nitrogen = -196°C; Oxygen = -183°C. (1mk)

b) Study the flow chart below and answer the questions that follows

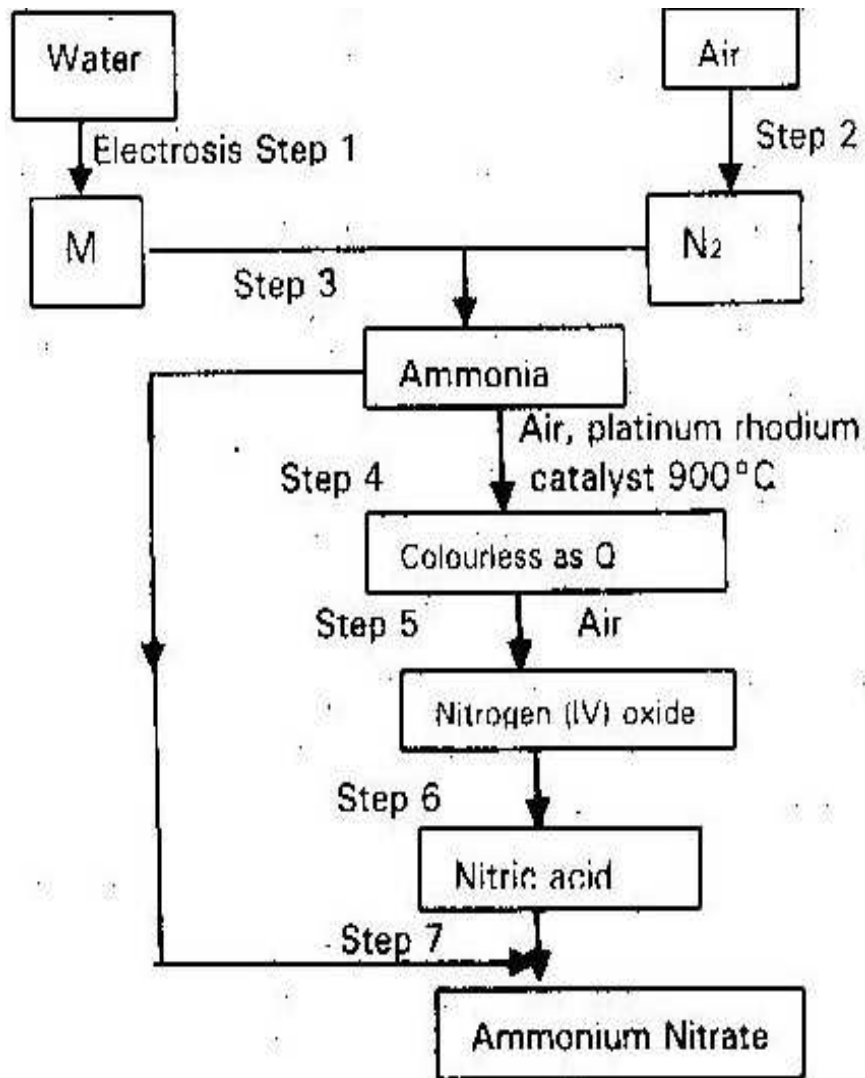

- i) Name element M. (1mk)
- ii) State and explain the change in mass that is likely to occur in tube N by the end of the experiment. (2mks)
- iii) Name two gases that come out through tube M. (1mk)

iv) Write an equation for the reaction in stem 7. (1mk)

v) Give one use of Ammonium –Nitrate. (1mk)

c) State and explain the observations that would be made if a sample of sulphur is heated with concentrated Nitric acid. (Nitric (V) acid).

20.

a) Candle wax is mainly a compound consisting of two elements. Name the two elements

b) The up below was used to investigate the burning of candle. Study it and answer the questions that follow.

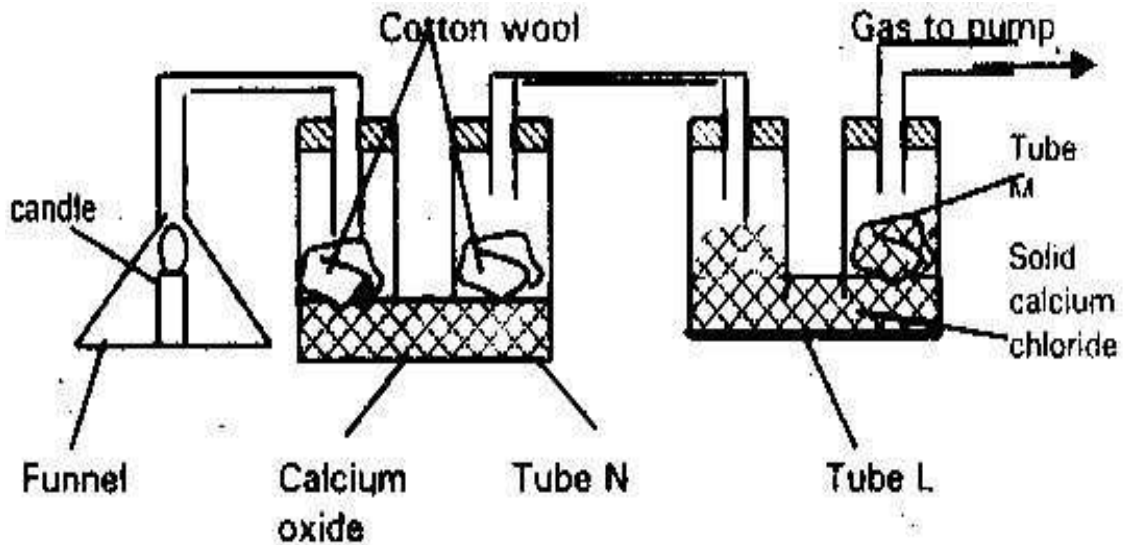

i) What would happen to the burning candle if the pump were turned off? Give reasons. (3mks)

ii) State and explain the change in mass that is likely to occur in tube N by the end of the experiment. (2mks)

iii) Name another substance that would be used in place of calcium oxide. (1mk)

21. Why is iron not used to make steam boilers? (1mk)

22. Study the arrangement below and answer the questions that follows.

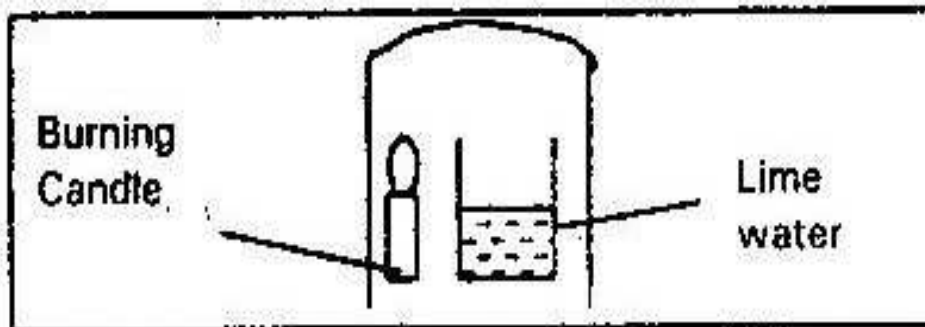

Explain what happens to the lime water after some time. (1mk)

23. When air is bubble through pure water (Ph 7.0). The PH drops to 6.0. Explain why. (1mk)

24. A white compound was moistened with a little concentrated Hydrochloric acid and placed over a flame. A yellow flame was observed. Identify the metallic ions in the compound. (1mk)

25. Magnesium ribbon was burned in a gas jar of Nitrogen. A few drops of water were then added to the jar. Write equation for the reactions in the jar. (2mks)

26. The diagram below shows an experiment to compare the heating effect of luminous and non luminous flame.

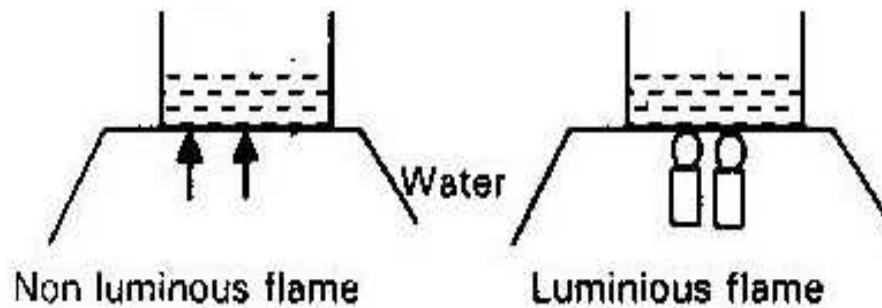

- a) What was observed at the bottom of each beaker at the end of the experiment? (1mk)
- b) Which sample of water boils first? Give a reason for your answer. (2mks)
- c) Besides the amount of heat produced by the two flames, state other differences. (2mks)

27. a) Study the equation below and answer the questions that follow.

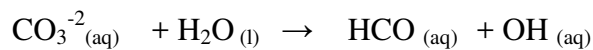

Which substance is an oxidizing agent? Give reasons. (2mks)

- b) Identify the reducing agent in the equation below

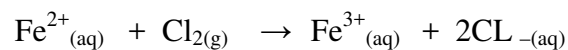

28. A candle was burnt using the apparatus shown below. The initial volume of measuring cylinder was 90cm^3 . The apparatus was allowed to cool and the volume of air in the measuring cylinder had dropped to 70cm^3 .

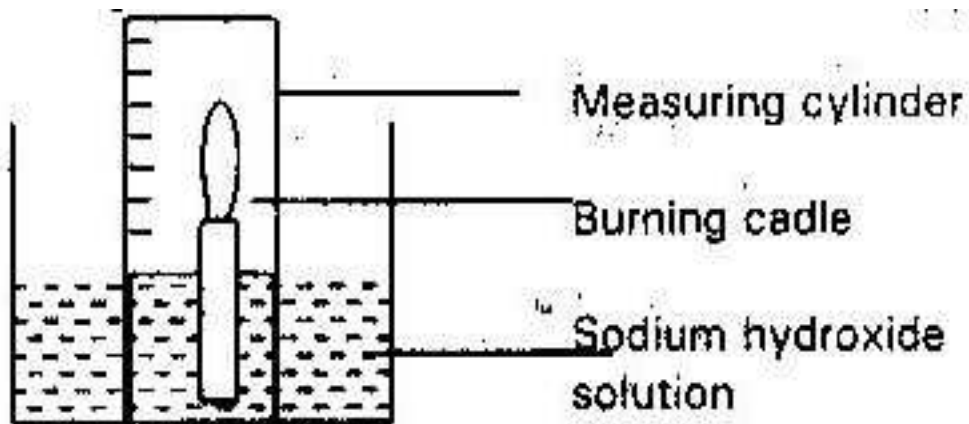

- a) Why was the volume recorded when the air was cooled? (1mk)
- b) What was the purpose of sodium Hydroxide? (1mk)
- c) Use the results given to calculate the percentage of oxygen in air. (2mks)
29. The graph below shows the changes that occur when a pure and an impure substance are heated.

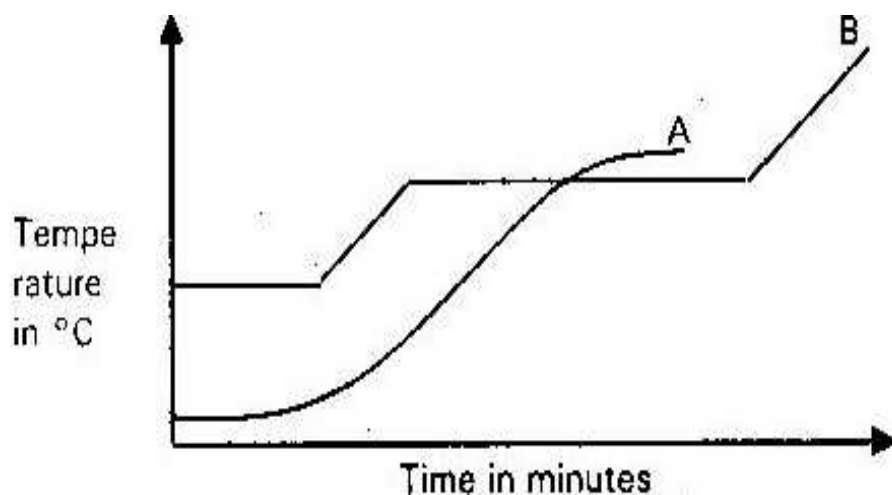

- a) Which curve represents pure substance? Explain. (2mks)
- b) Name one factor which affects the melting point of a solid and state effects. (2mks)

TOPIC 4

WATER AND HYDROGEN

1.

Use the information shown in the diagram below to answer the questions that follows.

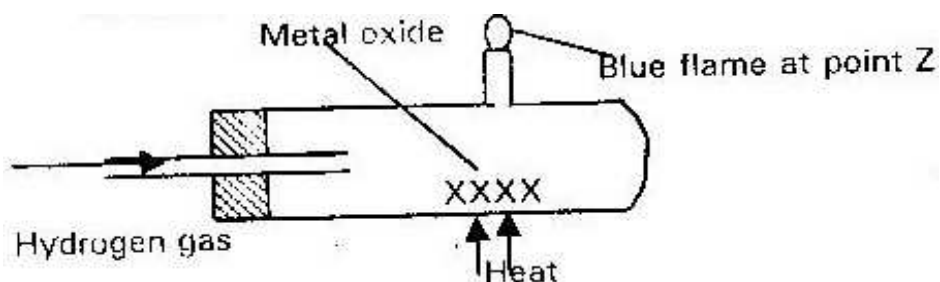

- i) Explain why it is important to pass the hydrogen gas for some time before lighting it at point Z. (1mk)
- ii) Write an equation for the reaction that takes place when hydrogen burns at point Z. (1mk)

2.

The order of reactivity of metal p, R and T starting with the most reactive is R.T.P. By using a tick (✓) to indicate no reaction, complete the table below to show what happens when the metals of each are added to solutions containing ions of metal P, R and T.

(3mks)

	Aqueous solution containing ions of metal		
Metal	P	R	T
P			
R			
T			

3.

In an experiment, soap solution was added to three separate samples of water.

The table below shows the volumes of soap solution required to form lather with 100cm^3 of each sample of water before and after boiling.

	Sample 1	Sample 2	Sample 3
Volume of soap before water is boiled in cm^3	27.0	3.0	10.6
Volume of soap after water is boiled in cm^3	27.0	3.0	3.0

- a) Which water sample is likely to be soft? Explain. (2mks)
- b) Explain the change in volume of soap solution used in sample III (1mk)

4.

Study the diagram below and answer questions that follow.

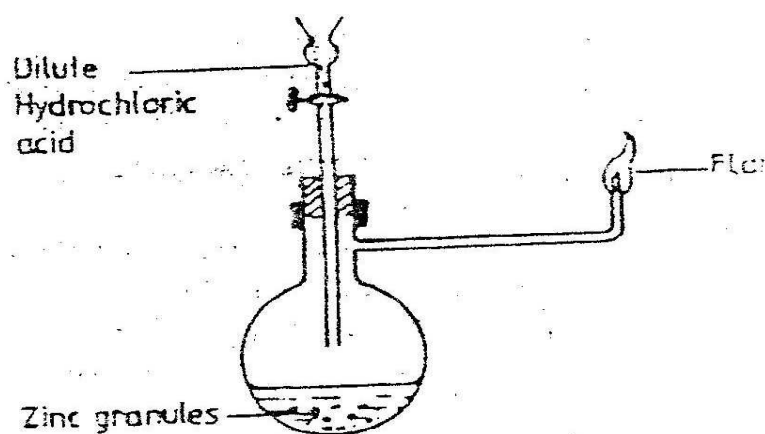

Write an equation for each of the two reactions that take place in the experiment represented by the diagram above (2mks)

5. Zinc metal and hydrochloric acid react according to the following:

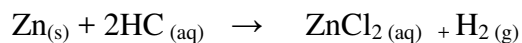

1.9 g of zinc metal was reacted with 100cm^3 of 0.2m Hydrochloric acid.

- a) Determine the reagent that was in excess. (2mks)
- b) Calculate the total volume of hydrogen gas that was liberated at S.T.P. (Zn= 65). Molar gas volume= 22.4dm^3 at STP. (1mk)
6. The diagram below represents set-up that was used to react lithium with water vapour. Study it and answer the questions that follow.

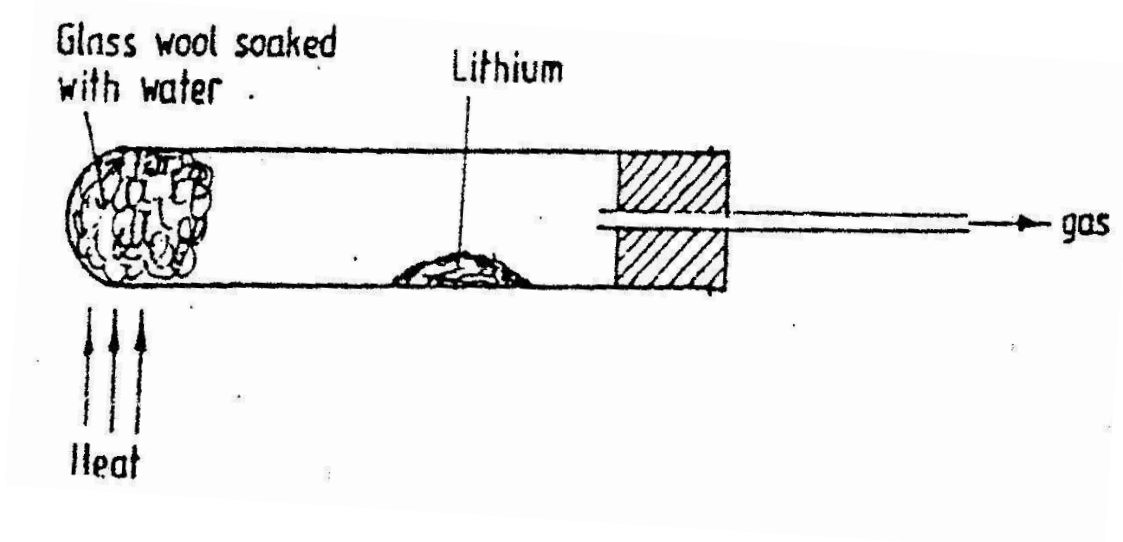

- a) Write an equation for the reaction that takes place given that the atomic number of Lithium is 3. (2mks)

- b) Why would it not be advisable to use potassium in place of Lithium in the above set up? (2mks)

7. A student set up the experiment below to collect gas K. The glass wool was heated before heating the zinc powder.

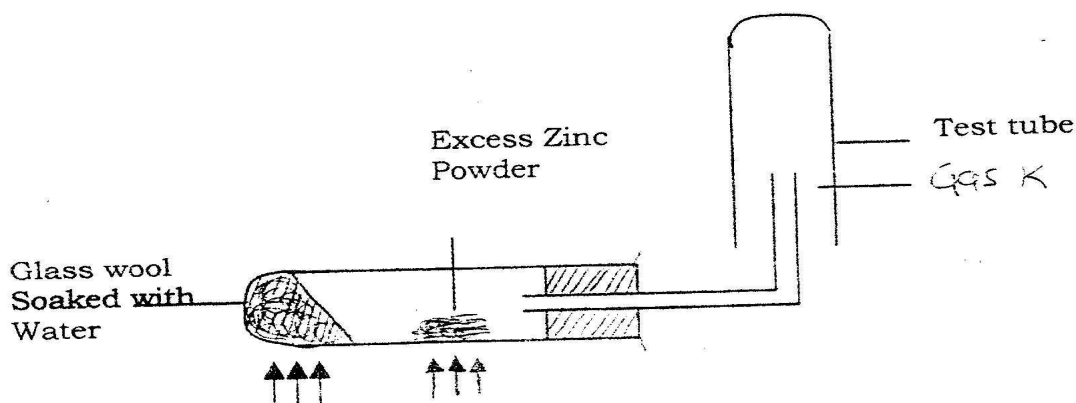

- a) Why was it necessary to heat the moist glass wool before heating zinc powder? (1mk)
- b) What would happen if the zinc powder was heated before heating the glass wool? (1mk)
- c) What property of gas K made it possible for it to be collected as shown in the diagram? (1mk)

8.

A sample of water drawn from a river passing through an agricultural district was divided into two portions. The first portion gave a white precipitate when acidified barium chloride was added. The second portion when warmed with aqueous sodium hydroxide gave a colourless gas which turned a moist red litmus paper to blue.

- a) Identify the ions present in the river water. (2mks)
- b) Suggest the possible sources of the ions identified in (a) above (2mks)

9.

The column below was used to soften hard water.

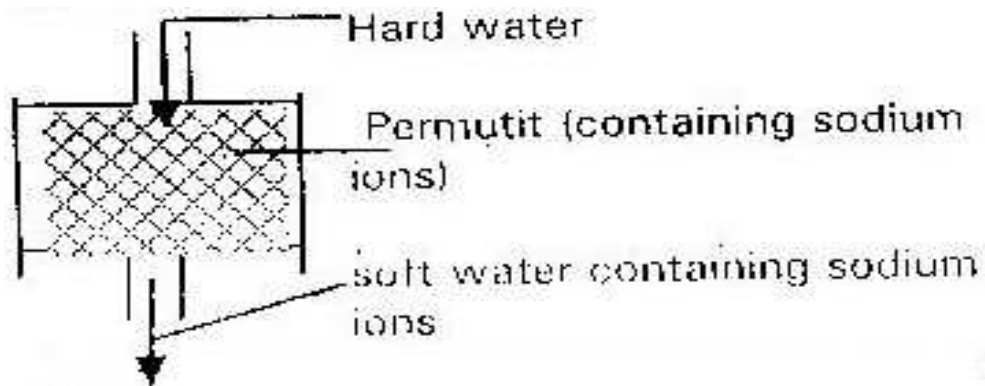

- a) Explain how the hard water was softened as it passed through column. (1mk)
- b) After sometime the material in the column is not able to soften hard water. How can the material be reactivated? (1mk)
- c) Give one advantage of using hard water for domestic purposes. (1mk)

10.

The table below shows the test carried out on separate samples of water drawn from a well and results obtained.

Tests		Results
I)	Addition of excess ammonia solution	White precipitate
II)	Addition of two drops of dilute sulphuric acid	No precipitate
III)	Addition of dilute hydrochloric acid followed by few drops of Barium chloride	White precipitate

a) Identify the cation and anion present in the water. (2mks)

b) Write an ionic equation for the reaction which takes place in test (III)

(1mk)

11.

Study the set up below and answer the question that follows.

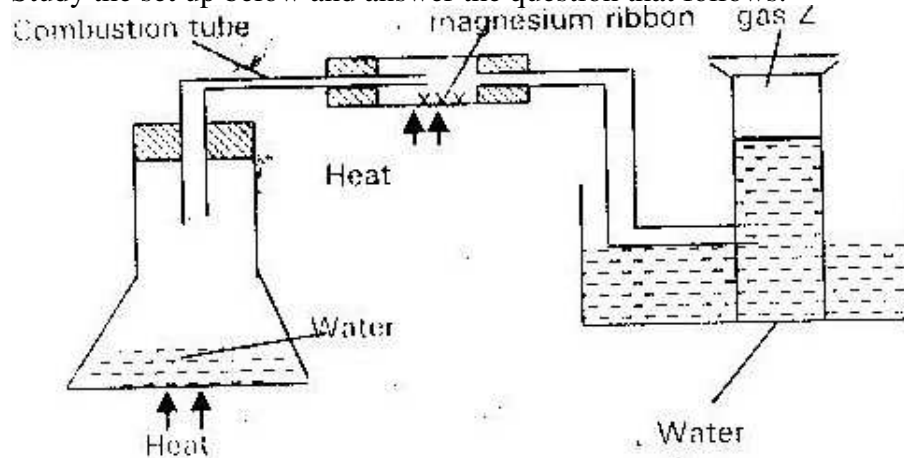

a) Write an equation for the reaction which takes place in the combustion tube. (1mk)

b) What property of gas Z allows it to be collected as shown in the diagram?

(2mks)

12.

10g of sodium hydrogen carbonate were dissolved in 20cm^3 of water in a boiling tube. Lemon juice was then added dropwise with shaking until there was no further observable change.

a) Explain the observation which was made in the boiling tube when the reaction was in progress. (2mks)

- b) What observation would have been made if the lemon juice had been added to copper turnings in a boiling tube? Give a reason. (1mk)
13. a) State one cause of temporary hardness in water. (1mk)
- b) How does distillation remove hardness in water? (3mks)

14.

Explain why hydrogen forms compounds in which its oxidation state is either + 1 or -1 (atomic number of H =1) (3mks)

15.

An atom of hydrogen can form two ions. Write two equations to show how a neutral atom of hydrogen can form the two ions. In each case show the sign of the energy changes. (2mks)

16.

When steam was passed over heated charcoal as shown in the diagram below hydrogen and carbon (II) oxide were formed.

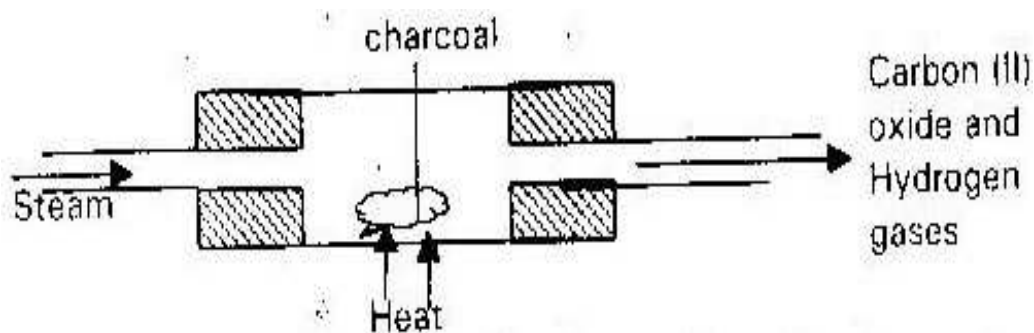

- a) Write the equation for the reaction which takes place. (1mk)
- b) Name two uses of carbon (II) Oxide gas which are also the uses of Hydrogen gas. (2mks)

17.

The table below shows the test carried out on a sample of water and the results obtained.

Tests		Results
i)	Addition of sodium Hydroxide	White precipitate which dissolves in excess
ii)	Addition of excess ammonia solution	Colourless solution obtained.
iii)	Addition of dilute Hydrochloric acid and barium chloride	White precipitate

- a) Identify the anions present in water. (1mk)
- b) Write an ionic equation for the reaction in (iii) (1mk)
- c) Write the formula of the complex ion formed in (ii) (1mk)

18.

The set up below used to demonstrate the effect of heat on hard water.

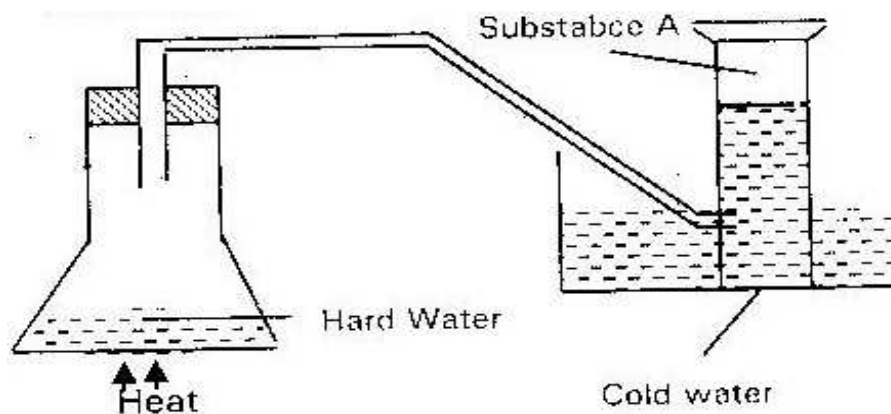

- a) Name substance, A (1mk)
- b) Explain why the heating of hard water produces substance A. (2mks)

19.

The diagram below shows a student's set up for the preparation and collection of hydrogen gas.

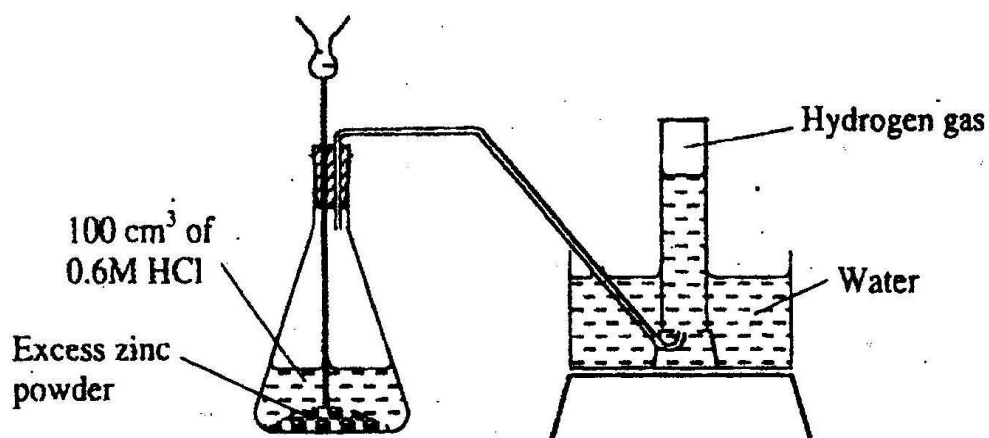

- a) How would the final volume of hydrogen gas produced be affected if 80cm³ of 0.7M hydrochloric acid was used? (1mk)
- b) Give a reason why helium is increasingly being preferred to hydrogen in weather balloons. (1mk)

20.

In a laboratory experiment hydrogen gas was passed over heated copper (II) oxide as shown in the diagram below.

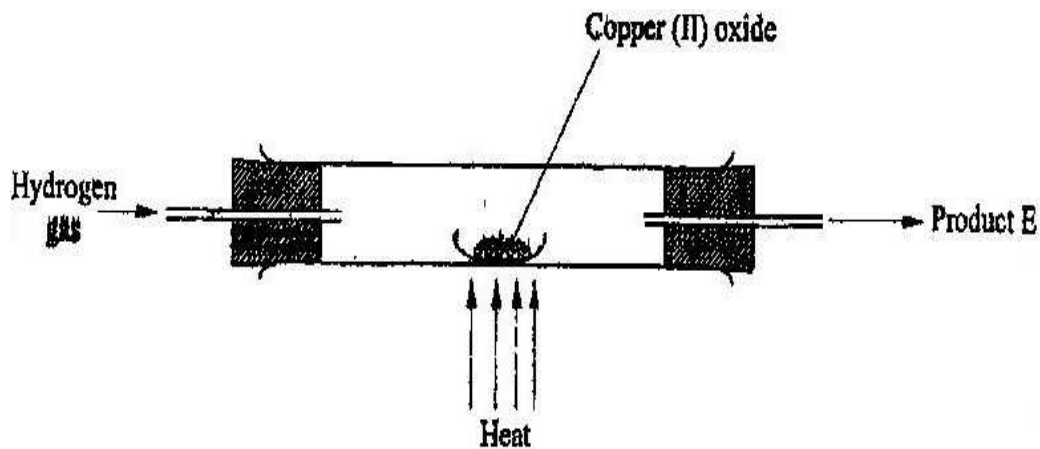

Describe a chemical test that can be used to identify the product E. (2mks)

21. a) A student was supplied with a colourless liquid suspected to be water.
- Describe one chemical test that could have been used to show that the liquid was pure water. (1mk)
 - How it could have been shown that the liquid was pure water. (1mk)
- b) The flow chart below shows the various stages of water treatment. Study it and answer the question that follows.

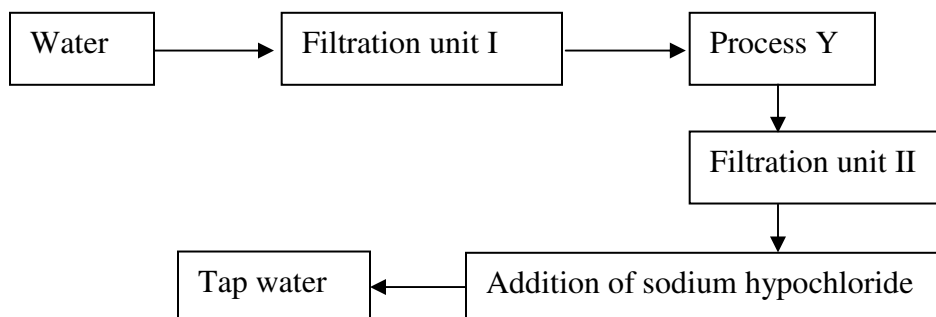

- i) Which substances are likely to be removed in filtration unit I? (1mk)
- ii) What is the name of process Y? (1mk)
- iii) What is the purpose of;
- a) Process Y
 - b) Addition of sodium hypochlorite? (1mk)
- iv) It was confirmed that magnesium sulphate was present in the tap water.
- a) What type of hardness was present in the tap water? (1mk)
 - b) Explain how this hardness can be removed. (2mks)

22.

The set up below was used to prepare hydrogen gas.

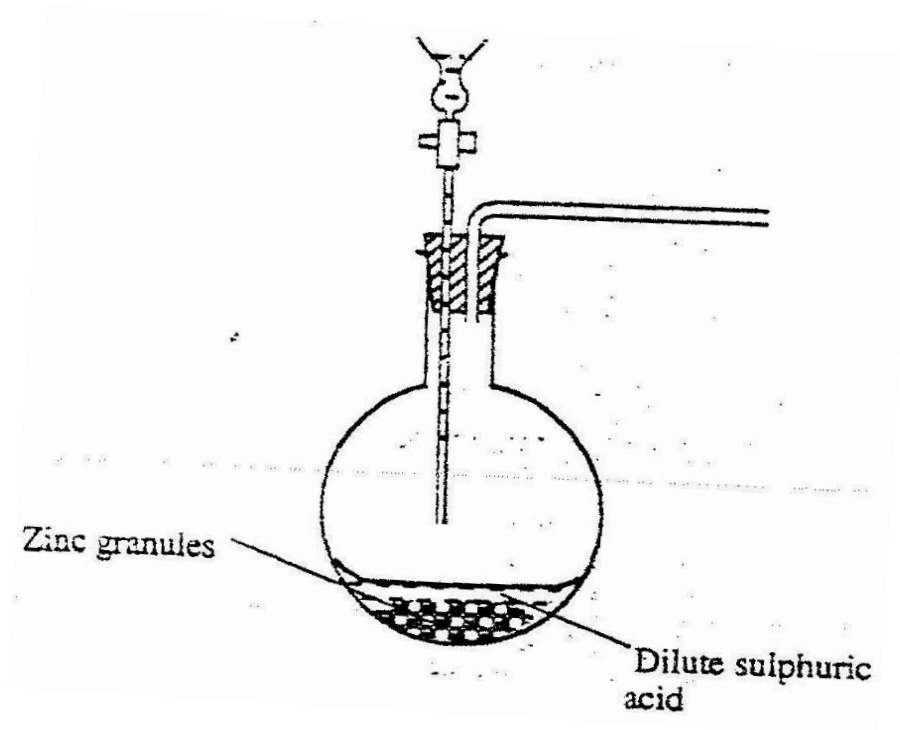

- a) Complete the diagram to show how a dry sample of hydrogen gas can be collected. (3mks)
- b) Write an equation which takes place when hydrogen gas burns in air. (1mk)
- c) 1.2 litres of hydrogen gas was produced at room temperature and pressure when 3.27g of zinc were used. Determine the relative atomic mass of zinc (molar gas volume is 24 litres). (4mks)
- d) State two industrial uses of hydrogen gas. (2mks)

23.

The set up was used to collect gas F, produced by the reaction between water and calcium metal.

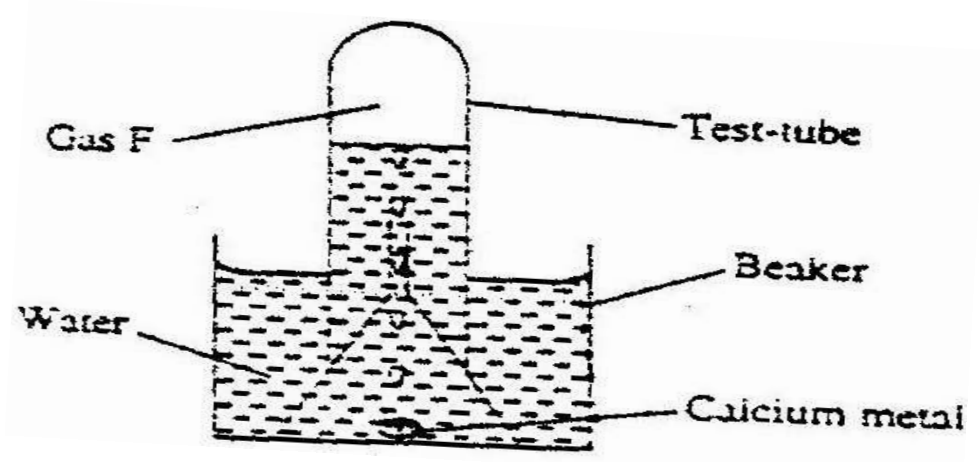

- i) Name gas F. (1mk)
- ii) At the end of the experiment, the solution in the beaker is a weak base. (2mks)
- iii) Give one laboratory use of the solution formed in the beaker. (1mk)

24. A piece of sodium was put into a beaker containing water.
- Write the equation for this reaction. (1mk)
 - State the observations made in the above reaction. (2mks)
25. When $\text{Na}_2\text{CO}_3 \cdot X\text{H}_2\text{O}$ is strongly heated, it loses 63.2% of its mass. Find the value of X. (2mks)
26. Study the diagram below and answer the questions that follows:

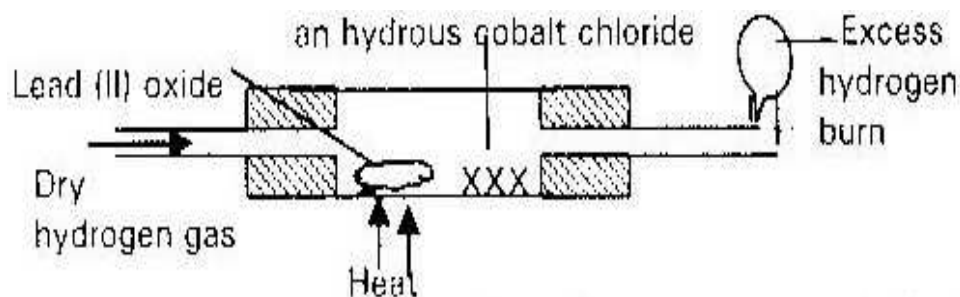

- State two observations that may be made in the combustion tube. (1mk)
 - Write an equation for the reaction of hydrogen with Lead (II) Oxide. (1mk)
27. The table below gives information on reactions of metals B, C, D and E.

Metal	Reaction with acid	Action of heat on its nitrate	Reaction with water
B	Hydrogen evolved	Oxide formed	No reaction
C	No reaction	Metal formed	NO reaction
D	Hydrogen evolved	Oxide formed	Hydrogen evolved
E	NO reaction	Oxide formed	NO reaction

Arrange the metals in the order of decreasing reactivity starting with the least reactive.

28. The diagram below shows how lithium reacts with steam.

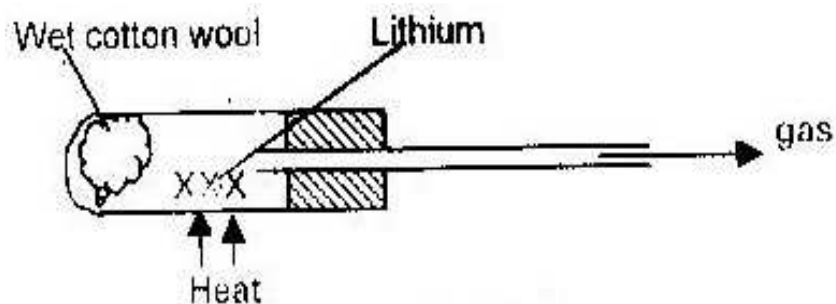

- i) Write an equation for the reaction. (1mk)
- ii) Why is it not advisable to use potassium in place of lithium? (1mk)
29. Steam reacts with iron fillings to form tri-iron tetra oxide.
- $$3\text{Fe}_{(s)} + 4\text{H}_2\text{O}_{(g)} \rightarrow \text{Fe}_3\text{O}_4_{(s)} + 4\text{H}_2_{(g)}$$
- a) State one experimental condition that will make the reaction reversible. (1mk)
- b) Give two commercial uses of Hydrogen gas. (2mks)
30. When a metal oxide of element "W" reacts with hydrogen, the equation for the reaction is:
- $$\text{WO}_3_{(s)} + 3\text{H}_2_{(g)} \rightarrow \text{W}_{(s)} + 3\text{H}_2\text{O}_{(l)}$$
- Comment on the reactivity of element "W" with hydrogen gas. (1mk)
31. The following observations were made during the investigation of the reaction of metal with water.
- When a piece of sodium metal was dropped in a bowl; of water, it reacted vigorously, darting over the surface of water. Hydrogen gas was liberated.

- Iron metal did not react with cold water but red hot iron reacted with steam liberating hydrogen and iron tetra oxide.
- Copper did not react with cold water but red hot iron reacted with steam liberating hydrogen and iron tetra oxide.
- Copper did not react with water or steam.

Answer the following questions

- a) Which metal is;
 - i) The most reactive? (1mk)
 - ii) The least reactive? (1mk)
 - b) i) What other product apart from hydrogen is formed in the reaction between sodium and water? (1mk)
 - ii) Write a chemical equation for the reaction in (b) above (1mk)
 - c) Comment on the PH of the resulting solution in (b) above. (1mk)
 - d) Name any other two elements which react in similar way to sodium (2mks)
 - e) Give the test for hydrogen gas. (1mk)
32. What is the differences between a deliquescent and hygroscopic substance? (2mks)
33. When trying to put off an oil fire, water is not used. Explain. (2mks)

FORM 2 WORK

TOPIC 1

STRUCTURE OF THE ATOM AND THE PERIODIC TABLE

1. Complete the table below. (1 ½ mks)

Isotope	Number of		
	Protons	Neutrons	Electons
59 <i>Co</i> 27			

2.

The electron arrangement of ions X^{3+} and Y^{2-} are 2:8 and 2:8:8 respectively.

- a) Write the electron arrangement of elements “X” and “Y” (2mks)
- b) Write the formula of the compound that would be formed between X and Y. (1mk)

3.

With reference to its atomic number of one explain why hydrogen can be placed in either group I or VII on the periodic table. (2mks)

4.

An element Y has the electronic configuration of 2:8:5

- a) Which period of the periodic table does the element belong. (1mk)

- b) Write the formula of the most stable anion formed when element Y ionizes. (1mk)
- c) Explain the difference between the atomic radius of element Y and ionic radius. (1mk)

5. 34

An ion of phosphorous can be presented as P^{-3}

15

Draw a diagram to show the distribution of the electrons and the composition in the nucleus of the ion of phosphorous. (2mks)

6.

The grid below shows part of the periodic table. The letters do not represent the actual symbols of the element.

					G				
					H			I	
F									

- a) Select
- i) Element which has the largest atomic radius (1mk)
- ii) Most reactive non- metal
- b) Show on the grid the position of element “J” which forms J^{2-} ions with electronic configuration 2:8:8:8 (1mk)

7. Study the information in the table below and answer questions that follows;

Ions	Electron arrangement	Ionic radius
Na ⁺	2,8	0.95
K ²⁺	2,8,8	0.133
Mg ²⁺	2,8	0.065

Explain why the ionic radius of

a) K⁺ is greater than that of Na⁺ (1mk)

b) Mg²⁺ is smaller than that of Na⁺ (2mks)

8.

An atom of hydrogen can form two ions. Write down two equations to show how the neutral atom of each case show the sign of the energy change involved.(2mks)

9.

Brass is an alloy of zinc and copper. Give one use of brass (1mk)

10.

Use the information in the table below to answer questions that follows. That follows. The letters do not represent the actual symbols of the elements.

Elements	B	C	D	E	F
Atomic numbers	18	5	3	5	20
Mass Numbers	40	10	7	11	40

a) Which two letters represent the same element? Give a reason (2mks)

b) Give the number of neutrons in an atom of element D (1mk)

11.

The table below gives some information about elements I, II, III and IV which are in the same group of the periodic table.

Use the information to answer the questions that follows.

Element	First ionization energy $\text{K} \ 5 \ \text{mol}^{-1}$	Atomic radius (nm)
I	520	0.15
II	500	0.19
III	420	0.23
IV	400	0.25

State and explain the relationship between the variation in the first ionization

energies and the atomic radii.

(3mks)

12.

The table below shows the relative atomic masses and the percentage abundance of the isotopes L_1 , L_2 of element L

	Relative atomic masses	% abundance
L_1	62.93	69.09
L_2	64.93	30.91

Calculate the relative atomic mass of element L.

(3mks)

13.

Explain why there is general increase in the first ionization energies of the elements in period 3 of the periodic table from left to right.

(2mks)

14.

The table below shows the number of valence electrons of the elements P, Q and R.

Element	P	Q	R
Number of valence electrons	3	5	2

- a) Explain why P and R would not be expected to form a compound. (1mk)
- b) Write an equation to show the effect of heat on the carbonate of R (1mk)
- c) Write the formula for the most stable ion of Q. (1mk)

15. a) What are isotopes? (1mk)

18

- b) Determine the number of neutrons in ^{18}O

8

(1mk)

16.

The grid below is part of the periodic table. Use it to answer the questions that follow. (The letters are not the actual symbols of the elements)

					R	S		
N	Q					T	U	
P								

- a) Indicate on the grid the position of an element represented by letter V whose atomic number is 14. (1mk)
- b) Select a letter which represents a monoatomic gas. (1mk)

c) Write an equation for the reaction between Q and T. (1mk)

17.

The table below gives elements represented by letters T, U, V, w, x, Y their atomic numbers.

Elements	T	U	V	W	X	Y
Atomic numbers	12	13	14	15	16	17
Electronic arrangement						

Use the information in the table to answer the questions below

- a) Complete the above table giving the electron arrangement of each of the element (2mks)
- b) In which period of the periodic table do these elements belong? Give a reason. (2mks)
- c) How does the atomic radius of V compare with that of X. Explain? (2mks)
- d) Give the formula of the compound that could be termed between “U” and “W” (1mk)
- e) What type of bonding will be present in a compound formed between T and Y? Explain (2mks)
- f) Arrange the species T^{2+} , T^+ and T in increasing order of size
- g) Which are the ions X^{+2} and X^{-2} is most suitable? Explain (2mks)
- h) Give the formula of
- i) An acidic oxide formed when one of the elements in the table is heated in air (1mk)

- ii) A basic oxide formed when one of the elements in the table is heated in the air. (1mk)

18. Study the table below and answer the questions that follows:-

Elements	Atomic numbers	Relative atomic mass	Melting point ⁰ C
Aluminium	13	27.0	1020
Calcium	20	40.0	850
Carbon	-	12.0	3730
Hydrogen	-	1.0	-249
Magnesium	12	24.3	650
Neon	10	-	-249
Phosphorus	15	31.0	442 white 590 red
Sodium	-	23	97.8

- a) Complete the table by filling in the missing atomic numbers and atomic masses (2mks)
- b) Write the electron arrangement for the following ions
- i) Ca^{2+} (1mk)
- ii) P^{-3} (1mk)
- c) What is the melting point of hydrogen in degrees Kelvin (1mk)
- d) Which of the two allotropes of phosphorous has a higher density? Explain (2mks)

- e) The mass numbers of the three isotopes of magnesium are 24, 25 and 26.
What is the mass number of the most abundant isotope of Magnesium?
Explain (2mks)
- f) Give the formula to the compound formed between aluminium and carbon. (1mk)

19

The grid given below represents part of the periodic table. Study it answer the questions that follows. The letters do not represent the actual symbols of the elements.

	C			B					
	F			D		E			

- i) What name is given to the group of elements to which “C” and “F” belong? (1mk)
- ii) Which letter represents the element that is least reactive? Explain. (2mks)
- iii) What type of bond is formed when B and E reacts? Explain. (2mks)
- iv) On the grid indicate with a tick the position of an element G which is in the third period of the periodic table and forms G^{-3} ion. (1mk)

20.

Study the information in the table below and answer the questions that follow.

The letters do not represent the actual symbols of the elements

Elements	Electronic configuration	Ionization energy kJ mol^{-1}
P	2,1	519
C	2,8,1	494
R	2,8,8,1	418

- i) What is the general name given to the group which elements P, C and R belongs? (1mk)
- ii) What is meant by ionization energy (2mks)
- iii) Explain why element p has the highest ionization energy. (2mks)
- iv) a) When a piece of element "C" is placed on water. It melts and hissing sound is produced as it moves on the surface of the water. Explain these observations (2mks)
- b) Distinguish between a strong and a weak base. Give an example of each. (2mks)
- c) Neutralization is one of the methods of preparing salt
- i) What is meant by neutralization (1mk)
- ii) Describe how you would prepare crystals of sodium nitrate starting with 200 cm^3 of 2m sodium hydroxide. (3mks)
- iii) Write an equation for the reaction that takes place when a solid sample of sodium nitrate is heated. (1mk)

21. a) The chart below is an outline of part of the periodic table

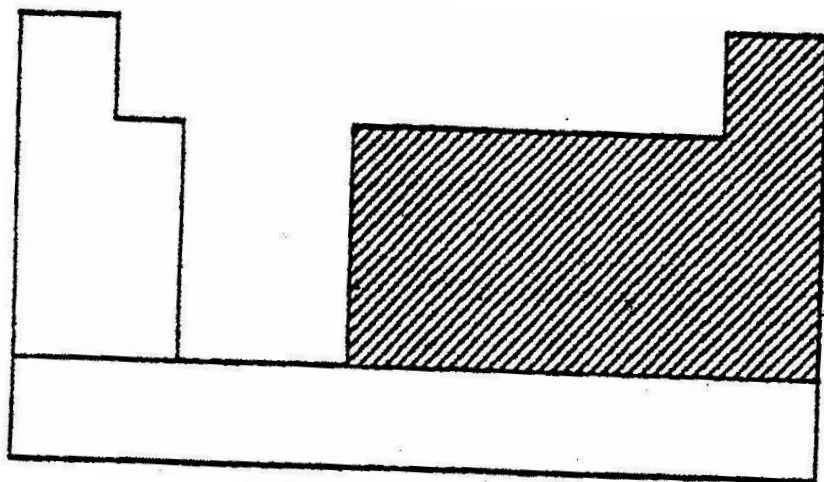

- i) With the help of vertical and horizontal lines, indicate the direction of increasing metallic nature of elements. (2mks)
- ii) Which type of elements are represented in the shaded area? (1mk)
- b) i) Element "A" is in the same group of the periodic table as chlorine. Write the formula of the compound formed when "A" react with potassium metal (1mk)
- ii) What type of bonding exists in the compound formed in b (i) above? Give a reason for your answer (3mks)
- c) Starting with aqueous magnesium sulphate, describe how you would obtain a sample of magnesium oxide. (3mks)
- d) Write two ionic equations to show that aluminium hydroxide is amphoteric (2mks)

22. Brine usually contain calcium and magnesium salts. Explain how sodium carbonate is used to purify brine. (2mks)

23. The table below gives information about elements A₁, A₂, A₃ and A₄

Element	Atomic number	Atomic radius (nm)	Ionic radius (nm)
A ₁	3	0.134	0.074
A ₂	5	0.090	0.12
A ₃	13	0.143	0.050
A ₄	17	0.099	0.181

i) In which period of the periodic table is element A₂

Give reason. (2mks)

ii) Explain why the atomic radius of:

I. A₁ is greater than that of A₂ (2mks)

II. A₄ is smaller than its ionic radius. (2mks)

iii) Select the element which is in the same group as A₃ (1mk)

iv) Using dots (•) and crosses (x) to represent outermost electrons, draw a

diagram to show the bonding in the compound formed when A₁ reacts

with A₄ (1mk)

24. Using the table below explain the following

Ions	Na ⁺	Mg ²⁺	Al ³⁺	K ⁺
Ionic radius	0.086	0.073	0.064	0.097

a) Ionic radius of Na⁺ is less than that of K⁺. Explain (1mk)

- b) Sodium, magnesium and aluminium belong to the same period in the periodic table. Explain the trend in their ionic radii. (3mks)

25. Study the information in the table below and Answer questions that follows.

W	X	Y	Z
Glows red hot when heated. Does not react with water but turns red brown on surface when left outside over night.	Forms a ball on the surface of water and react. Produce a hissing sound. Burning in air with a yellow orange flame.	Burns with dazzling fame and does not react with cold water.	Burns with a red flame and produce hydrogen with cold water.

- a) Identify the above metals (1 ½mks)
- b) Arrange the metals according to their reactivity starting with the most reactive. (1mk)

26. Element Z in the second period of the periodic table forms Z^{3+} ions using (x) to represent electrons; draw a complete structure of an isotope of “Z” having mass number 8. (3mks)

The table below gives information on the some elements. The letters are not actual symbols of the elements. Study it and it to answer the questions that follow.

Elements	Ionization energy (kJ)	Atomic radius (NM)	Ionic radius (NM)
L	410	0.154	0.091
G	380	0.192	0.097
Q	490	0.108	0.086

- a) Select the most reactive element and give reasons for your answer. (2mks)
- b) Do this element represent metallic or nonmetallic group. Explain. (2mks)
27. The table below shows part of periodic table for some elements represented by Q, R, T, V, W, X, Y and Z. The letters do not represent the actual symbols of the elements. Study it and answer the questions that follows.

T ₁								T ₁	2
Q ₃	4			5	W ₆	7	8	V ₉	10
R ₁₁	12			13	14	15	16	X ₁₇	Y ₁₈
19	20								

- a) i) Explain why element T has been placed in two positions in the periodic table. (1mk)
- ii) What is the name of the chemical family to which q and R belong?
- iii) Elements Y is generally unreactive. Explain (1mk)
- b) i) Explain the difference in atomic radius of atoms of elements X and Y. (1mk)
- ii) V is more reactive than W Explain (1mk)
- c) i) Draw cross (x) and dots (.) diagram to show bonding between “W” and “T” to form compound WT₄ (2mks)

- ii) Explain why WT_4 have low melting point and does not dissolve in water (2mks)
- d) Element X consist of two isotopes whose mass numbers are 35 and 37 exist in the ratio of 3:1 respectively.
- i) Draw the atomic structure of the isotope whose mass number is 35 and atomic number 17. (2mks)
- ii) Determine the relative atomic mass of element X (2mks)
28. a) What is an isotope?
- b) Determine the relative atomic mass of argon whose isotope mixture is
36. Ar (0.34%) 38Ar (0.06%) 40 Ar (99.6%)
- 18 18 18
29. An element “z” has a mass number of 33 and has 18 neutrons
- a) What is the atomic number of element Z? (1mk)
- b) Write an equation to show how atom of “z” forms an ion. (1mk)
30. Study the flow chart below and answer the questions that follows:-

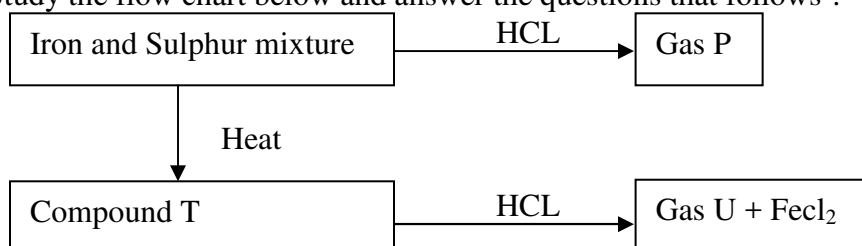

- a) Name
- i) Gas P (1mk)
 - ii) Compound T (1mk)
 - iii) Gas U (1mk)
- b) Give the chemical test that you would use to identify
- i) Gas P (1mk)
 - ii) Gas U (1mk)
31. Element E has atomic numbers 15
- a) Write the electronic arrangement for an atom of “E” (1mk)
 - b) Explain why “E” forms a chloride which is a liquid of low boiling point.
(2mks)
32. An element “H” consist of isotopes of mass “10” and “11” with a percentage composition of 18.7% and 81.3% respectively. Determine the RAM of H. (2mks)

TOPIC 2

CHEMICAL FAMILIES.

1.

The table below gives the atomic numbers of elements W X Y and Z. The letters do not represent the actual symbols of the elements.

Element	W	X	Y	Z
Atomic numbers	9	10	11	12

a) Which one of the elements is less reactive? Explain. (2mks)

b) i) Which two elements would react most vigorously with each other

ii) Give the formula of the compound formed when elements in b (i)

above react (1mk)

2.

The table below gives the energy required to remove the outer most electrons from same group

Elements	I	II	III	IV
Energy kj /Mole	494	418	519	376

Arrange the elements in the order of their reactivity starting with the most reactive. (2mks)

3.

The information below relates to elements s, T, U, and x. The letters do not represent the actual symbols of the elements.

i) "T" displaces "X" from aqueous solution containing ions of "X"

- ii) Hydrogen gases reduces heated oxide of “s” but does not reduce the heated oxide of “X”\
- iii) “U” liberates hydrogen gas from cold water but “T” does not
- a) Write an equation for the reaction between “T” and ions of “X”
both T and X are in the group II of the periodic table (1mk)
- b) Arrange the elements in order of their increasing reactivity (1mk)

4.

The electronic structures for elements represented by letters A, B, C, and D are:-

A= 2, 8, 6 B= 2, 8, 2 C= 2, 8, 1 D= 2, 8, 8

- a) Select the element which forms
- i) Double charged cation (1mk)
- ii) A soluble carbonate (1mk)
- b) Which element has the smallest atomic radius (1mk)

5.

The information in the table below relates to elements in the same group of the periodic table. Study it and answer the questions that follows:-

Elements	Atomic size (mm)
G1	0.19
G2	0.23
G3	0.15

Which element has highest ionization energy? Give a reason. (3mks)

6. The oxides of elements “A” and “B” have the properties shown in the table below. The letters do not represent actual symbols of the elements.

A	B
A gas at room temperature	Solid normal temperature
Dissolves in water to form acidic solution	Dissolves in water to form alkaline solution

Give one example of element “A” and “B” (2mks)

7.

An oxide of F has the formula F_2O_5

- Determine the oxidation state of “F” (1mk)
- In which group of the periodic table is element “F” (1mk)

8.

Yellow phosphorus reacts with chlorine gas to form a yellow liquid. The liquid fumes when exposed to air. Explain these observations. (2mks)

9. 2003

Explain why the reactivity of group (VII) elements decreases down the group. (3mks)

10.

The atomic numbers of element “C” and “D” are 19 and 9 respectively. State and explain the electro conductivity of compound CD in:-

- Solid state (1 ½ mark)
- Aqueous state (1 ½ mark)

11.

- Explain why the metals magnesium and aluminium are good conductors of electricity. (1mk)

- b) Other than cost, give two reasons why aluminium is used for making electric cables while magnesium is not. (2mks)

12.

The table below gives information on four elements represented by letters K, L, M and N. Study it and answer the questions that follow. The letters do not represent the actual symbols of the elements.

Elements	Electron arrangement	Atomic radius (nm)	Ionic radius
K	2,8,2	0.136	0.065
L	2,8,7	0.099	0.181
M	2,8,8,1	0.099	0.181
N	2,8,8,2	0.174	0.099

- a) Which two elements have similar chemical properties? Explain (2mks)
- b) What is the most likely formula of the oxide of "L" (1mk)
- c) Which element is a non-metal? Explain (2mks)
- d) Which one of the elements is the strongest reducing agent? Explain(2mks)
- e) Explain why the ionic radius of "N" is less than that of "M" (2mks)
- f) Explain why the ionic radius of "L" is larger than its atomic radius.(2mks)

13.

Study the information given in the table below and answer the questions that follow. The letters do not represent the actual symbols of elements.

Elements	Atomic numbers	Boiling point
S	3	1603
T	13	2743
U	16	718
V	18	87
W	19	1047

- a) Select the element which belong to the same
- i) Group (1mk)
 - ii) Period (1mk)
- b) Which element
- i) is in gaseous state at room temperature? Explain (2mks)
Take room temperature to be 298K
 - ii) Does not form oxides (1mk)
- c) Write the:-
- i) Formula of the nitrate of element T (1mk)
 - ii) Equation for the reaction between element “S” and “U” (1mk)
- d) What type of bond would exist in the compound formed when element “U” and “T” react? Give a reason for your answer (2mks)
- e) The aqueous sulphate of element “w” was electrolyzed using inert electrodes. Name the products formed at the

- i) Cathode (1mk)
- ii) Anode (1mk)

14. The table below shows some properties of chlorine, bromine and iodine.

Elements	Formulae	Colour and state at room temperature	Solubility in water
Chlorine	Cl ₂	(i).....	Soluble
Bromine	Br ₂	Brown liquid	(ii).....
Iodine	I ₂	(iii)	Slightly soluble

- a) Complete the table below by giving the missing information in (i) (ii) (3mks)
- b) Chloride is prepared by reacting concentrated hydrochloric acid with Manganese (IV) oxide.
- i) Write the equation for the reaction between concentrated hydrochloric acid and manganese (IV) oxide.
- ii) What is the role of manganese (IV) oxide in this reaction (1mk)
- c) i) Iron (II) chloride reacts with chlorine gas to form substance "E". Identify substance "E" (1mk)
- ii) During the reaction in c (i) above, 6.30g of iron (II) chloride were converted to 8.06g of substance "E". Calculate the volume of chlorine gas used. (Cl=35.5) molar gas at room temperature = 24000 cm³ (Fe= 56) (3mks)
- d) Draw and name the structure of the compound formed when excess chlorine gas is reacted with ethane gas. (2mks)
- Structure.....

Name

15. The grid below represents part of the periodic table. Study it and answer the questions that follows:- The letter given do not represent the actual symbols of the elements.

					A		
	B		C		D		E
F	G						
							H

- i) Select the element that can form an ion with a change of-2. Explain your answer. (2mks)
- ii) What type of structure would the oxide of C have? Explain your answer. (2mks)
- iii) How does reaction of H compare with that of E? (2mks)
- iv) 1.3g of “B” react completely when heated with 1.21 litres of Cl₂ (g) at STP. (1 mole of gas of STP occupies 22.4 litres)
 - I) Write a balanced equation for the reaction between B and Cl₂(1mk)
 - Ii) Determine the relative atomic mass of B. (2mks)
- v) Explain how you would expect the following to compare.
 - a) Atomic radii of “F” and “G” (1mk)
 - b) The pH values of aqueous solution of oxides of B and D. (2mks)
- vi) The table below shows some physical properties of some substances. Use the information in the table to answer the questions that follow:-

				Electrical conductivity
Substances	Melting	Boiling point ⁰ C	Solid	Solid
U	1083	2595	Good	Good
V	801	1413	Poor	Good
W	5.5	80.1	Poor	Poor
X	-114.8	-84.9	Poor	Poor
Y	3550	4827	Poor	poor

i) Which substance is likely to be (1mk)

(I) A metal (1mk)

(II) Liquid at room temperature (1mk)

ii) Which substance is likely to have the following structures?

(I) Simple molecular (1mk)

(II) Giant atomic (1mk)

16. Lithium, sodium and potassium belong to the same group of the periodic table

i) Arrange the elements in the order of increasing ionization energy. (1mk)

ii) Explain the trend in 2(i) above (2mks)

17. When heated in a current of Nitrogen gas, magnesium reacts to form a compound magnesium nitride, Mg₃N₂

a) Calculate a volume of Nitrogen at s.t.p required to react with 8g of magnesium (Mg= 24) molar gas volume at s.t.p= 22.4 dm³ (3mks)

b) Magnesium Nitride reacts with water to form magnesium hydroxide and ammonia. Calculate the volume of ammonia produced at S.T.P, if all magnesium nitride formed reacts completely with water. (3mks)

18. A student at Loreto Secondary school used 2g of calcium to prepare hydrogen gas in the laboratory. He used the set up below.

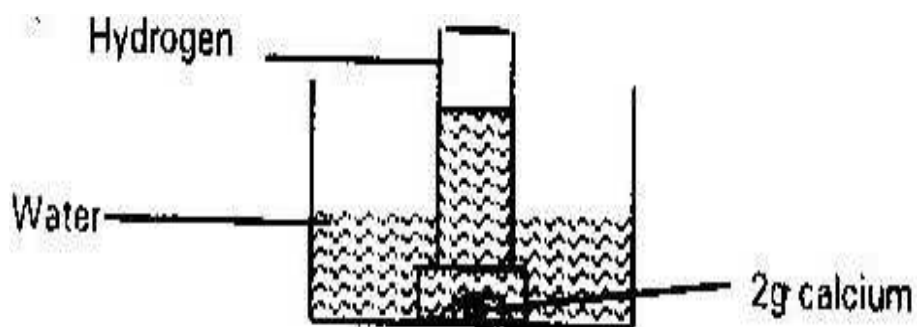

- Write a chemical equation for the reaction that produced hydrogen (1mk)
- Calculate the volume of hydrogen produced at room temperature (molar gas volume = $24,000\text{cm}^3$) (2mks)
- Explain why the same method cannot be used to prepare hydrogen using sodium in the laboratory (2mks)
- Explain why the same method cannot be used to prepare hydrogen using sodium in laboratory (2mks)
- Calculate the mass of the products formed if all the hydrogen produced in this experiment was burnt in excess air. (3mks)
- Explain how calcium is able to conduct electricity (2mks)

19. The table below gives atomic and mass numbers of some elements represented by letters “T” to “Y”. The letters are not actual symbols of elements. Use it to answer questions that follows:-

Elements	T	U	V	W	X	Y
Atomic numbers	1	18	1	19	20	17
Mass numbers	2	39	1	39	40	35

- a) Which element has the lowest ionization energy? (2mks)
- b) Element “V” is uniquely positioned in the periodic table. It has a tendency of forming compounds by either gaining or sharing electrons. Give the formula of a compound of “V” that is formed when V gain an electron. (1mk)
20. When magnesium metal burn metal burn in air. It reacts with both oxygen and Nitrogen gases giving a white ash- like substances. Write two equations for the two reactions that take place. (2mks)
21. Chlorine and iodine are elements in the same group in the periodic table. Chlorine gas is yellow while iodine solution is brown.
- a) What observations would be made if chlorine gas is bubbled through aqueous sodium iodide? Explain using an ionic equation. (1mk)
- b) Under certain conditions chlorine and iodine react to give iodine trichloride ($\text{ICl}_3(\text{s})$). What type of bonding would you expect to exist in iodine trichloride? Explain. (1mk)

22. It is not appropriate to refer to group VIII elements as “inert gases” Explain giving an example. (2mks)
23. What observations will you make when chlorine gas is bubbled through
- i) Potassium bromide (1mk)
 - ii) Potassium chloride (1mk)
 - iii) Explain these observations (3mks)
24. Explain why the reactivity of group (VIII) elements decreases down the group. (3mks)

TOPIC 3

STRUCTURES AND BONDING

1. When electric current is passed through two molten substances “M” and “N” in different containers. The observation in the table below were made.

Molten “M”	Conduct electricity current and is not decomposed.
Molten “N”	Conduct electric current and gas is formed at one of the electrodes.

Suggest the type of bonding present in substances “M” and “N” (2mks)

- 2.
- a) Using dot (.) and crosses (x) to represent electrons draw diagrams to represent the bonding in NH_3 and NH_4 (1mk)
- b) State why Ammonia molecule NH_3 can combine with H to form NH_4
(Atomic numbers: N= 7 and H= 1)

- 3.
- Explain why aluminium chloride is fairly soluble in organic solvents while anhydrous magnesium chloride is insoluble (2mks)

- 4.
- Using (•) crosses (x) to represents electrons. Draw diagrams to show bonding in CO_2 and H_3O^+ (atomic numbers) (H=1, C=6, O=8) (2mks)

5.

The table below shows some properties of substances C, D and E. Study it and answer the questions that follows:

Elements	M.P ⁰ C	Solubility in water	Electrical conductivity	
			Solid	Molten
C	-39	Insoluble	Good	Good
D	1610	Insoluble	Poor	Poor
E	801	Soluble	Poor	good

Select a substance

(a) With a giant molecular structure (1mk)

(b) That is not likely to be an element (1mk)

6.

Diamond and graphite are allotropes of carbon in terms of structures and bonding.

Explain the following

(a) Diamond is used to drill through hard rock. (1mk)

(b) Graphite is used as a lubricant (1mk)

7.

A hydrocarbon slowly decolourises bromine gas in presence of sunlight but does not decolourise acidified potassium manganate (VII). Name and draw the structural formula of the fourth member of the series to which the hydrocarbon

belongs (2mks)

8.

What type of bond is formed when lithium and fluorine react?

Atomic number (Li= 3 F = 9) Explain (2mks)

9.

When solid magnesium carbonate was added to solution of hydrogen chloride in methyl benzene, there was no apparent reaction on addition of water to the resulting solution/ mixture, there was vigorous effervescence. Explain these observations (2mks)

10.

Compound "Q" is a solid with a giant ionic structure. What forms would the compound conduct an electric current? Explain (2mks)

11.

The melting point of phosphorous trichloride is 90°C while that of magnesium chloride is 715°C in terms of structures and bonding. Explain the differences in their melting points. (3mks)

12.

Name one property of neon that makes it possible to be used in electric lamps. (1mk)

13.

With reference to iodine distinguish between covalent bonds and van der waals forces. (2mks)

14.

The table below gives some information about electrical conductivity and likely bonding in substances N, P and Q. Complete the table by inserting the missing information in spaces numbered I, II, and III (3mks)

Substances	Likely type of bonding	Electric conductivity	
		Molten	Solid
N	Metallic	I	Conduct
P	II	Does not conduct	Conduct
Q	III	Do not conduct	Does not conduct

15.

- a) What is meant by heat of vaporization? (1mk)
- b) The boiling points of ethanol, propanal and butanol are 78°C , 97.2°C and 117°C . Explain this trend. (1mk)

16.

Use dot (.) and crosses (x) to represent electrons, show bonding in the compounds formed when the following elements reacts (Si= 4, Na = 11, Cl = 17)

- a) Sodium and chlorine (1mk)
- b) Silicon and chlorine (1mk)

17.

In terms of structures and bonding explain why graphite is used as a lubricant (2mks)

18. a) Distinguish between a covalent bond and a co-ordinate bond. (2mks)
- b) Draw a diagram to show bonding in ammonium ion.
(N=7) (H=1) (NH_4^+) (1mk)

19. Explain why the boiling point of ethanol is higher than that of hexane. Relative molecular mass of ethanol is 46 while that of hexane is 86.

20. Both chlorine and iodine are halogens

- a) What are halogens? (1mk)
- b) In terms of structure and bonding. Explain why the boiling point of chlorine is lower than of iodine. (2mks)

21. The diagram below is a section of a model of the structure of element T.

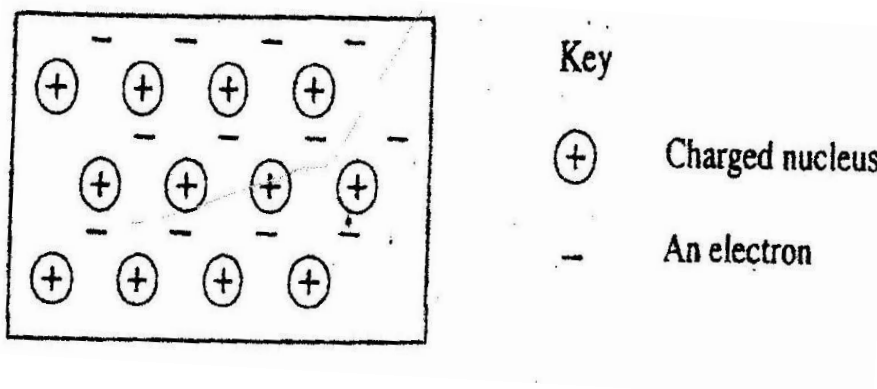

- a) State the type of bonding that exists in T. (1mk)
- b) In which group of the periodic table does element T belong? Give reason. (2mks)

22.

The table below gives atomic numbers of elements represented by the letters A, B, C and D

Element	A	B	C	D
Atomic number	15	16	17	20

Use the information to answer the questions that follow.

- a) Name the type of bonding that exists in the compound formed when A and D react. (1mk)
- b) Select the letter which represents the best oxidizing agent. Give a reason for your answer. (2mks)

23.

Study the information to answer the questions that follow. The letters do not represent the actual symbols of the elements.

Elements	Atomic number	Melting point ($^{\circ}\text{C}$)
L	11	97.8
M	13	660
N	14	1410
C	17	-101
R	19	63.7

- a) Write the electron arrangement for the ions formed by elements “M” and “C” (2mks)
- b) Select an element which is
- i) The most reactive non-metal (1mk)

- ii) A poor conductor of electricity (1mk)
- c) In which period of the periodic table does element “R” belongs? (1mk)
- d) Element R loses its outermost electrons more readily than “L”. Explain (2mks)
- e) Using dots and crosses to represent electrons, show bonding in the compound formed between N and Ca.

24.

The following diagrams show the structures of two allotropes of carbon. Study them and answer the questions that follow:-

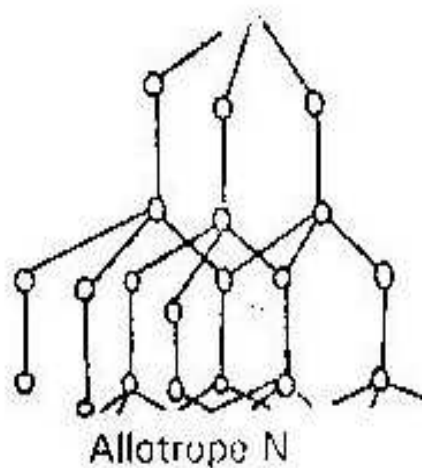
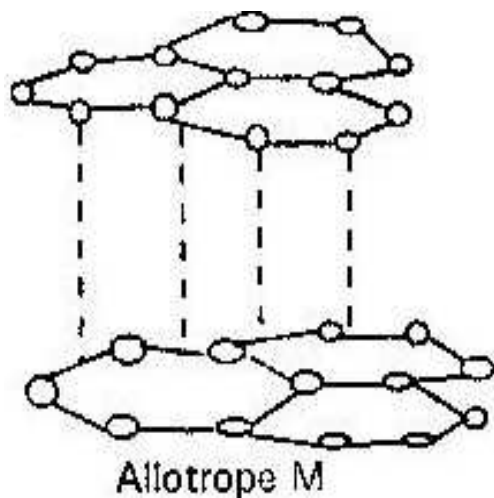

- i) Name the allotrope
 - M (1mk)
 - N (1mk)
- ii) Give one use of N (1mk)

- iii) Which allotrope conducts electricity? Explain (2mks)
25. a) The diagram below represents part of the structure of a sodium chloride crystal. The position of one of the sodium ions in the crystal is shown as

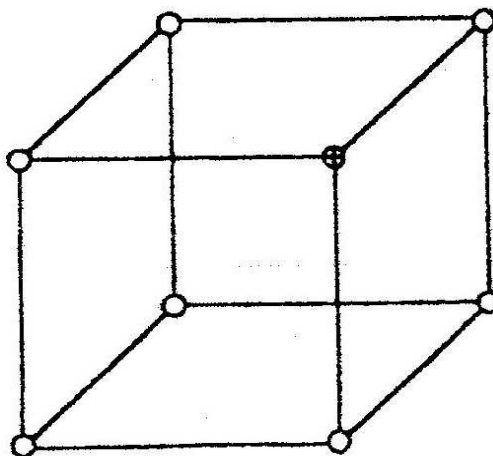

- i) On the diagram, mark the positions of the other three sodium ions (2mks)
- ii) The melting and boiling points of sodium chloride are 801°C and 1423°C respectively. Explain why sodium chloride does not conduct electricity at 25°C and 1413°C . (2mks)
- b) Give a reason why ammonia gas is highly soluble in water. (2mks)
- c) The structure of an ammonium ion is shown below.

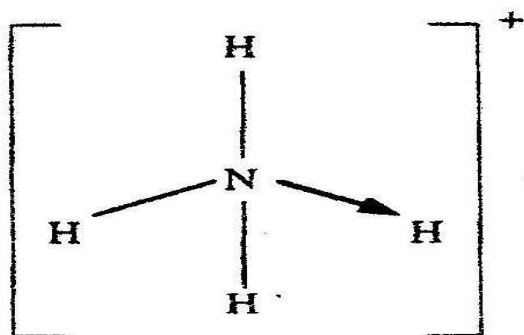

Name the type of bond represented in the diagram by N H (1mk)

26. Hydrogen reacts with iodine according to the equation give below.

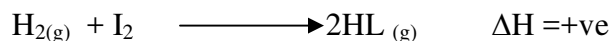

- In terms of bond energy explain why ΔH is positive. (2mks)
27. The molecular mass of hydrogen sulphide is 34 while that of water is “18”.
Explain why the boiling of water is higher than that of hydrogen sulphide. (2mks)
28. Using dots (.) and crosses(x) to represent electrons. Draw a diagram to show bonding in carbon (II) oxide. (C= 6, O = 8) (2mks)
29. Explain what happens when atoms are bonded together by
- Ionic bond (1mk)
 - Covalent bond (1mk)
30. Explain the following statements
- Solid sodium conducts electricity but is not electrolyte (1mk)
 - Solid iodine does not conduct electricity. (1mk)
 - Solid sodium iodide has a giant ionic structure but does not conduct electricity whereas liquid sodium iodide and aqueous solution of sodium iodide are both electrolytes. (2mks)
31. A certain substance has a boiling point of 1680°C . It does not conduct electricity when in solid form but conducts when molten. What is the most likely structure of the substance? Explain. (2mks)

32. Study the table below and answer the questions that follows:-

Substance	Formula	Molar heat of vaporization kj/mole	Melting points
Carbon disulphide	CS ₂	27.2	-111
Calcium chloride	CaCl ₂	149	782
Ethanol	C ₂ H ₅ OH	43.5	-117

- a) Which of the substance above have crystalline structure? Explain. (2mks)
- b) What is the best term to describe the structure of ethanol (1mk)
- c) Why is molar heat of vaporization of ethanol greater than that of carbon disulphide? (2mks)

33. Study the table below and answer the questions that follows.

Substances	Mp ⁰ c	BP ⁰ C	Electrical conductivity	
			Solid	Liquid
U	1083	2595	Good	Good
X	801	1413	Poor	Good
W	5.0	80	Poor	Good
V	-115	-84	Poor	Good
Y	355	4827	Poor	Good

- a) Which substances is likely to be
- i) A metal. Explain (2mks)
- ii) A liquid at room temperature (1mk)
- b) Which substance is likely to have following structure?
- i) Simple molecular (1mk)
- ii) Giant atomic structure (1mk)

34. Explain why at room temperature hexane is a liquid while methane is a gas. (2mks)

35. Study the table below and answer the questions that follows.

Substance	A change heat in air	Melting point ⁰ C	Thermal conductivity
E	Unreactive	High	Poor
F	Reactive	High	Poor
G	Unreactive	High	Good
H	Unreactive	Low	Good

Select the substance that would be most suitable.

a) For making a cooking pot (1mk)

b) A thermal insulator (1mk)

TOPIC 4

SALTS

1. Study the solubility curves below and answer the questions that follows-

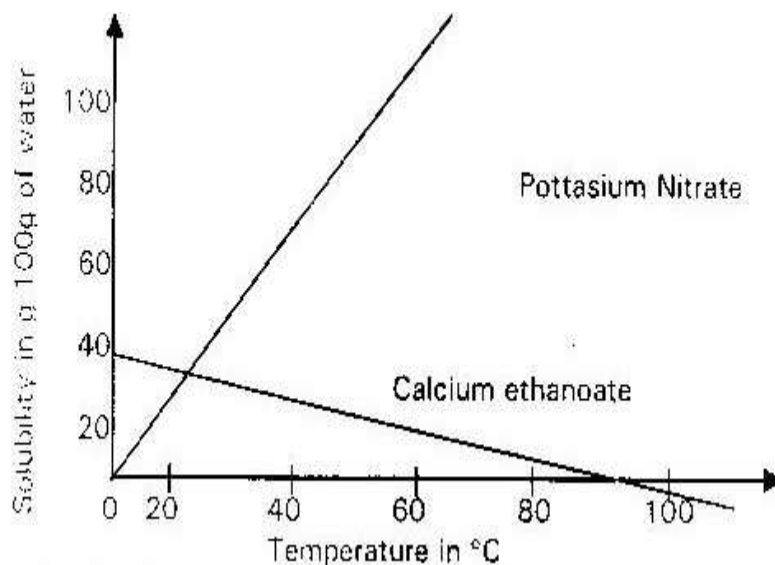

- a) At what temperature would equal amounts of potassium nitrate and calcium ethanoate dissolve in 100g of water? (1mk)
- b) Explain how you would prepare a saturated solution containing 80g of potassium nitrate in distilled water (1mk)
- c) A student added 30g of calcium ethanoate to 100g of boiling water and noticed that not all of it dissolved. Explain what would happen if the student cools the mixture with stirring up a temperature of 10°C. (1mk)

2.

The table below shows how solubility of some substances in water varies with temperature.

Substances	Change in solubility with temp in 100g			
	0 ⁰ C	20 ⁰ C	40 ⁰ C	60 ⁰
W	0.334	0.16	0.97	0.0058
X	27.60	34.0	40.0	45.5
Y	35.70	36.0	36.0	37.3

Which of the above substances is likely to be a gas?

3.

Describe how the following reagents can be used to prepare lead sulphate, solid potassium sulphate, solid lead carbonate, and dilute nitric acid distilled water.

(2mks)

4.

Study the information in the table and answer the question that follows:

Substances	Solubility g/100g water
A	1.26×10^{-2}
B	1.0×10^{-2}

Describe how a solid sample of substance A could be obtained from a solid mixture of A and B.

(2mks)

5. Study the chart below and answer the questions that follows:

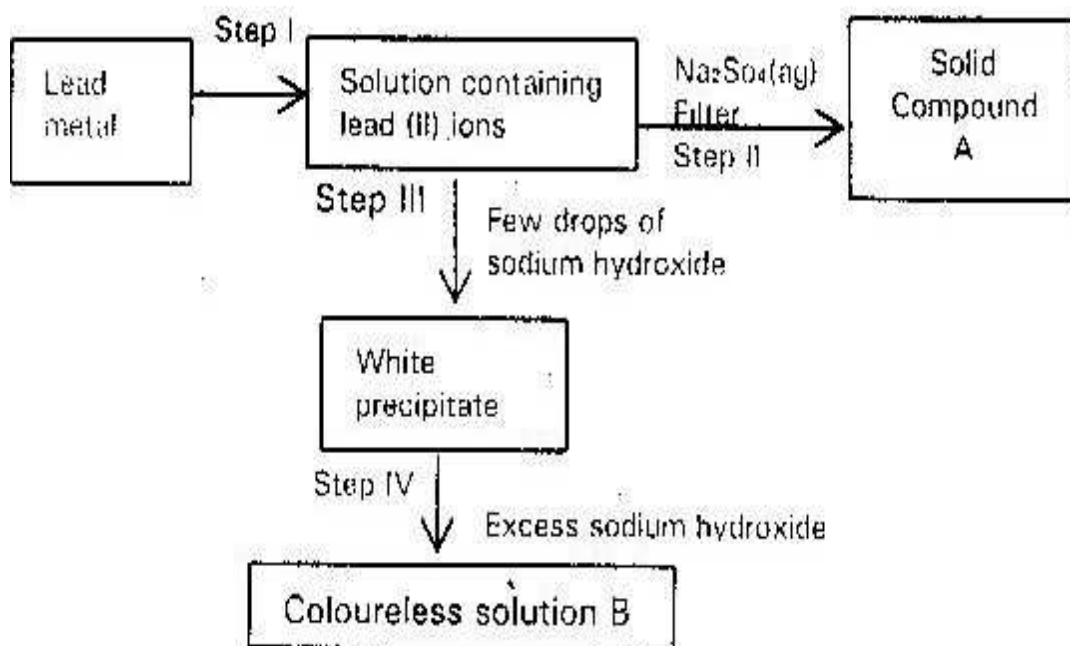

- a) Name reagent used in
- Step 1 (1mk)
 - Name compound a (1mk)
- b) Write an ionic equation for the reaction in the step (IV) (1mk)
6. The table below shows the solubility of a salt at various temperatures.

Temperature ⁰ C	Solubility
0	36
40	30
80	25
110	25

What would happen if a sample of saturated solution of salt at 40°C is heated to 80°C ? Explain. (2mks)

7. Study the solubility curves below and answer the questions that follows:

What happens when a solution containing 40g of potassium chlorate in 100g of water at 90°C is cooled to 40°C ? Explain (3mks)

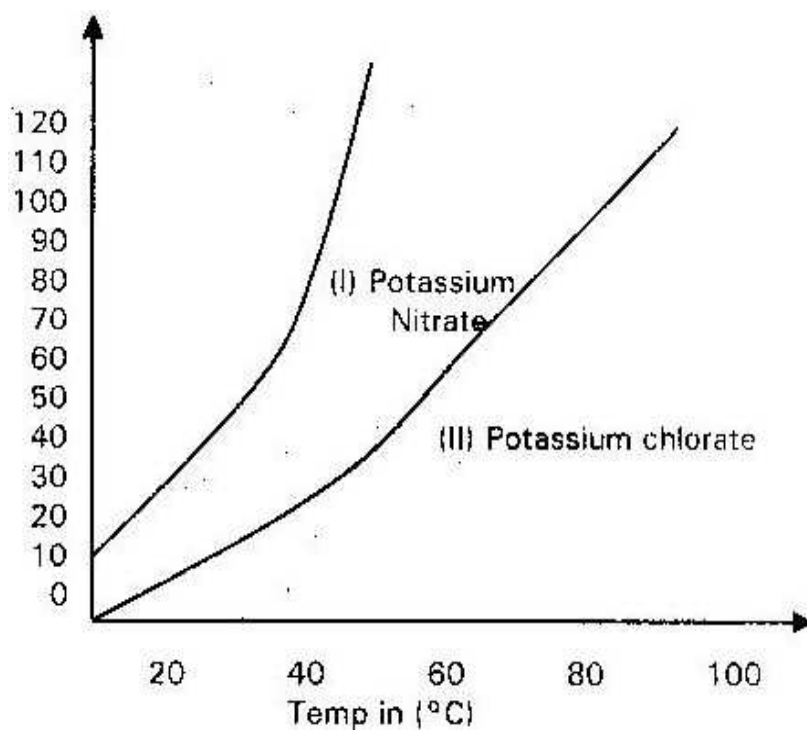

8. Sample solutions of salts were labeled as I, II, III and IV. The actual solutions not in that order are lead nitrate, zinc sulphate, potassium chloride and calcium chloride.

a) When aqueous sodium carbonate was added to each sample, separately, a white precipitate was formed in I, III, IV only. Identify solution II. (1mk)

b) When aqueous sodium hydroxide was added to each sample, separately, a white precipitate was formed in III only. Identify solution III.

c) When excess aqueous sodium hydroxide was added to each sample, separately, white precipitate was formed in III only. Identify solution III.

(3mks)

9.

State one use of sodium hydrogen carbonate.

(1mk)

10.

a) Starting with magnesium oxide solid, describe how a solid sample of magnesium hydroxide can be prepared.

(2mks)

b) Give one use of magnesium hydroxide.

(1mk)

11. Study the flow chart below and answer the questions that follows:

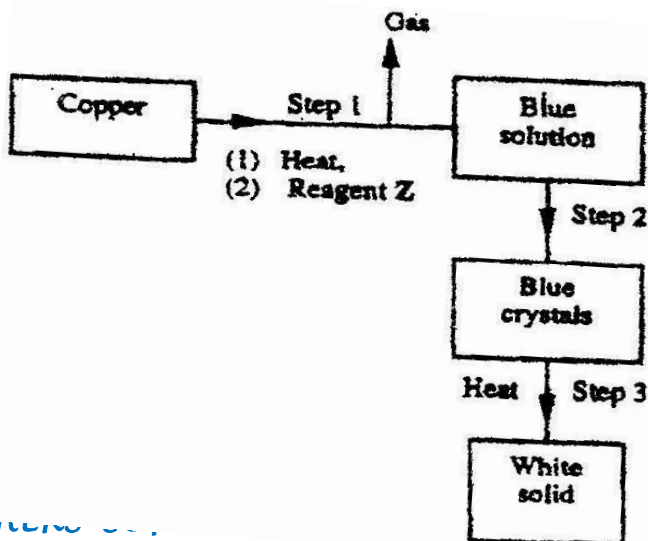

- a) Name reagent Z (1mk)
- b) Describe the process which takes place in step 2. (1mk)
- c) Identify the white solid (1mk)

12.

- a) Name the process that take place when crystals of zinc nitrate change into solution when exposed to air. (1mk)

13.

Starting with sodium metal, describe how a sample of crystals of sodium hydrogen carbonate may be prepared. (3mks)

14.

Starting with copper metal, describe how a sample of crystals of copper (II) chloride may be prepared in the laboratory. (3mks)

15.

The flow chart below shows analysis of mixture "R" that contains two salts.

- a) Study the analysis and answer the questions that follows:-

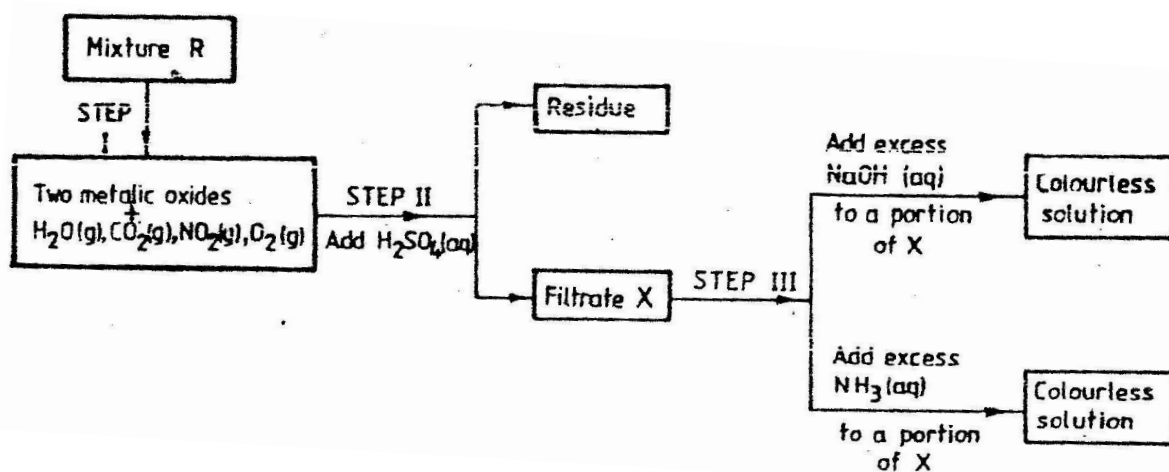

- i) What conditions are necessary for the process in step I to take place? (1mk)
- ii) Draw a labelled diagram to the set up that could be used to separate the mixture formed in step II. (2mks)
- iii) Write an ionic equation for the reaction between the cation in filtrate X and aqueous ammonia (1mk)
- iv) What observations would indicate the presence of $\text{NO}_2(\text{g})$ in step I. (1mk)
- v) State how the water vapour in step I could be identified. (1mk)

b)

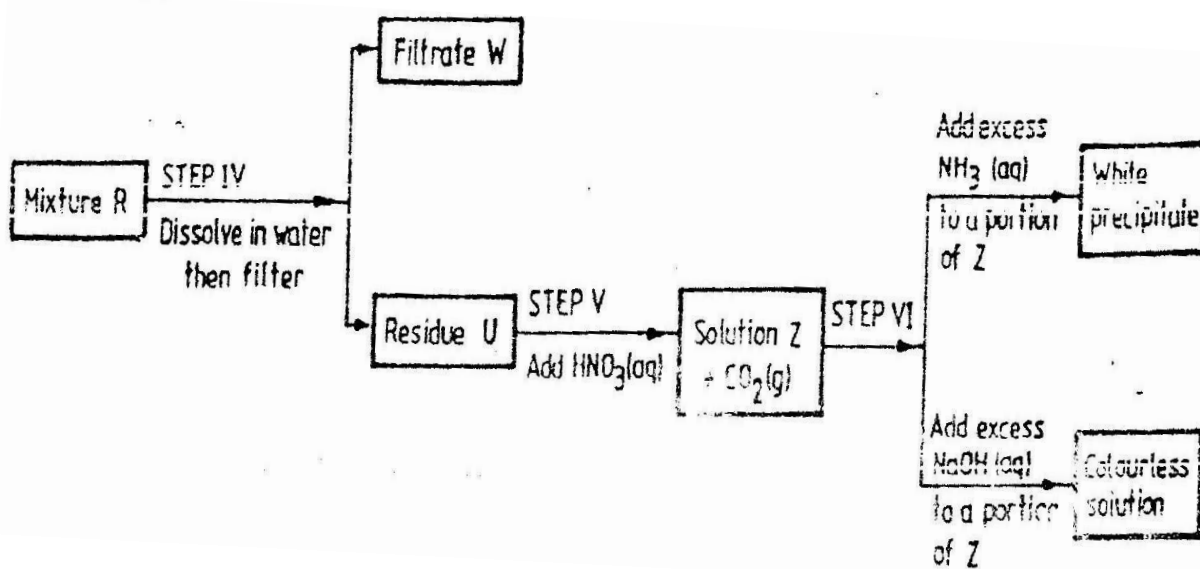

- i) What conclusion can be drawn from step (IV) only? Explain (2mks)
- ii) Write the formula of an anion present in residue U. Explain.(2mks)
- iii) Suggest the identity of the cations present in solution Z. (1mk)
- c) Name the two salts present in mixture R. (2mks)

16.

- a) Give the name of each of the following processes described below which takes place when the salts are exposed to air for some time.
 - i) Anhydrous copper sulphate becomes blue and wet. (1mk)
 - ii) Magnesium chloride forms an aqueous solution. (1mk)
 - iii) Freshly crystals of sodium carbonate, $\text{Na}_2\text{CO}_3 \cdot 10\text{H}_2\text{O}$, become covered with a white powder of formula, $\text{Na}_2\text{CO}_3 \cdot \text{H}_2\text{O}$ (1mk)
- b) Write the formula of the complex ion formed in each of the reactions described below:-
- c) A hydrated salt has the following composition by mass iron 20.2%, Oxygen 23.0%, sulphur 11.5%, Water 45.3%. Its relative formula mass is 278. Determine the formula of the hydrated salts. (3mks)
 - i) 6.95g of the hydrated salts were dissolved in distilled water and the total volume made to 250 cm^3 of the solution. Calculate the concentration of the salt solution in moles per litre. (2mks)

17

During the electrolysis of aqueous copper (II) sulphate using copper electrodes, a current of 0.2 amperes was passed through the cell for 5 hours.

- i) Write an ionic equation that took place at the anode (2mks)
- ii) Determine the change in the mass of the anode which occurred as a result of the electrolysis process. (Cu = 63.5, IF =96500 coulombs). (3mks)

18.

The table below gives the solubilities of hydrated copper (II) sulphate in mol/ dm³ at different temperature:

Temperature (°C)	Solubilities mol/dm ³
20	8x10 ⁻²
40	12 x 10 ⁻²
60	16x10 ⁻²
80	22x10 ⁻²
100	30x10 ⁻²

- i) On the the graph paper (provided) plot a graph of solubility of copper (II) sulphate (Vertical Axis) against temperatures (3mks)
- ii) From the graph, determine the mass of copper (II) sulphate deposited when the solution is cooled from 70⁰C to 40⁰C. (Molar mass of hydrated copper (II) Sulphate is 250g.) (2mks)
- b) In an experiment to determine the solubility of sodium chloride, 5.0 cm³ of a saturated solution of the sodium chloride, 5.0 cm³ of a saturated solution of the sodium chloride solution weighing 5.35g were placed in a volumetric flask and diluted to a total volume of 250cm. 25 cm³ of the dilute solution of sodium chloride completely reacted with 24.1 cm³ of 0.1m silver nitrate solution

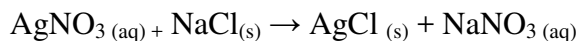

Calculate

- i) Moles of silver nitrate in 24.1cm^3 of the solution. (1mk)
- ii) Moles of sodium chloride in 25.0cm^3 of solution. (1mk)
- iii) Moles of sodium chloride in 250cm^3 of saturated sodium chloride. (1mk)
- iv) Mass of water in 5.0cm^3 of saturated sodium chloride. (1mk)
- v) Mass of water in 5.0cm^3 of saturated solution of sodium chloride. (1mk)
- vi) Solubility of sodium chloride in g/100g water (2mks)

19.

- a) At 25°C , 50g of potassium nitrate were added to 100g of water to make a saturated solution. What is meant by saturated solution? (2mks)
- b) The table below gives the solubilities of potassium nitrate of different temperatures.

Temperature ($^\circ\text{C}$)	12	20	28	36	44	52
Solubility in /100 water	22	31	42	55	70	90

- i) Plot a graph of the solubility of potassium nitrate (Vertical axis) against temperature.
- ii) Use the graph
 - a) Determine the solubility of potassium nitrate at 15°C . (1mk)

- b) Determine the mass of nitrate that remained undissolved given that 80g of potassium nitrate were added to 100 cm³ of water and warmed to 40C. (2mks)

20.

- a) The table below shows the solubility of ammonium phosphate in water at different temperatures.

Temperature (°C)	Solubility of ammonium phosphate in g/100g water
10	63.0
20	69.0
30	75.0
40	82.0
50	89.0
60	97.0

- i) On the grid provided, draw the solubility curve of ammonium phosphate. (Temperature on x-axis). (3mks)
- ii) Using the graph, determine the solubility of ammonium phosphate at 25°C. (1mk)
- iii) 100g of a saturated solution of ammonium phosphate was prepared at 25°C
- I) What is meant by a saturated solution? (1mk)
- II) Calculate the mass of ammonium phosphate which was used to prepare the saturated solution. (2mks)

21. Study the chart below and answer the questions that follows:

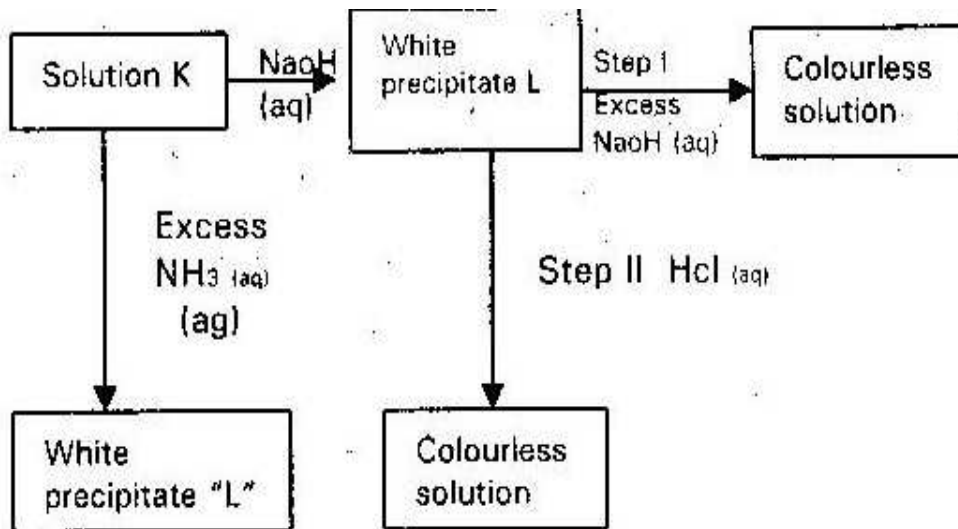

- a) Identify:-
- i) The cation in the solution K (1mk)
 - ii) The white precipitate "L" (1mk)
- b) What property of white precipitate L is illustrated in steps I and II. (1mk)

22. Study the flow chart below and answer the questions that follows:

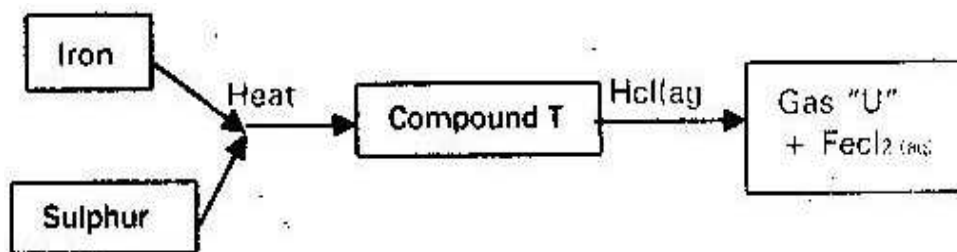

- a) Name (i) Compound T (1mk)
- (ii) Gas "U" (1mk)

- b) Give a chemical test that you would use to identify gas U.
23. Potassium sulphite gave white precipitate with Barium Nitrate solution. An addition of dilute Hydrochloric Acid, the white precipitate disappears.
- a) Write the formula of the compound which formed the white precipitate. (1mk)
- b) Write the equation for the reaction between dilute hydrochloric acid and the compound whose formula is written in (a) above. (1mk)
25. 0.63g of lead powder dissolved in excess nitric acid to form Lead Nitrate solution. All the Lead Nitrate solution was reacted with sodium sulphate solution was reacted with sodium sulphate solution. (1mk)
- a) Write an ionic equation for the reaction between lead nitrate and sodium sulphate solution. (1mk)
- b) Determine the mass of Lead salt formed in (a) above. (Pb= 207) (S= 32) (O=16) (2mks)
26. Study the scheme below and answer questions that follow

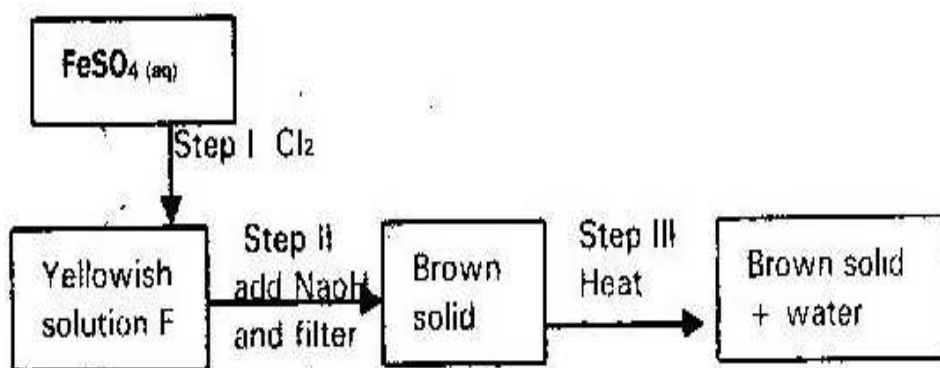

- a) Write the formula of the cations present in F. (1mk)

- b) What property of chlorine is shown in step I? (1mk)
- c) Write an equation for the reaction which occurs in step (III). (1mk)
27. The scheme below shows some reactions sequence starting with solid N.

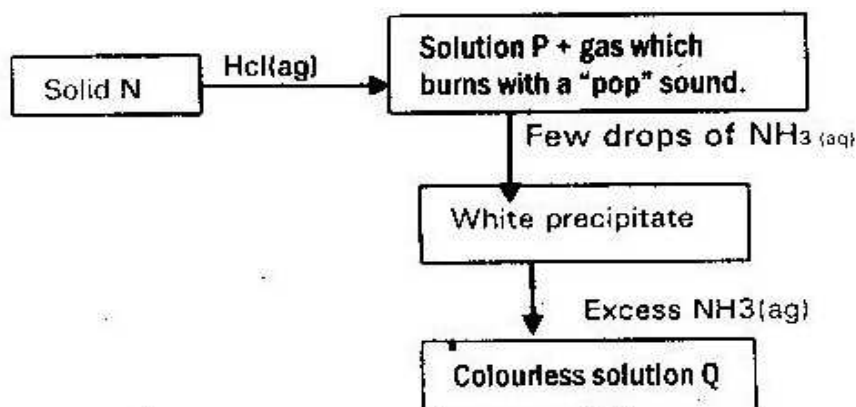

- a) Name solid N. (1mk)
- b) Write the formula of complex ions present in solution Q. (1mk)
28. When pellets of sodium hydroxide are exposed to air, a solution is formed which gradually disappears leaving a white powder. Explain. (2mks)
29. What observation is made when hydrated copper (II) sulphate is heated gently?
30. Study the scheme below for the laboratory preparation of precipitate "V" and answer the questions that follow

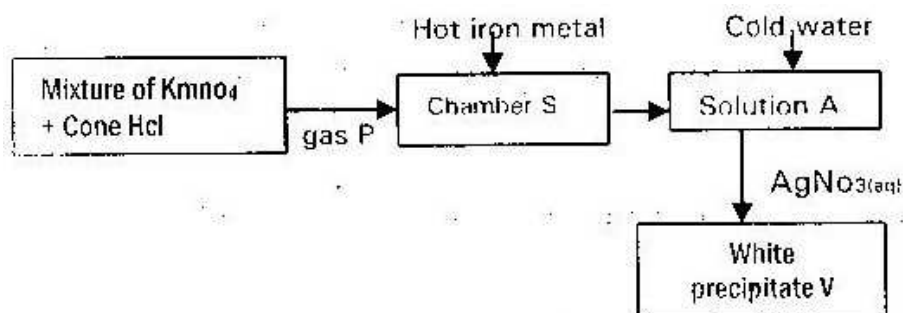

- a) What observations is made when aqueous ammonia is added to 2 cm³ of solution "A". Explain. (2mks)
- b) State and explain the observation made when aqueous ammonia is added to spatula- end full of white precipitate "V". (2mks)

TOPIC 5

CARBON AND SOME OF ITS COMPOUNDS

1. Give two properties of carbon (IV) oxide which make it suitable for use in extinguishers. (2mks)

2. Give a reason why calcium hydroxide solution is used to detect the presence of Carbon (IV) oxide gas while sodium hydroxide solution is NOT (1mk)

3. A sample of air contaminated with carbon (II) oxide and sulphur (IV) oxide was passed through the apparatus shown below.

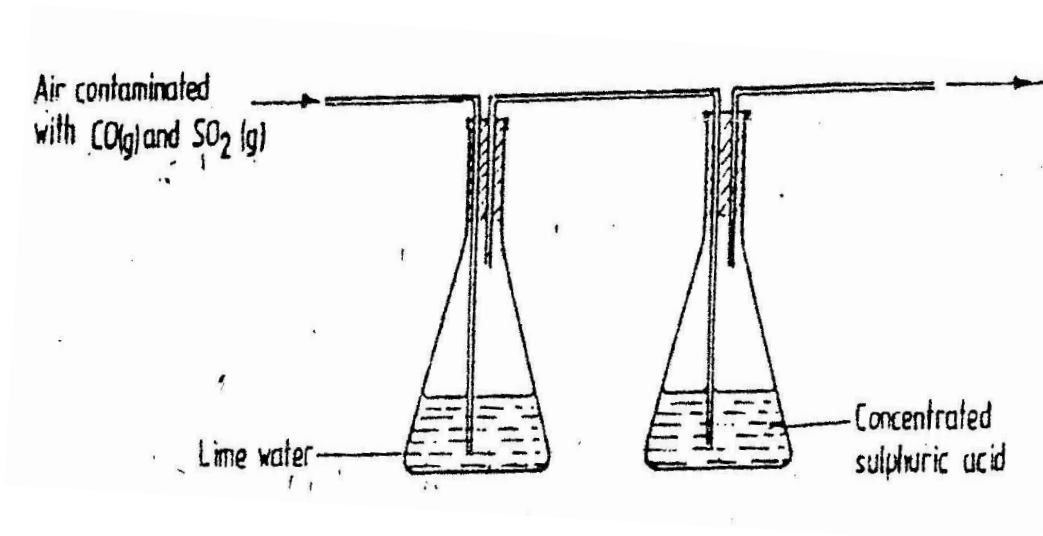

Which contaminant was removed by passing the contaminated air through the apparatus. Explain (2mks)

4. The decomposition of calcium carbonate can be represented by the equation.

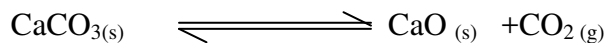

Explain how an increase in pressure would affect the equilibrium position (2mks)

- 5.

Explain how you would obtain solid sodium carbonate from a mixture of lead carbonate powder. (2mks)

- 6.

When extinguishing a fire caused by burning kerosene, carbon (IV) oxide is used in preference to water. Explain (2mks)

- 7.

When dilute nitric acid was added to a sample of solid "C" a colourless gas that formed a white precipitate with lime water was produced. When another sample of solid "C" was heated strongly in a test tube, there was no observations changes. Write the formula of the ions in solid "C" (2mks)

8.

The diagram below represents a charcoal burner. Study it and answer the questions that follows:

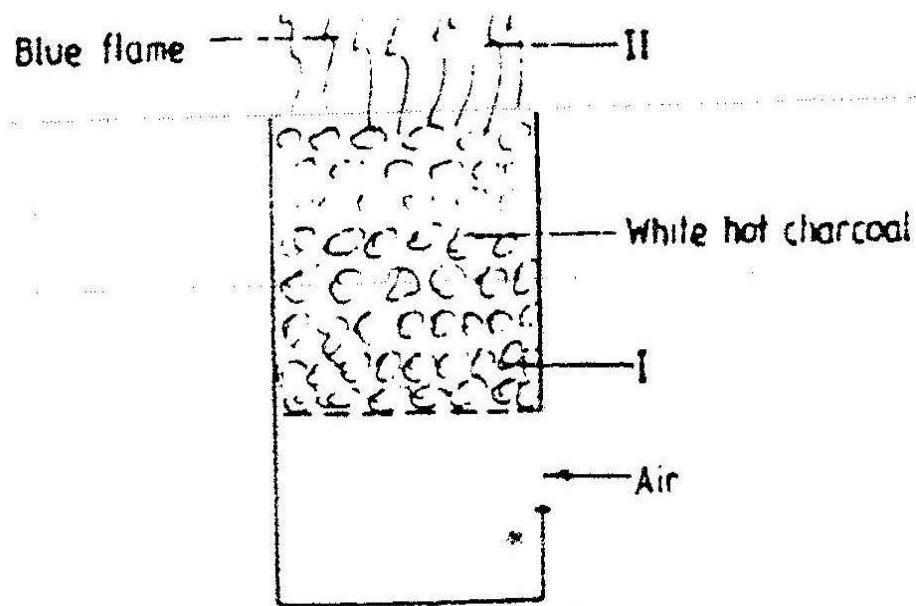

Write equations for the reactions taking place at I and II (2mks)

9. When excess carbon (IV) oxide passed over heated lead (II) oxide in combustion tube, lead (II) oxide was reduced.

- Write an equation for the reaction which took place. (1mk)
- What observations was made in the combustion tube when the reaction was complete? (1mk)
- Name another gas which would be used to reduce lead (II) oxide. (1mk)

10.

The simplified flow chart shows some of the steps in the manufacturing of the sodium carbonate by the solvey process.

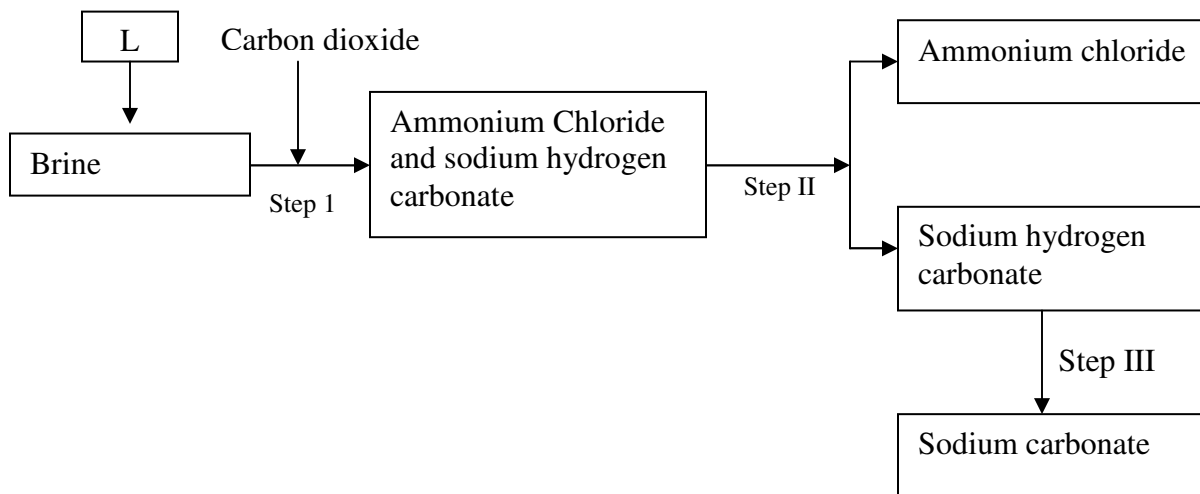

- Identify substance L
- Name the process taking place in step II
- Write an equation for the reaction which take place in step III. (1mk)

11. Use the scheme below to answer the questions

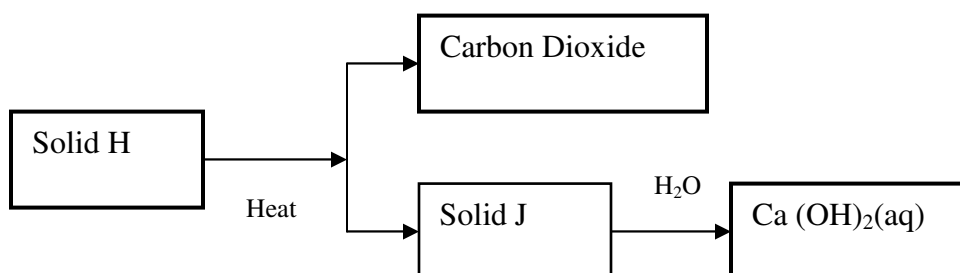

- a) Identify the solids H and J (2mks)
- b) State one commercial use of solid J. (1mk)
12. State any two difference between luminous flame and non luminous flame.(2mks)
- 13.

The apparatus shown below was used to investigate the effect of carbon (II) oxide on copper (II) oxide.

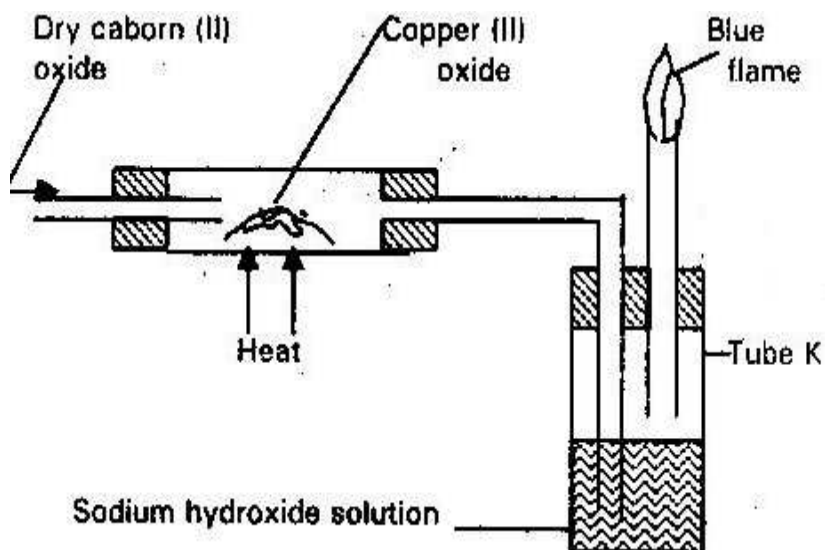

- a) State the observation that was made in the combustion tube at the end of the experiment.
- b) Write an equation for the reaction that took place in the combustion tube
- c) Why is it necessary to burn the gas coming out of tube K?

14.

When carbon (IV) oxide gas was passed through aqueous calcium hydroxide a white suspension/ precipitate was formed.

- a) Write an equation for the reaction that took place in the combustion tube. (1mk)
- b) State and explain the change that would occur when excess carbon (IV) oxide gas is bubbled through the white suspension. (1mk)

15.

A certain GCO_3 reacts with dilute Hydrochloric acid according to the equation given below.

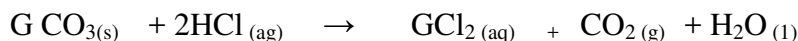

If 1 g of the carbonate reacts completely with 20cm^3 of 1m Hydrochloric acid.

Calculate the relative atomic mass of G. (C= 12.0, O = 16.0) (3mks)

16. In the industrial extraction of lead metal, the ore is first roasted in a furnace. The solid mixture obtained is then fed into another furnace together with coke, limestone and scrap iron. State the functions of the following in the process.

- a) Coke (1mk)
- b) Lime stone (1mk)
- c) Scrap iron (1mk)

17.

When calcium carbonate is heated, the equilibrium shown below is established.

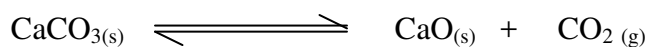

How would the position of the equilibrium be affected if a small amount of dilute potassium hydroxide is added to the equilibrium mixture. Explain (2mks)

18.

The set up below was used to obtain a sample of iron

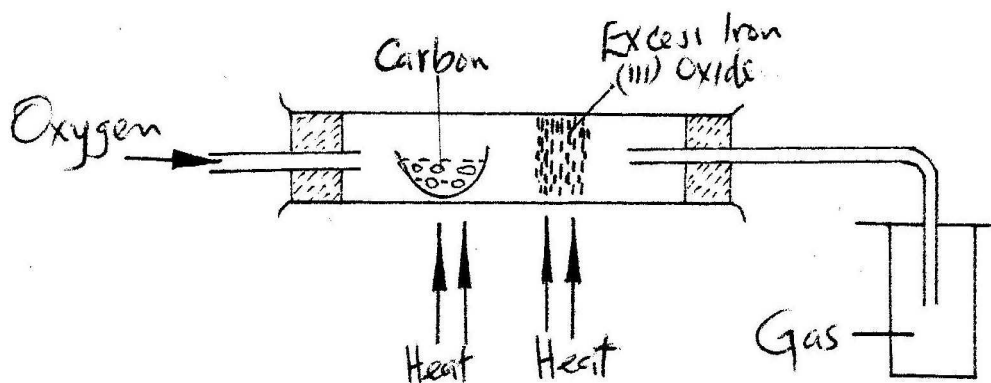

Write two equations for the reactions which occur in the combustion tube. (2mks)

19.

Dry carbon (II) oxide gas reacts with heated lead (II) oxide as shown in the equation below.

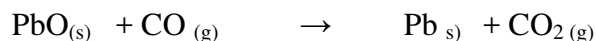

- Name the process undergone by the lead (II) oxide. (1mk)
- Give a reason for your answer in (a) above. (1mk)
- Name another gas that can be used to perform the same function as carbon (II) oxide gas in the above reaction. (1mk)

20.

In an experiment to study the properties of concentrated sulphuric acid, a mixture of the acid and the wood charcoal was heated in a boiling tube.

a) Write the equation of the reaction that took place in the boiling tube. (1mk)

b) Using oxidation numbers, show that reduction and oxidation reactions took place in the boiling tube. (2mks)

21. Name the process:-

Solid carbon (IV) oxide (dry ice) changes directly into gas. (1mk)

22. The diagram below represent part of the set up used to prepared and collect gas T.

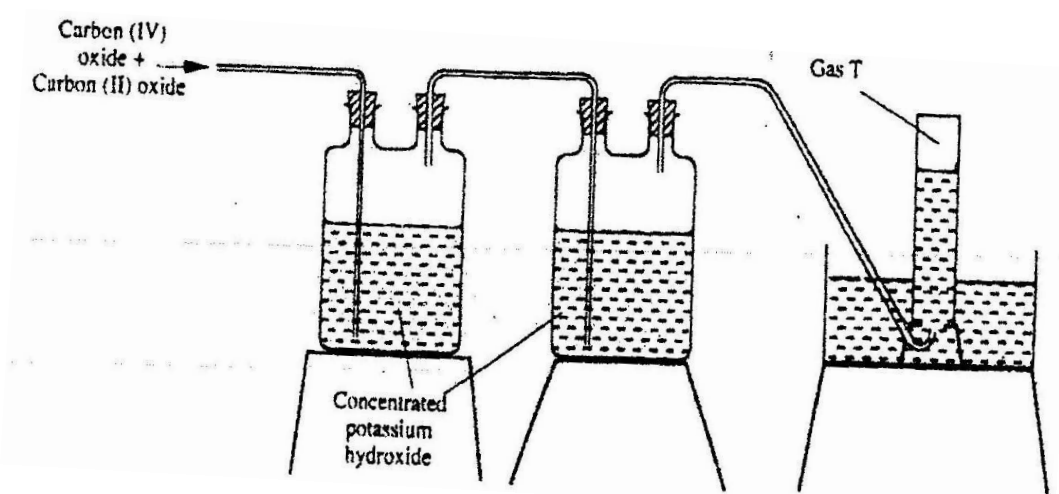

a) Name two reagents that reacted to produce both carbon (IV) oxide and carbon (II) oxide. (1mk)

b) Write the equation for the reaction which takes place in the wash bottle. (1mk)

c) Give a reason why carbon (II) oxide is not easily detected. (1mk)

23. The diagram below shows a jiko when in use. Study it and answer the questions that follow.

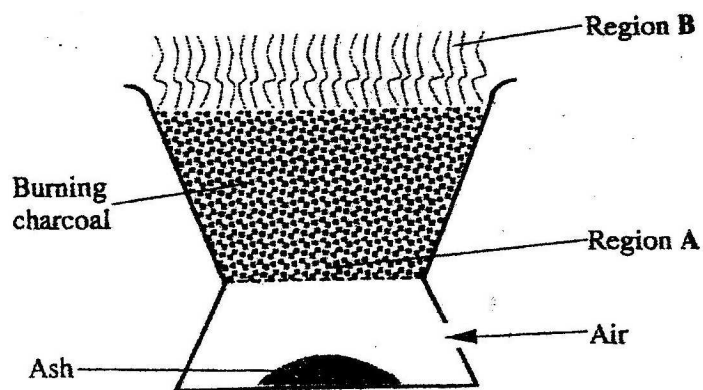

- a) Identify the gas formed at region A. (2mks)
- b) State and explain the observation made at region B. (2mks)
24. The set-up below was used to collect a dry sample of a gas

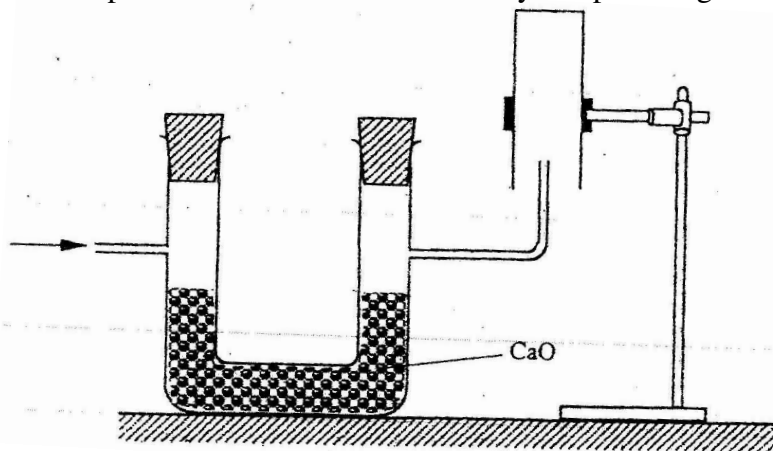

Give two reasons why the set-up cannot be used to collect carbon (IV) oxide gas.

(2mks)

25. a) Explain why permanent hardness in water cannot be removed by boiling. (2mks)
- b) Name two methods that can be used to remove permanent hardness from water. (1mk)

26.

When solid B_1 was heated, a gas which formed a white precipitate when passed through lime water was produced. The residue was dissolved in dilute nitric (V) acid to form a precipitate which dissolved on warming was formed.

- a) Write the formula of the:
- I. Cation in solid B_1 (1mk)
- II. Anion in solid B_1 (1mk)
- b) Write an ionic equation for the reaction between the residue and dilute nitric (V) acid

27.

The flow chart below illustrates the industrial extraction of lead metal. Study it and answer the questions that follow

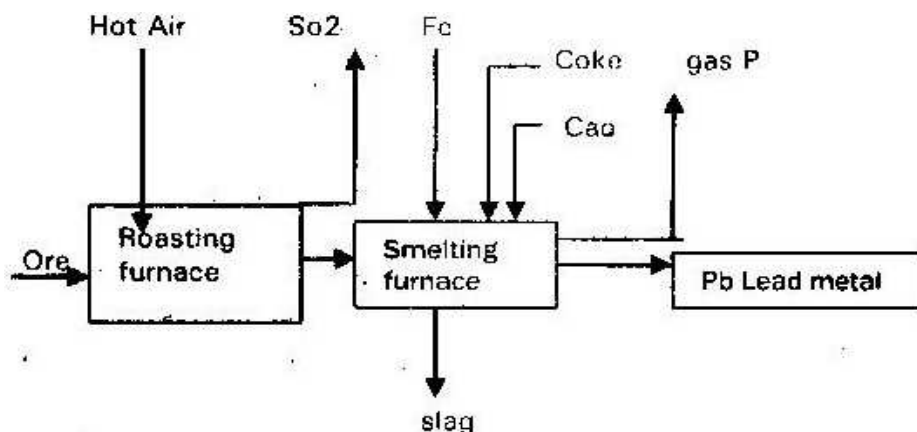

- a) i) Name the ore that is commonly used in this process. (1mk)
- ii) Explain what takes place in the roasting furnace. (1mk)
- iii) Identify gas P (1mk)
- iv) Write the equation for the main reaction that takes place in the smelting furnace. (1mk)
- v) Give two environmental hazards likely to be associated with extraction of lead. (2mks)
- b) Explain why hard water flowing in lead pipes may be safer for drinking than soft water flowing in the same pipes. (3mks)
- c) State one use of lead other than the making of lead pipes.
28. In an experiment, carbon (IV) Oxide gas was passed over heated charcoal and the gas produced collected as shown in diagram below.

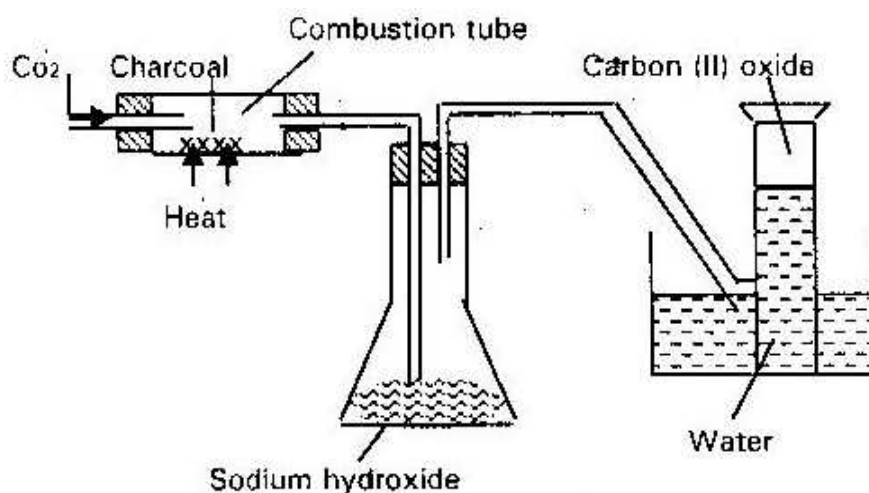

- i) Write an equation for the reaction that took place in the combustion tube.
(1mk)
- ii) Name another substance that can be used instead of sodium hydroxide.
(1mk)
- iii) Describe a simple chemical test that can be used to distinguish between carbon (II) oxide and carbon (IV) oxide.
(2mks)
- iv) Give one use of carbon (II) oxide
(1mk)

29.

The scheme below shows some reactions starting with calcium oxide. Study it and answer the questions that follows.

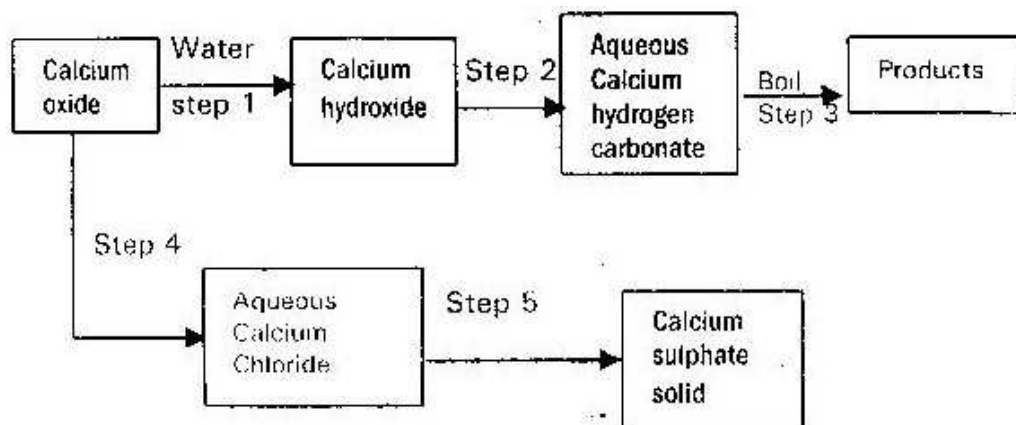

30.

Carbon exists in different crystalline forms. Some of these forms were recently discovered in soot and are called fullerenes.

- i) What name is given to different crystalline forms of the same element?
(1mk)
- ii) Fullerenes dissolve in methylbenzene while the other forms of carbon; describe how crystals of fullerenes can be obtained from soot. (3mks)
- iii) The relative molecular mass of one of the fullerenes is 720. What is the molecular of this fullerene? (C=12.0) (1mk)

31. When extinguishing fire caused by petrol, carbon (IV) oxide is used in preference to water. Explain. (2mks)

32. Write an equation for the reaction that occurs when carbon (II) oxide is passed over heated Copper (II) oxide.

33. Use the flow chart below to answer the questions that follows.

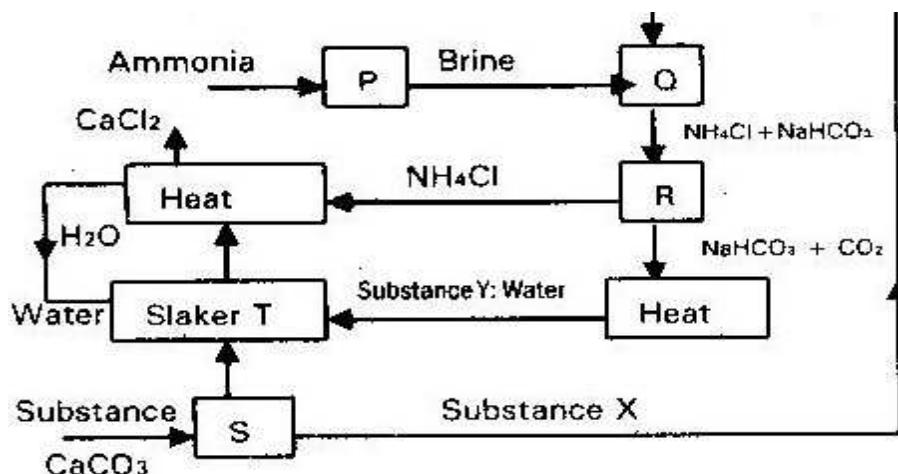

- i) Name the process that take place in S and R (2mks)
- ii) state one use of calcium chloride CaCl_2 (1mk)
- iii) Write the equation for the reactions that take place in
Q. (1mk)
- Slaker I (1mk)
- b) Explain how sodium carbonate can be used to soften hard water. (1mk)
- c) Give one commercial use of sodium carbonate (1mk)
- d) X grams of sodium carbonate ($\text{Na}_2\text{CO}_{3(s)}$) react completely with 30cm^3 of dilute hydrochloric acid to produce 672cm^3 of carbon (IV)oxide at STP (Ma=23)
- (i) Write the equation for the reaction. (1mk)
- (ii) Calculate the concentration of the acid in moles per litre. (2mks)
- (iii) Calculate the value of “X” (2mks)
34. a) Explain the following
- i) Temporary hardness in water (1mk)
- ii) Permanent hardness in water. (1mk)
- b) i) Draw a diagram and explain how ionic exchanger works. (3mks)
- ii) Explain why hard water is recommended for healthy development of teeth. (2mks)

35. When a solid "T" is heated, a black solid is left and a colourless gas which form white precipitate with lime water is evolved. Identify "T" and write an equation for the decomposition of "T". (2mks)
36. State the confirmation test for the following gases:-
- Carbon (II) oxide (1mk)
 - Carbon (IV) oxide (1mk)
37. Explain why dilute sulphuric acid does not react fully with calcium carbonate while dilute Hydrochloric acid react fully with the same liberating carbon (IV) oxide. (2mks)
38. Name the process in each case by which carbon (IV) is constantly being
- Added to the atmosphere (1mk)
 - Removed from the atmosphere (1mk)
39. A compound contains 40% carbon, 6.67% hydrogen and the rest is oxygen. Find the simplest formula for this compound. (C=12) (H=1) (O=16) (2mks)
40. Below is a set up used by a student to prepare gas n

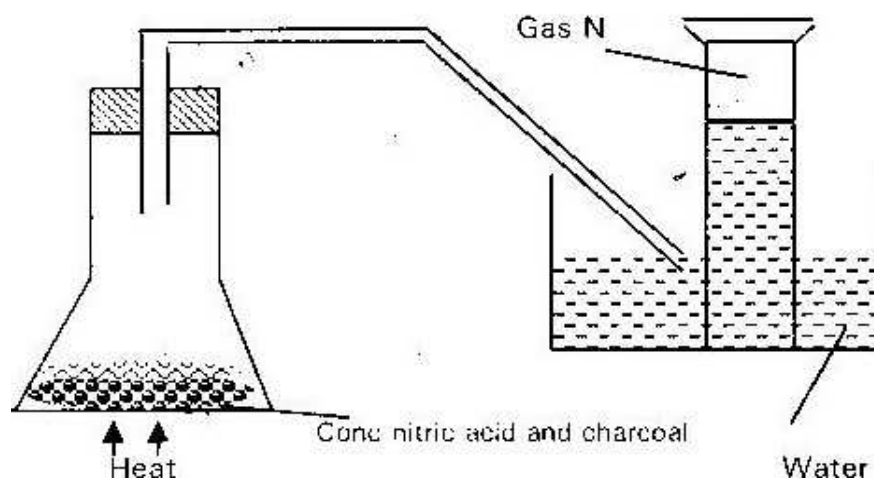

- i) Identify gas "N" (1mk)
- ii) Explain why it was possible to isolate gas N. (1mk)
- iii) Comment of the PH of the water after the experiment (1mk)

FORM 3 WORK

TOPIC 1

GAS LAW

1.

Explain why the volume of a gas increases when its temperature is increased at a constant pressure. (1 mk)

Cotton wool pads were soaked with concentrated solutions of gas “p” and gas “Q” the pads were then placed of the opposite ends of a long horizontal glass tube at the same time. The tube was then immediately corked at both ends as shown the diagram below.

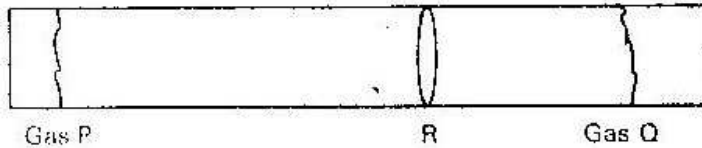

After sometimes the gases were observed to meet at point “R” which of the two gases is dense? Explain your answer (2 mks)

2.

A mixture containing equal volumes of hydrogen and carbon (IV) oxide was introduced as shown below

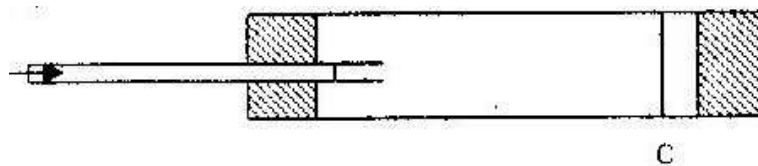

Which gas would be detected at point “C” first? Explain (2 mks)

3.

In an experiment to study diffusion of gases a student set up the apparatus shown in the diagram I. After sometime the student noticed a change in the water level as shown in diagram II.

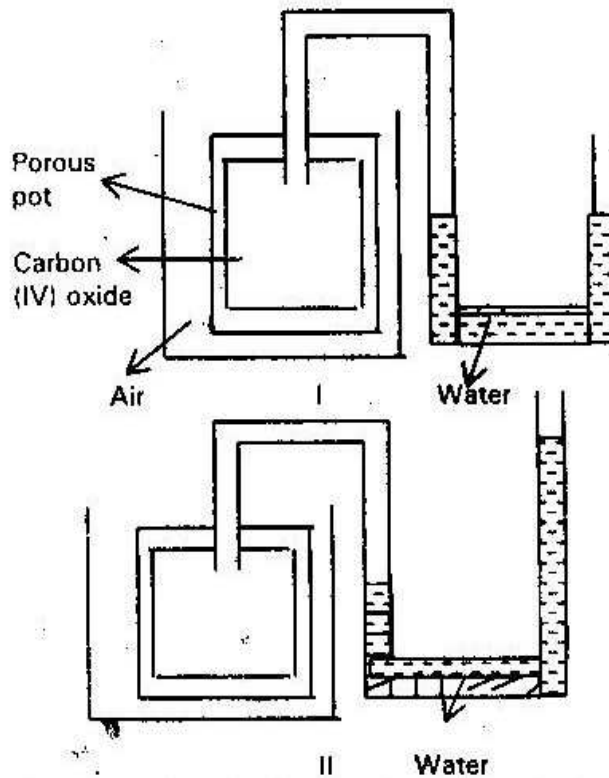

Give an explanation for the change in water level

(2 mks)

4. A fixed mass of gas has a volume of 250 cm^3 at a temperature of 270° and 750 mm Hg pressure. Calculate the volume the gas would occupy at 42°C and 750 mm Hg pressure.
5. A gas occupies a volume of 400 cm^3 at 500k and atmospheric pressure. What will be the temperature of the gas when the volume and pressure of the gas is 100 cm^3 and 0.5 atmospheric pressure respectively? (2 mks)
6. A sealed glass tube containing air at S.T.P was immersed in water at 100°C . Assuming there was no increase in volume of the glass tube due to expansion of the glass. Calculate the pressure of the air inside the tube.
Standard pressure = 760mmHg : Standard temperature = 273 K . (2 mks)
7. A given volume of Ozone (O_3) diffused from a certain apparatus in 96 seconds. Calculate the time taken by equal volume of carbon (IV) oxide (CO_2) to diffuse under the same condition (O= 16) (C=12) (2 mks)
8. A few crystals of potassium manganate VII were carefully placed in a beaker at one spot. The beaker was left undisturbed for two hours. State and explain the observation that was made. (2 mks)
9. The graph below shows the behaviour of a fix mass of a gas at constant temperature.

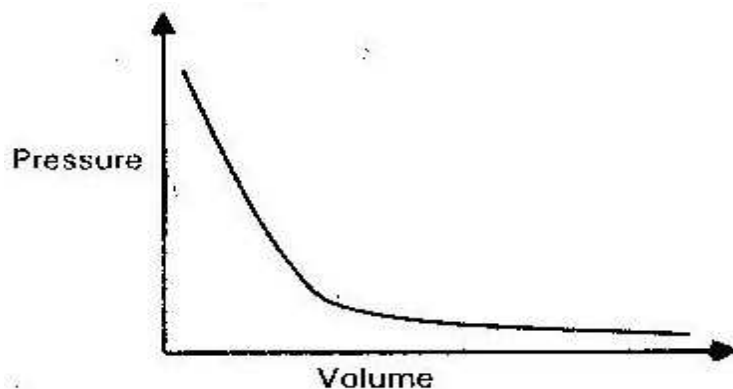

(a) What is the relationship between the volume and the pressure of the gas

(1 mk)

(b) 3 litres of oxygen gas at one atmospheric pressure were compressed to two atmospheres at constant temperature. Calculate the volume occupied by oxygen gas.

(2 mks)

10.

When a hydrocarbon was burnt completely in oxygen, 4.2 g of carbon (IV) oxide and 1.71 g of water were formed. Determine the empirical formula of the hydrocarbon (H= 1.0) (C=12)

(3 mks)

11.

60cm³ of oxygen gas diffused through a porous partition in 50 seconds. How long would it take 60cm³ of sulphur (IV) oxide gas to diffuse through the same conditions? (S= 32.0) (O=16.0).

(3 mks)

- 12.
- (a) State Charles law
- (b) The volume of a sample of hydrogen gas at temperature 291K and 1.0×10^5 pascals was $3.5 \times 10^{-2} \text{m}^3$. Calculate the temperature at which the volume of the gas would be $2.8 \times 10^{-2} \text{m}^3$ at 1.0×10^5 pascals. (2 mks)
13. A small crystal of potassium (VII) was placed in a beaker containing water. The beaker was left standing for two days without shaking. State and explain the observations that were made.
14. (a) State the Graham's law of diffusion (1 mark)
- (b) The molar masses of gases w and x are 16.0 and 44.0 respectively. If the rate of diffusion of w through a porous material is $12 \text{cm}^3 \text{S}^{-1}$, calculate the rate of diffusion of x through the same material. (2 marks)
15. Calculate the R.F.M of gas "A" given that the time taken for equal volumes of oxygen and gas "A" to diffuse through a hole is 20 seconds and 24 seconds respectively (O= 16.0) (2 mks)
16. A certain volume of CO_2 gas takes 200 seconds to diffuse through porous plug. How long would it take the same volume of HCL to diffuse under the same condition? (3 mks)
17. What volume of a butane (C_4H_{10}) must be burnt in oxygen to give 11g of CO_2 at r.t.p?
- The equation for the combustion of butane is given below
- $$2 \text{C}_4\text{H}_{10} (\text{g}) + 13 \text{O}_2 (\text{g}) \rightarrow 8\text{CO}_2 (\text{g}) + 10\text{H}_2\text{O} (\text{l})$$
18. The set up shown below was used to investigate some properties of two gases "P" and Q

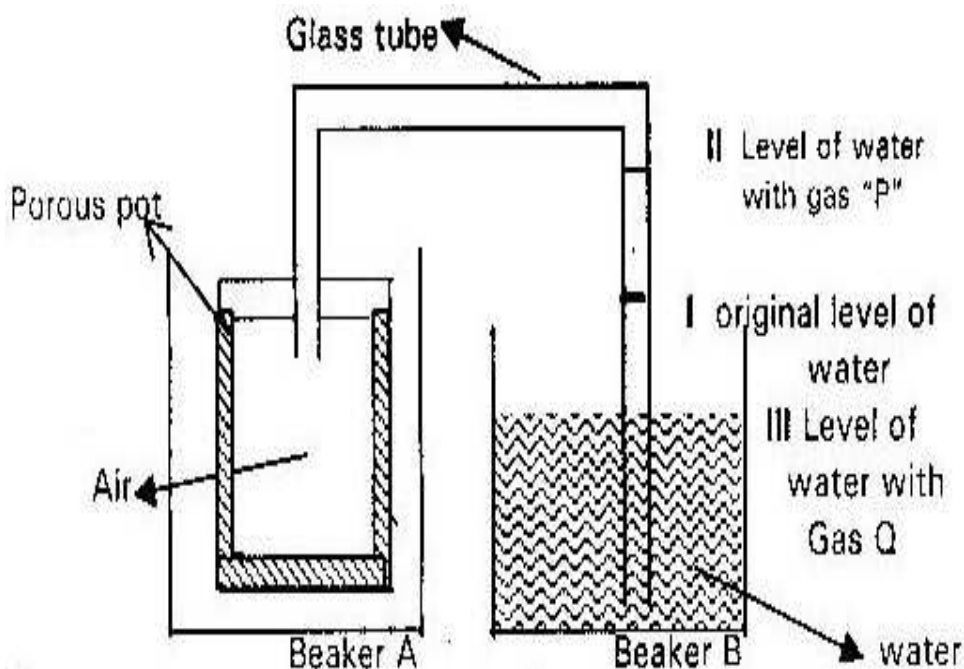

When beaker A was filled with gas P the level of water in the glass tubing rose to level II. When the experiment was repeated using gas Q, the level of water dropped to level III. Explain these observations.

19. Study the set up below and answer the questions that follows

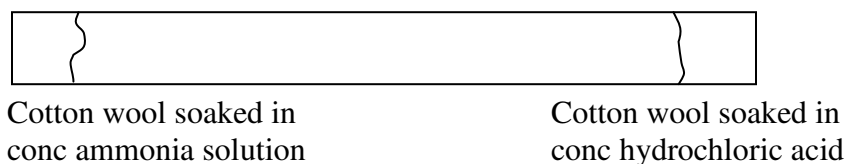

- (i) What observations would be made in the tube (1 mk)
- (ii) Indicate with a cross (x) on the diagram the likely position where the observation stated in (i) above would be made. (1 mk)
- (iii) Write an equation for the reaction that takes places in the set up above

(1 mk)

20. 88 cm^3 of gas K diffuse through a small hole in 40 seconds while 50 cm^3 of hydrogen gas diffuse through the same hole under the same conditions in 5 seconds. Calculate the RMM of the gas K (3 mks)

21. 200 cm^3 ammonia gas are burnt in 300 cm^3 of oxygen gas (excess). 200 cm^3 of nitrogen (II) oxides and 300 cm^3 steam were formed. 50 cm^3 of oxygen was left unused. Deduce the equation for this reaction. (3 mks)

22. Sketch a demonstration graph showing variation of pressure of a gas against volume at a constant temperature. (2 mks)

23. Nitrogen gas occupies a volume of 200 cm^3 at 25°C . What will be the temperature of nitrogen if it occupied a volume of 300 cm^3 ? (2 mks)

24. What will be the volume of a certain mass of nitrogen gas at 20°C if it occupies 200 cm^3 at 25°C pressure remain constant. (2 mks)

25. 200 cm^3 of gas "p" at s.t.p was cooled and the volume contracted to 160 cm^3 . Calculate the new temperature of the gas in $^\circ\text{C}$ if the pressure is kept constant.

26. Form three students found that a mass of nitrogen gas occupies 330 cm^3 at 280°C and 760 mm Hg pressure. At what temperature will the volume of the gas be 190 cm^3 and the pressure 800 mm Hg ?

TOPIC 2

THE MOLE

1. When 34.8g of hydrated sodium carbonate $\text{Na}_2\text{CO}_3 \cdot \text{XH}_2\text{O}$ were heated to a constant mass, 15.9g of anhydrous sodium carbonate were obtained. Find the value of "X" in hydrated carbonate (Na= 23), (O = 16), (C= 12), (H = 1.0)

(3 mks)

2. Hydrogen reacts with oxygen as shown in the equation

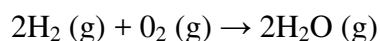

In an experiment 100cm^3 of hydrogen gas was mixed with 100cm^3 oxygen gas and the mixture heated to form H_2O . Which of the gas was in excess and how much.

(2 mks)

3. Calculate the amount of calcium carbonate that would remain if 15.0g of calcium carbonate were reacted with 0.2 moles of hydrochloric acid. The equation for the reaction is.



(C = 12), (O = 16) (Ca = 40)

(2 mks)

4. 1995: PP1 A Questions 14

A compound has an empirical formula $\text{C}_3\text{H}_6\text{O}$ and a relative formula mass of 116

- (a) Determine its molecular formula

(H= 1.0) (C = 12.0), (O= 16.0) (2 mks)

- (b) Calculate the percentage composition of carbon by mass in the compound
(1 mk)

5. In an experiment 2.4 g of sulphur was obtained by reacting hydrogen sulphide and chlorine as shown by the equation below

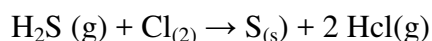

- (a) Which of the reagent acts as a reducing agent? Explain (1 mk)
- (b) Given that the yield of sulphur in the above reaction is 75%. Calculate the number of moles of $\text{H}_2\text{S}_{(g)}$ used in the reaction (S= 32.0) (2 mks)

6.

- (a) The empirical formula of the hydrocarbon is C_2H_3 . The hydrocarbon has a relative molecular mass of 54 (H= 1)

- (i) Determine the molecular formula of the hydrocarbon
- (ii) Draw the structural formula of the hydrocarbon (1 mk)
- (iii) To which homologous series does the hydrocarbon drawn in (ii) above belong (1 mk)

- (b) 90cm^3 of 0.01M calcium hydroxide were added to a sample of water containing 0.001 moles of calcium hydrogen carbonate.

- (i) Write an equation for the reaction which took place (1 mk)
- (ii) Calculate the number of moles of calcium ions in 90cm^3 of 0.01M calcium hydroxide
- (c) What would be observed if soap solution was added dropwise to a sample of the water after the addition of calcium hydroxide? Give a reason (1 mk)
7. Calculate the mass of nitrogen (IV) oxide gas that would occupy the same volume as 10g of hydrogen gas at the same temperature and pressure ($\text{H} = 1.0$), ($\text{N} = 14.0$) ($\text{O} = 16$) (2 mks)
8. On complete combustion of a sample of hydrocarbon, 3.52 g of carbon (IV) oxide and 1.44g of water were formed. Determine the molecular formula of the hydrocarbon. (Relative molecular mass of hydrocarbon is 56) (Carbon (10) oxide = 44) water = 18) ($\text{H} = 1.0$) ($\text{C} = 12.0$) (4 mks)
9. 20.0cm^3 of solution containing 4g per litre of sodium hydroxide was neutralized by 8.0cm^3 of dilute sulphuric acid. Calculate the concentration of sulphuric acid in moles per litre ($\text{Na} = 23.0$) ($\text{O} = 16.0$) ($\text{H} = 1.0$) (3 mks)
10. A weighed sample of crystalline sodium carbonate $\text{Na}_2\text{CO}_3 \cdot \text{N H}_2\text{O}$ was heated in a crucible until there was no further change in mass. The mass of the sample reduced by 14.5 . Find the number of moles (N) of the water of crystallization ($\text{Na} = 23.0$), ($\text{O} = 16.0$), ($\text{C} = 12.0$), ($\text{H} = 1.0$) (3 mks)
11. In an experiment 30 cm^3 of 0.1 sulphuric acid were reacted with 30 cm^3 of 0.1M sodium hydroxide.
- (a) Write an equation for the reaction that took place (1 mk)

(b) State the observations that were made when both blue and red litmus were dropped into the mixture (1 mk)

(c) Give a reason for your answer (1 mk)

12. When excess dilute hydrochloric acid was added to sodium sulphite, 960cm^3 of sulphur (IV) oxide gas was produced. Calculate the mass of sodium sulphite that was used. (Molar mass of sodium sulphite = 126g; and molar gas volume = 24000cm^3) (3 mks)

13. When “X” cm^3 of a solution of 0.5m magnesium nitrate were reacted with excess ammonium carbonate solution, the mass of magnesium carbonate formed was 8.4g.

(a) Write the ionic equation for the reaction that took place (1 mk)

(b) Calculate the value of = “X” (C= 12) (Mg= 24) (O = 16) (2 mks)

14. A certain carbonate of GCO_3 react with dilute hydrochloric acid according to the equation given below.



If 1 g of the carbonate reacts completely with 20cm^3 of 1 m hydrochloric acid, calculate the atomic mass of G (3 mks)

15. When 94.5g of hydrated – barium hydroxide $\text{Ba}(\text{OH})_2 \cdot n\text{H}_2\text{O}$ were heated to a constant mass. 51.3g of anhydrous- barium hydroxide were obtained. Determine

the empirical formula of the hydrated barium hydroxide. (Ba = 137.0) (O= 16),
(H= 1.0)

16.

15.0 cm³ ethanoic acid (CH₃COOH) was dissolved in water to make 500 cm³ of solution. Calculate the concentration of the solution in moles per litre. (C= 12.0; H= 1.0; O = 16.0' density of ethanoic is 1.05g/cm³ (3 mks)

17.

An alkanol has the following composition by mass: Hydrogen 13.5%, oxygen 21.6% and carbon 64. 9%

(a) Determine the empirical formula of the alkanol (C= 12.0; H = 1.0; O = 16.0) (2 mks)

(b) Given that empirical formula and the molecular formula of the alkanol are the same, draw the structure of the alkanol (1 mk)

18.

6.84 of aluminium sulphate were dissolved in 150cm⁻³ of water. Calculate the molar concentration of the sulphate ions in the solution. (Relative formula mass of aluminum sulphate is 342) (3 mks)

19. When a hydrated sample of calcium sulphate CaSO₄. XH₂O was lost, the following data was recorded:

Mass of crucible = 30.296g

Mass of crucible + hydrated salt = 33.111g

Mass of crucible + anhydrous salt = 32.781g

Determine the empirical formula of the hydrated salt (relative formula mass of

$\text{CaSO}_4 = 136$, $\text{H}_2\text{O} = 18$) (3 mks)

20.

Phosphoric acid is manufactured from calcium phosphate according to the following equation.

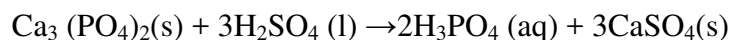

Calculate the mass in (kg) of phosphoric acid that would be obtained if 155 kg of calcium phosphate reacted completely with the acid (Ca = 40, P = 31, S = 32, O = 16, H = 1) (2 marks)

21.

In an experiment to determine the percentage of magnesium hydroxide in an anti-acid, a solution containing 0.50g of the anti-acid was neutralized by 23.0cm³ of 0.10M hydrochloric acid. (Relative formula mass of magnesium hydroxide = 58).

Calculate the:

(a) Mass of magnesium hydroxide in the anti-acid (2 mks)

(b) Percentage of magnesium hydroxide in the anti-acid (1 mark)

22.

(a) Name one raw material from which sodium hydroxide is manufactured
(1 mk)

(b) Sodium hydroxide pellets were accidentally mixed with sodium chloride.
17.6g of the mixture were dissolved in water to make one litre of solution.
100 cm³ of the solution was neutralized by 40 cm³ of 0.5m sulphuric acid.

(i) Write an equation for the reaction that took place (1 mk)

(ii) Calculate the

I. Number of moles of the substance that reacted with sulphuric acid.

II. Number of moles of the substance that would react with acid in
the one litre of solution (1 mk)

(iii) Mass of the un-reacted substances in the one litre of solution

23. (i) A hydrated salt has the following composition By mass: iron 20.2% Oxygen
23.0% sulphur 11.5% and 45.3% water of = crystallization. If RMM= 278

(ii) Determine the formula of the hydrate salt. (2 mks)

(iii) 6.95g of the hydrated salt were dissolved in water and the total volume
made up to 250c³ of solution. Calculate the concentration of the salt
solution in moles per litres (2 mks)

24. 1.9 g of magnesium chloride was dissolved in water. Silver nitrate solution was added till in excess. Calculate the mass of silver nitrate that was added for the complete reaction. (Rmm of magnesium chloride= 95 (m= 14 (O= 16) (Ag = 108).
25. During welding of fractured railway lines by thermite reaction 12g of oxide of iron is reduced by aluminum to 8.4g of iron. Determine the empirical formula of the oxide (Fe= 56) (O= 16) (3 mks)
26. In a titration reaction a student was provided with 0.1M sulphuric acid solution labeled. (M.A) and a carbonate solution containing 13.8g/cm³ labeled (X.A). The student was required to calculate the formula mass of X₂CO₃ and atomic mass of x in the carbonate. She pipette 25 cm³ of XA and titrated against (MA) using methyl orange indicator, her results of the titration are shown in the table below.

Experiment	1	2	3
Final burette readings in cm ³	25.0	25.0	25.0
Initial burette readings in cm ³	0.00	0.0	0.0
Volume of solution MA cm ³			

- (i) Complete the table (2 mks)
- (ii) What is the average volume of MA used (1 mk)
- (iii) Calculate
- (a) Moles of acid used
- (b) Moles of carbonate used
- (iv) Calculate the molarity of the carbonate (2 mks)

(v) Calculate the formula mass of X_2CO_3 (2 mks)

(vi) Calculate the Ram of x (2 mks)

27. Excess Co gas was passed over heated sample of oxide of iron as shown in the diagram. Study the information and answer the questions that follows:

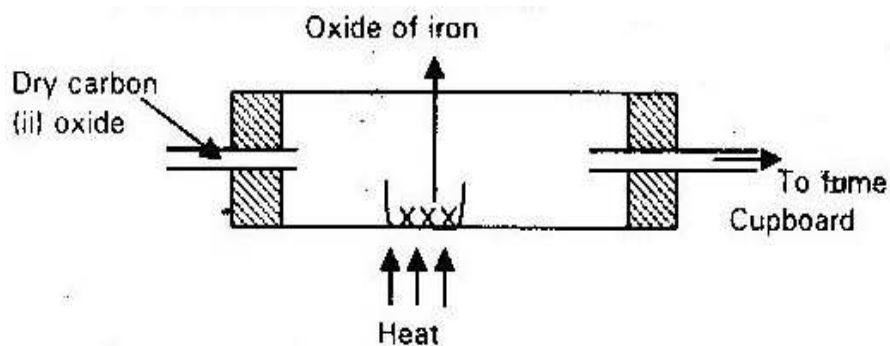

Mass of empty dish = 10.98g

Mass of empty dish + oxide of iron = 13.30g

Mass of empty dish + residue = 12.66g

(i) Determine the formula of the oxide of iron. (RMM of oxide of iron = 232)

Fe = 56) (O=16) (3 mks)

(ii) Write an equation for the reaction taking place (1 mk)

28. 12.5 cm^3 of solution containing $13.8\text{g}/\text{cm}^3$ of carbonate M_2CO_3 required 12.3 cm^3 of H_2SO_4 containing $9.8\text{g}/\text{dm}^3$ for complete neutralization.

(a) Write the equation for the above reaction (1 mk)

(b) Calculate the molarity of the acid (2 mks)

(c) Calculate the molarity of the carbonate (2 mks)

(d) Calculate the molar mass of the carbonate (2 mks)

(e) Find the relative atomic mass of M (2 mks)

29. Calculate the mass of lead (ii) nitrate that must be heated to give 22.3g of lead (ii) oxide (Pb = 207) (M = 14) (O = 16) (3 mks)

30. Solution "A" is NaOH containing 48g/dm^3 . Solution "B" is $(\text{CooH})_z \cdot n\text{H}_2\text{O}$ containing 63g/dm^3 . 20cm^3 of solution "A" was pipetted into a conical flask and titrated with solution "B". The titration was done three times. The results are shown in table below. The equation for the reaction is:

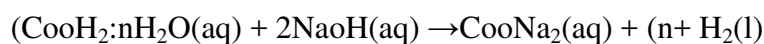

Experiment	1	1	3
Final readings	24.1	24.1	49.0
Initial readings	0.0	0.0	25.0
Volume used	24.1	24.1	24.0

Find

(i) The average volume of solution "B" used (1 mk)

(ii) The moles of solution "A" in 20 cm^3 of solution (1 mk)

(iii) The number of moles of "B" in dm^3 of the solution (1 mk)

(iv) The formula mass of $(\text{CooH})_z \cdot n\text{H}_2\text{O}$ (2mks)

(v) Value of n (1 mk)

(C= 12) (O= 16 (H= 1)

31. Calculate the volume of carbon (iv) oxide measured at S.T.P that is evolved when 1 mole of copper (II) carbonate is heated to a constant mass.

32. How many molecules are there in 360 cm^3 of nitrogen at r.t.p

33. Define the following terms

- (a) Monatomic gas
- (b) Diatomic gas
- (c) Atomicity of an element

TOPIC 3

ORGANIC CHEMISTRY 1

1.

Propane and chlorine react as shown below

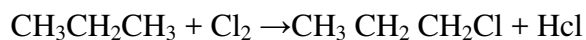

(a) Name the type of reaction that takes place (1 mk)

(b) State the conditions under which this reaction takes place (1 mk)

2.

(a) Name one substance used for vulcanization of rubber (1 mk)

(b) Why is it necessary to vulcanize natural rubber before use (1 mk)

3.

$\text{R}-\text{COO}^- \text{Na}^+$ and $\text{R}-\text{C}_6\text{H}_5\text{SO}_3^- \text{Na}^+$ represents two cleaning agents where "R" is a long hydrocarbon chain.

(a) Write the formula of the salts that would be formed when each of those cleaning agents is added to water containing calcium ions (2 mks)

(b) Explain how the solubility of the two calcium salts (a) above effect the cleaning properties of each of the cleaning agents. (2 mks)

4.

The general formula for a homologous series of organic compound is

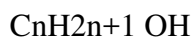

(a) Give the name and structural formula of the fourth member of this series

(1 mk)

(b) Write an equation for the complete combustion of the fourth member of this series

(1 mk)

5.

(a) Name one natural fibre (1 mk)

(b) Give one advantage of synthetic fibres over natural fibre (1 mk)

6.

Study the table below and answer the questions that follow

Alkanes	Formula	Heat of combustion (DHC) kJ mol ⁻¹
Methane	CH ₄	-890
Ethane	C ₂ H ₆	-1560
Propane	C ₃ H ₈	-2220
Butane	C ₄ H ₁₀	-

(a) Predict the heat of combustion of butane and write it in the space provided in the table above (1 mk)

(b) What does the sign ΔH_c value- indicated about combustion of alkanes (1mk)

A compound $C_4H_{10}O$ is oxidized by excess acidified potassium permanganate to form another compound $C_4H_8O_2$. The same compound $C_4H_{10}O$ react with potassium to produce hydrogen gas

(a) Draw the structural formula and name compound $C_4H_{10}O$ (2 mks)

(b) Write equation for the reaction between potassium and compound $C_4H_{10}O$
(1 mk)

6.

Explain how sample of CH_3CH_2OH could be distinguished from CH_3COOH by means of chemical reaction. (2 mks)

7.

Methane react with oxygen as shown by equation I and II below

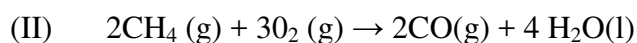
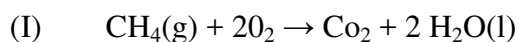

Which one of the two reactions represents the complete combustion of methane?

Explain (2 mks)

8. A polymer has the following structure

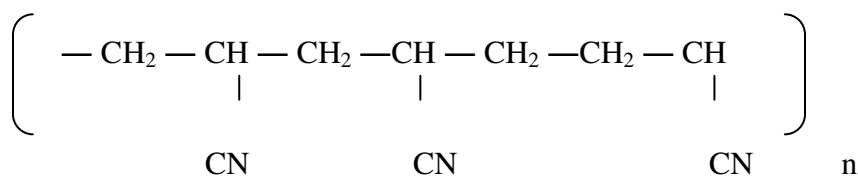

A sample of this polymer is found to have a molecular mass of 5194. Determine the number of monomers in the polymer. (H= 1.0), (C= 12.0), (N= 14, 0)

(3 mks)

9.

A mixture of pentane and pentanoic acid was shaken with 0.1m sodium hydroxide solution. And let to separate as shown in the diagram below.

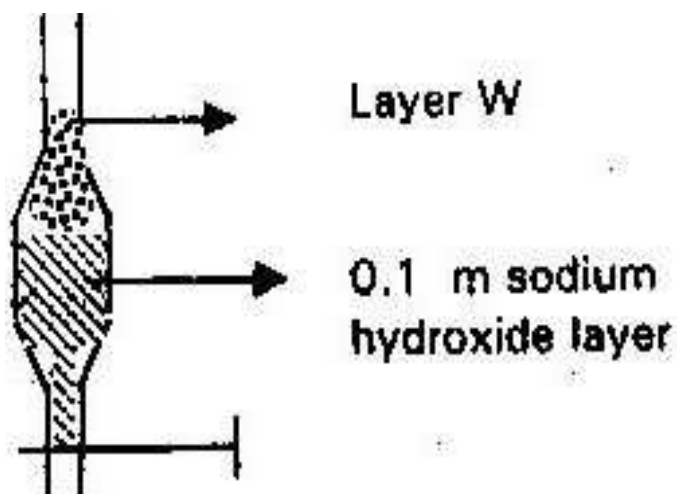

Name the main component in layer W. Give a reason for your answer

(2 mks)

10.

Name and draw the structure of the compound formed when methane react with excess chlorine in presence of U.V light

(1 mk)

14.

Bromine react with ethane as shown below

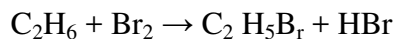

- (a) What condition is necessary for this reaction to occur (1 mk)
- (b) Identify the bonds, which are broken and those which are formed
(2 mks)

15.

A hydrocarbon “p” was formed to decolorize bromine water. On complete combustion of 2 moles of “P” 6 moles of carbon (IV) oxide and 6 moles of water were formed

- (a) Write the structural formula of “p” (1 mk)
- (b) Give the name of p (1 mk)
- (c) Name one industrial source of “p” (1 mk)

16. Pentane and ethanol are miscible. Describe how water could be used to separate a mixture of pentane and ethanol. (2 mks)

17.

In the presence of U.V light ethane gas undergoes substitution reaction with chlorine.

- (a) What is meant by the term substitution reaction with chlorine?

- (b) Give the structural formula and the name of the organic compound formed when equal volumes of ethane and chlorine react together.

18.

But – 2- ene undergoes additional hydrogenation according to the equation given below

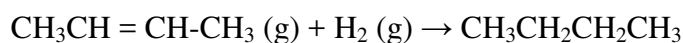

- (a) Name the product formed when but -2-ene reacts with hydrogen gas
(b) State one industrial use of hydrogenation (1 mk)

19.

Name the organic compound formed when $\text{CH}_3\text{CH}_2\text{CH}_2\text{OH}$ is reacted with concentrated sulphuric acid at 170°C . (1 mk)

20.

- (a) What is meant by isomerism? (1 mk)
(b) Draw and name two isomers of butane (2 mks)

- (b) Propane can be changed into methane and ethane as shown in the equation below.



Name the $\xrightarrow{\hspace{2cm}}$ process undergone by propane (1 mk)

21.

The relative formula mass of hydrogen is 58. Draw and name two possible structure of the hydrocarbon (C= 12.0; H= 1.0) (3 mks)

22.

The structure of a detergent is

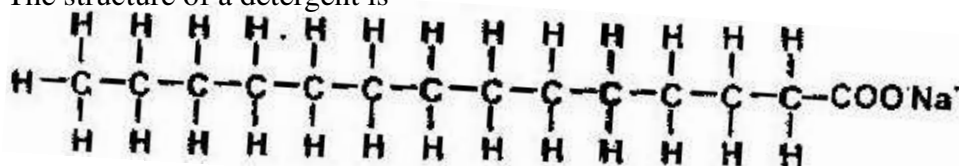

- (a) Write the molecular formula of the detergent (1 mk)
- (b) What type of detergent is represented by the formula? (1 mk)
- (c) When this type of detergent is used to wash linen in hard water, spots (marks) are left on the linen. Write the formula of the substance responsible for the spots (1 mk)

23.

The structure below represents a sweet smelling compound

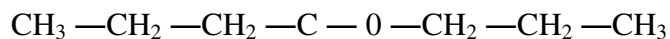

Give the names of the two organic compounds that can be used to prepare this compound in the laboratory. (2 mks)

24.

Study the table below and answer the questions that follow:

Compounds	Melting point $^{\circ}\text{C}$	Boiling points $^{\circ}\text{C}$
$\text{C}_2\text{H}_4\text{O}_2$	16.6	118
C_3H_6	-185.0	-47.7
$\text{C}_3\text{H}_8\text{O}$	-127	97.2
C_5H_{12}	-130	36.3
C_6H_{14}	-95.3	68.7

- (a) (i) Which of the compounds is a solid at 10.00°C . Explain (1 mk)
- (ii) Choose two compounds which are members of the same homologous series and explain the difference in their melting points (3 mks)
- (iii) The compound $\text{C}_3\text{H}_8\text{O}$ is an alcohol. How does its solubility in water differ from the solubility of C_5H_{12} in water. Explain (2 mks)
- (b) Complete combustion of one mole of a hydrocarbon produces four moles of carbon (IV) oxide and four moles of water.
- (i) Write the formula of the hydrocarbon (1 mk)
- (ii) Write the equation for the complete combustion (1 mk)
- (c) (i) In a reaction, an alcohol "J" was converted to hex -1-ene. Give the structural formula of alcohol "J" (1 mk)

(ii) Name the reagent and conditions necessary for the reaction in C

(ii) above (1 mk)

(d) Compound K reacts with sodium hydroxide as shown below



|

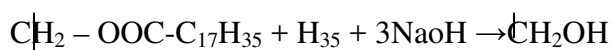

|

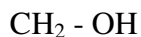
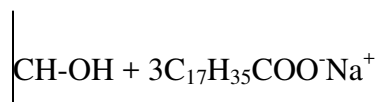

(i) What type of reaction is represented by the equation above (1 mk)

(ii) To what class of compound does “K” belong? (1 mk)

25.

(a) Give the names of the following compounds

(i) $\text{CH}_3\text{CH}_2\text{CH}_2\text{CH}_2\text{OH}$ (1 mk)

(ii) $\text{CH}_3\text{CH}_2\text{COOH}$ (1 mk)

(iii) $\text{CH}_3\text{-COO-CH}_2\text{-CH}_3$ (1 mk)

(b) Study the information in the table below and answer the questions that follow

Number of carbon atoms per molecule	Relative molecular mass of hydrocarbons
2	28
3	42
4	56

- (i) Write the general formula of the hydrocarbons in the table (1 mk)
- (ii) Predict relative molecular formula mass of hydrocarbon with 5 carbon atoms
- (iii) Determine the molecular formula of the hydrocarbon in (ii) above and draw its structural formula. (H=1.0), (C= 12.0) (1 mk)

26.

The following equations represent two different types of reactions

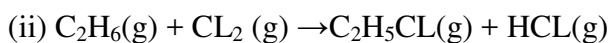
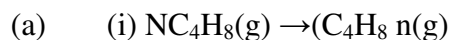

State the type of reaction represented by (i) and (ii) (2 mks)

- (b) The fermentation of glucose produces ethanol as shown in the equation below.

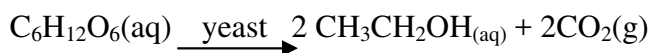

- (i) State how the concentration of ethanol produced could be increased (1 mk)

- (ii) State and explain the observations that would be made when a piece of sodium metal is added to a sample of ethanol contained in a beaker. (2 mks)
- (iii) Give two commercial uses of ethanol other than manufacturing of alcohol drinks (2 mks)
- (c) The molecular formula of a hydrocarbon is C_6H_{14} . The hydrocarbon can be converted into two other hydrocarbons as shown by the equation below.

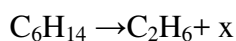

- (i) Name and draw the possible structural formula of x (1 mk)
- (ii) State and explain the observations that would be made if a few drops of bromine water were added to a sample of x. (2mks)
- (iii) Write an equation for the complete combustion of C_3H_8 (1 mk)

27.

(a) Give the names of the following compounds



(b) Ethane and Ethene react with bromine according to the following equations given below

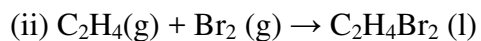
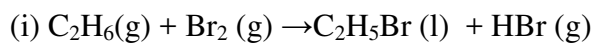

Name the type of bromination reaction taking place in (i) and (ii) above

(c) Study the diagram below and answer the questions that follow

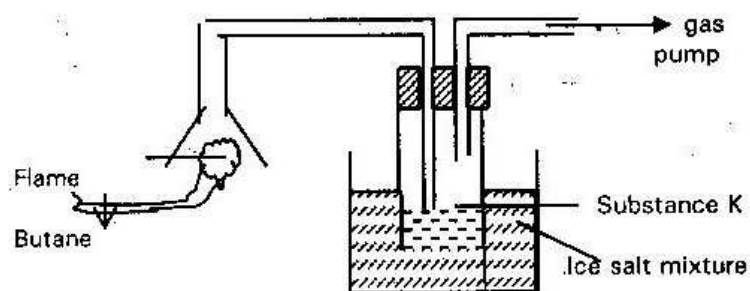

(i) Write the equation for the complete combustion of butane (1 mk)

(ii) The PH of substance K was formed to be less than 7 explain this observations. (2 mks)

(d) The polymerization of tetrafluoroethane (C_2F_4) is similar to that of ethane (C_2H_4)

(i) What is meant by the term polymerization? (1 mk)

(ii) Draw the structural formula of a portion of the polymer obtained from the monomers (C_2F_4) (1 mk)

(e) State any two advantages that synthetic polymers have over natural polymers (2 mks)

28.

(a) In which homologous series do the following compounds belong?

(i) CH_3CCH (1 mk)

(ii) $\text{CH}_3\text{CH}_2\text{COOH}$ (1 mk)

(b) Raw rubber is heated with sulphur in manufacture of natural rubber.

(i) What name is given to the process? (1 mk)

(ii) Why is the process necessary? (1 mk)

(c) Study the scheme given and answer the questions that follow

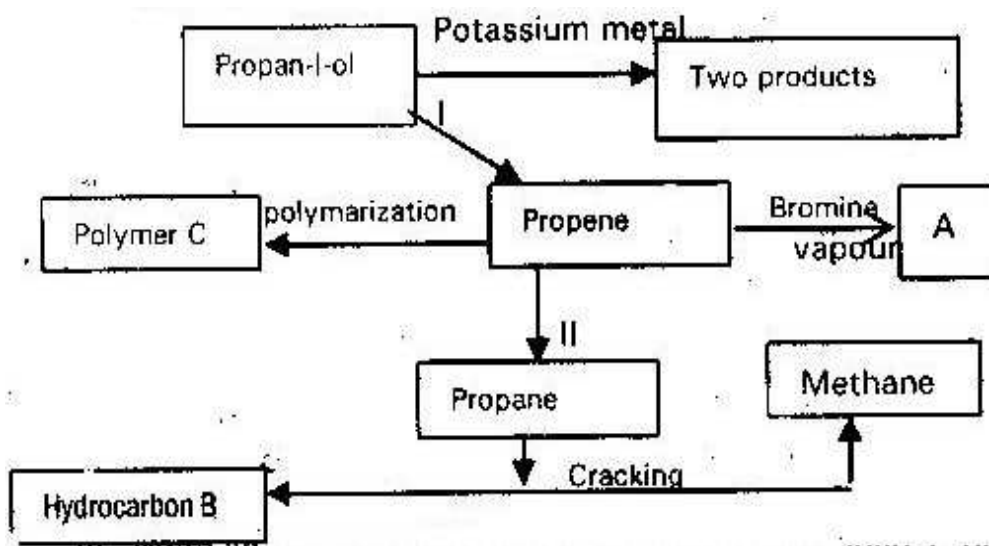

(i) Write an equation for the reaction between propan-1-ol and potassium metal (1mk)

(ii) Name process I and II (2 mks)

(iii) Identify the products "A" and "B" (2 mks)

(iv) Name ONE catalyst used in process II (1 mk)

- (v) Draw the structural formula of the repeating unit in the polymer "C"
- (d) State two industrial uses of methane (2 mks)

29.

- (a) State how burning can be used to distinguish between ethane and ethyne.
Explain your answer.
- (b) Draw the structural formula of the third member of the homologous series of the ethyne. (1 mk)
- (c) The flow chart below shows a series of reactions starting with ethanol.
Study it and answer the questions that follow.

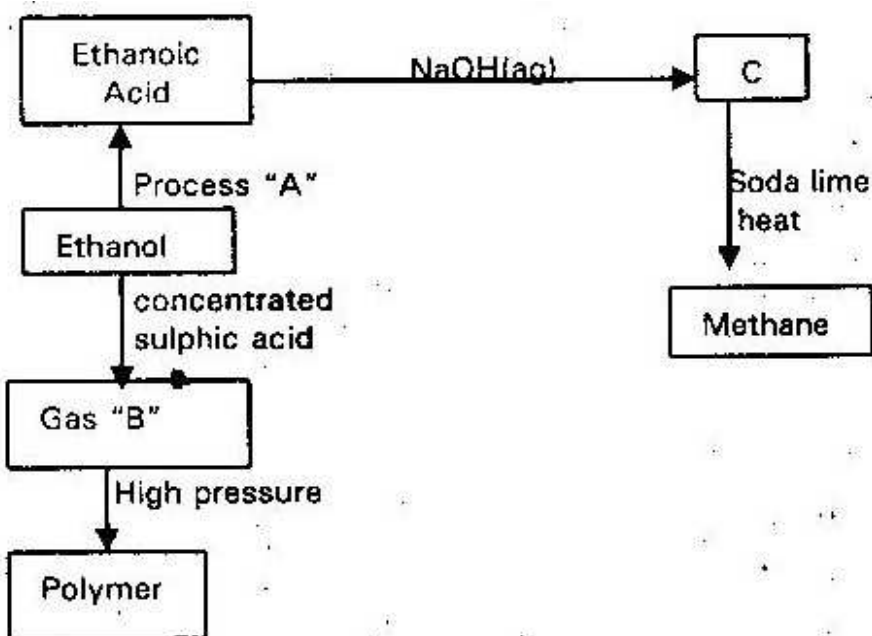

- (i) Name
I Process "A"

II Substance "B" and C

- (ii) Write the equation for the combustion of ethanol. (1 mk)
- (iii) Explain why it is necessary to use high pressure to change gas "B" into polymer (1 mk)
- (iv) State one use of methane (1 mk)

30.

- (a) Crude oil is a source of many compounds that contain carbon and hydrogen only (1 mk)
- (i) Name the process used to separate the components of crude oil (1 mk)
- (ii) On what two physical properties of the above components does the separation depend (2 mks)
- (b) Under certain conditions hexane can be converted to two products. The formula of one of the products is C_3H_8
- (i) Write the formula of the other product (1 mk)
- (ii) Describe a simple chemical reaction to show the differences between two products in b(i) above. (2 mks)
- (c) Ethyne (C_2H_2) is another compound found in crude oil. One mole of ethyne was reacted with one mole of hydrogen chloride gas and a product "P1" was formed. P1 was then reacted with excess hydrogen gas to form P2. Draw the structure of P1 and P2 (2 mks)
- (d) The set up below was used to prepare and collect ethane gas. Study it and answer the questions that follows:

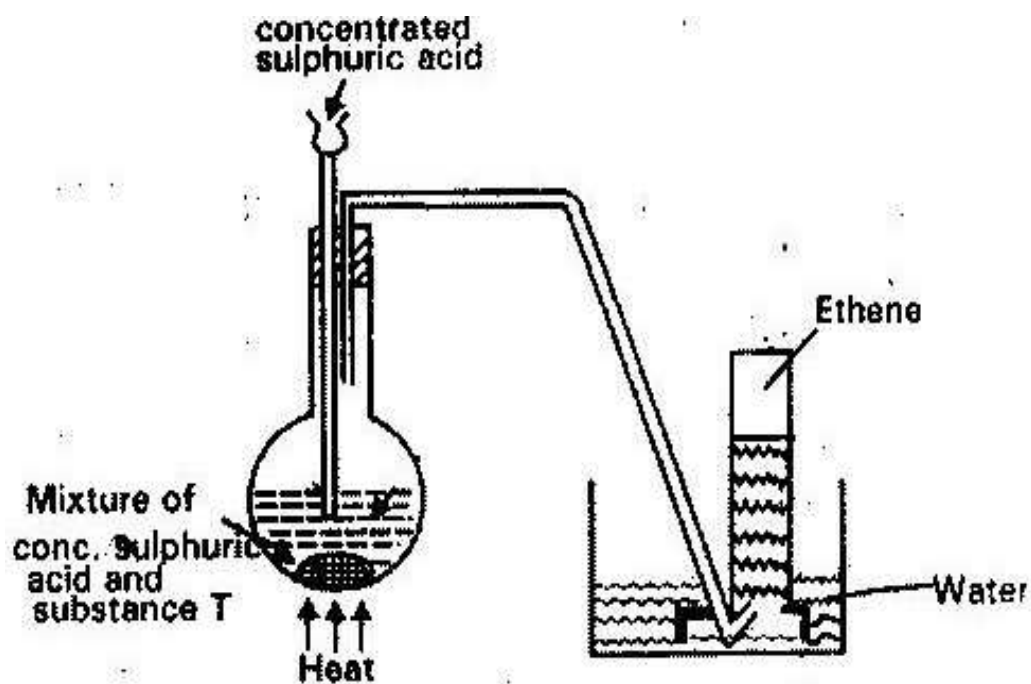

- (i) Name substance "T" (1 mk)
- (ii) Give the property of ethane that follows it to be collected as shown in the set up (1 mk)
- (e) One of the reactions undergone by ethane is addition polymerization. Give the name of the polymer and one disadvantage of the polymer it forms (2 mks)

31.

- (a) What name is given to a compound that contain carbon hydrogen only
- (b) Hexane is a compound that contain carbon and hydrogen only
- (i) What method is used to obtain hexane from crude oil?

(ii) State one use of hexane (1 mks)

(c) Study the flow chart below and answer the questions that follows:

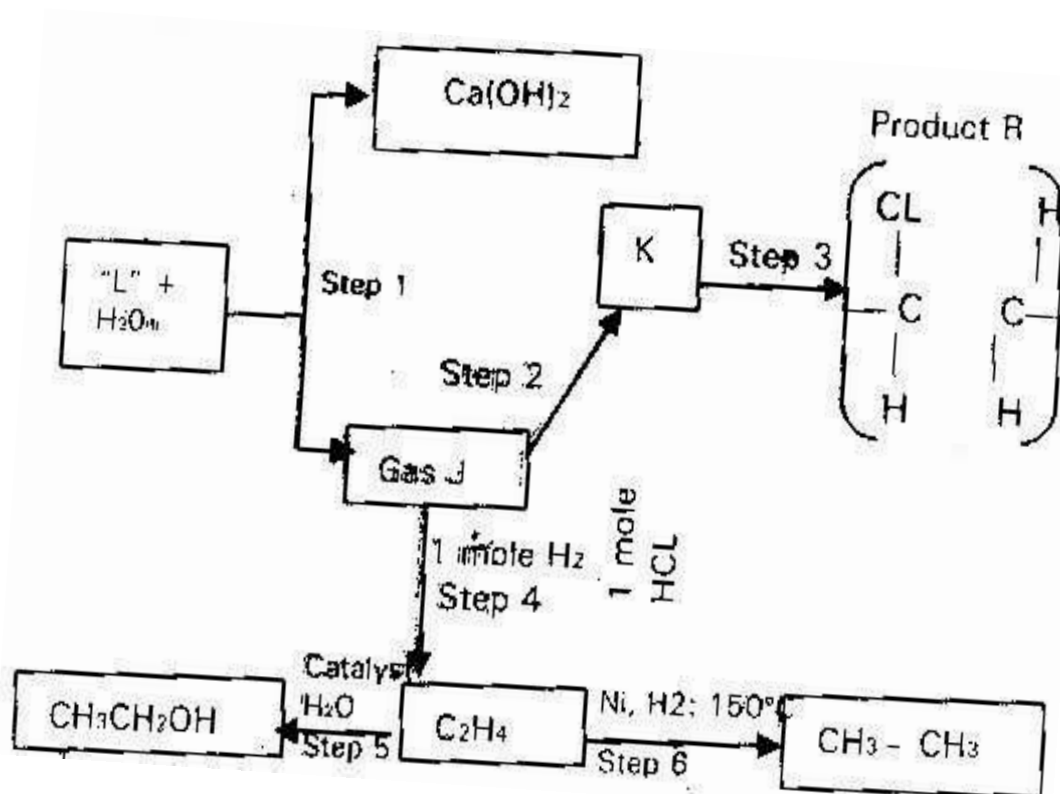

- (i) Identify reagent L (1 mk)
- (ii) Name the catalyst used in step 5 (5 mks)
- (iii) Draw the structural formula of "J" (1 mk)
- (iv) What name is given to the process that takes place in step 5 (½ mk)

- (v) State
- I. One use of product “R”
 - II. A commercial application of the process which take place in step 6
- (d) (i) Write the equation for the reaction between aqueous sodium hydroxide and aqueous ethanoic acid (1 mk)
- (ii) Explain why the reaction between 1g sodium carbonate and 2 m hydrochloric acid is faster than the reaction between 1 g of sodium carbonate and 2 M ethanoic acid (2mks)

32.

- (a) Give the systematic names of the following compounds

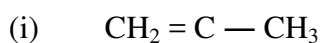

(1 mk)

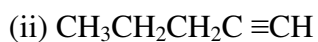

(1 mk)

33.

- (a) Biogas is a mixture of mainly carbon (IV) oxide and methane

- (i) Give a reason why biogas can be used as fuel

- (ii) Other than fractional distillation, describe a method that can be used to determine the percentage of methane in biogas (3 mks)
- (b) A sample of biogas contains 35.2% by mass of methane. A biogas cylinder contains 5.0 kg of the gas.
- (i) Number of moles of methane in the cylinder. (Molar mass of methane = 16) (2 mks)
- (ii) Total volume of carbon (IV) oxide produced by the combustion of methane in the cylinder (molar gas volume = 24.0 dm³ at room temperature and pressure. (2 mks)
- (c) Carbon (IV) oxide, methane, nitrogen(I)oxide and trichlorofluoromethane are green- house gases
- (i) State one effect of an increased level of these gases to the environment (1 mk)
- (ii) Give one source from which each of the following gases is released to the environment
- I Nitrogen (I) oxide (1 mk)
- II Trichlorofluoromethane (1 mk)

34. State what you understand by the following terms as used in organic chemistry

- (i) A hydrocarbon (1 mk)
- (ii) A homologous series (1 mk)
- (iii) Saturated hydrocarbons (1 mk)
- (iv) Isomerism (1 mk)

35. Name the following compounds using the I.U.P.C rules

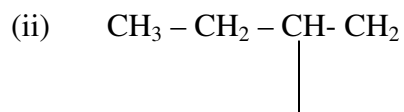

CH_3

36. Below is a scheme of some reaction of ethyne

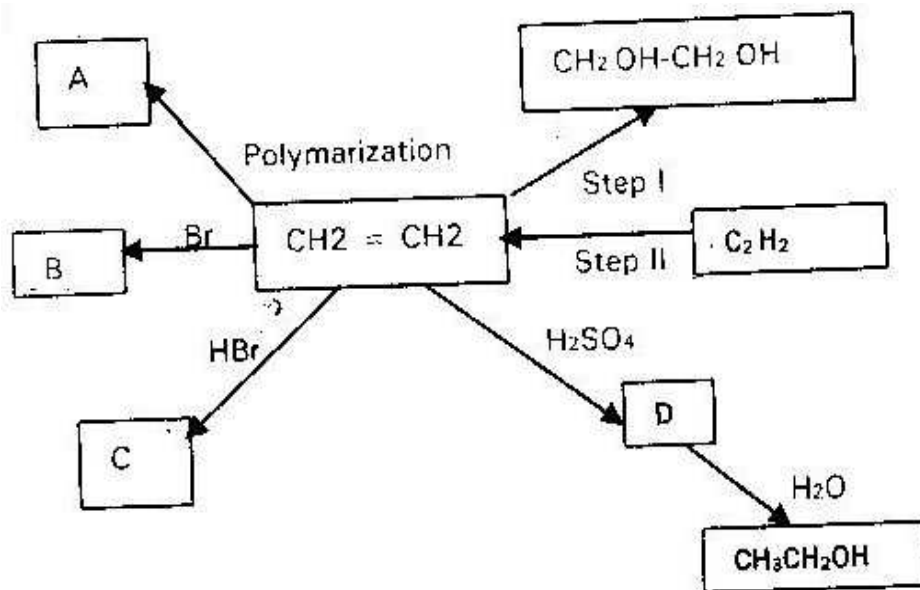

(i) State the condition and reagents required to effect steps I and II (2mks)

(ii) Give the formula of products A, B, C and D (4mks)

37. Write down the structural formula of the following compounds

(i) 2, 2 – Dimethylpropane (1 mk)

(ii) 2 – Chloropropane (1 mk)

38. Study the crude oil fractionating column in the diagram and answer the questions that follows

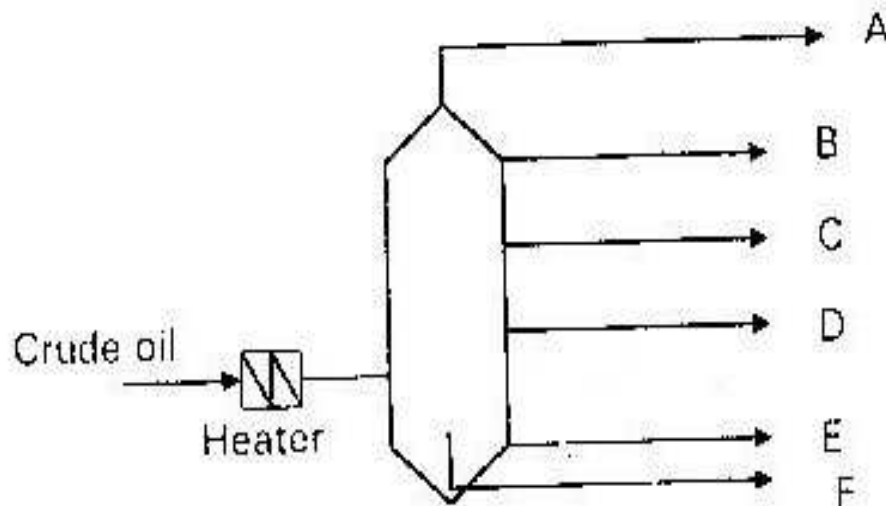

(a) How would you expect the temperature to vary from A to E (2mks)

(b) For each fraction below state at which position it will be collected

compound with (5mks)

- C₁₅- C₂₅ atoms

- C₄- C₁₂ atoms

- C₂₀ – upwards

- C₉- C₁₆

- C₁ – C₄

39. The boiling points at 760 mm pressure of three alkanes are Butane, 273K, pentane 309K and Hexane 342K. Account for the fact that the pentane has a higher boiling point than butane. (2 mks)

40. Petrol is a mixture of hydrocarbon used as fuel and is obtained from crude oil by fractional distillation.

- (i) State the range of carbon atoms in the molecules of hydrocarbon in petrol
- (ii) Name two gases that pollute the atmosphere as a result of burning petrol in combustion engines (2 mks)

41. What is the role of sunlight in substitution halogenations reaction (1 mk)

42. A,B,C are three homologous series of organic compounds

Series	General formula
A	C_nH_{2n-2}
B	C_nH_{2n}
C	C_nH_{2n+2}

- (i) What is the name given to series C (1 mk)
- (ii) Write down the name and structural formula of the second member of series "B"
- (iii) Write down an equation and name the products of reaction between HBr with second member of series "B" (2 mks)

43. The scheme below shows preparation of methane



- (i) Name reagent "R" (1 mk)
- (ii) Name substance "T" (1 mk)
- (iii) Write an equation for the reaction between CH_3COONa and reagent "R" (2 mk)

44. $\text{CH}_2 = \text{CH}_2$ Polymerize $[-\text{CH}_2 - \text{CH}_2]_n$ compound U

- (i) Name compound U (1 mk)
- (ii) If the RMM of U is 42000 determine the value of n (1 mk)

45. The empirical formula a hydrocarbon is C_2H_3 it RMM is 54.

- (a) Determine the molecular of the hydrocarbon (1 mk)
- (b) Draw the structural formula of this hydrocarbon (1 mk)
- (c) To which homologous series does the hydrocarbon draw above belong? (1 mk)

TOPIC 4

NITROGEN AND ITS COMPOUNDS

1.

A student set- up apparatus to prepare and collect a sample of ammonia gas as shown in the diagram below. Study the set up and answer the question that follows

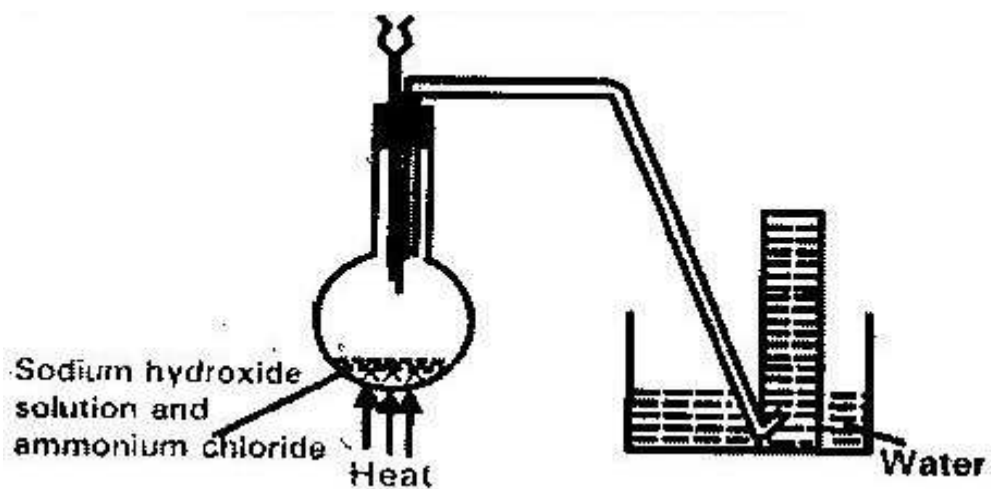

Identify the two mistakes in the set- up represented by the diagram (2 mks)

2.

State two observations that would be made when solid lead (II) Nitrate is heated strongly. (2 mks)

3.

Dilute nitric acid reacts with copper according to the equation

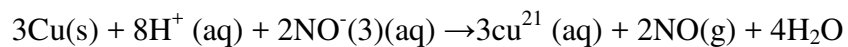

- (a) What is the oxidation number of nitrogen in NO_3^- and NO ? (2 mks)
- (b) With respect to nitrogen, explain whether the above reaction is an oxidation or a reducing process. (1 mk)

4.

On strong heating, sodium nitrate liberates oxygen gas, draw a labeled diagram of set up that could be used for heating sodium nitrate and collecting the oxygen gas liberated. (3 mks)

5.

Complete the diagram below to show how sample of solution of ammonia can be prepared in the laboratory

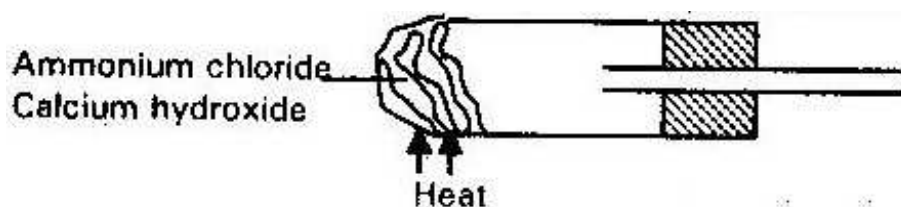

6.



In one process 680 kg of ammonia were reacted with excess carbon (IV) oxide.

Calculate the mass of urea that was formed. (H= 1.0) (C = 12.0) (N= 14.0) (O= 16.0) and relative molecular mass of ammonia = 17 (3 mks)

7.

The scheme below show some reactions sequence starting with solid "N"

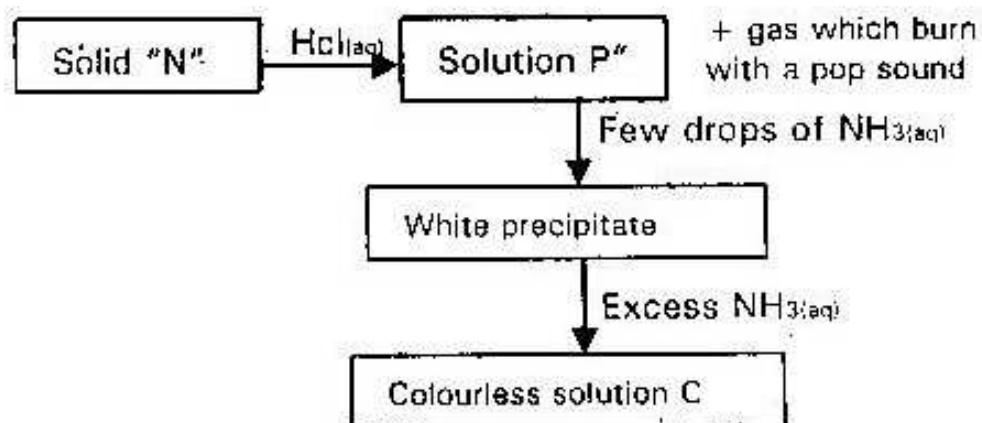

- (a) Identify solid "N" (1 mk)
- (b) Write the formula of the complex ion present in solution C. (1 mk)

8.

A study set up apparatus shown below to prepare ammonia gas and react it with copper (II) sulphate solution

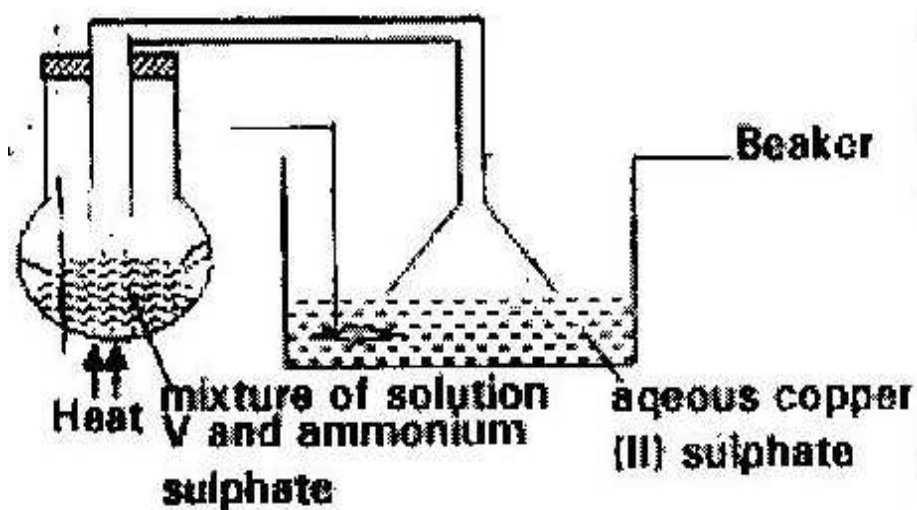

- (a) Identify solution "V" (1 mk)
- (b) State the observation which were made in the beaker (2 mks)

9.

In an experiment, ammonium chloride was heated in a test tube. A moist red litmus was placed in a mouth of the test tube first change to blue then read.

Explain these observations (3 mks)

10.

When potassium nitrate is heated it produce potassium nitrate and gas C_1

- (i) Identify gas C_1
- (ii) Name the type of reaction undergone by potassium nitrate

11. Ammonium nitrate was gently heated and the products collected as shown in the diagram below

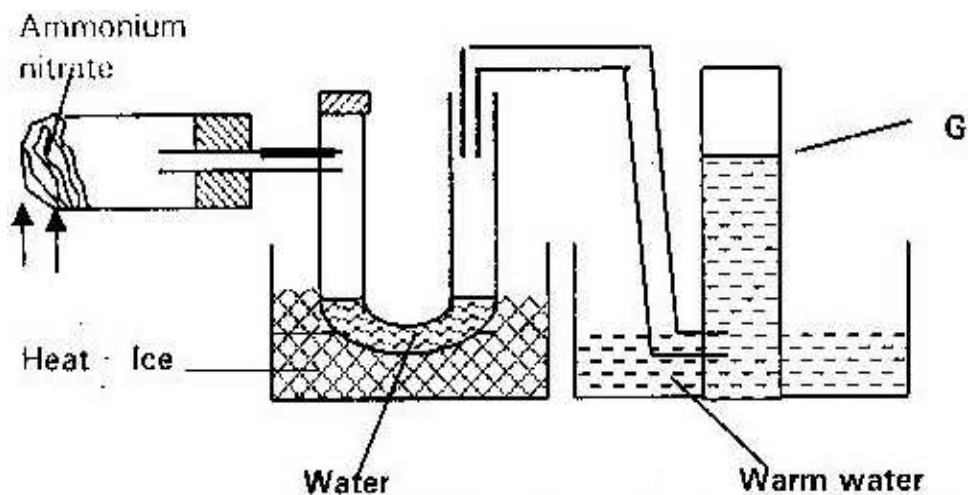

Describe one chemical test and one physical property that can be used to identify gas G. (3 mks)

12.

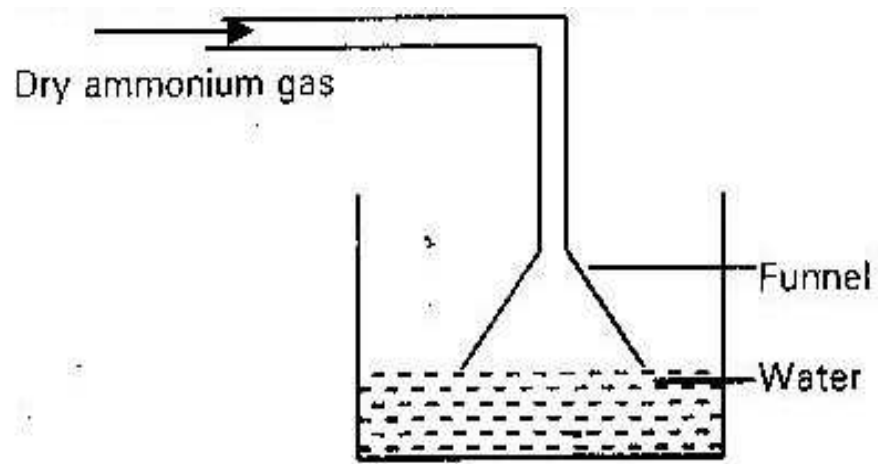

- (a) When a red litmus paper was dropped into the resulting solution. It turns blue, give a reason for this observations (1 mk)
- (b) What is the function of the funnel?

13.

When ammonium Nitrate is heated in the set up below a colourless gas “A” is produced

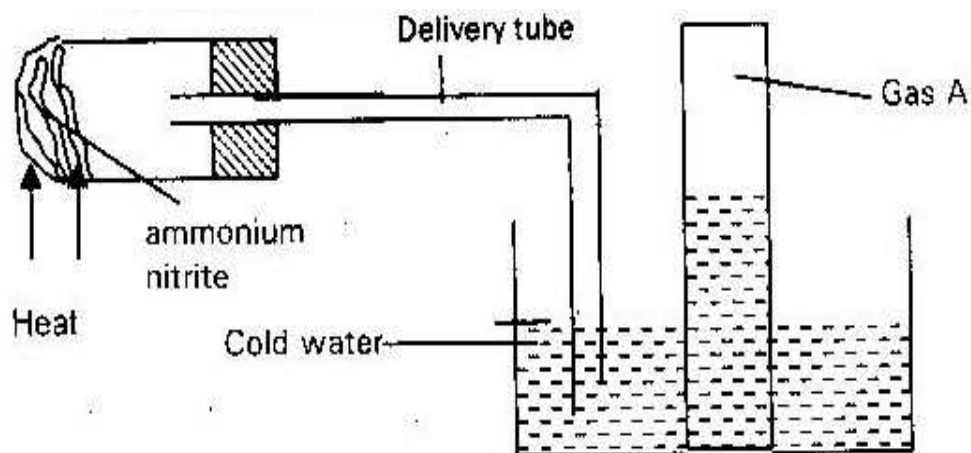

- (i) Identify gas “A”
- (ii) State and explain the precautions that must be taken before heating is stopped (2 mks)

14.

The diagram below shows a set up that was used to prepare and collect a sample of nitric acid in the laboratory

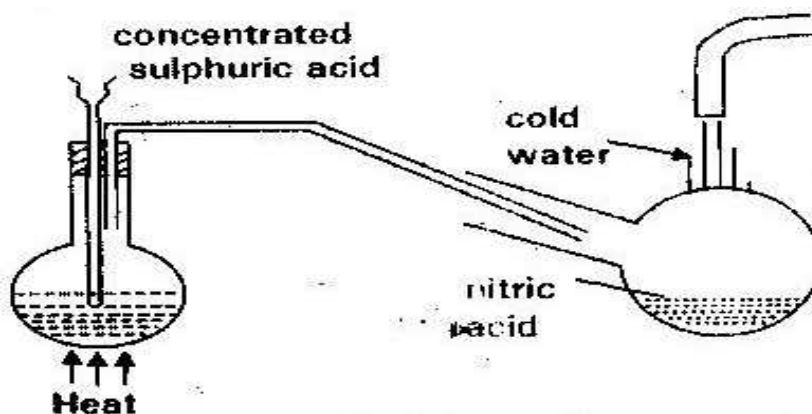

- (a) Give a reason why it is possible to separate nitric acid from the sulphuric acid in the set up (1 mk)
- (b) Name another substance that can be used instead of potassium nitrate (1 mk)
- (c) Give one use of nitric acid (1 mk)

15.

The first step in the industrial manufacture of nitric acid is the catalytic oxidation of ammonia gas

- (a) What is the name of the catalyst used (1 mk)
- (b) Write the equation for the catalytic oxidation of ammonia gas (1 mk)
- (c) Nitric acid is used to make ammonium nitrate. State uses of ammonium nitrate (1 mk)

16.

State and explain the observation made when excess ammonia gas reacts with chlorine gas (3 mks)

17. When magnesium was burnt in air, a solid mixture was formed. On addition of water to the mixture a gas which turned moist red litmus paper blue was evolved. Explain these observations. (2 mks)

18.

In an experiment, ammonia gas was prepared by heating ammonium salt with an alkali. After drying 120 cm³ of ammonia gas was collected at room temperature

and pressure. All the ammonia gas was then reacted completely with 250 cm³ solution of phosphoric acid.

- (a) What is meant by the term alkali? (1 mk)
- (b) Explain using the physical properties of the gas, why ammonia is not collected
- (i) Over water (1 mk)
- (ii) By downward delivery (1 mk)
- (c) Ammonia turns wet red litmus paper blue. Which ions are responsible for this reaction? (1 mk)
- (d) Calculate the number of moles of ammonia gas that were collected in the above experiment given that one mole of gas occupied a volume of 24000cm³ at room temperature and pressure (3 mks)
- (e) The equation below shows the reaction between ammonia and phosphoric acid.

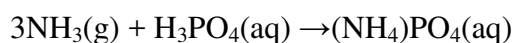

- (i) Explain how crystals of ammonium phosphate could be obtained in this experiment (2 mks)
- (ii) Calculate the maximum mass of ammonium phosphate that could be obtained in this experiment (2 mks)
- (N= 14.0) (O= 16.0) (P = 31.0) (H= 1.0)

19.

- (a) The diagram below shows a set up that can be used to obtain nitrogen gas in an experiment

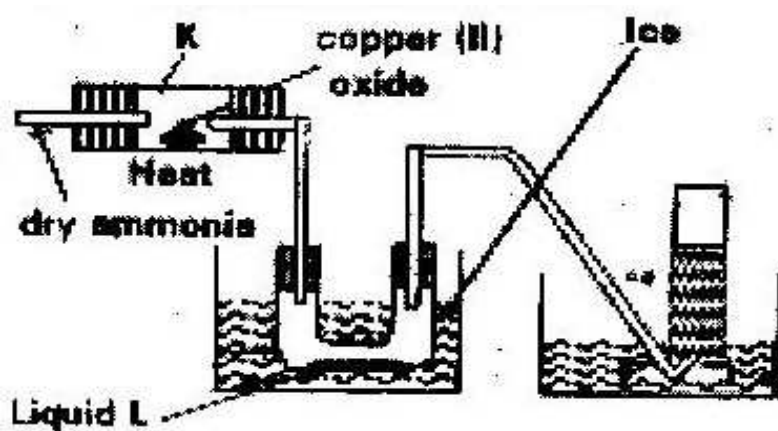

- (i) Name liquid "L" (1 mk)
- (ii) What observations would be made in tube "K" after heating for some time (1 mk)
- (iii) Write an equation for the reaction that took place in tube "k" (1 mk)
- (iv) If 320 cm^3 of ammonia gas reacted completely with copper (II) oxide calculate
- (i) The volume of nitrogen gas produced (1 mk)
- (ii) The mass of copper oxide that reacted (3 mks)
- (iii) At the end of the experiment, the pH of the water in the beaker was found to be 10: Explain (2 mks)

- (b) In another experiment a gas jar, containing ammonia was inverted over a burning splint. What observations would be made? (1 mk)

20. a) The diagram below represents a set up used to obtain nitrogen from air.

Study and answer the questions that follow

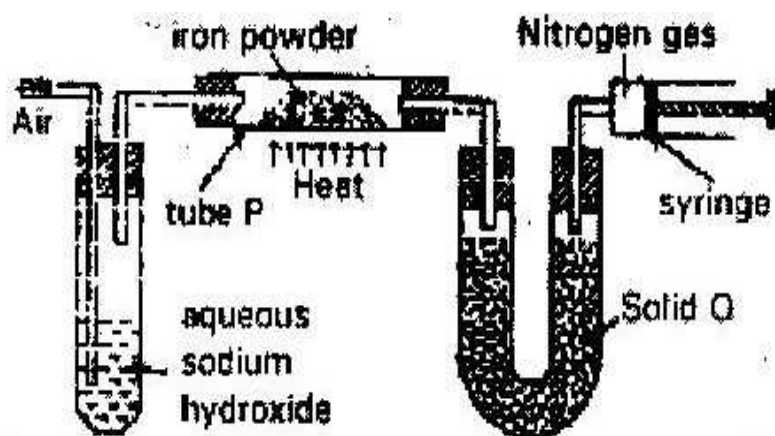

- (i) Name solid Q (1 mk)
- (ii) What is the purpose of sodium hydroxide (1 mk)
- (iii) Write an equation for the reaction which took place in tube "P" (1 mk)
- (iv) Give the name of one impurity in the nitrogen gas obtained (1 mk)
- (v) Give a reason why liquid nitrogen is upside for storage of semen for artificial insemination (1 mk)
- (b) The set up below was used to prepare nitric acid

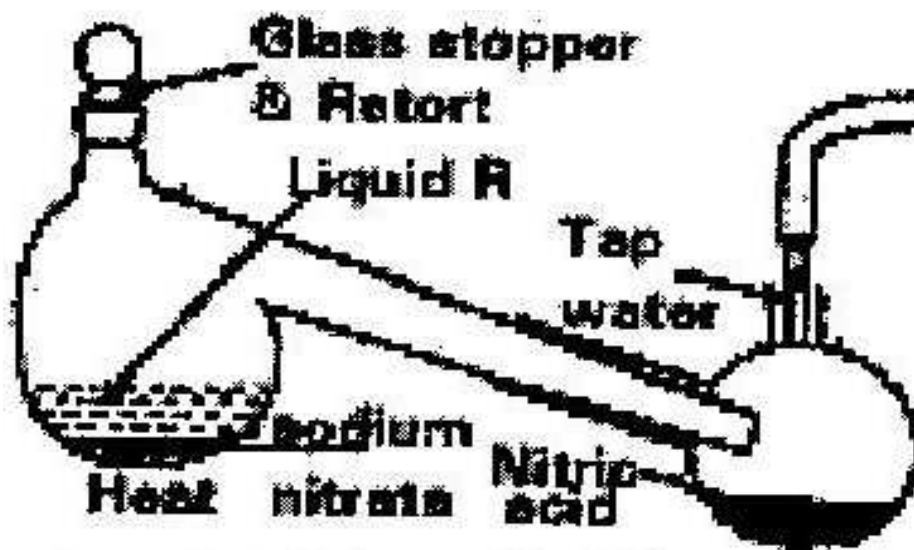

- (i) Give the name of liquid "R" (1 mk)
- (ii) Write an equation for the reaction which took place in the glass retort (1 mk)
- (iii) Explain the following
- (i) Nitric acid is stored in dark bottles (1 mk)
- (ii) The reaction between copper metal with 50% nitric acid in an open tube gives brown fumes (2 mks)
- (c) A factory uses nitric acid and ammonia gas as the only reactant for the preparation of the fertilizer. If the daily production of the fertilizer is 4800 kg, calculate the mass of ammonia gas used daily (N= 14.0), (O = 16.0), (H= 1.0) (3 mks)

21. The flow chart below shows the industrialization of ammonia and the process used in the manufacture of some ammonium compounds. Study it and answer the questions that follow

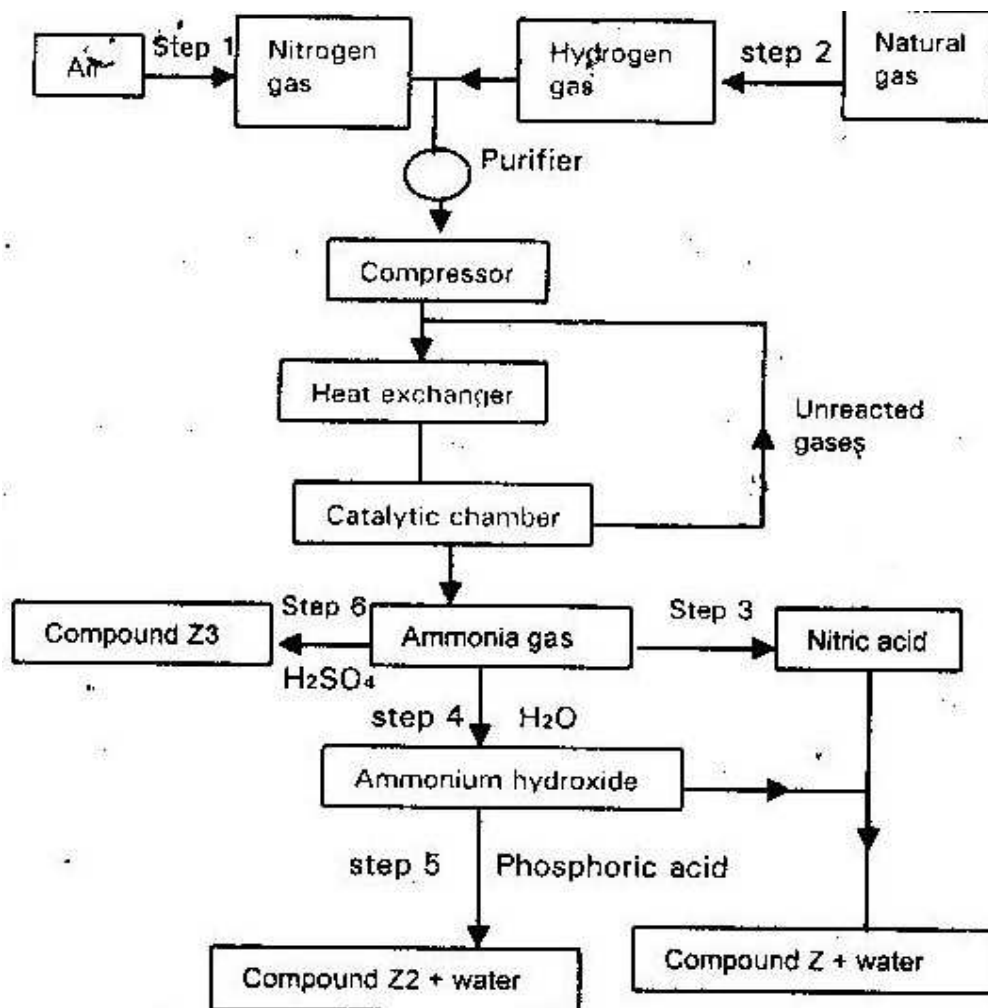

- (a) Give the name of the
- Process in step 1 (1 mk)
 - Reaction that takes place in step 5 (1 mk)
- (b) State one other source of hydrogen gas apart from natural gas (1 mk)
- (c) Explain why it is necessary to compress nitrogen and hydrogen in this process (2 mks)
- (d) Write an equation for the reaction which takes place in step 6 (1 mk)
- (e) Name the catalyst and reagents used in step 3 (2 mks)

(f) Name compound Z_1 (1mk)

(g) Give one commercial use of compound Z_2 (1 mk)

22.

(a) The flow chart below shows some reactions starting with lead (II) nitrate.

Study it and answer the questions that follows.

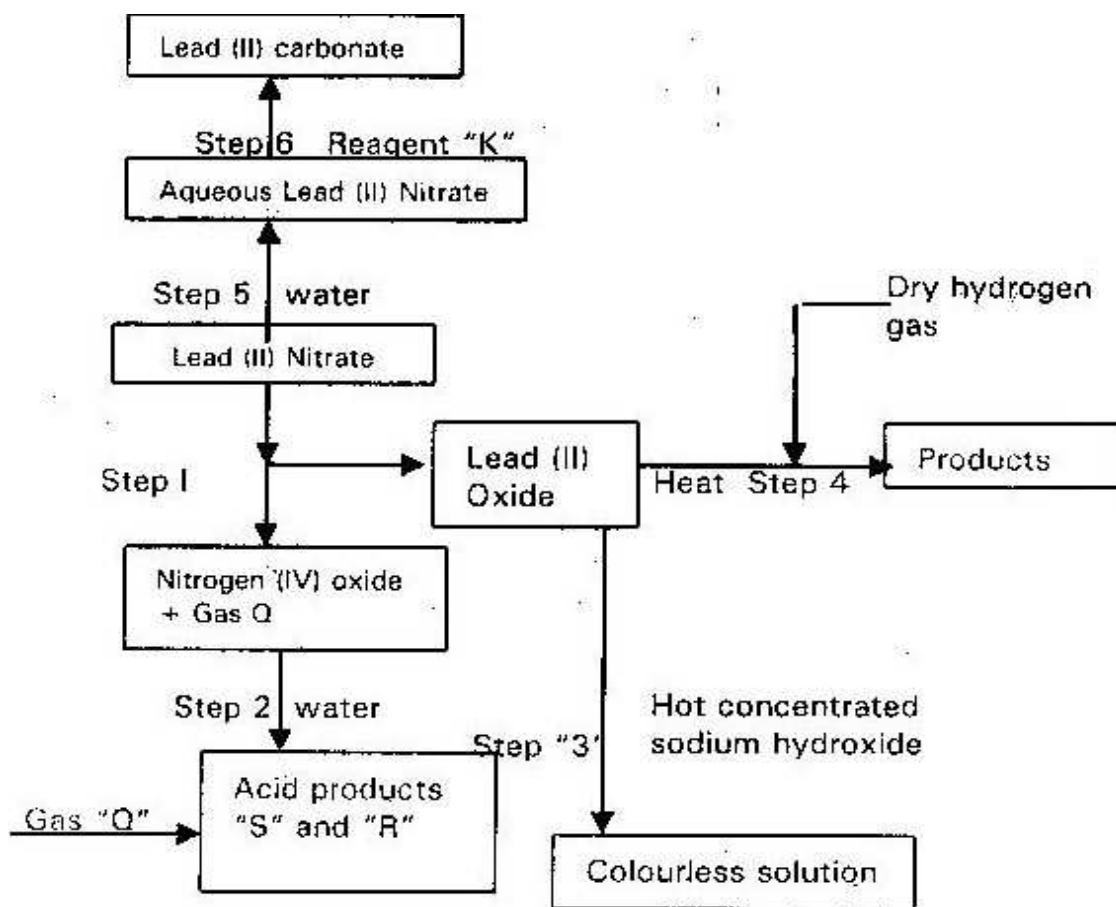

(i) State the conditions necessary in step 1 (1 mk)

I. Identify I: reagent K (1 mk)

II. Gas Q (1 mk)

III. Acid products "S" and "R" (1 mk)

(ii) Write

I. The formula of the complex ion formed in step 3 (1mk)

II. The equation of the reaction in step 4 (1 mk)

(b) The use of materials made of lead in roofing and in water pipes is being discouraged. State

(i) Two reasons why these materials have been used in the past

(ii) One reason why their use is being discouraged (1 mk)

(c) (i) The reaction between lead (II) nitrate and concentrate sulphuric acid starts but stops immediately explain (2 mks)

(ii) Name one suitable reagent that can be reacted with concentrated sulphuric acid to produce nitric acid

23. Write an equation to show the effect of heat on the nitrate of:

(i) Potassium (1 mk)

(ii) Silver (1 mk)

24.

(a) Study the flow chart below and answer the questions that follow

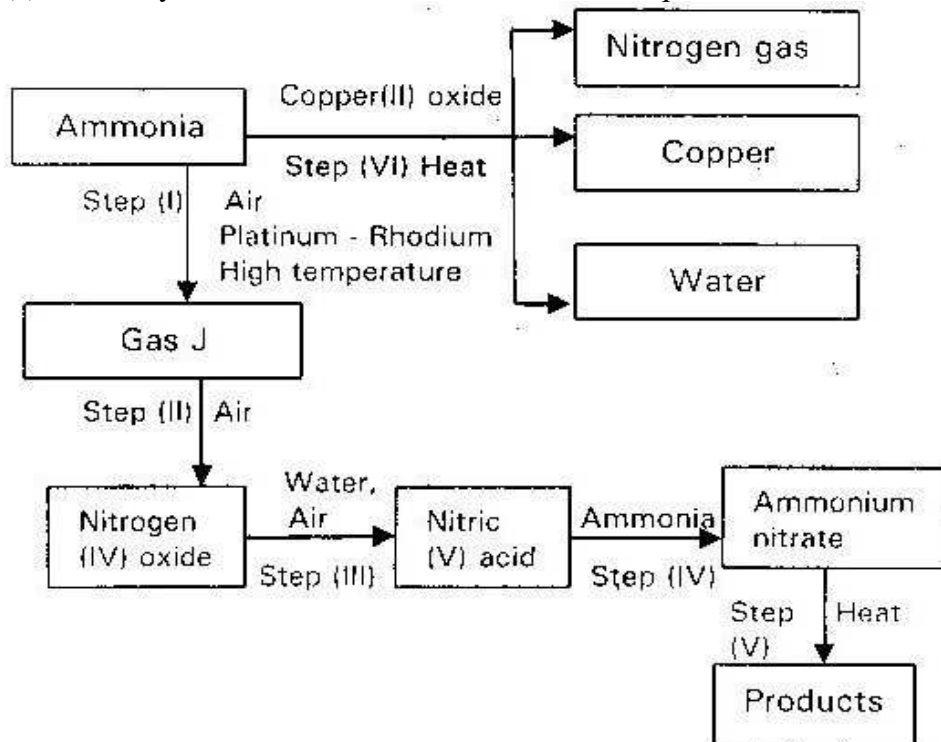

- (i) Identify gas J (1 mk)
- (ii) Using oxidation numbers, show that ammonia is the reducing agent in step (VI) (2 mks)
- (iii) Write the equation for the reaction that occurs in step (V) (1 mk)
- (iv) Give one use of ammonia nitrate (1 mk)

- (b) The table below shows the observations made when aqueous ammonia was added to cations of element E, F, and G until in excess

Cations	Addition of a few drops of aqueous ammonia	Addition of excess aqueous ammonia
E	White precipitate	Insoluble
F	No precipitate	No precipitate
G	White precipitate	Dissolve

- (i) Select the cation that is likely to be Zn^{2+} (1 mk)
- (ii) Given that the formula of the cations of element E is E^{2+} , write the ionic equation for the reaction between $E^{2+}(aq)$ and aqueous ammonia (1 mk)

25. Nitric (Nitric (V) acid is prepared in the laboratory by the action of concentrated acid on a suitable nitrate and distilled off nitric acid. The reaction is carried out in all glass apparatus.

- (i) Why is an all glass apparatus desirable in this preparation? (1 mk)
- (ii) Pure nitric (v) acid is colourless liquid but the product in this preparation is yellowish in colour explain. (imk)
- (iii) How can this yellow colour be removed from the acid. (1 mk)

26. A dry gas X was passed over heat copper (ii) oxide. A brown residue, a colourless liquid “y” and a colourless gas “z” were formed. Gas “z” has no effect on litmus papers and does not support combustion

- (a) Suggest the identities of x, y, z and a colourless liquid (4mks)
- (b) Write an equation for the reaction above.

27. Study the chart below for the large scale production of nitrogen.

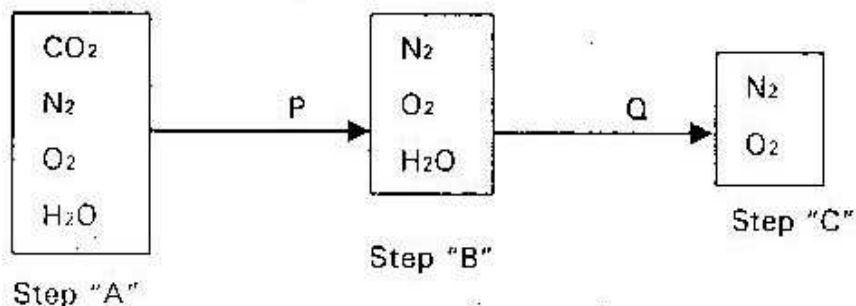

- (a) Explain briefly each of the process P and Q. (2mks)
- (b) How is nitrogen eventually obtained from step "C". (2mks)

28. The following is flow chart representing the manufacture of a fertilizer.

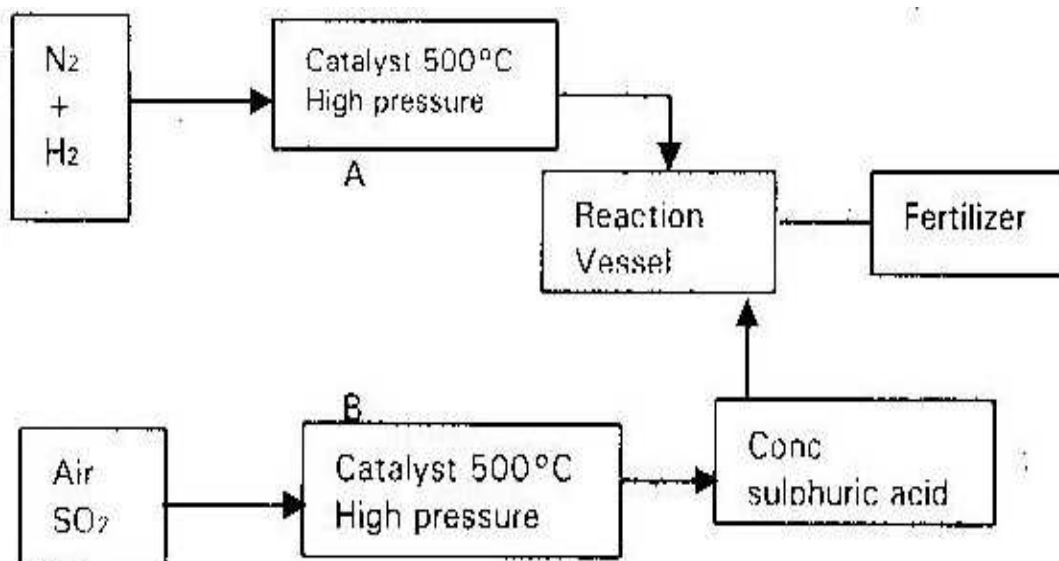

- (i) Write an equation for the reaction in chamber A (1mk)
- (ii) Name the catalyst in chamber "B" (1mk)

29. Study the flow chart below and answer the question that follows.

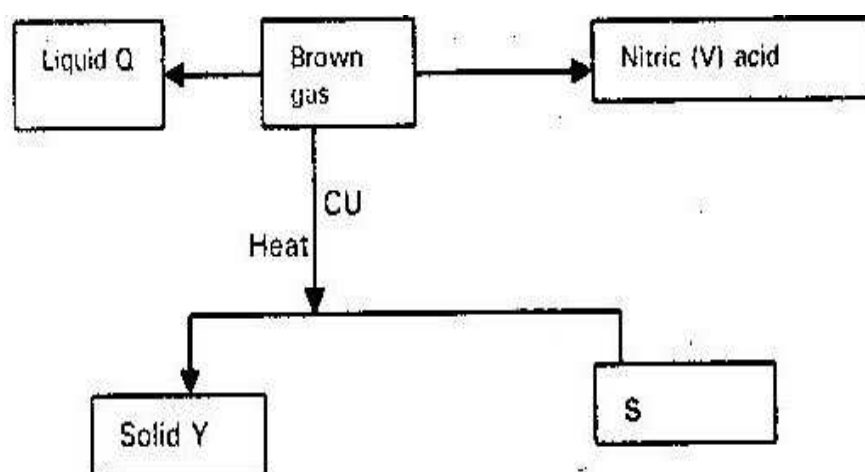

Identify

- (i) Liquid Q
- (ii) Gas x
- (b) Write the equation between the brown gas above and water.

30. Study the apparatus and answer the Questions follow?

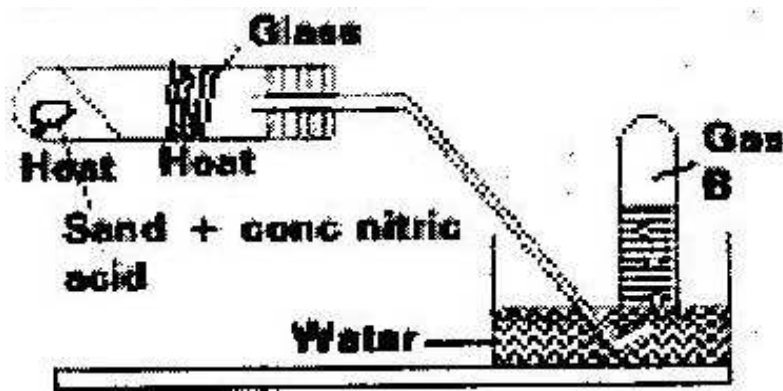

- (a) Why does nitric (v) acid appears yellow? (1mk)
- (b) When strongly heated brown fumes are evolved. What are these fumes (1 mk)
- (c) Give the identity of gas Q and give its test. (1mk)
- (d) State the use of glass wool and the role of sand in the experiment. (2mk)
- (e) Write an equation to show the decomposition of nitric acid when strongly heated (1mk)

31. The diagram below shows an investigation on a property of ammonia gas

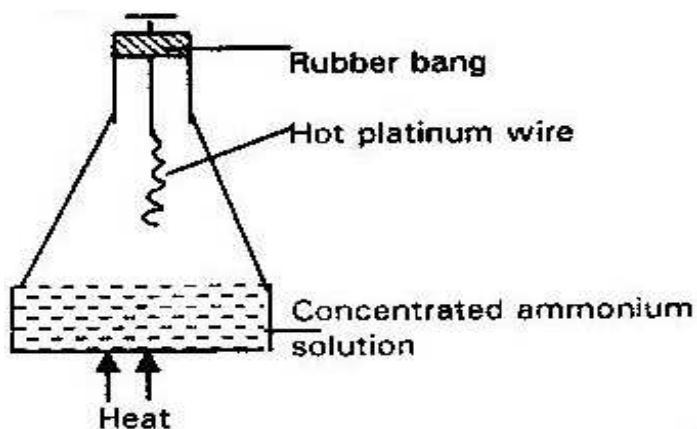

- (a) The platinum wire is observed to glow. Explain the cause of that observation (2 mks)
- (b) State the observations made when the rubber bang is removed. (1mk)

32. The reaction below represents a major reaction in the industrial process.

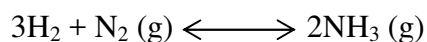

- (a) Name the industrial process (1 mk)
- (b) Name the catalyst used in above process (1 mk)
- (c) Explain the following observations. When ammonia gas mixed with oxygen is sparked over platinum gauze wire, brown fumes are evolved (2 mks)

33. The scheme below shows some reactions starting with salt "P" study it and answer the questions that follows

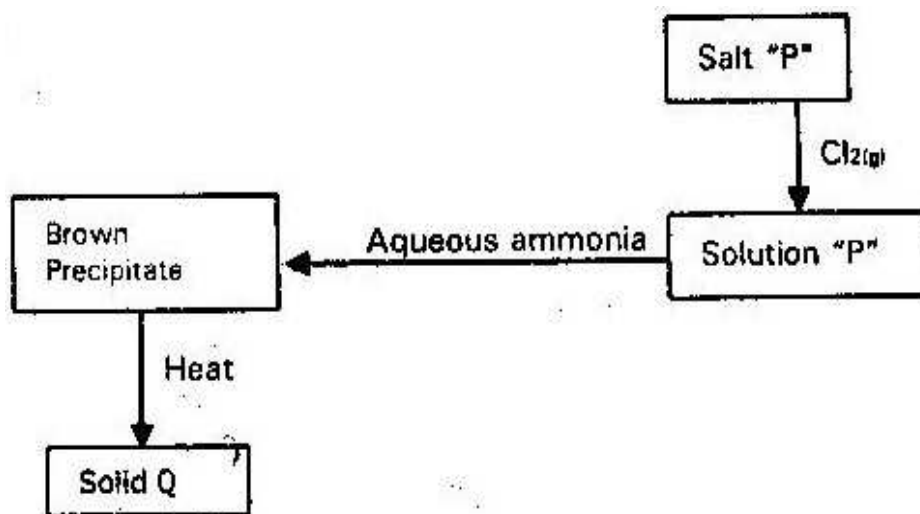

- (a) Which ions are contained in solution "P" (1 mk)
- (b) Write the formula of solid Q and the brown precipitate (2 mks)

(c) Write an equation for the formation of

(i) Brown precipitate

(1 mk)

(ii) Solid Q

34. The flow chart below illustrates the major steps in the manufacture of nitric (v) acid. Study it and answer the question that follows.

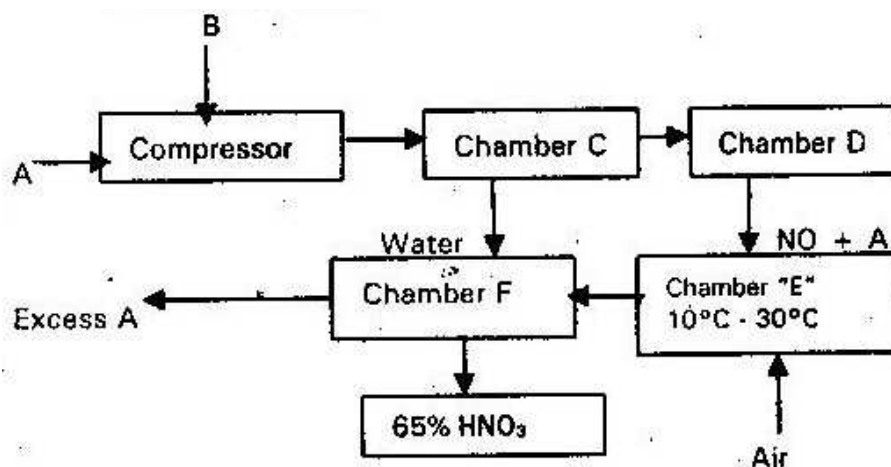

(a) Give reasons for purifying raw material "A" and "B" (1 mk)

(b) Name the substance D, E and F (1 mk)

(c) Name the parts labeled D, E and F (3 mks)

(d) Write chemical equations for the reactions taking place in

(i) Chamber D (1 mk)

(ii) Chamber F (1 mk)

(f) A mixture that comes out is 65% Nitric (V) acid and 35% water. How

could concentration of nitric acid be increased? (1 mk)

- (g) Give one use of Nitric (V) acid
- (h) When copper metal is reacted with concentrated Nitric (V) acid a brown gas is evolved, explain (1 mk)

TOPIC 5

SULPHUR AND ITS COMPOUNDS

1.

Study the flow chart below and answer the questions

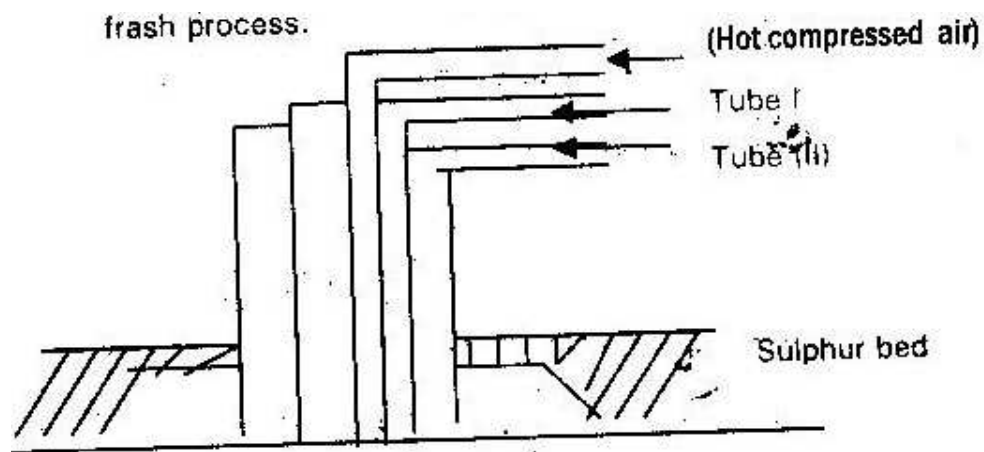

2.

The diagram below represents the extraction of sulphur by frash process

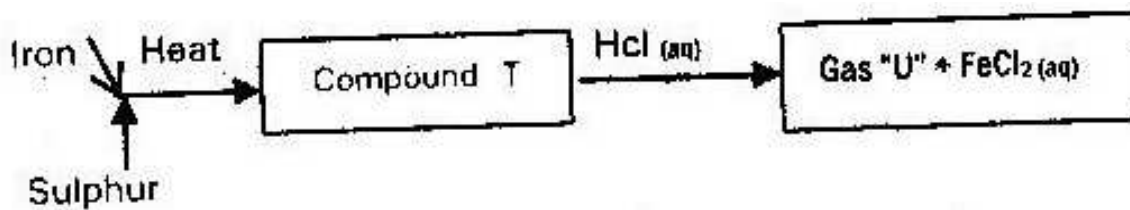

- (a) Name the substance that passes through tube I and II (2 mks)
- (b) What is the purpose of the hot compressed air in this process (10 mks)

3.

State what would be observed when dilute hydrochloric acid is added to product formed when a mixture of iron fillings and sulphur are heated (1 mk)

4.

Study the flow chart below and answer the questions that follow

- (a) Name compound "T" and gas "U" (2 mks)
- (b) Give a chemical test that you could use to identify gas "U" (1 mk)

5.

Sulphur (IV) oxide and nitrogen (IV) oxide react as shown in the equation below

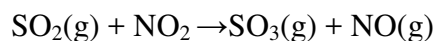

- (i) Using oxidation numbers of either sulphur or nitrogen show that this is a redox reaction (2 mks)
- (ii) Identify the reducing agent (1 mk)

6.

In an attempt to prepare – sulphur (IV) oxide gas, dilute sulphuric acid was reacted with Barium sulphite. The yield of sulphur (IV) oxide was found to be negligible. Explain (2 mks)

7.

When a solid sample of sulphur is heated in a test tube. It changes into a liquid, which flow easily. On further heating the liquid darkens and does not flow easily. Explain these observations (3 mks)

8.

A certain matchstick head contains potassium Chlorate and sulphur. On striking two substances react to produce sulphur (IV) oxide and potassium chloride.

Explain the environmental effect of using such matches in large numbers

(2 mks)

9.

Describe a simple laboratory experiment that can be used to distinguish between sulphide and sodium carbonate.

(2 mks)

10.

What observation would be made if hydrogen sulphide gas was bubbled through a solution of Zinc- nitrate?

(1 mk)

11.

The apparatus shown below was set up to prepare and collect hydrogen sulphide gas

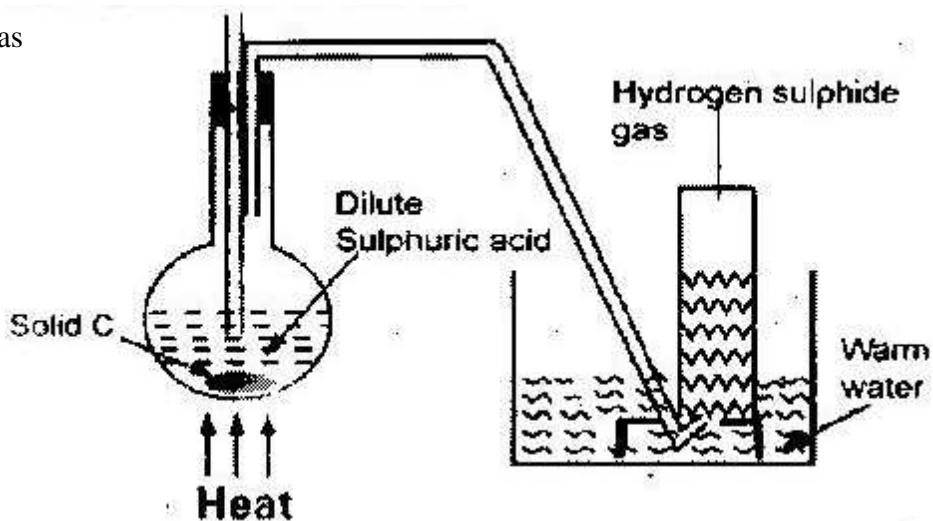

- (a) Name solid C (1 mk)
- (b) Give a reason why warm water is used (1 mk)
- (c) What observations would be made if hydrogen sulphide gas was bubbled into a solution of lead (II) Nitrate (1 mk)

12.

Concentrated Nitric acid was added to iron (II) sulphate acidified with dilute sulphuric acid and the mixture was heated. The solution turned from pale green to yellow with evolution of brown gas. Explain this observation. (3 mks)

13.

In an experiment 30cm³ of 1.0M sulphuric acid were reacted with 30cm³ of 0.1M sodium hydroxide.

- (a) Write an equation for the reaction that took place (1 mk)
- (b) State the observation made when both blue and red litmus papers were dropped with the mixture (1 mk)
- (c) Give a reason for your answer in (b) above (1 mk)

14.

Sulphur exist in two crystalline forms

- (a) Name one crystalline form of sulphur (1 mk)
- (b) State two uses of sulphur (1 mk)

15.

Oleum ($\text{H}_2\text{S}_2\text{O}_7$) is an intermediate product in the industrial manufacture of sulphuric acid

- (a) How is Oleum converted to sulphuric acid? (1 mk)
(b) Give one use of sulphuric acid (1 mk)

16.

Dilute hydrochloric acid and sodium sulphite were reacted as shown in the set up below

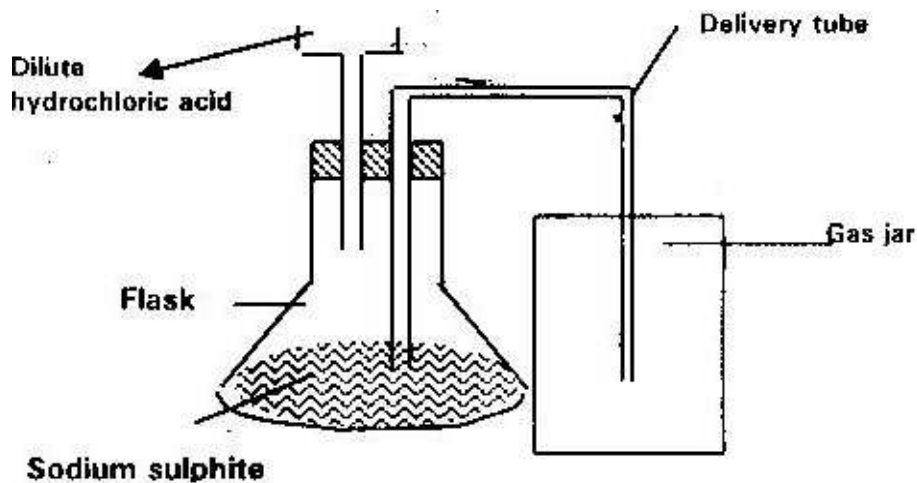

- (a) Name the gas produced in the flask (1 mk)
(b) Give two reasons why no gas was collected in the gas jar (2 mks)

17.

Determine the oxidation state of sulphur in the following compounds

- (a) H_2S (1 mk)
(b) $\text{Na}_2\text{S}_2\text{O}_2$ (1 mk)

18.

When hydrogen sulphide gas was bubbled into aqueous solution of iron (III) chloride a yellow precipitate was formed

- (a) State another observation that was made (1 mk)
- (b) Write an equation for the reaction that took place (1 mk)
- (c) What type of reaction was undergone by hydrogen sulphide gas?

19.

Study the flow chart below and answer the question that follows

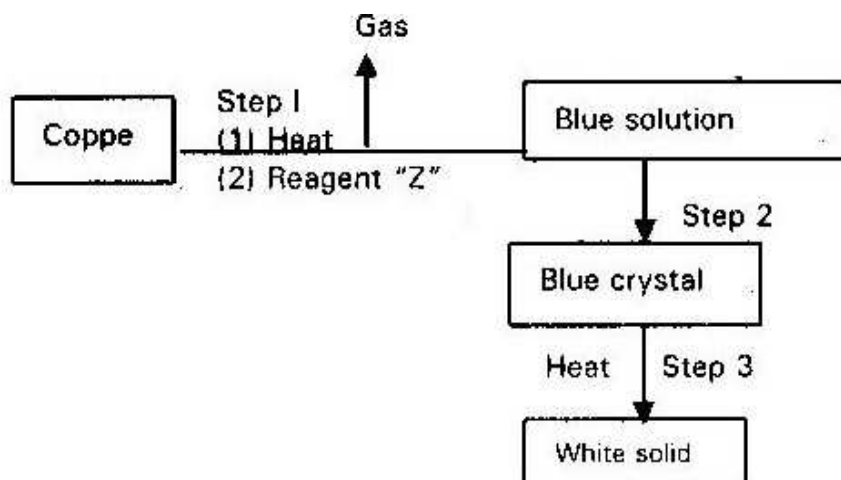

- (a) Name reagent "Z" (1 mk)
- (b) Describe the process which takes place in step 2 (1 mk)
- (c) Identify the white solid (1 mk)

20.

Below is a sketch of a graph showing the change in viscosity ((Ease to flow) with temperature when solid sulphur is heated.

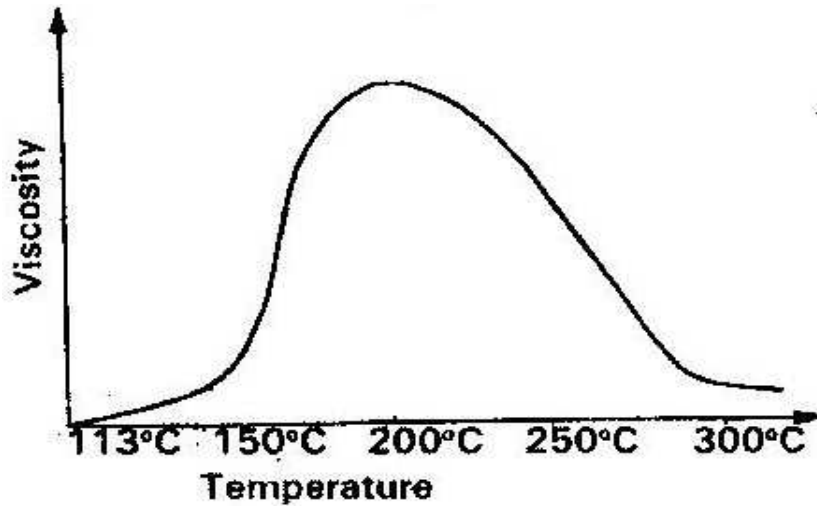

Describe what happens to the sulphur molecules when sulphur is heated from 1500C to about 2000C. (2 mks)

21.

- (a) State the observation made at the end of the experiment when a mixture of iron powder and sulphur is heated in a test tube. (1 mk)
- (b) Write an equation for the reaction between the product in (a) above and dilute hydrochloric acid. (1 mk)
- (c) When a mixture of iron powder and sulphur is heated, it glows more brightly than that of iron fillings and sulphur. Explain this observation (1 mk)

22.

- (a) The graph below shows the solubility of sulphur (IV) Oxide gas at different temperatures. Use the information in it to answer the questions that follows

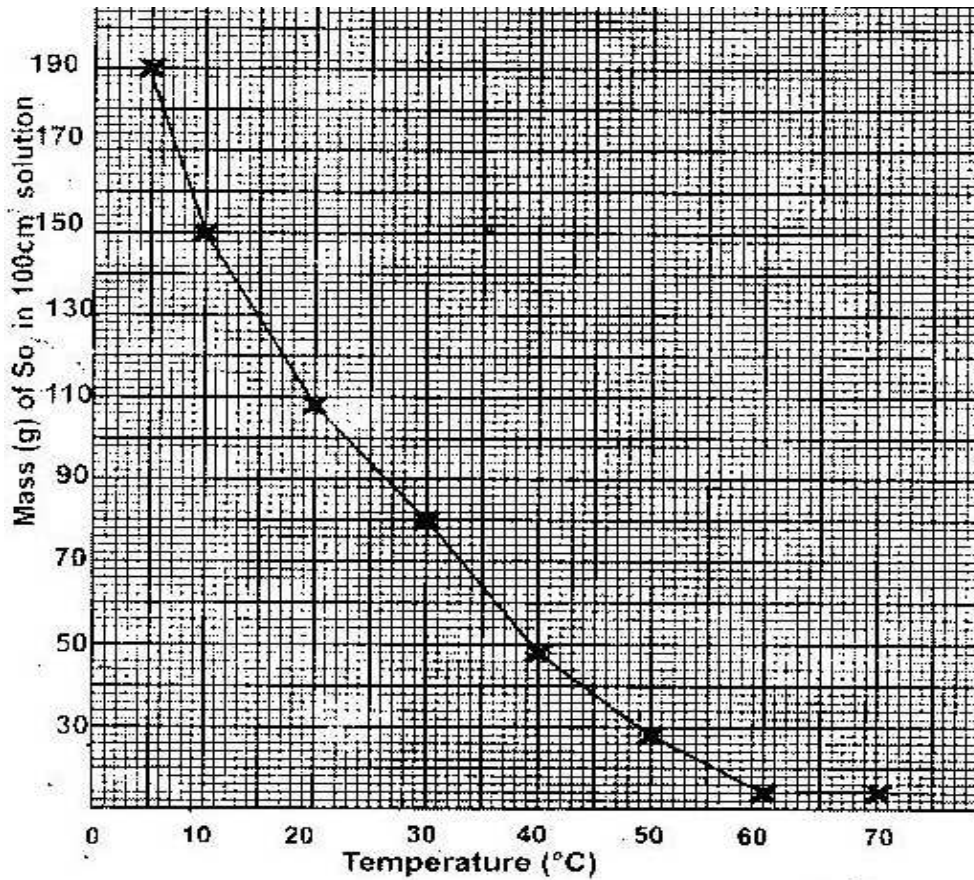

- (i) From the graph determine
- I. The lowest temperature at which 1,000 cm³ of solution would contain 116g of sulphur (IV) oxide (1 mk)
 - II. The maximum mass of sulphur (IV) oxide that would dissolve in 15 litres of solution at 100C

(ii) Sodium hydroxide reacts with sulphur (IV) oxide according to the following equation

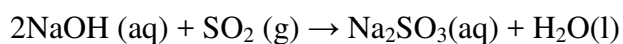

Using the information in the graph, determine the volume of 2m sodium Hydroxide required to completely neutralize one litre of saturated sulphur (IV) oxide at 230C (S= 32.0) (O= 16.0)

(3 mks)

(b) Study the flow chart below and answer the questions that follow

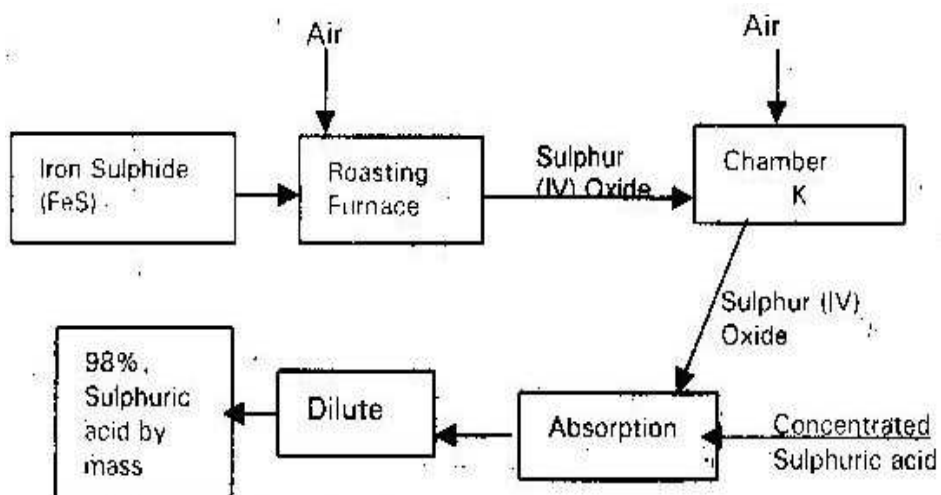

- (i) Write equations for the reaction taking place at
- I. The roasting furnace (1 mk)
 - II. The absorption tower (1 mk)
 - III. The diluter (1 mk)
- (ii) The reaction that takes place in chamber “K” is
- $$\text{SO}_2 (\text{g}) + \frac{1}{2} \text{O}_2 (\text{g}) \rightleftharpoons \text{SO}_3 (\text{g})$$
- I. Explain why it is necessary to use excess air in chamber “K’ (1 mk)
 - II. Name another substance used in chamber “k” (1 mk)

23.

The reaction between sulphur (IV) oxide and oxygen to form sulphur (VI) oxide in the contact process is exothermic

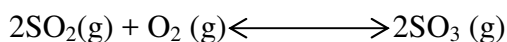

A factory manufacturing sulphuric acid by contract process produces 350 kg of sulphur (VI) Oxide per day. (Condition for the reaction: a catalysts 2 atmospheres pressure and temperature between 400 – 5000C

- (i) What is meant by an exothermic reaction?
- (ii) How would the yield per day of sulphur (VI) oxide be affected if temperatures lower than 4000 C is used explain (3 mks)
- (iii) All the sulphur (VI) oxide produced was absorbed in concentrated sulphuric acid to form oleum

$$\text{H}_2\text{SO}_4 (\text{l}) + \text{SO}_3 (\text{g}) \rightarrow \text{H}_2\text{S}_2\text{O}_7 (\text{l})$$

Calculate the mass of oleum that was produced per day (3 mks)

(S= 32.0) (O= 16.0) (H= 1.0)

24.

- (a) Name one ore from liquid which copper metal is extracted (1mk)
- (b) The flow chart below shows a sequence of reaction starting with copper.

Study it and answer the questions that follows

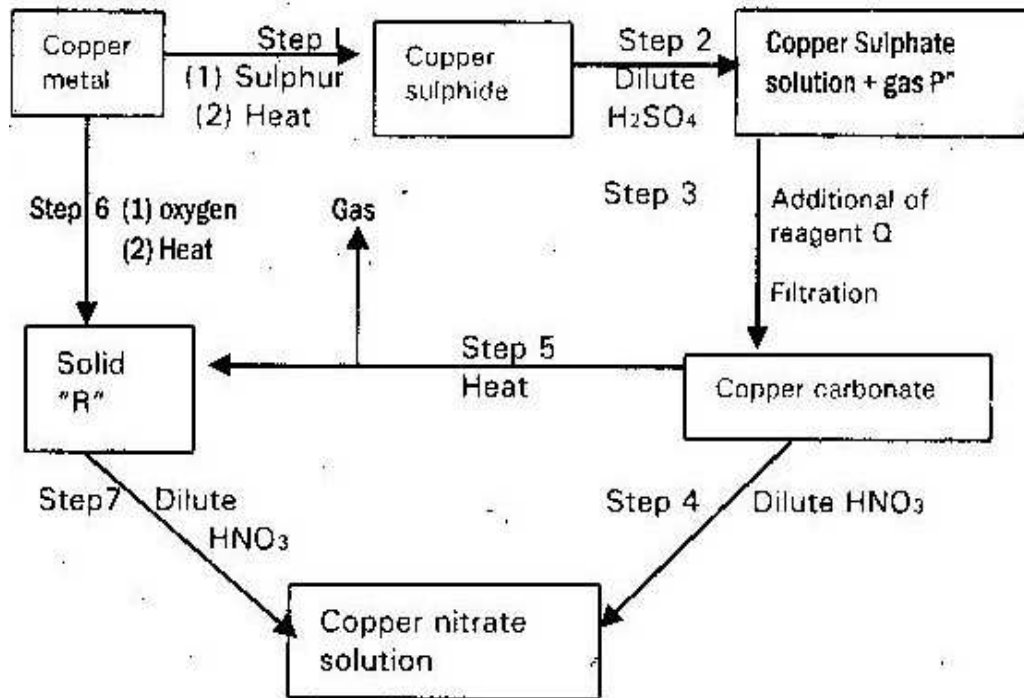

- (i) Identify gas "p" and reagent Q and "R" (2 mks)
- (ii) Write an equation for the reaction that place in step 5 (1 mk)
- (iii) State the observation made in steps 4 and 7 (1 nk)
- (c) Bronze is an alloy of copper and another metal
- (i) Name the other metal (1 mk)
- (ii) Give one use of bronze (1 mk)

25.

The diagram below illustrates how sulphur is extracted by frasc process

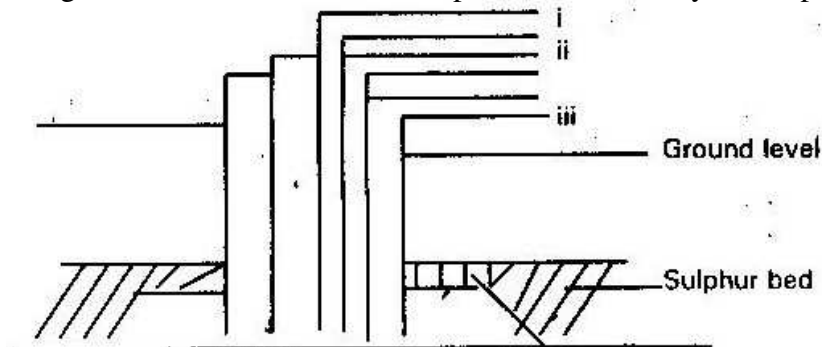

(a) Label the pipe through which superheated water is pumped in (1 mk)

(b) The equation below shows the oxidation of sulphur (IV) oxide to sulphur (VI) oxide in the contact process

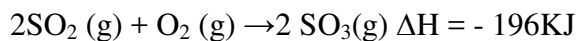

(i) Name the catalyst used in this process (1 mk)

(ii) State and explain the effect on the yield of sulphur (VI) oxide when

I. The temperature is increased (2 mks)

II. The amount of oxygen is increased (2 mks)

(iii) Describe how sulphur (VI) oxide is converted to sulphuric acid in the contact process. (2 mks)

(c) Ammonium sulphate is a fertilizer produced by passing ammonia gas into concentrated sulphuric acid

(i) Write the equation for the reaction (1 mk)

- (ii) Calculate the mass in kg of sulphuric acid required to produce 25kg of fertilizer (S= 32.0) (O= 16.0) (N = 14.0) (H. 1.0) (3 mks)

26.

- (a) The diagram below shows some processes that takes place during the industrial manufacture of sulphuric acid.

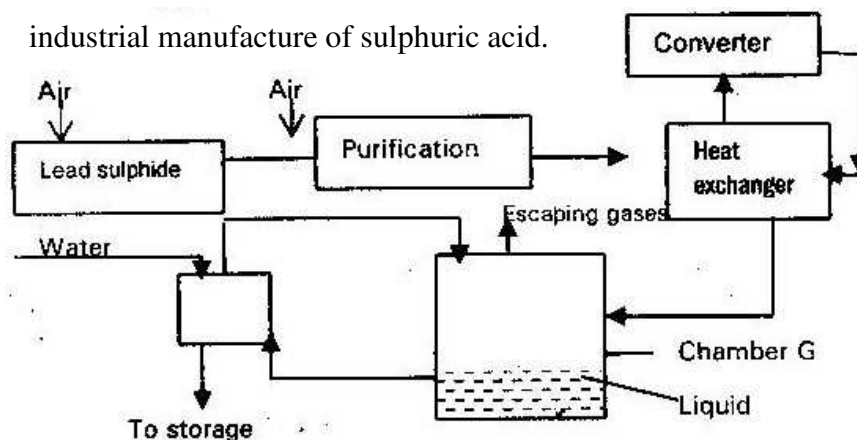

- (i) Write the equation for the reaction in which sulphur (IV) Oxide is produced
- (ii) Why is it necessary to keep the gas pure and dry? (1 mk)
- (iii) Describe the process that takes place in chamber G (1 mk)
- (iv) Name the gases that escape into the environment (1 mk)

- (v) State and explain the harmful effect on the environment of one of the gases
- (vi) Give one reason why it is necessary to use 2- 3 atmospheric pressures and not more (1 mk)
- (b) (i) Complete the table below to show the observations made when concentrated sulphuric acid add to the substances shown

Substances	Observations
Iron fillings	
Crystals of white sugar	

- (ii) Give a reason for the observation made using
- I. Iron fillings (1 mk)
- II. Crystal of white sugar (1 mk)
- (c) Name one fertilizer made from sulphuric acid (1 mk)
- (d) Suggest a reason why BaSO_4 (a pigment made from sulphuric acid) would be suitable in making paint for cars (1 mk)

27. When sulphur is heated in a test tube, the yellow crystal melt to form a golden yellow liquid, which changes at 180°C . Into dark brown, very viscous liquid more heating to 400°C a brown less viscous liquid.

- (i) What is the molecular mass sulphur in the yellow crystals (1 mk)
- (ii) If the brown liquid at 400°C is cooled rapidly at room temperature, which form of sulphur is produced? (1 mk)
- (iii) Explain why the molten sulphur becomes viscous (2 mks)

28. (a) State two observations made when acidified potassium permanganate is reacted with hydrogen sulphide (2 mks)

(b) Explain the observation made in (a) above (1 mk)

(c) Write an ionic equation for the above reaction (1 mk)

29. Below is a flow chart showing some of the major steps involved in the manufacture of sulphuric (VI) acid by contact process

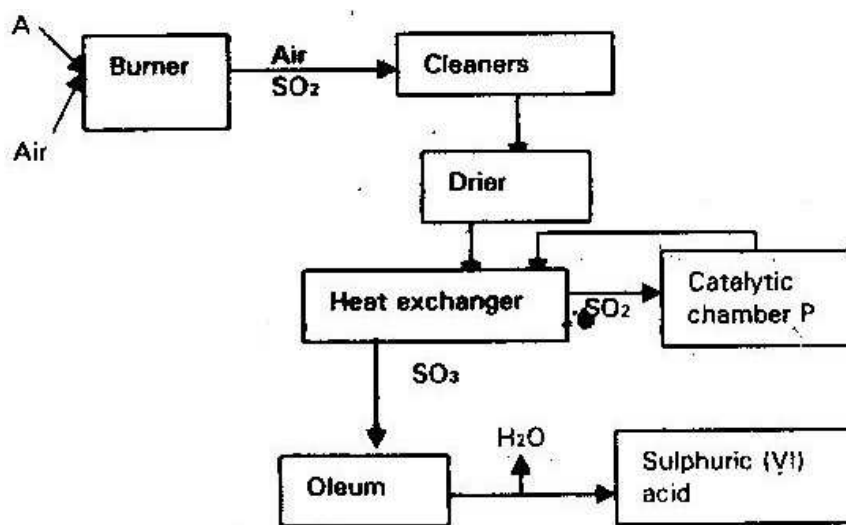

(a) Identify

(i) Substance A (1 mk)

(ii) Catalyst used in chamber "P" (1 mk)

(b) The conversion of S_2 to SO_3 in the contact process is shown by the equation



What would be the effect of?

(i) Increasing the concentration of oxygen (1 mk)

(ii) Increasing the temperature (1 mk)

(c) Write an equation for

(i) The formation of Oleum (1 mk)

(ii) Formation of sulphuric (VI) acid from Oleum (1mk)

30. State and explain the observation made when hydrogen – sulphide gas is bubbled in a solution of iron (III) ions (1 mk)

31. State all the changes that will be seen when concentrated sulphuric acid is added to cane sugar in a boiling tube. (2 mks)

32. The set up below shows preparation of sulphur (VI) oxide study it and answer the questions that follows.

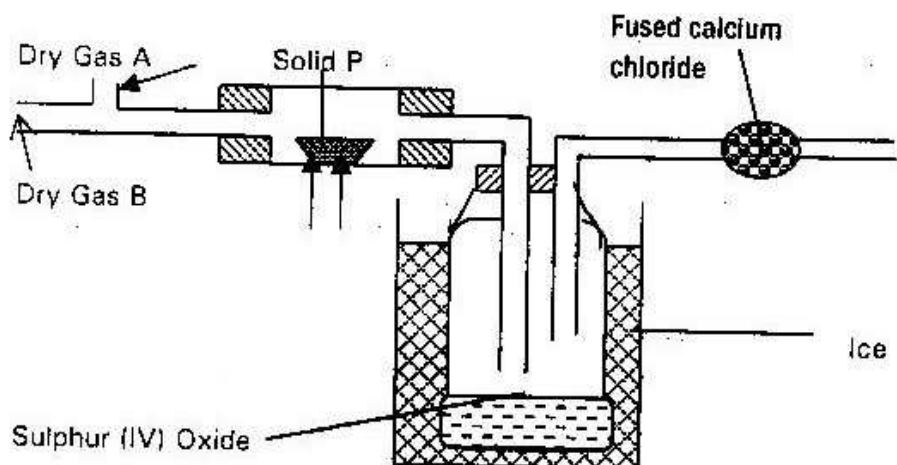

(b) Write an equation for the reaction taking place in the combustion tube. (1 mk)

33. When sulphur (IV) oxide is passed into aqueous solution of chlorine the greenish yellow colour of chlorine disappears. Write equation for the reaction taking place

(1 mk)

34. Study the flow chart below and answer the question that follows

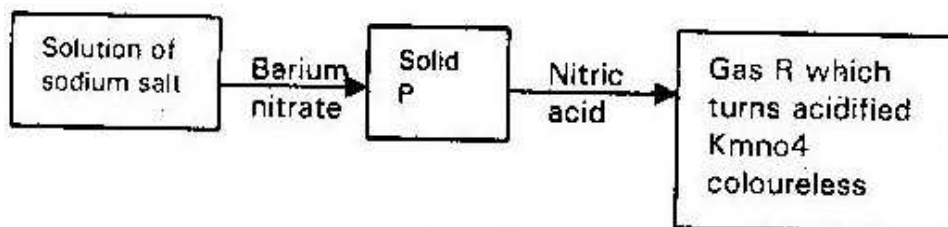

(a) Name solid P (1 mk)

(b) Give the formula of sodium salt (1 mk)

(c) Name gas R (1 mk)

- (d) Write an equation for the reaction between Nitric acid and solid "P" (1 mk)
35. Sulphur is one of the elements that exhibits allotropy
- (i) What is allotropy (1 mk)
 - (ii) Give another element other than sulphur that shows allotropy (1 mk)
 - (iii) Name two allotropes of sulphur (2 mks)
 - (iv) State two major uses of sulphur (2 mks)
36. 9.0g of zinc sulphide reacted with 100cm^3 of 0.2m sulphuric acid. Determine the reagent that was in excess. (Zn = 65, S= 32) (2 mks)

TOPIC 6

CHLORINE AND ITS COMPOUNDS

1.

When excess chlorine gas is bubbled through dilute sodium hydroxide solution the resulting solution act as a bleaching agent.

- (a) Write an equation for the reaction between chlorine gas and sodium hydroxide solution (1 mk)
- (b) Explain how the resulting solution acts as a bleaching agent(2mks)

2.

A solution of chlorine in Tetrachloromethane turns colourless when propene gas is bubbled through it

- (a) What type of reaction takes place (1 mk)
- (b) Write an equation for the above reaction (1 mk)

3.

The reaction of propane with chlorine gas gave a compound with formula C_3H_7Cl

- (a) What condition is necessary for the above reaction to take place (1 mk)
- (b) Draw a structured formula of compound C_3H_7Cl

4.

In an experiment chlorine gas was passed into moist hydrogen sulphide in a boiling as shown in the diagram

(a) What observations was made in the boiling tube (1 mk)

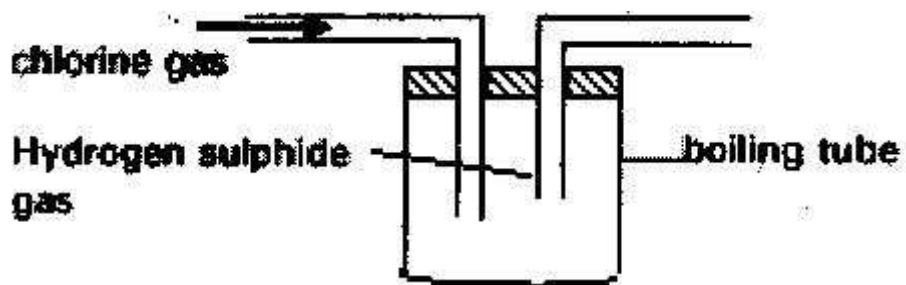

(b) Write an equation for the reaction which took place in the boiling tube

(c) What precautions should be taken in carrying out this experiment? Give a reason. (1 mk)

5.

The diagram below shows a set up for the laboratory preparation and collection of dry chlorine gas

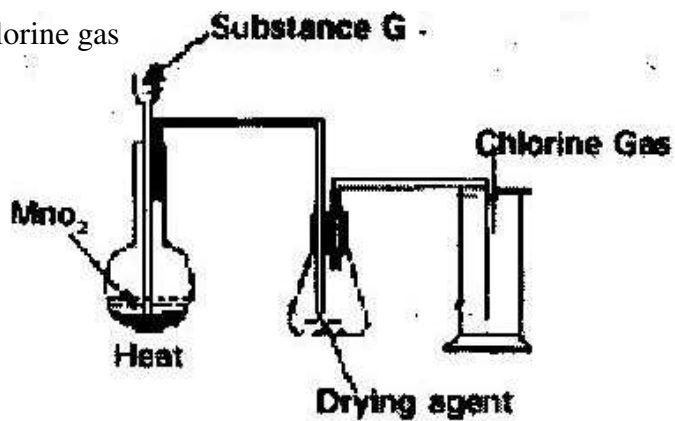

(a) Name

(i) Substance G (1 mk)

(ii) Suitable drying agent (1 mk)

(b) What property of chlorine make it possible for it to be collected as shown in the diagram (1 mk)

6.

The following two sets were carried out on chlorine water contained in two test tubes

- (a) A piece of blue flower was dropped into the first test tube. Explain why the flower was bleached. (2 mks)
- (b) The second test tube was corked and exposed to sunlight. After a few days it was found to contain gas that rekindled a glowing splint. Write an equation for the reaction which produced the gas. (1 mk)

7.

The set up below was used to prepare hydrogen chloride gas and react it with iron powder. Study it and answer the questions that follows

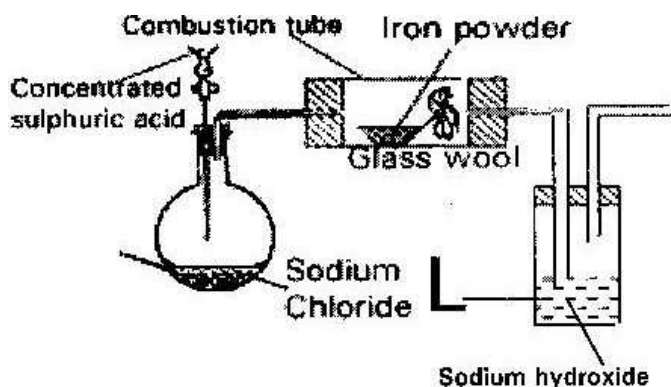

At the end of the reaction, the iron powder turned to light green solid

- (a) Identify the light green solid (1 mk)
- (b) At the beginning of the experiment the pH of the solution in container “L” was about 14. At the end the pH was found to be 2. Explain.

8.

Calcium Oxide can be used to dry ammonia gas

- (a) Explain why calcium oxide cannot be used to dry hydrogen chloride gas
- (b) Name one drying agent for hydrogen chloride gas (1 mk)

9.

The reaction between hot concentrated Sodium hydroxide and chlorine gas produces sodium chlorate (V), sodium chloride and water

- (a) Write the equation for the reaction (1 mk)
- (b) Give one use of sodium chlorate (V) (1 mk)

10.

Water from a town in Kenya is suspected to contain chloride ions but not sulphate ions. Describe how the presence of chloride ions in the water can be shown

(2 mks)

11.

The diagram below represents the set up that was used to prepare and collect dry hydrogen chloride gas in the laboratory.

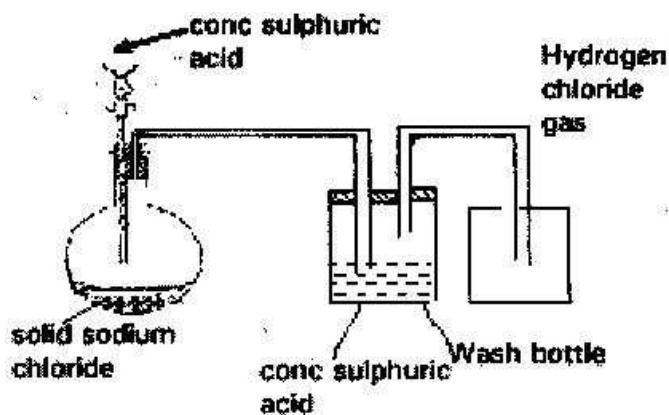

- (i) State the purpose of concentrated sulphuric acid in the wash bottle (1 mk)
- (ii) Write an equation for the reaction between dry hydrogen chloride gas and heated iron (1 mk)
- (iii) Hydrogen chloride gas is dissolved in water to make hydrochloric acid. State one use of hydrochloric acid (1 mk)

12.

Complete the following table by filling in the missing test and observations

No.	Gas	Test	Observation
I	Chlorine	Put a moist red litmus paper into the gas	
II	Sulphur (IV) Oxide		Paper turns green
III	Butene	Add drop of bromine water	

13.

In an experiment, a test tube full of chlorine water was inverted in chlorine water as shown in the diagram below and the set up left in sunlight for one day.

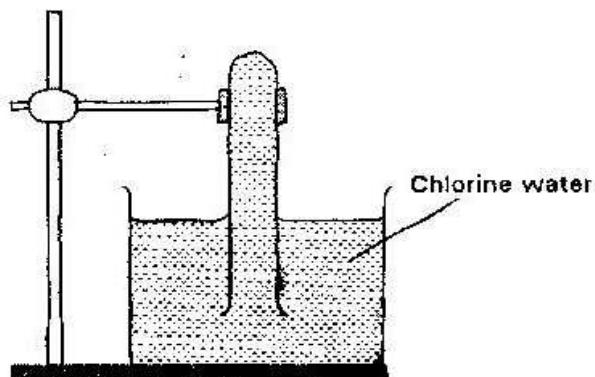

After one day, a gas was found to have collected in the test-tube

- (a) Identify the gas
- (b) What will happen to the pH of the solution in the beaker after one day?
Give an explanation. (2 mks)

14.

The diagram below is part of a set up used in the laboratory preparation of a gas

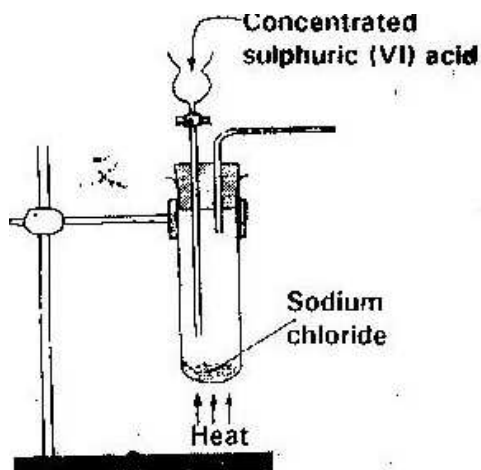

Complete the diagram to show how a dry sample of the gas can be collected

(3 mks)

15.

The diagram below shows an incomplete set up of the laboratory preparation and collection chlorine gas. Study it and answer the questions that follows

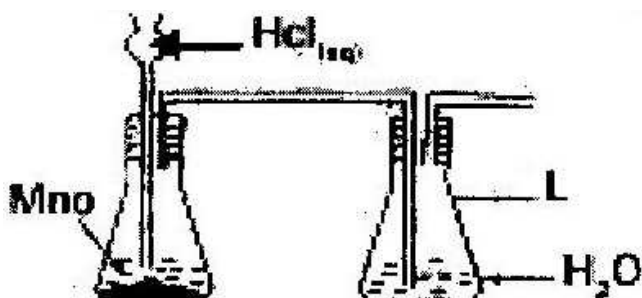

(i) Complete the set up to show how dry chlorine gas may be collected

(3 mks)

(ii) What is the function of the water in flask L

(iii) The equation for the redox reaction that takes place is



Explain using oxidation numbers which species is reduced (2 mks)

16.

The set up below was used to prepare anhydrous chloride of a number of elements in laboratory where no fume cupboard was available. The chloride were to be collected in flask 1

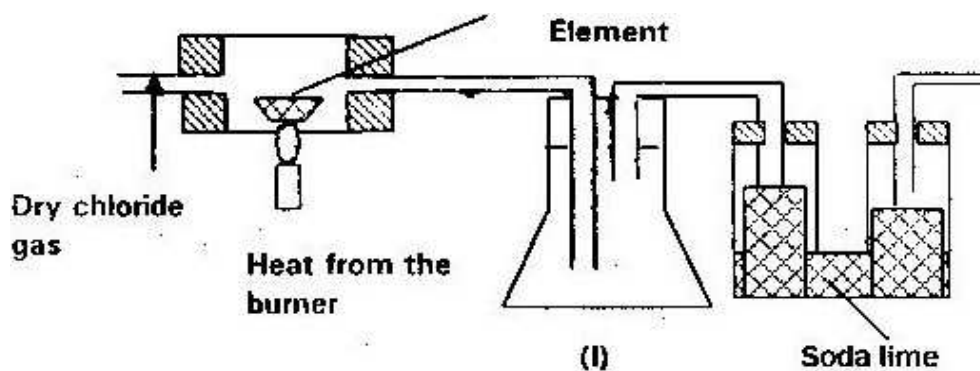

The following table shows the melting and boiling points of the chloride that were prepared

Chloride	NaCl	AlCl ₃	SiCl ₄	PCl ₃
Melting point in °C	801	Sublime (178)	-70	-91
Boiling point °C	1413		58	76

- (a) Explain why it is necessary to pass dry chlorine gas through the apparatus before heating each element (2 mks)
- (b) Give two reasons why tube II is filled with soda lime (a mixture of sodium hydroxide and calcium hydroxide) (2 mks)

- (c) Explain why it would not be possible to collect any sodium chloride in flask I (1 mk)
- (d) Name one other substance that can be used in tube II (1 mk)
- (e) Write an equation for the reaction that forms phosphorous (III) chloride
- (f) Describe how you would separate a mixture of sodium chloride and aluminium chloride (2 mks)

17.

- (a)
- (i) In the spacer provided sketch a diagram to show how hydrogen chloride gas can be prepared and collected in the laboratory using sodium chloride and concentrated sulphuric acid (the gas need not be dry) (4 mks)
- (ii) Write an equation for the reaction that takes place
- (iii) Name one drying for hydrogen chloride gas
- (iv) State and explain the observation that would be made when hydrogen chloride gas is bubbled through a solution of lead (II) nitrate (3 mks)
- (v) Concentrated hydrochloric acid is used for removing oxide from metals surfaces (pickling). Explain why concentrated nitric acid cannot be used for the same purpose
- (b) A sample of hydrogen chloride gas dissolved in water to make 250 cm^3 of solution. 25 cm^3 of the solution required 46 cm^3 of 11.0 M sodium hydroxide for complete neutralization.
- (i) Calculate the number of moles of hydrochloric acid in 25 cm^3 solution (3 mks)

- (ii) Determine the mass of hydrogen chloride that was dissolved to make 250 cm^3 of solution. (Cl = 35.5) (H= 1.0) (2 mks)

18.

- (a) Give the name of one reagent which when reacted with concentrated hydrochloric acid produces chlorine gas (1 mk)
- (b) A student set out to prepare iron (III) chloride using apparatus shown in the diagram below

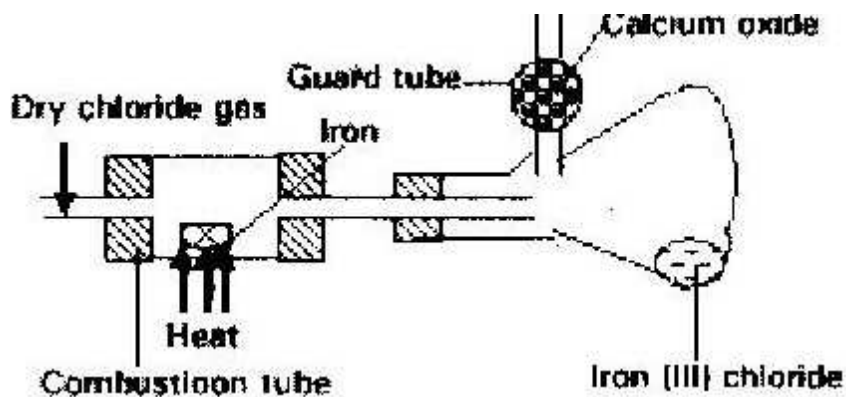

- (i) Explain why it is necessary to pass chlorine gas through the apparatus before heating begins? (1 mk)
- (ii) Calcium oxide would be preferred to calcium chloride in the guard tube (1 mk)
- (iii) What property of iron (III) chloride makes it possible to be collected as shown in the diagram (1 mk)
- (iv) The total mass of iron (III) chloride formed was found to be 0.5g. Calculate the volume of chlorine gas that reacted with iron. (Fe = 560 (Cl = 35.5) and molar gas volume of 298k is 24,000 cm^3 (3 mks)

- (c) When hydrogen sulphide gas passed through a solution of iron (III) chloride the following observation was made
- The colour of the solution changed from reddish brown to green and yellow solid was deposited. Explain these observations (2 mks)
- (d) State and explain the observations that would be made if a moist blue-litmus paper was placed in a gas jar full of chlorine gas (2 mks)

. Study the flow chart below and answer the questions that follows

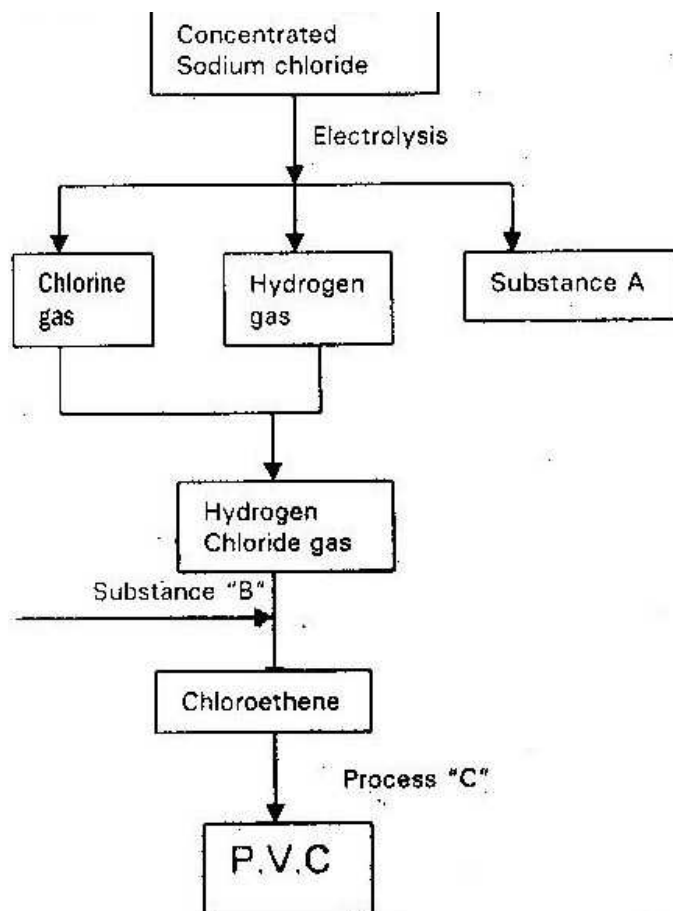

- (a) Identify substance A and B (2 mks)
- (b) Name process "C" (1 mk)
- (c) Give one use of P.V.C (1 mk)
- (d) Write an ionic equation for the reaction in which chlorine gas is produced
(1 mk)
- (e) State and explain the observation that would be made if chlorine gas was bubbled into an aqueous solution of sodium iodide (1 mk)
- (f) In the preparation of a bleaching agent (Sodium hypochlorite) excess chlorine gas was bubbled into 15 litres of cold 2M sodium hydroxide
- (i) Write an equation for the reaction between chlorine gas and dilute sodium hydroxide (1 mk)
- (ii) (a) Calculate the number of moles of sodium hydroxide used (1 mk)
- (b) Calculate the mass in kg of sodium hypochlorite produced
(Ma = 23) (cl = 35.5) (O=16) (3 mks)

19. (a)

The table below shows some properties of chlorine, bromine and iodine

Elements	Formula	Colour and state at room temperature	Solubility in water
Chlorine	Cl ₂	i.....	Soluble
Bromine	Br ₂	Brown liquid	ii.....
Iodine	I ₂	iii.....	Slightly soluble

Complete the table by giving the missing information in (i) (ii) and (iii)

(3 mks)

(b) Chlorine gas is prepared by reacting concentrated hydrochloric acid with manganese (IV) oxide

(i) Write the equation for the reaction between concentrated hydrochloric acid and manganese (IV) oxide (1 mk)

(ii) What is the role of manganese (IV) oxide in this reaction (1 mk)

(c) (i) Iron (III) chloride react with chlorine gas to form substance "E" identify substance "E" (1 mk)

(ii) During the reaction in C (i) above 6.30g of iron (II) chloride were converted to 8.06g of substance "E" Calculate the volume of chlorine gas used. (CL= 35.5) Molar gas volume a room temperature = 24000 cm³ (Fe = 56) (3 mks)

(d) Draw and name the structure of the compound formed when excess chlorine gas is reacted with ethane gas (3 mks)

(e) Give one industrial use of chlorine (1 mk)

20.

The diagram below shows the set up used in an experiment to prepare chlorine gas and react it with aluminium foil. Study it and answer the questions that follow

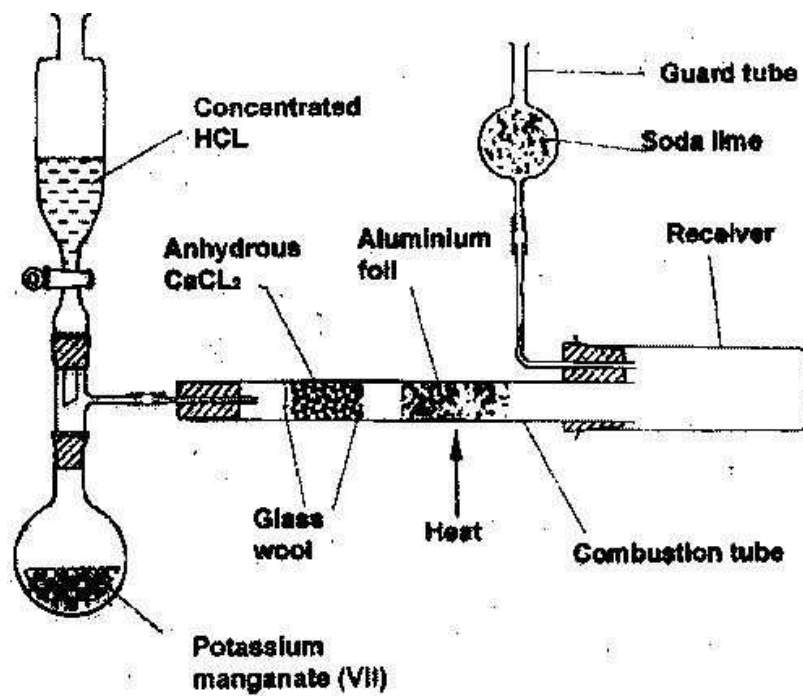

- (a) In the experiment, concentrated hydrochloric acid and potassium manganate (VII) were used to prepare chlorine gas. State two precautions that should be taken in carrying out this experiment. (2 mks)
- (b) Write the formula of another compound that could be used instead of potassium manganate (VII) (1 mk)
- (c) Explain why is necessary to allow the acid to drip slowly onto potassium manganate (VII) before the aluminium foil is heated. (2 mks)
- (d) State the property of the product formed in the combustion tube that makes it possible for it to be collected in the receiver. (1 mk)
- (e) When 1.08g of aluminium foil were heated in a stream of chlorine gas, the mass of the product formed was 3.47g. Calculate the:
- (i) Maximum mass of the product formed if chlorine was in excess
(AL = 27; Cl = 35.5) (3 mks)
- (ii) Percentage yield of the product formed (1 mk)
- (f) Phosphorous trichloride is a liquid at room temperature what modification should be made to the set up if it is to be used to prepare phosphorous trichloride (1 mk)
21. (i) What is the action of chlorine on cold dilute sodium hydroxide (1 mk)
- (ii) Write down the equation for the above reaction (1 mk)
22. If chlorine gas is passed over heated iron fillings and the products dissolved in water, a yellow solution is formed
- (i) Identify the yellow solution (1 mk)

- (ii) What would be observed if aqueous sodium hydroxide solution was added to the yellow solution (1 mk)
- (iii) Write an equation for the reaction between the yellow solution and sodium hydroxide (1 mk)

23. A solution of hydrogen chloride in methylbenzene (toluene) has no effect on limestone. A solution of hydrogen chloride in water reacts with limestone to produce a gas explain (1 mk)

24. The diagram below represents the industrial manufacturer of hydrochloric acid. Study it and answer the questions that follow.

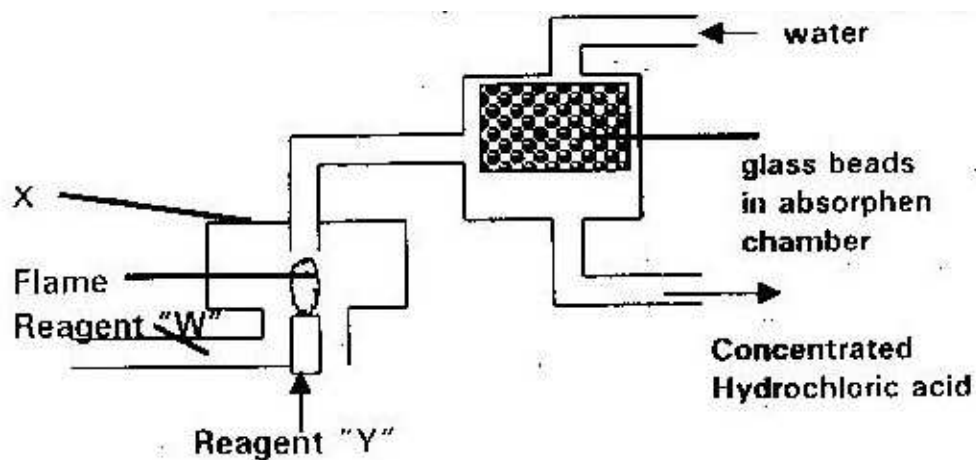

- (a) Name the reagents "W" and "Y" (1 mk)
- (b) Explain the role of the glass beads in the absorption chamber (1 mk)

- (c) Write an equation for the reaction in chamber "X" (1 mk)
- (d) Explain why hydrochloric acid formed appears yellow in colour (1 mk)

25. The diagram below shows preparation of hydrochloric acid

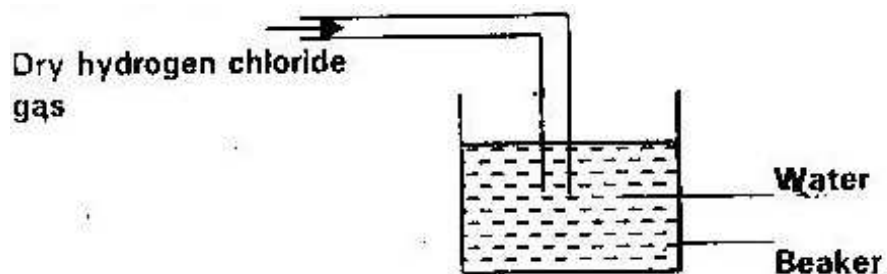

- (i) State one mistake in the diagram
- (ii) Hydrogen chloride does not have any effect on litmus paper unlike hydrochloric acid. Explain (1 mk)

26. The flowchart below summarizes the results of series of chemical reactions; study it and answer the questions that flows

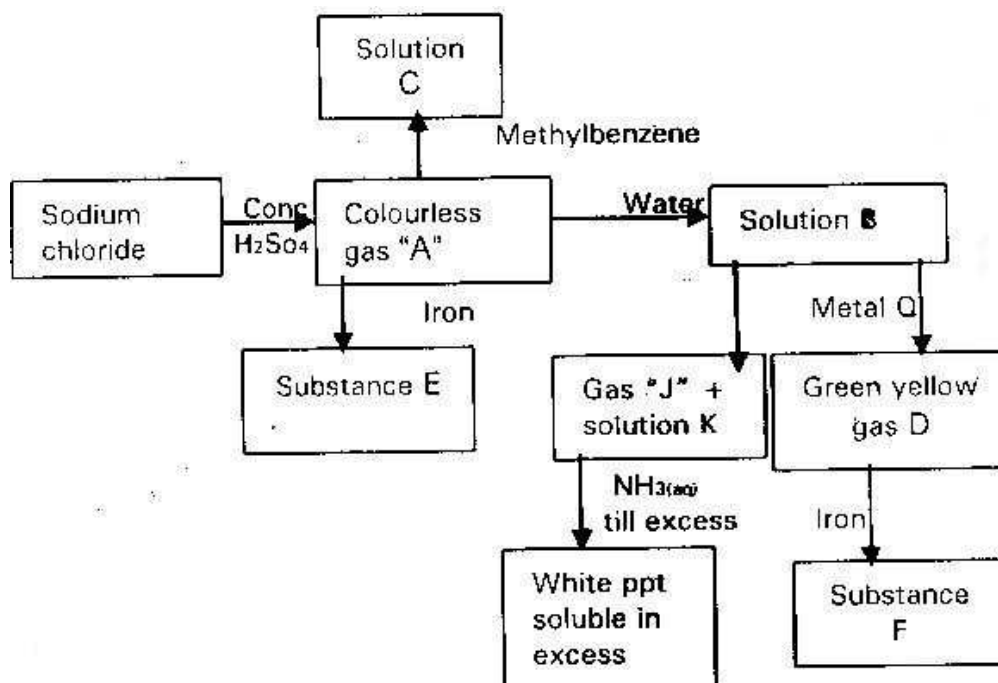

- (a) Identify gas “A” gas “D” substance E and F, Gas J solution K and metal Q
(4 mks)
- (b) What is the effect of solution “B” and a solution “C” on dry blue litmus paper? Explain
(2 mks)
- (c) What would you observe if excess ammonia solution is added to the solutions of substance “E” and “F” separately, explain your observations
(2 mks)
- (d) What reagent would you use to convert?
- (i) Substance “E” to substance “F” (1 mk)
- (ii) B to gas D (1 mk)
- (e) State the condition required in the formation of substance E or F which is not given in the diagram (1 mk)

27. Below is a set up of the apparatus used to prepare a dry sample of chlorine gas in the laboratory?

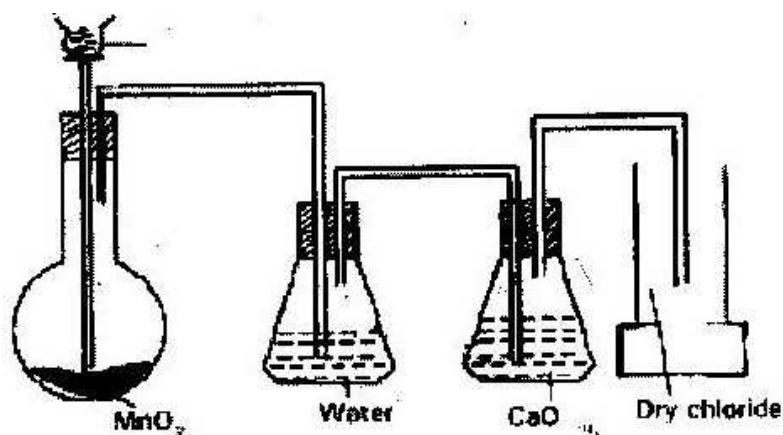

- (a) State two observations that were made in the reaction (2 mks)
- (b) Suggest two collections that should be made on the above set up so that the experiment is successful (2 mks)
- (c) What is the role of water in this set up? (1 mk)
- (d) (i) Write an equation for the reaction which produces chlorine (1 mk)
- (ii) What is the role of water of MnO_2 in this reaction (1 mk)
- (e) Determine the mass of chlorine gas formed if 40 cm^3 of 11.0 M hydrochloric acid was used in this reaction ($Cl = 35.5$) (3 mks)
- (f) 0.53 g of chlorine gas was reacted with iron to form 0.81 g of product. Determine the molecular formula of the products given that its relative molecular mass is 162.5 ($Fe = 56$) ($Cl = 35.5$) (4 mks)
- (g) Name two raw materials that are used with chlorine to produce hydrochloric acid on the large scale (1 mk)

28. The experiment below was set up to prepare iron (iii) chloride from chlorine

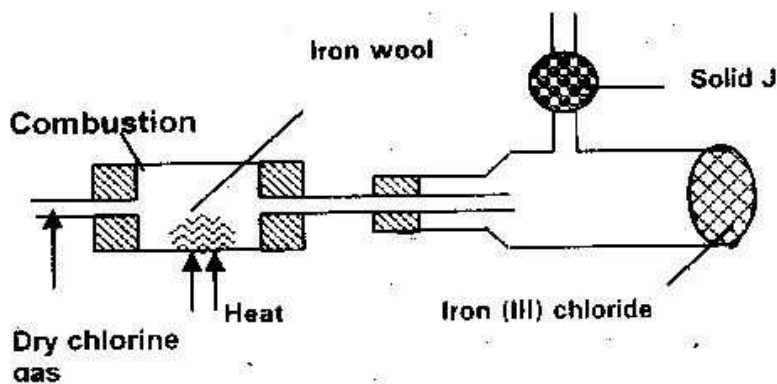

- (a) Name two reagents that could be used to prepare chlorine gas in the laboratory (1 mk)
- (b) Why is it necessary to dry chlorine gas before using it here?(1 mk)
- (c) What property of iron (III) chloride makes it possible to collect it as shown? (1 mk)
- (d) Give the names of solid J and state its functions (1 mk)
- (e) Where should this experiment be carried out and why (1 mk)
- (f) Give the equation for the reaction that takes place in the combustion tube
- (g) What would be observed if some chlorine water is shaken in gas jar of hydrogen sulphate gas (1 mk)

29. A student set up the apparatus below in the school laboratory to prepare and study the properties of a certain gas A.

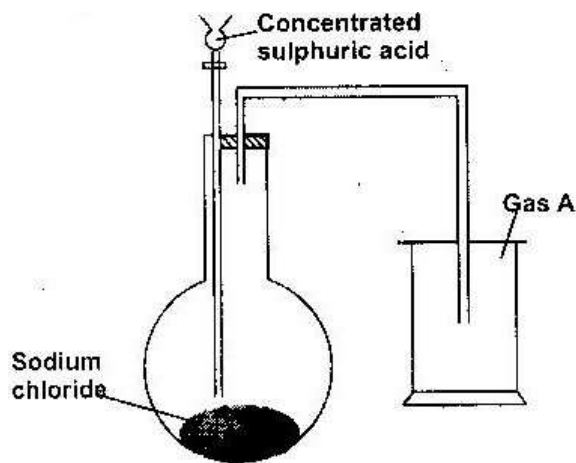

- (a) Name gas A (1 mk)
- (b) Write down a chemical equation for the reaction taking place to produce gas "A"
- (c) What major property of "gas" enables the student to collect the gas above as shown in the diagram (1 mk)
- (d) Suggest a possible drying agent if the student want to collect dry sample of the gas (1 mk)
- (e) Large quantities of the gas were bubbled into the same amount of water by passing the gas through an inverted filter funnel placed on the surface of the water to prepare a solution "Q"
- (i) Give a reason why a filter funnel is necessary in (e) above (1 mk)
- (ii) Some of the resulting solution Ce was mixed with silver nitrate-solution a white precipitate was observed. Name the white precipitate (1 mk)
- (iii) Write down an ionic equation for the formation of the white precipitate in e (ii) above
- (iv) Suggest the identity of solution Q. (1 mk)

FORM 4 WORK

TOPIC 1

ENERGY CHANGES

1.

Below is the energy level diagram for the reaction

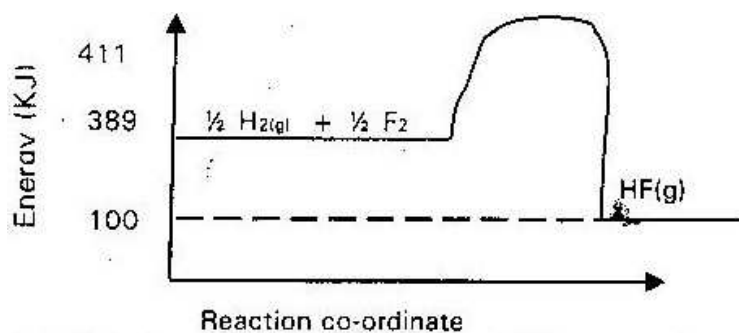
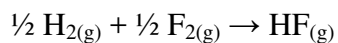

(a) Calculate the heat of formation of $\text{HF}(\text{g})$ (2 msk)

(b) Is this reaction exothermic or endothermic? (2 mks)

2.

When excess magnesium powder was added to 100cm^3 of 0.5m iron (III) sulphate solution, the pale green colour of solution faded and the temperature rose by 6.0°C

(a) Write an ionic equation for the reaction that takes place (1 mk)

- (b) Calculate the molar heat of reaction given that heat change = mass x temperature change x 4.2J/g/0C and the density of solution is 1g/cm³
(2 mks)

3.

Explain why the enthalpy of neutralization of ethanoic acid with sodium hydroxide is different from that of hydrochloric acid with sodium hydroxide
(2 mks)

4.

Use the information below to answer the questions that follows

Equation

Enthalpy = Formation

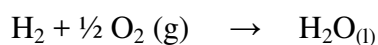

$$\Delta H = -286\text{kJ/mole}$$

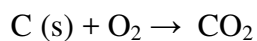

$$\Delta H = - 394\text{kJ/mol}$$

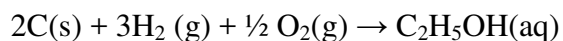

$$\Delta H_3 = 277 \text{ KJ KJ/Mole}$$

- (a) Define the term “enthalpy of formation of a compound”
(b) Calculate the molar enthalpy of combustion ΔH_4 of ethanol (2 mks)

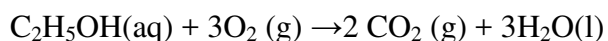

5.

When 0.6 g of element “J” were completely burnt in oxygen and all the heat evolved was used to heat 500 cm³ of water, the temperature of water rose from 23°C to 33°C. Calculate the relative atomic mass of element “J” given that the specific heat capacity of water = 4.2 J/g/°C density of water = 1.0 g/cm³ and molar heat of combustion of “J” is 380 kJ/mole (3 mks)

6.

Sulphur burns in air to form sulphur (IV) oxide. A simple energy level diagram for the reaction is given below. Study the diagram and answer the questions that follows

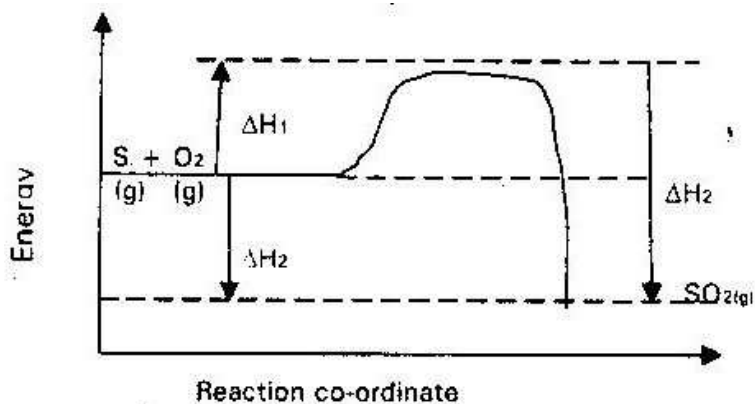

- (a) What do the following represent? ΔH_1 and ΔH_3 (2 mks)
- (b) Write an expression for ΔH_3 and in terms of ΔH_1 and ΔH_2 (1 mk)

7.

Study the information given in the table below and answer the questions below the table

Bond	Bond energy IJ/mole
C-H	414
CL- CL	244
C-CL	326
H- CL	431

Calculate the enthalpy change for the reaction

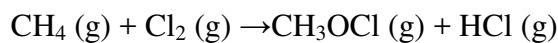

8.

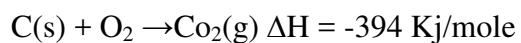
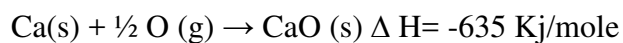

Calculate the enthalpy change for the reaction. (2 mks)

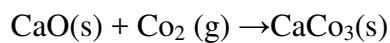

9.

Hydrogen and Flourine react according to the equation below



(a) Sketch an energy level diagram for the forward reaction (1 mk)

(b) Calculate the molar enthalpy of formation of HF (g) (1 mk)

10.

State and explain the function of tartaric acid in baking powder (1 mk)

11.

Use the equation below to answer the question that follows

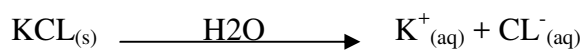

$$H_2 = + 14\text{KJ/mole}$$

(a) What name is given to H_1 ? (1 mk)

(b) Calculate the heat change of the process (2 mks)

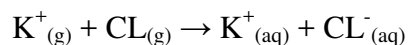

12.

Use the following equations to determine the heat evolved when aluminium metal is reacted with iron (III) oxide (3 mks)

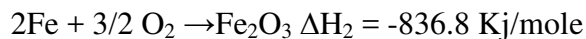
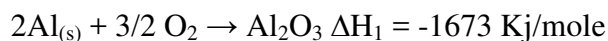

13. (a) What is meant by heat of vaporization (1 mk)

(b) The boiling point of ethanol, propanol and butanol are 78°C , 97.2°C and 117°C . Explain this trend (1 mk)

14.

Copper (II) sulphate reacts with barium chloride according to the equation below

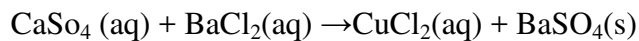

$$\Delta H = -17.7 \text{ KJ/mole}$$

Calculate the temperature change when 900 cm^3 of 1M copper (II) sulphate were added to 600 cm^3 of 1 m barium chloride

Assume heat capacity of solution is 4.2 J/g/K and density = 1 g/cm^3 (3 mks)

15.

Below is a sketch of a reaction profile

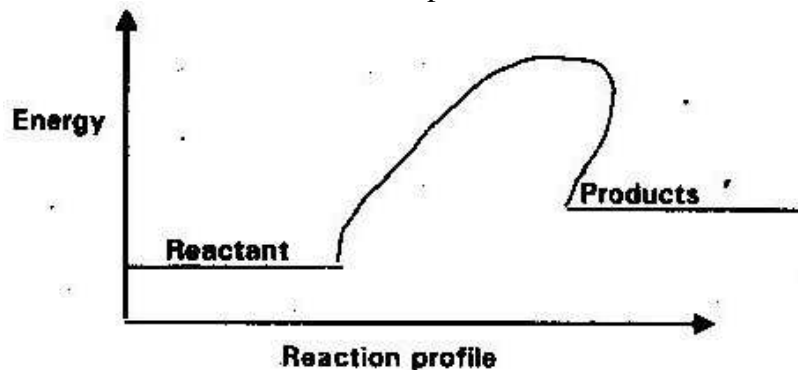

- (a) On the diagram shown the heat of reaction ΔH (1 mk)
- (b) State and explain the type of reaction represented by the profile (2mks)

16.

The table below shows some information about element I, II, III and IV which are in the same group of periodic table. Use the information to answer the questions that follows

Element	First ionization energy Kj/mole	Atomic radius (nm)
I	520	0.15
II	500	0.79
III	420	0.23
IV	400	0.25

State and explain the relationship between the variation in the first ionization energies and the atomic radii. (3 mks)

17.

The scheme below shows the energy changes that are involved between water and steam. Study it and answer the questions that follows

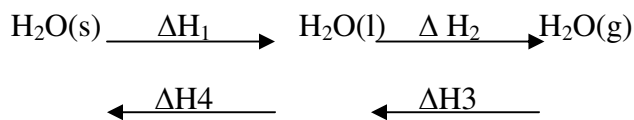

(a) What name is given to the energy change ΔH_4 (4 mks)

(b) What is the sign of ΔH_3 ? Give a reason (2 mks)

18.

At 200C, NO_2 and N_2O_4 Gases exist in equilibrium as shown in the equation below

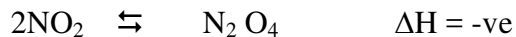

Brown pale yellow

State and explain the observations that would be made when:

(a) A syringe containing the mixture at 20°C is immersed in ice cold water

(b) Volume of gas in syringe reduced (1 ½)

19.

The graph below shows a curve obtained when water at 20°C was heated for 15 minutes

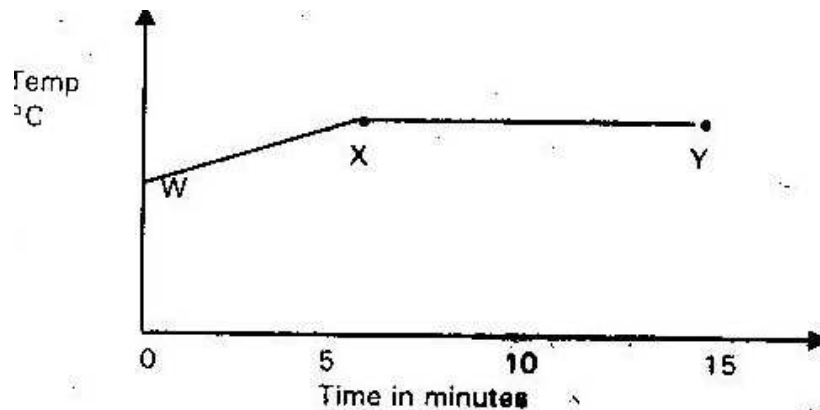

(a) What happens to the water molecules between points “W” and “X”

(b) In which part of the curve does a change of state occurs (1 mk)

(c) Explain why the temperature does not rise between points X and Y

(1 mk)

20.

Study the diagram below and answer the questions that follows

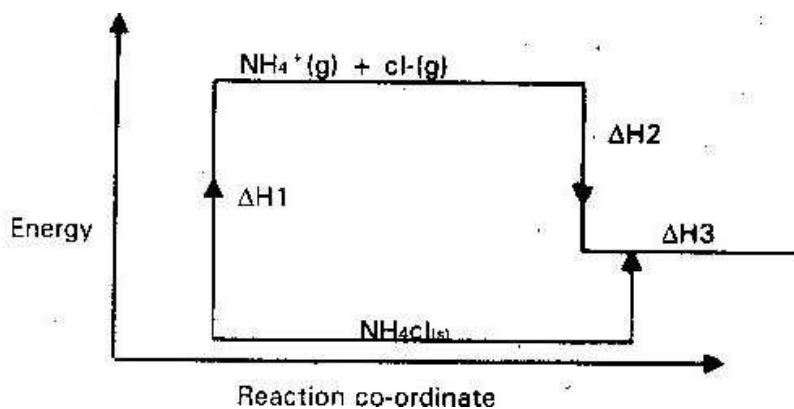

- (a) What do ΔH_1 and ΔH_2 represents? (2 mks)
- (b) Write an expression to show the relationship between ΔH_1 , ΔH_2 and ΔH_3

21.

The thermo chemical equations for the formulation of hydrogen peroxide under standard conditions are:

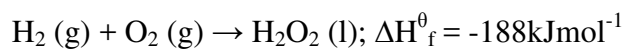
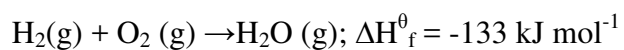

Write the thermo chemical equations for the molar heat of vaporization of hydrogen peroxide (2 mks)

22.

The diagram below is a sketch of the graph of the non-catalyzed decomposition of hydrogen peroxide.

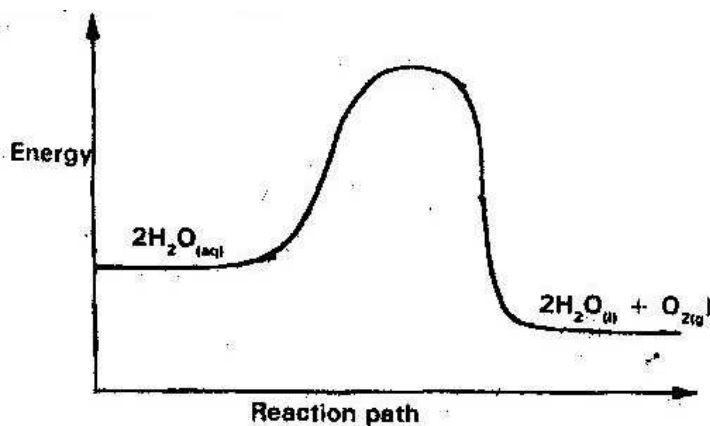

On the same axis, sketch the graph for the decomposition of hydrogen peroxide when manganese (IV) oxide is added (2 mks)

23.

The table below gives the solubilities of substances J, K and L at different temperatures

Substance	Solubility in grammes per 100g water at			
	0°C	20°C	40°C	60°C
J	0.334	0.16	0.097	0.0058
K	27.60	34.0	40.0	45.5
L	35.70	36.0	36.6	37.3

Select the substance which, when dissolved in water, heat is given out. Give a reason (2 mks)

24.

In an experiment to determine the heat of combustion of methanol (CH_3OH) a student used a set up like the one shown in the diagram below. Study the set-up and the data below it and answer the questions that follows

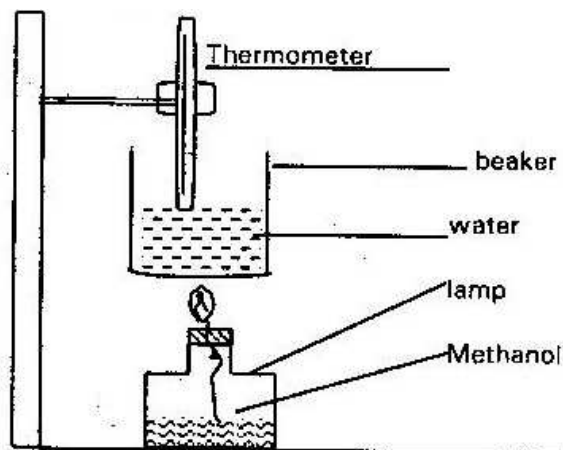

Volume of water = 500cm^3

Final temperature of water = 27.0°C

Initial temperature of water = 20.0°C

Final mass of lamp + methanol = 22.11g

Initial mass of lamp + methanol = 22.98g

Density of water = $1.0/\text{cm}^3$

Heat change = mass x temperature x 4.2j/g/C

- (a) Write an equation for the combustion of methanol (1 mk)
- (b) Calculate
- (i) The number of moles of methanol used in the experiment ($\text{C}=12$),
($\text{O}= 16$) ($\text{H}=1$) (2 mks)

- (ii) Heat change in this experiment
- (iii) The heat of combustion per mole of methanol (2 mks)
- (c) Explain why the value of molar heat of combustion for methanol obtained the theoretical value (2 mks)
- (d) On the axis below sketch an energy diagram for the combustion of methanol

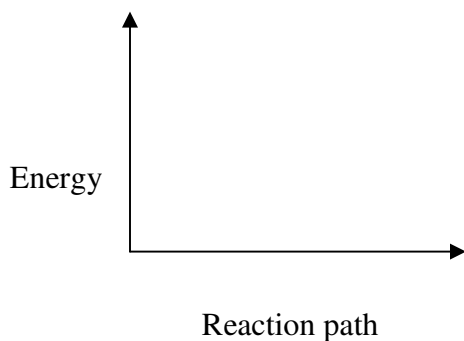

25.

In order to determine the molar heat of neutralization of sodium hydroxide. 100 cm³ of 1m sodium hydroxide and 100 cm³ of 1 m hydrochloric acid both at the same initial temperature were mixed and stirred continuously with a thermometer. The temperature of the resulting solution was recorded after every 30 seconds until the highest temperature of the resulting solution was attained. Thereafter, the temperature of the solution was recorded for a further two minutes

- (a) (i) Why was it necessary to stir the mixture of two solutions
- (ii) Write an ionic equation for the reaction which took place (1 mk)

The sketch below was obtained when the temperature of the mixture were plotted against time.

Study it and answer the questions that follows

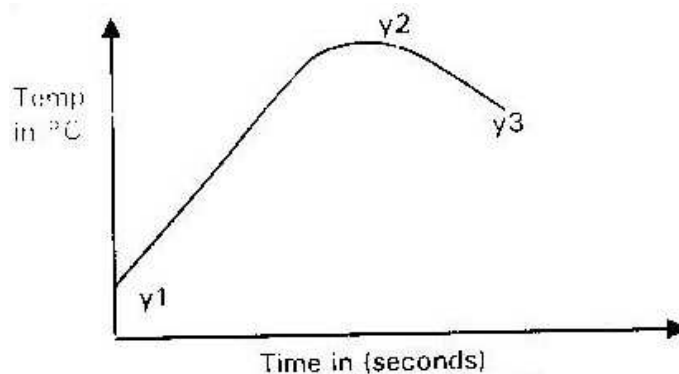

- (I) What is the significance of point Y2 (1 mk)
- (II) Explain why there is a temperature change between points
Y1 and Y2 (1 mk)
Y2 and Y3 (1 mk)
- (III) If the initial temperature for both solutions was 24.5°C and the highest temperature attained by the mixture was 30.9°C . Calculate
- (I) Heat change for the reaction (Specific heat capacity of solution = $4.2\text{J/g}^{\circ}\text{C}$ and the density of the solution = 1.0g/cm^3)
- (II) Molar heat of neutralization of sodium hydroxide (2mks)
- (III) Explain how the value of the molar heat of neutralization obtained in this experiment would compare with the one

that would be obtained if the experiment was repeated using 100 cm^3 of 1M ethanoic acid instead of hydrochloric acid. (2 mks)

- (b) On the grid provided below, draw an energy level diagram for the reaction between hydrochloric acid sodium hydroxide (2 mks)

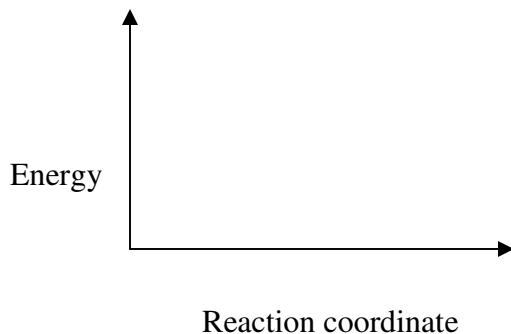

26.

- (a) Distinguish between exothermic and endothermic reaction (2 mks)
- (b) Change of state is either exothermic or endothermic. Name a change of state that is
- (i) Endothermic (1 mk)
 - (ii) Exothermic (1 mk)
- (c) When pure water is heated at 1 atmospheric pressure at sea level, the temperature of the water does not rise beyond 100°C even when continued heating. Explain these observations. (1 mk)

- (d) Study the energy cycle diagram below and answer the questions that follows

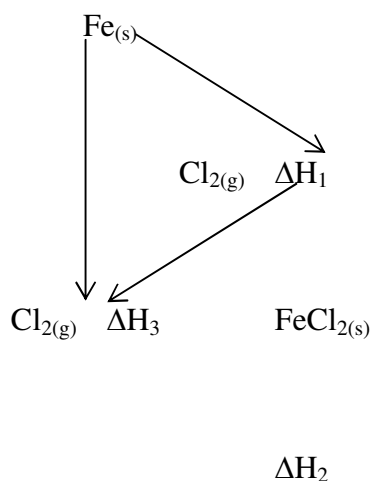

- (i) What does ΔH_1 represents (1 mk)
- (ii) Show the relationship between ΔH_1 , ΔH_2 , and ΔH_3 (3 mks)
- (e) Butane and propane are constituent of cooking gas. Which one produces more energy per mole on combustion? Explain (2 mks)

27.

- (a) In an experiment to determine the molar heat of reaction when magnesium displaces copper. 0.15g of magnesium powder was added to 25 cm³ of 0.2m copper (II) chloride solution was 25⁰C while that of the mixture was 43⁰C.
- (i) Other than increase in temperature, state and explain the observation which were made during the reaction (3 mks)

- (ii) Calculate the heat change during the reaction (Specific heat capacity of the solution = $4. \text{J/g/k}$ and the density of the solution = 1g/cm^3 (2 mks)
- (iii) Determine the molar heat of displacement of copper by magnesium (mg = 24.0)
- (iv) Write the ionic equation for the reaction (1 mk)
- (v) Sketch an energy level diagram for the reaction (2 mks)

28.

- (a) State two factors that should be considered when choosing fuel for cooking (2 mks)
- (b) The diagram below represents a set- up that was used to determine the molar heat of combustion of ethanol

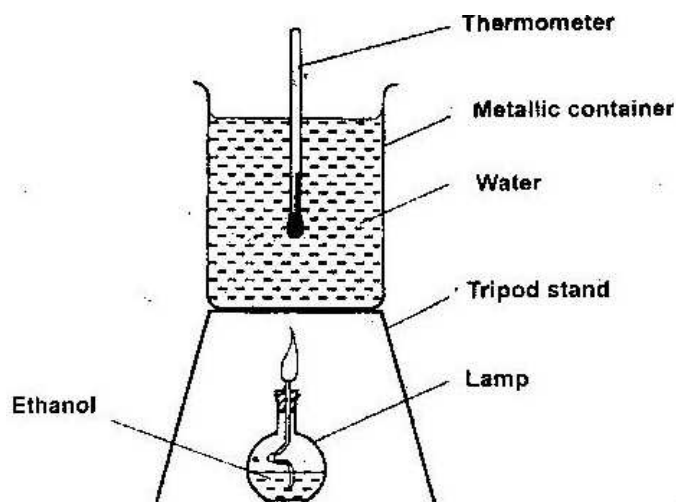

During the experiment, the data given below was recorded

Volume of water	450cm ³
Initial temperature of water	250C
Final temperature of water	46.50C
Mass of ethanol + lamp before burning	125.5g
Mass of ethanol + lamp after burning	124.0g

Calculate the

- (a) Heat evolved during the experiment (Density of water = 1g/cm³), specific heat capacity of water = 4.2 Jg⁻¹ k⁻¹) (2 mks)
- (b) Molar heat of combustion of ethanol (C= 12.0, O = 16.0, H = 1.0) (2 mks)
- (c) Write the equation for the complete combustion of ethanol (1 mk)
- (d) The value of the molar heat of combustion of ethanol obtained in (b) (ii) above is lower than the theoretical value. State two sources of error in the experiment (2 mks)

29.

- (a) Define the standard enthalpy of formation of a substance (1 mk)
- (b) Use the thermochemical equations below to answer the questions that follow

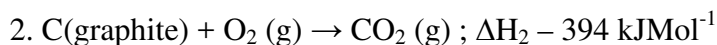
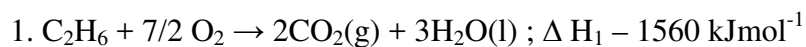

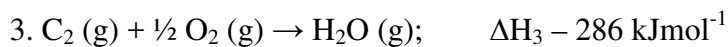

- (i) Name two types of heat changes represented by ΔH_f
- (ii) Draw an energy diagram for the reaction represented by equation 1. (3 mks)
- (iii) Calculate the standard enthalpy of formation of ethane (2 marks)
- (iv) When a sample of ethane was burnt, the heat produced raised the temperature of 500g of water by 21.5K. (Specific heat capacity of water = $4.2 \text{ Jg}^{-1} \text{ K}$).

Calculate the:

I. Heat change for the reaction (2 mks)

II. Mass of ethane that was burnt (relative formula mass of ethane = 30)

30. The heat of combustion of charcoal is 360kJ/mole. Find the amount of charcoal that will produce 30 kJ of energy. (C=12) (1 mk)

31. When 5 grams of propanol ($\text{C}_3\text{H}_7\text{OH}$) is burnt in air, 167 kJ of heat is produced. Calculate the molar heat of combustion of propanol (H=1), (C = 12) (O=16) (2mks)

32. In a class experiment 5.0 of ethanol ($\text{CH}_3\text{CH}_2\text{OH}$) was completely burnt and all the heat evolved was used to heat 500 cm^3 of water from 20°C to 80°C . Given that the specific heat capacity of water is 4.2 J/g/k and the density of water is 1 g/cm^3 .

- (i) Write the equation to show the reaction that takes place when ethanol is burnt (1 mk)
- (ii) Calculate the heat energy observed by water (2 mks)

(iii) Find the molar heat of combustion of ethanol (1 mk)

C= 12 (H= 1) (O= 16)

33. When excess iron filings were placed in 100cm³ of 0.1M copper (II) sulphate solution, this was a temperature rise of 4⁰C. Find the molar heat of reaction. Take specific heat capacity of 4.2j/g/k and density of solution 1.0g/cm³. (3 mks)

34. Study the information in the table below and answer the questions that follows

Bonds	C.H	CL-Cl	C-CL	H-CL
Bond energy	444	244	326	431

Calculate the enthalpy change for the reaction (2 mks)

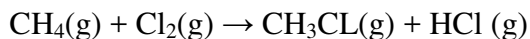

35. The graph below shows part of temperature – time curve obtained when solid naphthalene was heated.

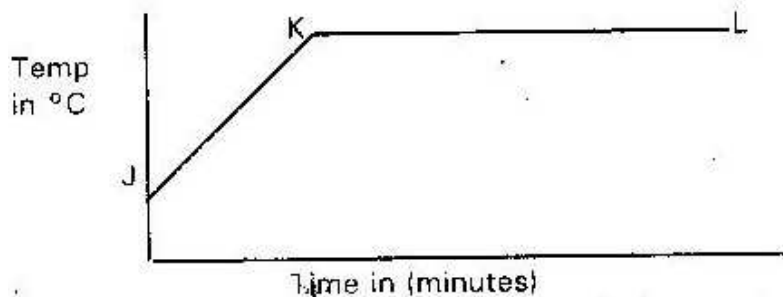

Explain what happen to the naphthalene molecules along the curve

(a)JK

(b) KI

36. Below is an energy level diagram for the combustion of ethanol. Use it to answer the questions that follows

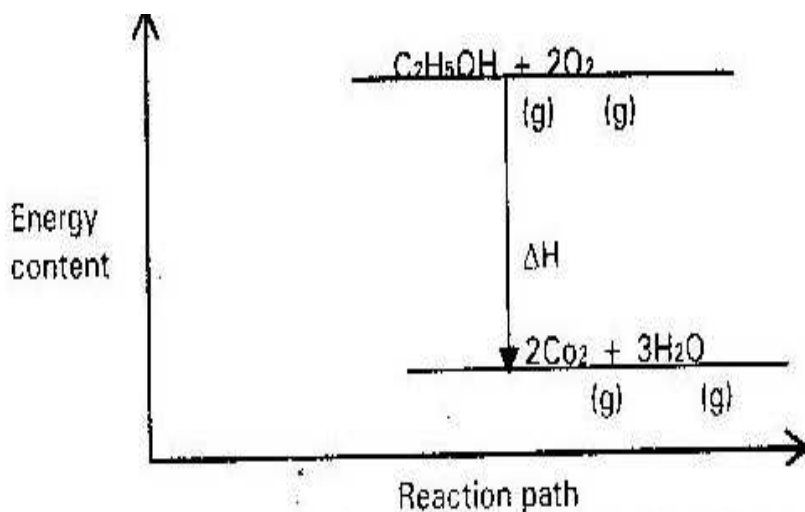

- (i) State whatever the reaction is endothermic or exothermic. Give your reasons (1 mk)
- (ii) What is the sign of ΔH? Give a reason (1 mk)

37. Study the following redox reactions

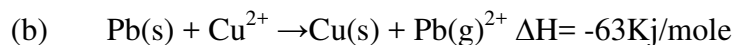
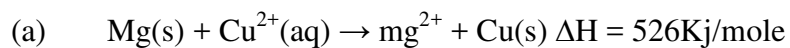

Calculate the amount of heat liberated when

- (i) 0.25 moles of copper is formed in reaction (a) (1 mk)

(ii) 0.5 moles of copper is formed in reaction (b) (1 mk)

38. Given the following values of heat of combustion, calculate the heat of formation of ethane (C₂H₄)

ΔH_C ethane = -1432 KJ/mole

ΔH_C hydrogen = -272kJ/mole

ΔH_C carbon = 406 kJ/mole

39. The heat of neutralization of a strong acid is usually 57.4 kJ/mole, whereas that of a weak acid usually less than 57.4 kJ/mole. Explain

TOPIC 2

RATE OF REACTION

1.

The table below gives factors which affect the value of reaction

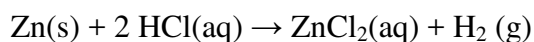

Complete the table to show how the factors given affect the rate of reaction and give an explanation (2 mks)

Factors	Effect on rate	Explanation
Using Zinc powder instead of granules		
Heat the reactants		

2.

The equation below represents two processes that take place without any change in temperature

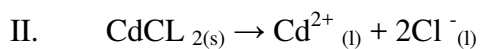
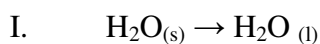

(a) Explain why although heat is required for each of the process to take place the temperature remains constant in both processes (1 mk)

(b) Which of the two has a higher enthalpy change (H)? Give a reason

(2 mks)

3. The curves below represents the changes in the concentrations of substances “E” and “F” with time in the reaction

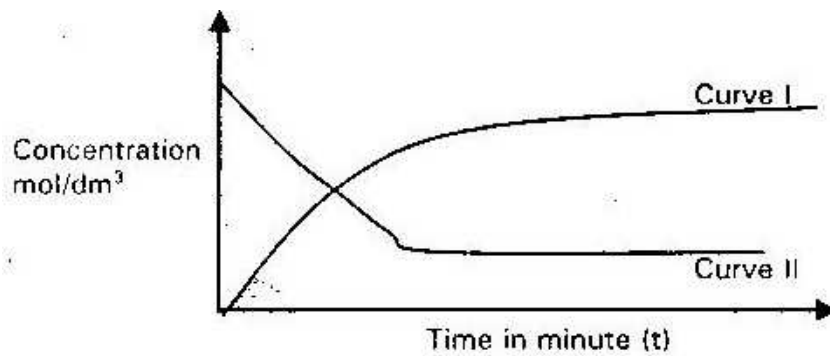

- (i) Which curve represents the change in the concentration of substance F?
Give a reason (2 mks)
- (ii) Give a reason for the shapes of the curves after t minutes

4.

The curves shown below were obtained when two equal volumes of hydrogen peroxide of same concentration were allowed to decompose separately in one case, manganese (IV) oxide was added to hydrogen peroxide.

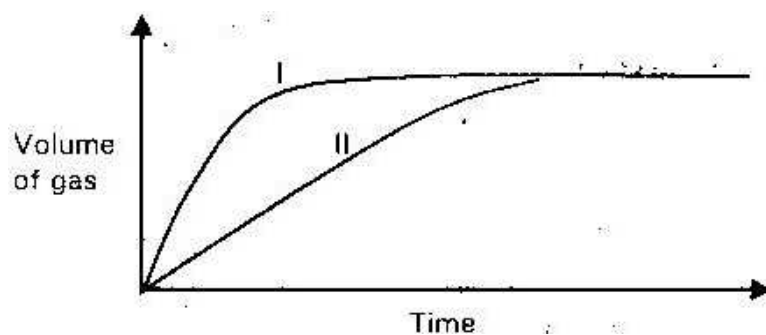

Which curve represents the decomposition of hydrogen peroxide with manganese (IV) oxide? Explain (2 mks)

5.

State and explain how the rate of reaction between zinc granules and steam can be increased. (2 mks)

6.

The table below gives three experiments on the reaction of excess sulphuric acid and 0.5g of zinc done under different condition. In each case the volume of gas was recorded at different time intervals.

Experiment	Term of zinc	Conclusion of sulphuric acid
I	Powder	0.8m
II	Powder	1.0m
III	Granules	0.8m

On the same axis draw and label the three curves that could be obtained from such results (3 mks)

7.

During the production of hydrogen iodide, hydrogen reacts with iodine according to the equation

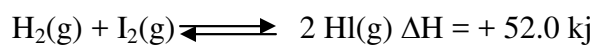

Explain how the following would affect the yield of hydrogen iodide

- (a) Increase in temperature (1 mk)
- (b) Decrease in pressure (1 mk)

8.

Ammonia can be converted to nitrogen (II) oxide as shown in the equation below

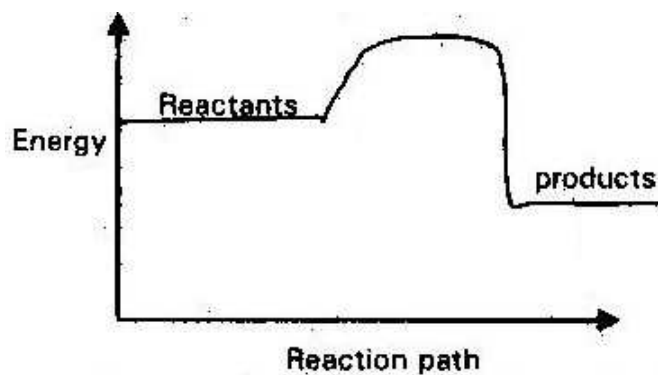
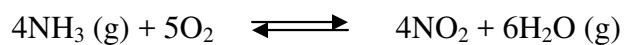

The energy level diagram for the reaction is given above

- (a) Explain how an increase in temperature would affect the yield of Nitrogen (II) oxide (2 mks)

9.

The decomposition of calcium carbonate can be represented by the equation

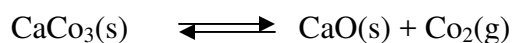

Explain how an increase in pressure would affect the equilibrium position

(2 mks)

10.

In the Haber process, the optimum yield of ammonia obtained when a temperature of 450°C a pressure of 200 atmospheres and iron catalyst are used

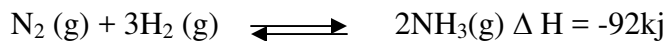

- (a) How would the yield of ammonia be affected if the temperature raised to 600°C. (2 mks)
- (b) Give one use of ammonia (1 mk)

11.

The reaction between a piece of magnesium ribbon with excess 2M hydrochloric acid was investigated at 25°C by measuring the volume of hydrogen gas produced as the reaction progressed. The sketch below represents the graph that was obtained

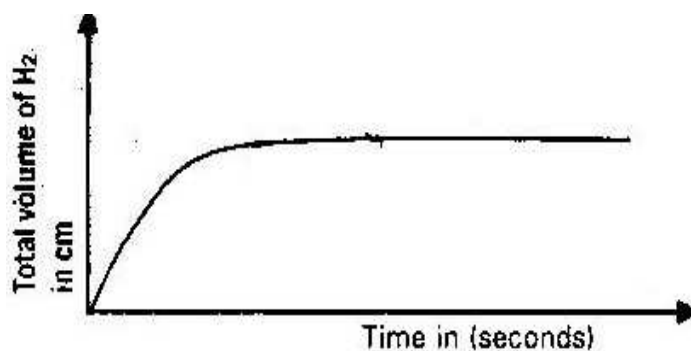

- (a) Name one piece of apparatus that may be used to measure the volume of hydrogen gas produced (1 mk)
- (b) On the same diagram. Sketch the curve that would be obtained if the experiment was repeated at 35°C. (2 mks)

12.

The sketch below shows the rate at which substance “H” is converted to “J” Study it and answer the question that follows

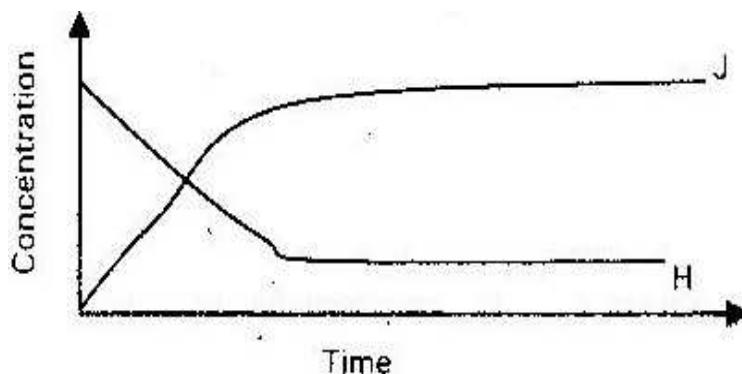

Why do the two curves become horizontal after some time (1 mk)

13.

(a) What conditions is necessary for an equilibrium to be established? (1 mk)

(b) When calcium carbonate is heated, the equilibrium shown below is established



How would be the position of the equilibrium be affected if a small amount of dilute potassium hydroxide is added to the equilibrium mixture? Explain (2 mks)

14.

Equal volume of 1m monobasic acids I and “M” were each reacted with excess magnesium turnings. The table below shows the volumes of the gas produced after one minutes.

Acid	Volume of gas (cm ³)
L	40
M	100

Explain the difference in the volumes of the gas produced (2 mks)

15.

In a closed system, aqueous iron (III) chloride reacts with hydrogen sulphide gas as shown in the equation below

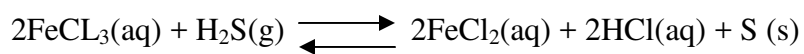

State and explain the observation that would be made if dilute hydrochloric acid is added to the system at equilibrium (2 mks)

16.

A certain mass of a metal E1 reacted with excess dilute hydrochloric acid at 25⁰C. The volume of hydrogen gas liberated was measured after every 30 seconds. The results were presented as shown in the graph below

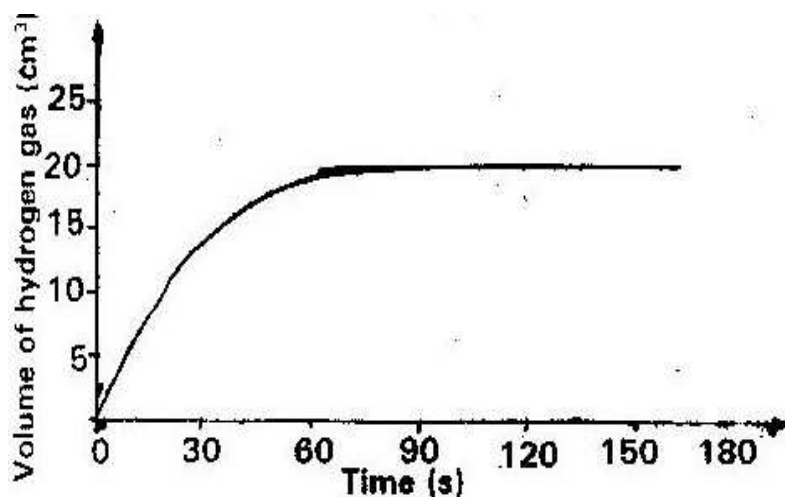

- (a) Name one piece of apparatus that may have been used to measure the volume of the gas liberated. (1 mk)
- (b) (i) On the same axis, sketch the curve that would be obtained if the experiment was repeated at 35⁰C (1 mk)
- (ii) Explain the shape of your curve in b(i) above (1 mk)

17.

Sodium thiosulphate reacts with dilute hydrochloric acid according to the following equation

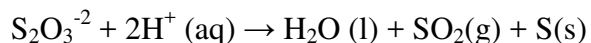

In an experiment to study how the rate of reaction varies with concentration, 10cm³ of 0.4M sodium thiosulphate was mixed with 10 cm³ of 2M hydrochloric acid in a flask. The flask was then placed on white paper marked with a cross (x). The time taken for the cross (x) to become invisible when viewed from above was noted and recorded in the table below. The experiment was repeated three times at the same temperature using the volumes in the table below.

Experiment	Volume (in cm ³ of 0.4m thiosulphate	Volume of water cm ³	Volume of 2mHcl	Time in seconds
1	10.0	0	10	16
2	7.5	2.5	10	23
3	5.0	5.0	10	32
4	2.5	7.5	10	72

- (a) (i) Plot a graph of the volume of thiosulphate (vertical axis) against time taken for the cross (x) to become invisible (3 mks)
- (ii) From the graph, determine how long it would take for the cross to become invisible if the experiment was done
- I. Using 6cm³ of the 0.4m thiosulphate solution (1 mk)
- II. Using 6cm³ of 0.2 m thiosulphate solution. Explain (1 mk)
- (b) (i) Using the values for experiment 1. Calculate

- (I) Moles of thiosulphate used
- (II) Moles of hydrochloric acid used
- (ii) (Which of the time reactants in experiment 1 controlled the rate of the reaction? Explain
- (c) Give two precautions which should be taken in the experiments above to ensure that constant results are obtained. (2 mks)

18.

The table below gives the volumes of the gas produced when different volumes of 2m hydrochloric acid were reacted with 0.6g of magnesium powder at room temperature.

Volume of hydrochloric acid	Volume of gas cm ³
0	0
10	240
20	480
30	600
40	600
50	600

- (a) Write an equation for the reaction between magnesium and hydrochloric acid (1mk)
- (b) On the grid provided plot a graph of the volume of gas produced (vertical axis) against the volume of acid added. Note that before the reaction produced is directly proportional to the volume of acid added (3mks)
- (c) From the graph, determine:

- (i) The volume of the gas produced if 12.5 cm³ of 2M hydrochloric acid had been used
- (ii) The volume of 2M hydrochloric acid which reacted completely with 0.6 g of magnesium powder. (1mk)
- (c) (i) State and explain the effect on the rate of production of the gas if 0.6g of magnesium ribbon were used instead of magnesium powder (2mks)
- (ii) 3M hydrochloric acid was used instead of 2M hydrochloric acid
- (d) Given that one mole of the gas occupies 24000 cm³ at room temperature, calculate the relative atomic mass of magnesium (3mks)

19.

In an experiment to study the rate of reaction between duralumin (alloy of aluminium, magnesium and copper) and hydrochloric acid 0.5g of the alloy were reacted with excess 4M hydrochloric acid. The data in the table below were recorded; use it to answer the question that follows:

Time (minutes)	Total volume of gas cm ³
0	0
1	220
2	410
3	540
4	620
5	640
6	640
7	640

- (a) (i) From the graph determine the volume of gas produced at the end of 2 ½ minutes (1 mk)
- (b) Determine the rate of reaction between 3rd and 4th minutes (1 mk)
- (c) Give a reason why some solid remained at the end of the experiment (2 mks)
- (d) Given that 2.5m³ of the total volume of the gas was magnesium and aqueous hydrochloric acid, calculate the percentage mass of aluminium present in 0.5g of an alloy. (Al = 27) (H=1)
- (e) State the properties of duralumin that make it more suitable than pure aluminum in aeroplane construction. (2 mks)

20.

Excess marble chips (calcium carbonate) was put in a beaker containing 100 cm³ of dilute hydrochloric acid. The beaker was then placed on a balance and the total loss in mass recorded after every two minutes as shown in the table below

Time (minutes)	0	2	4	6	8	10
Total loss in mass (g)	0	1.8	2.45	2.95	3.2	3.3

- (a) Why was there less in mass (1 mk)
- (b) Calculate the average rate of loss in mass between
- (i) 0 and 2 minutes (1 mk)
- (ii) 6 and 8 minutes (1 mk)
- (iii) Explain the difference in the average rates of reaction in (b) (i) and (ii) above (2 mks)
- (c) Write the equation for the reaction which takes place in the beaker (1 mk)

- (d) State three ways in which the rate of the reaction above could be increased. (3 mks)
- (e) The solution in the beaker was evaporated to dryness explain what would happen if the beaker and its contents were left in the laboratory overnight (2 mks)
- (f) Finally some water was added to the contents of the beaker when aqueous sodium sulphate was added to the content of the beaker a white precipitate was formed
- (i) State one use of the substances identified in (f)(i) above

21.

The table below shows the volumes of nitrogen (IV) oxide gas produced when different volumes of 1m nitric acid were each reacted with 2.07g of lead at room temperature.

Volume of 1m nitric acid	Volume of nitrogen (IV) oxide gas cm ³
5	60
15	180
25	300
35	450
45	420
55	480

- (a) Give a reason why nitric acid is not used to prepare hydrogen gas (1 mk)

- (b) Explain how the rate of reaction between lead and nitric acid would be affected if the affected if the temperature of the reaction mixture is raised
(2 mks)
- (c) On the grid provided below plot a graph of the volume of the gas produced vertical axis against the volume of acid (3 mks)
- (d) Using the graph, determine the volume of
- Nitrogen (IV) oxide produced when 30 cm^3 of 1M nitric acid were acted with 2.07g of lead
 - 1M nitric acid which would react completely with 2.07g of lead
(1mk)
- (e) Using the answer in d (ii) above determine
- The volume of 1 m nitric acid that would react with one mole of Pb/lead (Pb = 207) (2 mks)
 - The volume of nitrogen (IV) oxide gas produced when one mole of lead reacts with excess 1M nitric at room temperature
- (f) Calculate the number of moles of
- 1M Nitric acid that reacted with one mole of lead
 - Nitrogen (IV) oxide produced when one molar of lead were reacted with excess nitric acid. Molar gas volume = 24000 cm^3 (1 mk)
 - Using the answer in (21) (i) and (ii) above write the equation for the reaction between lead and nitric acid given that one mole of lead nitrate and two moles of water were also produced. (1 mk)

22.

- (a) Methanol is manufactured from carbon (IV) oxide and hydrogen gas according to the equation

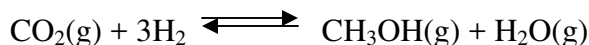

The reaction is carried out in the presence of a chromium catalyst at 700K and 30kpa. Under these conditions an equilibrium is reached when 2% of the carbon (IV) oxide is converted to methanol

- (i) How does the rate of the forward reaction compare with that of the reverse reaction when 2% of the carbon (IV) oxide is converted to methanol?

(1mk)

- (ii) Explain how each of the following would affect the yield of methanol

- Reduction in pressure (2 mks)
- Using a more efficient catalyst (2 mks)

- (iii) If the reaction is carried out at 500K and 30 kpa, the percentage of carbon (IV) oxide converted to methanol is higher than 2%

(I) What is the sign of ΔH for the reaction? Give a reason (2mks)

(II) Explain why in practice the reaction is carried out at 700J but NOT at 500K (1 mk)

- (b) Hydrogen peroxide decomposes according to the following equation

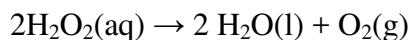

In an experiment, the rate of decomposition of hydrogen peroxide was found to be $6.0 \times 10^{-8} \text{ mol dm}^{-3}\text{S}^{-1}$

- (i) Calculate the number of moles per dm^3 of hydrogen peroxide that had decomposed within the first 2 minutes (2 mks)
- (ii) In another experiment the rate of decomposition was found to be $1.8 \times 10^{-7} \text{ mol dm}^{-3}\text{S}^{-1}$. The difference in the two rates could have been caused by addition of a catalyst, State giving reasons one other factor that may have caused the difference in the two rates of decomposition. (2 mks)

23.

- (a) (i) State the Le chatelier's principle (1 mk)
- (ii) Carbon (II) oxide gas reacts with steam according to the reaction;

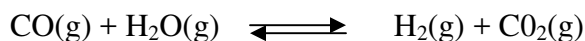

- What would be the effect of increasing the pressure of the system at equilibrium? Explain (2 mks)
- (iii) When the reaction in (ii) above was carried out at lower temperature, the yields of hydrogen and carbon (IV) oxide increased. What is the sign of ΔH for the reaction? Explain (2mks)
- (b) The table below gives the volume of oxygen gas produced at different times when hydrogen peroxide decomposed in the presence of a catalyst.

Time (sec)	0	10	20	30	40	50	60
Volume of oxygen (cm^3)	0	66	98	110	119	120	120

- (i) Name the catalyst used for this reaction (1 mk)
- (ii) On the grid provided. Draw the graph of volume of oxygen gas produced (vertical axis) against time.

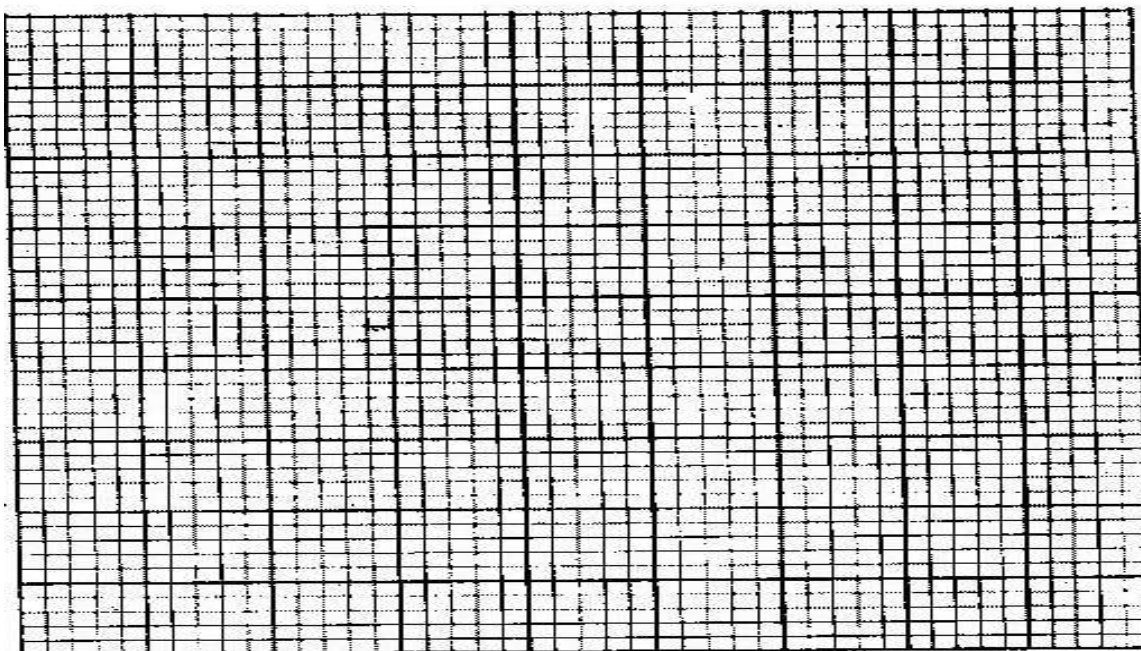

(iii) Using the graph determine the rate of decomposition of hydrogen peroxide after 24 seconds (2 mks)

(iv) Give a reason why the total volume of oxygen gas produced after 50 seconds remains constant (1 mk)

24. Define the term rate of reactions (1 mk)

25. State two methods used to measure rate of reactions (2mks)

26. When a metal oxide of element “w” react with hydrogen, the equation for the equation for the reaction is

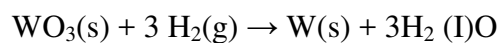

Comment on the reactivity of element “W” with respect to hydrogen (2mks)

27. 7.5g of calcium carbonate was placed in a conical flask containing 50cm³ of dilute hydrochloric acid. The flask kept at constant temperature and the volume of carbon (IV) oxide gas evolved was measured at 20 minutes intervals.

Not all the calcium carbonate was used up during the reaction the results were recorded in the table below

Time from start of reaction (minutes)	Volume of Co2 evolved cm ³
0	0
20	555
40	810
60	695
80	1000
120	1020

- (a) Write an equation for the reaction between calcium carbonate and hydrochloric acid (1 mk)
- (b) Plot a graph volume of carbon (IV) oxide produced against time (minutes) (3 mks)
- (c) What volume of carbon (IV) oxide were evolved during the 20th minutes intervals (20- 40) minutes (1 mk)
- (d) Why was there no increase in volume of the gas evolved after 100 minutes? (1 mk)
- (e) Calculate the mass of 11. 2 cm³ of carbon (IV) oxide gas evolved at stp: molar gas volume = 22.4 dm³
- (f) Determine the mass of calcium carbonate which had reacted after 120 minutes

(1 mk)

28. Consider the equilibrium reaction below

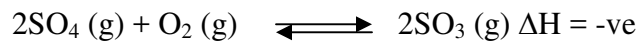

Which of the following will increase the yield of sulphur (vi) oxide

- Addition of catalyst
- Increase in pressure
- Increase in temperature
- Doubling the volume of the system (1 mk)

29. (a) Why does the rate of reaction

- (i) Increase with increase in temperature (1 mk)
- (ii) Increase with use of a suitable catalyst (1 mk)

(b) The equation for gaseous reaction is

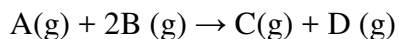

State the effect of the following on rate of reaction

- (i) The pressure of "B" is doubled but of A is the same (1 mk)
- (ii) The amount pressure of both A and B are doubled (1 mk)
- (iii) The amount of A and B remain unchanged but an inert gas is added to double the over all pressure

30. Below is a graph of the volume of oxygen collected (cm^3) against time when powdered and lump of manganese (IV) oxide were used to decompose hydrogen peroxide

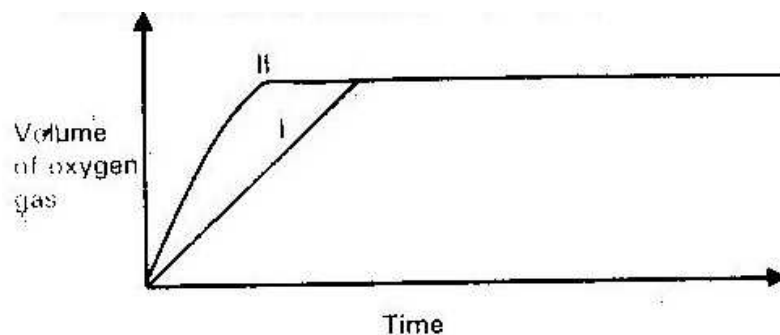

Which one of the curves correspond to the results obtained by using powdered manganese (IV) oxide. Give reasons (2 mks)

31. Consider the following reaction

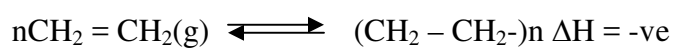

What conditions favours the process (2 mks)

32. Consider the reaction

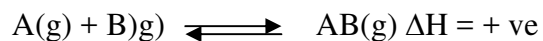

Draw, an energy level diagram for this reaction, when un-catalyzed and when catalyzed (2 mks)

33. For the following gaseous reaction



What is the effect on the rate if the?

- (a) Volume of the total reactants is doubled (1 mk)
- (b) Temperature is doubled (1 mk)

TOPIC 3

ELECTROCHEMISTRY 1 AND 2

1.

A student set up an experiment as shown in the diagram below

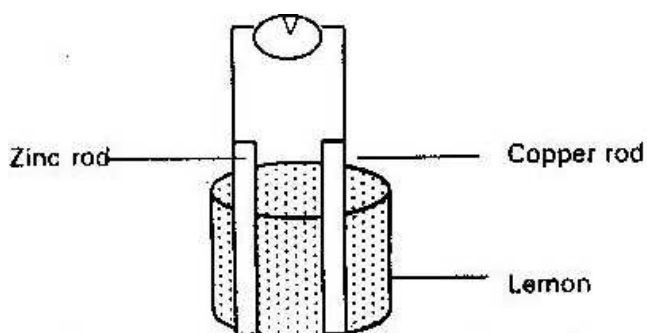

- (a) Draw an arrow on the diagram to indicate the direction of the electron flow. Explain your answer (2 mks)
- (b) What would be observed on the voltmeter (v) if both rods were Zinc rods?

2.

Write an equation for the process that takes place at the anode during electrolysis of aqueous sodium sulphate solution using platinum electrodes (1mk)

3.

3.8g of metal M were deposited when a molten salt of M was electrolyzed by passing a current of 0.6 amps for 90 minutes. Relative atomic mass of M= 226:

1. Faraday = 96500 coulombs)

(a) Calculate the amount of electricity in coulomb

(i) Needed to deposit 3.8g of metal M (1mk)

(ii) Needed to deposit 3.8g of metal M (1mk)

(iii) Deduced the charge on the ion of M (1 mk)

4.

Study the set up below and answer the questions that flows

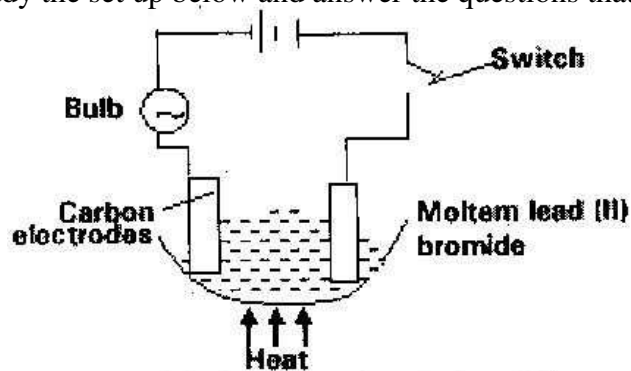

State and explain the observations that would be made when the circuit is completed (3 mks)

5.

Explain the following observation

A chloride dissolves in water to form an electrolyte while the same chloride dissolves in methyl benzene to form non- electrolyte (2 mks)

6.

Explain why it is not advisable to use aqueous sodium chloride solution as the salt bridge in electrochemical cell formed between half cells.



7.

Aqueous potassium sulphate was electrolyzed using platinum electrodes in a cell

- Name the products formed at the cathode and anode (1 mk)
- How does the concentration of electrolyte change during electrolysis?
- Why would it not be advisable to electrolyte aqueous potassium sulphate using metal electrodes?

8.

Use the information below to answer the questions that follows

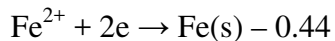
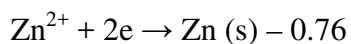

- Calculate the E^{Q} value for the electrochemical cell represented below



- Give a reason why aluminium metal would protect iron from rusting better than zinc metal (1 mk)

9.

The set up below was used to electrolyze aqueous copper (II) sulphate

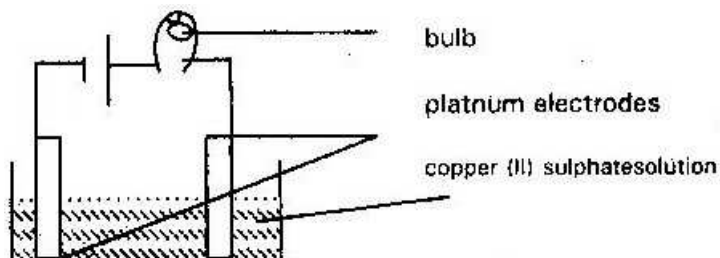

(a) Explain why the bulb light brightly at the beginning of the experiment and become dim after sometime. (2 mks)

(b) Write an ionic equation for the reaction that took place at the cathode (1 mk)

10.

Use the cell representation below to answer the questions that follow

(a) Write the equation for the cell reaction (1 mk)

(b) If the e.m.f of the cell is + 0.30v and Eq value of $\text{Fe(a)}^{2+} / \text{Fe(s)}$ is 0.44V. Calculate the E° value of $\text{Cr(a)}^{3+} / \text{CV(s)}$ (2 mks)

11.

When amount of 1.5 amperes was passed through a cell containing M^{3+} ions of metal M for minutes the mass of the cathode increased by 0.26g. (Faraday = 96500 coulombs)

- (a) Calculate the quantity of electricity used (1 mk)
- (b) Determine the relative atomic mass of metal “m” (2 mks)

12.

An element “P” has a relative atomic mass of 88. When a current of “P” for 32 minutes and 10 seconds 0.44g of “p” were deposited at the cathode.

Determine the change on an ion of “p”

13.

The set up below was used to electroplate a metallic spoon. Study it and answer the question that follows

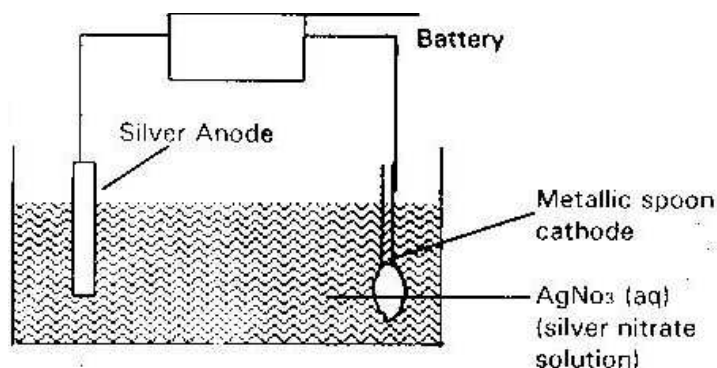

- (a) Write an ionic equation for the reaction that occurred at the cathode (1 mk)
- (b) State and explain what happen to the anode (1 mk)

14.

During purification of copper by electrolysis 1.48g of copper were deposited when a current was passed through aqueous for 2 ½ hrs

Calculate the amount of current that was passed (3 mks)

(CU = 63:5) (1 Faraday = 96,500 Coulombs)

15.

A strip of metal “Q” was dipped into a solution of copper (II) sulphate and allowed to stand overnight. Given that

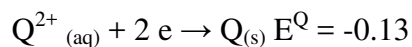

(a) State the observations which were made (2 mks)

(b) Give a reason for your answer in 19 (i) above (2 mks)

16.

The diagram below represent the set ups that were used to a study the effect of an electric current on pure water and dilute sulphuric acid.

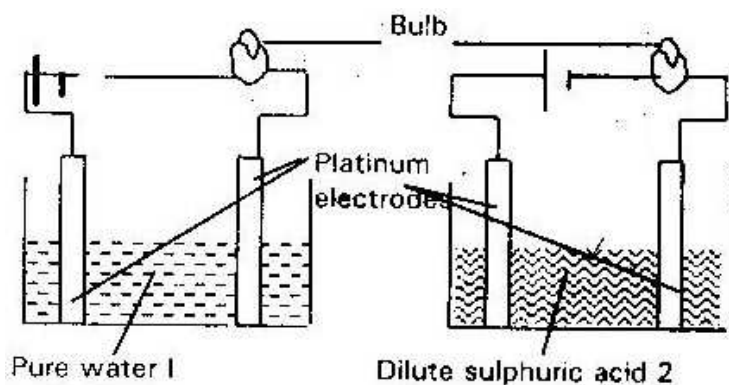

State and explain the observations made when each experiment was started

(3 mks

17.

In an experiment to investigate the conductivity of substance a student used the set up shown below

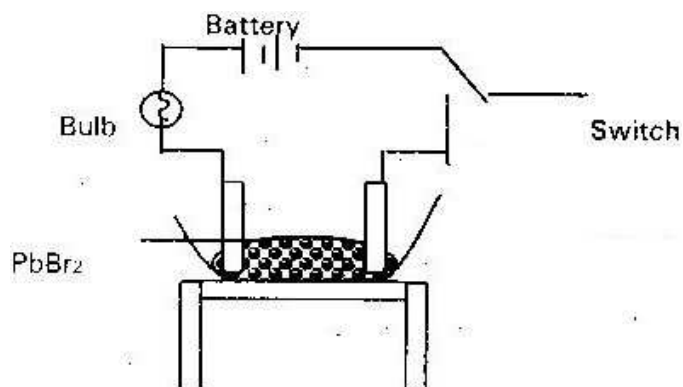

Student noted that the bulb did not light

- What had been omitted in the set up (1 mk)
- Explain why the bulb light when the omission is occurred (2 mks)

18.

When a current of 0.82A was passed for 5 hours through an aqueous solution of metal "Z" 2.65g of metal were deposited

Determine the change on the ions of metal (A faraday = 96,500 coulomb) relative atomic mass of Z = 52 (2 mks)

19.

Study the standard reduction potential given below and answer the questions that follow. The letters are not actual symbols of the elements

Actual symbols of elements

EQ values

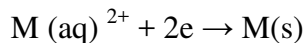

-0.76V

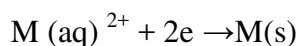

- 2.36V

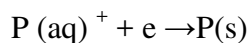

-0.80V

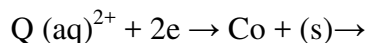

- 0.14V

- (a) The standard reduction potential for Fe^{2+} is 0.44V. Select the element which would best protect iron from rusting (1 mk)
- (b) Calculate the E^Q value for the cell $M(s) / M^{2+} (a) // P^+(aq) P(s)$ (2mks)

20.

- (a) Use the information given below to draw a labeled diagram of an electrochemical cell that can be constructed to measure the electromotive force between G and J.

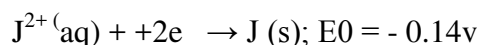

- (b) Calculate the E^0 value for the cell constructed in (a) above. (1mk)

21.

- (a) When brine is electrolyzed using inert electrodes, chlorine gas is liberated at the anode instead of oxygen. Explain this observation. (2mks)
- (b) Name the product formed at the cathode. (1mk)

22.

During the electrolysis of aqueous silver nitrate, a current of 0.5A was passed through the electrolyte for 3 hours.

- (a) Write the equation for the reaction which took place at the anode. (1mk)
- (b) Calculate the mass of silver deposited ($A_g = 108$; $1F = 965000$) (2mks)

23.

(a) The following are half-cell reaction and their reduction potentials,

E^0 (Volts)

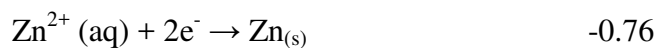

(b) Write the cell representation for the electrochemical cell that would give the highest E^0 (1mk)

(c) State and explain the observations made when a copper rod is placed in a beaker containing silver nitrate solution. (2mks)

24.

The diagram below represents an experiment that was set up to investigate movement of ions during electrolysis.

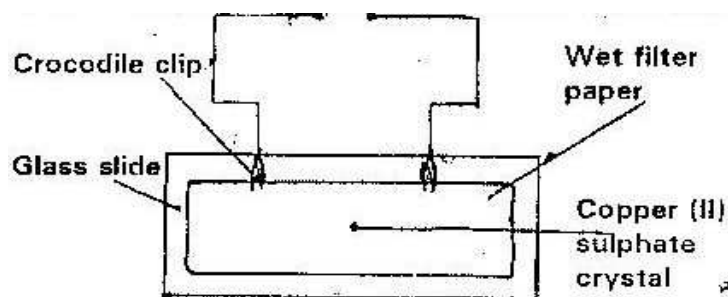

When the circuit was completed, it was noticed that a blue colour spread towards the right

- (a) Explain this observation (2mks)
- (b) Write the equation for the reaction that occurred at the anode (1 mk)

25.

- (a) The table below gives reduction potentials obtained when the half cells for each of the metals represented by J, K, L, M and N were connected to a copper half of cells as the reference electrodes.

Metals	Reduction potential (vol/s)
J	-1.10
K	-0.47
L	-0.00
M	+ 0.45
N	1.16

- (i) What is the metal “L” likely to be? Give a reason (1 mk)
- (ii) Which of the metals cannot be displaced from solution of its salt by any other metal in the table give a reason (2mks)

- (iii) Metal “K” and “M” were connected to form a cell as shown the diagram below

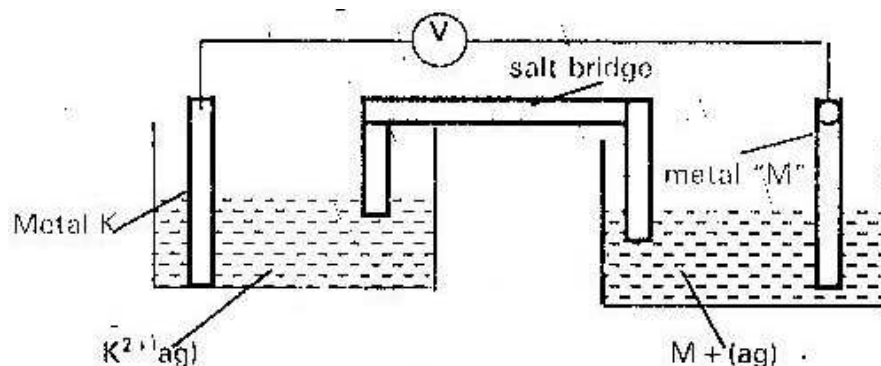

- (i) Write the equation for the half cell reaction that occur at metal K electrode (1 mk)
- (ii) If the salt bridge is filled with saturated sodium nitrate solution, how does it help to complete the circuit (2mks)
- (b) When electric current is passed through copper (II) sulphate solution for several hours as shown in the diagram, a gas that relights a glowing splint is produced at electrode “C”

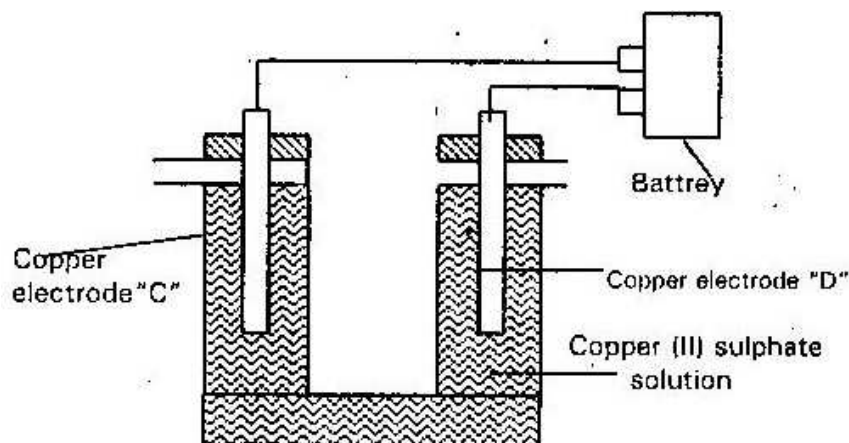

- (i) Which of the electrode is the cathode? Give a reason (2mks)
- (ii) Write an equation for the formation of the gas at electrode “D”
- (iii) State and explain the observations that would be made
 - I. At electrode “D” (1 mk)
 - II. In the copper (II) sulphate solution (1 mk)

26.

The extraction of aluminium from its ore takes place in two stages, purification stage and electrolysis stage. Below shows the set up for the electrolysis stage

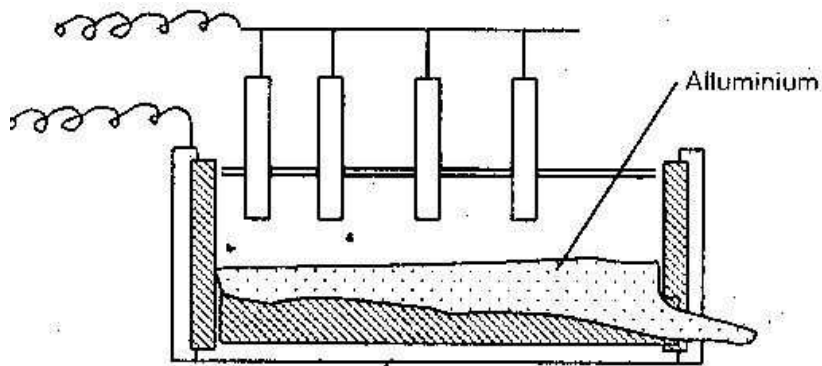

- (a) (i) Name the ore from which aluminum is extracted (1 mk)
- (ii) Name one impurity which is removed at the purification stage (1 mk)
- (b) (i) Label on the diagram each of the following
 - I. Anode
 - II. Cathode
 - III. Region containing electrolyte

- (ii) The melting point of aluminium oxide is 20540C, but the electrolysis is carried out at between 800 C and 9000C
- I. Why is not carried out at 20500C (2mks)
 - II. What is done to lower the temperature (1 mk)
- (iii) The aluminium which is produced is tapped off as a liquid. What does this suggest about its melting point?
- (c) A typical electrolysis cell uses a current of 40,000 amperes. Calculate the mass (in kg) of aluminium produced in one hour (Al = 27) Faraday = 96,500 coulombs (3mks)

27.

Use the standard electrode potential for A, B, C, D and F given below to answer the questions that follows. The letters do not represent the actual symbols of the elements

	E^Q volts
$A(aq)^{2+} + 2e \rightarrow A(s)$	- 2.90V
$B(aq)^{2+} + 2e \rightarrow B(s)$	- 2.38V
$C(aq)^+ + e \rightarrow \frac{1}{2} C_2$	- 0.00V
$D(aq)^{+2} + 2e \rightarrow D(s)$	+ 0.34V
$\frac{1}{2} Fe_2 + e \rightarrow F(aq)$	+ 2.87V

- (i) Which element is likely to be hydrogen? Give a reason for your answer (2mks)
- (ii) What is E^Q value for the strongest reducing agent? (1 mk)

- (iii) In the space provide, draw a labeled diagram of the electrochemical cell that would be obtained when a half cells of element “B” and “D are combined (3mks)
- (iv) Calculate the EQ value of the electrochemical cell constructed in (iii) above (1 mk)

28.

The diagram below shows the extraction of sodium metal using the down cell

Study it and answer the questions that follows

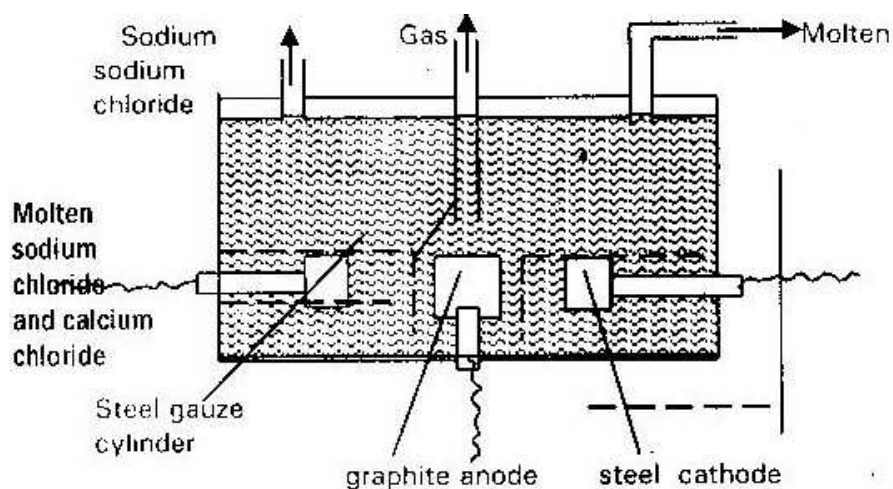

- (i) Explain why in this process the sodium chloride is mixed with calcium chloride (2 mks)
- (ii) Why is the anode made of graphite and not steel? (1 mk)
- (iii) State two properties of sodium metal that make it possible for it to be collected as shown in the diagram (2 mks)
- (iv) What is the function of steel gauze cylinder? (1 mk)
- (v) Write ionic equation for the reactions which take place at
- I. Cathode (1 mk)

II. Anode (1 mk)

(vi) Give one industrial use of sodium metal (1 mk)

29.

The set up below was used during the electrolysis of aqueous magnesium sulphate using inert electrodes

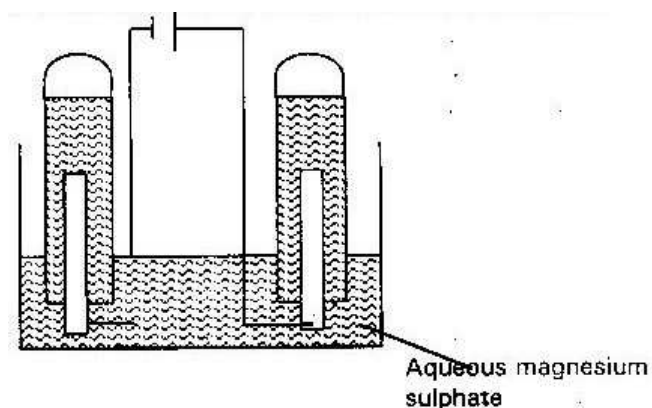

(i) Name a suitable pair of electrodes for this experiment (1 mk)

(ii) Identify the anions and cations present in the solution (2mks)

(iii) On the diagram label the cathode (1 mk)

(iv) Write ionic equation for the reaction that took place at the

I: Anode (1 mk)

II. Cathode (1 mk)

30.

- (a) The diagram below represents a mercury cathode cell that can be used in the industrial manufacture of sodium hydroxide. Study it and answer the question that follows

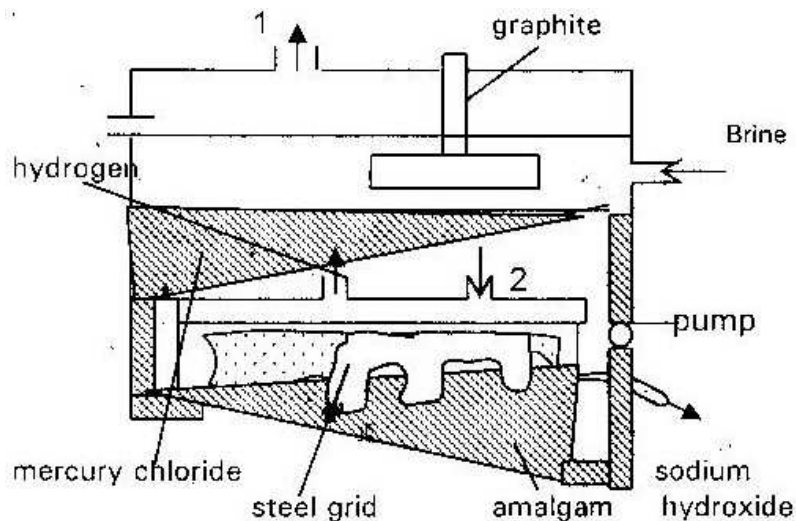

- i. Name the
- I: Raw material introduced at "2" (2mks)
- II: Another substance, that can be used in the cell instead of graphite (1mk)
- ii. Identify the by products that come out at I (1 mk)
- iii. Give
1. One use of sodium hydroxide (1 mk)
2. Two reasons why mercury recycled (1 mk)
- (b) A current of 1000 amperes was passed through the cell for five (5) hours
- i. Write equation for

- I. The reaction that occurred at the mercury cathode (1 mk)
- II. The reaction in which sodium hydroxide was produced (1 mk)

- ii. Calculate the mass of sodium hydroxide that was produced (Na= 23) (O = 16) (H=1.0) Faraday = 96500 coulombs (4mks)

31.

- (a) Study the standard electrode potentials for the half cells given below and answer the questions that follows. The letters do not represent the actual symbols of the elements

	E volts
$N^+_{(av)} + e^- \rightarrow N$	-2.92
$J^+_{(av)} + e^- \rightarrow J$	+0.52
$K^+(aq) + e^- \rightarrow \frac{1}{2} Kg$	0.00
$\frac{1}{2} G(g) + e^- \rightarrow G^-(ag)$	+1.36
$M^{2+}(g) + 2 e^- \rightarrow m(g)$	-0.44

- i. Identify the strongest oxidizing agent: Give a reason for your answer
- ii. Which two half cells would produce the highest potential differences when combined? (1 mk)
- iii. Explain whether the reaction represents below can take place (2mks)
- $$2M^- + N \rightarrow 2N + M^{2+}$$
- (av) (s) (s) (aq)

- (b) 100 cm^3 of 2m sulphuric acid was electrolyzed using the set up represented by the diagram below

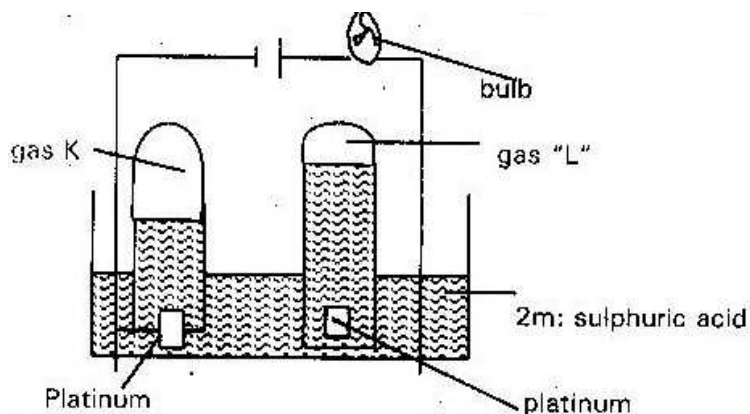

- i. Write an equation for the reaction that produce gas "L" (1 mk)
- ii. Describe how gas "k" can be identified (1 mk)
- iii. Explain the differences in
 - (a) The volume of gases produced at the electrodes
 - (b) Brightness of the bulb if 100 cm^3 of 2m ethanoic acid was used in place of sulphic acid (2mks)

32.

The table below gives the standard electrode potentials for the metals represented by letters D, E, F & G. study it and answer the questions that follows

Metals	Standard electrical potential (volts)
D	-0.13
E	+ 0.85
F	+ 0.34
G	- 0.76

- (a) Which metal can be displaced from a solution of its salt by all the other metals in the table? Give a reason
- (b) Metal "F" and "G" was connected to form a cell as shown in the diagram

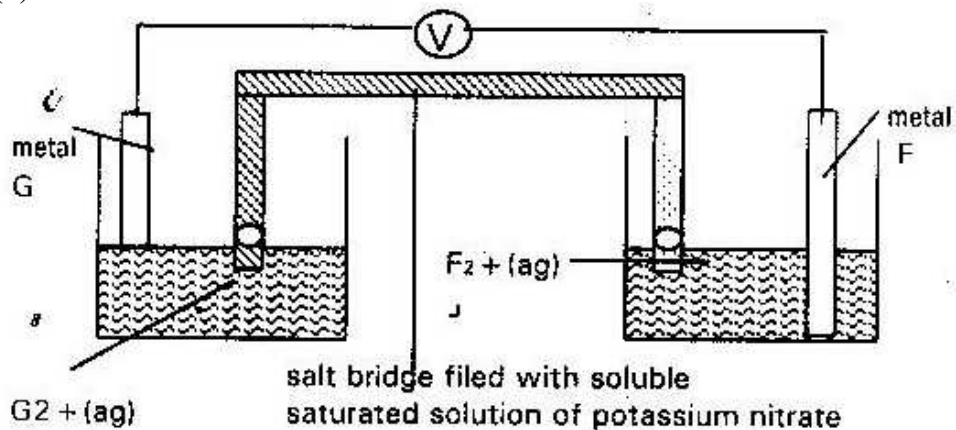

- i. Write the equation for the reactions that occur at the electrode F and G
 - ii. On the diagram indicate with an arrow the direction in which electrons would flow
 - iii. What is the function of the salt bridge? (1 mk)
- (c) An electric current was passed through concentrated solution of copper (II) chloride as shown in the diagram below.

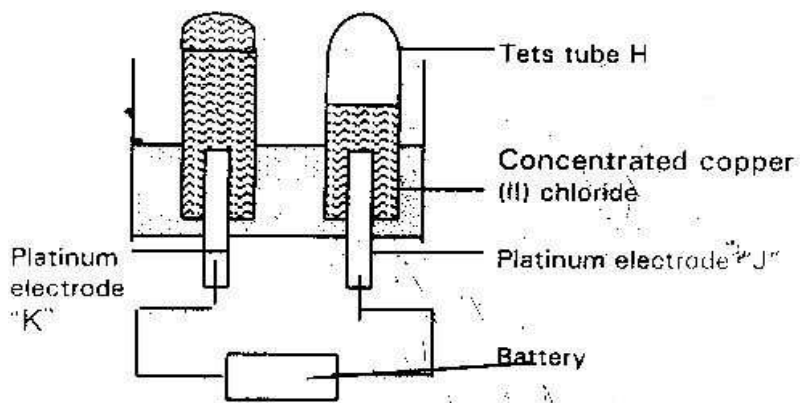

- i. Explain the observation that would be made on the electrolyte as the experiment progresses (2mks)
- ii. After some time test tube "H" was found to contain a mixture of two gases. Explain this observation (3mks)

iii. Which of the electrodes is the anode? Explain (2mks)

33.

The diagram below is a cross-section of a dry cell. Study it and answer the questions that follows

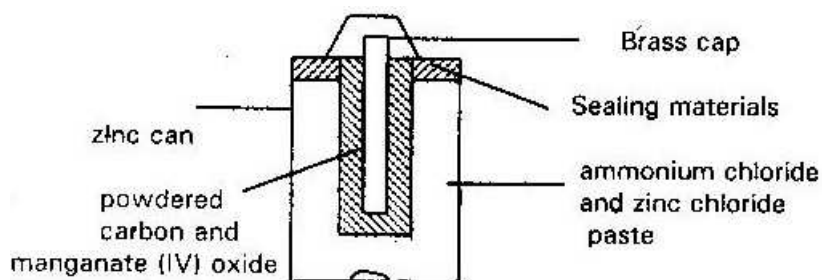

- (i) On the diagram, show with a (+ve) sign the +ve (positive terminal) (1 mk)
- (ii) Write the equation for the reaction in which electrons are produced (1 mk)
- (iii) The zinc can is lined with ammonium chloride and zinc chloride paste.

What would happen if the mixture was to become dry? Give a reason

(2 mks)

- (iv) Give one advantage and one disadvantage of dry cell (2 mks)

- (b) The setup up below was used to electrolyze molten lead (ii) Iodide

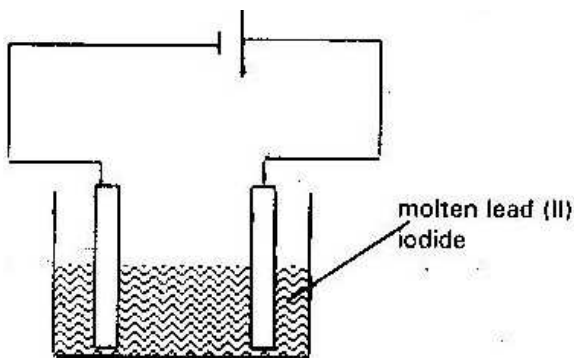

- i. State the observation that was made at the anode during the electrolysis.
Give a reason for your answer.
- ii. A current of 0.5A was passed for two hours. Calculate the mass of lead that was deposited (Pb= 207) (1 faraday = 96500c) (3mks)
- 34.
- (a) Brine usually contains soluble calcium and magnesium salts. Explain how sodium carbonate is used to purify brine (2mks)

(b) The diagram below represents a diagram cell used to electrolyte pure brim

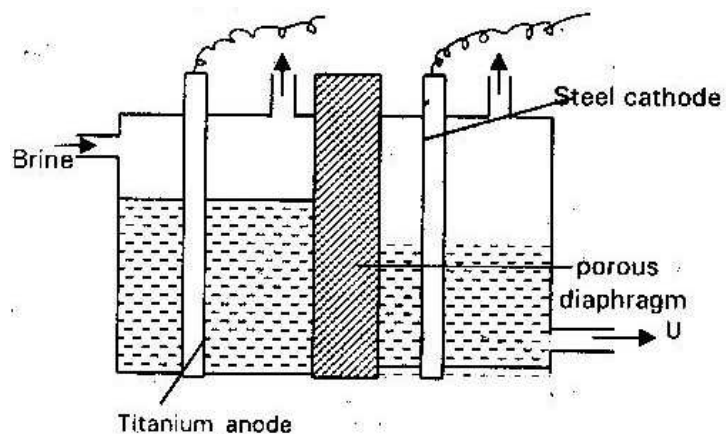

i. Write the equations for the reactions that take place at (2mks)

I. Cathode

II. Anode

ii. Name

I. Products U: (1 mk)

II. Another material that can be used instead of titanium (1 mk)

III. The impurity present in the product U (1 mk)

iii. State two functions of the porous diaphragm (2mks)

(c) Give one industrial use of the product "U" (1 mk)

35.

- (a) The equations below shows the standard reduction potential for four half cell. Study it and answer the questions that follows. Letters are not actual symbols of the element.

	E° Volts
$F_2(aq) + 2e^- \rightarrow 2F^-(av)$	+ 0.54
$G^{2+} + 2e \rightarrow G(s)$	-0.44
$H^{+2}(aq) + 2 e \rightarrow H(s)$	+ 0.34
$2J^+ + 2eJ^2(g) \rightarrow J2(g)$	0.00

- Identify the strongest reducing agent (1 mk)
- Write the equation for the reaction which takes place when solid "G" is added to a solution containing H^{2+} (ions) (2mks)
- Calculate the E° value for the reaction in (ii) above (1 mk)

- (b) The diagram below shows the apparatus used to electrolyze acidified water to obtain hydrogen and oxygen gases. Study it and answer the questions that follows?

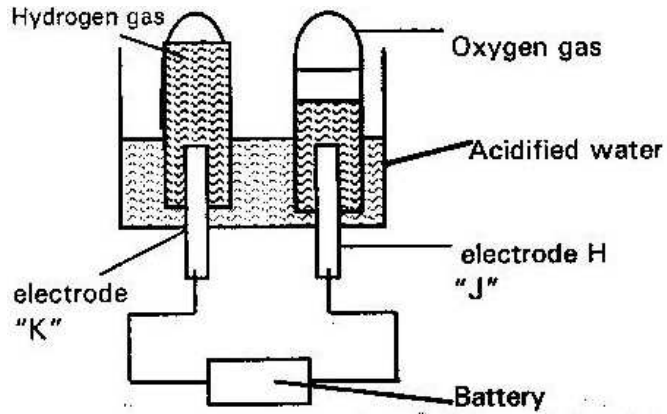

- i. Identify the electrode at which oxidation takes place (1 mk)
 - ii. Give a reason why it is necessary to acidify the water (1 mk)
 - iii. Explain why hydrochloric acid is not used to acidify the water (2mks)
- (c) During electrolysis of aqueous copper (II) sulphate 144750 columbus of electricity were used. Calculate the mass of copper metal that was obtained (CU= 64) (1 Faraday = 96500 Columbus) (3mks)

36.

- (a) Below is a simplified diagram of the down's cell used for the manufacture of sodium. Study it and answer the questions that follows.

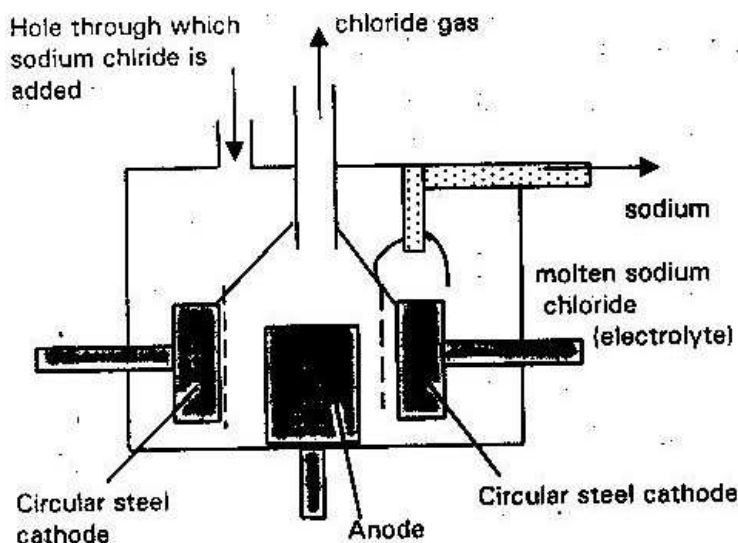

- i. What material is the anode made of? Give a reason (2mks)
 - ii. What precaution is taken to prevent chlorine and sodium from re-combining? (1 mk)
 - iii. Write an ionic equation for the reaction in which chlorine gas is formed (1 mk)
- (b) In the down's cell (Used for manufacture of sodium) a certain salt is added to lower the melting point of sodium chloride from about 800°C to 600°C
- i. Name the salt that is added
 - ii. State why is necessary to lower the temperature (1 mk)
- (c) Explain why aqueous sodium chloride is not suitable as an electrolyte for the manufacture of sodium in the down's cell- process (2mks)

- (d) Sodium metal reacts with air to form two oxides. Give the formula of the two oxides (2mks)
- (e) State two uses of sodium metal (2mks)

37.

- (a) What is an electrolyte (1 mk)
- (b) State how the following substances conduct electricity
- (i) Molten calcium chloride
 - (ii) Graphite
- (c) The diagram below shows a set up that was used to electrolyze aqueous magnesium sulphate

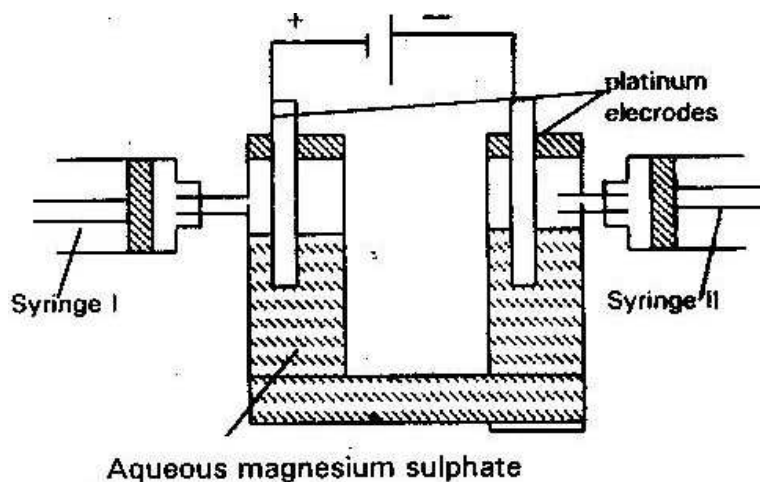

- (i) On the diagram above, using an arrow, show the direction of the flow of electrons (1 mk)
- (ii) Identify the syringe which hydrogen gas would be collected. Explain (1 mk)
- (d) Explain why the concentration of magnesium sulphate was found to have increased at the end of the experiment. (2mks)
- (e) During electrolysis a current of 0.72A was passed through the electrolyte for 15 minutes. Calculate the volume of gas produced at the anode. I Faraday = 96500 Columbus. Molar gas volume is 24000 at room temperature (4mks)

38.

The diagram below represents a set up that can be used to electrolyze aqueous copper (II) sulphate

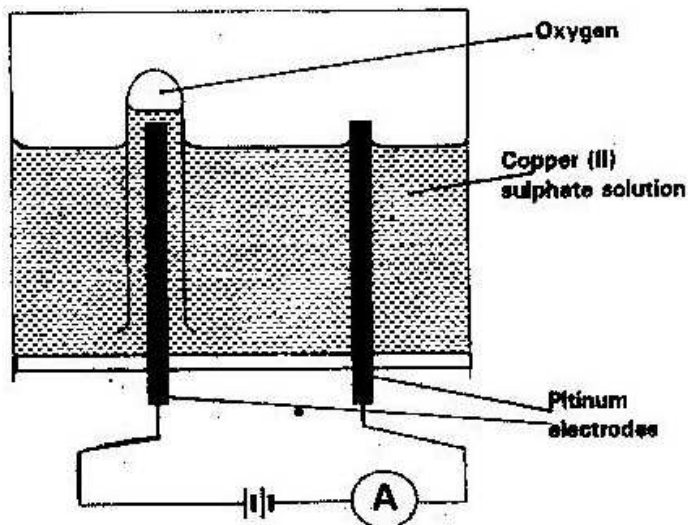

- (a) (i) Describe how oxygen gas is produced during the electrolysis
(2mks)
- (ii) Explain why copper electrodes are not suitable for this electrolysis
(2mks)
- (b) Impure copper is purified by an electrolytic process
- (i) Name one ore from which copper is obtained (1 mk)
- (ii) Write the equation for the reaction that occurs at the cathode during the purification of copper (1 mk)
- (iii) In an experiment to electroplate a copper spoon with silver, a current of 0.5A was passed for 18 minutes. Calculate the amount

of silver deposited on the spoon. (1F = 96500 coulombs, Ag) =
108)

(iv) Give two reasons why some metals are electroplated (2mks)

39. The following tables give the standard electrode potential for a number of half reactions.

	E ⁻ volts
$\text{Mg}^{2+}(\text{aq}) + 2\text{e} \rightarrow \text{Mg}(\text{s})$	-2.3
$\text{Mn}^{2+}(\text{aq}) + 2\text{e} \rightarrow \text{Mn}(\text{s})$	-1.18
$\text{Cd}^{2+}(\text{aq}) + 2\text{e} \rightarrow \text{Cd}$	-0.402
$2\text{H}^{+}(\text{aq}) + 2\text{e} \rightarrow \text{H}_2$	0.00
$\text{Ag}^{+}(\text{aq}) + \text{e} \rightarrow \text{Ag}(\text{s})$	+0.799
$\text{Ce}^{+4} + \text{E} \rightarrow \text{Ce}^{3+}$	+1.61

- (a) Which one of the substance is the strongest oxidizing agent (1 mk)
- (b) Which one if the substance is the strongest reducing agent (1 mk)
- (c) Select one of the substances from the table that could be used to oxidize silver ions and write the equation for the reaction. (2mks)

(d) Given the two half reactions

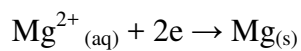
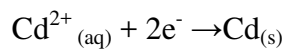

- (i) Write the cell representation made up of these two half reactions
(2mks)
- (ii) Write down the over all cell reaction for the cell formed by these
two half reactions (2mks)
- (iii) Calculate the E^{\ominus} value of this cell (2mks)

40. The diagram below shows a setup used to pass to electric current on molten lead

(ii) bromide

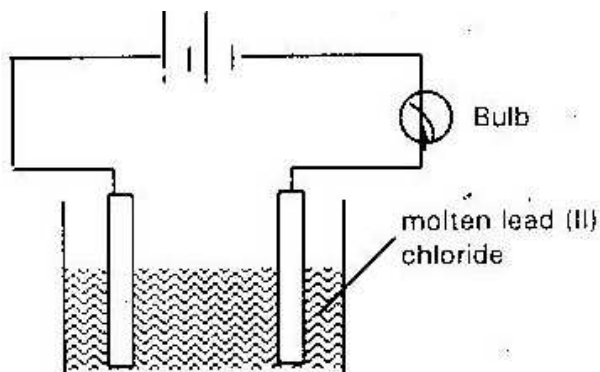

- (a) (i) What does the bulb show before the solid lead bromide is heated? (1 mk)
- (ii) Give a reason for your answer (1 mk)
- (b) Why was lead (ii) bromide in the molten state? (1 mk)
- (c) What observation is made at the cathode and anode respectively (2mks)
- (d) Write equations for the reactions at both electrodes (2mk)
41. (i) If the same arrangement was used to electrolyze aqueous potassium iodide. Iodine vapor would be collected at the anode and hydrogen gas at the cathode instead of potassium. Explain why (2mks)
- (ii) In an experiment chromium (iii) chloride is electrolyzed using the chromium electrodes. A current of 0.2A flows for 5788 seconds. The increase in mass of the electrode is 0.208g. Calculate the charge on the electrons. (Cr = 52) / Faraday = 96500C (3mks)
42. Consider the cell
- $$\text{Mn(s)} / \text{Mn}^{2+}(\text{aq}) // \text{Cd}^{2+}(\text{aq}) / \text{Cd(s)}$$
- E^\ominus for the manganese electrode is -0.40v calculate the e.m.f of the cell (1 mk)
43. Write cell reaction for the following electrochemical
- $$\text{Zn(s)} / \text{Zn}^{2+} // \text{Fe}^{3+}(\text{aq}) / \text{Fe/pt} \quad (2 \text{ mks})$$
44. Given the following standard electrode potential, $E^\ominus = -0.76\text{V}$
- $$\text{Zn}^{2+}(\text{aq}) + 2\text{e}^- \rightarrow \text{Zn(s)} \quad E^\ominus = 0.76\text{v}$$
- $$\text{Cl}_2(\text{g}) + 2\text{e}^- \rightarrow 2\text{Cl}^-(\text{aq}) \quad E^\ominus = +1.36\text{V}$$
- Calculate the EQ value for the cell (1 mk)

45. Two incomplete half cells are given below

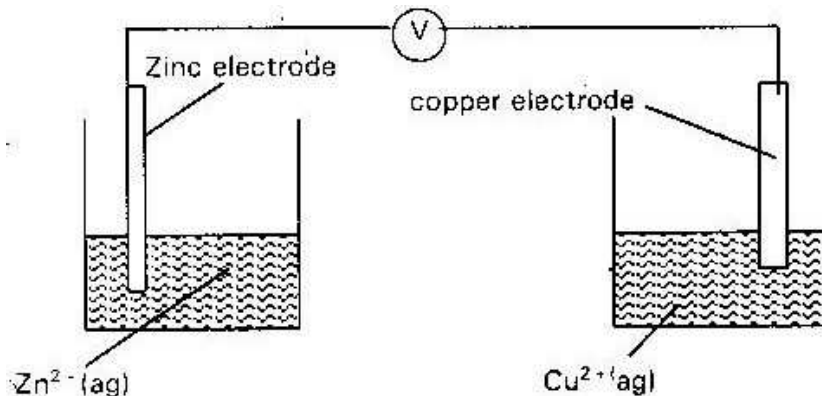

- Complete the diagram to show how the two half cells are connected to give an electrochemical cell. (2mks)
- Using arrows show the direction of the electron flow (1 mk)
- Indicate the direction of current flow
- Write the equation for the half cell/ reaction taking place at the electrodes (2mks)
- Write the overall cell reaction
- How many moles of electrons are transferred?
- Calculate the electronic charge transferred during reaction ($F= 96,500$ coulombs) (1 mk)

46. Magnesium reacts rapidly with copper (II) ions as follows

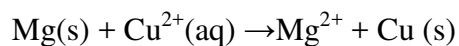

Give the half reaction for this reaction (1 mk)

47. (a) Explain the changes that takes place in solution and at the electrodes in the electrolysis of
- (i) Aqueous Sodium sulphate with invert electrodes (2mks)
 - (ii) Concentrated Sodium Chloride with carbon anode and mercury cathode (2mks)
- (b) Two electrolytic cells for solutions in a (i) and (ii) respectively were connected in series. A current of 1.5 A was passed for 600 seconds. The first cell contained aqueous copper (II) sulphate and had copper electrodes. The anode showed a loss in mass of 0.296 g but there was no change in the appearance of the electrolyte. The sodium chloride with little sodium hydroxide had copper electrodes and a reddish brown precipitate formed.
- (i) Why was there no change in the appearance of the electrolyte in the first cell
 - (ii) Why was a small amount of sodium hydroxide added to aqueous sodium chloride in the second cell?
 - (iii) Name the reddish- brown precipitate formed (1 mk)
 - (iv) Write an ionic equation for the formation of substance in (iii)
 - (v) Calculate the value of Faraday constant (1 mk)

48. Given that the standard electrode potential E° are

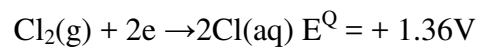
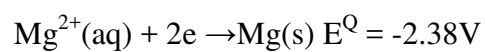

Find the e.m.f of the cell

TOPIC 4

METALS

1.

When magnesium metal is burnt in air it reacts with both oxygen and Nitrogen gas giving a white ash like substance. Write two equations for the two reactions that takes place.

2.

When excess Carbon (II) Oxide is passed over lead oxide in a combustion tube, lead (II) oxide is reduced.

- (a) Write an equation for the reaction which took place (1 mk)
- (b) What observations was made in the combustion tube when the reaction was complete (1 mk)
- (c) Name another gas which would be used to reduce lead (II) oxide (1 mk)

3.

When the oxide of element “H” was heated with powdered carbon, the mixture glowed and carbon (IV) oxide gas was formed. When the experiment was repeated using oxide of “J” there was no apparent reaction

- (a) Suggest one method that can be used to extract element J from its oxide (1 mk)
- (b) Arrange element H, J and carbon in the order of their decreasing reactivity

(1 mk)

4.

Study the flow chart below and answer the question that follows

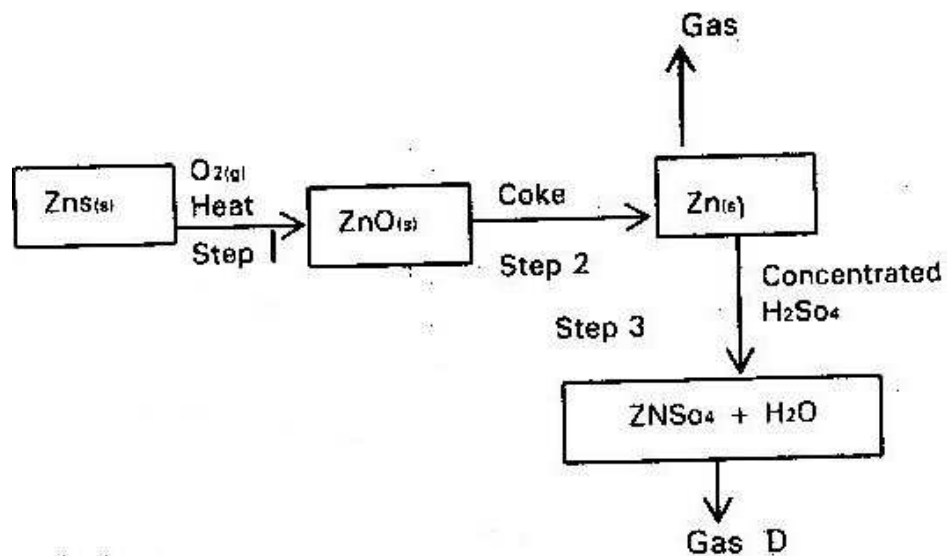

(a) State the conditions necessary for the reaction in step 2 to occur (1 mk)

(b) Name

(i) Gas P (1 mk)

(ii) One use of Zinc (1 mk)

5.

The set up below was used to obtain a sample of iron

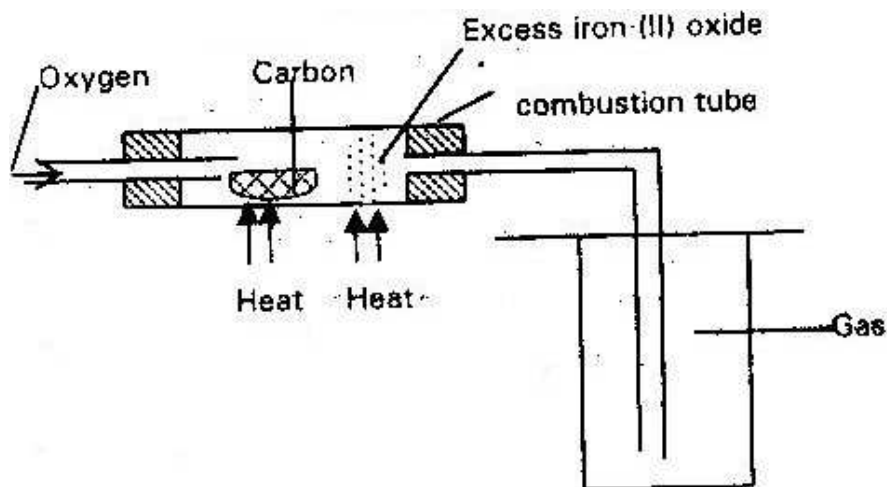

Write two equations for the reactions which occur in the combustion tube

(2 mks)

6.

Dry carbon (II) oxide gas react with heated lead (II) oxide as shown in the equation below

- Name the process undergone by the lead (II) Oxide (2 mks)
- Give a reason for your answer (a) above
- Name another gas that can be used to perform the same function as carbon gas in the above reaction (1 mk)

7.

In the industrial extraction of lead metal, the ore is first roasted in a furnace. The solid mixture obtained is then fed into another furnace together with coke limestone and scrape iron. State the functions of each of the following in this process.

- (a) Coke (1 mk)
- (b) Scrape iron (1 mk)
- (c) Limestone (1 mk)

8.

Study the flowchart and answer the questions that follows

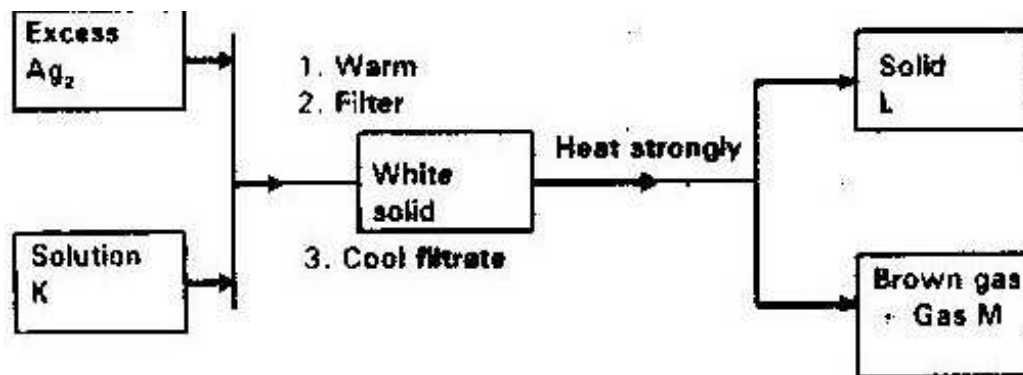

Identify

- (a) Solution K
- (b) Solid
- (c) Gas M

9.

The flow chart below shows steps used in the extraction of zinc from one of its

Ores.

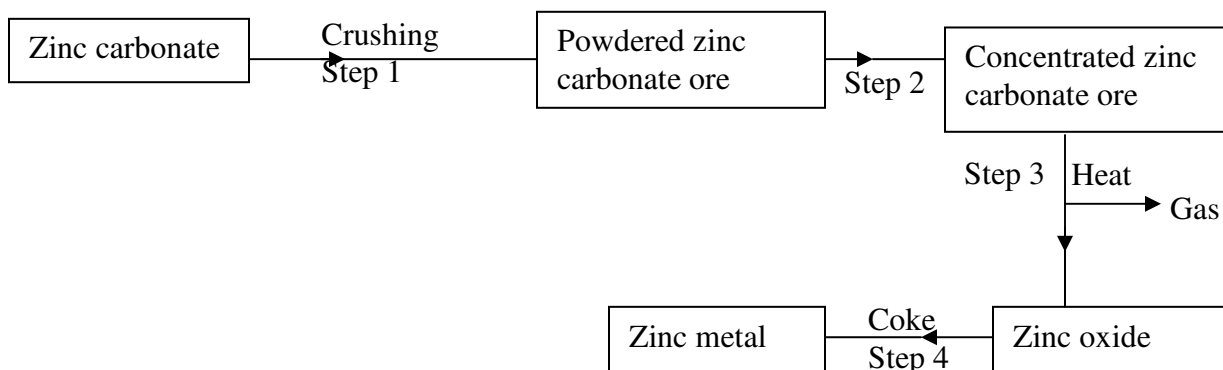

- (a) Name the process that is used in step 2 to concentrate the ore. (1 mk)
- (b) Write an equation for the reaction which takes place in step 3 (1 mk)
- (c) Name one use of zinc other than galvanizing (1 mk)

10.

During the extraction of aluminium from its ores; the ore is first purified to obtain alumina. The flow chart below shows the stages in the extraction of aluminium

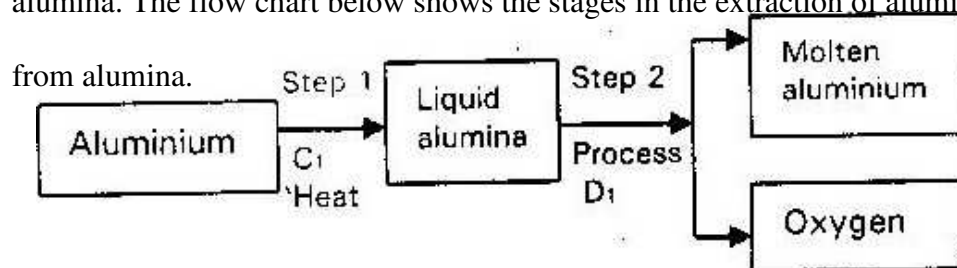

- (a) Name
- (i) Substance C_1 (1 mk)
- (ii) Process D_1 (1 mk)
- (b) Give two reasons why aluminium is used extensively in making of cooking pans (1 mk)

11.

The flow chart below outlines some of the process involved in extraction of copper from pyrites. Study it and answer the questions that follows

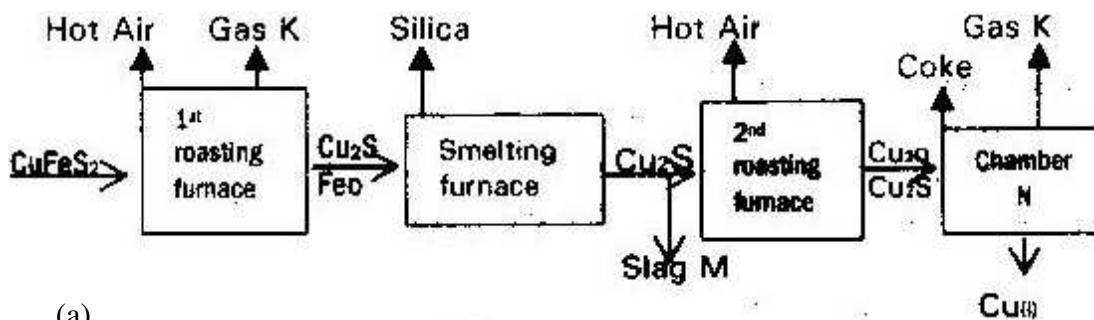

- (a)
- (i) Name gas “k”
- (ii) Write an equation for the reaction that take place in the 1st roasting furnace (1 mk)
- (iii) Write the formula of the cations present in the slag “M”
- (iv) Identify gas “P”
- (v) What name is given to the reaction that take place in chamber N. Give a reason for your answer?

- (b) The copper obtained “M” is not pure. Draw a labeled diagram to show the set up you would use to refine the copper by electrolysis. (2mks)
- (c) Given that the mass of copper obtained from the above extraction was 210 kg. Determine percentage purity of the ore (Copper pyrite) if 810 kg of it was fed to the 1st roasting furnace (4mks)
(Cu= 63.5) (Fe = 56) (S= 32)
- (d) Give two effects that this process could have on the environment (2mks)

12.

The flow chart below illustrates the industrial extraction of lead metal. Study it and answer the questions that follows

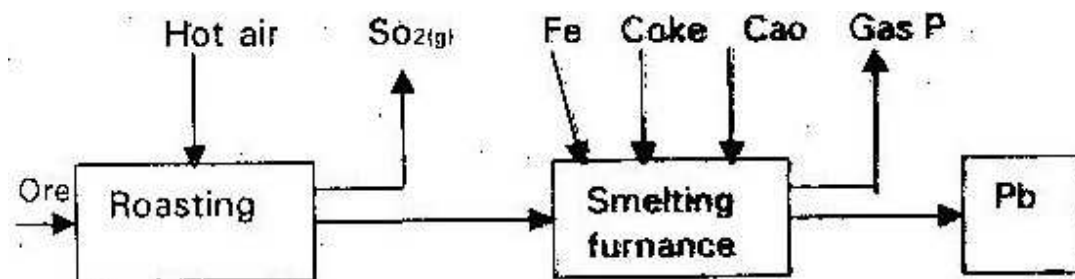

- (a) (i) Name the ore that is commonly – used in this process (1 mk)
- (ii) Explain what take place in the roasting furnace (1 mk)
- (iii) Identify gas “p” (1 mk)

- (iv) Write the equation for the main reaction that takes place in the smelting furnace (1 mk)
- (v) Give two environmental hazards likely to be associated with extraction of lead
- (vi) What is the purpose of adding iron in the smelting furnace? (1 mk)
- (b) Explain why hard water flowing in lead pipes may be safer for drinking them soft water flowing in the same pipes (3mks)
- (c) State one use of lead other than making lead pipes (1 mk)

13.

The raw material for extraction of aluminum is bauxite.

- (a) Name the method that is used to extract aluminium from bauxite (1 mk)
- (b) Write the chemical formula for the major components of bauxite (1 mk)
- (c) (i) Name the major impurities in bauxite (3mks)
- (ii) Explain how the impurities in bauxite are removed (3mks)
- (d) Cryolite is used in the extraction of aluminium from bauxite. State its function (1 mk)
- (e) Describe how carbon (IV) oxide is formed during the extraction of aluminium (2mks)
- (f) Aluminum is a reactive metal yet utensils made from aluminium do not corrode easily. Explain this observation

14.

The extraction of iron from its ore takes place in the blast furnace. Below is a simplified diagram of a blast furnace. Study it and answer the questions that follow.

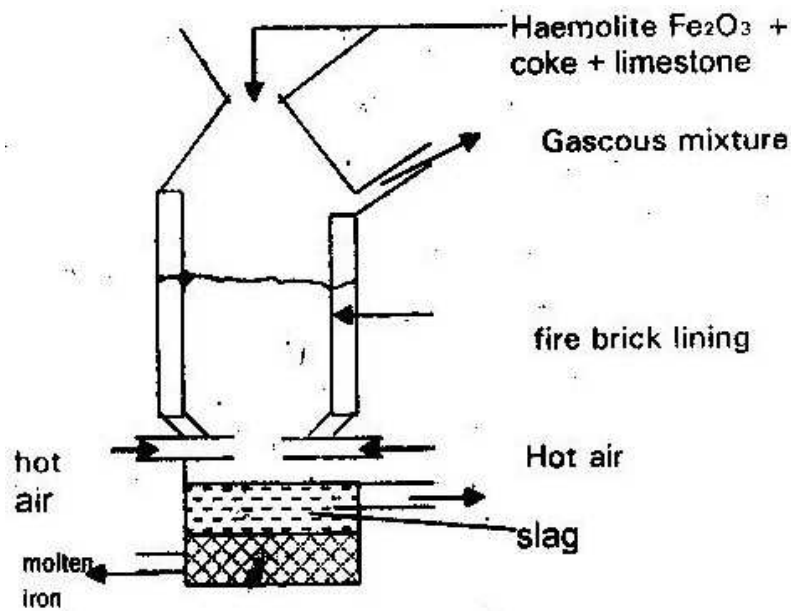

- (a) (i) One of the substances in the slag (1 mk)
- (ii) Another iron ore material used in the blast furnace (1 mk)
- (One gas which is recycled) (1 mk)
- (b) Describe the process which leads to the formation of iron in the blast furnace
- (c) State the purpose of limestone in the blast furnace (1 mk)
- (d) Give a reason why the melting point of iron obtained from the blast furnace is 1200° while that of pure iron is 1535°C (1 mk)

(e) State two uses of steel (2mks)

15. The flow chart below shows a sequence of chemical reactions starting with copper. Study it and answer the questions that follow

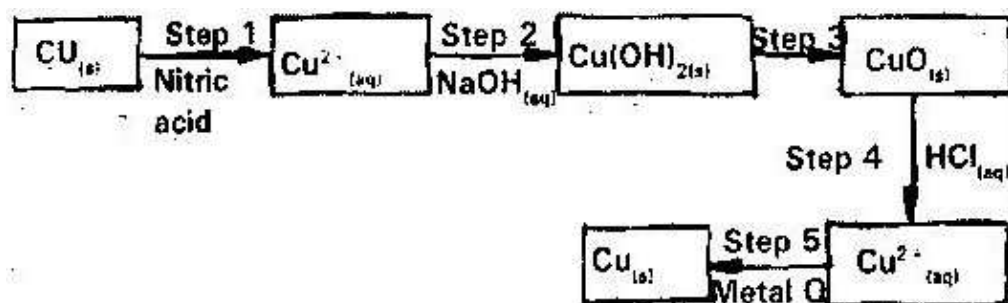

- (a) In step 1, excess 3M nitric acid was added to 0.5 of copper powder
- State two observations which were made when the reaction was in progress (2mks)
 - Explain why dilute hydrochloric acid cannot be used in step 1 (1 mk)
 - I. Write the equation for the reaction that took place in step 1 (1mk)
II. Calculate the volume of 3M nitric acid that was needed to react completely with 0.5g of copper powder (Cu= 63.5) (3mks)
- (b) Give names if the type of reactions that took place in steps 4 and 5 (1 mk)
- (c) Apart from the good conductivity of electricity, state two other properties that make it possible for copper to be extensively used in the electrical industry (2mks)

16. Study the flow chart below and answer the questions that follow

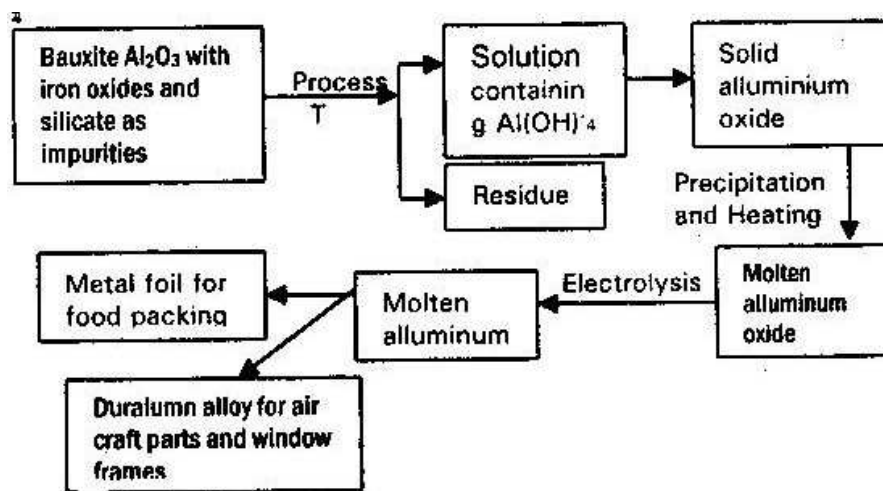

- (i) Suggest a purpose for the industry process represented by the flow chart
(1 mk)
- (ii) Explain how process T is carried out
(2mks)
- (iii) Explain why it is necessary to heat aluminium oxide before electrolysis is carried out
(1mk)
- (iv) Suggest a reason to why carbon is not used for reduction of aluminium Oxide
(1 mk)
- (v) What properties of aluminum and the alloy make them suitable for use indicated?
(2mks)

17. The flow chart illustrates the extraction of zinc and preparation of Zinc (II) sulphate crystals. Study it and answer the questions that follow

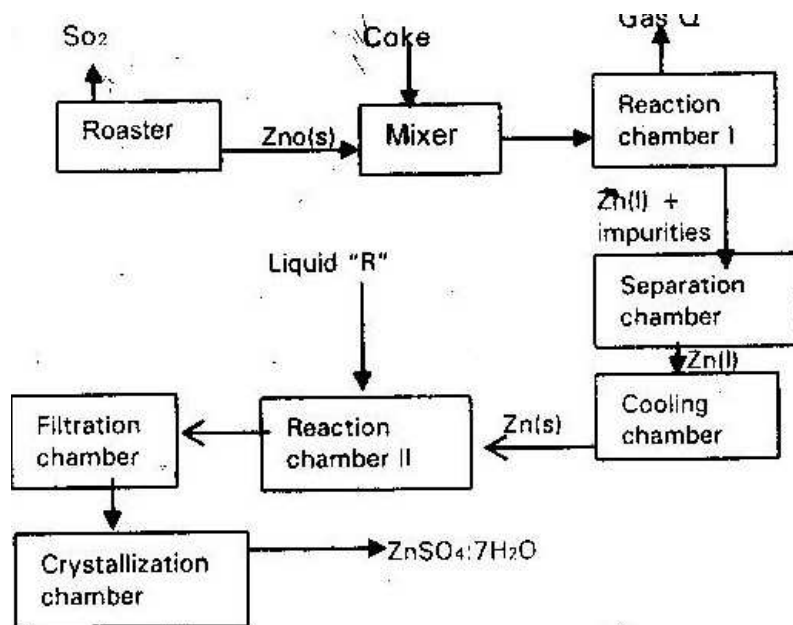

- (a)
- (i) Name
- I. Gas Q (1 mk)
- II. Liquid R (1 mk)
- (ii) Write an equation for the reaction that takes place in
- Chamber I (1 mk)
 - The Roster (1 mk)
 - Chamber II (1 mk)
- (iii) Given that the zinc sulphide ore contain 45% of Zinc sulphate by mass calculate

- I. The mass in grains of Zinc sulphide that would be obtained from 250 kg of the ore (1 mk)
- II. The volume of sulphur (IV) oxide (SO₂) that would be obtained from the mass of zinc (1 mk)
- III. Sulphide obtained in 1 above at room temperature and pressure (Zn = 65.4) (S = 32.0) molar gas volume = 24 dm³
- (b) In such an experiment sulphur (IV) Oxide may keep escaping to the atmosphere. Explain how this could affect the environment. (2mks)
- (c) Suggest one other man manufacturing plant that could be set up near Zinc extraction plant. Give a reason for your answer
18. Iron Pyrites was heated in air to give Iron (III) oxide and a gas X: This is also when a yellow powder is burned in limited amount of air.
- (i) Identify the yellow powder (1 mk)
- (ii) Identify gas X (1 mk)
- (iii) Write a chemical equation to show the reaction between gas X and aqueous Sodium Hydroxide (1 mk)
19. Hydrogen was passed over heated iron (III) oxide, but no reaction occurred. Iron (III) oxide was heated with carbon, Iron was formed and after separation it was dissolved in dilute sulphuric acid. A gas “Y” was evolved.
- (a) (i) Is the reaction between hydrogen and iron (III) oxide physical or

- chemical explain (2mks)
- (ii) Explain why carbon reacted with iron (III) oxide while hydrogen did not (2mks)
- (iii) Identify gas Y (1 mk)
- (b) Iron window frames corrode quickly unless carefully protected but aluminum window frames are resistant to corrosion
- (i) Give the chemical name of the substance formed when iron rust
- (ii) Why does aluminium items does not corrode as quickly as iron (1 mk)
- (iii) Explain why galvanized iron is resistant to corrosion even when the protective layer of zinc is broken (2mks)

20. Study the table below of oxides and sulphides formed by different elements and answer the questions that follow.

Elements	Oxides	Sulphides
Copper	CUO, CU ₂ O	CuS, Cu ₂ S
Hydrogen	H ₂ O	H ₂ S

With reference to the periodic table, what is the relationship between oxygen and sulphur (1 mk)

21. Two metals "A" and "B" have close packed and body centered cubic respectively. Which metal has the highest melting point (1 mk)
22. Aluminium metal is a good conductor and is used for over head cables. State any two other properties that make aluminium suitable for this use.

23. The table below shows the properties of substances K, L, M and N

Substance	Reaction with oxygen	Melting point	Conductivity	
			Solid	Molten
K	Unreactive	High	Good	Good
L	Reactive	Low	Poor	Poor
M	Unreactive	High	Good	Good
N	Unreactive	Low	Good	Good

Select the substance which is likely to be

- (a) Copper metal (1 mk)
- (b) Magnesium chloride
24. (a) An ore is suspected to containing mainly iron. Describe a method that can be used to confirm the presence of iron in the ore (4mks)
- (b) Excess Carbon (II) oxide was passed over a heated sample of an oxide of iron as shown in the diagram below. Study the diagram and the data below it to answer the question that follows

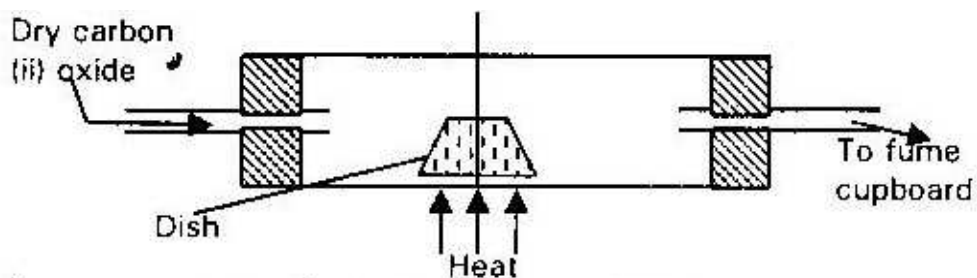

Mass of empty dish 10.98g

Mass of empty dish + oxide of iron 13.30g

Mass of empty dish + residue 12.66g

- (i) Determine the formula of the oxide of iron. Relative mass of oxide of iron is 232, Fe= 56, O = 16 (2mks)
- (ii) Write equation for the reaction which took place in the dish (1 mk)
- (c) Corrosion is a destructive process in which iron is converted into hydrated (III) Oxide. State
- (i) Two conditions necessary for rusting to occur (1 mk)
- (ii) One method used to protect iron from rusting (1 mk)
- (d) Explain why it is not advisable to wash vehicles using sea water (2mks)

25. Lithium metal react with water less vigorously than sodium metal explain (1 mk)

TOPIC 5

ORGANIC CHEMISTRY II

1. A compound where structure is shown below is found in detergent

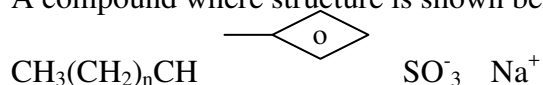

With reference to the structure, explain how the detergent removes grease during washing (2mks)

- 2.

Complete the table below by inserting the missing information in the spaces

provided (4mks)

Name of polymer	Name of monomer	Use of polymer
Polystyrene		
	Vinyl chloride	

- 3.

The structure below represent five cleaning agents

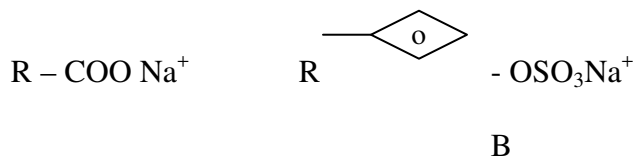

Which cleansing agent would be more suitable for washing in water containing magnesium sulphate? Explain (2mks)

- 4.

- (a) Draw the structure of ethanol and propanoic acid (2mks)
- (b) Give the name of the organic compound formed when ethanol and propanoic acid react in presence of concentrated sulphuric acid (1 mk)

5.

The structure below represent a portion of a polymer

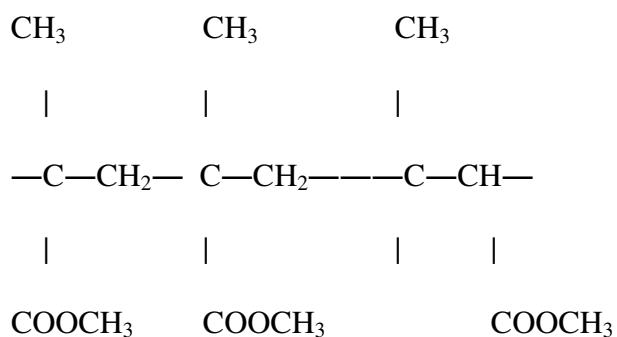

Give

- (a) The name of the polymer (1 mk)
- (b) On industrial use of the polymer (1 mk)

6.

An organic compound with the formula $\text{C}_4\text{H}_{10}\text{O}$ react with potassium metal to give hydrogen gas and a white solid.

- (a) Write the structure formula of the compound (1 mk)
- (b) To which homologous series does the compound belong (1 mk)
- (c) Write the equation for the reaction between the compound and potassium metal (1 mk)

7.

Study the information in the table below and answer questions that follow

Alcohol's	Heat of combustion KJ/M
Methanol	715
Ethanol	1371
Prepanal	2010
Bufanal	2673

Give a reason why the differences in heat of combustion between successive alcohol are close

8.

Study the below chart and answer the questions that follows

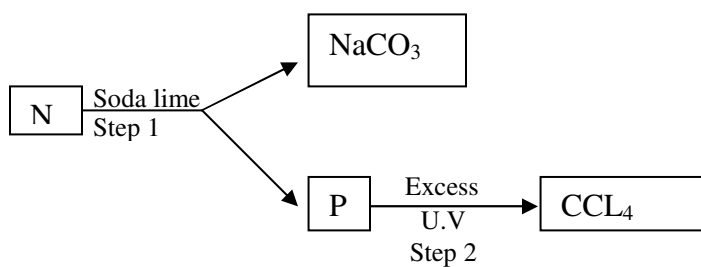

(a) Identify N and P (2mks)

(b) What name is given to the type of halogenation/ chlorinating reaction given in step 2 (1 mk)

9.

Name the process that takes place when crystals of Zinc Nitrate change into solution when exposed to air. (1 mk)

10. 2007: PP 1 Q. 23

The table below shows the relative molecular masses and the boiling points of pentane and propan -1 -ol

	Relative molecular mass	Boiling point ($^{\circ}$ C)
Pentane	72	36
Propan - 1-ol	60	97

Explain why the boiling point of propan -1 -ol is higher than that of pentane

(2mks)

11.

The table below gives the information of some carboxylic acids and then draw points

Acid	Boiling point ($^{\circ}\text{C}$)
HCOOH	101
CH ₃ COOH	118
CH ₃ CH ₂ COOH	141
CH ₃ CH ₂ CH ₂ CH ₂ COOH	187
CH ₃ CH ₂ CH ₂ CH ₂ CH ₂ COOH	205

(a)

(i) Give the name of the acid whose formula

CH₃CH₂CH₂CH₂COOH (1 mk)

(ii) What is the empirical formula of CH₃CH₂CH₂CH₂CH₂COOH (1 mk)

(iii) Plot the graph of boiling point against number of a ions of the carboxylic acids (3mks)

I. From the graph determine the boiling point of the acid

CH₃CH₂CH₂COOH (2mks)

(iv) Explain giving reasons the shape of the graph (2mks)

(b) Explain the observation which would be made if NaHCO₃ is added to an aqueous solution containing HCOOH (2mks)

- (c) Calculate the volume of 0.2M sodium hydroxide solution which would be required to react completely with a solution containing 3.0 g of CH_3COOH . (C= 12) (H= 1.0) (O= 16) (3mks)

12.

The formula given below represent a portion of a polymer

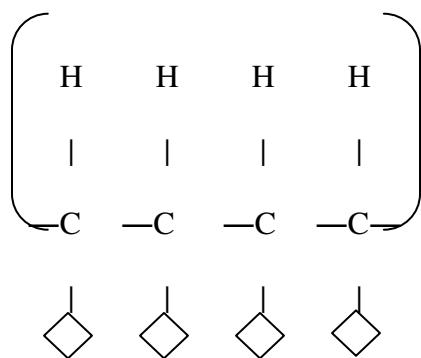

- (a) Give the name of the polymer (1 mk)
- (b) One disadvantage of the continued use of this polymer (1 mk)

13.

- (a) When organ compound “Y” is reacted with aqueous sodium – carbonate. It produces carbon (IV) oxide. “Y” reacts with propanol to form a sweet smelling compound “Z” whose formula is.

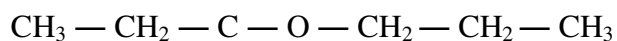
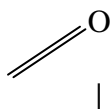

- (i) Name and draw the structural formula of compound “Y” (1 mk)
- (ii) What is the name of the group of compound to which “Z” belong (1 mk)
- (b) In an experiment, excess ethanol is warmed with acidified potassium dichromate for about 20 minutes. State and explain the observations that was made at the end of the experiment
- (c) The scheme below was used to prepare a cleansing agent. Study it and answer the questions that follow

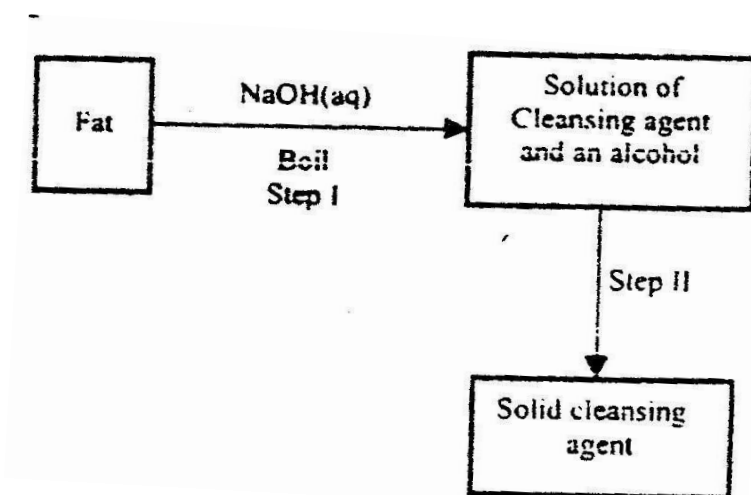

- (i) What name is given to the type of cleansing agent prepared by the method shown in the scheme (1 mk)
- (ii) Name one chemical substance in the scheme (1 mk)
- (iii) What is the purpose of adding the chemical substance named in C (ii) above? (1 mk)
- (iv) Name one other suitable substance that can be used in step 1 (1 mk)
- (v) Explain how an aqueous solution of the cleansing agent removed oil from utensils during washing (3mks)

14.

- (a) Write the formula of
- (i) Methanol (1 mk)
 - (ii) Methanoic acid (1 mk)
- (b) Write the equation for the reaction between methanoic acid and the aqueous sodium (1 mk)
- (c) (i) Name the product formed when methanol react with methanoic acid (1 mk)
- (ii) State one condition necessary for the reaction in (c) (i) above to take place (1 mk)
- (iii) Hydrogen gas reacts with ethene to form ethane. Calculate the volume of hydrogen gas required to convert 42g of ethene to ethane at S.T.P (C= 12) (H=1) Molar gas volume at STP = 22.4dm^3 (4mks)

15.

The flow chart below shows a series of reactions starting with ethanol. Study it

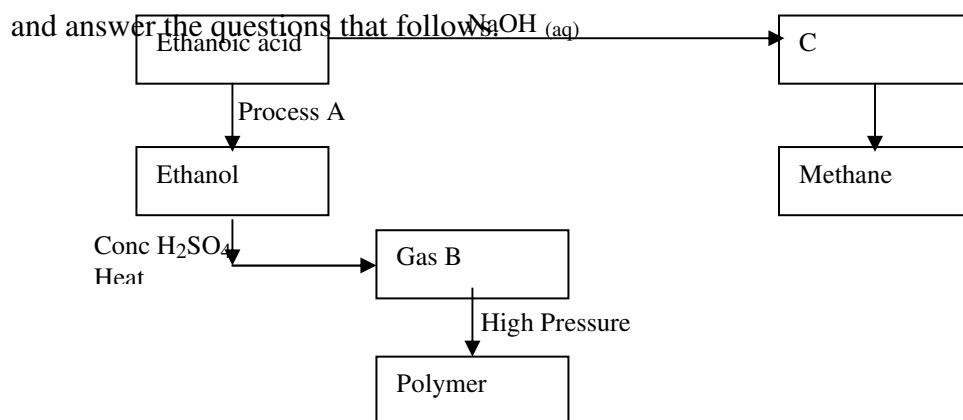

- (i) Name
- I. Process A (1 mk)
 - II. Substance "B" and "C" (1 mk)
- (ii) Write the equation for the combustion of ethanol (1 mk)
- (iii) Explain why it is necessary to use high pressure to change B into polymer (1 mk)
- (iv) State one use of methane (1 mk)

16.

- (a) The list below gives the formula of some organic compounds. Use it to answer the questions that follow.

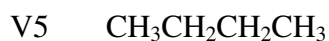
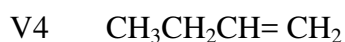
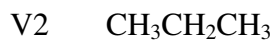

- (i) Select two compounds which
- I. Are not hydrocarbons (1mk)
- II. Belong to the same homologous series (1mk)
- (ii) Identify the compound that is likely to undergo polymerization.
Give a reason for your answer (2mks)
- (b) The structure below represents two cleansing agents
- $R-COO^-Na^+$
- $R-OSO_3^-Na^+$

In the table below give one advantage and one disadvantage using each of them

	Advantage	Disadvantage
$R-COO^-Na^+$		
$R-OSO_3^-Na^+$		

- (c) Under certain conditions, Ethanoic acid $C_2H_4O_2$ and ethanol reacts to form a sweet smelling compound
- (i) What is the general name of the compounds to which the sweet smelling compound belong (1 mk)
- (ii) Write the formula of the sweet smelling compound (1 mk)
- (iii) Give one use of ethanoic acid other than the formation of the sweet smelling compounds (1 mk)
- (iv) Write an equation between dilute Ethanoic acid and solid potassium carbonate (1 mk)
- (d) Fibres are either synthetic or natural. Give one

- (i) Example of natural fibre (1 mk)
- (ii) Advantages synthetic fibres have over natural fibres (1 mk)

17.

(a) Give the systematic names of the following compounds

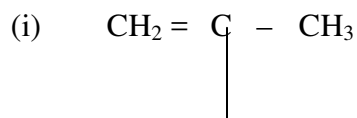

CH₃ (1 mk)



(b) State the observations made when propan-1-ol reacts with:

(i) Acidified potassium dichromate (VI) solution (1 mk)

(c) Ethanol obtained from glucose can be converted to ethane as shown below

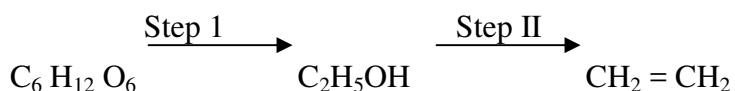

Name and describe the processes that take place in steps I and II (3mks)

(d) Compound A and B have the same molecular formula C₃H₆O₂. Compound A liberates carbon (IV) oxide on addition of aqueous sodium carbonate while compound B does not. Compound B has a sweet smell. Draw the possible structures of.

- Compound A (1 mk)

- Compound B (1 mk)

- (e) Give two reasons why the disposal of polymers such as polychloethane by burning pollutes the environment. (2mks)

18.

- (a) Alkanes, alkenes and alkynes can be obtained from crude oil. Draw the structures of the second member of the alkyne homologous series (1 mk)

(b) Study the flow chart below and answer the questions that follows

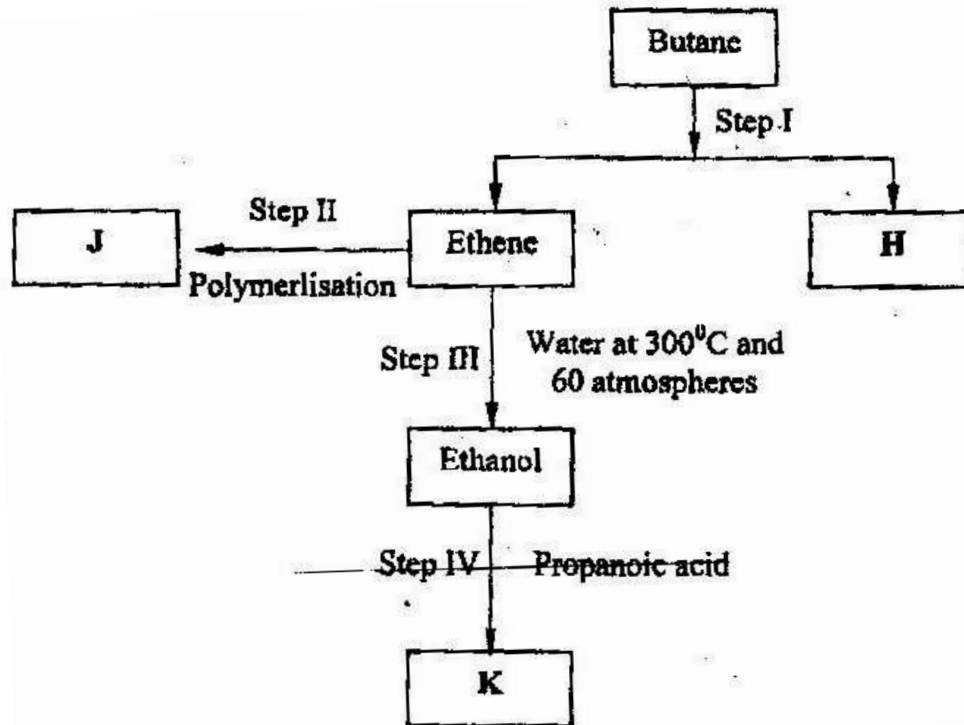

- (i) State the conditions for the reaction in step I to occur (1 mk)
- (ii) Identify substance H (1 mk)
- (iii) Give
- I. One disadvantage of the continued use of substances such as J (1 mk)
 - II. The name of the process that takes place in step III (1 mk)
 - III. The name and the formula of substance K. (2mks)
 Name.....
 Formula.....
- (iv) The relative molecular mass of J is 16,800 calculate the number of monomers that make up J (2mks)

(c) The table below gives the formula of four compounds L, M, N and P

Compound	Formula
L	C_2H_6O
M	C_3H_6
N	$C_3H_6O_2$
P	C_3H_8

Giving a reason in each case, select the letter which represents a compound that:

- (i) Decolourise bromine in the absence of UV light (2mks)
- (ii) Gives effervescence when reacted with aqueous sodium carbonate. (2mks)

19. The following is formula of monosaccharide (glucose)

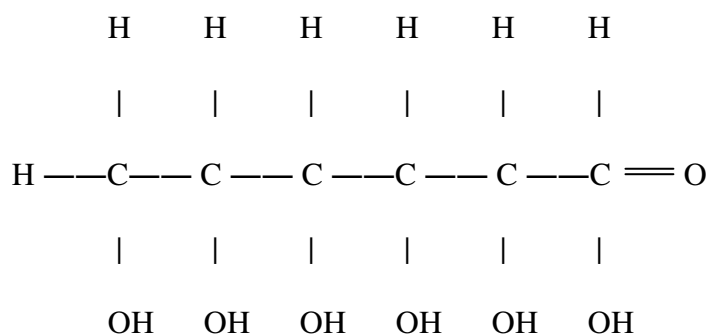

- (i) What is meant by monosaccharide (1 mk)
- (ii) How would glucose be converted into cellulose (2mks)

20. Consider the following

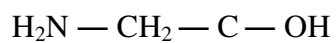

(ii)

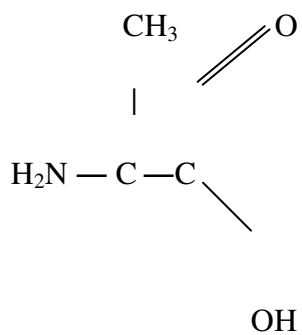

(iii)

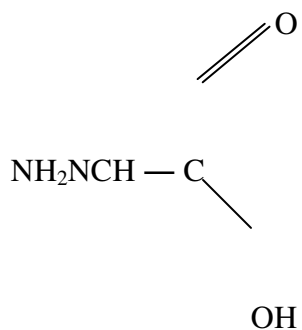

- (i) What is the name of this class of compounds (1 mk)
- (ii) What do ii and iii have in common? (2 mks)
- (iii) Give the conditions of the reaction and name the products formed when compound i react with ethanol.

21. 2.635g of chloro propanoic acid ($\text{ClCH}_2\text{CH}_2\text{COOH}$), were dissolved into 250 cm^3 of solution. 25 cm^3 of the acid required, 25 cm^3 of 0.1m potassium hydroxide solution for complete neutralization.
- (i) Write an equation for the reaction between potassium hydroxide and chloropropanoic acid. (1 mk)
- (ii) Calculate the number of moles of chloropropanoic acid per dm^3 (2mks)
- (iii) Calculate the number of moles of
- (i) Potassium hydroxide used (1 mk)
- (ii) Chloropropanoic acid that would react with the number of moles of potassium hydroxide in 1 above (2mks)

22. Below is a scheme of some reactions of ethanol. Study it and answer the questions that follow

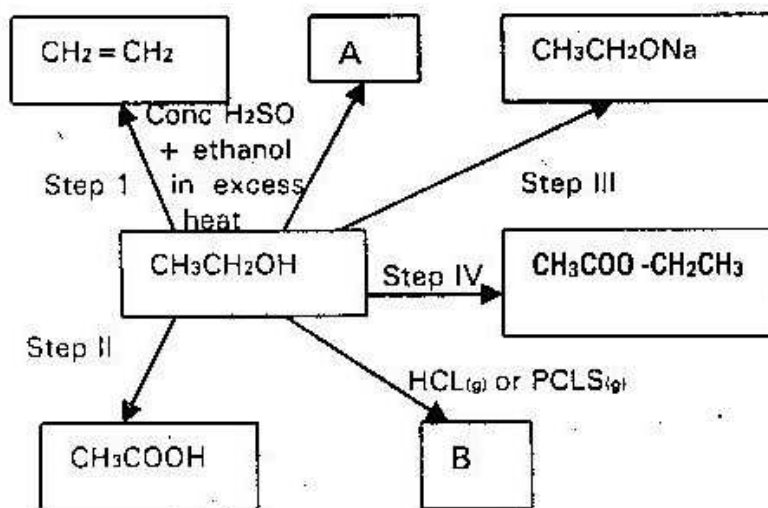

- (i) State the conditions and the reagents required in steps I, II, III and IV (4mks)
- (ii) Name the major products "A" and "B" (2mks)
23. A form (IV) student is interested in marking Terylene for his project. He needs your advice on how to go about it.
- (a) Explain to him what type of polymer is terylene. (2mks)
- (b) Given that terylene is synthesized from ethane -1, 2-diol $\text{CH}_2\text{CH}_2(\text{OH})_2$ benzene -1, 4-dicarboxylic acid $\text{CH}_2(\text{COOH})_2$
- (i) Draw the polymer unit of terylene consisting of two monomeric units. (2mks)
- (ii) Name the product eliminated (1 mk)
- (c) Give two
- (i) Properties of terylene (2mks)

- (ii) Uses of terylene
- (d) (i) Give two examples of natural polymer below. (2mks)
- (ii) What is vulcanization? (2mks)
- (e) (i) Draw the monomer of the polymer below (1 mk)

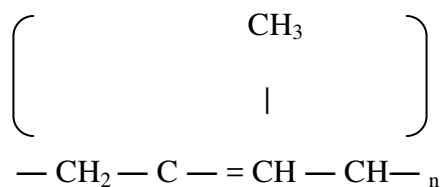

- (ii) Name the monomer (1mk)

24. Complete the following reaction

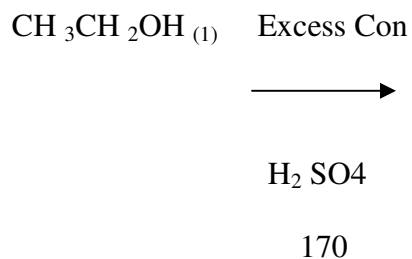

(1 mk)

25. Consider the following compounds

- (a) $\text{CH}_3\text{CH}_2\text{CH}_2\text{COOH}$
- (b) $\text{CH}_3\text{CH}_2\text{COOCH}_2\text{CH}_3$
- (c) $\text{HOOCCH}_2\text{CH}_2\text{COOH}$
- (d) $\text{CH}_3\text{CH}(\text{OH})\text{CH}_3$

Which of these compounds is

- (i) Diabasic acid
- (ii) An Ester

26. How would each of the following compounds be chemically distinguished

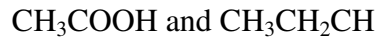

27. Name the reagents and state the condition of the reaction necessary to affect the changes given below



28. The formula below represents the active ingredients in a detergent and in a soap respectively.

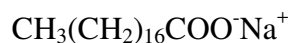
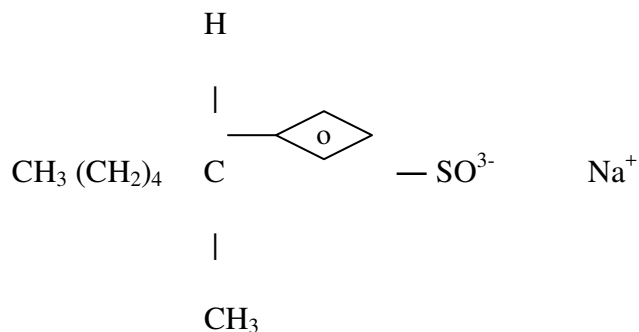

(a) What is a detergent? (1 mk)

(b) Give two advantages and two disadvantages of using detergents as cleansing agent (2mks)

(c) Explain briefly the mode of action of soap during cleansing (3mks)

- (d) Give a reason for adding polyphosphate to the detergents (1 mk)
- (e) Explain briefly how the soap given above may be manufactured (3mks)

TOPIC 6

RADIOACTIVITY

1.

Complete the following equation

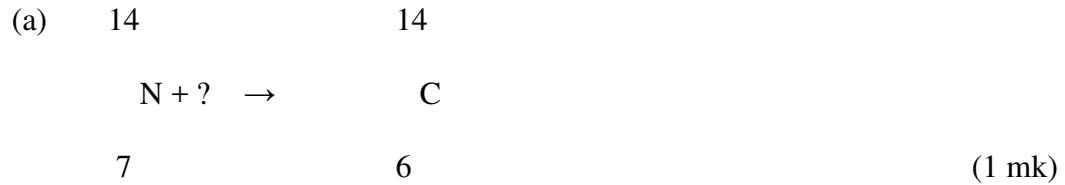

(b) Give one use of radioactive elements (1 mk)

2.

The table below gives the rate of decay for radioactive element Y

Number of days	Mass (g)
0	348
270	48

Calculate the half – life of the radioactive element “Y” (1 mk)

3.

233

100g of radioactive Pa was reduced to 12.5g after 81 days

91

(a) Determine the half life of “Pa”

233

- (b) Pa decay by beta emission, what is the mass number and atomic number of
 91 the element formed (1 mk)

4.

Complete the diagram below to show how α and β particles from radioactive can be distinguished from each other. Label your diagram clearly. (3 mks)

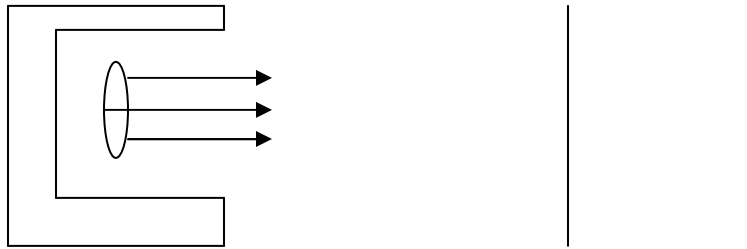

Source of radiation

Paper

Metal foil

5.

M grammes of radioactive isotope decayed to 5.0g in 80g. The half life of the isolate is 25 days

- (a) What is meant by half life (1 mk)
- (b) Calculate the initial mass “m” of radioactive isotope (2mks)

6.

234

An isotope of uranium ^{234}U , decay by emission of an alpha particle to thorium (Th)

94

(a) Write the equation for the nuclear reaction undergone by the isotope

(1 mk)

(b) Explain why it is not safe to store radioactive substance in conditions made from aluminum sheet

(1 mk)

7.

The graph below shows the mass of a radioactive isotope plotted against time

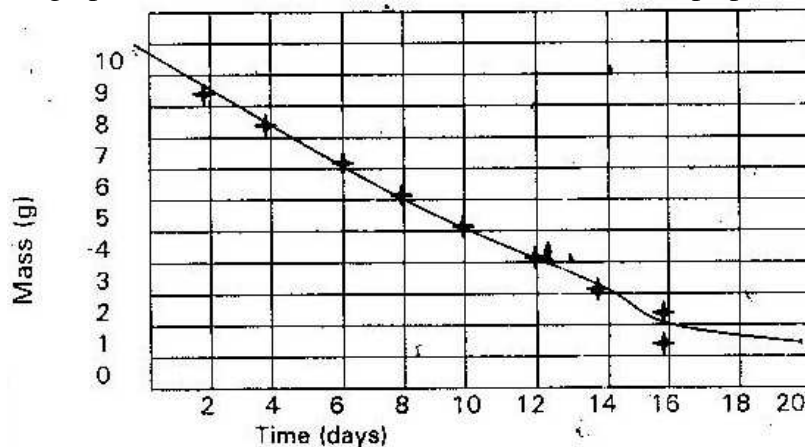

- (a) Using the graph determine, the half life of the isotope (1 mk)
- (c) Calculate the mass of the isotope present after 32 days (2mks)

8.

A radioactive isotope X_2 decay by emitting two alpha particles and one β particles to form ${}_{83}^{214}$

β^1

${}_{83}^{214}$

- (a) What is the atomic number of X_2 (1 mk)
- (b) After 112 days $\frac{1}{16}$ of mass of X_2 remained. Find the half life of X (2mks)

9.

Study the nuclear reactions given in the scheme below and answer the questions that follows

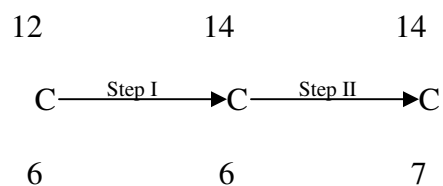

${}_{12}^{12}\text{C}$ ${}_{12}^{14}\text{C}$

- (a) ${}_{12}^{12}\text{C}$ and ${}_{12}^{14}\text{C}$ are isotopes. What is meant by the term isotopes?
- ${}_{6}^{12}\text{C}$ ${}_{6}^{14}\text{C}$
- (b) Write an equation for the nuclear reaction in step II (1 mk)

14

(c) Give one use of C

16

10.

The graph below represents a radio active decay series for isotope “H”, study it and answer the equations that follows

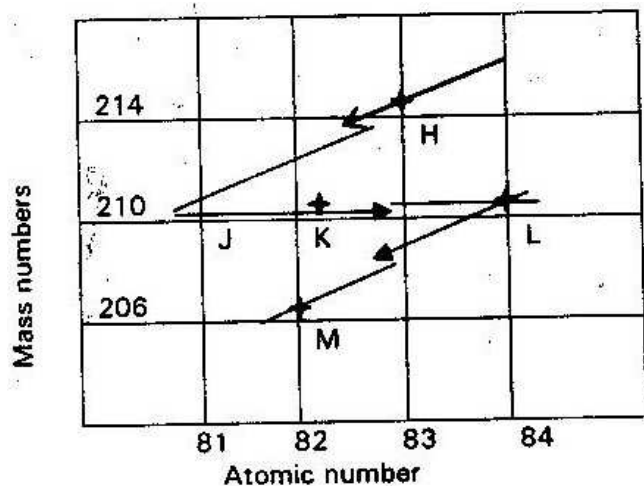

(a) Name the type of radiation emitted when isotope it changes to isotope “Y”

(1 mk)

(b) Write an equation for the nuclear reaction that occurs when “J” changes to isotope “K”

(1 mk)

(c) Identify a pair of isotope of an element in the decay series

(1 mk)

11.

100g of radioactive substance was reduced to 12.5 g within 15.6 years. Calculate the half life of the substance

(2mks)

12.

- (a) Complete the number equation below

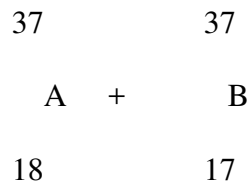

- (b) State one

- (i) Use of radioisotope in agriculture
(ii) Dangers associated with expose to human being to radioisotopes

(1 mk)

13.

- (a) Distinguish between nuclear fission and nuclear fusion
(b) Describe how solid wastes containing radioactive substances should be disposed of

(1 mk)

14.

- (a) A radioactive substance emits three different particles.

Give the symbol of the particles with the highest mass

(1 mk)

- (b) (i) Find the values of Z_1 and Z_2 in the nuclear equation below

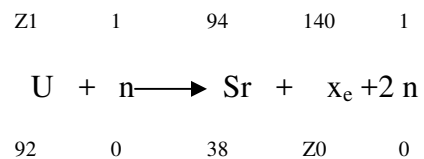

- (ii) What type of nuclear reaction is represented in b (i) above? (1 mk)

15.

(a) State the difference between chemical and nuclear reactions (2mks)

(b) Below is a radioactive decay series starting from

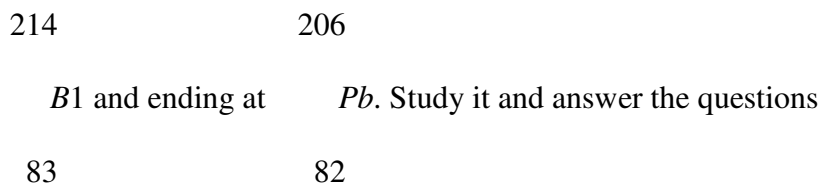

that follows

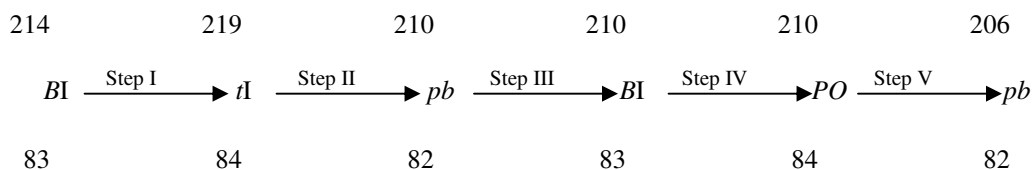

(i) Identify the particle emitted in step I and III. (2mks)

(ii) Write the nuclear equation for the reaction which takes place in step V (1 mk)

(c) The table below gives the percentage of radioactive isotope of Bismuth that remains after decaying at different times.

Time (min)	0	6	12	22	38	62	100
Percentage of Bismuth	100	81	65	46	29	12	3

(i) On the grid provided plot a graph of the percentage of bismuth remaining (vertical axis) against time (3mks)

(ii) Use the graph, determine the
I. Half life the Bismith (1 mk)

II. Original mass of bismuth isotope given that the mass remained
after 70 minutes was 0.16g (2mks)

d. Give one use of radioactive isotope in medicine (1 mk)

16. Copper 64 has a half life of 12.8 his

(a) What is meant by half life? (1 mk)

(b) Draw a graph to show the decay of copper 64 from an initial activity to 64
counts per minute to four percent minutes (4mks)

17. Complete the following nuclear equations

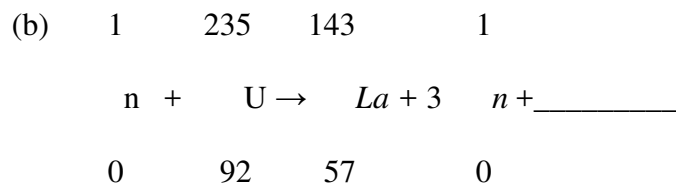
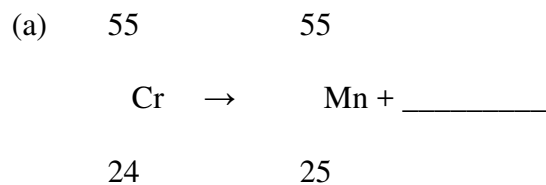

18. A quality of ^{11}X was mentioned with a G.M tube scalar. The following results were obtained over a period of 70 minutes.

Time	Cents per minute
0	800
10	560
20	427
30	305
40	225
50	165
60	122
70	85

- (a) Plot a graph of time against the counts per minutes (4mks)
- (b) Determine the half life of ^{44}X (3mks)
- (c) Starting with 32g, of ^{44}X how much of the isotope would be remaining after 110 minute? (3mks)
19. Study the nuclear reaction and answer the questions that follows

238

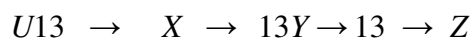

92

Determine the mass number and atomic numbers of X, Y and Z

20. (a) When a stream of low energy particles is directed towards a thin of aluminium, the following observation are made
- (i) Most of particles pass straight the foil
 - (ii) The remaining ones are either deflected or emerge from the same as they originally entered (4mks)
 - (iii) If the energy of the particles is increased, some are absorbed by the aluminium foil comments on this observation. (4mks)

31

21. The isotope ${}^X_{14}$ has a half life of 2.5 hours

14

Calculate the % (percentage) of a given mass of the isotope left after 7.5 hours

(1 mk)

22. Below is a diagram of a deflection and penetrating powers of three radiations from a radioactive source

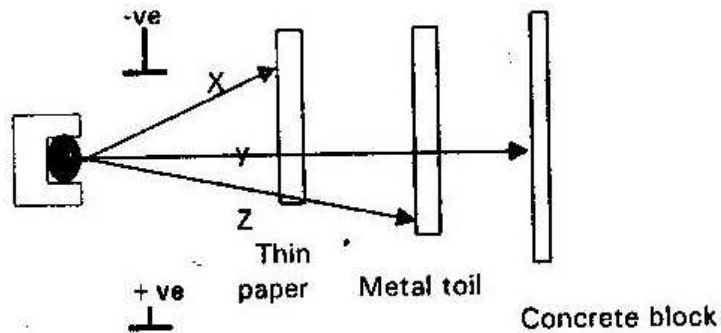

- (a) Name the radiations labeled X, Y and Z (3mks)
- (b) Why are radiation X stopped by a thin piece of paper

23. Complete and balance the following nuclear reaction (3mks)

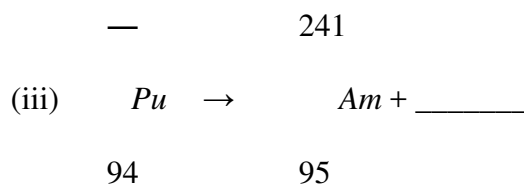
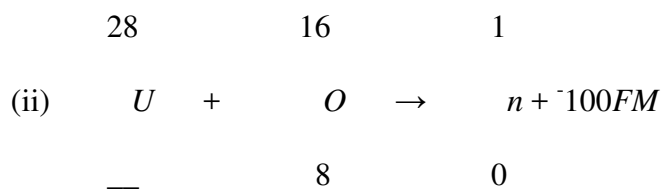
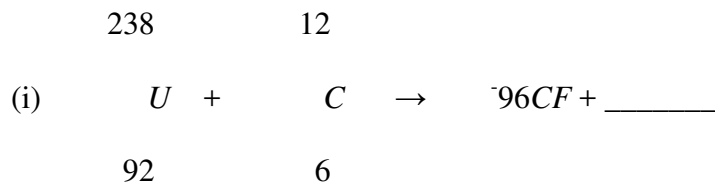

ANSWERS TO TOPICAL QUESTIONS

TOPIC 1

SIMPLE CLASSIFICATION OF SUBSTANCES

1.

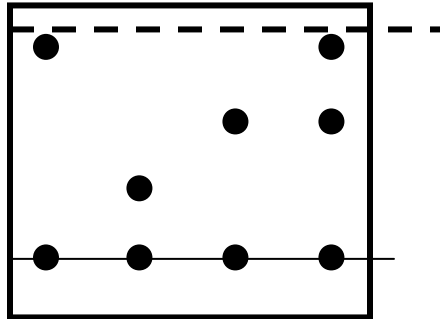

W X Y K

2. To the mixture of sugar, camphor and alum, add either camphor dissolves leaving behind alum and sugar. Filter the mixture to obtain sugar and alum a residue. Add ethanol to this residue sugar will dissolve leaving behind alum as a residue. Filter the mixture, sugar will be in a solution of ethanol (filtrate) allow the filtrate to evaporate and solid sugar will be left behind.
3. (a) In both cases the energy/ heat added is used to separate/ split/ weaken the

bonds holding the particles together. We call this energy latent heat of fusion.

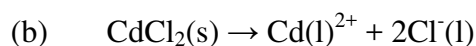

This is because CdCl_2 is an ionic compound where the particles (ions) are held together by strong electrostatic force of attraction – compared to weak Vanderwaal forces and hydrogen bonds holding the molecules of water together.

4. (a) Pass the mixture of gas “D” and “E” through sulphuric acid. Gas “D” will react to form salt- leaving behind gas “E” Collect gas E by downward delivery/ upward displacement of air since it is heavier than air.

OR

Pass a mixture of gas “D” and “E” over sodium hydroxide. Gas “D” will dissolve but gas “E” will not be affected. Collect gas “E” by downward delivery



Ammonia is lighter than air. It reacts with acids to form salt since itself is basic. It does not react with sodium hydroxide since both are basic but will dissolve in it without any reaction.

5. Compress and cool the mixture to a temperature below 196°C i.e. (-200°C) to form liquid air. Allow the mixture to expand and warm. Nitrogen will vaporize

- first since it is more volatile. Oxygen will start to vaporize when a temperature of -183°C is attained.
6. (a) – The thermometer is touching the mixture
- Direction of flow of water in the liebig's condenser reversed
 - Naked flame used to heat organic compound and yet they are flammable.
- (b) – Test the boiling point or
- Test the freezing point or
 - Test its density or
 - Its refractive index
7. Add water to the mixture and stir, sodium chloride will dissolve leaving behind copper (II) oxide. Filter the resulting mixture the filtrate will contain dissolved sodium chloride. Evaporate the filtrate to dryness to obtain solid sodium chloride.
8. (a) Liebig's condenser
- (b) Determine the point at which one of the liquids in a mixture has evaporated completely. Temperature tends to remain constant when one liquid in a mixture is evaporating.
- (c) Liquid "C" since it is more volatile
9. (a) $3\text{Mg(s)} + \text{N}_2(\text{g}) \rightarrow \text{Mg}_3\text{N}_2(\text{s})$
- (b) Argon
- Helium

Krypton

Xenon

The above mentioned are rare/ un-reactive gases and do not combine with other substances easily

10. (a) Reduction process
(b) Oxygen is removed from lead (II) oxide it's reduced into lead metal
(c) – Hydrogen gas
- Ammonia gas
11. C- Unburnt gas D- Luminous yellow flame
12. (a) G (b) A₁
13. (a) Cooling (b) Latent heat of fusion
14. (a) A black mass of substance which is spongy will be formed. A lot of heat is given out. This is a chemical reaction. The formula of new substances are
C for carbon
H₂ O for water vapour
(b) A purple vapour is formed that condense at the cooler part of the test tube as grey crystal. This is a physical change. No new compound is formed

- (c) A brownish gas is produced another gas lights a glowing splint. A black substance is left in the tube. This is a chemical change. The formula of new substances

Copper (II) Oxide CuO

Nitrogen (IV) Oxide NO_2

Oxygen gas O_2

- (d) The pellets melts forming a colourless solution.

Type of reaction physical or chemical

Formula Na_2CO_3 and H_2O

Ps Sodium hydroxide is deliquescent it can also react with CO_2 in solution to give sodium carbonate and water.

15. (a) Fractional distillation

- (b) (i) Add water to the mixture. Stir. Sodium chloride being ionic dissolves. Filter the mixture to remove sulphur as a residue.

Evaporate the filtrate to obtain solid sodium chloride

- (ii) Determine the melting point, pure sulphur melts at 114°C OR

Pure sulphur will have constant/ sharp boiling point

- (c) (i) Potassium bromide/ KBr

(ii) $60 - 55 = 5\text{g}$ (units a must)

(iii) Fractional crystallization

(iv) Separation of components of trona from lake Magadi

- Manufacture of Na_2CO_3
- Manufacture of NaCl
- Extraction
- Production

16. Pass the air through a filter to remove dust, then bubble it through potash solution to remove CO_2 ; cool and compress the remaining air to get liquid air. Warm and allow it to expand. Nitrogen b.p -196°C vaporizes first.
17. (a) Fractional Distillation
 (b) Paper chromatography
 (c) Sublimation
 (d) Use of a magnet
18. (a) (i) Over water
 (ii) Upward delivery/ downward displacement of air
 (iii) Downward delivery/ upward displacement of air
 (b) (i) Fractional distillation
 (ii) Upward delivery: It is less dense than air
 (iii) Downward delivery: it is denser than air
19. (a) Fractional distillation
 (b) Round bottom flask: Fractionating column, Liebig's condenser, thermometer, means of heating.

- (c) Not to heat the mixture in open/ naked flame since the liquids are flammable. Use water bath
20. (a) Carbon (IV) Oxide is removed in step I and oxygen removed in step II
(b) Step I – concentrated sodium/ potassium hydroxide
Step II – Heated metal e.g. copper
21. Heat the mixture naphthalene will sublime leaving behind common salt. Cool the sublimate to get solid naphthalene.
22. (a) (i) The solution was saturated
(ii) The remaining solid will dissolve. This is because increase in temperature increases the solubility of potassium nitrate.
(iii) Crystals will be formed
- (b) (i) Copper Nitrate and Sodium Sulphate/ soluble salt of copper and soluble sulphate salt.
(ii) $\text{Cu}^{2+}(\text{aq}) + \text{SO}_4^{2-}(\text{aq}) \rightarrow \text{CuSO}_4(\text{aq})$

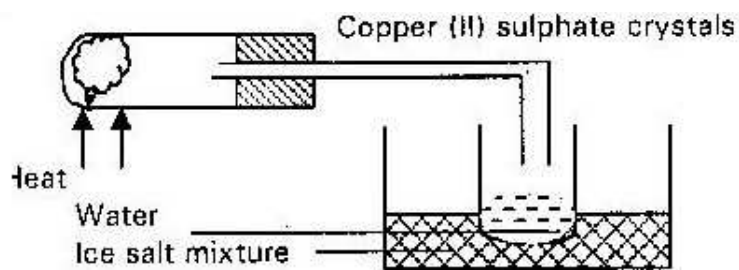

(iii) The solid will change from white to blue crystals. Heat will be produced. A chemical reaction will occur and anhydrous copper (II) sulphate will be hydrated.

23. (a) Heat water steadily

Thermometer should not touch the beaker

Stir the naphthalene continuously

(b) (i) Determine the temperature

(ii) Stir the naphthalene so as to distribute heat evenly

(iii) Transfer heat to naphthalene so as to melt it.

(c) - Presence of impurities

- Experimental errors

- Heat loss to the surrounding

24. (a) Lime water

(b) White precipitate

(c) $\text{CO}_2(\text{g}) + \text{Ca}(\text{OH})_2(\text{aq}) \rightarrow \text{CaCO}_3(\text{s}) + \text{H}_2\text{O}(\text{l})$

25. - To protect potassium from moisture and dry oxygen with which they react

- Phosphorous reacts with dry oxygen not moist oxygen

26. Dissolve the moisture in cold water and stir R dissolve. Filter to get solid “S” and “V” as residue. Evaporate the filtrate to get R. Put “S” and V in hot water and stir. V dissolve filter to get S as a residue. Evaporate filtrate to get V.

TOPIC 2

ACIDS, BASES AND INDICATORS

1. White precipitate, which dissolve in excess of sodium hydroxide to give a clear/colourless solution.
2. Concentrated sulphuric acid is a covalent compound. Dilute sulphuric acid is an ionic compound. It ionizes fully producing more hydrogen ions (H^+)
3. The evolution of carbon (IV) oxide increases with time then remains constant. Initially there were many particles reacting together. After 20 seconds all calcium carbonate were used up and the reaction came to a completion.
4. M $Zn(NH_3)_4^{+2}$
N $Zn(OH)_4^{-2}$
5. Nitrous acid ionizes more compared to hypochlorous acid. Hypochlorous acids is a very weak acid. It ionizes partially producing few hydrogen ions(H^+)
6. B Strong acidic
C Weak acidic
D Strong basic

7. Carbonate reacts with acid producing carbon (IV) Oxide which is weaker acidic in presence of water. It changes litmus to pink. Sulphite on the other hand reacts with dilute acid producing sulphur (IV). Oxide which is a strong acid in presence of water. It changes litmus to red.

8. NH_4^+ acts as an acid

It donates proton (H^+) to $\text{H}_2\text{O}(\text{l})$ and converts it to hydroxonium ion (H_3O^+).

H_3O^+ act as an acid in the backward reaction as it donates proton to $\text{NH}_3(\text{g})$ and convert it to $\text{NH}_4^+(\text{aq})$.

9. React Lead Carbonate with dilute Nitric acid to get a solution of lead Nitrate.



Dissolve potassium sulphate in water to get its solution. Mix potassium sulphate solution with Lead Nitrate Solution to obtain Lead Sulphate as a precipitate.

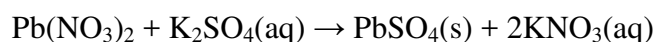

Filter the resulting mixture to obtain Lead sulphate as a residue. Wash it with distilled water and dry it.

10. Strong acid is the one which ionizes fully producing more hydrogen ions when in solution with water e.g.

- Hydrochloric acid

- Nitric acid

- Sulphuric acid

Weak acid is the one which ionizes partially in solution of water producing few hydrogen ions e.g.

- Ethanoic acid

- Propanoic acid

11. Add excess Lead (II) Carbonate to Nitric acid. Wait for the reaction to be completed. Filter the resulting solution mixture. To the filtrate (Lead Nitrate) add excess dilute hydrochloric acid. Filter the mixture to get lead (II) chloride.

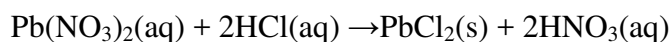
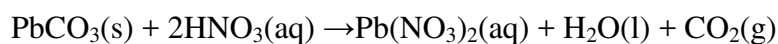

12. Sting from the bee contains Histamine which is acidic. This causes irritation. Sodium hydrogen carbonate being alkaline/ basic neutralizes the acid to remove the irritation.

13. The blue crystal change to a white powder. Conc sulphuric acid is a dehydrating agent. It removes water of crystallization from hydrated copper (II) sulphate.

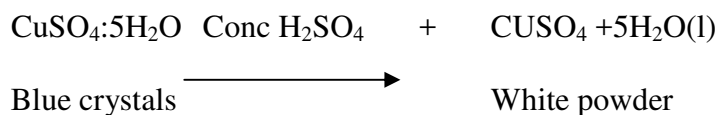

14. Moles of $\text{HNO}_3 = \frac{\text{Molarity} \times \text{Vol}}{1000} = \frac{2 \times 50}{1000} = 0.1$ moles

Moles of KOH in $50\text{cm}^3 = 0.1$ moles

Moles of KOH in $100\text{cm}^3 = 0.1 \times 2 = 0.2$ moles

Mass of D = $0.2 \times 56 = 11.2\text{g}$

15. (a) Brown ring where the layers of acid meets the layer of the nitrate and sulphate.

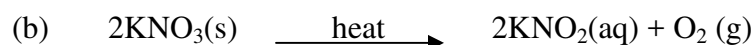

16. React with sodium hydrogen carbonate to form carbon (IV) Oxide which causes the dough to rise as it tries to escape.

17. - To neutralize soil acidity

- Add Ca^{2+} ions to the soil which is needed by plants i.e. it acts as a fertilizer.

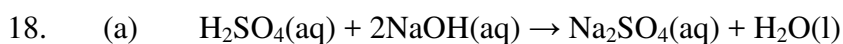

(b) Blue litmus paper change to red. The red litmus remained red.

(c) The acid used was in excess i.e

Moles of both acid and bases are

$$\frac{30 \times 0.1}{1000} = 0.003 \text{ moles}$$

1000

But NaOH: H_2SO_4 reacts in the ratio of 2:1

Hence we expect 0.003 moles of NaOH to react with 0.0015 moles of

H_2SO_4 . The acid was in excess by 0.0015 moles.

19. (a) Pb^{2+}
 (b) Zn^{2+}
 (c) $\text{CO}_3^{2-}(\text{aq}) + \text{Zn}^{2+}(\text{aq}) \rightarrow \text{ZnCO}_3(\text{s})$
20. Hydrochloric acid is a strong acid. It ionizes fully in solution of water. Therefore there are more hydrogen ions to be displaced by magnesium. Ethanoic acid is a weak acid. It ionizes partially in solution of water. It contains few hydrogen ions to be displaced by magnesium.
21. (a) Ammonia gas reacts with water producing ammonia solution

$$\text{NH}_3(\text{g}) + \text{H}_2\text{O}(\text{l}) \rightarrow \text{NH}_4\text{OH}(\text{aq})$$
 Ammonia solution is a weak alkali. It ionizes partially producing hydroxyl ions $[\text{OH}^-]$. The $[\text{OH}^-]$ ions changes red litmus to blue.
- (b) The funnel prevents the sucking back of water as ammonia is very soluble in water.
22. (i) $\text{ZnO}(\text{s}) + \text{H}_2\text{SO}_4(\text{aq}) \rightarrow \text{ZnSO}_4(\text{aq}) + \text{H}_2\text{O}(\text{l})$
 (ii) $\text{ZnO}(\text{s}) + 2 \text{NaOH}(\text{aq}) \rightarrow \text{Na}_2\text{ZnO}_2(\text{aq}) + \text{H}_2\text{O}(\text{l})$
- (b) Zinc oxide is amphoteric in nature

23. Acid "L" is a weak acid. It contains few hydrogen ions to be displaced by magnesium. Acid "M" is a strong acid. It ionizes fully. There are more hydrogen ions (H^+) to be displaced by magnesium.
24. (a) Copper (II) Hydroxide $[Cu(OH)_2]$
(b) Tetra – amine copper (II) ions $[Cu (NH_3)_4^{+2}]$
25. The product from nettle plant is acidic aqueous ammonia solution being basic neutralize the acidic product.
26. (a) (i) Colour change from green to brown
(ii) Reddish brown precipitate
(b) $Fe^{3+}_{(aq)} 3OH^-_{(aq)} \rightarrow Fe (OH)_{3(s)}$
27. (a) O^{-2}
(b) $[Zn(OH)_4]^{-2}$
28. $Zn(s) + H_2SO_4(aq) \rightarrow ZnSO_4(aq) + H_2(g)$
 $Zn(s) + 2H_2SO_4(l) \rightarrow ZnSO_4(aq) + SO_2(g) + 2H_2O(l)$
29. Amphotric
30. (a) Neutralization

- (b) (i) Calcium hydrogen carbonate
(ii) Drying agent, extraction of sodium
31. (a) (i) Hygroscopy
(ii) Deliquescence
(iii) Efflorescence
- (b) (i) Zn(OH)_4^{-2}
(ii) $\text{NH}_4(\text{NH}_3)_4^{+2}$
- (c) (i)

Elements	Fe	S	O	H ₂ O
% by mass	20.2	11.5	23.0	45.3
RAM	56	32	16	18
Moles	<u>20.2</u>	<u>11.5</u>	<u>23.0</u>	<u>45.3</u>
	56	32	16	18
Ratio	<u>0.36</u>	<u>0.36</u>	<u>1.44</u>	<u>2.56</u>
	0.36	0.36	0.36	0.36
	1	1	4	7

$\text{FeSO}_4 \cdot 7\text{H}_2\text{O}$

- (iii) Moles of salts = $\frac{\text{mass}}{\text{RMM}} = \frac{6.95}{278} = 0.025$ moles

$$\text{Molarity} = \frac{\text{moles} \times 1000}{\text{Volume}} = \frac{0.025 \times 1000}{250} = 0.1\text{M}$$

32. (a)

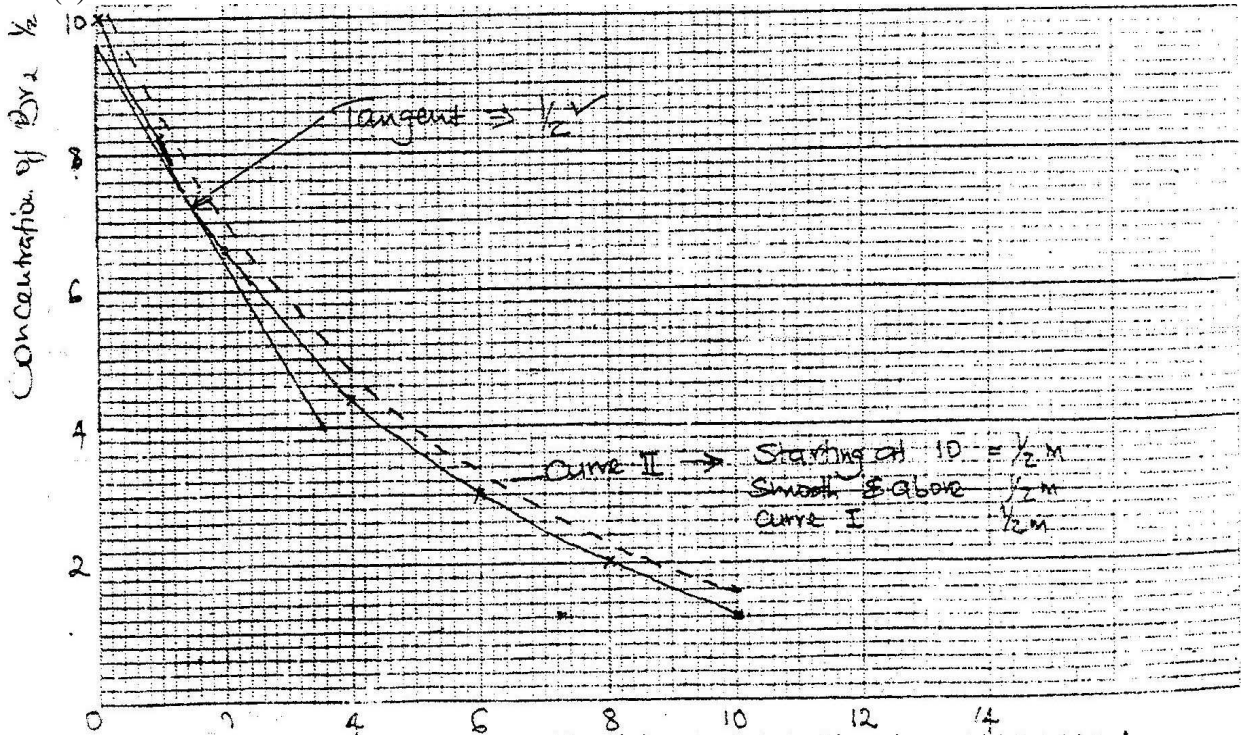

(b) (i) Conc of Br₂ after 3 minutes $5.3 \times 10^{-3} \text{ mol/dm}^3 \pm 0.1$

(ii) Change in concentration

Change in time

$$\frac{(9.6 - 5.0) \times 10^{-3}}$$

$$3-0$$

$$= 1.53 \times 10^{-3} \text{ mol/dm}^3$$

(c) At high concentration the rate of reaction is high because the particles in the solution collide at a high frequency or more particles collide more often.

(d) At a lower temperature the particles have less kinetic energy hence frequency of collision is reduced or few particles have activation energy.

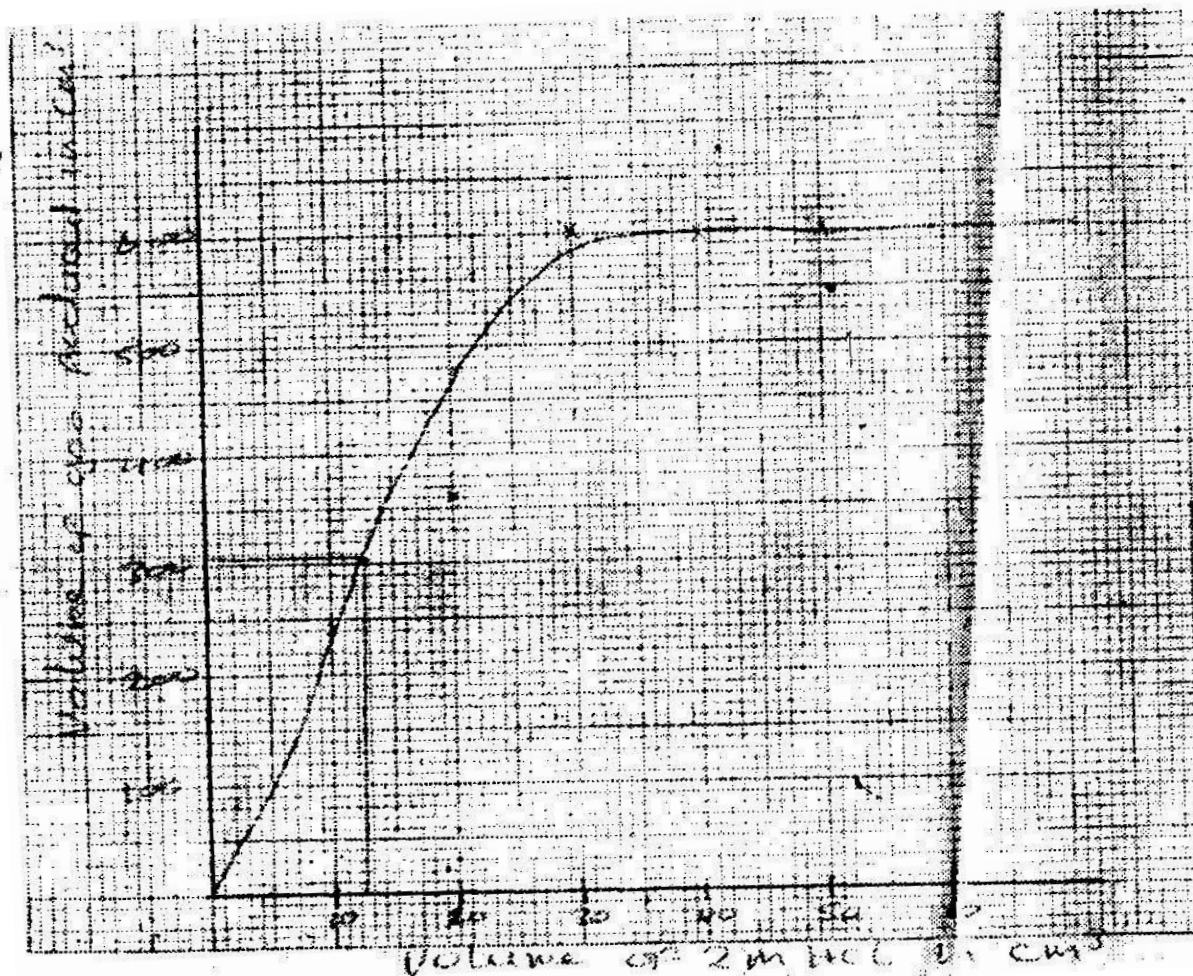
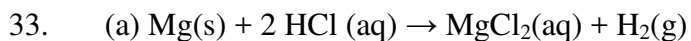

- (c) (i) $300\text{cm}^3 \pm 10\text{cm}^3$ depending on the scale
- (ii) The volume of 2M HCl which reacted completely with 0.6g of Mg powder is 30cm^3
- (d) (i) The rate of reaction will be lowered. Magnesium ribbon has a small surface area that the powder. Hence the collision of particle between magnesium particles in a ribbon and hydrochloric acid particles will be reduced.
- (ii) Rate is increased since the number of particles of HCL hydrochloric acid will be higher/ concentration is increased. Hence particles collide more frequently.

(e) Moles of hydrogen gas produced = $\frac{600\text{cm}^3}{240000\text{cm}^3}$

= 0.25 moles

\therefore Moles of mg = 0.25 moles

\therefore RAM of mg = $\frac{0.6}{0.25} = 24$

0.25

34. (a) - Malachine
- Copper pyrite
- Chalcosite
- Cuprite

- (b) (i) Hydrogen Sulphide / $\text{H}_2\text{S}(\text{g})$
-Soluble carbonate i.e sodium carbonate Na_2CO_3 / potassium carbonate/ K_2CO_3 - including their bicarbonate $\text{KHCO}_3/\text{NaHCO}_3$
-Copper (II) Oxide/ CuO



(iii) Step 4

- Green Solid dissolves to form blue solution
- Effervescence and bubble of colourless gas which forms precipitate with lime water are produced

Step 7

Black solid dissolves to form a blue solution.

- (c) (i) Tin/Sn
- (ii) Ornaments/ medals/ bearing metals in machines/ coinage/ gear wheels
Earrings/ door handles/ electrical contact.

35. (a) (i) Put soil in water in a beaker. To the mixture add universal indicator. Compare the colour change to the Ph Chart.
- (ii) Addition nitrogenous fertilizer which are acidic.
36. (i) Q
- (ii) Pink/Red

37. (a) Number of hydrogen ions (H^+) which can be displaced by a metal or ammonium radicals to form salts
- (b) Ethanoic acid had a basicity of one (i) since one hydrogen ion in the carboxalate group ($-COOH$) can be displaced
38. (i) Yellow in acidic medium: The H^+ ions of the acid react with OH^- from indicator producing more H_2O . The equilibrium shift to the right side.
- (ii) Blue in alkaline medium. The OH^- ions/ radicals from alkaline solution increases the concentration to the right. Equilibrium shift to the left side.
39. K^+ and CO_3^{-2}
 Na^+ and CO_3^{-2}
40. (i) C
(ii) D
(iii) B
(iv) A
41. (a) C
(b) A
(c) D

42. (a) Dirty green precipitate is formed

Observations

Dirty green precipitate changed to give a reddish brown precipitate

(b) (ii) Explanation

Iron (II) hydroxide which is green is oxidized to iron (III) hydroxide by oxygen in the air

43. Strong acid is the one which ionizes fully while in solution with water

Weak acid ionizes partially while in solution with water

44. NaOH(aq) → Solution D

CH₃COOH(aq) → Solution C

HCl (aq) → Solution B

NH₃(aq) → Solution A

45. (a) Fe(s) + H₂SO₄(aq) → FeSO₄(aq) + H₂(g)

(b) (i) Dirty green precipitate formed

(ii) Fe²⁺ (aq) + 2OH⁻(aq) → Fe(OH)₂(s)

(c) (i) 2Fe²⁺ (aq) + 4H⁺ (aq) + 2NO₃⁻ → 2Fe³⁺(aq) + 2NO₂ + 2H₂O(l)

(ii) Oxidizing agent: It oxidizes Iron (II) (Fe²⁺) to iron (III) compound (Fe³⁺)

(d) (i) Green solution will be formed

(ii) Zinc acted as reducing agent. It reduces Iron (III) (Fe^{3+}) to iron (II) Compound (Fe^{2+}) which is green.

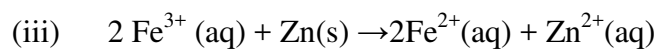

TOPIC 3

AIR AND COMBUSTION

1. (a) The blue litmus paper would turn pink/ red. Red litmus paper remains red.
The carbon (IV) oxide produced when the candle burns dissolves in water to form a solution of weak carbonic acid.

(b) $\frac{x-y}{x} \times 100\%$

x

2. Observation: At No rusting takes place

Explanation: Zinc is more reactive than iron. It reacts with oxygen in presence to iron hence preventing it from rusting. It acts as a sacrificial metal

Observation at B

The nail is covered by reddish brown substance/coating/rust

Explanation: Copper is less reactive than iron. Iron combines first with oxygen in presence of moisture and rust.

3. (a) To remove the layer of oxide on their surfaces which could inhibit the reaction

(b) Q, R,P

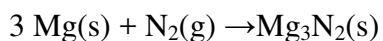
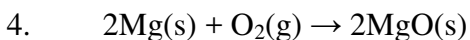

5. Oxide: Highest oxidation number

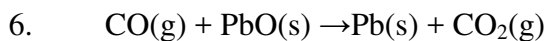
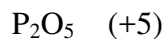

Observations

7. -Iron will be covered by a reddish brown substance/coating/rust

-Water in test tube rise and water in a beaker drops

Explanation:

Iron Combines with oxygen in a presence of moisture to form hydrated Iron (III) oxide / rust water rises up to occupy the space which was occupied by oxygen in the tube.

8. Al_2O_3 (Aluminium Oxide)

9. Change was greatest with Magnesium. Both react with oxygen gas to form oxides, but magnesium also reacts with nitrogen to form magnesium nitride (Mg_3N_2)

10. (i) Mass increase: Oxygen combines with copper metal to form copper (II) Oxide.

(ii) Mass decrease: copper Nitrate decomposes to give gases that escape leaving behind copper (II) oxide.

11. Magnesium is above iron in the reactivity series. It supply electrons to the iron bar hence prevent it from rusting/ cathode protection.
12. Magnesium produces a lot of heat/ energy when burning. This splint sulphur (IV) oxide into sulphur and Oxygen. Magnesium burns in the oxygen produced. Burning splint produces less energy which is not enough to break sulphur (IV) oxide.
13. (a) Manganese (IV) Oxide/ $\text{MnO}_2(\text{s})$
- (b) $2 \text{H}_2\text{O}_2 (\text{aq}) \xrightarrow{\text{MnO}_2} 2 \text{H}_2\text{O}(\text{l}) + \text{O}_2$
- (c) - Respiratory aids from patients suffering from respiratory diseases / during surgery.
- High mountain climbers and deep see divers
- Helps in combustion of rocket fuel
- Welding together with other gases such as hydrogen/ oxygen (hydrogen flame) acetylene/ oxyacetylene flame.
14. Nitrogen (II) Oxide is oxidized by oxygen in air to form nitrogen (IV) oxide. This gas is acidic when dissolved in water. May cause acidic rain. If inhaled by animals/ man may corrode respiratory surfaces exposing them to disease causing agents.

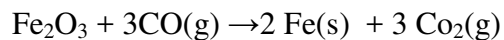
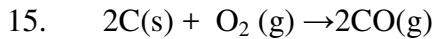

16. (i) SO_2 / sulphur(IV) Oxide

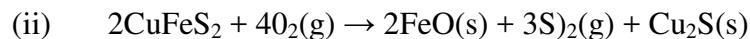

(iii) Fe^{2+}

(iv) Carbon (IV) Oxide or carbon (II) Oxide

(v) Reduction/ oxidation = Redox since Cu_2O is reduced to Cu and CO oxidized to CO_2

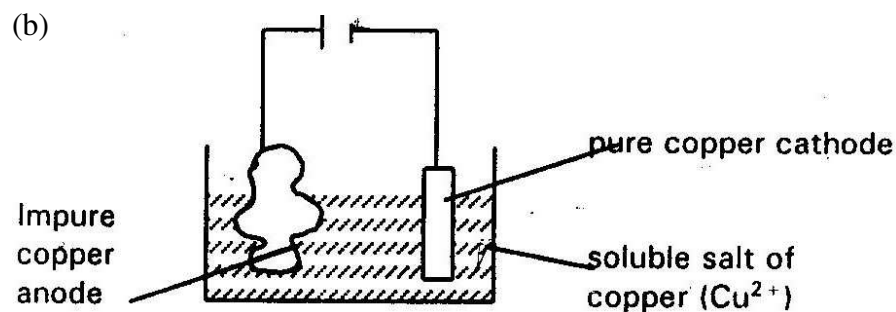

(c) Mole ratio of CU in $\text{CuFeS}_2 = 1.1$

Moles of Cu produced = $\frac{210}{63.5} = 3.3$ moles

63.5

RFM of $\text{CuFeS}_2 = 63.5 + 56 + 64 = 183.5$

Mass of Cu in $\text{CuFeS}_2 = 3.3 \times 183.5 = 605.6$ kg

% purity = $\frac{605}{810} \times 100 = 74.76\%$

810

- (d) - Formation of acidic rain due to presence of sulphur (IV) oxide
- Sulphur (IV) oxide is poisonous
- Carbon (II) is poisonous
- Global warming due to presence of carbon (IV) oxide
- Dumping of wastes like slag prevents growth of vegetation
- Soil erosion due to the excavation of the ores

17. (i) Bitumen: It has the highest boiling point
- (ii) Fractional distillation: they have different boiling points, petrol boils out first
- (iii) Each component is a mixture of hydrocarbons/ impure or there is presence of isomers in each component.
- (iv) Methane \rightarrow CH_4 all alkane gases up to $\text{C} = 4$
- (b) Burning in limited air will produce carbon (II) oxide which is poisonous
- (c) - Manufacture of tar used in tarmac road/ surface of roads
- Amending leaking roofs.

18. (a) (i)

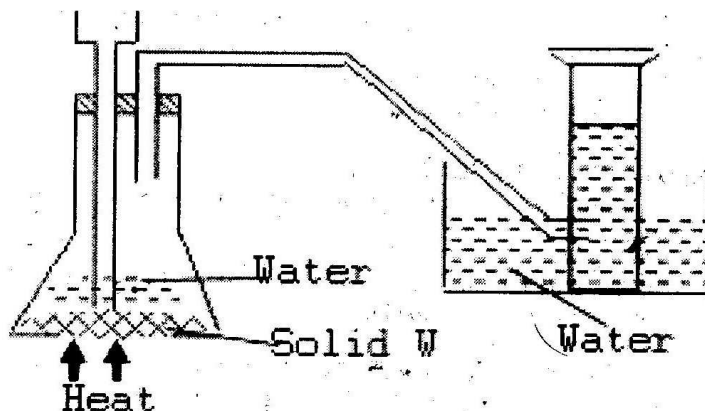

- (ii) Sodium peroxide Na_2O_2
- (b) (i) $4\text{P}(\text{s}) + 5\text{O}_2(\text{g}) \rightarrow 2\text{P}_2\text{O}_5(\text{g})$
- (ii) Phosphorous (V) oxide dissolves in water to form an acid
(Phosphoric acid)
- (c) A firm oxide (aluminium Oxide) is formed on the surface of the metal.
This oxide protect aluminium from further attack
- (d) (i) A reaction which proceeds by production of heat i.e heat is lost to the surroundings.
- (ii) The yield be lowered: through by Le- Chateliers principle, the yield is expected to increase. But lower temperatures will result into fewer particles attaining activation energy.
- (iii) $\text{RMM of SO}_3 = 32 + 48 = 80$
Moles of SO_3 used = $\frac{350}{80} = 4.38$ moles
- 80
- Moles of $\text{H}_2\text{S}_2\text{O}_7 = 4.38$ moles

$$\text{RMM of H}_2\text{S}_2\text{O}_7 = 2 + 64 + 112 = 178$$

$$\text{Mass of H}_2\text{S}_2\text{O}_7 = 4.38 \times 178 = 779.6 \text{ kg}$$

19. (a) (i) Potassium Hydroxide or sodium hydroxide
- (ii) Air allowed to expand and warm up. Nitrogen gas vaporizes first since it is more volatile. On further heating- oxygen vaporizes.
- (b) (i) Hydrogen gas
- (ii) - For the complete oxidation of ammonia gas
- To increase the yield of nitrogen (II) Oxide
- To reduce the cost
- (iii) Nitrogen gas
- (iv) $\text{NH}_3(\text{g}) + \text{HNO}_3(\text{aq}) \rightarrow \text{NH}_4\text{NO}_3(\text{aq})$
- (c) Brown gas (Nitrogen (IV) Oxide gas) and an acidic gas (sulphur (IV) oxide) formed
- Nitric acid reduced into nitrogen (IV) oxide, water and oxygen. Sulphur is oxidized into sulphur (IV) oxide which dissolves in water forming sulphuric acid.
20. (a) Carbon and hydrogen
- (b) (i) The candle will go off/ extinguished since carbon (IV) oxide and water vapour accumulate around the candle carbon (IV) oxide does not support burning.
- OR The supply of oxygen will be supported and candle goes off

(ii) Mass increase

Water combines with calcium oxide to form calcium hydroxide solution. This combine with carbon (IV) oxide to form calcium carbonate.

(iii) - Carbon (IV) oxide

- Carbon (II) oxide

(iv) Protect calcium from obtaining water from the atmosphere

(v) -Concentrated sulphuric acid

-Calcium chloride

21. Iron metal is corroded by rust in presence of water and oxygen

22. There will be formation of a white precipitate. Candle burns producing carbon (IV) oxide.

23. Air contains carbon (IV) Oxide which dissolve in water producing a weak carbonic acid

24. Na + ions

25. $3\text{Mg(s)} + \text{N}_2\text{(g)} \rightarrow \text{Mg}_3\text{N}_2\text{(s)}$

$\text{Mg}_3\text{N}_2\text{(s)} + 6\text{H}_2\text{O(l)} \rightarrow 3\text{Mg(OH)}_2\text{(aq)} + 2\text{NH}_3$

26. (a) Beaker A: No soot at the bottom

Beaker B: A lot of black soot at the pattern

(b) Sample A: Non luminous flame produces a lot of heat.

(c)

Luminous	Non Luminous
- Produce a lot of light	- Produces less light
- Very sooty	- Not Sooty
- Large and wavy	- Short and steady
- Burns quietly	- Burns with roaring noise

27. (a) CO_3^{-2} is an oxidizing agent. It removes hydrogen from water (H_2O) and oxidizes it to OH .
- (b) Fe^{2+} is a reducing agent. It adds electrons to Cl_2 and reduces it to 2Cl^-
28. (a) To allow all oxygen to be used up and also to allow the gas to contract/ contract for any expansion of gases
- (b) To absorb carbon (IV) oxide which was produced by the burning candle
- (c) % of oxygen $\frac{90 - 70}{90} \times 100 = 22.2\%$

90

29. (a) Curve B: Pure substances has sharp/ fixed constant melting and boiling points
- (b) Impurities rises the boiling point pressure rises the boiling point i.e when pressure is high b.p is very high.

TOPIC 4

WATER AND HYDROGEN

1. i) If ignited immediately explosion would occur because it would still be mixed with air.

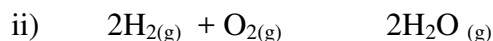

2.

Metals	Aqueous solution containing ions of metals		
	P	R	T
P	X	X	X
R	√	X	√
T	√	X	X

3. a) Sample II: because the volume of soap used is less i.e. 3.0 cm^3 and remains the same after boiling.

- b) Sample II is temporary hard water because after boiling it became soft.

Volume of soap change from 10.6 to 3.0 cm^3

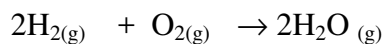
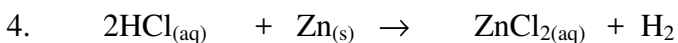

5. a) Moles of Zn = $\frac{1.96}{65.4} = 0.03$ moles

65.4

Moles of HCl: $\frac{100 \times 0.2}{1000} = 0.02$ moles

1000

Expected moles ratio of Zn: HCl

1:2

Moles reacting 0.01: 0.02

Moles of Zn were in excess by

$0.03 - 0.01 = 0.02$ moles

b) Moles of H_2 produced = 0.01 moles

Volume = $22.4 \times 0.01 = 0.224 dm^3$

OR $0.224 cm^3$

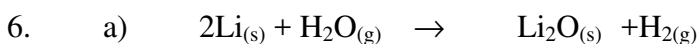

b) Potassium is very reactive and the reaction is likely to be explosive/violent.

7. a) to generate steam which will push air out.

b) Oxygen in air would oxidize zinc to zinc Oxide and no gas/Hydrogen would be produced.

c) It is less dense than air,

8. a) SO_4^{-2} and NH_4

b) From ammonium and sulphates based ferterlizers.

NH_4 can also be from humus- when they decay.

9. a) The Ca^{2+} and Mg^{2+} ions in the permutit

b) By passing a solution of concentrated sodium chloride/ brine through the permutit.

c) Provide Ca^{+2} ions necessary for bone and teeth formation.

-When passed through lead pipe the lead sulphate coat the inside as it is insoluble. This prevents chances of lead poisoning.

10. a) Cations: Al^{3+}
 b) Anions: SO_4^{2-}

$$\text{Ba}^{2+}_{(\text{aq})} + \text{SO}_4^{2-} \rightarrow \text{BaSO}_{4(\text{s})}$$
 c) a) $\text{H}_2\text{O}_{(\text{g})} + \text{mg}_{(\text{s})} \rightarrow \text{MgO}_{(\text{s})} + \text{H}_{2(\text{g})}$
11. a) $\text{H}_2\text{O}_{(\text{g})} + \text{Mg}_{(\text{s})} \rightarrow \text{MgO}_{(\text{s})} + \text{H}_{2(\text{g})}$
 b) It is insoluble in water.
12. a) Effervescence and bubbles of colourless gas were liberated.
 b) Copper turnings will settle at the bottom. There will be no reaction since copper does not react with an acid unless the acid is an oxidizing agent.
13. a) Presence of $\text{Ca}(\text{HCO}_3)_2$ and $\text{Mg}(\text{HCO}_3)_2$ salts which are soluble.
 b) During distillation pure water is evaporated and then condensed leaving behind solids $\text{CaCO}_{3(\text{s})}$ and $\text{MgCO}_{3(\text{s})}$ as their hydrogen carbonates decompose during the process.
14. It has one electron in its outermost energy level which it can lose to form H^+ showing oxidation state of +1 or gain one electron to form H^- showing oxidation state of -1.
15. $\text{H}_{(\text{g})} + \text{e}^- \rightarrow \text{H}_{(\text{g})}$

$$\Delta\text{H} = -\text{ve}$$

$$\text{H}_{(\text{g})} \rightarrow \text{e}^- + \text{H}^+_{(\text{g})} \quad \Delta\text{H} = +\text{ve}$$
16. a) $\text{H}_2\text{O}_{(\text{g})} + \text{C}_{(\text{s})} \rightarrow \text{H}_{2(\text{g})} + \text{CO}_{(\text{s})}$
17. a) SO_4^{2-} ions
 b) $\text{Ba}^{2+}_{(\text{aq})} + \text{SO}_4^{2-}$ Tetraamine zinc (II) ions
 c) $\text{Zn}(\text{NH}_3)_2$ and $\text{Ca}(\text{HCO}_3)_2$ decomposes producing CO_2 when heated.

18. a) Carbon (IV) Oxide gas
b) $\text{Mg}(\text{HCO}_3)$ and $\text{Ca}(\text{HCO}_3)_2$ decomposes producing CO_2 when heated.
19. a) No change in volume since the number of moles of acid is equal in both cases.
b) It is less dense and does not burn like hydrogen.
20. Changes anhydrous copper (II) sulphate from white to blue. Or changes cobalt chloride paper from blue to pink.
21. a) i) Add one drop of liquid to anhydrous copper (II) sulphate it will turn blue from white.

OR

Add one drop to anhydrous cobalt chloride; it will turn pink from blue.

- b) i) Large suspended particles e.g leaves, stones, sand, gravel/grit.
ii) Sedimentation or precipitation
iii) (a) Causes the small suspended particles to settle/precipitate.
(b) Destroy micro-organism
iv) a) Permanent hardness
- c) Addition of washing soda Na_2CO_3 which precipitates $\text{g}^{2+}_{(\text{aq})}$ as $\text{gCO}_{3(\text{s})}$.

22. a)

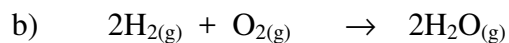
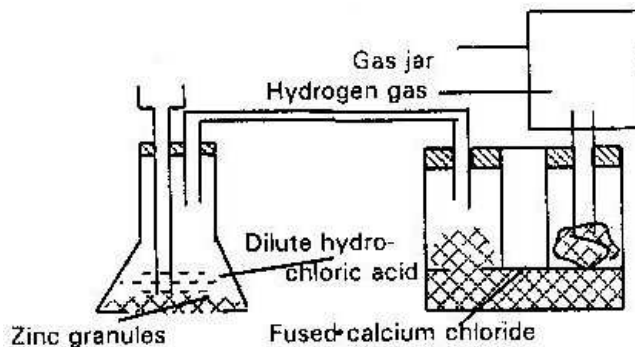

c) Moles of H_2 produced: $\frac{1.2}{24} = 0.05$ moles

\therefore Moles of Zn = 0.05 moles

\therefore Ram of Zn; $\frac{3.27}{0.05} = 65.4$

0.05

d) -Hydrogenation of fat

-Weather balloons

-Welding when mixed with other gases e.g oxygen to give oxyhydrogen.

23. i) Hydrogen

ii) Calcium hydroxide produced ionizes partially producing few (OH^-) ions

iii) Test the presence of carbon (IV) Oxide.

24. a) $2\text{Na}_{(s)} + 2\text{H}_2\text{O}_{(l)} \rightarrow 2\text{NaOH}_{(aq)} + \text{H}_2(g)$
 b) Sodium melts to form a silvery ball. Float on the surface and dart about.

Hissing sound produced.

25.	Na_2CO_3		X H_2O
	% mass	36.8	63.2
	RMM	106	18
	Moles	0.347	3.5
	Ratio	1	10

X = 10: Na_2CO_3 : $10\text{H}_2\text{O}$

26. a) -Lead oxide changes from yellow to brown when heated and finally grey shiny solid is formed.
 -Anhydrous cobalt chloride changes from blue to pink.

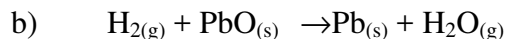

27. C, E, B, D

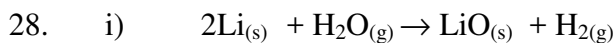

ii) Potassium is very reactive and the reaction may be violent/explosive.

29. (i) If the hydrogen gas is not removed from the system it will reduce the oxide of iron.

(ii) Weather balloon

Welding

Rocket fuel together with oxygen.

30. Hydrogen is more reactive than metal W since it is able to displace “W” from its oxide.
31. a) i) Sodium
ii) Copper
- b) i) sodium hydroxide/alkaline solution
ii) $2\text{Na}_{(s)} + 2\text{H}_2\text{O}_{(l)} \rightarrow 2\text{NaOH}_{(aq)} + \text{H}_2(g)$
- c) Sodium hydroxide is a strong alkali with a pH of 14.
This is because it ionizes completely in solution of water producing more hydroxyl (OH^-) ions.
- d) Pottassium and Rubidium
- e) Burns with a “pop” sound.
32. Deliquescent aborbs water from the atmosephere and dissolves.
Hygroscopic absorbs water from the atmosphere and becomes fissid i.e. it will float and helps in spreading of fire.

FORM TWO

TOPIC 1

STRUCTURES OF THE ATOMS AND THE PERIODIC TABLE

1. Proton = 27
Neutrons = 32
Electrons = 27
2. a) $X = 2:8::3$
 $Y = 2:8:6$
b) X_2Y_3
3. Hydrogen can gain one electron when combined with electronegative element to form H^- . Hence behave like group seven elements can also lose one electron to form H^+ i.e, behave like group one element.
4. a) Period 3
b) Y^{-3}
c) The ionic radius of Y is greater than its atomic radius Y reacts by gaining three electrons. The electrons added increases the repulsion / screening effect between the adjacent energy levels.

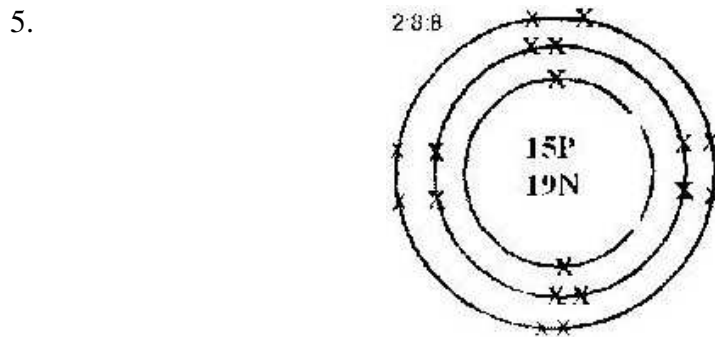

6. a) i) F, (ii) i
 b) J is in-group VI, period 3
7. a) K^+ has many electrons thus many energy levels. Na^+ has few number of electrons and thus few energy levels.
 b) Mg^{2+} contain large number of protons compared to Na^+ i.e the effective nuclear charge of Mg^{+2} ions is high, thus results into strong force of attraction between the nucleus and the electrons in their energy levels.
 Hence they are pulled close to the nucleus.

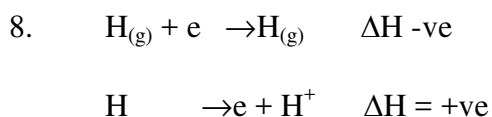

9. -Coinage, ornaments, soldering
 -Making, plumbing joints/musical instruments casing for bullets and bombs.

10. a) C and E contain equal numbers of protons/ atomic numbers.
 b) (I) Neutrons in b = 4
 (II) First ionization energy decreases with increase in atomic radius.
 When atomic radius increases the outermost electrons get further from the nucleus, less energy is thus required to remove it.

11 $RAM = \frac{(62.93 \times 69.09) + (64.93 \times 30.91)}{2} = 63.54$

100

12. Across the period there is a gradual increase in number of protons in the nucleus.
 This increases the force as attraction between the nucleus and the electrons.

13. a) They are both metals and need to lose electrons to be stable

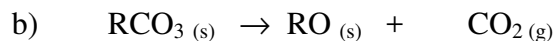

14. Atoms of the same elements with the same atomic numbers but different mass numbers.

15. a)

							R	S		
N	Q					V		T	U	
P										

b) U

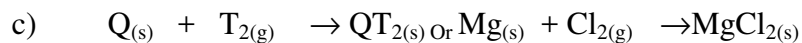

16. a) T 2:8:2

U 2:8:3

V 2:8:4

W 2:8:5

X 2:8:6

Y 2:8:7

b) Perion 3, they all contain three energy levels,

c) X has a small atomic radius compared to V. X has more protons so nuclear charge is higher hence attract outmost electrons more strongly.

d) U W

- e) Ionic bond/ electrovalent bond “T” will react with “Y” by donating its outer most electrons to the atoms of “Y”
- f) T^{2+} , T^{+2} , T
- (G) X^{-2} because it has a stable electronic arrangement of 2:8:8 X^{+2} has unsuitable electronic arrangement o (2:8:4)
- h) i) Acidic oxide VO_2 , W_2O_3 XO
 i) Basic Oxide TO
17. a) C =6
 H=1
 Na=11
 Ne= 20
- b) Ca^{2+} 2:8:8
 P^{-3} 2:8:8
- c) $-259 + 273 = 14k$
- d) Red phosphorous because it has a higher melting point.
- e) The one atomic number 24, because it is closer to the relative atomic mass (24.3), that means that it contribute to RAM more than the other two.
- f) Al_4C_3
18. (i) Alkaline earth metals.
 (ii) A: It has a stable electronic arrangement (duplet)
 (iii) Covalent bond. This because electrons are shared between B and E.
 (iv) G belong to group V, period 3
19. a) i) Alkaline metals

- ii) Energy required to remove an electron from an atom
- iii) "P" has the smallest ionic radius therefore, the outermost electrons are most strongly attracted to the nucleus, hence more energy is required to remove this electron.
- iv) Melts because the reaction is exothermic. Hissing sound because of the production of hydrogen gas. Float because it is less dense than water. Moves about due to propelling effect of escaping hydrogen.

b) A strong base ionizes completely in water producing more OH⁻ ions e.g KOH and NaOH. A weak base ionizes slightly producing few OH ions e.g NH₄ OH, Ca (OH)₂ and Mg (OH)₂

c) i) Reaction between H⁺ ions from the acid and OH ions from bases to form 1 mole of water.

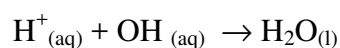

ii) Add 200cm³ of nitric acid to 200cm³ of 2m sodium hydroxide. Heat the mixture so as to make it saturated /concentrated. Allow the mixture to cool for crystals to appear. Filter/decant to obtain the crystals to appear. Filter /decant to obtain the crystals.

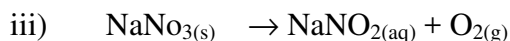

20. a) i)

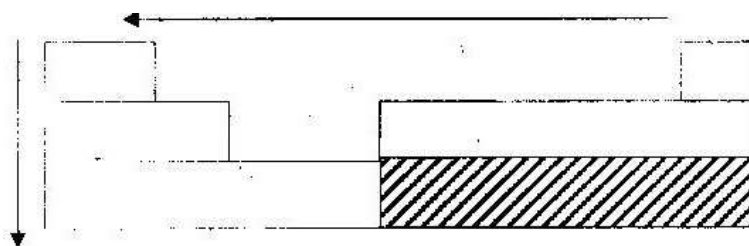

- ii) Non metals
- b) i) KA// KBr//KI any one
- ii) Ionic/ electrovalent: “K” loss of electron to form K^+ ions. “A” gains electrons to form A ions. Two ions combine to give KA.
- c) Add strong alkaline solution KOH //NaOH to Magnesium Sulphate solution to precipitate $Mg(OH)_{2(s)}$. Filter the filtrate to remove water. The residue is magnesium Hydroxide. Heat the hydroxide to remove water.
- Or
- Add soluble carbonate or hydrogen carbonate to the mixture. Magnesium carbonate will be formed. Heat the carbonate to get magnesium oxide.
- d) $Al(OH)_{3(aq)} + 3H^+_{(aq)} \rightarrow Al^{3+}_{(aq)} + 3H_2O_{(l)}$
- $Al(OH)_{3(s)} + OH^-_{(aq)} \rightarrow Al(OH)_4^-_{(aq)}$
21. Add aqueous sodium carbonate to precipitate calcium carbonate and magnesium carbonate and then filter to obtain pure brine.
22. a) Na^+ ions contain few electrons compared to K^+ which has large number of electrons. Na^+ has few energy levels.

- b) The ionic radius decreases from Na^+ to Al^{3+} . This is because there is gradual increase in numbers of protons in the nucleus. The added proton increases the attraction force between the nucleus and electrons.
23. a) W = Fe
 X = Na
 Y = Mg
 Z = Ca
- b) X, Z, Y, W

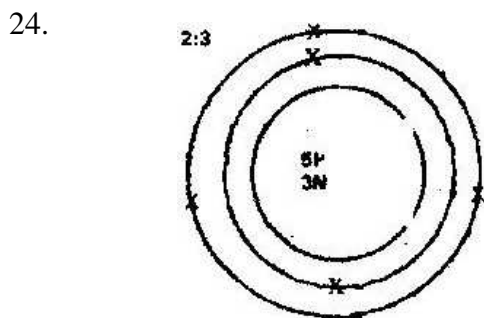

25. a) "G" it requires less ionization energy to pull out first electrons.
 b) Metallic group: atomic radius is large that the ionic radius.
26. a) i) "T" gain either react by gaining or losing electrons depending on the electro negativity of the element it is reacted with.
 ii) Alkali metals
 iii) "Y" is unreactive because it has stable electron arrangement i.e

octet structure.

- b) i) "Y" has a small atomic radius compared to X. Y has many number of protons in its nucleus hence attract electrons very strongly towards the nucleus.
- ii) "V" has a small atomic radius compare to "W". It can pull electrons to be gained very strongly i.e it has more electronegative. W can only react by sharing electrons.

- c) i)

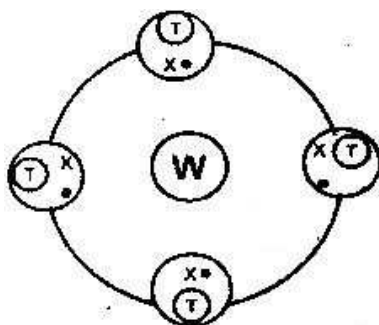

- ii) WT_4 is non polar molecule hence cannot dissolve in wate. It exist in form of simple molecular structure hence melting point is low.

d) i)

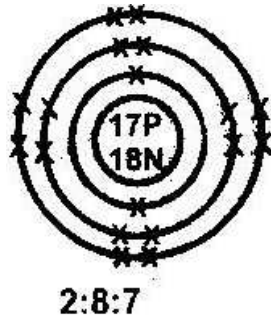

$$\text{ii) } \frac{(35 \times 3) + (37 \times 1)}{4} = 35.5$$

27. a) Isotopes refer to atoms of the same element with the same atomic numbers but different mass numbers.

$$\frac{(36 \times 0.34) + (38 \times 0.06) + (40 \times 99.6)}{100} = 39.88$$

28. a) $33 - 18 = 15$

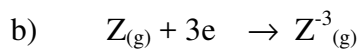

29. a) i) Hydrogen has (H_2)

ii) Iron (II) Sulphide (FeS)

iii) Hydrogen Sulphate (H_2S)

b) i) Burns with a pop sound

ii) Darken the paper which is soaked in lead acetate: (forms black precipitate with lead (Pb^{2+}) salts).

30. a) $E = 2,8,5$
- b) The chloride of E is in form of a simple molecular structure. The force holding the molecules together is weak van der Waals forces.
31. $\frac{(10 \times 18.7) + (11 \times 81.3)}{100} = 10.81$

100

TOPIC 2

CHEMICAL FAMILIES: PATTERNS IN THE PERIODIC TABLES

- X: it has a stable electronic arrangement i.e Octet structure.
 - “W” and “Y”
 - YW
- IV, II, I, III
- $T_{(s)} + X^+_{(aq)} \rightarrow T^{2+}_{(aq)} + X_{(s)}$
 - S, X, T, U
- B
 - C
 - D
- G 3, it has the smallest atomic size, therefore outermost electrons are strongly attracted by the nucleus. A lot of energy is required to remove the outermost electron.
- Element A= Sulphur, carbon, nitrogen
Element B = Sodium, potassium, lithium
- $F_2O_5 = O: 2F + - 10 = 0 \quad : 2F = 0+10$
 $F = \frac{+10}{2} = +5$
 - Group V
- The yellow liquid is PCl_3 . It is hydrolysed in air to form HCl which fumes since it absorbs water vapour from the atmosphere.
- Group (VII) elements react by gaining the electrons Fluorine has the smallest atomic radius in this group hence it attracts electrons very strongly hence it gains

- electrons very easily making it to be more reactive. Ease of electron gain decreases down the group.
10. a) Solid CD does not conduct electricity since the ions are not free to move. The ions are held together by electrostatic force of attraction.
 - b) Aqueous CD is a strong electrolyte since the ions are free to move.
 11. a) The outermost electrons in mg and Al are delocalized and free to move hence allow the flow of electric current.
 - b) Alluminium forms a protective coating and prevents further corrosion.
 12. a) "K" and "N" they are in the same group or same number of valency electron/or they loose two electrons.
 - b) L_2O
 - c) "L" it has 7 electrons in its outermost energy level/ react by gaining one electron. Its ionic radius is bigger than atomic radius.
 - d) M; It has highest tendency to loose electrons.
 - e) The ions of "N" have many protons in its nucleus compared to M. The protons in N nucleus pulls the electrons very close to its nucleus.
 - f) "L" gains electrons to form L^- ion, the added electron increases the repulsion/screening effect between electrons in the adjacent energy levels.
 13. a) i) "S" and "W"
 - b) i) "V" it is the only element whose boiling point is below 298 kJ at room temperature.
 - ii) V has stable electron arrangement
 - c) i) $T(NO_3)_3$



d) Ionic or electrovalent bond “T” is a metal while “U” is a non metal, therefore T loses electrons to “U”

e) i) Cathode- Hydrogen gas

ii) Anode – Oxygen gas.

14. a) i) Greenish yellow gas

ii) Slightly soluble

iii) Grey/ black solid.

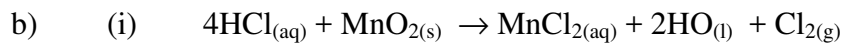

ii) Oxidizing agent. It oxidizes the chloride ions to chlorine gas.

c) i) Iron (iii) Chloride

ii) Mass of chlorine used

$$= 8.06 - 6.30 = 1.76g$$

$$RM\ M\ of\ Cl_2 = 71$$

$$Moles\ of\ Cl_2 = \frac{1.77}{71} = 0.0248\ moles$$

$$71$$

Volume of chlorine

$$= 0.0248 \times 24000 = 595.2\ cm^3$$

d)

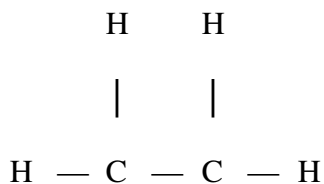

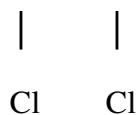

1, 2 – dichloroethane

15. i) “A” It is in group (VI) and gaining two electrons .
- ii) Giant ionic structure: C_2O_3 is an ionic compound. This is a very strong force of attraction (electrostatic force) between the ions.
- iii) “E” is more reactive than H. “E” has a small atomic radii and gains electrons very easily compared to H.
- iv) (I) $\text{B}_{(s)} + \text{Cl}_{2(g)} \rightarrow \text{BCl}_{2(s)}$
- (II) Moles of $\text{Cl}_2 = \frac{1.21}{22.4} = 0.054$ moles
- Moles of B = 0.054 moles
- RAM of $\text{B} = \frac{1.3}{0.054} = 24$
- v) “G” has a small atomic radius compared to F. G has many protons and hence attracts electrons very easily to its nucleus.
- b) i) The oxide of B is alkaline in nature with a PH greater than (8.0).
B is a metal and forms basic oxide. D is a non metal and forms acidic oxide with a PH less than 5.0
- ii) i) I U
II W
- ii) I X

II Y

16. i) Potassium – sodium – Lithium
ii) Lithium has a small atomic radius compared to the others. The outermost electrons are attracted very strongly by the nucleus charges.

A lot of energy is required to pull out the outer most electrons. Atomic radius decreases from potassium to lithium.

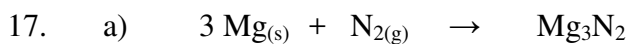

Moles of magnesium = $\frac{8}{24} = 0.333$ moles

24

Moles of $\text{N}_2 = \frac{0.333}{3} = 0.111$ moles

3

Volume of $\text{N}_2 = 0.111 \times 22.4 = 2.488 \text{dm}^3$

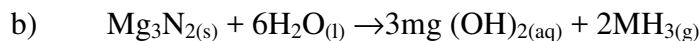

Moles of $\text{Mg}_3\text{N}_2 = 0.111$ moles

Moles of $\text{NH}_3 = 0.111 \times 2 = 0.222$ moles.

Volume of $\text{NH}_3 = 0.222 \times 22.4 = 4.97 \text{dm}^3$

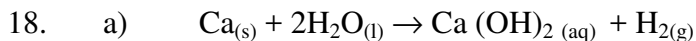

b) Moles of Ca = $\frac{2}{40} = 0.05$ moles

40

Moles of $\text{H}_2 = 0.05$ moles

Volume of $\text{H}_2 = 0.05 \times 24000 = 1,200 \text{cm}^3$

c) $\text{Ca}(\text{OH})_2$ is slightly soluble in water

- d) Sodium reacts with water very vigorously. Reaction may end being explosive since sodium is very reactive.
- e) $2\text{H}_2(\text{g}) + \text{O}_2(\text{g}) \rightarrow 2\text{H}_2\text{O}$
 Moles of $\text{H}_2 = 0.05$ moles
 Moles of $\text{H}_2\text{O} \equiv 0.05$ moles
 RMM of $\text{H}_2\text{O} = 18$
 Mass of $\text{H}_2 = 0.005 \times 18 = 0.9\text{g}$
- f) Calcium is a metal and the outer most electrons are delocalized/ free to move.
19. a) “W” it has the largest atomic radius. The outermost electrons are loosely held by the nucleus. Less energy is required to remove this electron.
- b) $\text{V} + \text{X} \rightarrow \text{V} + \text{X}$
 $\text{V} + \text{Na} \rightarrow \text{NaV}$
20. $2\text{Mg}_{(\text{s})} + \text{N}_{2(\text{g})} \rightarrow 2\text{MgO}_{(\text{s})}$
 $3\text{Mg}_{(\text{s})} + \text{N}_{2(\text{g})} \rightarrow \text{Mg}_3\text{N}_{2(\text{s})}$
21. a) Grey precipitate of iodine will be observed. Chlorine is more reactive than iodine and it displaces it from its solution of sodium iodide.
 $\text{Cl}_{2(\text{s})} + 2\text{I}_{(\text{aq})} \rightarrow \text{I}_{2(\text{s})} + 2\text{Cl}_{(\text{aq})}$
- (b) Covalent bond both chlorine and iodine are non metals and react by sharing electrons.
22. Elements in group (VIII) which have a big atomic radius can react under special condition by losing electrons e.g xenon and fluorine- can react to give xenon hexafluoride

23. i) Reddish brown liquid
- ii) No change
- iii) Chlorine is more reactive than bromine and can displace it from its salts solution, but chlorine can not displace itself.
24. The group (VIII) element reacts by gaining electrons. The atomic radius decreases down the group. Atoms with small ionic radius gain electrons very easily. Hence gain electrons (electro negativity) decreases with an increase in atomic radius.

TOPIC 3

STRUCTURES AND BONDING

1. M: Metallic bonding

N: ionic/ electrovalent bonding

2. i) NH_3

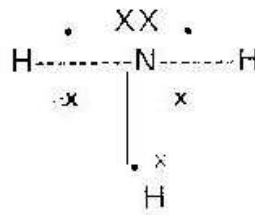
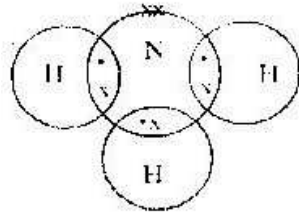

ii) NH_4

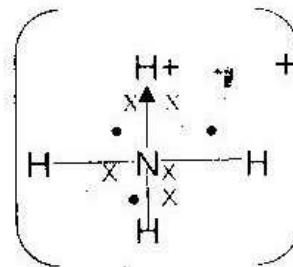
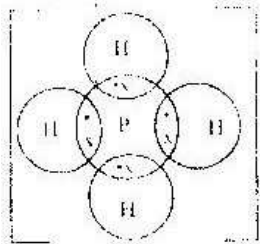

b) NH_3 possesses one pair of electrons which can be shared with H^+ ion which has no electrons to be stable.

3. Anhydrous aluminum chloride is a covalent compound while magnesium chloride is an ionic compound.

4. CO_2

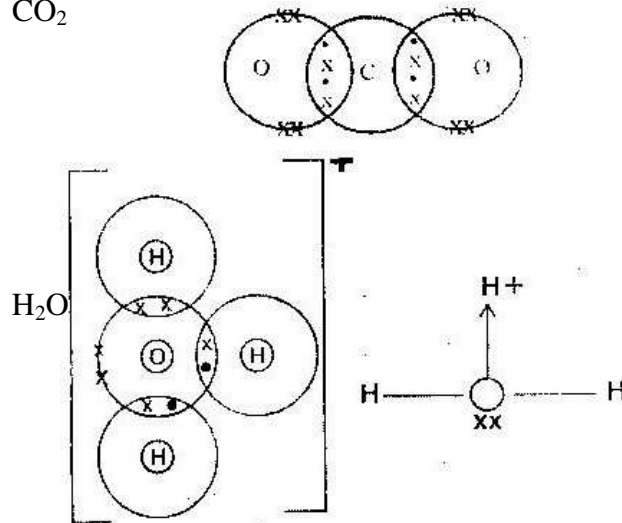

5. a) D b) E

6. a) In a diamond all the carbon atoms are joined together by strong covalent bonds, a three dimensional structure and therefore it is very hard.

b) The carbon graphite atoms are bonded in layers. The layers are held together by weak van der waals forces of attraction. The layers therefore slide over each other very easily.

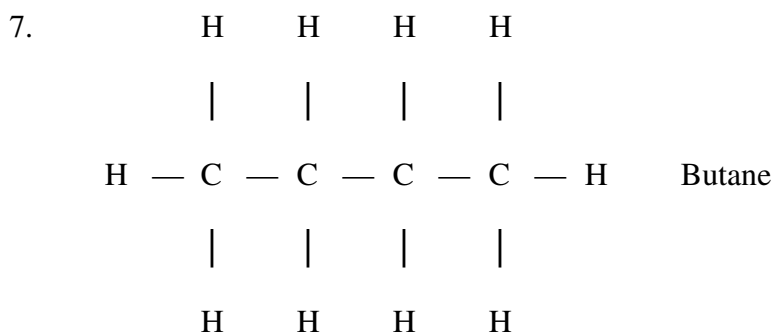

8. Ionic bond. It involves electrons transfer.
9. $\text{HCl}_{(g)}$ is covalent, it dissolves in methyl benzene but does not ionize. Addition of water causes $\text{HCl}_{(g)}$ to ionize since it is polar. H^+ ions are liberated which react with carbonate to produce CO_2
10. In solution, molten or fused since the ions are free.
11. PCl_3 has a simple molecular structure. Molecules are held together by weak van der Waals forces. MgCl_2 has giant ionic structure. Ions are held together by strong electrostatic force of attraction/strong ionic bond.
12. Neon is inert and will prevent oxidation of the filaments.
13. Covalent bond exists between two iodine atoms in an iodine molecule. It involves sharing of the electrons. Van der Waals forces exist between two or more molecules of iodine. It is a weak force while covalent is a strong bond.
14. I. Conduct
II. Ionic
III. Covalent
15. a) The amount of heat absorbed by a mole of substance to change from liquid state to gaseous state without changing the temperature of the surrounding
b) Boiling points increase with increase in molecular mass or increase in number of carbon atoms.

16 a)

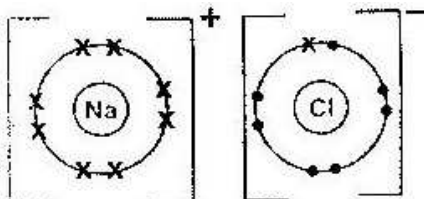

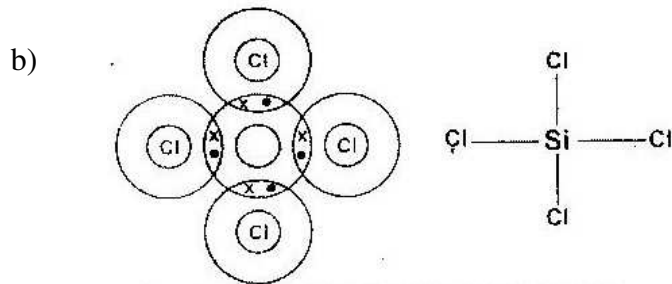

17. Each carbon atom is bonded to other atom by covalent bond to form hexagonal layers. The layers are held together by weak van der waals forces. The layers can slide over each other easily.

18 a) Covalent bond involves sharing of electrons between two or more atoms. Each atom contributes equal number of electrons to be share. In co-ordinate bonding, the shared electrons are contributed by one partical in a molecule. The products of covalent bonding are neutral molecules but in co-ordinate bonding by the products are charged.

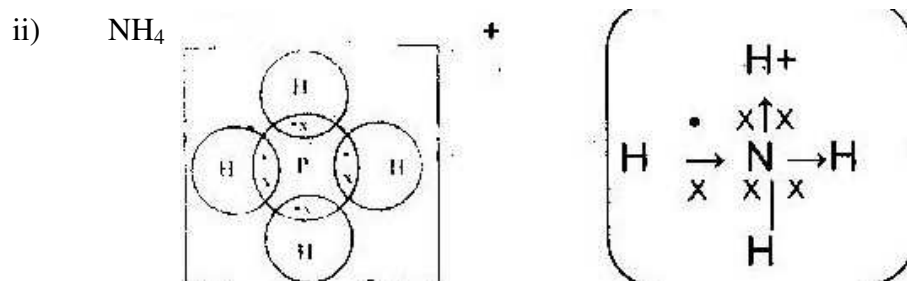

b) or

19. Ethanol is a polar molecule; two forces van der Waals and hydrogen bonding holds the molecules together. Hexane is non-polar and only weak van der Waals forces hold these molecules together.
20. a) Group (VII) elements
b) Chlorine molecule is smaller and the strength of van der Waals forces between molecules of chlorine is weak as compared to iodine.
21. a) Metallic bonding
b) "C" it can gain electrons very easily since it has a small atomic radius. It is very electronegative.
22. a) Ionic bonding/ Electrovalent bond
b) "C" it can gain electrons very easily since it has a small atomic radius. It is very electronegative.
23. a) M 2:8
C 2:8:8
b) i) C ii) N and C
c) Period 4
d) "R" has a large atomic radius than "L". The outermost electrons in "R" are not held tightly to its nucleus.

e)

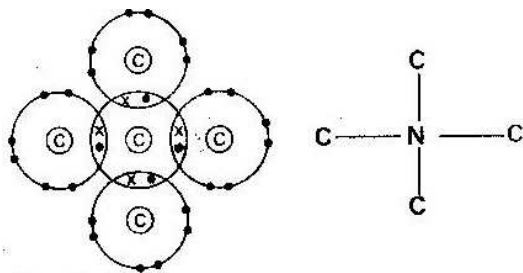

24. i) M= Graphite

N = Diamond

ii) Jewellery: drilling rocks, glass cutters

iii) M/Graphite, the fourth electron is delocalized – in each carbon atom

25 a) i)

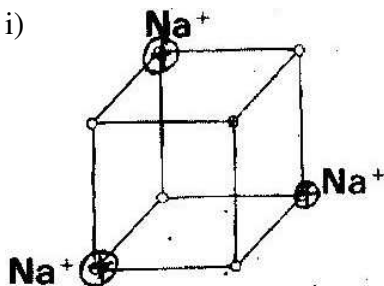

ii) The ions are not free at 25°C since the salt is in solid state but between 80°C and 1413°C the ions are free since electrostatic forces between the ions is overcome.

b) Ammonia reacts with water to form ammonia solution.

c) Dative/co-ordinate bond

26. (i) period "2" it has two energy levels.
- (ii) I. Across the period atomic radius decreases. In A_2 there is more positive nuclear charge than in A_1 hence electrons are more pulled to the nuclear hence reduced size.
- III. A_4 reacts by gaining electrons. Then added electrons increases the repulsion effect between the energy levels.

(iii)

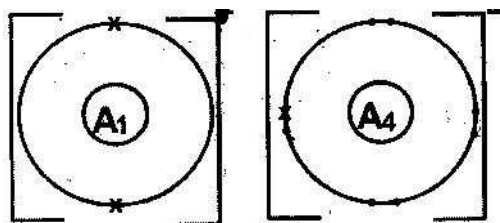

27. The energy used in bond breaking is higher than energy released when new bonds are formed.
28. Water is a polar compound, two forces i.e van der waals forces and hydrogen bond held the molecules of water together. Hydrogen sulphide molecule is non polar and the molecules are held together by weak van der waals forces.
- 29.

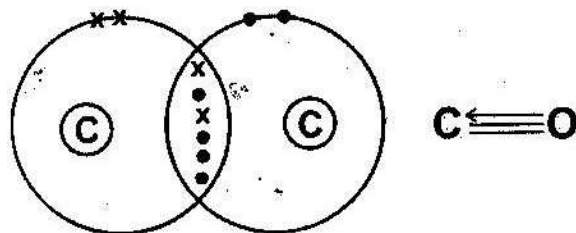

30. i) Electrons are transferred
ii) Electrons are shared equally
31. i) sodium metal atoms has delocalized electrons in its outermost energy level. No ions in sodium solid metal
ii) Iodine is a covalent substance, no free electrons or ions.
iii) Sodium solid iodide has no free ions in solid state but when in solution the ions are free.
32. Giant ionic structure: The compounds contain ions which are held together by strong electrostatic forces of attraction.
33. a) CaCl_2 : It has high melting point and requires a lot of energy to vaporize it.
b) Simple molecular structure
c) Ethanoal is polar with two forces van der Waals and hydrogen bonds holding the molecules. Carbon disulphide is non polar, only van der waals forces holds its molecules together.
34. a) i) U: conduct both in solid and liquid state
ii) W
b) i) V (ii) Y
35. The molecule of methane is small hence the van der waals forces between molecule is weak. Hexane molecule is bulky with strong van der waals forces between molecules.
36. a) G (b) E

TOPIC 4

SALTS

- 19°C to 19.5 °C
 - Place 80g of KNO₃ in 100g of water and heat up to 50°C.
 - All the solid would dissolve because the solubility of calcium ethanoate increases with decrease in temperature.
- W: Because its solubility decreases with increases in temperature.
- Dissolve K₂SO₄ in water; dissolve pbCO_{3(s)} in nitric acid. Mix the two solution and filter to remove solid PbSO₄
- Add water to the solid mixture and stir. “A” ddissolves while “B” does not. Filter the mixture and evaporate to dryness.
- Dilute Nitric acid
 - Lead (II) Sulphate (PbSO₄)
 - $\text{Pb (OH)}_{2(s)} + 2\text{OH}^{-}_{(aq)} \rightarrow \text{Pb(OH)}_{4}^{-2}_{(aq)}$
- Crystals will be formed. This is because the solubility of this substance decreases with increase in temperature.
- Crystals of KClO₃. Cooling causes crystallization. All solution is not yet saturated in the solution because at 40°C the solution is not yet saturated with KNO₃.
- Potassium chloride
 - Calcium chloride
 - Lead (II) nitrate
- Making baking powder.

- Treatment of stomach acidity
 - Health salts
 - Laxatives
 - Fire extinguishers.
 - Soft drinks
10.
 - a) React MgO with Nitric acid to get $\text{Mg}(\text{NO}_3)_2(\text{aq})$. Add strong alkaline solution e.g KOH / NaOH to precipitate $\text{Mg}(\text{OH})_2$. Filter the mixture to get solid $\text{Mg}(\text{OH})_2$
 - b)
 - In toothpaste
 - Neutralize acid in stomach (anti acid).
 11.
 - a) Cone sulphuric acid
 - b) Cooling the concentrated solution to get crystals
 - c) Anhydrous copper (II) Sulphate.
 12.
 - a)
 - i) Deliquescency
 13. React sodium with water to get sodium hydroxide. Bubbles into this solution excess carbon (IV) oxide to get sodium hydrogen carbonate.
 14. React copper with conc nitric acid to get copper nitrate solution. Heat the solution to dryness. $\text{Cu}(\text{NO}_3)_2$ decompose to give CuO. React CUO with dilute HCl to get CuCl_2 . Filter and concentrate the solution to get crystals.s

15. a) i) Heating

ii)

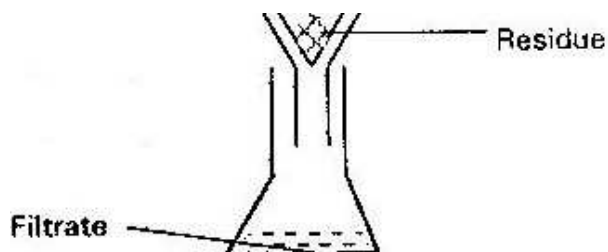

iv) Brown gas/Fumes

v) Addition of anhydrous copper (II) sulphate. It changes from white to blue or odd drops to anhydrous cobalt (II) chloride. It changes from blue to pink.

b) i) One of the salt R is insoluble in water because a residue is formed when water is added.

ii) CO_3^{-2+} it react with acid to give CO_2

iii) Pb^{2+}

c) Zinc nitrate and lead carbonate.

16. a) i) Hygroscopy/ hygroscopic

ii) Deliquescence

iii) Efflorescence

b) i) $\text{Zn}(\text{OH})_4^{-2}$

ii) $\text{Cu}(\text{NH}_3)_4^{+2}$

c)	i)	Fe	S	O	H ₂ O
		<u>20</u>	<u>11.5</u>	<u>23.0</u>	<u>45.3</u>
		56	32	16	18
		<u>0.36</u>	<u>0.36</u>	<u>1.44</u>	<u>2.52</u>
		0.36	0.36	0.36	0.36
		1	1	4	7



iii) Moles of salt = $\frac{6.95}{278} = 0.025$ moles

$$278$$

$$\text{Conc in moles /dm}^3 = \frac{0.025 \times 1000}{250} = 0.1 \text{ M}$$

$$250$$

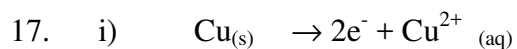

ii) $Q = It = 0.2 \times 5 \times 60 \times 60 = 3,600 \text{ c}$

$$\text{Loss in mass Cu} = \frac{3600 \times 64}{965000} = 1.19\text{g}$$

$$965000 \times 2$$

18. i)

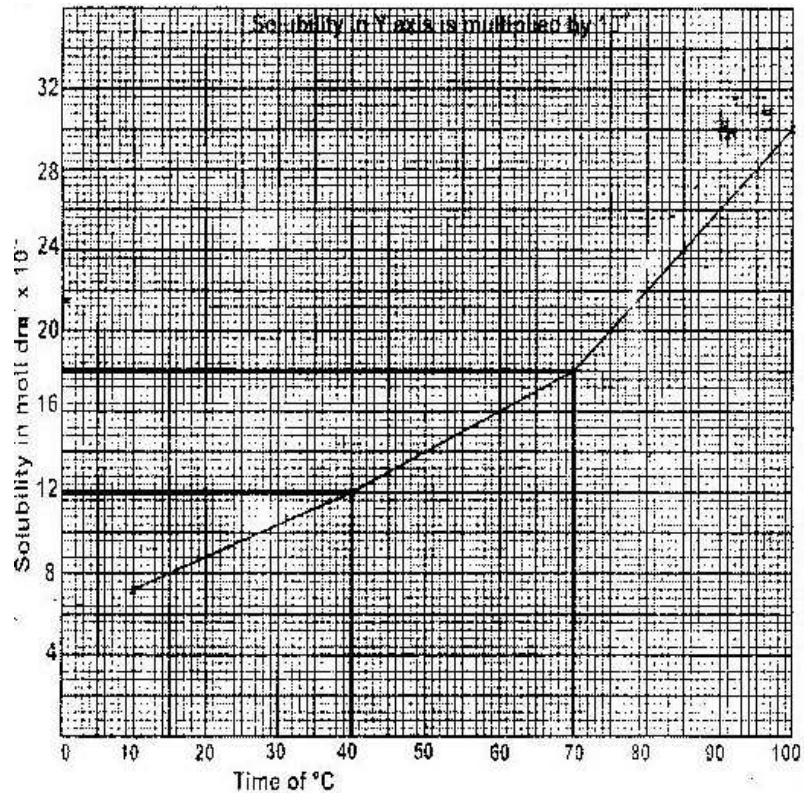

ii) Moles of CuSO_4 deposited = $(0.185 - 0.12) = 0.065$

Mass of $\text{CuSO}_4 \cdot 5\text{H}_2\text{O}$: RMM = 250

= $0.065 \times 250 = 16.25$

b) i) Moles of AgNO_3 in 250cm^3 of solution

= $\frac{0.1 \times 24.1}{1000} = 0.0241$ moles

1000

ii) Moles of NaCl in 25cm^3

Mole ratio 1:1

= 0.00241 moles.

iii) Moles of sodium chloride in 250cm^3

= $\frac{0.00241 \times 250}{25} = 0.0241$ moles

25

iv) RMM of $\text{NaCl} = 58.5$

Mass = $0.0241 \times 58.5 = 1.41$

v) Mass of $\text{H}_2\text{O} = 5.35 - 1.41 = 3.94\text{g}$

vi) 3.94g of water contain 1.41g of NaCl 100g of water contain

$\frac{1.4 \times 100}{3.94} = 35.79\text{g}$

3.94

19. a) Solution which cannot dissolve any more solute at a particular temperature

b) i)

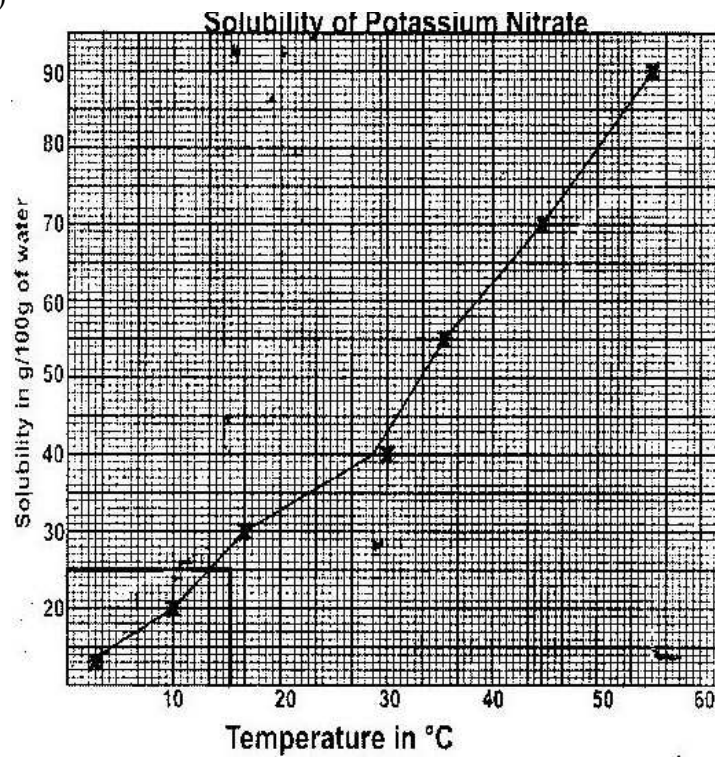

ii) I) 25g/100g of water

II) Mass dissolved = 62g

Mass undissolved = $80 - 62 = 18\text{g}$

20. a) i)

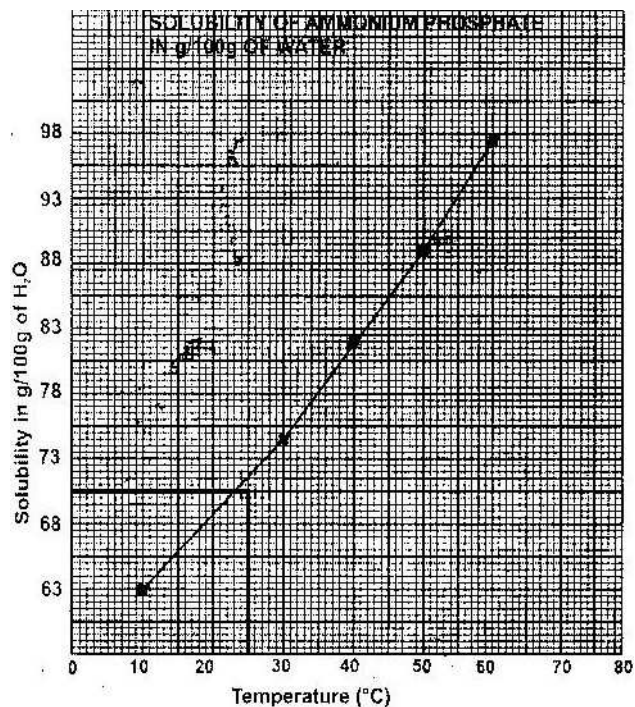

ii) 71g/100g of water.

iii) I. A solution which has dissolved a lot of solute till it can dissolve no more.

II. Mass of solution at 25^oC = 100 + 71 = 171g

$$\text{Mass in (g)} = \frac{100 \times 71}{100} = 71 \text{ (g)}$$

171

21. a) i) $\text{Zn}^{2+}_{(\text{aq})}$

ii) $\text{Zn(OH)}_{2(\text{s})}$

b) It is amphoteric

22. a) i) Iron (II) Sulfide

ii) Hydrogen Sulphide

- b) Darker paper soaked in lead acetate
23. a) BaSO_3
- b) $2\text{HCl}_{(\text{aq})} + \text{BaSO}_{3(\text{s})} \rightarrow \text{BaCl}_{2(\text{aq})} + \text{SO}_{2(\text{g})} + \text{H}_2\text{O}_{(\text{l})}$
24. a) $\text{Pb}^{2+}_{(\text{aq})} + \text{SO}_4^{-2}_{(\text{aq})} \rightarrow \text{PbSO}_{4(\text{s})}$

Moles of Pb^{2+} salts $\equiv \underline{0.63} = 0.003$ moles

207

RAM of $\text{PbSO}_4 = 303$

Mass of $\text{PbSO}_4 = 303 \times 0.003 = 0.91\text{g}$.

25. a) $\text{Fe}^{3+}_{(\text{aq})}$
- b) Oxidizing agent
- c) $2\text{Fe}(\text{OH})_{3(\text{s})} \xrightarrow{\text{heat}} \text{Fe}_2\text{O}_{3(\text{s})} + 3\text{H}_2\text{O}_{(\text{l})}$
26. a) Zn
- b) $\text{Zn}(\text{NH}_3)_2$

27. Dissolve lead carbonate in dilute nitric acid. React the mixture with dilute hydrochloric acid. Filter to get lead (II) chloride.

28. Sodium hydroxide is deliquescent. It absorbs water vapour from atmosphere and dissolves the solution formed (NaOH) absorbs CO_2 to form Na_2CO_3 and H_2O . H_2O evaporate to leave a white solid of Na_2CO_3 .

29. Colour change from blue to white powder. Vapour which changes anhydrous cobalt chloride from blue to pink produced.

30. a) Brown precipitate of iron (III) hydroxide. Chlorine Fe^{3+} to Fe^{3+} ions.

- b) It will dissolve to form a clear solution. Ammonia reacts with silver chloride to give a complex salt.

TOPIC 5

CARBON AND SOME OF ITS COMPOUNDS

- Dense than air
- Does not burn
- Put off burning flame
- Ca(OH)_2 produces CaCO_3 which is insoluble . NaOH forms Na_2CO_3 which is soluble.
- SO_2 ; It is an acidic gas and react with Ca (OH)_2 which is basic.
- Equilibrium shift to the left to reduce the pressure.
- Add water and stir. Sodium carbonate will dissolve. Filter to get lead carbonate as a residue.
- Kerosene is less dense and float spreading the fire. CO_2 is more dense and covers the fire preventing oxygen reaching the fire.
- K^+ / Na^+ and CO_3^{-2}
- $\text{C}_{(s)} + \text{O}_{2(s)} \longrightarrow \text{CO}_{2(g)}$
 - $\text{CO}_{2(g)} + \text{C}_{(s)} \longrightarrow 2\text{CO}_{(s)}$
- $\text{PbO}_{(s)} + \text{CO}_{(s)} \longrightarrow \text{Pb}_{(s)} + \text{CO}_{2(g)}$
 - Colour of PbO change from yellow when cold, brown when hot, Finally grey.
 - Hydrogen gas
- ammonia gas
 - Filtration/precipitation/crystallization
 - $2\text{NaHCO}_{3(s)} \longrightarrow \text{Na}_2\text{CO}_{3(s)} + \text{CO}_{2(g)} + \text{H}_2\text{O}_{(l)}$

11. a) $H = CaCO_3$
 $J = CaO$
- b) - Fertilizer/for liming/ making motar
 - Rising soil PH
12. **Luminous** **Non luminous**
- Sooty flame Non-sooty
- Produce more light Less light
- Less heat very hot
- Weavy flame Stead flame
13. a) colour of solid change from black to reddish brown.
- b) $CuO_{(s)} + CO_{(g)} \rightarrow Cu_{(s)} + CO_{2(g)}$
- c) CO is poisonous gas
14. a) $CO_{2(g)} + Ca(OH)_{2(aq)} \rightarrow CaCO_{3(s)} + H_2O_{(l)}$
- b) White precipitate dissolves because $Ca(HCO_3)_2$ formed is soluble
15. Moles of Hcl = $\frac{20}{1000} = 0.02$ moles
- Moles of $GCO_3 \equiv \frac{1}{0.01} = 100$
- RAM of G = $100 - 60 = 40$
16. a) To reduce PbO to Pb
- b) To remove silica as slag
- c) To reduce unreacted PbO to Pb
17. Equilibrium shift to the right to replace CO_2 which is removed.

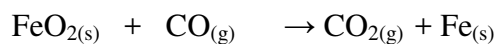
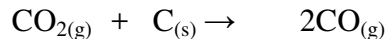
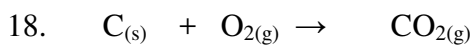

19. a) Reduction; Oxygen is removed

b) Oxygen is removed/ oxidation state of Pb change from +2 to 0.

c) Ammonia gas/ Hydrogen gas

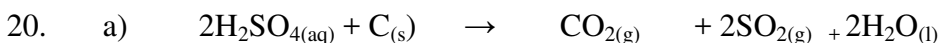

b) Oxidation No: of S in SO_2

$$+2 + S + 8 = 0$$

$$S = + 8 - 2 = +6$$

Oxidation No: of S in SO_2

$$SO_2 = 0$$

$$S + -4 = 0$$

$$S = -+4$$

Change in oxidation from + 6 \rightarrow +4 (reduction)

21. Sublimation

22. a) Cone: Sulphuric acid and Ethanoic acid.

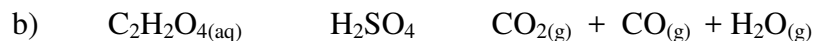

c) It is colourless and odourless.

23. a) Carbon (IV)Oxide

b) Blue flame, carbon (II) oxide is burning

24. It is more dense than air

It will react with calcium oxide since CO_2 is acidic and CaO is basic.

- iii) Add H_2SO_4 , add $\text{NaSO}_4/\text{K}_2\text{SO}_4$ filter to obtain CaSO_4 as a residue. Heat the residue to dryness.
30. a) i) Allotropes
- ii) Add salt to methylbenzene, fullerene dissolves. Filter the mixture to remove the residue. Heat the filtrate to make it concentrated cool the solution slowly to get crystals
- iii) $12n = 720$: $n = \frac{720}{12} = 60$

12

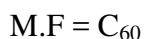

31. Petrol is less dense float and spread fire

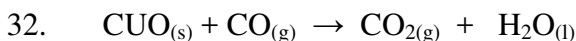

33. a) i) - Decomposition of CaCO_3 in S

- Filtration

ii) - Drying agent



c) Making baking powder.



ii) Moles of $\text{CO}_2 = \frac{672}{22400} = 0.03$

22400

Moles of HCl = $0.03 \times 2 = 0.006$ moles

Conc of HCL = $\frac{0.006 \times 1000}{1} = 1.0$ m

30

Value of x moles of $\text{Na}_2\text{CO}_3 \equiv 0.03$

$$X(\text{mass}) = \frac{0.006 \times 1000}{30} = 1.0$$

30

iii) Value of x moles of $\text{Na}_2\text{CO}_3 = 106$

RMM of $\text{Na}_2\text{CO}_3 = 106$

$$X(\text{mass}) = 0.03 \times 106 = 3.18\text{g}$$

34. a) Hardness caused by soluble Ca^{2+} + Mg^{2+}

HCO_3^- salts can be removed by warming.

b) Hardness caused by soluble CaSO_4 cannot be removed by warming.

i)

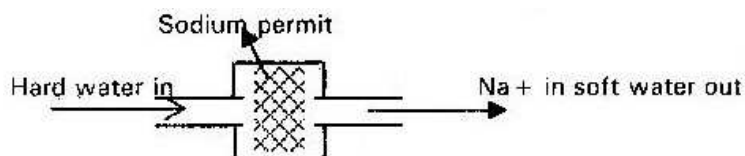

ii) Contain $\text{Ca}^{2+}_{(\text{aq})} + \text{Na}^+_{\text{p}(\text{s})} \rightarrow \text{Na}^+_{(\text{aq})} + \text{Ca}^{2+}_{\text{p}(\text{s})}$

35. CuCO_3



36. i) Burns with blue flame to give a gas which form white ppt with lime water.

ii) Forms white ppt with lime water.

37. Forms a coat of CaSO_4 which prevent further reaction CaCl_2 is soluble.

38. i) Combustion/ decay

ii) Photosynthesis/ marine animals/ dissolve in water.

39.	C	H	O
	<u>40</u>	<u>6.67</u>	<u>46.67</u>
	12	1	16
	3.33	6.67	2.91
	3.33	3.33	3.33
	1	2	1
			CH ₂ O

40. i) N = CO₂
- ii) N is slightly soluble in water.
- PH decreases/ acidic NO₂ dissolves in water to form HNO₂.

FORM THREE WORK

TOPIC 1

GAS LAWS

1. Kinetic energy of the gas increases, and gas molecules moves faster. The space between them increases.
2. "Q" it diffuses more slowly i.e, it covered a short distance
3. Hydrogen; it is less dense than Co₂ and diffuses faster
4. Air is less dense than carbon (IV) oxide and so it enters the porous pot faster than carbon (IV) oxide and so it enters the porous pot faster than carbon (IV) oxide leave out of it.

This creates a high pressure in the pot and the level of water rises up as shown.

5. $\frac{V_1}{T_1} = \frac{V_2}{T_2}$

$$T_1 \quad T_2$$

$$\therefore V_2 = \frac{V_1 T_2}{T_1}$$

$$T_1$$

$$\therefore T_2 = \frac{250 \times 315}{300} = 262.5 \text{ cm}^3$$

$$300$$

6. $\frac{P_1 V_1}{T_1} = \frac{P_2 V_2}{T_2} \therefore T_2 = \frac{T_1 P_2 V_2}{P_1 V_1}$

$$T_1 \quad T_2 \quad P_1 V_1$$

$$\therefore T_2 = \frac{500 \times 0.5 \times 100}{1 \times 400} = 62.5 \text{K}$$

$$1 \times 400$$

7. $\frac{P_1}{T_1} = \frac{P_2}{T_2} \therefore P_2 = \frac{P_1 T_2}{T_1}$

$$T1 \quad T2 \quad T1$$

$$\therefore P2 = \frac{760 \times 373}{273} = 1038.39 \text{ mmHg}$$

$$273$$

8. Rmm of $O_3 = 16 \times 3 = 48$

Rmm of $CO_2 = 12 + 36 = 44$

$$\frac{T_{CO_2}}{96} = \frac{\sqrt{44}}{\sqrt{48}}$$

$$96 \quad \sqrt{48}$$

$$T_{CO_2} = \frac{96 \times 6.63}{6.92} = 91.9 \text{ seconds}$$

$$6.92$$

9. The entire solution turns pink/purple.

- potassium permanganate/potassium manganate (VII) particles diffused into the water molecules.

10. a) The volume of a fixed mass of gas is inversely proportional to the pressure at constant temperature.

b) $P1V1 = P2V2$

$$\therefore V2 = \frac{P1V1}{P2}: V2 = \frac{3 \times 1}{2} = 1.5 \text{ lts}$$

$$P2$$

$$2$$

11. Mass due to C = $12 \times 4.2 = 1.145_{(g)}$

Mass due to H = $\underline{2} \times 1.171 = 0.1899$

18

Elements	C	H
Mass	<u>1.145</u>	<u>0.1899</u>
Ram	12	1
Moles		
Mole ratio	1	2

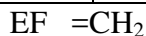

12. $TO_2 = \frac{\sqrt{RMM O_2}}{\sqrt{RMM SO_2}}$

$\sqrt{RMM SO_2}$

$\therefore TSO_2 = \frac{50 \times \sqrt{64}}{\sqrt{32}} = TO_2 \times 70.7 \text{ seconds}$

$\sqrt{32}$

13. a) The volume of a fixed mass of gas is directly proportional to its temperature in Kelvin.

b) $\frac{P_1 V_1}{T_1} = \frac{P_2 V_2}{T_2}$

$T_1 \quad T_2$

$T_2 = \frac{291 \times (1.0 \times 10^5) \times 2.8 \times 10^{-2}}{(1.0 \times 10^5) \times (3.5 \times 10^{-2})} = 2328k$

$(1.0 \times 10^5) \times (3.5 \times 10^{-2})$

14. Purple/ pink particles spread to form a uniform solution; particles of water have k.e they collide and disintegrate the particles of $KMNO_4$. Diffusion takes place.

15. a) rate of diffusion is directly proportional to the square root of the density.

b) $\frac{R_{ow}}{R_{om}} = \frac{\sqrt{RMM X}}{\sqrt{RMM A}} = \frac{12}{1} = \frac{\sqrt{RMM X}}{\sqrt{RMM A}}$

$$ROX \quad \sqrt{RMMO_2} \quad X \quad \sqrt{16}$$

$$X = \frac{12 \times 4}{6.633} = 7.2365 \text{cms}^{-1}$$

$$6.633$$

$$16. \quad \underline{TA} = \frac{\sqrt{RMMMA}}{\sqrt{RMMO_2}} \quad \therefore \underline{24} = \frac{\sqrt{RMMMA}}{\sqrt{32}}$$

$$TO_2 \quad \sqrt{RMMO_2} \quad 20 \quad \sqrt{32}$$

$$RMMMA = 46$$

$$17. \quad \underline{TCO_2} = \frac{\sqrt{RMMCO_2}}{\sqrt{RMMCCL}} \quad \therefore \underline{200} = \frac{\sqrt{44}}{\sqrt{36.5}}$$

$$THCL \quad \sqrt{RMMCCL} \quad THCL \quad \sqrt{36.5}$$

$$\therefore THCL = 36.5 \times 200 = 18.2 \text{ 158 secs}$$

$$18. \quad \text{Moles of CO} + 2+ = \underline{11} = 0.25 \text{ moles}$$

$$44$$

$$\text{Moles of butane} = 2 \times 0.25 = 0.0625 \text{ moles}$$

$$\text{Volume of butane} = 0.0625 \times 24 = 1.5 \text{ litres}$$

19. P is less dense than air, so it diffuses into the porous pot fast compared to the rate at which air moves out of the pot. This increases the pressure in the porous pot and water rises as shown. Q is more dense than air, hence a lot of air diffuses out of the porous pot compared to the amount of Q moving in. This reduces the pressure inside the porous pot and atmospheric pressure forces water to vacuum left in the porous pot.

20. i) White deposit/ white solid/white fumes
- ii) Position of formation; Nearer the HCl side since NH_3 is less dense and diffuses faster compared to HCl
- iii) $\text{NH}_3(\text{g}) + \text{HCl}(\text{g}) \rightarrow \text{NH}_4\text{Cl}(\text{s})$

21. $\text{Rate "K"} = \frac{\sqrt{RMMH_2}}{\sqrt{RMM K}}$

$\text{Rate } +H_2 = \frac{\sqrt{RMMH_2}}{\sqrt{RMM K}}$

$\text{Rate of K} = \frac{88}{40} = 2.2 \text{ cm}^3/\text{sec}$

40

$\text{Rate } H_2 = 50 = 10 \text{ cm}^3/\text{sec}$

$RMM K = \frac{10 \times \sqrt{2}}{2.2}$

2.2

$RMM 'K' = \frac{2 \times 100}{(2.2)^2} = 41.322$

$(2.2)^2$

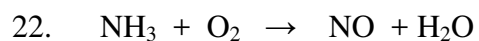

Vol: 300 250 200 300

Ratio : 4: 5: 4: 6:

Equation:

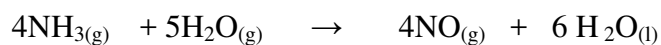

23.

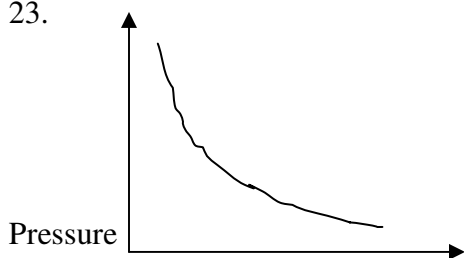

Volume

$$24. \quad \frac{V_1}{T_1} = \frac{V_2}{T_2} \quad \therefore T_2 = \frac{V_2 T_1}{V_1}$$

$$T_2 = \frac{300 \times 298(\text{k})}{200} = 447\text{k}$$

$$25. \quad \frac{P_1 V_1}{T_1} = \frac{P_2 V_2}{T_2}$$

But $P_1 = P_2$

$$\frac{V_1}{T_1} = \frac{V_2}{T_2} \quad \therefore V_2 = \frac{V_1 \times T_2}{T_1}$$

$$V_2 = \frac{200 \times 243}{298} = 196.6\text{cm}^3$$

$$26. \quad \frac{V_1}{T_1} = \frac{V_2}{T_2} \quad \therefore T_2 = \frac{V_2 T_1}{V_1}$$

$$T_2 = \frac{160 \times 298}{2000} = 238.4\text{k}$$

$$\text{Temp in } ^\circ\text{C} = 238.4 - 273 = -34.6^\circ\text{C}$$

$$27. \quad \frac{P_1 V_1}{T_1} = \frac{P_2 V_2}{T_2} \quad \therefore T_2 = \frac{P_2 V_2}{P_1 V_1}$$

$$T_2 = \frac{800 \times 190 \times 301\text{k}}{760 \times 330} = 1.82.4\text{k}$$

TOPIC 2

THE MOLES FORMULAE AND CHEMICAL EQUATIONS

1. Mass of $H_2O = 34.8 - 15.9 = 18.9 \text{ g}$

Components	Na_2CO_3 :	X H_2O
Mass	15.9g	18.9g
Rmm	106	18
Moles	15.9	18.9
	106	18
Moles	15.9	18.9
	106	18
	0.15	1
Ratio	1	: 7

$X = 7$

2. 2 moles of H_2 react with 1 mole of O_2

$\therefore 100\text{cm}^3$ of H_2 will react with 50cm^3 of O_2

$\therefore O_2$ is in excess by 50cm^3

3. 1 mole of $CaCO_3$ react with 2 mole of HCl

$\therefore 0.1$ mole $CaCO_3$ react with 0.2 mole of HCl

Rmm $CaCO_3 = 40 + 12 + 48 = 100$

Moles of $CaCO_3 = \frac{15}{100} = 0.15$ moles

100

Excess moles of $CaCO_3 = 0.15 - 0.1 = 0.05$ moles

Excess mass of $CaCO_3 = 0.05 \times 100 = 5\text{g}$

4. a) $(C_3H_6O)_n = 116$
 $(3 \times 12) + (6 \times 1) + 16) n = 116$

$58n = 116: n = 2$

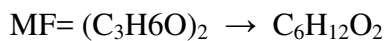

b) $\frac{12 \times 6 \times 100}{116} = 62.07\%$

116

5. a) $H_2S(g)$:- It adds (H) to Cl_2 and reduce it to HCl . or the oxidation number of Cl_2 reduced from 0 to -1

b) Theoretical yield of $H_2S = \frac{100}{75} \times 2.4 = 3.2g$

75

Moles of $H_2S =$ moles of S: $\frac{3.2}{32} = 0.1$ moles

32

6. i) $(C_2H_3)_n = 54$

$27n = 54$

$n = 2 : MF = (C_2H_3)_2 - C_4H_6$

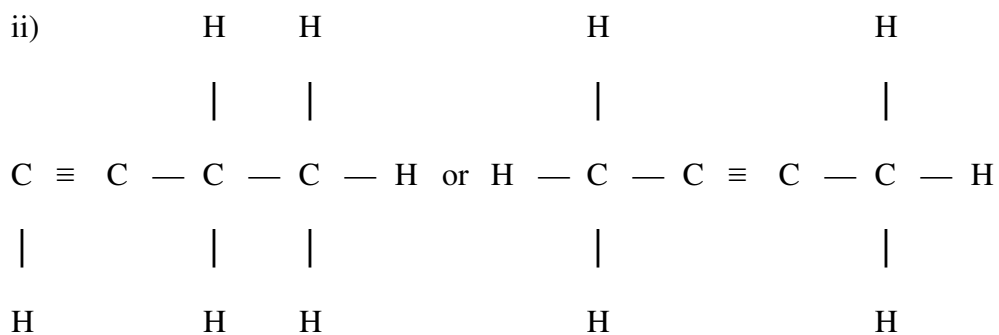

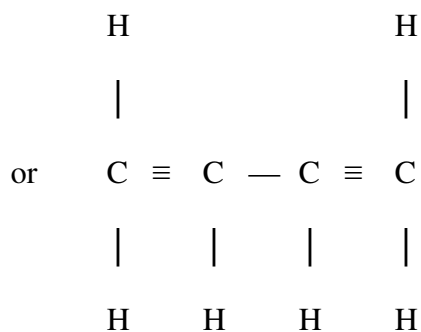

iii) Alkyne if it has $-\text{C} \equiv \text{C}-$ or alkene if it has $-\text{C}=\text{C}-$ depending with structural formula.

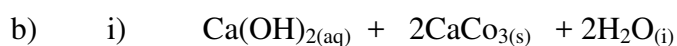

ii) $\frac{90 \times 0.01}{1000} = 0.0009$

c) It will form “scum” initially then produce lather after adding a lot of soap solution. All the Ca^{2+} ions must be precipitated before soap lathers.

7. Moles of $\text{H}_2 = \frac{10}{2} = 5$ moles

Moles of $\text{NO}_2 = 5$ moles

RMM of $\text{NO}_2 = 46$

5 moles of $\text{NO}_2 = 5 \times 46 = 230\text{g}$

8. Mass of H = $\frac{12}{44} \times 3.52 = 0.96\text{g}$

Mass of H $\frac{2}{18} \times 1.44 = 0.16\text{g}$

Elements	C	H
----------	---	---

Moles	$\frac{0.96}{12} = 0.08$	$\frac{0.16}{1} = 0.16$
-------	--------------------------	-------------------------

12 1

Mole ratio 1 : 2

EF = CH₂

(CH₂)_n = 56: 14n = 56: n = 56 ÷ 14 = 4

14

MF = (CH₂)₄ → C₄H₈

9. Molarity of NaOH = $\frac{4}{40} = 0.1 \text{ mol/dm}^3$

40

Moles of NaOH in 20cm³ = $\frac{0.1 \times 20}{1000} = 0.002$ moles

1000

Mole ratio 2:1

Moles of H₂SO₄ = $\frac{0.002}{2} = 0.001$ moles

2

Molarity of H₂SO₄ = $\frac{0.001 \times 1000}{8} = 0.125 \text{ mol/dm}^3$

8

10. RMM of H₂O = 2 + 16 = 18

RMM Na₂CO₃ = 46 + 12 + 48 = 106

Moles of H₂O = $\frac{14.5}{18} = 0.805$ moles

18

Moles of Na₂CO₃ = $\frac{85.5}{100} = 0.855$

100

Mole ratio 1:1 N = 1: Na₂CO₃: H₂O

11. a) $\text{H}_2\text{SO}_{4(\text{aq})} + 2\text{NaOH}_{(\text{aq})} \rightarrow \text{Na}_2\text{SO}_{2(\text{aq})} + 2\text{H}_2\text{O}_{(\text{l})}$
 b) Blue litmus paper turns red while red litmus remains red
 c) The acid is in excess

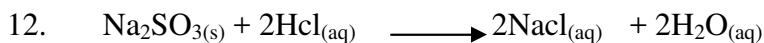

$$\text{Moles of SO}_2 = \frac{960}{2400} = 0.04 \text{ moles}$$

Mole ratio 1:1

$$\text{Moles of Na}_2\text{SO}_3 = 126$$

$$\text{Mass of Na}_2\text{SO}_3 = 0.04 \times 126 = 5.04 \text{ g}$$

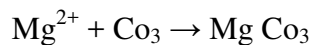

b) $\text{RMM of Mg CO}_3 = 84$

$$\text{Moles of Mg CO}_3 = \frac{8.4}{84} = 0.1 \text{ moles}$$

$$84$$

Mole ratio 1:1

$$\text{Moles of Mg}(\text{NO}_3)_2 \text{ in } x \text{ cm}^3 = 0.1 \text{ moles}$$

$$X = \frac{1000 \times 0.1}{0.5} = 200 \text{ cm}^3$$

$$0.5$$

14. $\text{Moles of HCl} = \frac{20 \times 1}{1000} = 0.02 \text{ moles}$

$$1000$$

$$\text{Moles of GCO}_3 = \frac{0.02}{1} \text{ moles}$$

$$1$$

$$\text{RMM of G} = \frac{1 \times 1}{0.02} = 100$$

0.01

$$G = 100 - 60 = 40 \therefore \text{RAM of G} = 40$$

15. Mass of water = $94.5 - 51.3 = 43.2$

$$\text{RMM of Ba(OH)}_2 = 171; \text{RMM of H}_2\text{O} = 18$$

$$\text{Moles of Ba(OH)}_2 = \frac{51.3}{171} = 0.3$$

171

$$\text{Moles of H}_2\text{O} = \frac{43.2}{18} = 2.4$$

18

Moles of ratio is 1:8

$$n = 8$$



16. Mass in $500\text{cm}^3 = 15 \times 1.05 = 15.75\text{g}$

$$\text{Mass in } 100\text{cm}^3 = 15.75 \times 2 = 31.5\text{g}$$

$$\text{Molarity} = \frac{31.5}{300} = 0.105\text{m}$$

60

17. a)

Elements	C	H	O
%	<u>64.9</u>	<u>21.6</u>	<u>13.5</u>
	12	16	1
Moles	5.41	1.35	13.5
Ratio	4	1	10

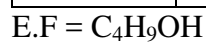

b) H H H H

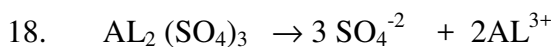
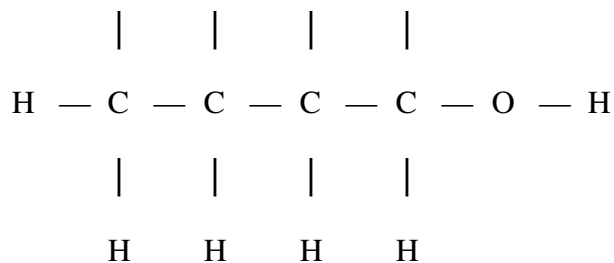

$$\text{Moles of } \text{Al}_2(\text{SO}_4)_3 = \frac{6.84}{342} = 0.02$$

$$342$$

$$\text{Moles of } \text{SO}_4^{-2} = 0.02 \times 3 = 0.06$$

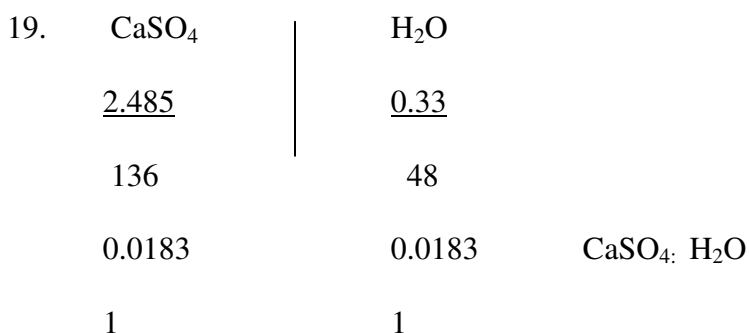

$$310$$

$$\text{Moles of } \text{H}_3\text{PO}_4 = 0.37096 \times 2 = 0.74192$$

$$\text{Mass} = 0.74192 \times 98 = 72.71\text{kg}$$

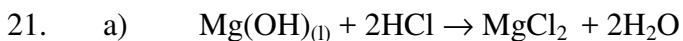

$$\text{Mole of HCl} = \frac{23 \times 0.1}{1000} = 0.0023 \text{ moles}$$

$$1000$$

$$\text{Moles of } \text{Mg}(\text{OH})_2 = \frac{0.0023}{2} = 0.00115$$

$$2$$

$$\text{Mass} = 0.00115 \times 58 = 0.00667\text{g}$$

- b) $\frac{0.00667}{0.5} \times 100 = 13.34\%$
22. a) Brine (sodium Chloride)
- b) i) $2\text{NaOH} + \text{H}_2\text{SO}_4 \rightarrow \text{Na}_2\text{SO}_4 + 2\text{H}_2\text{O}$
- ii) No of moles of $\text{H}_2\text{SO}_4 = \frac{40 \times 0.5}{1000} = 0.02$ mole
- iii) I. 1 mole of NaOH = $0.02 \times 2 = 0.04$ moles
 $\frac{1000}{100} \times 0.04 = 0.4$ moles/dm³
- II. RMM of NaOH in 1 litre = $40 \times 0.4 = 16$ g
 Mass of NaOH in 1 litre = $40 \times 0.4 = 16$ g
 Unreacted substance (NaCl) = $17.6 - 16 = 1.6$ g
23. i)

Elements	Fe:	S:	O:	H ₂ O
% Mass	20:2	11.5	23.0	45.3
RAM	56	32	16	18
Moles	<u>20.2</u>	<u>11.5</u>	<u>23.0</u>	<u>45.3</u>
	56	32	16	18
	0.3607	0.359	1.438	2.5167
Mole ratio	1	1	1	1

Formula $\text{FeSO}_4 : 7\text{H}_2\text{O} = 278$

Molarity = $\frac{\text{g/dm}^3}{\text{Rmm}} = \frac{27.8}{278} = 0.1\text{M}$

Rmm 278

24. $\text{MgCl}_{2(\text{aq})} + 2 \text{AgNO}_{3(\text{aq})} \rightarrow 2\text{AgCl}_{(\text{s})} + \text{mg}(\text{N})_{3(\text{aq})}$

$$\text{Moles of MgCl}_2 = \frac{1.9}{95} = 0.02 \text{ moles}$$

95

$$\text{Moles of AgNO}_3 = 0.02 \times 2 = 0.04 \text{ moles}$$

$$\text{RMM of AgCO}_3 = 170$$

$$\text{Mass of AgNO}_3 = 0.04 \times 170 = 6.8\text{g}$$

25.	Elements	Fe	0
	Mass	8.4	3.6
	RAM	56	16
	Moles	<u>8.4</u>	<u>3.6</u>
		56	16
	Mole ratio	<u>0.15</u>	<u>0.225</u>
		0.15	0.15
		1	: 1.5
	X2	2	: 3

Formular = Fe₂O₃

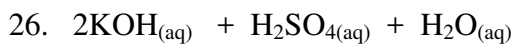

$$\text{Moles of KOH} = \frac{24 \times 0.1}{1000} = 0.0024 \text{ moles}$$

1000

$$\text{Moles of H}_2\text{SO}_4 = \frac{0.0012 \times 100}{30} = 0.04\text{m}$$

30

27. i)

25.0	25.0	25.0
------	------	------

ii) Average $\frac{25.0+25.0}{2} = 25.0\text{cm}^3$

3

iii) a) Moles of acid $\frac{0.1 \times 25}{1000} = 0.0025$ moles

b) Moles of X_2CO_3 $\frac{1 \times 13.8}{0.1} = 138g/dm^3$

iv) Molarity of carbonate = $\frac{0.0025 \times 1000}{25} = 0.1$

v) Formula mass X_2CO_3 $\frac{1 \times 13.8}{0.1} = 138g/dm^3$

vi) $X_2CO_3 = 138$
 $2x + 12 + 48 = 138$
 $X = \frac{138.60}{2} = 69.3$

2

28 i) Mass of iron = $12.66 \times 10.98 = 1.68g$

Mass of oxygen $13.30 - 12.60 = 0.64$

Elements	Fe	O
	<u>1.68</u>	<u>0.64</u>
	56	16
Moles	0.03	0.04
Ratio	3	4

Formula Fe_3O_4



b) Molarity of the acid = $\frac{9.8}{98} = 0.1 \text{ mole/dm}^3$

c) Molarity of carbonate

$$\text{Moles of acid reacting} = \frac{0.1 \times 12.3}{1000} = 0.00123$$

Moles of carbonate reacting = 0.00123 moles by mole ratio 1:1

$$\text{Molarity} = \frac{0.00123 \times 1000}{12.5} = 0.0984 \text{ M}$$

d) Molar mass of the carbonate = $\frac{\text{g/dm}^3}{\text{Molarity}}$

$$= \frac{13.8}{0.0984} = 140$$

e) $\text{M}_2\text{CO}_3 = 140$

$$2\text{M} = 140 - (12 + 48)$$

$$2\text{M} = 80$$

$$\text{M} = \frac{80}{2} = 40$$

$$\text{RAM of "M"} = 40$$

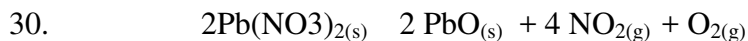

$$\text{RMM Pb} = 223$$

$$\text{Therefore moles of PbO} = \frac{22.3}{223} = 0.1 \text{ moles}$$

$$223$$

$$\text{Moles of Pb}(\text{NO}_3)_2 = 0.1 \text{ mole from mole ratio}$$

$$\text{Rmm Pb}(\text{NO}_3)_2 = 331 \times 0.1 \text{ mole from mole ratio}$$

Rmm Pb(NO₃)₂ = 331

Mass pf Pb(NO₃)₂

Mass of Pb(NO₃)₂ = 331 x 0.1 = 33.1g

31.

i) Average volume of B

$$\frac{24.1 + 24.0 + 24.0}{3} = 24.03\text{cm}$$

ii) Moles of A in 20cm³

$$\text{Molarity} = \frac{48}{40} = 1.2\text{m}$$

$$\text{Therefore moles} = \frac{20 \times 1.2}{1000} = 0.024 \text{ moles}$$

iii) Moles of acid B = $\frac{0.024}{2}$ = 0.012 moles

$$\text{Molarity of B} = \frac{0.012 \times 100}{24.03} = 0.499\text{M}$$

iv) Formula mass of (COO)₂ : nH₂O

$$= \frac{63 \times 1}{0.499} = 126\text{g}$$

v) Value of n

$$(\text{COO})_2 \cdot n\text{H}_2\text{O} = 126$$

$$24 + 64 + 4 + 18n = 126$$

$$n = \frac{126 - 90}{18} = 2$$

$$n = 2$$

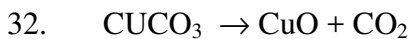

1 mole CuCO_3 gives 1 mole of $\text{CO}_{2(g)}$

1 mole of CO_2 at stp occupies 22.4 dm^3

33. Moles of N_2 gas = $\frac{360}{24000}$

$$= \frac{360}{24000}$$

No: of molecules = $\frac{360}{24000} \times 6.0 \times 10^{23}$

$$= \frac{360}{24000} \times 6.0 \times 10^{23}$$

$$= 9.0 \times 10^{21} \text{ molecules}$$

34. i) Mono atomic gas: These are gases which exist as single independent atoms e.g Helium (He), Neo (Ne) Argon (Ar)
- ii) Diatomic gas: gases which exist as combined atoms where two atoms are combined together to form a molecule e.g oxygen (O_2) Chlorine (Cl_2) Hydrogen (H_2)
- iii) Atomicity of element: number of atoms in one molecule of it e.g zone (O_3) has atomicity of three. The molecule formed is a triatomic or triatomic.

heat is released from reaction.

7. a)

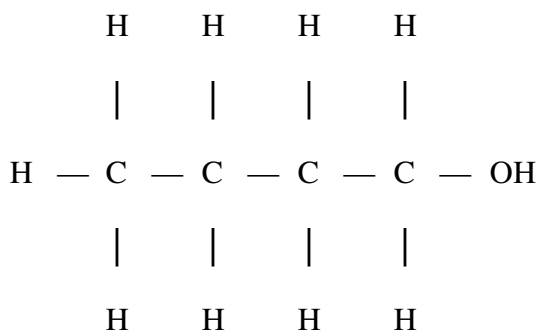

Butanol/Butan-1-ol

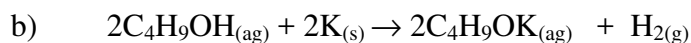

8. Add solid NaHCO_3 to both, CH_3COOH produces effervescence and a colourless gas which give white precipitate with lime water is produce No reaction with $\text{CH}_3\text{CH}_2\text{CH}_2\text{OH}$.

9. Reaction 1: Carbon is oxidized fully to it highest oxidation state in CO_2 .

10. Monomer $\text{CH}_2 = \text{CH}$

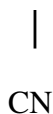

$$\text{Rmm of monomer} = (12 \times 3) + 1 \times 3 + 1 \times 14 = 53$$

$$53n = 5194$$

$$n = \frac{5194}{53} = 98$$

$$53$$

11. Pentane: It is non polar and will not react with sodium Hydroxide solution which is an ionic compound.

12. Tetrachloro methane

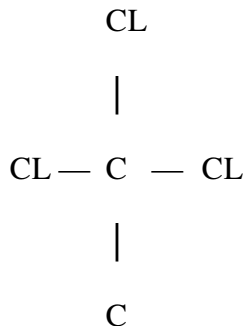

13. -In pentane there will be no reaction

-In pentanol, there will be effervescence and a colourless gas which burns with a "pop" sound produced solution left is alkaline.

14 a)

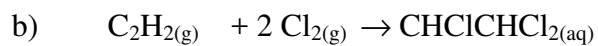
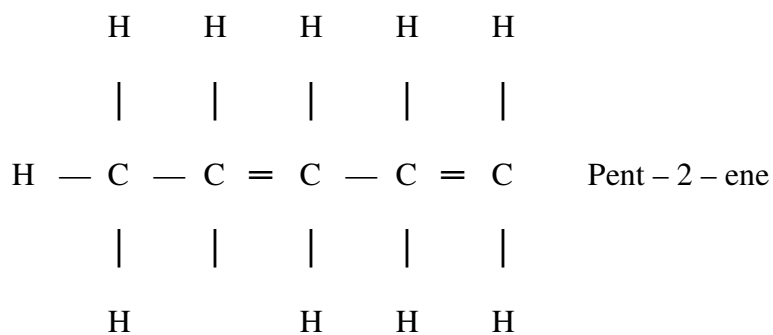
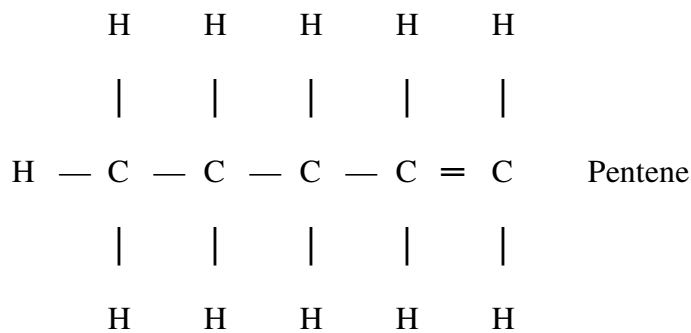

15. Methane/ $\text{CH}_4(\text{g})$

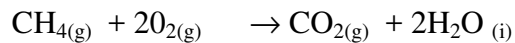

16. a) U.V. light /sunlight
 b) Bonds broken C-H and Br-Br
 Bonds formed C-Br and H- Br

17. a)

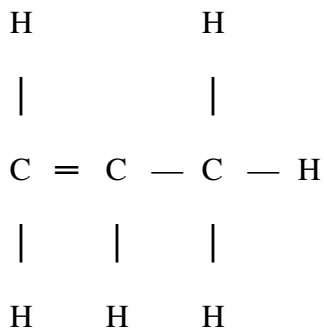

- b) Propene
 c) Petroleum/crude oil/natural gas
18. Add water to the mixture in a separating funnel, ethanol being polar dissolves while pentane does not. Allow the mixture to separate into two layers. Open the tap to drain the lower layer which contain ethanol. Distill the aqueous layer to get ethanol.
19. a) Reaction which one or more hydrogen in alkaene molecule is/are replaced by halogens.

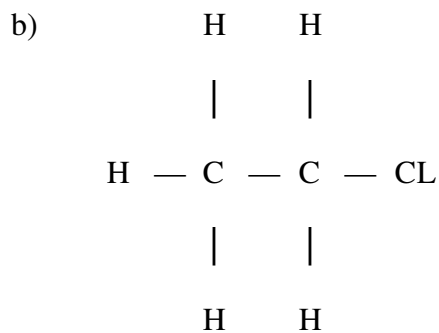

20. a) Butane
 b) Hardening of oil in manufacturer of margarine
21. Butene/but – 1- ene
22. a) Isomerism is the occurrence of tow or more compounds with the same
 molecula formula, but different molecular structure/structural formular.
 b)

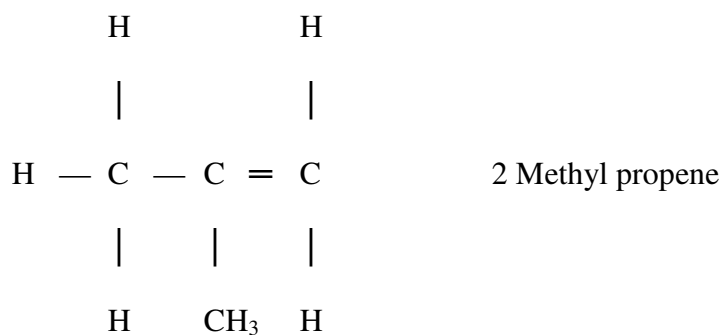
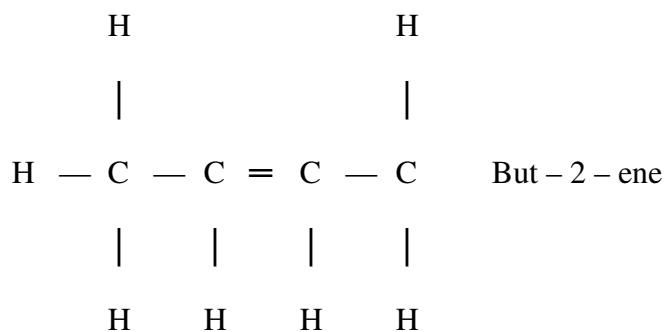
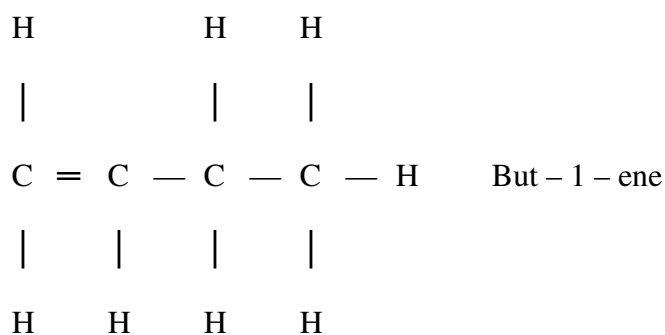

23. Thermal cracking

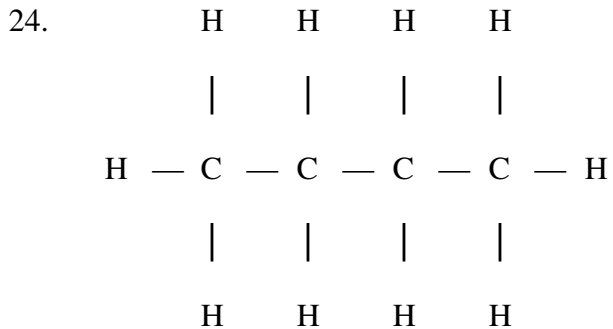

Butane

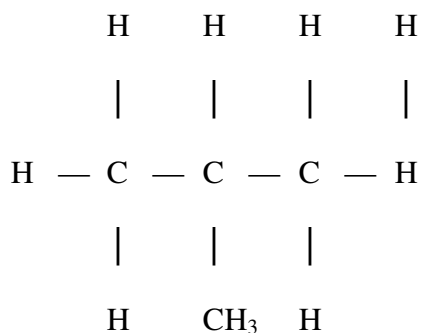

2 Methyl propene

25. (a) $\text{C}_{13} \text{H}_{27} \text{COO}^- \text{Na}^+$
(b) Soapy detergent
(c) $(\text{CH}_3)(\text{CH}_2)_{12} \text{COO})_2 \text{Ca}^{2+}$
 $(\text{CH}_3)(\text{CH}_2)_{12} \text{COO})_2 \text{Mg}^{2+}$

26. (i) $\text{C}_2 \text{H}_4 \text{O}_2$ its melting point is higher than 10^0C

(ii) CH_{14} and $\text{C}_5 \text{H}_{12}$

$\text{C}_6 \text{H}_{14}$ has a higher melting point since it is more bulky compared to $\text{C}_5 \text{H}_{12}$; hence the van der Waals force between the molecules of $\text{C}_6 \text{H}_{14}$ is a bit strong.

iii) C_3H_8O is more soluble in water than C_5H_{12} : because it forms hydrogen bonds with water molecules i.e it is polar due to the presence of (OH) group.

b) i) C_4H_8

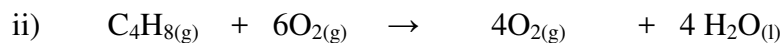

c) i)

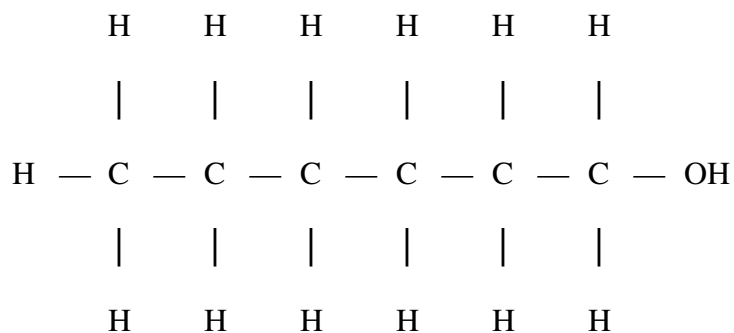

Reagents

- ii). - Concentrated sulphuric acid
- Al_2O_3 or phosphoric acid (Catalyst)

Conditions

Heat (160-180⁰C)

d) i) Saponification/Hydrolysis

ii) Fats/ ester

27. a) i) Butan-1 Ol

ii) Propanoic acid

iii) C_5H_{10}

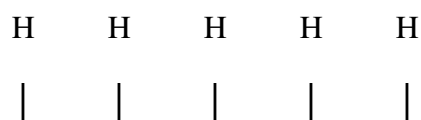

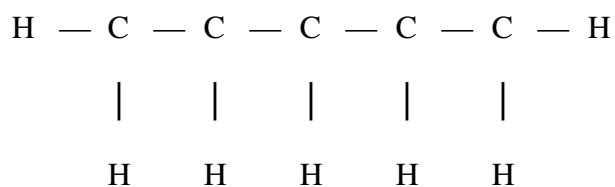

or

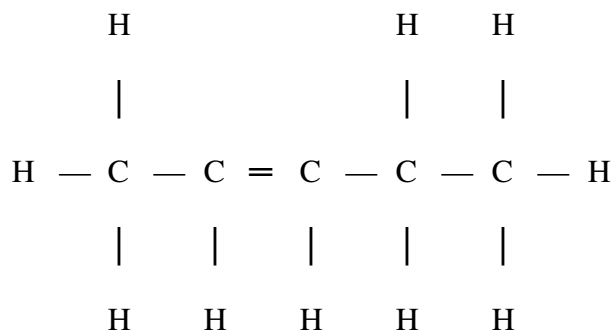

28. a) i) Additional polymerization
- ii) Substitution reaction/chlorination
- b) i) Fractional distillation
- ii) Sink to the bottom: effervescence/fizzing sound as hydrogen gas is produced
- iii) -In thermometers
- Fuel
- Mild disinfectant
- Solvent

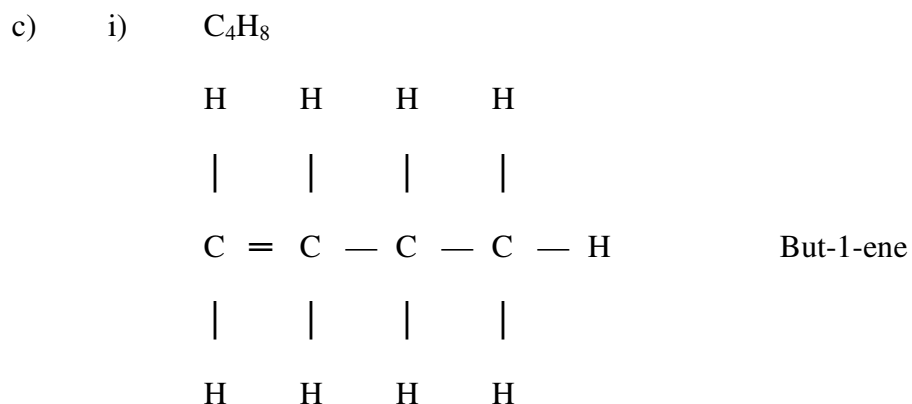

Or

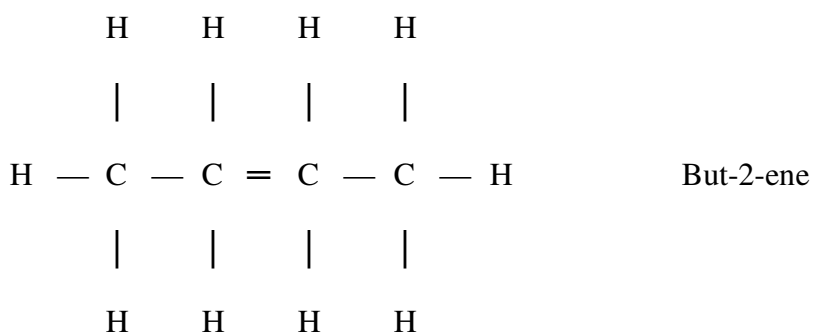

ii) Bromine water is decolourised because “X” is unsaturated or has a (-C=C-) Double bond

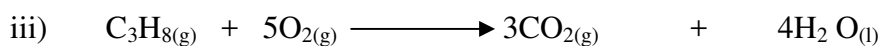

29. a) i) Pent-2-ene
 ii) Butanoic acid

- b) i) Substitution
 ii) Additional

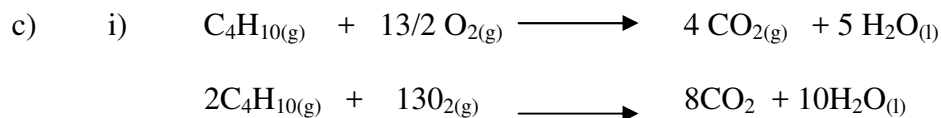

ii) The carbon (IV) oxide gas which is produced is acidic. It dissolves in “K” water to form weak acid: carbonic acid.

d) i) Process whereby monomer (small molecules) join together to form large molecules (Polymers)

ii)

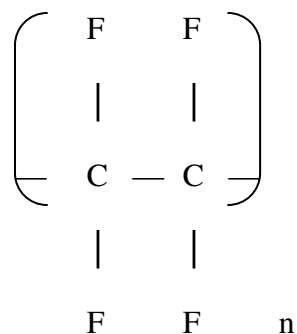

- e) - Cheaper
- More durable
- Stronger
- Can be recycled
- Not attacked by many chemicals
- Corrosion resistant

30. a) i) Alkyne
ii) Carboxylic acid/Alkanoic acid

b) i) vulcanization
ii) To harden rubber/make it tough and stronger

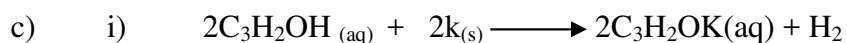

ii) Process I: Dehydration

iii) Additional hydrogenation

A= 1,2 – Dibromoprepene

B=Ethene/ C_2H_4

iv) Nickel/platinum/palladium/platinum

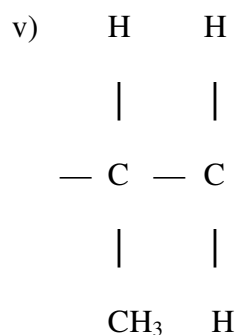

d) - Fuel/ source of fuel

- Production of hydrogen gas

- Production of
- i) CCl_4
 - ii) Trichloromethane
 - iii) Methanol

31. a) Ethane burns with a non luminous flame blue in colour whereas ethyne burns with a luminous (yellow) flame which is very sooty- Ethane is saturated while ethyne is unsaturated with high percentage of carbon-particles.

b)

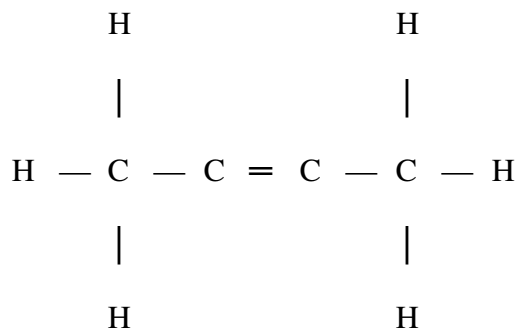

Or

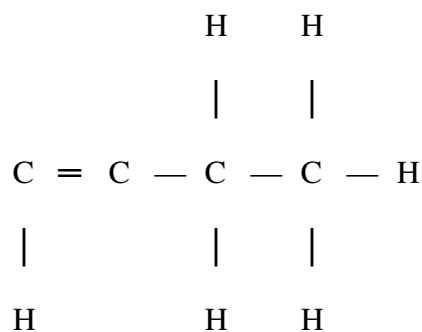

- c) i) A = Oxidation "B is Ethene substance "C" sodium ethanoate
- ii) $\text{C}_2\text{H}_5\text{OH}_{(g)} + \text{O}_{2(g)} \longrightarrow 2\text{CO}_{2(g)} + 3\text{H}_2\text{O}_{(l)}$
- iii) To bring reacting monomers into close contact.
- iv) -As a fuel
 -Carbon black
 -Manufacture of methanol
 -Manufacture of di, tri and tetrachloromethene
32. a) i) Fractional distillation
- ii) boiling point
 molecular mass/ density
- b) i) C_3H_6
- Shake a sample with bromine, C_3H_8 does not decolorize it, but-
 C_3H_6 decolorises it.
- Or
- Use acidifical potassium manganate (VII) C_3H_6 decourise acidified
 potassium chromate (vi) C_3H_6 Change it from orange to green
 while C_3H_6 burns with a smokey luminous flame.

Alternative

Burn a sample of C_3H_8 ; it burns with a non luminous flame. C_3H_6 burns with a smoky luminous flame

c) P1

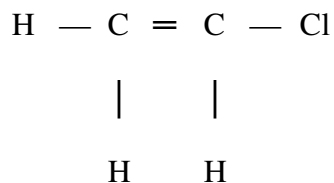

P2

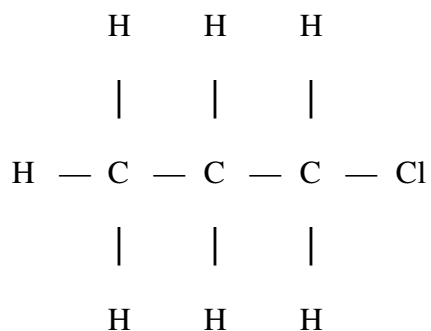

d) i) Ethanol

ii) Slightly soluble in water

e) Name: polythene/polythene

Disadvantages of polythene

-Non biodegradable

-Pollute the environment by producing poisonous gases when burnt

33. a) Hydrocarbons

b) i) fractional distillation

ii) Fuel/component of =petrol/to drive small machines.

c) i) CaC_2 /Calcium distillation

ii) phosphoric acid is the catalyst

iii) $\text{H} - \text{C} \equiv \text{C} - \text{H}$

iv) Hydration

- v) I. - Wire insulation coat
- Water prove seat covers
- Motor cars seat covers
- Shoes
- Suitcase covers

II. Hardening of oil in manufacturing of margarine



ii) Hydrochloric acid is a strong acid with many hydrogen ions to react with the carbonate. It is fully ionized in water. Ethanoic acid is a weak acid with few Hydrogen ions. It is partially ionized in water.

34. a) i) 2- Methy – prop – i-ene

ii) pent –I – yne

35. a) i) Methane is a gas which is flammable in presence of oxygen.

ii) Pass the mixture through a solution of calcium hydroxide to remove CO_2 . Then determine the volume of the gas left using a syringe.

b) i) Mass of methane = $\frac{35.2}{100} \times 5 = 1.76\text{kg} = 1760\text{g}$

$$\text{Moles} = \frac{176}{16} = 0.11 \text{ moles}$$

16

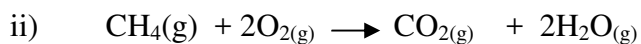

$$\text{Volume} = 0.11 \times 24 = 2.64\text{dm}^3 = 2640\text{cm}^3$$

- c) i) CO_2 causes global warming
-No causes acidic rain
-Trichlorofluoromethane destroy ozone layer
- ii) I. Exhaust from vehicles
II. Aerosal sprays.

36. i) Compounds containing carbon and hydrogen only.
ii) A family of compounds having the same functional group and shows similar chemical characteristics.
iii) A hydrocarbon that contain maximum number of hydrogen atoms possible bonded to carbon atoms.
Existence of different compounds with the same molecular formula but different structural formula.
37. i) But _____ 2 _____ are
ii) 2, Methylbutene
38. i) Step I reagents: Acidified potassium manganate (VIII)
- Potassium dichromate
Conditions: -room temperature and pressure
Step II reagents: -Hydrogen gas
Conditions - Nickel catalyst/heat

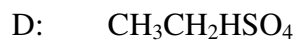
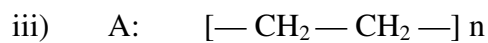

39. i)

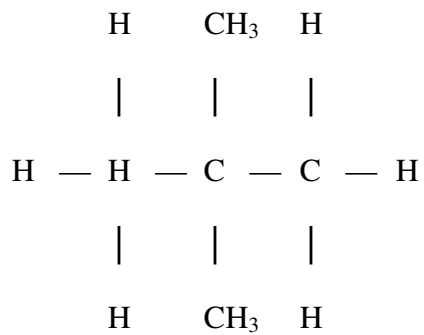

ii)

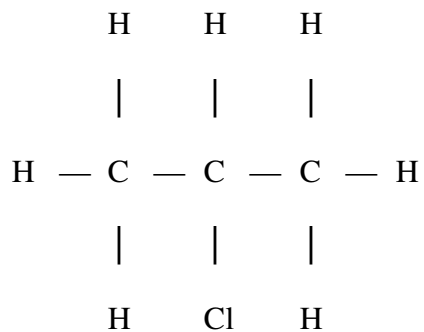

40. a) Increase from "A" to "E"

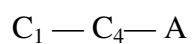
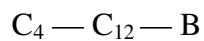
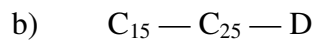

41. Boiling point increases with increases in number of carbon atoms. Pentane molecules are big /large/bulky and the vander waals forces between these molecules is stronger compared to others.
42. i) $C_5 - C_{10}$
 ii) Carbon (ii) oxide / sulphure (iv) oxide/ nitrogen (iv)oxide
43. Sunlight energy split the halogen molecules into free radicle /atoms which are very reactive i.e U.V act as a photocalolyst.

44. i) alkanes
 ii) Name: Propane:

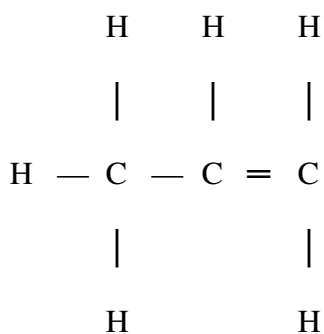

- iii) $\text{CH}_3\text{CH}_{(g)} = \text{CH}_2 + \text{HBr}_{(g)} \rightarrow \text{CH}_3\text{CHBrCH}_3_{(aq)}$
45. i) R: Sodium hydroxide
 ii) T: tetrachloro methane/ carbon tetrachloride
 iii) $\text{CH}_3\text{COONa}_{(s)} + \text{NaOH}_{(aq)} \rightarrow \text{CH}_4_{(g)} + \text{Na}_2\text{CO}_3_{(aq)}$

46. i) Polyethene /polythene
 ii) $(\text{CH}_2 - \text{CH}_2 -)_n = 42000$

$$\begin{array}{rcl}
 28n & = & 42000 \\
 n & = & \frac{42000}{28} = 1,500
 \end{array}$$

$$47. \quad a) \quad (C_2H_3)_n = 54$$

$$27n = \frac{54}{27} = 2$$

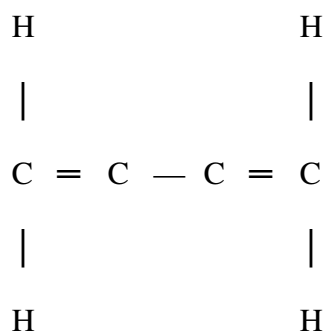
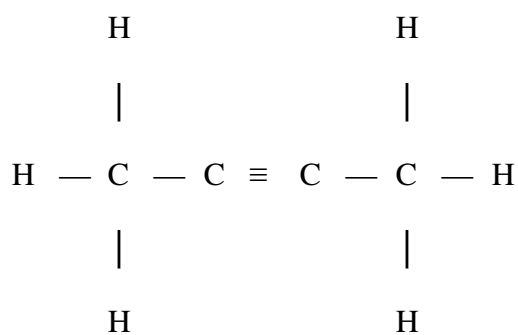
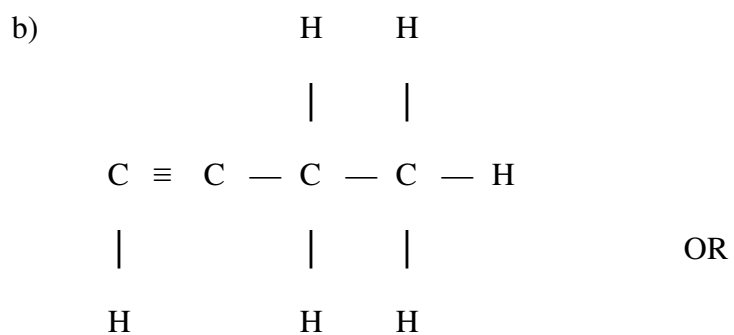

c) Alkyne if it has $[-C \equiv C-]$ or

Alkene if it has $[-C = C-]$



TOPIC 4

NITROGEN AND ITS COMPOUNDS

- Funnel has no tap/ does not dip into the reactant
- Ammonia should not be collected over water as it is very soluble.
- Cracking/ descpitating sound
- Brown gas produced
- Gas which relight a glown splint produced
- Solid change from white to brown when hot and yellow when cold

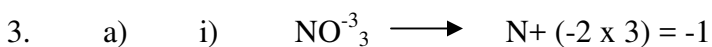

$$\text{N} = -1 + 6$$

$$\text{N} = +5$$



$$\text{N} = 0 + 2$$

$$\text{N} = +2$$

- b) Reduction: because the Nitrogen in NO_3^- ion gains electrons to form No
i.e. the oxidation number reduced from + 5 to +2/ oxygen is removed.

4.

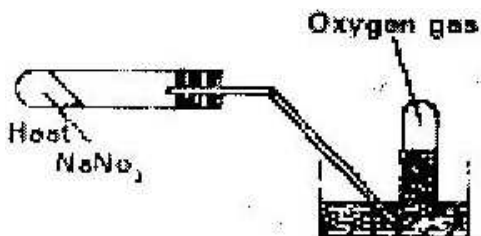

5. Ammonium chloride and calcium hydroxide

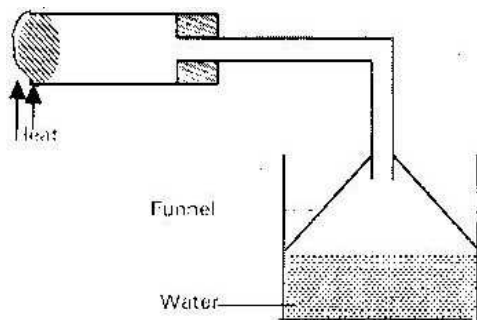

6. $\text{RMM of } (\text{NH}_2)_2\text{CO} = 22 + 4 + 12 + 16 = 60$

$\text{RMM of } \text{NH}_3 = 14 + 3 = 17$

$\text{Moles of } \text{NH}_3 = \frac{680}{17} = 40 \text{ moles}$

17

$\text{Moles of Urea } (\text{NH}_2)_2\text{CO} = 20 \times 60 = 1200 \text{ kg}$

7. a) Zinc /Zc

b) $\text{Zn } (\text{NH}_3)_4^{-2}$

8. a) NaOH or KOH

b) At first, light blue precipitate was formed. In excess the precipitate dissolve to form a deep blue solution.

9. NH_4Cl decomposes to give ammonia and hydrogen chloride gas. Ammonia diffuses faster than hydrogen chloride since it is less dense. Ammonia is basic and Hcl is acidic in presence of moisture.

10. a) Oxygen gas

b) Thermal decomposition

11. Chemical test

Insert a blightly glowing splint it relight

Physical test

- Invert a gas jar of No. if it turns brown it is not N₂O.
 - Invert gas jar of “G” over cold water if the level rises it is N=2O
 - Has a sweet sickly smell
12. a) The solution contained (OH) ions which change litmus to blue/Ammonia is basic in presence of water.
- b) Prevent sucking back of water if the reacting vessel as ammonia is very soluble.
13. a) Nitrogen gas
- b) Withdraw delivery tube from water. This prevent sucking back of water.
14. a) Nitric acid is more volatile than concentrated sulphuric acid or Nitric acid has a lower boiling point than concentrated sulphuric acid. It therefore evaporate readily.
- b) NaNO₃/ Sodium nitrate
- c) - Making ammonium fertilizers
- Making dye
- Making explosions
- Making synthetic fibres/nylon
- Purification of metal/ gold
15. a) Platinized rhodium /gauze
- b) $2\text{NH}_{3(g)} + 5/2\text{O}_{2(g)} \longrightarrow 2\text{NO}_{(g)} + 6\text{H}_2\text{O}_{(l)}$
- Or
- $4\text{NH}_{3(g)} + 5\text{O}_{2(g)} \longrightarrow 4\text{NO}_{(g)} + 6\text{H}_2\text{O}_{(l)}$

- c) - Nitrogenous fertilizers
- Make explosive
16. White flames produces, ammonia react with Chlorine producing hydrogen chloride gas which react with excess ammonia to give ammonium chloride.
17. White solid contain MgO and Mg_3N_2 (magnesium nitride) which react with water to give ammonia gas.
18. a) An alkali is a base that dissolves in water to give hydroxide ions(OH)
- b) i) Ammonia gas is very soluble in water thus it will dissolve in water instead of being collected.
- ii) Ammonia is less dense than air and would therefore not displace air in the collecting jar.
- c) Hydroxyl ions (OH)
- d) Moles of $NH_3 = \frac{120}{24000} = 0.005$ moles
- e) i) The solution of Ammonium phosphate is heated slowly to about half the volume so as to concentrate/saturate it. It is then allowed to cool slowly to form crystals, then filtered.
- ii) From equation 3 moles of ammonia produces 1 mole of Ammonium phosphate ration 3:1
- Moles of $(NH_4)_3 PO_4 = \frac{0.005}{3} = 0.0017$ moles
- RMM $(NH_4)_3 PO_4 = (14 \times 12) + 31 + 64 = 149$

$$\text{Mass} = 0.0017 \times 149 = 0.253\text{g}$$

- 19 a) i) Water
- ii) Black Copper (II) Oxide will change to brown copper metal
- iii) $2\text{NH}_3(\text{g}) + 3\text{Cu}(\text{s}) \rightarrow 3\text{HO}_2(\text{l}) + \text{N}_2(\text{g})$
- iv) (I) Moles ratio of $\text{NH}_3 : \text{N}_2 = 2:1$
 i.e 2 mole NH_3 gives 1 mole N_2
 $\therefore 320\text{cm}^3 \text{NH}_3$ will give $\frac{320}{2} = 160\text{cm}^3$
- (II) Moles of $\text{NH}_3 = \frac{320}{24000} = 0.0133$ Moles
 Moles of $\text{CUO} = 0.0133 \times \frac{3}{2} = 0.02$ moles
 RMM $\text{CUO} = 63.5 + 16 = 79.5$
 Mass of $\text{CUO} = 0.02 \times 79.5 = 1.59\text{g}$
- (III) Excess ammonia dissolve in water to form basic ammonia solution.
- b) The burning splint will be extinguished.
- c) - The method is cheaper
 - Nitrogen will be pure i.e it will not be contaminated by other chemical as is the case when obtained from ammonia.
20. i) Fusses calcium chloride/ CaO (Quick lime)
- ii) To remove Carbon (IV) Oxide
- iii) $4\text{Fe}(\text{s}) + 3\text{O}_2(\text{g}) \longrightarrow 3\text{Fe}_2\text{O}_3(\text{s})$

Or

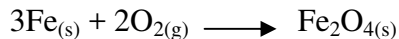

- iv) Argon/helium/ Neon/ Krypton
- v) Provide very low temperature so that the semen does not decompose/ is not destroyed.
- b) i) concentrated sulphuric acid
- ii) $\text{NaNO}_{3(s)} + \text{H}_2\text{SO}_{4(l)} \rightarrow \text{NaHSO}_{4(aq)} + \text{HNO}_{3(aq)}$

Or

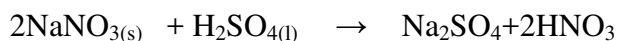

- iii) (I) To avoid decomposition of Nitric acid by Sunlight/ Light
- (II) Copper reacts with 50% nitric acid to give Nitrogen (II) oxide which is colourless. Air oxidises nitrogen (II) oxide to Nitrogen (IV) oxide which is brown.

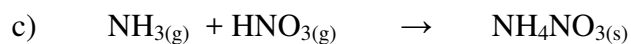

Rmm of $\text{NH}_4\text{NO}_3 = 80$

Moles of $\text{NH}_4\text{NO}_3 = \frac{4800}{80} = 60$ moles

80

From moles ratio 1:1 moles of $\text{NH}_3 = 60$ moles

RMM of $\text{NH}_3 = 17$

Mass of $\text{NH}_3 = 60$ moles

Rmm of $\text{NH}_3 = 60 \times 17 = 1020\text{kg}$

- 21 a) I. Fractional distillation of air
 II. Neutralization
- b) electrolysis of brine/water gas or cracking of alkane.
- c) High pressure brings the molecules closer/increases the concentration of gas molecules/leads to more collision.

Or

High pressure shift the equilibrium to the right hence the yield of more ammonia gas,



e) Catalyst : platinum Rhodium/gauze

Reagent : water and Oxygen

f) Ammonium nitrate

g) A fertilizer/as a fertilizer.

- 22 a) i) Heat
- ii) (I) Soluble carbonate $\text{Na}_2\text{CO}_3/\text{H}_2\text{CO}_3$
 (II) : Oxygen gas
 (III) R = HNO_3 Nitric (V) acid
 S - HNO_2 Nitric (III) acid
- iii) I: $\text{Pb}(\text{OH})_2$
 II: $\text{PbO}(\text{s}) + \text{H}_2(\text{g}) \rightarrow \text{H}_2\text{O}(\text{l}) + \text{Pb}(\text{s})$
- b) i) -Cheap
 -Corrosion resistant
- ii) LEAD IS POISONOUS/ harmful/ affect nervous system/brain

- c) i) The reaction produce insoluble lead (II) sulphate which coats the surface of $\text{Pb}(\text{NO}_3)_2$ preventing further contact.
- ii) Potassium Nitrate or Sodium Nitrate
23. i) $2\text{KNO}_3(\text{s}) \rightarrow 2\text{KNO}_2(\text{aq}) + \text{O}_2$
- ii) $2\text{AgNO}_3(\text{s}) \rightarrow 2\text{Ag}(\text{s}) + 2\text{NO}_2(\text{g}) + \text{O}_2(\text{g})$
24. i) Nitrogen (II) oxide (NO)
- ii) NH_3 (Oxidation NO of N = N + 3 = 0 = -3
 NO_2 (Oxidation NO of N = N - 4 = 0 = +4
 Oxidation No: of N increase from -3 to +4
- iii) $\text{NH}_4\text{NO}_3(\text{s}) \xrightarrow{\text{Heat}} \text{N}_2\text{O}(\text{g}) + 2\text{H}_2\text{O}(\text{g})$
- iv) - Fertilizers
 - To make explosives
- c) i) G
- ii) $\text{E}^{2+}(\text{aq}) + 2\text{OH}^-(\text{aq}) \longrightarrow \text{E}(\text{OH})_2(\text{s})$
25. i) Nitric acid attack, rubber, cork wood and metals
- ii) Due to the presence of Nitrogen (IV) oxide formed by thermal decomposition of Nitric (V) acid.
- iii) By bubbling in air which will make Nitrgen (IV) Oxide to combine with water to given Nitric (V) acid.
26. a) X – Ammonia
 Y- Water
 Z- Nitrogen gas
- b) $\text{NH}_3(\text{g}) + \text{CUO}(\text{s}) \longrightarrow \text{N}_2(\text{g}) + \text{CU}(\text{s}) + \text{H}_2\text{O}(\text{l})$

27. a) In process, p, the mixture is passed through KOH to absorb – Carbon (IV) oxide. While in Q it is passed through concentrated sulphuric acid or fused calcium chloride to absorb water vapour.
- b) By fractional distillation
28. i) $\text{N}_{2(\text{g})} + 3 \text{H}_{2(\text{g})} \longrightarrow 2\text{NH}_{3(\text{g})}$
- ii) Platinum/platinized asbestos/vanadium (V) oxide
- iii) Ammonium Sulphate
29. a) i) Dinitrogen tetra oxide (N_2O_4)
- ii) Nitrogen (IV) oxide (NO_2)
- b) $2\text{NO}_{3(\text{g})} + \text{H}_2\text{O}_{(\text{l})} \longrightarrow \text{HNO}_{3(\text{aq})} + \text{HNO}_{2(\text{aq})}$
30. a) Due to presence of dissolved Nitrogen (IV) Oxide (NO_2)
- b) Nitrogen (IV) oxide (NO_2)
- c) Oxygen gas
- d) Glass wood is to soak up Nitric acid. It also conducts heat to the acid. Sand prevents direct heating to the acid, which might explode i.e prevent bumping which may cause cracking of glass.
- e) $4\text{HNO}_{3(\text{aq})} \longrightarrow 4\text{NO}_{2(\text{g})} + 2\text{H}_2\text{O}_{(\text{l})} + \text{O}_{2(\text{g})}$
31. a) The reaction is highly exothermic and the resultant heat causes the glow.
- b) Brown fume formed when the resultant gas (Nitrogen (II) Oxide) combine with oxygen in air to form Nitrogen (IV) oxide.
32. a) Haber process
- b) Finely divided iron catalyst
- c) Reaction between ammonia and oxygen in presence of platinum gauze

catalyst is exothermic. Brown fumes are due to $\text{NO}_{2(g)}$. Initially there is formation of $\text{NO}_{(g)}$ which is then oxidized in presence of oxygen to form to form brown gas (NO_2)

33. a) $\text{Fe}^{3+}_{(g)}$ and $\text{Cl}^{-1}_{(g)}$
 b) Solid Fe_2O_3
 Brown precipitate FeCl_3
- c) i) $\text{Fe}^{3+}_{(g)} + 3\text{OH}_{(g)} \longrightarrow \text{Fe}(\text{OH})_{3(s)}$
 ii) $2\text{Fe}(\text{OH})_{3(s)} \longrightarrow \text{Fe}_2\text{O}_{3(s)} + 3\text{H}_2\text{O}_{(l)}$
34. a) Impurities/ dust may poison the catalyst
 b) A- Oxygen /air
 B- Ammonia gas
 c) D- catalytic chamber
 E- Oxidation chamber
 F – Absorption chamber
- d) i) $\text{NH}_3(g) + \text{O}_2(g) \longrightarrow \text{NO}(g) + \text{H}_2\text{O}(l)$
 ii) $2\text{NO}_2 + \text{H}_2\text{O}(l) \longrightarrow \text{HNO}_3(aq) + \text{HNO}_2(aq)$
- e) Platinum Rhodium /gauze/catalyst
- f) - Distillation
 - Oxidation of HNO_2 by blowing in air.
- g) - Manufacture of fertilizers
 - Manufacture of dyes
 - Refining precious metals/ gold
 - Manufacture of plastic /nylon

- Manufacture of explosive/dynamites

- h) Concentrated Nitric acid oxidizes copper to copper ions and it self is reduced into Nitrogen (II)Oxide which is colourless and water. Nitrogen (II) Oxide is oxidized by oxygen in air to Nitrogen (IV) Oxide which is brown.

TOPIC 5

SULPHUR AND ITS COMPOUNDS

- V = Barium sulphite / BaSO_3

W = Sulphure (IV) Oxide
- a) Tube I molten sulphure and water: Tube II super heated water.

b) To force the molten sulphur out
- Effervescence. Colourless gas with rotten egg smell. The gas darkens the paper soaked in lead acetate.
- a) T as iron (II) Sulphide

U is hydrogen sulphide gas

b) pass through soluble salt of lead e.g lead (II) nitrate and a black precipitate of PbS is formed.
- i) $\text{SO}_2 : s + -2 \times 2 = 0$

S = +4

$\text{SO}_3 : S + -2 \times 3 = 0$

S = +6

Oxidation number of sulphur increases from + 4 to + 6.

This is oxidation number of nitrogen decreases from + 4 to + 2. This is reduction.

ii) $\text{SO}_{2(g)}$ Sulphur (IV) oxide.
- Due to formation of insoluble barium sulphate which “Coat” the reacting sulphite and stops the reaction.
- Sulphur is made up of poly atomic molecule (S_8 ring). The rings are held together

- by weak vander waals forces. On slightly heating the Vander walls forces are over come and the rings slid over each other. On further heating, the rings open up to form chains of sulphur atoms (S_8) which then entangles making it viscous and dark.
8. SO_2 which is poisonous is released in the air. Acid rain which may cause corrosion will be formed.
 9. Add dilute acid HCl or H_2SO_4 to each substance separately. If it is sodium sulphide (Na_2S) a colourless gas with rotten eggs smell will be produced. If it is sodium carbonate Na_2CO_3 effervescence and a colourless gas that forms white precipitate with lime water is produced.
 10. Black precipitate formed
 11.
 - a) C = Fes or Zns
 - b) Hydrogen sulphide is very soluble in cold water but insoluble in warm water.
 - c) Black precipitate formed.
 12. Concentrated nitric is a strong oxidizing agent. It oxidizes iron (II) sulphate and itself is reduced into nitrogen (IV) oxide gas which is brown and water.
 13.
 - a) $2NaOH_{(aq)} + H_2SO_{4(aq)} \longrightarrow Na_2SO_{4(aq)} + 2H_2O_{(l)}$
 - b) - Blue – litmus paper turns red
- Red litmus paper remains red
 - c) The acid was in excess
 14.
 - a) Rhombic or monoclinic
 - b) - Vulcanization of rubber

- Preparation of calcium hydrogen sulphite which is a bleaching agent
- Manufacture of sulphuric acid
- Gun powder
- Drugs/ointments

15. a) Sulphur (IV) oxide
- b) i) The gas escaped through the thistle funnel
- ii) The gas delivery tube was immersed in the reagents: Gas escape through the thistle funnel.
16. a) Sulphur (IV) oxide
- b) i) The gas escaped through the thistle funnel.
- ii) The gas delivery tube was immersed in the reagents: Gas escape through the thistle funnel
17. a) $\text{H}_2\text{S}: (+ 1 \times 2) + \text{S} = \text{O}$
- $\text{S} = \text{O} + 2$
- $\text{S} = + 2/2 = + 1$
- $\text{S} = + 1$
18. a) solution from yellow/ orange to green
- b) $2, \text{FeCl}_{3(\text{aq})} + \text{H}_2\text{S}_{(\text{g})} \rightarrow 2\text{FeCl}_{(\text{aq})} + 2\text{HCl}_{(\text{aq})} + \text{S}_{(\text{s})}$
- c) Oxidation since hydrogen is removed oxidation number increase from -2 to 0
19. a) Concentrated sulphuric acid.
- b) Solution of blue solution is heated gently till it is half way its volume so as to concentrate it. It is then cooled slowly to obtain the crystals.

- c) An hydrous copper (II) sulphate.
20. The molecules which were in form of a ring open up to give chained molecule (S₈). This entangles each other reducing the flow of molten sulphur in increases its viscosity.
21. a) A black solid is formed
- b) $\text{FeS}_{(s)} + 2\text{HCl}_{(aq)} \longrightarrow \text{FeCl}_{2(aq)} + \text{H}_2\text{S}_{(g)}$
- c) Iron powder has a very big surface area, hence high chance of parcels combining together.
22. Combustion of fuel produces sulphur (IV) oxide (SO₂) which when dissolved in water (rain) cause acidic rain which corrodes buildings and affect plants and animals.
23. i) :I: 18⁰C
 II: at 100C solubility = 153 in 1000cm³
 In 15 litres / 1500cm³ maximum of
 SO₂ $153 = 153 \times \frac{15000}{1000} = 2,295\text{g}$
- ii) Solubility at 23⁰C solubility is 98g/100cm³
 Moles of SO₂ = $\frac{98}{64} = 1.53$ moles
 Moles of NaOH = 2x 1.53 = 3.06 moles
 Volume of NaOH
 = $\frac{3.06 \times 1000}{1000} = 1.53\text{cm}^3$
- 2

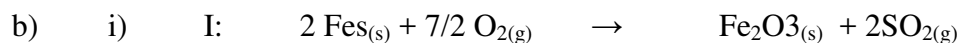

Or

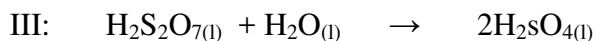
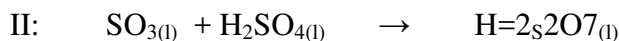

ii) I: To shift equilibrium position to the right and increase the yield of $\text{SO}_{3(g)}$ / Complete oxidation of $\text{SO}_{2(g)}$

II: Vanadium (V) oxide platinum/platinized asbestos

24. (i) A reaction where heat is lost to the surroundings

(ii) The yield will lower: though by le-chatliers principles the yield is expected

to increase, the rate of reaction is lower because the reacting molecules have lower kinetic energy.

iii) $\text{RMM SO}_3 = 32 + 916 \times 3 = 80$

Moles – of = $\text{SO}_3 = \frac{350}{80} = 4.375$

80

$\text{RMMH}_2\text{S}_2\text{O}_7 = 2 + (32 \times 2) + (16 \times 7) = 178$

Mass of oleum = $4.375 \times 178 = 778.75\text{kg}$

25 a) Malachite (CuCO_3 ; $\text{Cu}(\text{OH})_2$)

b) i) Gas p is hydrogen sulphide reagent i.e is $\text{Na}_2\text{CO}_3/\text{K}_2\text{CO}_3$
solid R is CuO /copper (II) Oxide

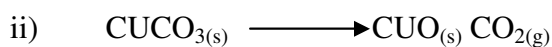

iii) Step 4

(i) – Green solid dissolves to form blue solution

- There is effervescence

Step 7

- Black solid dissolves to form blue solution

c) i) Tin/Sn

ii) Making

- Ornaments

- Medals

- Coins

- Gear wheels

- Clock springs

- Rims

- Metal bearings

- Jewellery/decorations

26 a) Super heated water – tube III/ Outer most/ widest pipe.

b) i) Platinum / vanadium (V) oxide

ii) I: The yield decreases. The high temperature decompose SO_3 or the forward reaction is exothermic hence equilibrium will shift to the left

II: Yield increases: there is increase in pressure: This will make equilibrium to shift to the right

iii) SO_3 is dissolved into concentrated sulphuric acid to form oleum.

The oleum is diluted with water to make sulphuric acid.

c)

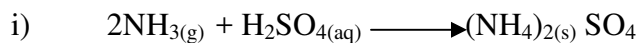

ii) Rmm of $\text{H}_2\text{SO}_4 = 98$

Rmm of $(\text{NH}_4)_2\text{SO}_4 = 132$

Moles of $(\text{NH}_4)_2\text{SO}_4 = \frac{25}{132} = 0.189$ moles

132

Moles of $\text{H}_2(\text{NH}_4)\text{SO}_4 = 0.189$ moles

Mass of $(\text{NH}_4)_2 = 0.189 \times 98 = 18.6\text{kg}$

27. a)

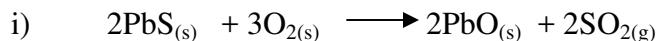

ii)

- Pure so as not to poison the catalyst

- Dry so as not to interfere with collectin of SO_3 which is very soluble.

The H_2SO_4 formed may destroy catalyst.

iii) SO_3 reacts with concentrated sulphuric acid to form oleum

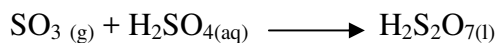
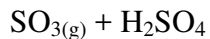

iv)

- Sulphur (IV) oxide

- Dissolves in rain water causing acidic rain

- vi) High pressure will increase the cost of production/even if the pressure is increased more than 3 atmospheres, the yield is not increased
- b) i) Iron fillings
- Effervescence
 - bubbles of colourless gas
 - Greenish solution
- Crystals of white sugar
- Black spongy mass foams off
 - Heat produced
 - Vapour produced
- ii) I. Sulphuric acid is a strong acid
- $$\text{Fe}_{(s)} + \text{H}_2\text{SO}_{4(aq)} \rightarrow \text{FeSO}_{4(aq)} + \text{H}_{2(g)}$$
- II. Concentrated sulphuric acid is a dehydrating agent
- c) Ammonium sulphate
- d) BaSO_4 is insoluble in water hence the paint pigment will not be removed/washed by water.
- 28 i) $S_8 = 256$
- ii) Plastic sulphur
- iii) The rings of 8 atoms open up as the molten sulphur is heated strongly the long chains entangle and make the liquid sulphur to be viscous
- 29 a) The purple $\text{KMnO}_{4(aq)}$ is decolourized
- Yellow solid is formed
- b) KMnO_4 is reduced to colourless Mn^{2+} compounds the H_2S is oxidised to

yellow sulphur

- c) $2\text{MnO}_{4(\text{aq})} + 5\text{H}_2\text{S}_{(\text{g})} \longrightarrow 6\text{H}^+_{(\text{aq})} + 2\text{Mn}^{2+}_{(\text{aq})} + 8\text{H}_2\text{O}_{(\text{l})} + 5\text{S}_{(\text{s})}$
30. a) i) Sulphure
ii) Vanadium (V) oxide/ platinum
- b) i) Forward reaction is favoured hence more yield of sulphur (IV) oxide
ii) Low yield of SO_3 since backward reaction is favoured because the reaction is exothermic.
- c) i) $\text{SO}_{3(\text{g})} + \text{H}_2\text{SO}_{4(\text{l})} \longrightarrow \text{H}_2\text{S}_2\text{O}_{7(\text{l})}$
ii) $\text{H}_2\text{S}_2\text{O}_{7(\text{l})} + \text{H}_2\text{O} \longrightarrow 2\text{H}_2\text{SO}_{4(\text{l})}$
31. - Solution turns from yellow to green and yellow deposit of sulphur formed
- Hydrogen sulphide is a reducing agent: it reduces Fe^{3+} to Fe^{2+} and itself is oxidized to sulphur .
32. - Sugar changes to brown and then black sugar charred off to give a black spongy mass of carbon.
- Vapour produced
- A lot of heat given out.
33. a) i) Sulphur (IV) oxide - A
ii) Oxygen - B
iii) Platinum/platinized asbestos/ vanadium (V) oxide p
- b) $2\text{SO}_{2(\text{g})} + \text{O}_{2(\text{g})} \rightarrow 2\text{SO}_{3(\text{g})}$
34. $\text{Cl}_{2(\text{g})} + \text{SO}_{2(\text{g})} + 2\text{H}_2\text{O}_{(\text{l})} \rightarrow 2\text{HCl}_{(\text{aq})} + \text{SO}^{2-}_{4(\text{aq})} + 4\text{H}^+_{(\text{aq})}$ or
 $\text{Cl}_{2(\text{g})} + \text{SO}_{2(\text{g})} + 2\text{H}_2\text{O} \rightarrow 2\text{HCl}_{(\text{aq})} + \text{H}_2\text{SO}_{4(\text{aq})}$

35. a) P- Barium sulphite
 b) $2\text{HNa}_2\text{SO}_3$
 c) $\text{BaSO}_3(\text{s}) + 2\text{HNO}_3(\text{aq}) \rightarrow \text{Ba}(\text{NO}_3)_2(\text{aq}) + \text{SO}_2(\text{g}) + \text{H}_2\text{O}(\text{l})$
36. i) Existence of a substance in a more than one form in the same physical state
 ii) Carbon
 iii) Rhombic and monoclinic
 iv) -Manufacture of sulphuric acid
 -Vulcanization of rubber
 -Fungicide

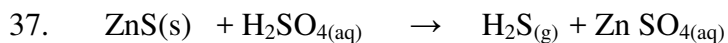

Moles of $\text{H}_2\text{SO}_4 = \frac{0.2 \times 100}{100} = 0.02$ moles

100

RMM of $\text{ZnS} = 97$

Moles of $\text{ZnS} = \frac{9}{97} = 0.09$ moles

ZnS is in excess by $0.09 - 0.02 = 0.07$ moles

TOPIC 6

Chlorine and its compounds

1. a) $\text{Cl}_{2(g)} + 2\text{NaOH}_{(aq)} \longrightarrow \text{NaCl}_{(aq)} + \text{NaOCl}_{(aq)} + \text{H}_2\text{O}_{(l)}$
b) NaOCl; decomposes to give oxygen atom that bleaches the dye/bleaches by oxidation.
2. a) additional chlorination
b) $\text{CH}_3\text{CH}=\text{CH}_{2(g)} + \text{Cl}_{2(g)} \longrightarrow \text{CH}_3\text{CHClCH}_3_{(aq)}$
3. a) Sunlight U.V
b)
$$\begin{array}{ccccccc} & \text{H} & & \text{H} & & \text{H} & \\ & | & & | & & | & \\ \text{H} & - \text{C} & - & \text{C} & - & \text{C} & - \text{Cl} \\ & | & & | & & | & \\ & \text{H} & & \text{H} & & \text{H} & \end{array}$$
4. a) Yellow deposit of sulphur.
b) $\text{H}_2\text{S}_{(g)} + \text{Cl}_{2(g)} \rightarrow 2\text{HCl}_{(g)} + \text{S}_{(s)}$
c) In the fume cupboard since Cl_2 is poisonous or in the open air.
5. a) i) Concentrated $\text{HCl}_{(aq)}$ hydrochloric acid
ii) Concentrated sulphuric acid H_2SO_4
b) More dense than air
6. a) Chloric acid/ hypochlorous acid decompose to form atomic oxygen which oxidizes the dye and bleaches it
b) $2\text{HOCl}_{(lq)} \rightarrow 2\text{HCl}_{(aq)} + \text{O}_{2(g)}$
7. a) Iron (II) Chloride

- b) The solution was basic PH 14. Excess Hcl neutralized the alkali and the solution became acidic as Hcl is acidic .
8. a) Cao is basic will Hcl is acidic. They will react to form salt and water.
 b) Silical gel/ conc. H₂SO₄/ used Cacl₂
9. a) $2\text{NaOH}_{(aq)} + \text{Cl}_{2(g)} \rightarrow \text{NaOCl}_{(aq)} + \text{H}_2\text{O}_{(l)}$
 b) - Bleaching agent.
 - Oxidising agent
10. Add silver nitrate solution white precipitate is formed which change to violet when exposed to light.
 White precipitate on adding lead nitrate. The precipitate dissolves on warming.
11. a) It is drying agent
 b) $2\text{HCl}_{(g)} + \text{Fe}_{(s)} \rightarrow \text{FeCl}_{2(aq)} + \text{H}_{2(g)}$
 c) -Picking of metals
 -Making dye, drugs

12.

No.	Gas	Test	Observation
I	Chlorine	Put a moist red litmus paper into the gas.	Turns red than white/bleached
II	Sulphur(IV) oxide	Potassium dichromate	Paper turns green
III	Butane	Add a drop of bromine water	Colourless solution

13. a) O₂(Oxygen gas)
 b) PH drops: HOCL decompose to give HCL, which is a strong acid.

14.

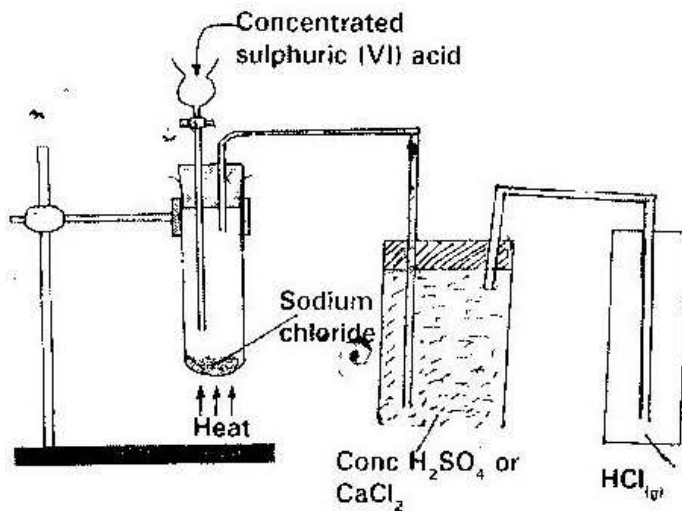

15. a) i)

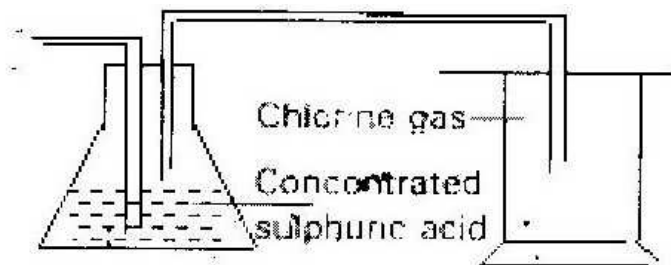

ii) Remove $HCl(g)$ sprays

iii) In MnO_2 manganese (Mn) is reduced. Mn in (MnO_2) has oxidation number +4 but in $MnCl_2$ it has oxidation number +2

16. a) To remove oxygen / air which would react with the element to form an oxide.

b) To absorb excess/unreacted chlorine

To absorb moisture from the atmosphere

c) Sodium chloride has a high boiling point and the burner's temperature is not able to vaporize the sodium chloride

d) Calcium oxide /quick lime

- e) $2\text{P}_{(s)} + 3\text{Cl}_{2(g)} \rightarrow 2\text{PCl}_{3(g)}$
 $\text{P}_{4(s)} + 6\text{Cl}_{2(g)} \rightarrow 4\text{PCl}_{3(g)}$
- f) Heat the mixture aluminium chloride sublimes, cool the vapour to obtain aluminium chloride. Sodium chloride is left in the heated vessel.

17 i)

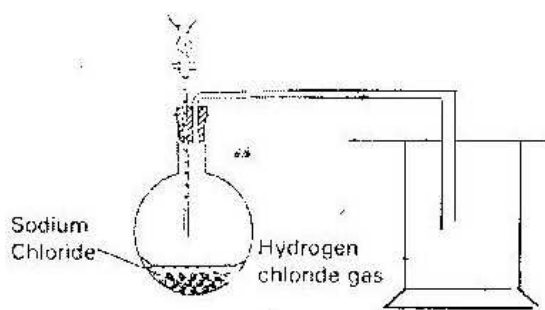

- ii) $\text{NaCl}_{(s)} + \text{H}_2\text{SO}_4 \longrightarrow \text{NaHSO}_{4(aq)} + \text{HCl}_{(g)}$
- iii) Concentrated sulphuric acid/used calcium chloride or silica gel.
- iv) A white precipitate is produced. $\text{HCl}_{(g)}$ in water ionize to give H^+ and Cl^- ions. The Cl^- combines with Pb^{2+} ions to form PbCl_2 .
- v) HCL is not an oxidizing agent, it only reacts and removes the oxides hence clearing the surface. HNO_3 is a strong oxidizing agent. It re oxidizes the cleaned surface.

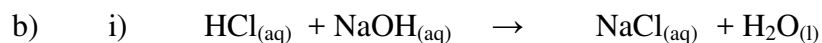

Modes of NaOH = Modes of HCl

$$= \frac{46 \times 11}{100} = 0.506 \text{ modes}$$

1000

ii) Moles of HCl in 250cm^3
 $= \frac{0.506 \times 250}{25} = 5.06 \text{ moles}$

Rmm HCl = 36.5

Mass = $36.5 \times 4.06 = 184.69\text{g}$

18. a) - potassium manganate (vii)
- Lead (IV) oxide
- Manganese (IV) oxide
- Calcium chlorate (CaOCl_2)

b) i) to remove all the oxygen which would form iron (iii) oxide instead of iron (iii) chloride.

ii) CaO can absorb both Cl_2 and moisture, CaCl_2 can only absorb moisture.

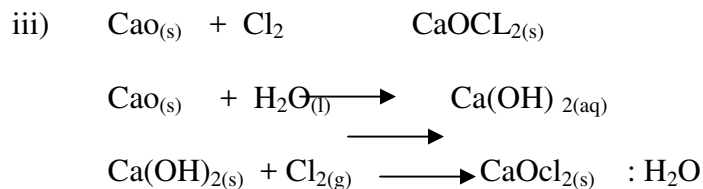

iv) RMM $\text{FeCl}_3 = 162.5$

Moles of $\text{FeCl}_3 = \frac{0.5}{162.5} = 0.003$

Moles of $\text{Cl}_2 = 3 \times 0.003 = 0.0045$

Vol of $\text{Cl}_2 = 0.0045 \times 24000 = 110.8\text{cm}^3$

c) Fe^{3+} is reduced to Fe^{2+} ; H_2S is oxidized to sulphur

- d) Turns, red then white because chlorine is acidic and a bleaching agent in presence of water.
19. a) i) Sodium hydroxide solution \rightarrow A
Ethane \rightarrow B
- b) Additional polymerization
- c) - Making water prove pipes
- making electric insulators
- making water pipes.
- d. $2\text{Cl}^- + 2e_{(\text{aq})} \rightarrow \text{Cl}_2$
- e) Dark brown solid is formed. Chlorine is more reactive than iodine. It displaces it from solution.
- f) i) $\text{NaOH} + \text{Cl}_2 \rightarrow \text{NaCl} + \text{NaOCl} + \text{H}_2\text{O}$
- ii) a) Moles = $\frac{2 \times 15000}{1,000} = 30$ moles
- b) Rmm NaOCl = 74.5
Moles of NaOCl = $\frac{30}{2} = 15$
Mass of NaOCl = $15 \times 74.5 = 1117.5\text{g}$
 $= 1.1175\text{kg}$
20. a) i) Greenish yellow gas
ii) Slightly soluble
iii) Black/Grey solid
- b) i) $4\text{HCl}_{(\text{aq})} + \text{MnO}_{2(\text{s})} \rightarrow \text{MnCl}_{2(\text{s})} + 2\text{H}_2\text{O}_{(\text{l})}$
- ii) To oxidise the chloride ions to chlorine gas/ oxidizing agent

c) i) Iron ii) Chloride → E

iii) Mass of chlorine = 8.06 – 6.30 = 1.76

Rmm of Cl₂ = 71

Moles of Cl₂ = $\frac{1.76}{71}$ = 0.0248

71

Vol = 0.0248 x 24000 = 595.2 am³

H H

| |

d) CL — C — C — CL 1,2 Dichloroethane

| |

H H

e) - Manufacture of HCL

- Manufacture of PVC, DDT

- Manufacture of antiseptic.

21. a) - Carry experiment in a fume cupboard

- Chlorine should not be allowed to escape to the atmosphere.

b) MnO₂ or K₂Cl₂O₇

c) General chlorine and drive out air which may combine with heat aluminium foil.

d) Aluminium chloride sublime when heated.

e) i) 2AL_(s) + 3Cl_{2(g)} → 2ALCL_{3(s)}

Moles of AL = $\frac{1.08}{27}$ = 0.04

27

$$\text{Moles of Cl}_2 = 0.04 \times 3 = 0.06$$

$$\text{Mass of Cl}_2 = 0.06 \times 71 = 4.26\text{g}$$

$$\text{ii) } \frac{3.47 \times 100}{4.26} = 81.45\%$$

$$4.26$$

- f) Pass the vapour of phosphorous trichloride through a liebig's condenser to condense it.
22. i) They react to form a yellow solution of sodium hypochlorite and sodium chloride.
- ii) $2 \text{NaOH}_{(\text{aq})} + \text{Cl}_{2(\text{g})} \longrightarrow \text{NaOCl}_{(\text{aq})} + \text{NaCl}_{(\text{aq})} + \text{H}_2\text{O}_{(\text{l})}$
23. i) FeCl_3 /iron (III) Chloride
- ii) Reddish brown precipitate
- iii) $2\text{NaOH} + \text{FeCl}_{3(\text{aq})} \longrightarrow \text{Fe}(\text{OH})_{3(\text{s})} + 5\text{NaCl}_{(\text{aq})}$
24. $\text{HCl}_{(\text{g})}$ in water ionized while $\text{HCl}_{(\text{g})}$ in methyl benzene dissolves as a molecule.
 HCl in water is acidic due to (H^+) ions
25. a) Potassium manganate (vii)
- b) Chlorine gas reacts with ammonium gas to produce white fumes of ammonium chloride.
26. a) W Dry hydrogen gas
Y Dry chlorine gas
- b) To increase the surface area for absorption of $\text{HCl}_{(\text{g})}$ / Hydrogen chloride gas.
- c) $\text{H}_{2(\text{g})} + \text{Cl}_{2(\text{g})} \longrightarrow 2\text{HCl}_{(\text{g})}$
- d) Due to the presence of dissolved chlorine gas.

27. i) lack of inverted funnel/ dissolution through a delivery tube.
- ii) $\text{HCl}_{(g)}$ is a molecular / covalent compound lacking free ions while hydrochloric acid is ion; the free ions facilitate the reaction.
28. a) A \longrightarrow Hydrogen chloride
 D \longrightarrow Chloride gas
 B \longrightarrow Hydrochloric acid
 E \longrightarrow Iron (ii) Chloride
 F \longrightarrow Iron(iii) chloride
 J \longrightarrow Hydrogen gas
 Q \longrightarrow Zinc
 K \longrightarrow Zinc (ii) Chloride
- b) Solution B: Turns blue litmus paper to red.
 Solution C: No effect on the litmus paper
- c) E Green precipitate
 F Brown precipitate
- d) i. - Excess chlorine
 - Chlorine is an oxidizing agent
- ii. Potassium manganate(VII) or Manganese (IV) Oxide.
- e) Heat
29. a) - Effervescence
 - Green yellow gas
- b) - Use concentrated sulphuric acid as a drying agent
 - Heat the reactant

c) To remove HCL_(g) sprays

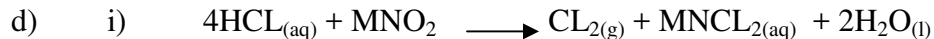

ii) To oxidize HCL to form chlorine

e) Mole of HCL = $\frac{40 \times 11}{1000} = 0.44$ moles

1000

Moles of CL₂ = $\frac{.44 \times 1}{1000} = 0.11$ moles

1000

RMM of CL₂ = 71

Mass = 71 x 0.11 = 7.81g

f) Fe	Cl
<u>0.28</u>	<u>0.53</u>
56	35.5

<u>0.005</u>	<u>0.0149</u>
--------------	---------------

0.005	0.005
-------	-------

1	3
---	---

FeCl ₃	Empirical formula
-------------------	-------------------

g) Hydrogen and water

30. a) Concentrated Hydrochloric acid and potassium manganate (VII) or manganese (IV) oxide.

b) Prevent formation of tri-iron oxide (Fe₂O₄) which will coat the iron preventing reaction with chlorine.

- c) It sublimes
- d) Calcium oxide; to absorb excess chlorine gas and water vapour.
- e) fume cupboard/open field; chlorine is poisonous
- f) $2\text{Fe}_{(s)} + 3\text{Cl}_{2(g)} \longrightarrow 2\text{FeCl}_{3(s)}$
- g) Yellow solid / sulphur.
31. a) hydrogen chloride
- b) $\text{NaCl}_{(s)} + \text{H}_2\text{SO}_{4(aq)} \longrightarrow \text{NaHSO}_{4(aq)} + \text{HCl}_{(g)}$
- c) Dense than air.
- d) Concentrated sulphuric acid
- e) i) -Increase the surface area for dissolution of gas
 - Prevent water sucking back
- ii) Silver chloride
- $\text{Ag}^+_{(aq)} + \text{Cl}^-_{(aq)} \longrightarrow \text{AgCl}_{(s)}$
- iii) Hydrochloric acid

FORM 4 WORK

TOPIC 1

ENERGY CHANGES

1. a) $100 - 389 = 289 \text{ kJ/ mole}$
b) Exothermic: Energy in the reactant is higher than that of the products.
2. a) $\text{Mg} + \text{Fe}^{2+} + \text{Fe}^{2+} \longrightarrow \text{Mg}^{2+} + \text{Fe}_{(s)}$
b) Heat change = $100\text{g} \times 6.0 \times 4.2 = 2520\text{j}$
Mole of $\text{Fe}^{2+} = \frac{100 \times 0.5}{1000} = 0.05 \text{ moles}$
Molar heat = $\frac{2520}{0.05} = 50400 = 50.4\text{kJ/moles}$
3. Enthalpy of neutralization between CH_3COOH and $\text{NaOH}_{(aq)}$ is low than that between HCL and NaOH because CH_3COOH is a weak acid which does not dissociate fully in water. HCL is a strong acid. Some of the energy produced is used to dissociate CH_3COOH so as to produce more (H^+)
4. a) The energy change that takes place when one mole of a compound is formed from its constituents elements in their standard states.
b) $(3 \times 286) + (2 \times 394) - (-277)$
 $-853 - 788 + 277 = -136\text{kJ/mole}$
5. $\Delta H = 500 \times 9 \times 4.2 = 18900 \text{ joules}$
 $\therefore 18900 \text{ J are produced by } 0.06 \text{ of J}$
 $\therefore 38000 \text{ J are produced by } 0.6 \times \frac{38000}{18900} = 12$

6 a) ΔH : Activation energy

ΔH_3 : Heat of reaction`

$$\Delta H_3 = \Delta H_1 + \Delta H_2$$

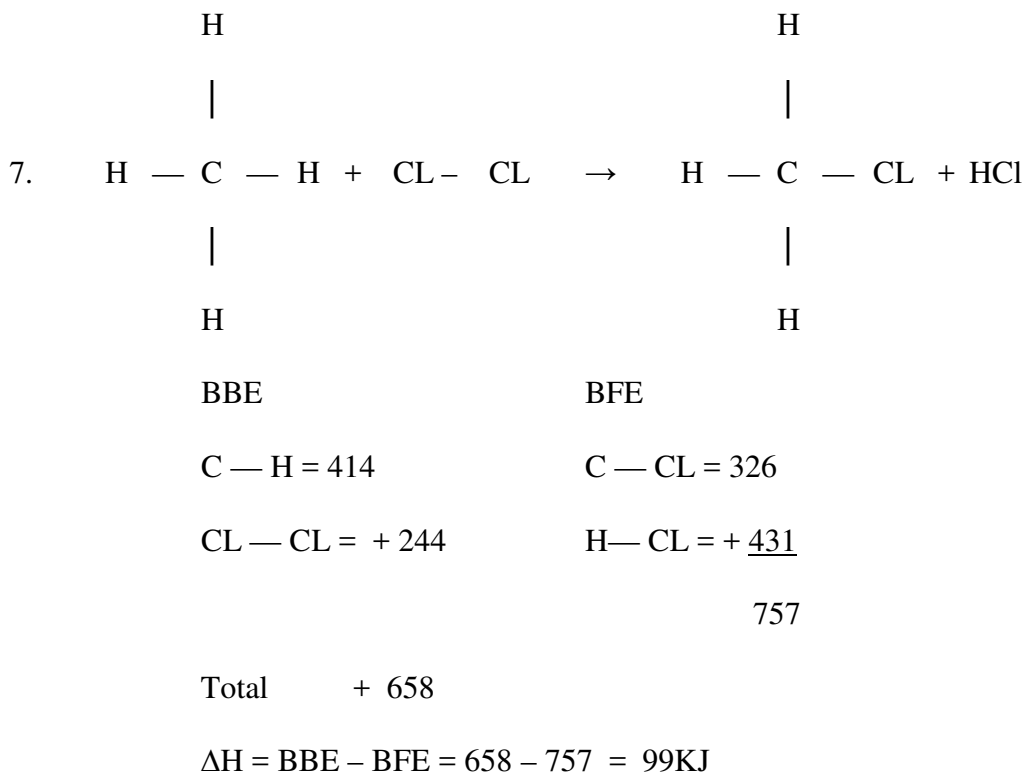

8. $\text{HF}(\text{products}) - \text{Hf}(\text{reagents})$

$$-1207 - (-394 - 635) = -1207 + 394 - 635 = -175\text{kJ}$$

9. a)

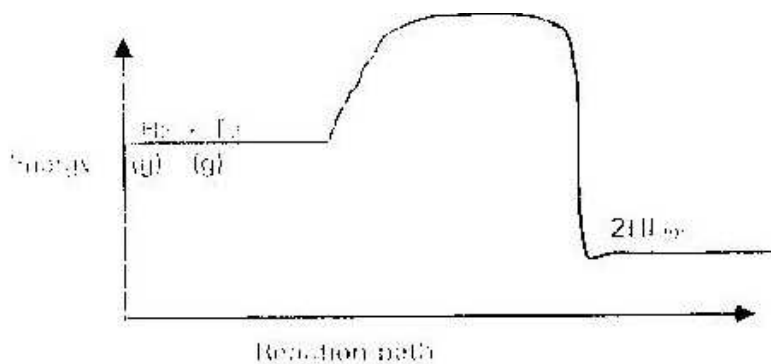

b) $\frac{538}{1} = 269 \text{ KJ}$

1

10. It reacts with $\text{NaHCO}_3(s)$ to form CO_2 which causes the dough to rise.

11. a) $H_1 =$ Lattice energy

b) Let the heat be $\Delta H_3 \therefore H_3 + - 70 = 15$

12. $\Delta H_1 - \Delta H_2 = \Delta H_3$

$- 1673.6 - (-836) = \Delta H_1$

$\Delta H_1 = 836.2 \text{ JK/mole}$

13. a) The heat absorbed by a mole of a substance to change from liquid state to gases state at constant temperature.

b) Boiling point increases with increase in molecular mass. This is due to increase in strength of vander waals forces.

14. Moles of $\text{CuSO}_4 = \frac{900}{1000} = 0.9$ moles

$$1000$$

Moles $\text{BaCl}_2 = \frac{600}{1000} = 0.6$ moles

$$1000$$

Heat change when 0.6 moles BaCl_2 are used

$$= 17.7 \times 0.6 = 10.62 \text{ KJ}$$

$$1500 \times 4.2 \times \Delta T = (10.62 \times 1000) \text{ J.}$$

$$\Delta T = \frac{10.6 \times 1000}{1500 \times 4.2} = 1.7^\circ\text{C}$$

$$1500 \times 4.2$$

15. There is a constant increase in mass caused by constant addition of $-\text{CH}_2$ group.

a)

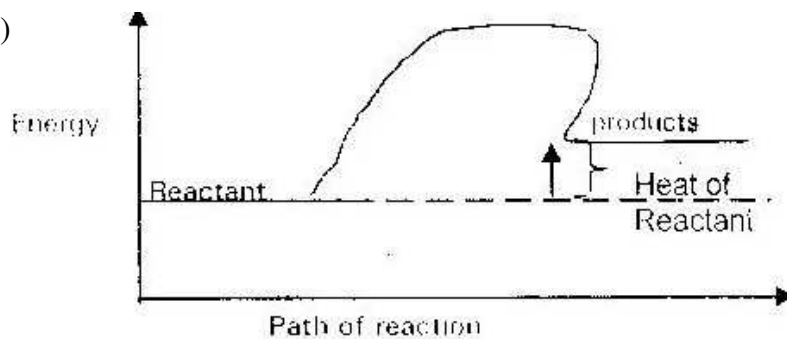

b) Δ Endothermic reaction. The products are at a higher energy levels than the reactants.

16. First ionization energy decreases with increase in atom radius. When the atom radius increases the uppermost electrons get further from the nucleus, less energy is thus required to remove it.
17. a) Latent heat of fusion
b) Negative: particles are losing energy
19. a) Pale yellow liquid produced. The equilibrium moves/shift to the right so as to raise the temperature. The forward reaction is exothermic and will be favoured by low temperature.
b) Brown fume; reducing the volume of gases mixture will lower the pressure hence; equilibrium shift to the left so as to raise the pressure.
20. a) Particles gain more kinetic energy and move very fast.
b) X Y
c) The heat added at the point helps to overcome the force of attraction between water molecules i.e latent heat of vaporization
21. a) $\Delta H_1 = \Delta H_{\text{lattice}} / \text{latent heat of dissolution}$
 ΔH_2 Heat of hydration
b) $\Delta H_3 = \Delta H_1 + \Delta H_2$
22. i) $\text{H}_2 + \text{O}_{2(\text{g})} \longrightarrow \text{H}_2\text{O}_2$ $\Delta H = -1333 \text{KJ mol}^{-1}$
ii) $\text{H}_2\text{O}_{(\text{l})} \longrightarrow \text{H}_{2(\text{g})} + \text{O}_{2(\text{g})}$ $\Delta H_{\text{F}} = + 188 \text{kJ mol}^{-1}$
iii) $\text{H}_2\text{O}_{(\text{l})} \longrightarrow \text{H}_2\text{O}_{2(\text{g})}$ $\Delta H = + 55 \text{KJ mol}^{-1}$

23.

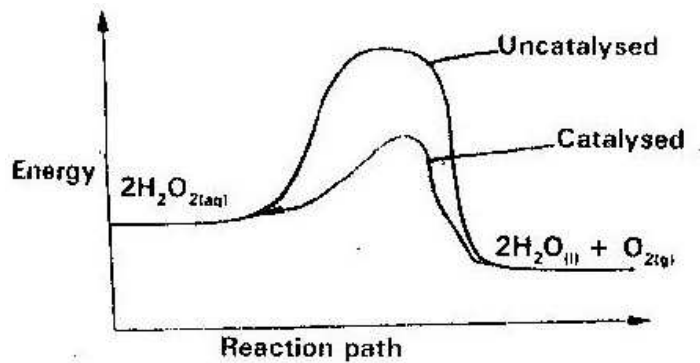

24. “J” It is very soluble in water at a very low temperature. Its solubility decreases with increase in temperature.

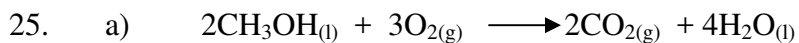

b) i) Mass of methanol = $22.98\text{g} - 22.11 = 0.87\text{g}$

RMM of $\text{CH}_3\text{OH} = 32$

Moles = $\frac{0.87}{32} = 0.027$ moles

32

ii) $\Delta T = 27 - 20 = 7^\circ\text{C}$

$H = 500 \times 7 \times 4.2 = 14700\text{J}$

iii) $\Delta H_C = \frac{14700}{0.027} = 544.4\text{kJ}$

0.027×1000

c) -Heat loss to the surrounding from the apparatus

- Incomplete combustion of methanol

d)

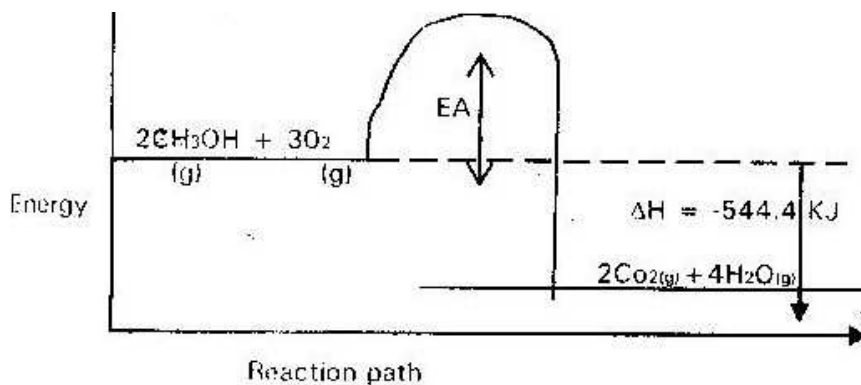

26. a) i) To get uniform mixture hence uniform distribution of heat.
For complete neutralization
- ii) $\text{H}^+_{(\text{aq})} + \text{OH}_{(\text{aq})} \longrightarrow \text{H}_2\text{O}_{(\text{l})}$
- iii) I. Significance of Y2- Neutralization /end point neutralization point.
II. Y1 and Y2: Neutralization is taking place producing heat.
III. Y2 and Y3: reaction has come to an end and the products are cooling / losing heat to the surrounding.
- iv) I: $\Delta H = MC\Delta T$
 $\Delta T = 30.9 - 24.5 = 6.4 \text{ } ^\circ\text{C}$ $M = 200\text{g}$
 $\Delta H = 200 \times 6.4 \times 4.2 = 53765 = 5.376\text{KJ}$
Mole of NaOH = $\frac{100 \times 1}{1000} = 0.1$ moles
 $\Delta H_{\text{Nt}} = \frac{5376}{0.1} = 53760\text{J} = 53.76\text{KJ}$
Mole heat of neutralization = 53.76 KJ/mol

- v) It will be low since ethanoic acid is a weak acid and it is partially ionized in water, a lot of energy will be used to ionize the molecule further. HCL is a strong acid fully ionized.

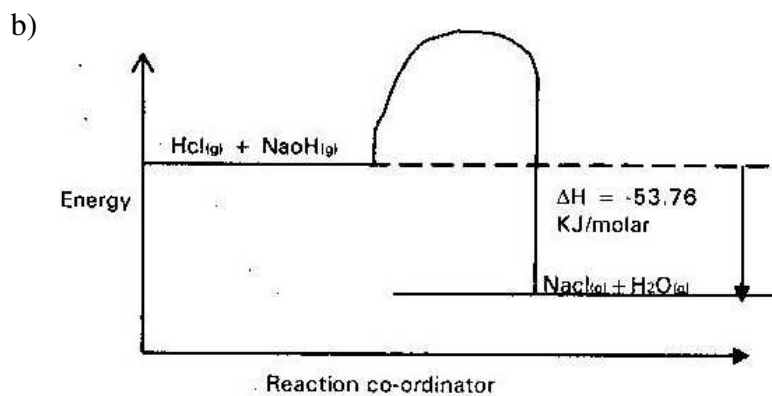

27. a) Exothermic: heat energy is given out to the surrounding.
Endothermic; Heat energy is absorbed from the surrounding.
- b) i) Vaporization /melting
ii) Condensation /freezing
- c) The water is undergoing change of state. The heat supplied is used in breaking the inter particles forces between molecules of water.
- d) i) Heat of formation of FeCl_3 (ΔH_1)
ii) $\Delta H_3 = \Delta H_1 + \Delta H_2$
- e) Butane: because more bonds are formed on combustion of butane hence more heat is released. Butane has the higher percentage of carbon.
28. a) i) -There is a redish brown deposit of copper
-Blue colour of solution fade/become colourless
-Grey solid of magnesium dissolve

ii) $\Delta H = MC\Delta T$

$\Delta T = 43 - 25 = 18^{\circ}\text{C}$

$\Delta H = 25 \times 4.2 \times 18 = 1890\text{J}$

iii) Moles of mg = $\frac{0.15}{24} = 0.00625$ moles

24

Moles of $\text{CuCl}_2 = \frac{25 \times 2}{100} = 0.05$ moles

100

$\Delta H_{\text{ppt}} = 1891 \times 1 = \underline{302400\text{J}}$

0.00625

Molar heat of displacement = -302.4 KJ

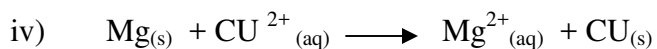

b)

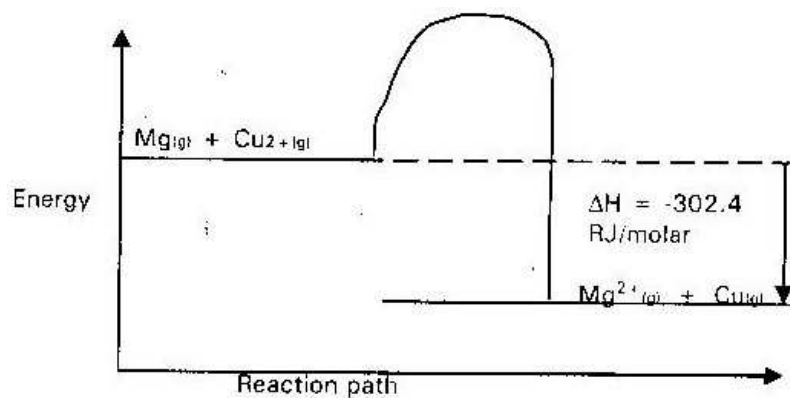

29. a) -the type of flame it produces.

-amount of heat energy produced

b) i) Heat produced = $MC\Delta T$

$\Delta T = 46.5 - 25 = 21.5^{\circ}\text{C}$

$\Delta H = 450 \times 4.2 \times 21.5 = 40635$ joules

ii) Moles of ethanol = $\frac{1.5}{46} = 0.0326$

46

Molar heat = $\frac{40635}{0.0326} = 1246472.392$ joules

0.0326

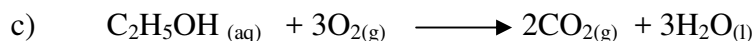

d) -Heat loss by radiation, conduction and convectional current.

-Experimental errors when reading thermometer.

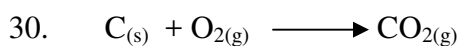

$\Delta H = -360 \text{ KJ/mole}$

1 mole of C produces 360 KJ

$\therefore 30 \text{ KJ}$ will be produced by $\frac{1 \times 30}{360} = 0.083$ moles

360

Mass of C = $0.083 \times 12 = 0.99 \text{ g}$ of C

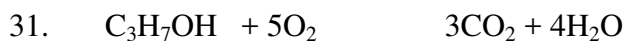

RMM for $C_3H_7OH = 60$

5g C_3H_7OH produces 167 KJ

60g C_3H_7OH will produce

$\frac{60 \times 167}{5} = 2004 \text{ kJ}$

5

Molar heat of combustion = 2004 kJ/mole

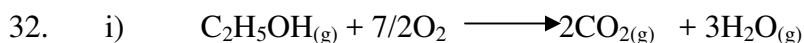

ii) Heat produced by ethanol = heat gained by water

$\Delta H = MC\Delta T$

$$500 \times 4.2 \times 60 = 126,000 \text{ J} = -126 \text{ KJ}$$

iii) RMM of $\text{C}_2\text{H}_5\text{OH} = 46$

$$\text{Moles of } \text{C}_2\text{H}_5\text{OH} = 5/46 = 0.1087 \text{ moles}$$

0.11 mole produces 126 kJ

$$\therefore 1 \text{ mole will produce } 126 \times 1 = \underline{1159.2} \text{ kJ/mole}$$

$$0.1087$$

$$\text{Molar heat of combustion} = 1159.2 \text{ kJ/mole}$$

33. Moles of $\text{CuSO}_4 = \frac{100 \times 0.1}{1000} = 0.01 \text{ Mole}$

$$1000$$

$$\text{Heat produced} = 100 \times 4.2 \times 4 = 1680$$

$$\Delta H_{\text{DI(s)}} = \frac{1680 \times 1}{0.01} = 168000 \text{ J} = 168 \text{ KJ}$$

$$0.01$$

$$\text{Molar heat of reaction} = -168 \text{ KJ/mole}$$

34.

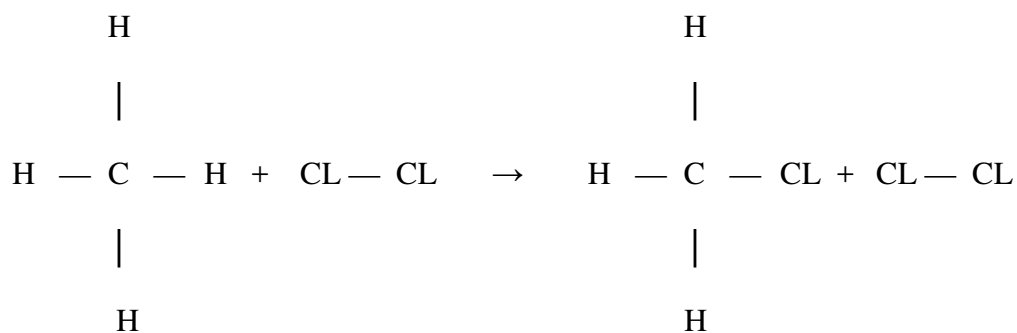

HCL

Bonds broken

$$\text{C-H} = +444$$

$$\underline{\text{Cl-Cl} + 244}$$

Bonds formed

$$\text{C-Cl} = -326$$

$$\underline{\text{H-Cl} = -431}$$

Total energy +688(E1 Total -757 (EZ)

$$\Delta H = E1 + E2$$

$$= + 688 + 758 = -70\text{KJ:}$$

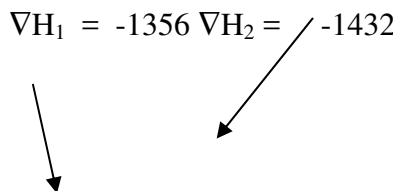
35. a) JK: The molecules gain kinetic energy vibrate more and more
b) KL: Change of state; solid naphthalene melts. The temperature remain constant.
36. i) Exothermic reaction: the products are at a lower energy level compared to the reactants.
ii) ΔH is (-ve) negative: Heat is given out/exothermic reaction.
37. i) Heat liberated when 0.25 mole of Cu is formed.
 $= -526 \times 0.25 = -131.5\text{kJ}$
ii) Heat liberated when 0.5 mole of Cu is formed $= -63 \times 0.5 = -31.5\text{KJ}$
38. $2\text{C}_{(g)} + 2\text{H}_{2(g)} \xrightarrow{\Delta H_3} \text{C}_{2(l)}\text{H}_{4(g)}$
 $\Delta H_1 = -1356$ $\Delta H_2 = -1432$

 $2\text{CO}_2 + 2\text{H}_2\text{O}$
 $\Delta H_3 = \Delta H_1 - \Delta H_2$
 $= 1346 + 1532 = + 76\text{KJ/molr}$
39. Weak acid is slightly ionized some heat is absorbed during ionization.
40. a) This is the heat change realized when one mole of a substance is formed

from its constituent elements under standard conditions.

- b) i) - Molar heat of combustion of hydrogen
 - Molar heat of formation of water vapour.

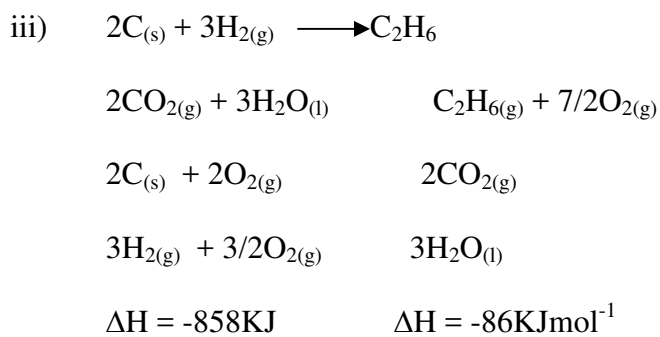
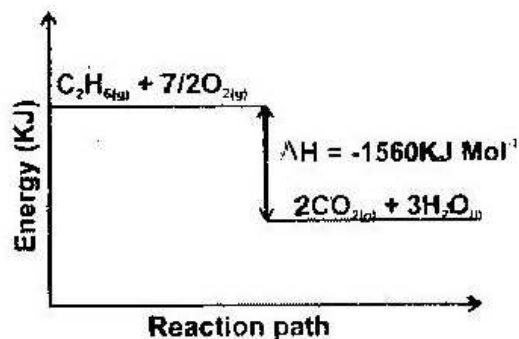
ii)



- iv) I. $E = M \times C \times O$
- $= 500g \times 4.2 \times 21.5$
- $= 45150J$
- $= 45.15KJ$
- II. $C_2H_{6(g)} + 7/2 O_{2(g)} \rightarrow 2CO_{2(g)} + 3H_2 O_{(l)}$
- $\Delta H = -156-KJmol^{-1}$
- 1560Kj produced by 30g of Ethane.
- 45.15kJ produced by 30g of Ethane.
- 45.15KJ produced by 30 x 45.5g of Ethane

1560

= 0.8683g of Ethane

TOPIC 2

RATE OF REACTION

1.
 - Effect: reaction will be faster
 - Explanation: powdered zinc offers a large surface area.
 - Heat increases the rate since particles collide more.

2.
 - a) In both cases temperature remain constant because the heat energy is being used to break up forces of attraction in the solid structure/ latent heat.
 - b)
$$\text{CdCl}_{2(s)} \rightarrow \text{Cd}^{2+}_{(l)} + 2\text{Cl}^{-}_{(l)}$$

This is because CdCl_2 is an ionic compound which is held together by electrostatic force that are stronger than vanderwaals forces and hydrogen bonds holding the H_2O molecules together. In water there is only one change (liquefaction) but in CdCl_2 there are two changes ionization and liquefaction.

3.
 - i) Curve (i)
 - ii) Concentration of F increases with time.
 - iii) After time (t) concentration does not change because equilibrium has been established.
 - ii) Manganese (IV) oxide is a catalyst and increases the rate of decomposition of the hydrogen peroxide.

4.
 - Curve (i)
 - i) Manganese (iv) oxide is a catalyst and increases the rate of decomposition of the hydrogen peroxide.

5. Use zinc powder which has a large surface area.

6.

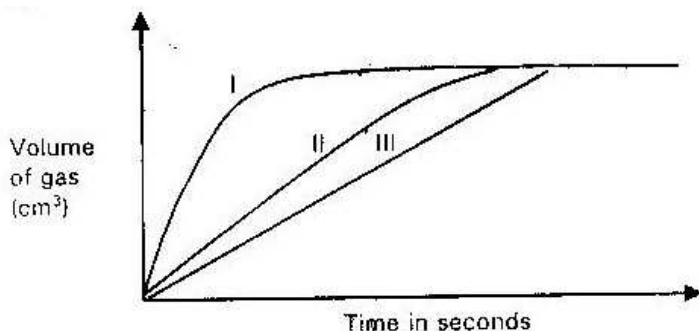

7. a) Yield would increase since ΔH is positive. Thus increase in temperature shift the equilibrium to the right.
- b) No effect; The number of molecules / volume of gases is the same both to the left and right side of reaction.
8. Increase in temperature would lower the yield of Nitrogen (ii) Oxide, this is because the reaction is exothermic and equilibrium will shift to the left.
9. Increase in pressure would shift the equilibrium to the left since increase in pressure follows the reaction which produces less volume of gas/ products/particles
10. a) The yield of ammonia could decrease.
- At high temperature ammonia decomposes
 - i.e Equilibrium moves to the left.

- b) -Manufacture of fertilizer, sodium carbonate
 - Smelling salts
 -As a refrigerants
 - Soften temporally hard water.
11. a) Gas syringe.

b)

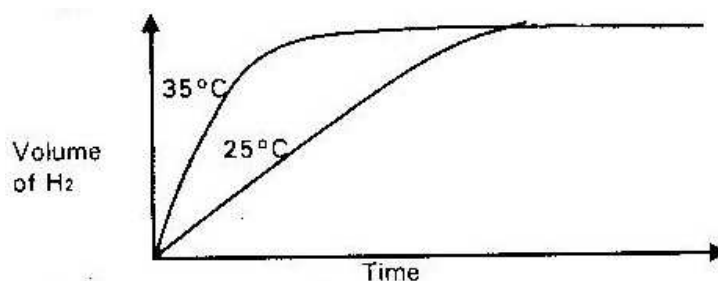

12. Equilibrium has been established or forwarded reaction equal to backward reaction.
13. a) Reaction must be carried out in a closed vessel/system
 b) Equilibrium shift to the right or forward reaction, because CO_2 will be removed from the system by potassium hydroxide.
14. Acid "M" is a strong acid than acid "L" it is fully ionized producing more (H^+) ions which react with magnesium turnings.
15. Brown solution produce; Equilibrium shift to the left so as to reduce the amount of HCL added.
16. a) Syringe barrel/graduated gas jar

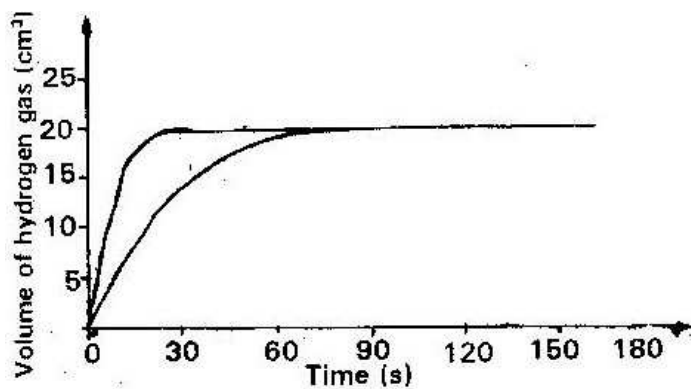

- b)i) particles gain more kinetic energy and collides very fast making reaction faster.

17 a) i)

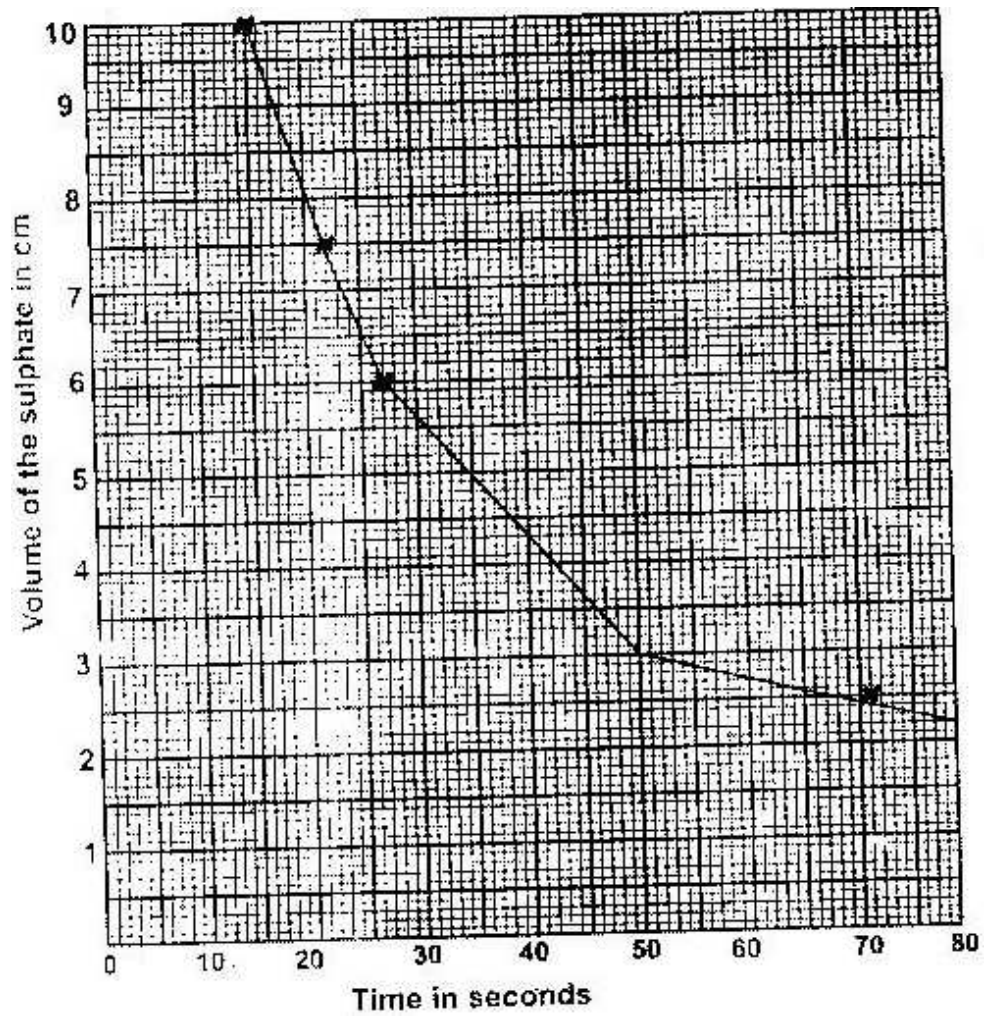

ii) I. 27 to 28 seconds/read graph

II. $28 \times 2 = 56$ seconds. The concentration of $[H^+]$ ions is half
/read graph at 3 cm^3 .

b) i) Moles of the sulphate = $\frac{10 \times 0.4}{1000} = 0.004$ moles

ii) Moles of HCL = $\frac{10 \times 2}{1000} = 0.02$ moles

iii) Thru sulphate: hydrochloric acid is in excess. (1mk)

c) Some cross should be used in each experiment.

- The cross should be viewed from the same position.

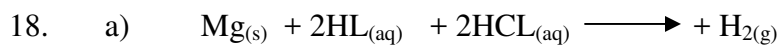

b)

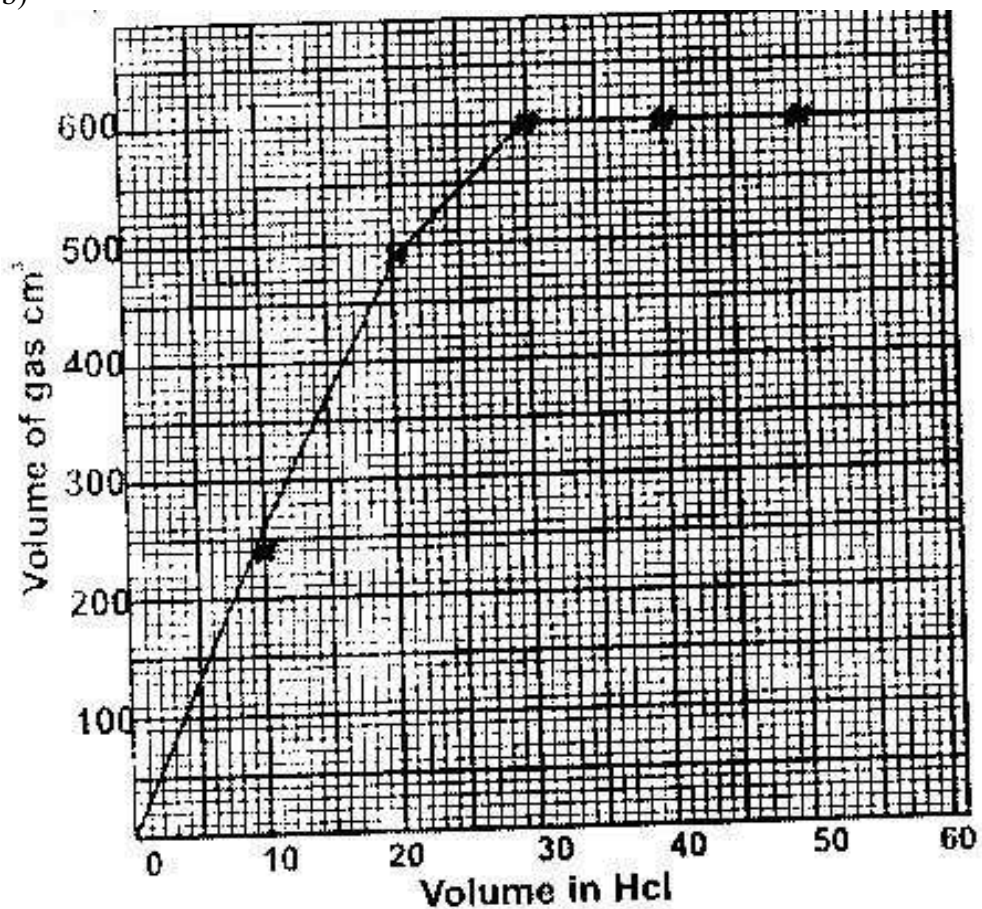

- c) a) i. 300cm^{3+}
 ii. $26.27\text{cm}^3 \pm 0.5\text{cm}^3$
- d) i) Rate is lowered, because magnesium ribbon has a small surface area then the powder/ collision between magnesium and hydrochloric acid is reduce.
- ii) Rate is increase: number of particles of HCL is higher or concentration is increased.

$$\text{Moles of H}_2 = \frac{600}{24000} = 0.025 \text{ moles}$$

$$24000$$

$$\text{Rmm mg} = \frac{0.6}{0.025} = 24$$

$$0.025$$

19. a) i)

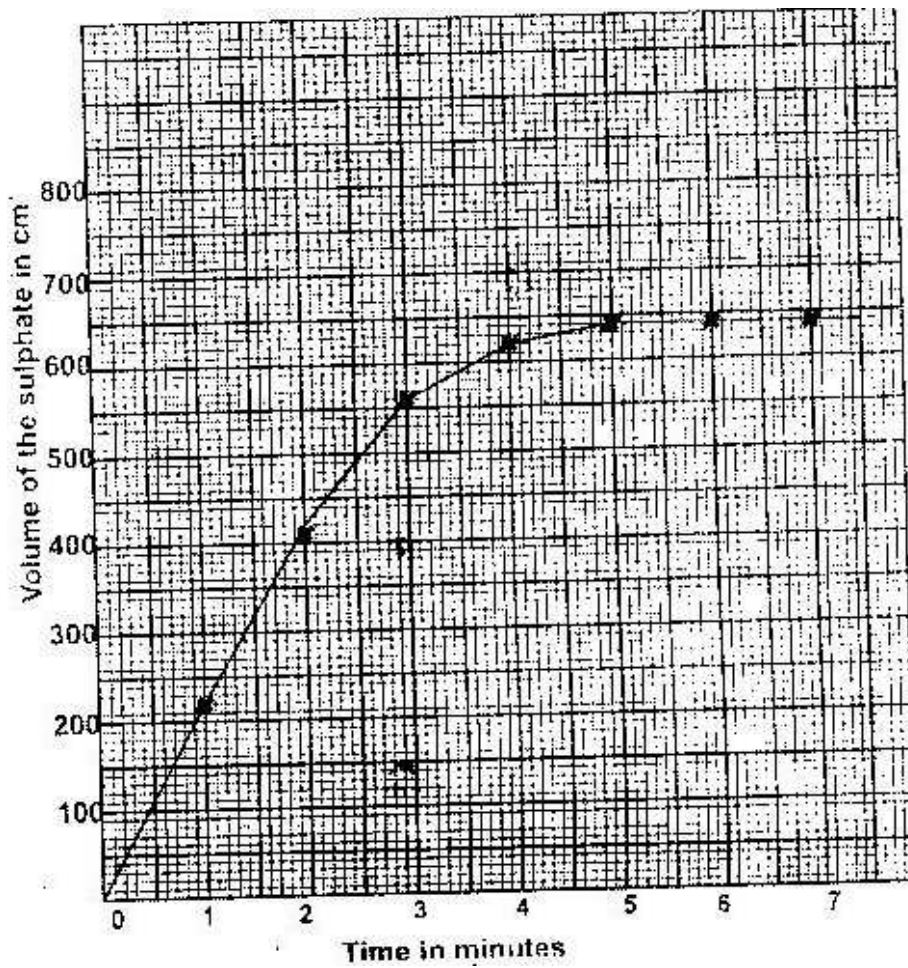

ii) $480\text{cm}^3 + 5.0\text{ cm}^3$

b) $\frac{620-540}{60} = 1.33\text{cm}^3 / \text{second}$

60

c) Solid is due to presence of copper which had not reacted. Copper is below hydrogen in the reactivity series.

d) Volume of gas H_2 from (AL)

$$= 640 - 2.5 = 637.5\text{ cm}^3$$

$$\text{Moles of } \text{H}_2 = \frac{637.5}{24,000} = 0.0266\text{moles}$$

24,000

$$\text{Moles of AL} = 0.0266 \times \frac{2}{3} = 0.0177\text{ moles}$$

$$\text{Mass of AL} = 0.0177 \times 27 = 0.4\text{g}$$

$$\text{Percentage of AL} = \frac{.48 \times 100}{0.5} = 95.6\%$$

0.5

e) -Stronger than pure aluminum

-Higher tensile strength

-Harder than aluminum/alloy

- More durable/more resistant to corrosion/ rusting.

20. a) Carbon (Iv) oxide gas was lost
- b) i. $\frac{1.8 - 0}{2 - 0} = 0.9\text{g/ minute}$
- ii. $\frac{3.2 - 2.95}{8 - 6} = 0.12\text{g/minute}$
- iii. The average rate of reaction in b(i) is higher than that in b(ii).
There are more particles between “O” and z minutes that between 6 and 8 minutes hence the frequency of collision in b(i) are higher than b(ii).
- c) $\text{CaCO}_{3(s)} + 2\text{HCL}_{(aq)} \rightarrow \text{CaCL}_{2(aq)} + \text{H}_2\text{O}_{(l)} + \text{CO}_{2(g)}$
- d) - Heating
- Increase of concentration of $\text{HCL}_{(aq)}$
- Crushing the marble chips to increase the surface area.
- e) It turns damp/wet/increase in mass. The CaCl_2 is hygroscopic. It absorbs water vapor from the atmosphere.
- f) i. Calcium sulphate.
ii. -Making plaster for building/plaster of Paris. Cement/sulphur (IV) oxide/ aluminium
-Sulphate
-As filler material for paper (white out)
21. a) Nitric acid is an oxidizing agent and will oxidize hydrogen into water and it self reduced to Nitrogen(iv) oxide and water.
- b) Reaction rate will increase since the rate of particles collision will be

higher.

c)

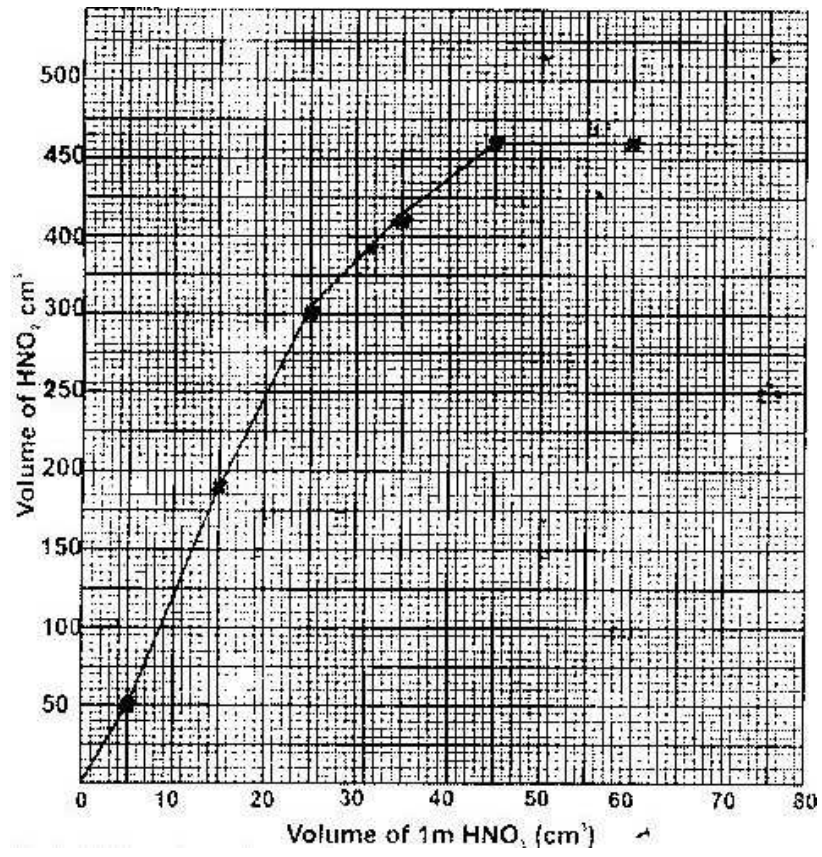

- d) i. $370\text{cm}^3 + 0.5\text{cm}^3$
 ii. $45\text{cm}^3 + 2\text{cm}^3$
- e) i. 2.07g of Pb react with 45cm^3 of 1M HNO_3
 $\therefore 2.07\text{g}$ of Pb will react with
 $207 \times 45 = 4500\text{cm}^3 \equiv 4.5\text{dm}^3$
- ii. From the graph: 45cm^3 of 1M HNO_3 produces 480cm^3 of NO_2
 $\therefore 4500\text{cm}^3$ of 1M HNO_3 produces
 $\frac{4500 \times 480}{45} = 48,000\text{cm}^3$
- f) i) Moles of nitric acid to react with one mole of Pb
 $= \frac{4,500 \times 1}{1000} = 4.5\text{m}$
- ii) Moles of NO_2 produced by one mole of Pb
 $= \frac{48000}{24000} = 2\text{mole}$
- g) $4\text{HNO}_3 + 2\text{Pb} \longrightarrow \text{Pb}(\text{NO}_3)_2 + 2\text{NO}_2 + 2\text{H}_2\text{O}$
22. a) i) forward reaction is faster than the reverse reaction.
 ii) I. Production will reduce since equilibrium will shift backward so as to raise the pressure.
 II. No change in amount of methanol since a catalyst will help reaction to come to equilibrium.
 iii) I. Negative: The reaction is exothermic since it requires low temperature to be fast.

II. To ensure that the reacting parcels possess more activation energy.

b) i) No of seconds = $2 \times 60 = 120$ sec

moles of H_2O_2 decomposed

$$= 120 \times 6.0 \times 10^{-8} = 7.20 \times 10^{-6}$$

ii) Concentration of H_2O_2 may be higher since concentration increase the rate of reaction.

23. a) i) when a stress is introduced to a system in equilibrium shifts in such a way as to minimize the effect of the stress.
- ii) No effect. There are equal number of moles on both side of the equation, therefore change of pressure does affect the equilibrium.
- iii) Negative. The forward reaction is exothermic since it is favoured by low temperature.

b) i) Manganese(IV) Oxide.

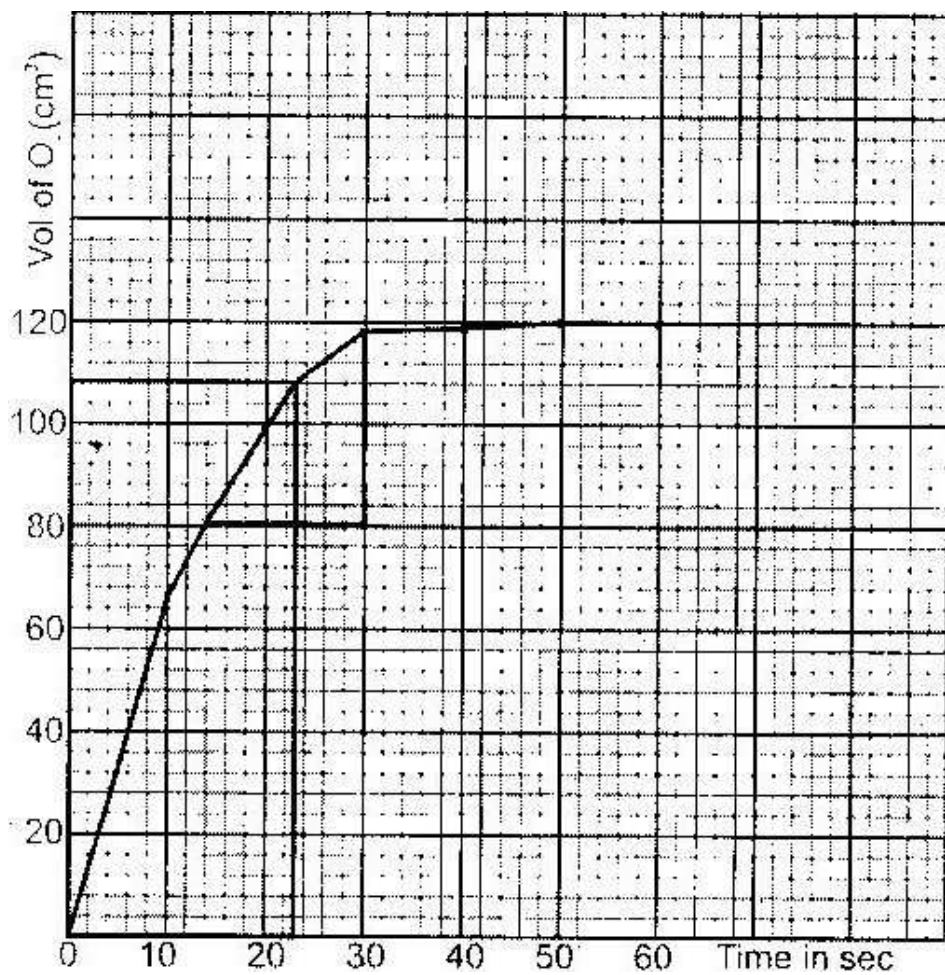

$$\text{iii) Rate of O}_2 \text{ production} = \frac{14\text{cm}^3}{10\text{sec}} = 1.4\text{cm}^3/\text{sec}$$

24. Rate of reaction indicated the velocity of chemical reaction. It is a measure of the reactants consumed of products formed per unit time.
25. - Measure a mount of product formed per unit time.
- Measure the amount of reactant consumed against time.
- Measure a mount of heat produced or consumed against time.
26. It is less reactive than hydrogen hence w is displaced by hydrogen from WO_3 .

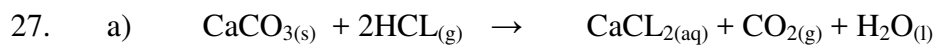

b)

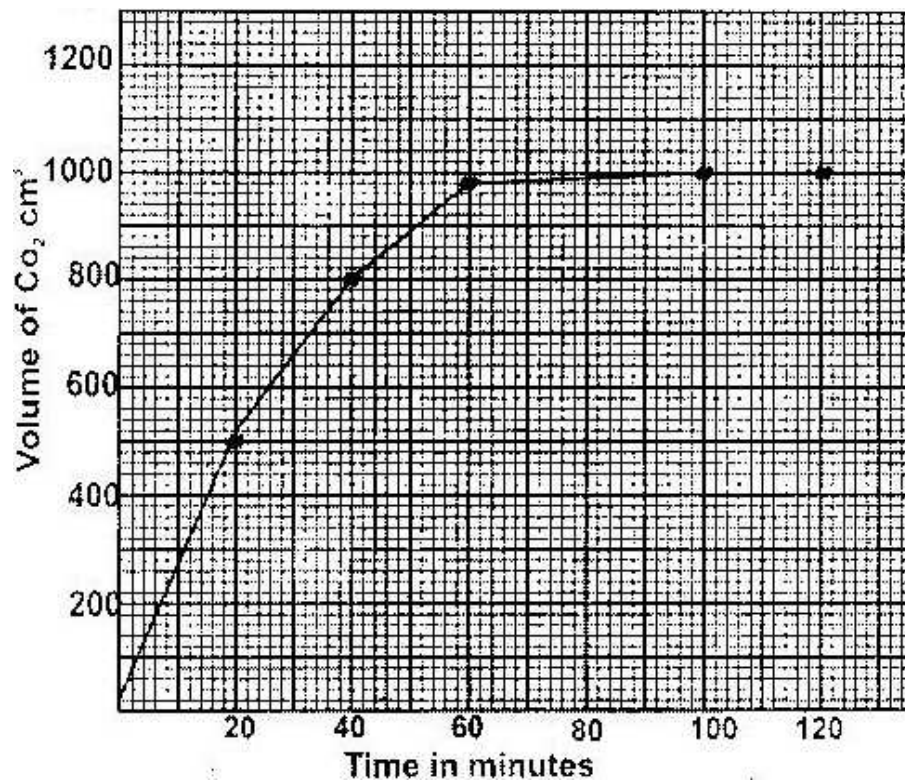

- c) $810 - 55 = 255\text{cm}^3$
- d) All the acid was used up.
- e) Moles $\text{g}_2 \text{CO}_2 = \frac{11.2}{22400} = 0.0005$

$$22400$$

$$\text{Mass of CO}_2 = 0.0005\text{moles} \times 44 = 0.022\text{g}$$

- f) Moles of $\text{g}_2 \text{CO}_2 = \frac{1020}{22400} = 0.0455$

$$\text{Moles of CaCO}_3 = 0.0455 \text{ moles}$$

$$\text{RMM CaCO}_3 = 100$$

$$\text{Mass CaCO}_3 = 0.0455 \times 100 = 4.55\text{g}$$

28. -Addition of catalyst

-Increasing the pressure.

29. i) Increase in temperature increases the kinetic energy of the particles hence

Increases the rate of collision

ii) Lowers the activation energy

b) i. Increase

ii. Increase

iii. Unaltered

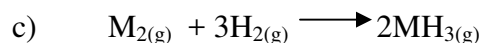

$$\Delta H = -92\text{Ks/Mole}$$

- Temperature 450° /low
- High pressure 200-400 atmosphere.
- Catalyst iron prevented with AL_2O_2 .

30. Curve (II) the reaction rate is higher because of bigger surface area.

31. Low temperature and high pressure.

32.

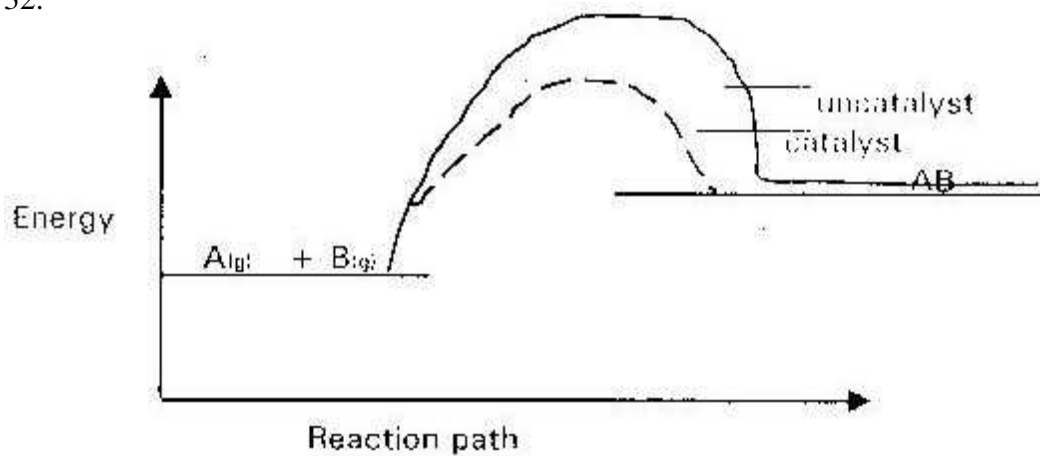

33. a) The rate of reaction is doubled.

b) The rate of reaction increases.

TOPIC 3

ELECTRO CHEMISTRY I AND II

1. a) Arrow from zinc to copper rod: zinc is more reactive than copper.
Zinc donate electrons more readily.
- b) No deflection
2. $4\text{OH}_{(\text{aq})} \rightarrow 4\text{e} + 2\text{H}_2\text{O}_{(\text{l})} + \text{O}_{2(\text{g})}$
3. i. $Q = 0.6 \times 90 \times 60 = 3240$ columbs
- ii. $\frac{3240 \times 226}{3.8} = 192695$ columbus
- iii. Charge = $\frac{192695}{96500} = 2$
Charge = +2
4. - Bulb will light since the current flow.
- Grey metal of lead form at the cathode
- Brown fumes of bromine at the anode.
5. Chloride ionizes in water since water is polar. The same chloride dissolve in methylbenzene as a molecule since the methylbenzene is non polar.
6. Cl ions will remove Pb^{2+} ions from electrolyte by farming insoluble PbCl_2
7. CL ions will remove Pb^{2+} ions from electrolyte by farming insoluble PbCl_2 .
8. a) Cathode : Hydrogen
Anode: Oxygen
- b) Increases: Since H_2O is decomposed

- c) There would be an explosion because potassium is very reactive.
9. a) $E_{\text{reduced}} - E_{\text{oxidation}} = +0.44 + 1.66 = +1.22\text{V}$
- b) Aluminum is more electropositive than Zn: hence react by losing electron ready.
10. a) Because the concentration of Cu^{+2} ions is high at the beginning and decreases as the ions are discharged during electrolysis.
- (b) $\text{Cu}^{2+}_{(\text{aq})} + 2\text{e}^{-} \longrightarrow \text{Cu}_{(\text{s})}$
11. a) $2\text{Cr}_{(\text{s})} + 3\text{Fe}^{2+}_{(\text{g})} \longrightarrow 2\text{Cr}^{3+}_{(\text{g})} + 3\text{Fe}_{(\text{s})}$
- b) $0.44 - E_{\infty} = 0.30\text{v}$
 $E_{\text{Q}} = -0.74\text{v}$
12. a) $Q = 1.5 \times 15 \times 60 = 1350 \text{ ccolumbus}$
- b) 1350c gives 0.6g $a = m$
 $3 \times 96500\text{C}$ give $\frac{0.126 \times 3 \times 96500}{1350} = 55.76$
13. $T = 32 \times 60 + 10 = 1930\text{sec}$
 $Q = 1930 \times 0.5 = 965\text{C}$
 0.44g produced by 965C
 $88\text{g} = \frac{965 \times 88}{96500} = 193000\text{C}$
 0.44
 $\text{Charge} = \frac{193000}{96500} = +2$
14. a) $\text{Ag}_{(\text{aq})} + \text{e}^{-} \longrightarrow \text{Ag}_{(\text{g})}$

- b) Anode dissolves since it is active.
15. 63.5g requires $2 \times 96500C$
- 1.48g requires $\frac{1.48 \times 2 \times 96500}{63.5} = 4498.3C$
- $Q = it \therefore 1 = \frac{Q}{T}$
- $T = (2 \times 60 \times 60) + 30 \times 60 = 9,000 \text{ sec}$
- $I = \frac{4498.3}{9000} = 0.4998A$
16. a) The colour of solution fades and Q disappears .
- Brown solid was deposited at the bottom.
- b) Metal Q is more reactive than copper, therefore it displaces copper from its solution.
17. i. Bulb did not light: No ions are present in water.
ii. Bulb light bubbles of colourless gas H_2SO_4 is an electrolyte.
18. a) No heating
b) The solid melt, the ions become mobile.
19. $Q = it = 0.82 \times 5 \times 60 \times 60 = 14760 \text{ coulomb}$
- No. of Faradays = $\frac{14760}{96500} = 0.15F$
- Moles of Z = $\frac{2.65}{50} = 0.05 \text{ moles}$
- 52
- Change of Z = $\frac{0.15}{50} = +3$

0.05

20. a) element "N" its more reactive
b) $EMF = E_{\text{reduced}} - E_{\text{oxidized}}$
 $= +0.80 + 0.76 = +1.57\text{v}$

21.

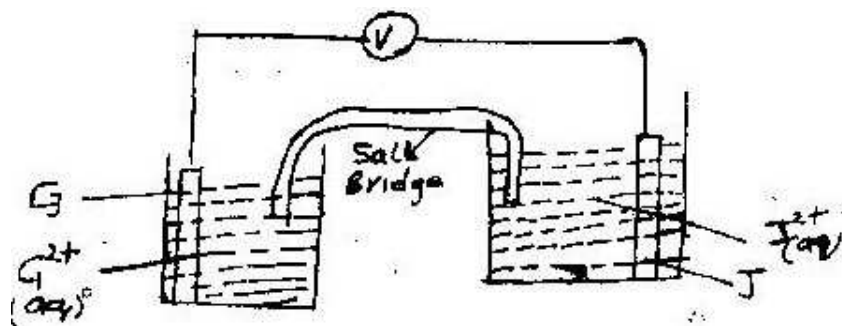

- b) $E^{\circ}_{\text{cell}} = E^{\circ}_{\text{reduced}} - E^{\circ}_{\text{oxidized}}$
 $= -0.14\text{V} - (-0.74\text{V}) = +0.6\text{V}$
22. a) Chloride ions in brime are in high concentration compare to oxide ions in solution
b) Hydrogen gas
23. a) $Ag(a) + e^{-} \rightarrow Ag(s)$
b) $Q = It = 5.0 \times 3 \times 60 \times 60 = 54000\text{C}$
Mass of silver deposited
 $= \frac{108 \times 54000}{96500} = 60.44$

24. a) $\text{Zn}_{(s)} / \text{Zn}^{2+} // 2\text{Ag}^+_{(aq)} / 2\text{A}_{(s)}$
- b) Greyish shining solid deposited round copper. Copper being more reactive displaces Ag from Ag^{2+} blue solution formed due to presence of CU^{2+} in solution.
25. a) CU^{2+} migrate toward the cathode
 CU^{2+} give solution a blue colour.
- b) $4\text{OH}_{(aq)} \longrightarrow 4e + 2\text{H}_2\text{O}_{(l)} + \text{O}_{2(g)}$
26. a) i. Copper: It is used as a standard electrode in this cell.
 The two electrodes have the same reduction potential.
- ii. "J" because it has the most negative reduction potential. Is easily oxidized.
- iii. I. $\text{K}_{(s)} \rightarrow 2e_{(aq)} + \text{K}^{+2}$
 $2m_{(aq)} + 2e \rightarrow 2M_{(s)}$
- II. By allowing ions move into the two beakers. Na^+ ions -pass into the metal M electrode beaker and NO_3 ions pass into metal K electrode beaker.
- b) i. "D" Because oxygen gas is given out at electrode "C" thus "C" is an anode
- ii. $4\text{OH}_{(aq)} \longrightarrow 4e^- + 2\text{H}_2\text{O}_{(l)} + \text{O}_{2(g)}$
- iii. I. Brown substance /solid at electrode "D" This is because CU^{2+} ions in solution gains electron at "d" to form $\text{Cu}_{(s)}$
- II. The solution will remain blue since the electrodes used are

copper and the anode will dissolve to replace the Cu^{2+} ions
which are discharged

- 27 a) i. Bauxite $\text{Al}_2\text{O}_3 \cdot 2\text{H}_2\text{O}$
ii. Iron (iii) oxide, silica
b) i.

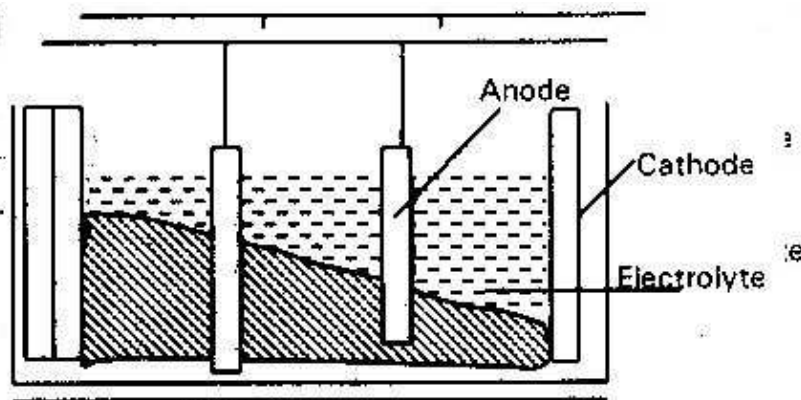

- I It is expensive / a lot of energy will be used
II. The ore is dissolve in cryolite (NaAlF_6)
III. Its melting point is less than 800°

c) $Q = 40,000 \times 60 \times 60 = 144,000,000\text{C}$

$$\text{Mass of AL} = \frac{144,000,000 \times 27}{3 \times 96500} = 13.43\text{kg}$$

28. i. C2: Hydrogen is used as a reference electrode whose E^0 value is 0.00v
ii. -240v

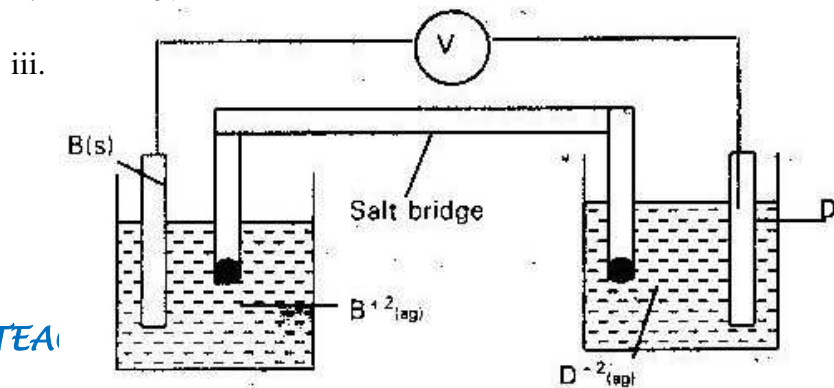

- iv. EMF E° red- E° oxidized
 $= + 2.38 + 0.34 = + 2.27\text{v}$
29. i) To lower the melting point from $800\text{-}600^{\circ}\text{C}$. Hence reduce the cost of production.
- ii) Steel will react with chlorine while graphite will not
- iii) -Its melting point is lower than that of the electrolyte
 -It is less dense than the electrolyte
- iv) To prevent the products from coming into contact
- v) i. Cathode $\text{Na}^+_{(\text{aq})} + \text{e} \rightarrow \text{Na}_{(\text{s})}$
 ii. Anode $2\text{Cl}^-_{(\text{aq})} \rightarrow 2\text{e}_{(\text{g})} + \text{Cl}_2$
- vi) -Manufacture of $\text{Na}_2\text{O}_2/\text{NaCN}$
 -Liquid sodium is used as a coolant in nuclear reactor.
 -Sodium vapour is used in street lamps
 -Extraction of metals e.g Lithium and Aluminum in termite process.
30. i) Platinum /graphite/carbon
- ii) Cation Mg^{2+} and H^+ anions SO_4^{2-} and OH^-
- iii) To the left
 I. Anode: $4\text{OH}_{(\text{aq})} \rightarrow 4\text{e} + 2\text{H}_2\text{O}_{(\text{l})} + \text{O}_{2(\text{g})}$
 II. Cathode $2\text{H}_{(\text{aq})} + 2\text{e} \rightarrow \text{H}_{2(\text{g})}$
- iv) The concentration of a aqueous magnesium sulphate increase because water molecules are broken down into hydrogen and oxygen.

31. i) I. Distilled water
 II. Titanium /platinum
- ii) Chlorine gas
- iii) - Paper industry
 - Glass industry
 - Making soap/ detergents
 - Extraction of aluminium
 - Manufacture of drugs
- b) i. I. $\text{Hg}/\text{Na}^+_{(\text{aq})} + e \longrightarrow \text{Na}/\text{Hg}_{(\text{s})}$
 II. $2\text{Na}/\text{Hg}_{(\text{s})} + 2\text{H}_2\text{O}_{(\text{l})} \longrightarrow 2\text{Na OH}_{(\text{aq})} + \text{H}_{2(\text{g})} + \text{Hg}_{(\text{s})}$
- ii. $Q=it$
 $= 100 \times 5 \times 60 \times 60 = 1,800,000\text{C}$
 1 Faraday form 1 mole of Na
 1, Mole of Na forms 1 mole NaOH
 Rmm NaOH =40
 180000C forms $40 \times \frac{1800000}{96500} = 746.1(\text{g})$
32. i) “G” it has the highest +ve potential E^0 value
- ii) $\frac{1}{2} \text{G}_{(\text{g})} + e \longrightarrow \text{G}_{(\text{aq})}$ and
 $\text{M}^+_{(\text{aq})} + e \longrightarrow \text{M}_{(\text{s})}$
- iii) Reaction can not take place from left to right “M” cannot displace
 “N” from its solution. “M” is more electropositive or the E^0 value
 is -ve

- b) i. $4\text{OH}_{(\text{aq})} \longrightarrow 4\text{e} + 2\text{H}_2\text{O}(\text{l}) + \text{O}_{2(\text{g})}$
- ii. Insert a burning split in gas jar of gas K. The gas burns with a pop sound to show it is hydrogen.
- iii. a) Hydrogen is monovalent oxygen is divalent. The same amount of electricity liberate twice as much hydrogen.
- b) The bulb is brigher with sulphuric acid. The acid is a strong acid which is fully ionized. Ethanoic acid is a weak acid partially ionized hence bulb will be dim.

33. a) E

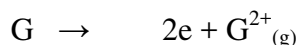
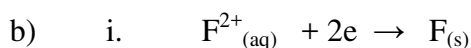

ii. $\rightarrow \text{V} \rightarrow$ From "G" to "F"

iii. -To complete the circuit

-To compensate for the ions used or added to the electrolyte.

c) i) Bluish/green blue colour of the solution fades Cu^{2+} are removed from the solution.

ii) Chlorine gas and oxygen initially the concentration of chloride ions was high hence discharged. With time the concentration of Cl^- ions decreased and $[\text{OH}^-]$ ions were discharged in preference to Cl^- ions.

iii) “J: The anions are –ve (negative) and are attracted at the anode.

34 i)

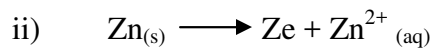
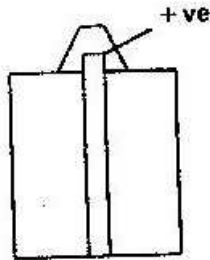

iii) The cell would not produce any current ions are not mobile since the solid is a non electrolyte.

iv) Advantage

-Portable

-Cheap

Disadvantages

- Not rechargeable

- Cannot produce continuous supply of electricity

- Causes environment pollution

b) i. Purple /violet fumes produced since iodine vapour is produced.

ii. $Q = 0.5 \times 2 \times 60 \times 60 = 3600c$

$$\text{Mass of Pb} = \frac{3600 \times 207}{2 \times 96500} = 3.86g$$

$$2 \times 96500$$

35. a) Add aqueous sodium carbonate to precipitate calcium carbonate and magnesium carbonate and filler.
- b) i. Cathode: $2\text{H}^+_{(\text{aq})} + 2\text{e} \longrightarrow \text{H}_{2(\text{g})}$
 Anode : $2\text{Cl}_{(\text{aq})} \longrightarrow 2\text{e} + \text{Cl}_{2(\text{g})}$
- ii. U I. Sodium hydroxide
 II. Graphite /platinum
 III. Sodium chloride
- iii. To prevent mixing of chlorine gas with sodium hydroxide but allow free movement of ions
- c) - In paper industries
 - Manufacture of soap/detergents
 - Making bleaching agents
 - Purification of bauxite.
36. i) G
- ii) $\text{G}_{(\text{s})} + \text{H}^{2+}_{(\text{aq})} \longrightarrow \text{G}^{2+}_{(\text{aq})} + \text{H}_{(\text{s})}$
- iii) $\text{EMF} = E^{\circ}_{\text{red}} - E^{\circ}_{\text{oxide}}$
 $+ 0.34 + 0.44 = + 0.78_{\text{v}}$
- b) i. H
- ii. Pure water does not contain ions, acid is added to make water ionize.
- iii. $\text{HCl}_{(\text{aq})}$ is not used because the chloride ions will react with the electrodes due to its high reactivity.
- c) $144750 \text{ Columbus} = \underline{144750} \text{ Faradays} = 1.5\text{F}$

96500

2 faradays gives 64g of copper

1.5 faradays give $\frac{1.5 \times 64}{2} = 48\text{g}$

2

37. i) Graphite/titanium: They do not react with chlorine.
ii) A steel diagram is suspended between the electrodes
iii) $2\text{Cl}_{(\text{aq})} \longrightarrow 2\text{Cl}_{2(\text{g})} + 2\text{e}$
- b) i. Calcium chloride
ii. It is economical /reduce cost of production
- c) Hydrogen is preferentially discharged at the expense of sodium at the cathode. At the anode OH will be discharge in expense of CL.
- d) Na_2O_2
 Na_2O
- e) -Making NaCN (Sodium cyanide used in extraction of gold).
-Making sodium lead alloy used as antiknock in petrol
-Content in nuclear reactor.
38. a) Substance which when molten fused or in aqueous solution conduct electricity and is decomposed.
b) i. Conduct electricity when solution through the flow of the ions.
ii. Graphite has a delocalized electrons which conduct electricity.
c) ← Electron flow

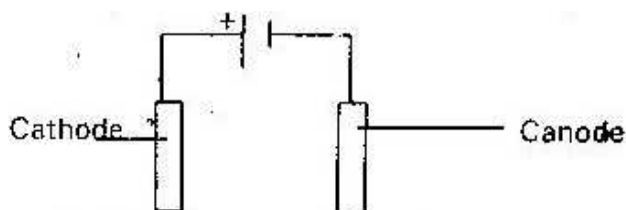

ii. Syringe 1: H⁺ ions are positively charged and are discharged at the cathode.

a) During the process the water molecules are decomposed to give hydrogen and water.

b) $Q = 0.72 \times 15 \times 60 = 648$ Columbs

1 mole of gas (O₂) requires 4 faraday i.e

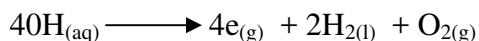

680 Columbus will liberate $\frac{648 \times 1}{4 \times 96500} = 0.001679$ moles

$$4 \times 96500$$

Volume of O₂ = 2400 x 0.001679

$$= 40.29\text{cm}^3$$

39. a) (i) both SO₄²⁻ and OH migrate to the anode. OH being lower on the electrochemical series is preferentially discharged by losing electrons to form water and oxygen.

ii) The anode would dissolve in water and move to the cathode as copper(II) ions. This would discharge the products of the electrolysis.

b) i) - Copper pyrites

- Copper iron disulphide

- Basic copper carbonate

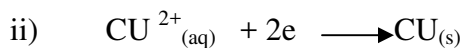

iii) $Q = It = 0.5 \times 18 \times 60 = 540\text{C}$

96000C deposit 108g of Ag

540C deposit $\frac{108}{96000} \times 540\text{g}$ of Ag

96500

iv) - To prevent rusting/ corrosion

- For beauty

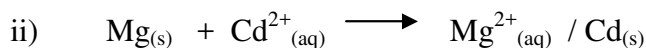
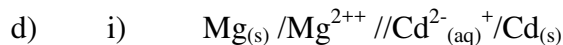
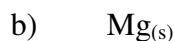
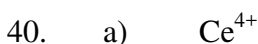

iii) E value = E^0 oxidized

$$= -0.402 + 2.37 = +1.968\text{V}$$

41. a) i) The bulb does not light since solid bromide is a non electrolyte

ii) Solid Lead (II) Bromide does not contain free ions

b) To provide mobile ions

c) Anode: Brown gas evolved (Br_2)

Cathode: Grey solid (Pb) deposited

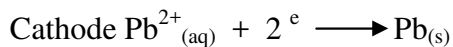
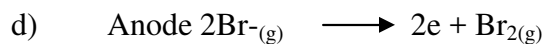

42. i) Hydrogen ions are discharged in preference to potassium ion. H^+ are below potassium in the preferential discharge series.

ii) Iodine is given off as a dark brown violet vapour.

iii) $Q = 0.2 \times 5788 = 1157.6$ coulombs

0.208 g of or requires 1157.6 coulombs

$\therefore 52g = Cr$ requires $\frac{52 \times 1157.6}{2} = 289400$ coulombs

0.208

Change of Cr = $\frac{289400}{2} = +3$

96500

43. $Emf = E^{(-)} \text{ produced} - E^{(-)} \text{ oxidized}$

$$= -0.40 + 1.19 = + 0.79 \text{ V}$$

44. $Zn_{(s)} + 2 Fe^{3+}_{(aq)} \longrightarrow Zn^{2+} + 2 Fe^{2+}_{(aq)}$

45. $EQ \text{ value} = E^0 \text{ reduced} - E^0 \text{ oxidized}$

$$= + 1.36 + 0.76 = + 2.12 \text{ V}$$

46. a) Current flow

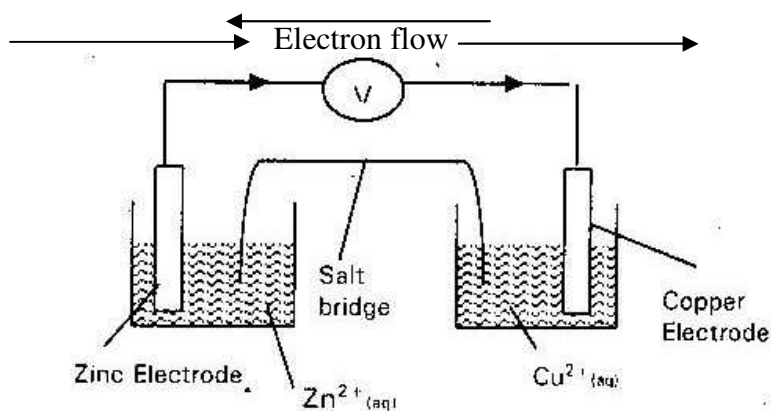

b) $\longrightarrow \longrightarrow$ Electron flow

$\longleftarrow \longleftarrow$ Current flow

c) (see diagram)

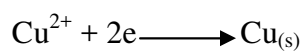

f) 2 moles of electrons

g) $2 \times 96500 = 193000$ Coulombs

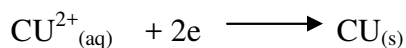
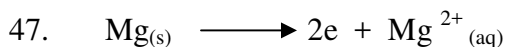

48. a) i) Oxygen gas evolved at anode Hydrogen gas evolved at the cathode
 OH^- and H^+ ions are discharged in preference of Na^+ ions SO_4^{2-} ions.

ii. Chlorine liberated at anode sodium discharged at the cathode to form sodium Amalgam. There is high concentration of Chloride ions in Brine.

High over voltage effect at the mercury cathode by hydrogen. This sodium is discharged instead of Hydrogen. The resulting solution is an alkali.

b) i) Copper ions were discharged and at the same time, the copper anode dissolves to form Copper (II) ions.

ii) To increase the concentration of OH ions (II) ions.

iii) Copper

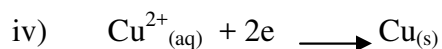

v) $Q = it = 1.5 \times 600 = 900 \text{ C}$

900 C gives 0.296g of = Cu

Hence 63.5 g of Cu produced by

$$\frac{63.5 \times 900}{0.296} = 193074 \text{ C}$$

0.296

$$\text{Farady constant} = \frac{193074}{2} = 96537 \text{ C}$$

2

49. $E.M.F = E^0_{\text{Reduced}} - E^0_{\text{Oxidised}}$

$$= + 1.36 + 2.38 = + 3.74 \text{ v}$$

TOPIC 4

METALS

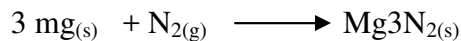
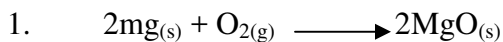

b) silver white / grey metallic deposit of Lead

c) Hydrogen gas / ammonia gas

3. a) Electrolysis of fused or molten oxide

b) J- Carbon – H

4. a) Heat

b) i) D= Sulphur (IV) oxide

ii) - Battery casing

- Galvanising ion

- Electroplating

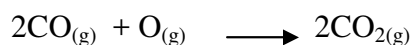
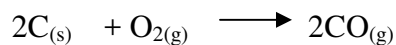
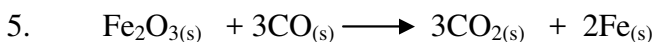

6. a) Reduction

b) - Oxidation state of Pb in PbO is reduced from +2 to 0 (zero)

- Removal of oxygen

c) Ammonia gas / Hydrogen gas

7. Coke: to reduce PbO to Pb

Limestone: to remove silica as slag

Scrap iron: To reduce unleaded Pbs to pb

8. a) dilute Nitric Acid
b) Silver metal
c) Oxygen
9. a) Froth floatation
b) $\text{ZnCO}_3 \longrightarrow \text{ZnO}_{(s)} + \text{CO}_2_{(g)}$
c) Manufacture of dry cells. Zinc casing forms the anode of dry cells.
10. a) i) Cryolite NaAlF_6
ii) Electrolysis
b) - Good conductor of heat
- Resistant to corrosion
- High melting point
- Malleable
11. i) sulphuric (IV) oxide
ii) $2\text{CuFeS}_2_{(s)} + 4\text{O}_2_{(s)} \longrightarrow 2\text{FeO}_{(s)} + 3\text{SO}_{(s)} + 3\text{SO}_2 + \text{Cu}_2\text{S}_{(s)}$
iii) Fe^{3+}
iv) Carbon (II) Oxide or Carbon (IV) Oxide
v) Redox or reduction & oxidation because Cu_2O is reduced to $\text{Cu}_{(s)}$ and CO oxidized to CO_2

b)

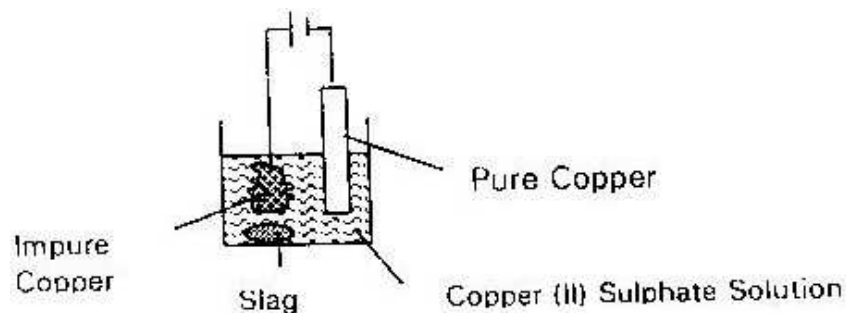

c) Moles of Cu = $\frac{210}{63.5} = 3.3$ moles

Rmm of $\text{CuFeS}_2 = 183.5$

Moles of $\text{CuFeS}_2 \equiv 3.3$ mole

Mass of pure ore = 3.3 mole

Mass of pure ore = $3.3 \times 183.5 = 605.5$ kg

% purity = $\frac{605.5}{810} \times 100 = 74.85$

810

- d)
- Formation of acidic rain due to SO_2
 - Sulphur ((IV) oxide is poisonous
 - Carbon (II) oxide is poisonous
 - Green house effect due to CO_2
 - Dumping of waste like slag prevents growth of plants.
 - Soil erosion due to extraction of ores from the ground

12. a) i) Galena /pbs

- ii) Some of the sulphide is converted into oxide (PbO or SO₂)
 - iii) Carbon (II) oxide or carbon (IV) Oxide
 - iv) $PbO + C_{(s)} \rightarrow Pb_{(s)} + CO_{(g)}$
 - v)
 - SO_{2(g)} is poisonous
 - SO₂ causes acid rain
 - CO_(g) poisonous
 - Pb / Pb²⁺ is poisonous / affect the nervous system.
 - vi) To reduce the unreacted PbS to Pb Lead
- b) Hard water contains Ca²⁺ and Mg²⁺. These ions form a protective layer of CaCO_{3(s)} on the lead. This prevents Lead from dissolving hence no Lead poisoning. Soft does not form these deposits.
- c)
 - Radioactive shielding
 - Lead/acid accumulators
 - Making alloy soldering wire
 - Making of anti-knock additive
 - Manufacture of paint
 - Manufacture of bullets
 - Manufacture of ball bearings.
13. a) Electrolysis /Hall / Hertyoult cell
- b) Al₂O₃: 2H₂O
- c)
 - i) Iron (III) Oxide /Silica
 - ii) Add hot concentrated NaOH_(aq) /KOH_(aq) silica and Al₂O₃ oxide dissolves.

Carbon (IV) oxide then add water and finally add Al(OH)_3 to the filtrate to precipitate $\text{Al(OH)}_{3(s)}$. Filter the $\text{Al(OH)}_{3(s)}$ and Silica will remain in the solution.

- d) To lower the melting of Aluminium oxide from 2015 to 850°C / also act as an electrolyte.
- e) Oxygen gas produced at the graphite anode. Carbon anode react with the oxygen to form Carbon (IV) Oxide.
- f) Aluminium react with Oxygen to form Aluminium oxide which protect aluminium from further corrosion.
- 14 a) i) Calcium silicate/Calcium aluminate
- ii) - Magnetite Fe_3O_4
- Siderite FeCO_3
- Pyrite FeS
- iii) Carbon (IV) Oxide
- b) Hot compressed air oxidizes coke CO_2
- $$\text{C}_{(g)} + \text{O}_{2(g)} \longrightarrow \text{CO}_{2(g)}$$
- $$\text{CO}_{2(g)} + \text{C}_{(s)} \longrightarrow 2\text{CO}_{(g)}$$
- Co / Carbon (II) Oxide reduces Fe_2O_3 to (iron)
- $$3\text{CO}_{2(g)} + \text{Fe}_2\text{O}_{3(s)} \longrightarrow 2\text{Fe}_{(s)} + 3\text{CO}_{2(g)}$$
- c) Decompose to give CaO / calcium oxide which combine with silica and Aluminium oxides/ impurities to remove them as slag.
- d) It contains many impurities such as carbon, and manganese.
- e) - Construction of bridges/ ship/ buildings

- Car bodies, nail, railway lines pipes, spoons, pressure cookers.
- Horse shoe magnet.

15. a) i) - Effervescence and brownish gas produced.

- Blue solution formed

ii) Dilute HCL is not an oxidizing agent.

iii) I. $\text{Cu}_{(s)} + 4\text{HNO}_{3(aq)} \longrightarrow \text{Cu}(\text{NO}_3)_{4(aq)} + 2\text{NO}_{2(g)} + 2\text{H}_2\text{O}_{(l)}$

II. Moles of CU = $\frac{0.5}{63.5} = 0.007874$

63.5

Moles of HNO₃ = 0.007874 x 4 = 0.31496

Volume of HNO₃ = $\frac{0.00314 \times 1000}{10} = 10.49\text{cm}^3$

3

b) Step 4: Neutralization

Step 5: Displacement

c) - Resistant to corrosion

- It is tough, / strong metal

16. i) Extraction of Aluminium

ii) Adding hot half concentrated sodium Hydroxide,

iii) To melt it, so so as to make the ions mobile/make it an electrolyte.

iv) Al₂O₃ as a stable ions compound which can only be reduced by electrolysis. Aluminium is more reactive than carbon.

v) -Light metal

-Strong and durable

-Not easily corroded

17. i) I) Carbon (II) Oxide / Carbon (IV) Oxide
 II) Dilute Sulphuric acid

Chamber I

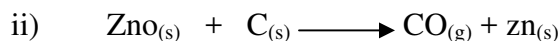

Roaster

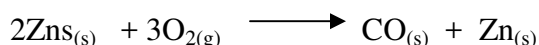

Chamber II

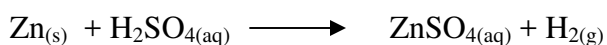

iii) I: Mass of zns = $\frac{45 \times 250}{100} = 112.5\text{g}$

$$100$$

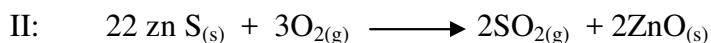

Moles of ZnS = $\frac{112.5}{97.4} = 1.16 \text{ moles}$

$$97.4$$

Volume of SO₂ ≡ 1.16 Moles

Volume of So₂ = 1.16 x 24 = 24.72 dm³

b) - Cause acidic rain

- SO₂ is poisonous

c) Contact process: SO₂ (by product) can be used to manufacture sulphuric

18. i) Sulphur

ii) Sulphur (IV) oxide

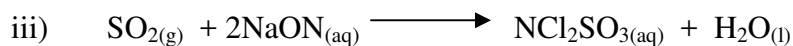

19. i) Physical change: because there is no change in mass of iron (III) oxide.

- ii) Iron is more electropositive than hydrogen and less than carbon.
 - iii) Hydrogen gas
 - b)
 - i) Hydrated iron (III) oxide
 - ii) Aluminium form a coating of an oxide (Al_2O_3) which prevent further corrosion.
 - iii) Zinc is more reactive than iron so it loses it's electrons more easily than iron. Hence zinc corrode before iron.
20. They are in the same group.
21. A
22. -Resistant to corrosion
-Light metal
23. a) "M" b) "L"
24. a) Dissolve the ore in Nitric acid. To the filtrate add sodium Hydroxide dropwise till in excess; Brown / iron(III) ions (Fe^{3+} or add Ammodia solution till in excess again to obtain reddish brown precipitate of iron (III) ions Fe^{3+} .
- b) i) Mass of iron Oxide

$$= 13.30 - 10.98 = 2.32g$$
 Mass of iron/residue = $12.66 - 10.98 = 2.32 g$
 Mass of oxygen = $2.32 - 1.68 = 0.64g$

Elements	Fe	O
Mass	1.68	0.64
Moles	$\frac{1.68}{56} = 0.03$	$\frac{0.64}{16} = 0.04$
Ratio	$\frac{0.03}{0.03} = 1$	$\frac{0.04}{0.03} = 1.3$
X	3	4

$$(\text{Fe}_3\text{O}_4)_n = 232$$

$$(232)_n = 232: n = 1 \text{ MF} = \text{Fe}_3\text{O}_4$$

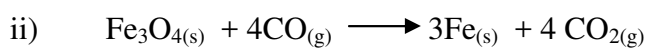

- c) i) - Moisture
- Oxygen
- ii) - Galvanising
- Painting/greasing
- Plastic coating
- Alloying

d) Salt accelerate the rate of rusting /corrosion

25. Sodium atom has a large atomic radius and losses electrons very easily compared to Lithium which has a small atomic radius/Lithium outer most electrons are strongly attracted by the nucleus protons hence not easily removed.

TOPIC 5

ORGANIC CHEMISTRY 2

1. The ionic “head” lowers the surface tension of water facilitating mixing of water and grease. The non polar “tail” mix with grease, dislodging it from the fabric.

2.

Name of polymer	Name of monomer	Use of polymer
Polystyrene	Styrene Phenylene	Insulation, plastic pipes, biros, artificial rubber
Polyvinyl Chloride Polychloro Ethane	Vinyl chloride Chloroethene	Insulation of electric cables plastics tanks

3. “B”: “B” does not form scum

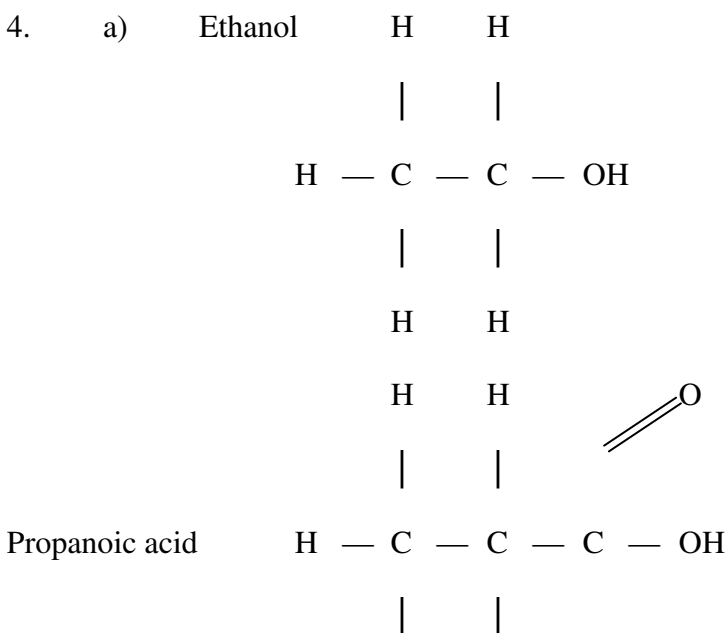

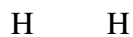

- b) Alkanols / alcohols
5. a) Perspex/polymethyl/methacrylate
- b) As a substitute for glass in manufacture of
- Safety screen
 - Plastic lens
 - Wind screens
6. a)
- $$\begin{array}{cccc}
 \text{H} & \text{H} & \text{H} & \text{H} \\
 | & | & | & | \\
 \text{H} - \text{C} & - \text{C} & - \text{C} & - \text{C} - \text{OH} \\
 | & | & | & | \\
 \text{H} & \text{H} & \text{H} & \text{H}
 \end{array}$$
- b) Alkanols/alcohols
- c) $2\text{C}_4\text{H}_9\text{OH}_{(l)} + 2\text{K}_{(s)} \longrightarrow 2\text{C}_4\text{H}_9\text{OK}_{(s)} + \text{H}_{2(g)}$
7. There is a constant increase in mass caused by constant addition of $-\text{CH}_2$
8. a) N - Sodium ethanoate/ $\text{CH}_3\text{COO Na}$ /sodium acetate.
- P - Methane/ CH_4
- (b) Substitution
9. Esterification
10. Penten -1-al is polar. There are two forces, vanderwaals and hydrogen bonds holding its molecule together. Pentane is none polar.
11. a) $\text{CH}_3(\text{CH}_2)_{12} \text{COONa}$

- b) Soapy detergent
- c) $(\text{CH}_3(\text{CH}_2)_{12}\text{COO})_2\text{Ca}/(\text{CH}_3(\text{CH}_2)_{12}\text{COO})_{2\text{mg}}$
12. Butanoic acid and propanaol
13. i) Pentanoic acid
- ii) $\text{C}_3\text{H}_6\text{O}$
- iii)

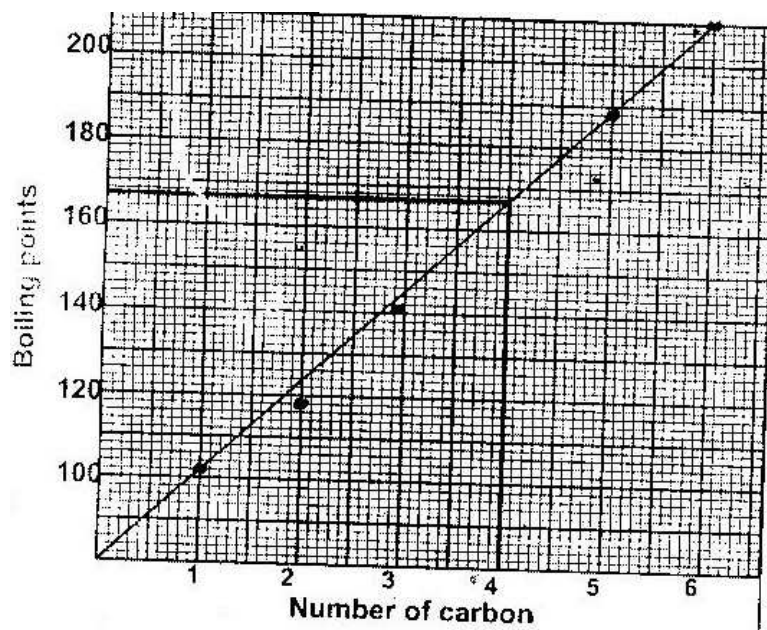

I. $166 \pm 0.6^\circ\text{C}$

iv) The boiling point increases with increase in mass. The molecular mass increase by $-\text{CH}_2$ Unit (14 units) this causes an increase in intermolecular forces between molecules. Hence more heat is required to break the bonds in complex molecules.

b) Effervescence /colourless gas is given off. This is CO_2 and it forms white precipitate with lime water.

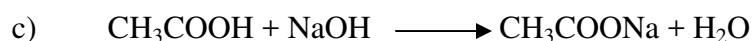

$$\text{Moles of CH}_3\text{COOH} = \frac{30}{60} = 0.05 \text{ moles}$$

$$\text{Moles of NaOH} = 0.05 \text{ moles}$$

$$\text{Volume of Naoh} = \frac{0.05 \times 1000}{0.2} = 250\text{cm}^3$$

14. a) Polystyrene/polythene
 b) Cause pollution since it is non biodegradable.

15. a) i) propanoic acid

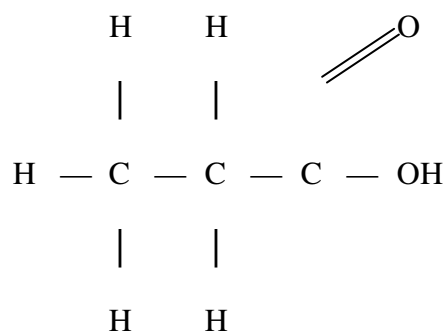

- ii) Ester

b) The colour of solution changes from orange/yellow to green because Cr^{+6} is reduced to reduced to Cr^{3+} and ethanol is oxidized to ethanoic acid.

- c) i) Soap/soapy detergent
 ii) Sodium chloride
 iii) To make soap float
 iv) Potassium hydroxide/KOH
 v) A molecule of cleansing agent has polar and non polar parts. Non polar parts dissolves in oil and polar parts dissolves in water.
 When the mixture is agitated the oil droplets coagulate and can be washed away with water.
16. a) i) CH_3OH
 ii) CH_3COOH
- b) $\text{HCOOH}_{(\text{aq})} + \text{NaOH}_{(\text{aq})} \longrightarrow \text{HCOONa}_{(\text{aq})} + \text{H}_2\text{O}_{(\text{l})}$
- c) i) Methyl methanoate / HCOOCH_3
 ii) -Heat
 -Concentrated sulphuric acid
- d) i) Use of bromine water or acidified potassium manganate (VII).
 Hexane decolourises both at room temperature but hexane does not.
- ii) -Fuel
 -Solvent
 -Manufacture of Hexanol and Hexanoic acid.
- iii) $\text{C}_6\text{H}_{12} + \text{H}_2 \longrightarrow \text{C}_6\text{H}_{14}$
 Rmm of $\text{C}_6\text{H}_{12} = 84$
 Moles of $\text{C}_6\text{H}_2 = \frac{42}{84} = 0.5$ moles

Moles of $H_2 = 0.5$ moles

Volume = $0.5 \times 22.4 = 11.2 \text{ dm}^3$

17. i) I: Oxidation
 II: B = ethane
 C = sodium ethanoate
- ii) To bring the reacting monomers into close contact.

- iv) -As a fuel
 -In making carbon black
 -Manufacture of methanol
 -Manufacture of hydrogen cyanide

18. a) i) I: V_1 and V_3
 II: V_2 and V_5
- ii) V_4 : It is unsaturated compound and during polymerization the double bond is broken to allow another monomer to combine.

b)

	Advantage	Disadvantage
R-COO ⁻ Na ⁺	They are biogradable do not cause pollution	Forms scum with Ca ²⁺ and Mg ²⁺
R-OSO ₃ Na	They do not form scum with Ca ²⁺ and Mg ²⁺ (aq)	They pollute the environment since they are non biogradable.

- c) i) Ester
 ii) $CH_3COOC_2H_3$

- iii) -Used as solvent
- Manufacture of drugs and chemicals
- In flavouring and preservation of food
- In manufacture of synthetic fibres

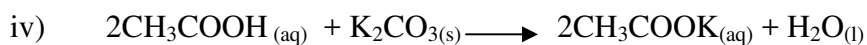

- d) i) Natural fibres include
Rubber, Cellulose, Wool, starch, silk
 - ii) Advantages of synthetic fibres.
 - Can be made into complicated shapes more easily.
 - Less expensive
 - Resistant to corrosion
 - Less dense and stronger
19. a) i) Change from orange to green.
- ii) Effervescence and a colourless gas which burn with a “Pop” sound Produced.

- b) Step I: Fermentation: Glucose solution is mixed with yeast. The Enzymes from yeast convert glucose to ethanol.
- Step II: fermentation: Dehydration: Ethanol is mixed with concentrated sulphuric acid and heated in presence of Al_2O_3 as a catalyst.

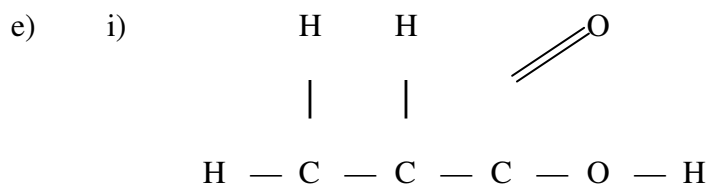

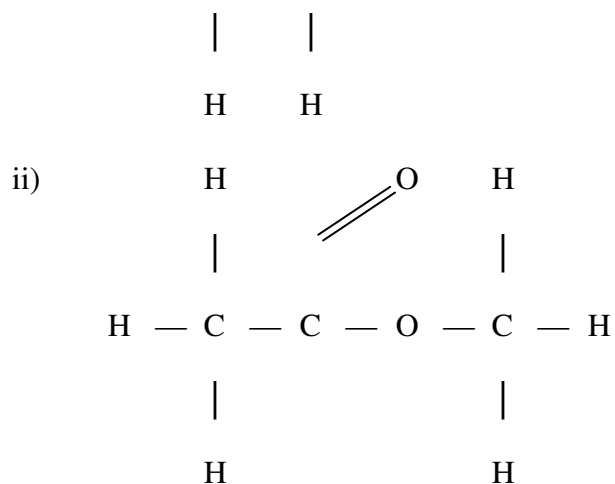

- f) -Produces acidic – compounds which causes Global warming
 -Produces acidic compounds which causes acidic rain.

20 a)

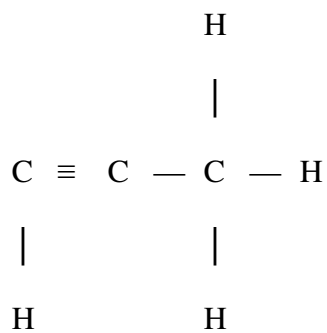

- b) i) -High temperature (700⁰C) or
 -Produces acidic – compounds which causes acidic rain.
- ii) Ethane / C₂H₆
- iii) I. Polluting the environment / they are non biodegradable
 II. Hydrolysis
 III. Ethypropanoate

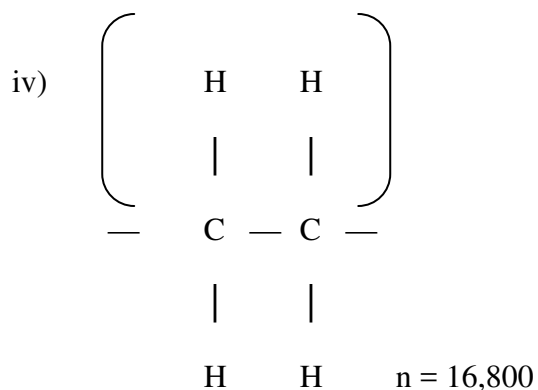

$$\text{Monomer} = \frac{16800}{28} = 600 \text{ monomers}$$

28

- c) i) "M" it is unsaturated with a double bond. Its an alkene.
 ii) "N" It is an organic acid and will react with carbonate to give CO₂.
21. i) Monomers of carbohydrates
 ii) Condensation in which a molecule of water is eliminated between two monosacchararide.
22. i) Amino acids/ proteins
 ii) The carbon chain is linear
 iii) -Ester and water
 -Condition is -heat
 -Concentrated sulphuric acid/catalyst
23. i) $\text{ClCH}_2\text{COOH}_{(\text{aq})} + \text{KOH}_{(\text{aq})} \text{ ---- } \text{ClCH}_2\text{CH}_2\text{COOK}_{(\text{aq})} + \text{H}_2\text{O}_{(\text{l})}$
 ii) Molarity = $2.635 \times \frac{1000}{25} = 0.969 \text{ moles/dm}^3$
 250
 iii) Moles of KOH = $\frac{25 \times 0.1}{250} = 0.0025$
 250

- iv) Moles of acid = 0.0025 since ratio is 1:1
24. i) I: -Concentrated sulphuric acid
 -Heat
 II: Excess acidified potassium manganate (VI)manganate (VII)
 III: Sodium metal
 IV: -Sulphuric acid
 -Ethanoic acid
- ii) -Textile /clothing
 -To make ropes
 -Safety bolts
 -Lents
 -Sails
- d) i) -Rubber
 -Cellulose, Wool, silk, Starch, Protein
 ii) Heating rubber with sulphur so as to make it strong hard and tough
- e) i)
$$\begin{array}{c} \text{CH}_3 \\ | \\ \text{CH}_2 = \text{C} - \text{CH} = \text{CH}_2 \end{array}$$
- ii) 2, methyl but -1, 3 - diene
25.
$$\text{CH}_3\text{CH}_2\text{OH}_{(l)} \xrightarrow[170^\circ\text{C}]{\text{Conc H}_2\text{SO}_4} \text{CH}_2 = \text{CH}_{2(g)} + \text{H}_2\text{O}_{(l)}$$
26. i) C ii) B

27. Ethanoic acid (CH_3COOH) reacts with sodium Carbonate to liberate Carbon (IV) Oxide while Ethanoic does not.
28. a) Reagent : Hydrogen gas
Conditions : Heat
Nickel catalyst
- b) Catalytic cracking using asbestos as a catalyst and heat
- c) -Ozonised oxygen at 00C
-Water
-Acidified potassium Dichromate
29. a) A substance that improve the cleasing power of water.
Advantages
- b) -Forms lather easily in both soft and hard water
-Not alkaline or acidic
Disadvantaged
- Non biodegradable
 - Environmental pollution
 - Eutrophication in water.
- c) Polar end ($\text{C}=\text{O}$) dissolves in water to form micable. Non polar end (CH_2) attract the greese /dirt. The greese is then carried off while attracted to the non polar end linked to water to the polar end as a co agulant.
- d) To avoid scum formation in hand water by complexing with calcium and magnesium ions.

- e) Add a little fat/oil to aqueous Sodium Hydroxide and boil for some time.
Add saturated sodium, Chloride to precipitate out soap (salting out) filter
and dry to obtainin solid soap which can then be made into flakes.

TOPIC 6

RADIOACTIVITY

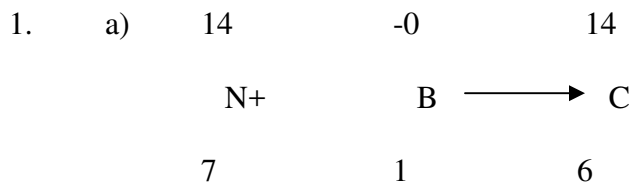

- b) - Nuclear reactor
- Atomic bombs
- Detecting leakage
- Studying photosynthesis
- Security measurement
- Treatment of cancer
- Sterilize surgical instruments
- Dating
- Killing bacteria

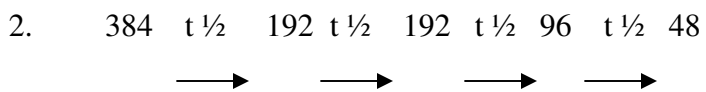

$$4t_{1/2} = 270$$

$$T_{1/2} = \frac{270}{4} = 67.5 \text{ days}$$

3



$$3t_{1/2} = 81$$

$$T_{1/2} = \frac{81}{3} = 27 \text{ days}$$

- b) Mass number 233
Atomic number 92

4.

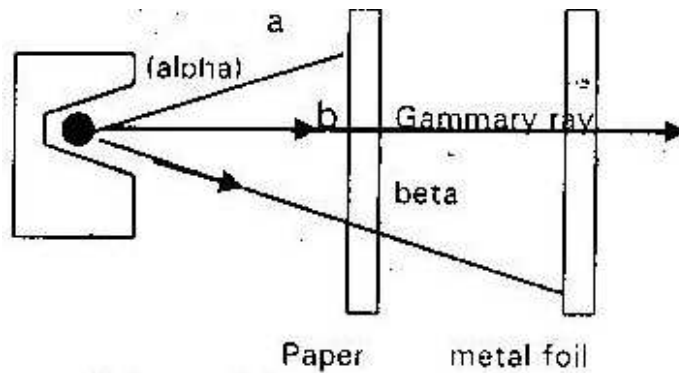

a = Alpha particle

b = Gamma Ray

c = Beta particles

5. a. Time taken for a given mass of radioactive isotope to reduce to half.

b. $\frac{100}{25} = 4$ half lives

25

80 ← 40 ← 20 ← 10 ← 5

Original mass = 80g

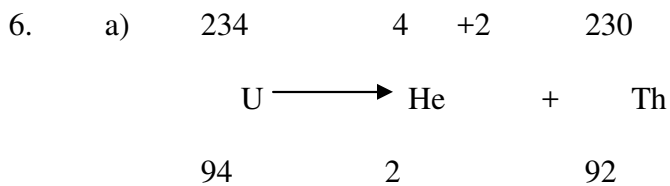

- b) Some rays e.g gamma will penetrate through aluminium and may cause

the biological damage to the organisms.

7. a) $t_{1/2} = 8 \pm 0.5$ day

b) $10 \rightarrow 5 \quad 2.5 \rightarrow 1.25 \rightarrow 0.625$

$$\frac{32}{6}$$

$$6$$

$$\text{Mass remaining} = 0.625\text{g}$$

8. a) 222

$$X$$

$$86$$

b) $1 \rightarrow \frac{1}{2} \rightarrow \frac{1}{4} \rightarrow \frac{1}{8} \rightarrow \frac{1}{16}$

$$4t_{1/2} = 112$$

$$T_{1/2} = \frac{112}{4} = 28 \text{ days}$$

$$4$$

9. a) Atoms of the same element which have the same atomic number but different mass numbers.

$$0 \quad 14$$

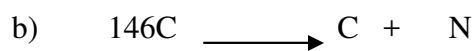

$$7$$

c) -Dating young fossils

-Isotopic tracer

-tracking of biological process

10. a) Alpha

b) ${}_{82}^{210} \quad {}_{82}^{210} \quad 0$

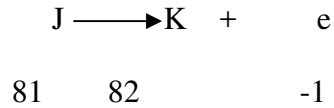

- c) "K" and "M"
11. a) $100 \xrightarrow{T_{1/2}} 50 \xrightarrow{T_{1/2}} 25 \xrightarrow{T_{1/2}} 12.5$

3 half = 15.6 years

$T_{1/2} = \underline{15.6}$ years

3

12. a) $\begin{array}{ccccccc}
 & & 37 & & 0 & & 37 \\
 & & A & \longrightarrow & e & \longrightarrow & B \\
 & & 18 & & -1 & & 17
 \end{array}$

- b) i) Radioactive traces
 ii) - Causes cancer
 - Cell mutation
13. a) Nuclear fusion is where two light nuclei combine to give a heavy nucleus with release of energy while nuclear fission is where a large nucleus splits into smaller nuclei with the release of enormous amount of energy.
- b) Wrap with aluminium or lead foil and bury them deep underground

14. a) 4 He^{+2} or 4He
- $\begin{array}{cc}
 2 & 2
 \end{array}$
- b) i) $z_1 \rightarrow 235$
 $z_1 \rightarrow 54$

ii) Nuclear fission

15 a)

Nuclear reactions	Chemical reactions
Involves protons and neutrons	Involve valency electrons
Reaction rate not affected by element changes	Reaction rate is influenced by element changes
Involve huge amount of energy	Involve little amount of energy
There is change in mass	No change in mass

b) i) I: Alpha II: beta

ii) 210 206 4

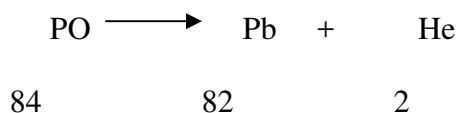

c) i)

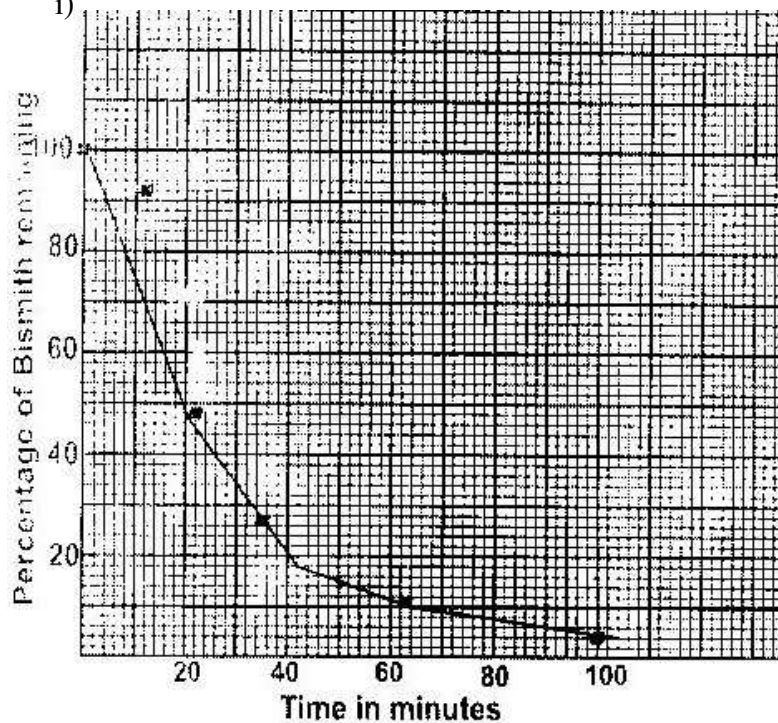

ii) 120 minutes

II % value at 70 minutes = $9\% \pm 2$

Mass = $\frac{0.16 \times 100}{9} = 1.778(g)$

$9\pm$

- d) - Treatment of cancer
- Sterilization of surgical equipment
- Treatment of leathion of goiter
- Regulate heart pace maker
- Detection of blood circulation disorders
- Measure of uptake of iodine.
16. a) Time take by radioactive isotopes to decay to half its mass.

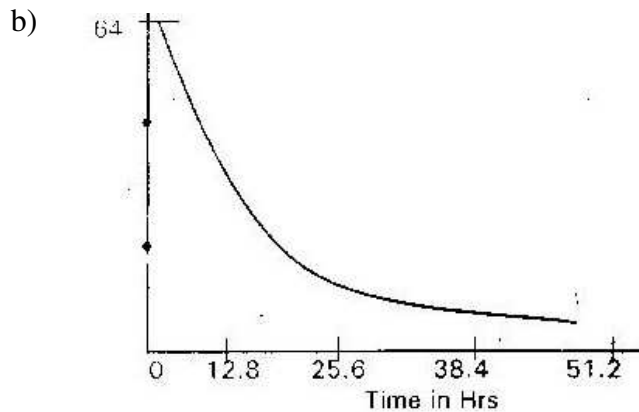

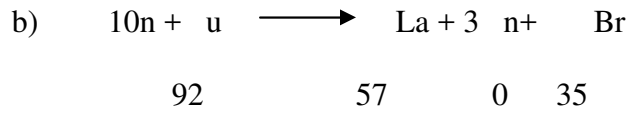
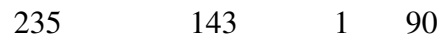
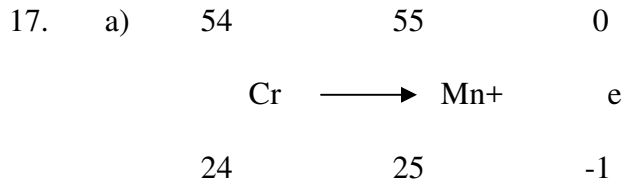

18. a)

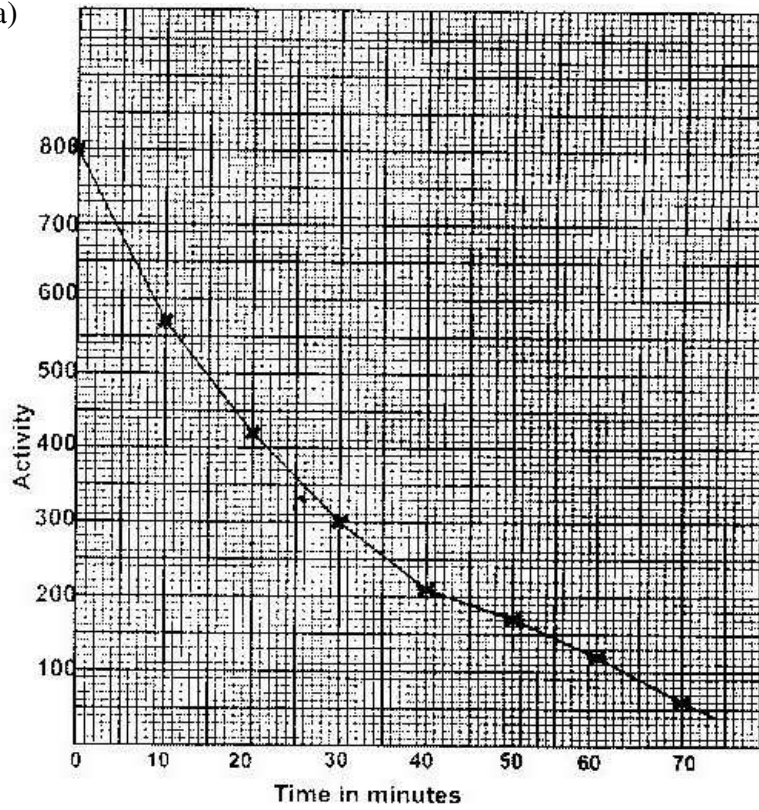

b) Half life = 22minutes

c) $\frac{110}{22} = 5$ half lifes

22

32 \longrightarrow 16 \longrightarrow 8 \longrightarrow 4 \longrightarrow 2 \longrightarrow 1

1g will remain

19. ${}_{90}^{234}$ ${}_{91}^{234}$ ${}_{92}^{234}$

X, Y, Z

90 91 92

20 i) The particles go through the inter atomic space in the metal foil because of their small size.

ii) Since the particles are positively charged, those which approach the nucleus are repelled.

iii) Those with low energy cannot overcome the repulsive forces hence are absorbed.

21. Days 2.5 \longrightarrow 5 \longrightarrow 7.5

Percentage ion \longrightarrow 50 \longrightarrow 25%

25% remains

22. a) X : Alpha

Y : Gamma

Z : Beta

b) They are very heavy/less

Penetrative /have large mass

