

# CHEMISTRY PAPER 2 KCSE

## PAST PAPERS<sub>(1995-2016)</sub>









*For marking schemes, call/Whatsapp-0745711892*



*'an investment of knowledge pays'*

*For marking schemes, prefer calling Mdm Mariam:0746711892*

Other available resources are;

-  well summarised primary and secondary notes
-  FI-F4 termly exams
-  primary exams
-  KCSE past papers
-  KCPE past papers
-  Mocks
-  lesson plans
-  schemes of work

*Note: Exam questions are always free of charge*

*Marking scheme are not free*

# CHEMISTRY PAPER 233/2

## K.C.S.E 1995 QUESTIONS

1. The table below gives information on four elements by letters K, L, M and N. Study it and answer the questions that follow. The letters do not represent the actual symbols of the elements.

Element	Electron arrangement	Atomic radius (nm)	Ionic radius(nm)
K	2, 8, 2	0.136	0.065
L	2, 8, 7	0.099	0.181
M	2, 8, 8, 1	0.203	0.133
N	2, 8, 8, 2	0.174	0.099

- a) Which two elements have two similar properties? Explain  
(2mks)
- b) What is most likely formula of oxide of L?  
(1mk)
- c) Which element is a non-metal? Explain (1 mk)
- d) Which one of elements is the strongest reducing agent? Explain  
(2mks)
- e) Explain why ionic radius of N is less than that of M  
(2mks)
- f) Explain why the ionic radius of L is bigger than its atomic radius  
(2mks)
- 2 a) IN an experiment hydrogen chloride gas was prepared and reacted with aluminium turnings to form a solid q and gas R as shown in the diagram below.

Aluminium  
turnings

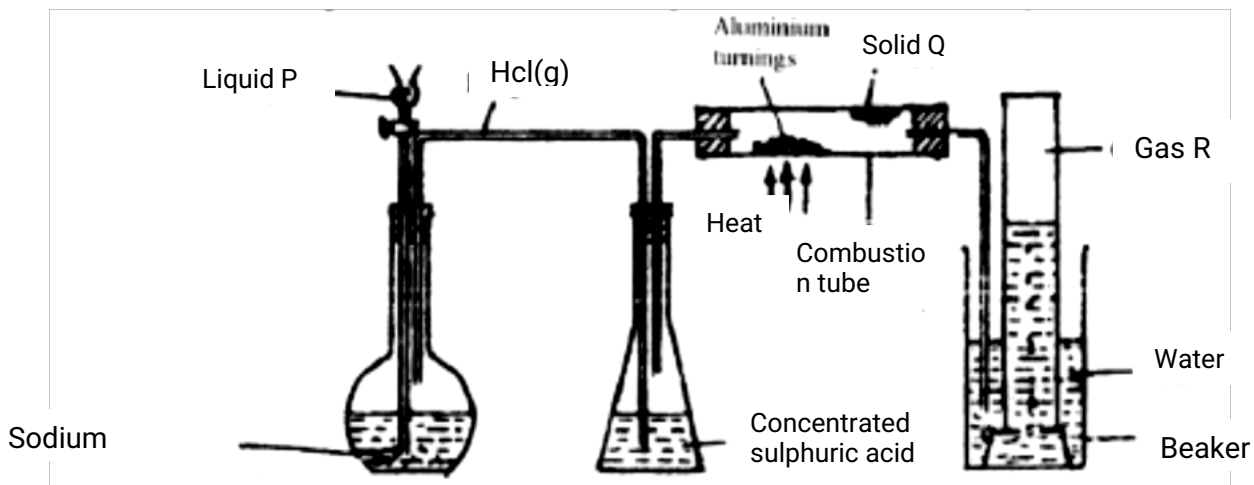

- (i) Name: Liquid P : Solid Q : Gas R (1mk)

- (ii) Name another substance that could serve the same purpose as the concentrated sulphuric acid. (1mk)

- (iii) Explain the following observation. When blue litmus paper was dipped into the water in the beaker at the end of the experiment it turned red. Explain why solid Q collects farther away from the heated aluminium (2mks)

- (b) (i) Write an equation for the reaction that takes place between ammonia gas and hydrogen gas (1mk)

- (ii) Calculate the mass of the product that would be formed when  $2000\text{cm}^3$  of hydrogen chloride gas reacts completely with excess ammonia gas (H=1, O; N= 14.0, C1 = 35.5, one mole of gas occupied 24 litres at room temperature and pressure.) (3mks)

3. In an experiment to determine the heat of combustion of methanol,  $\text{CH}_2\text{OH}$  a student used a set up like the one shown in the diagram below.

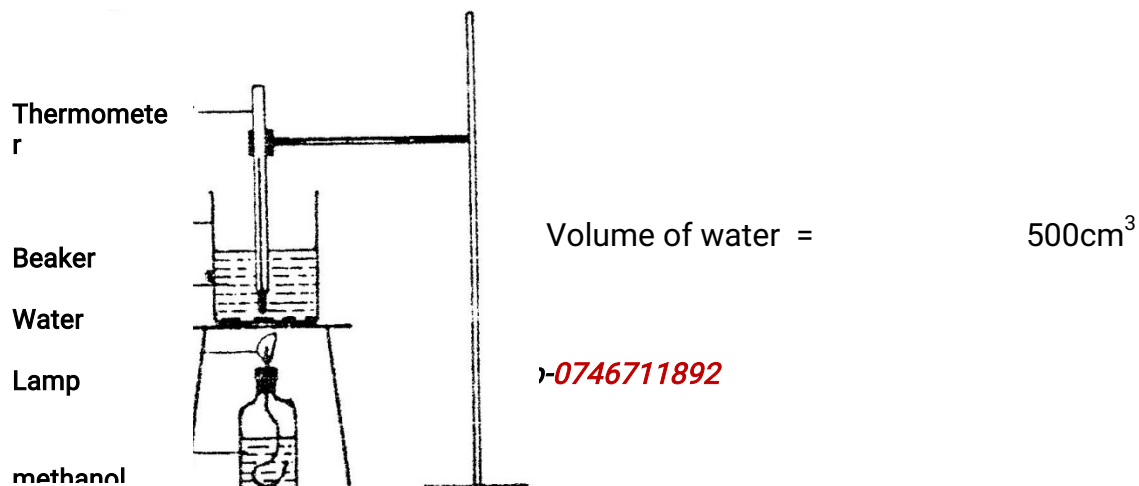

Final temperature of water = 27.0°C  
 Initial temperature of water = 20.0°C  
 Final mass of lamp + methanol = 22.11g  
 Initial mass of lamp + methanol = 22.98g  
 Density of water = 1.0g cm<sup>3</sup>

- a) Write an equation for the combustion of methanol  
 b) Calculate:  
 (i) The number of moles of methanol used in this experiment  
 (C = 12; O = 16; H = 1)  
 (ii) The heat of combustion per mole of methanol. (1mk)  
 (iii) The heat of combustion per mole of methanol (2mks)  
 (c) Explain why the value of the molar heat of combustion for methanol obtained in this experiment is different from the theoretical value.  
 (d) On the axis below draw an energy level diagram for the combustion of methanol.
4. a) The flow chart below outlines some of the process involved during extraction of copper from copper pyrites. Study it and answer the questions that follow.

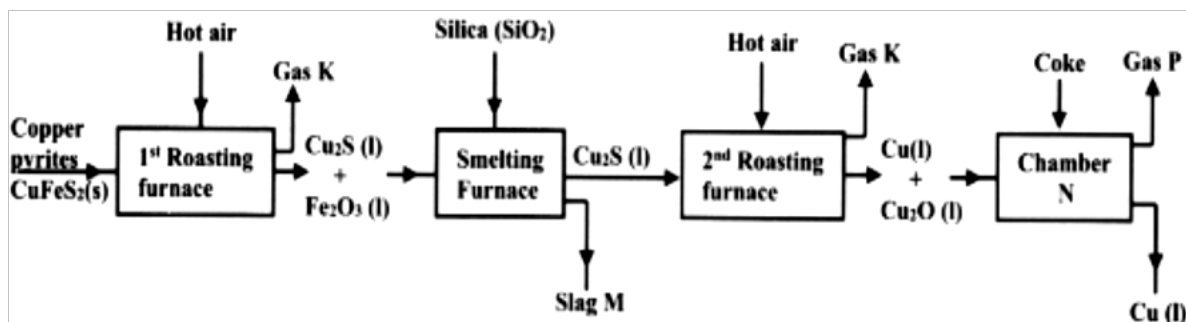

- (i) Name gas K (1mk)  
 (ii) Write an equation for the reaction that takes place in the 1<sup>st</sup> roasting furnace.  
 (1mk)  
 (iii) Write the formula of the cation present in slag M (1mk)  
 (iv) Identify gas p (1mk)  
 (v) What name is given to the reaction that takes place in chamber N? Give a reason for the answer. (1mk)

- (b) The copper obtained from chamber N is not pure. Draw a labeled diagram to show the set up you would use to refine the copper by electrolysis.  
(3mks)
- (c) Given that the mass of copper obtained from above extraction was 210kg, determine the percentage purity of the ore(copper pyrites) if 810kg of it was fed to the 1<sup>st</sup> roasting furnace. (Cu = 63.5, Fe = 56.0, s=32.0)  
(3mks)
- (d) Give two effects that this process could have on the environment  
(2mks)
5. The flow charts below show an analysis of a mixture R that contains two salts. Study the analysis and answer the questions that follow.

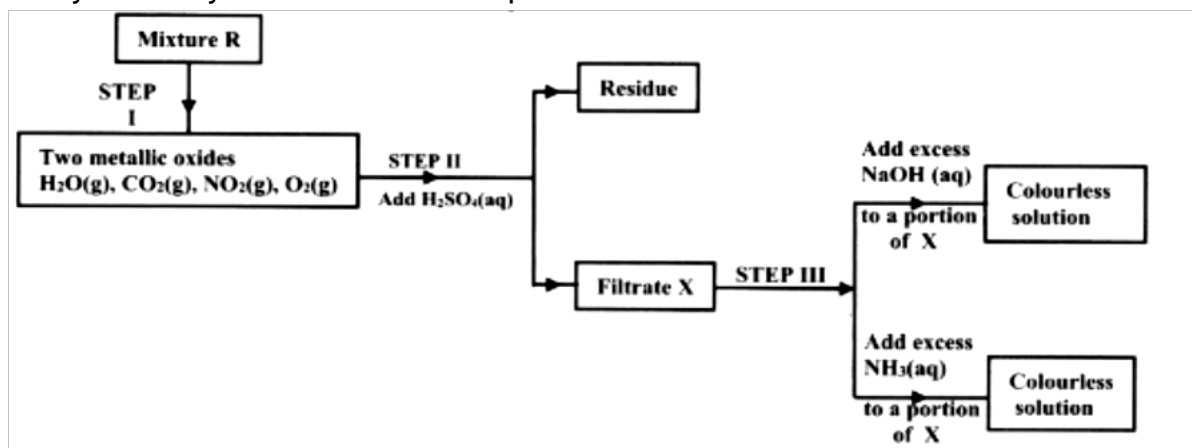

- (a) (i) What condition is necessary for the process in step I to take place?  
(1mk)
- (ii) Draw a labeled diagram for the set-up that could be used to separate the mixture formed in step II  
(2mks)
- (iii) Write ionic equation for the reaction between the cation in filtrate X and aqueous ammonia. (1mk)
- (iv) What observation would indicate the presence of  $\text{NO}_2(\text{g})$  in step I
- (v) State how water vapour, in step I could be identified. (1mk)
- (b)

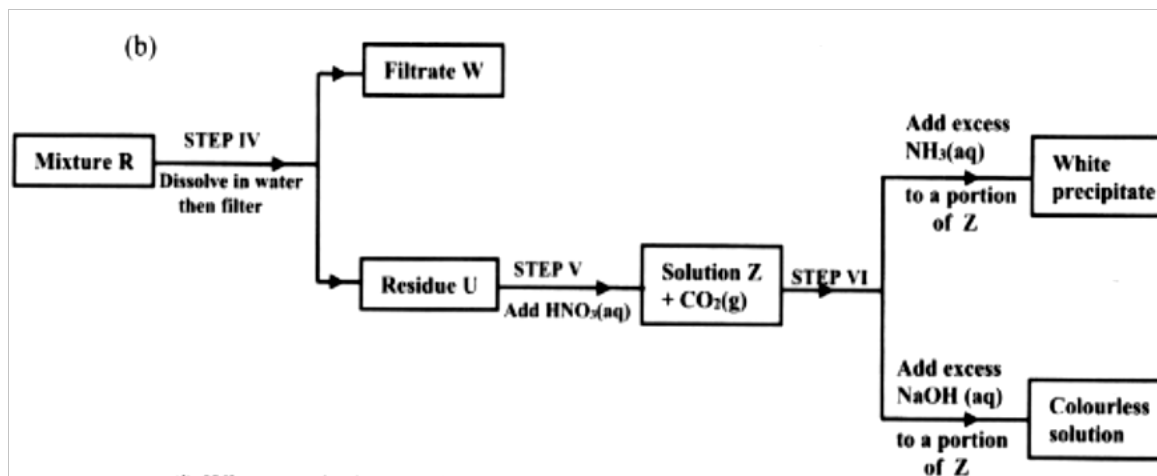

- (i) What conclusion can be drawn from step IV only? Explain? (2mks)
- (ii) Write the formula of an anion present in the residue U. Explain (2mks)
- (iii) Suggest the identity of the cation present in solution z. (1mk)
- (c) Name the two salts present in the mixture R. (2mks)

6. (a) The table below gives information about the major constituents of crude oil. Study it and answer the questions that follow.

Constituent	Boiling point ( $^{\circ}\text{C}$ )
Gases	Below 40
Petrol	40-175
Kerosene	175-250
Diesel oil	250-350
Lubricating oil	350-400
Bitumen.	Above 400

- (i) Which one of the constituents of crude oil has molecules with the highest number of carbon atoms? (2mks)
- (ii) Name the process you would use to separate a mixture of petrol and diesel and explain how the separation takes place. (2mks)
- (iii) Explain why the constituent of crude oil and write its formula (1mk)
- (iv) Name one gas that is likely to be a constituent of crude oil and write its formula. (1mk)
- (b) What condition could cause a poisonous gas to be formed when Kerosene is

burnt? Explain  
(2mks)

(c) Give one use of bitumen

(1mk)

7. (a) The diagram below shows a set-up that can be used to obtain nitrogen gas in an experiment.

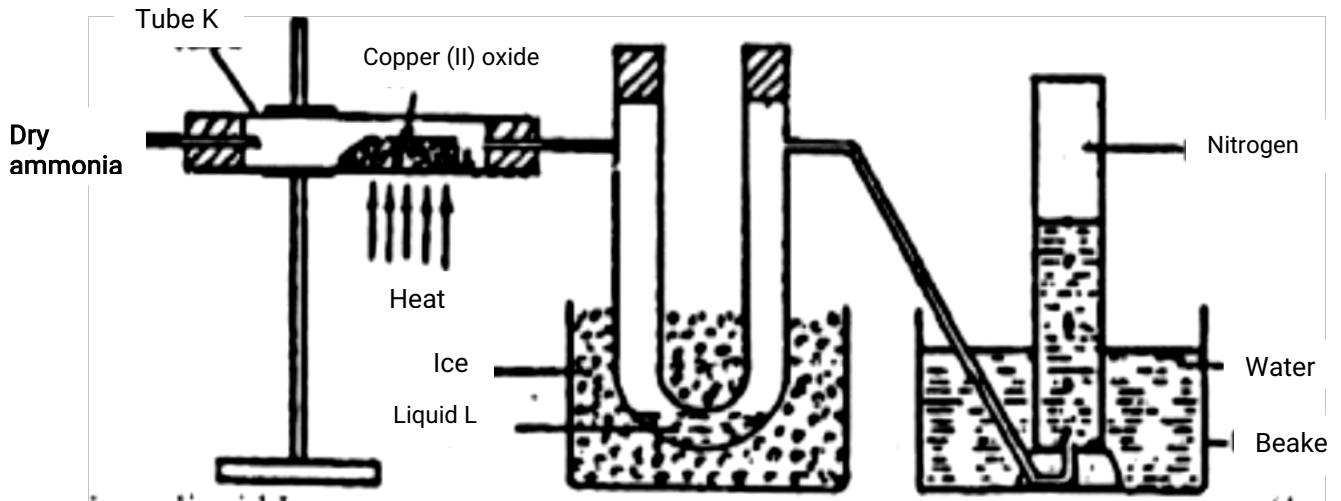

(i) Name liquid L  
(1mk)

(ii) What observation would be made in tube K after heating for some time?

(1mk)

(iii) Write an equation for the reaction that took place in tube K.

(1 mk)

(iv) If  $320 \text{ cm}^3$  of ammonia gas reacted completely with the copper?

Calculate:

I Volume of nitrogen gas produced.

(1mk)

II the mass of copper oxide that reacted

(3mks)

(Cu = 63.5, O=16.0, one mole of gas occupies 24 liters at room temperature and pressure)

(v) At the end of experiment the PH of the water in the beaker was found to be about 1)  
1) Explain (2mks)

(b) In another experiment a gas jar containing ammonia was inverted over a burning

splint. What observation would be made?  
(1mk)

- (c) Why is it advisable to obtain nitrogen from air instead ammonia?  
(1mk)



## CHEMISTRY PAPER 233/2

### K.C.S.E 1996 QUESTIONS

1. Sodium thiosulphate solution reacts with dilute hydrochloric acid according to the following equation.

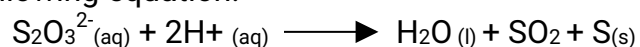

In an experiment to study how the rate of reaction varies with concentration, 10cm<sup>3</sup> of 0.4M sodium thiosulphate was mixed with 10cm<sup>3</sup> of 2M hydrochloric acid in a flask. The flask was placed in a white paper mked with across X. The time taken for the cross X become invisible when viewed from above was noted and recorded in the table below. The experiment was repeated three times as the temperature using the volumes in the table and the results recorded as shown in the table below.

Experiment	Volume of 0.4M thiosulphate (cm <sup>3</sup> )	Volume of water (cm <sup>3</sup> )	Volume of 2M HCl(cm <sup>3</sup> )	Time (Sec)
1	10	0	10	16
2	7.5	2.5	10	23
3	5.0	5.0	10	32
4	2.5	7.5	10	72

- a) i) On the grid below, plot a graph of the volume of thiosulphate (Vertical axis) against time taken for the cross (X) to become invisible
- ii) From the graph determine how long it would take for the cross to become invisible if the experiment was done.
- i) Using 6cm<sup>3</sup> of the 0.4M thiosulphate (1mk)
- ii) Using 6cm<sup>3</sup> of 0.2M thiosulphate solution (1mk)
- b) i) Using values for experiment I. Calculate
- (1mk) i) Moles of thiosulphate used
- ii) Moles of hydrochloric acid used (1mk)
- ii) Explain which of the two reactants in experiment I controlled the rate of the reaction? Explain (1mk)
- c) Give two precautions which should be taken in experiment I controlled the

rate of the reaction? Explain  
(2mk)

2. a) The diagram below shows incomplete set – up of the laboratory and preparation collection of chlorine gas. Study it and answer the questions that follow.

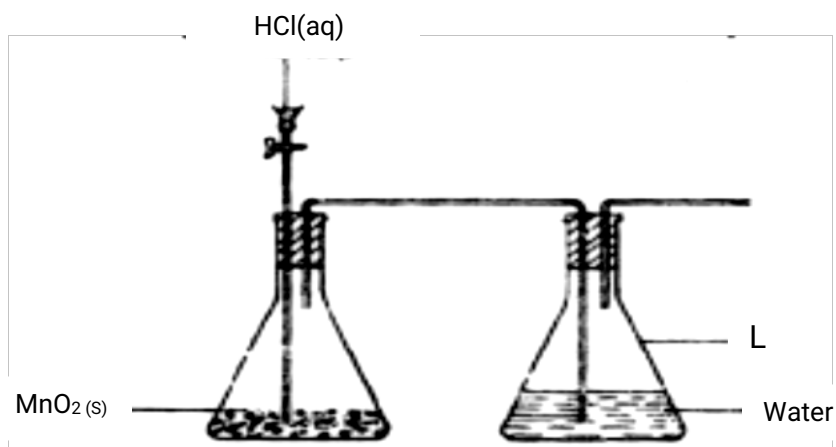

- i) Complete the set – up to show how dry chloride gas may be collected.
- ii) The equation for the redox reaction that takes place is  
$$\text{MnO}_2(\text{s}) + 4 \text{HCl}(\text{aq}) \rightarrow \text{MnCl}_2(\text{aq}) + 2\text{H}_2\text{O}(\text{l}) + \text{Cl}_2(\text{g})$$

Explain, using oxidation numbers, which species is reduced  
(2mks)

- iii) What is the purpose of water in flask L? (1mk)
- b) Study the diagram below and answer the questions that follow.

HCL gas

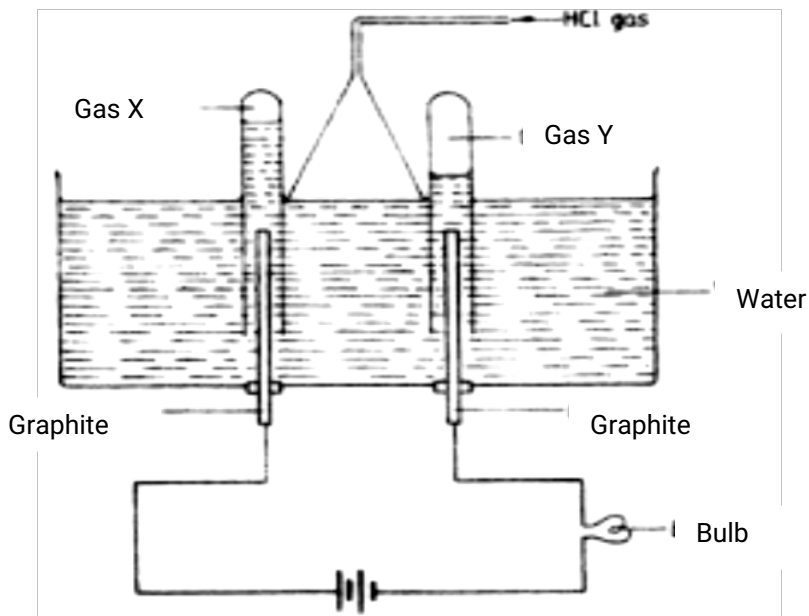

When some hydrogen chlorides gas is allowed into water and the mixture stirred, the bulb lights and gases X and Y are formed.

- i) Name: Gas X  
Gas Y
  - ii) Explain why the bulb does not light before the hydrogen chloride gas is let into water.  
(2mks)
  - iii) Explain using equations why the volume of gas X is less than that of gas  
(2mks)
3. The extraction of a luminium from it s ore takes place in two stages, purification stage and electrolysis stage. The diagram below shows the set – up for the electrolysis stage.

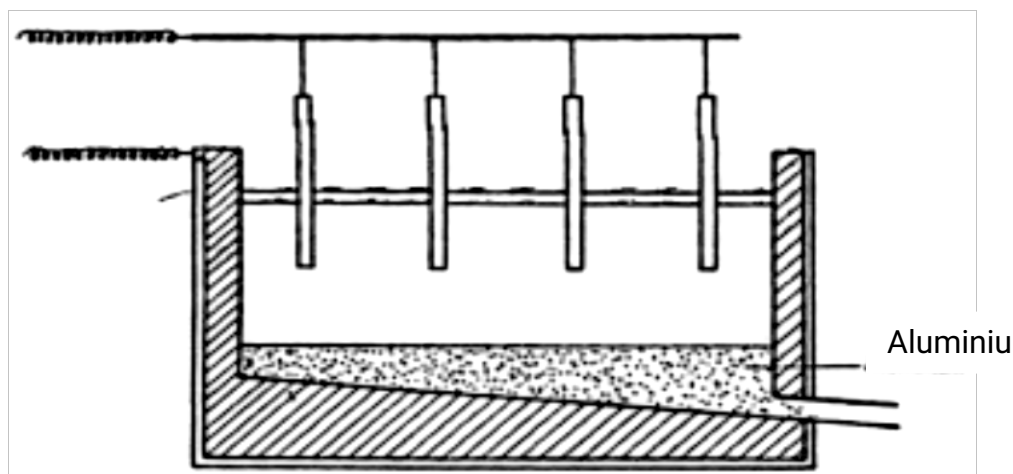

- a) i) Name the ore from which aluminium extracted. (1mk)  
 ii) Name one impurity, which is removed at the purification stage. (1mk)
- b) i) Label on the diagram each of the following  
 i) Anode  
 ii) Cathode  
 iii) Region containing the electrolyte.
- ii) The melting point aluminium oxide is  $2054^{\circ}\text{C}$ , but electrolysis is carried out between  $800 - 900^{\circ}\text{C}$ .  
 i) Why is the electrolysis not carried out at  $2054^{\circ}\text{C}$  (1mk)  
 ii) What is done lower the temperatures? (1mk)
- iii) The aluminium which is produced is tapped off as a liquid. What does this suggest about its melting point? (1mk)
- c) A typical electrolysis cell uses current of 40,000 amperes. Calculate the mass (in kilograms) of aluminium produced in one hour (3mks)

4. Study the table below and answer the questions that follow:

Element	Atomic number	Relative atomic mass	Melting point ( $^{\circ}\text{C}$ )

Aluminium	13	27.0	
Calcium	20	40.0	850
Carbon		12.0	3730
Hydrogen		1.0	-259
Magnesium	12	24.3	650
Neon	10		-249
Phosphorous	15	31.0	44.2 (white)
Sodium		23	590 (red)

- a) Complete the table by filling in this missing atomic numbers and atomic mass. (2mks)
- b) Write the electron arrangement for the following ions (2mks)
- $\text{Ca}^+$   
 $\text{P}^{3+}$
- c) What is the melting point of hydrogen in degrees Kelvin? (1mk)
- d) Which of the allotropes of phosphorous has a higher density? Explain (2mks)
- e) The mass numbers of three isotopes of magnesium are 24, 25 and 26. What is the mass number of the most abundant isotope of magnesium? Explain (2mks)
- f) Give the formula of the compound formed between aluminium and carbon. (1mks)
- g) Explain the difference in the melting points of magnesium and sodium. (2mks)

5. a) Study the table below and answer the questions that follow.

Compound	Melting point( $^{\circ}\text{C}$ )	Boiling point ( $^{\circ}\text{C}$ )
$\text{C}_2\text{H}_4\text{O}_2$	16.6	118
$\text{C}_3\text{H}_6$	-185	-47.7
$\text{C}_3\text{H}_8\text{O}$	-127	97.2
$\text{C}_5\text{H}_{12}$	-130	36.3
$\text{C}_6\text{H}_{14}$	-95.3	68.7

- i) Which of the compounds is a solid at  $10.0^{\circ}\text{C}$ ? Explain (1mk)
- ii) Choose two compounds which are members of the same homologous series and explain the difference in their melting points. (3mks)

- iii) The compound  $C_3H_8O$  is an alcohol. How does its solubility in water differ from the solubility of  $C_5H_{12}$  in water? Explain. (2mks)
- b) Complete combustion of one mole of a hydrocarbon produced four moles of carbon dioxide and four moles of water only.
- Write formula of the hydrocarbon (1mk)
  - Write the equation for the combustion reaction: (1mk)
- c) In a reaction, an alcohol J was converted to a hex-1-ene.
- Give the structural formula of the alcohol J
  - Name the reagent and conditions necessary for the reaction in c (i) above

- d) Compound K reacts with sodium hydroxide as shown below? (1mk)

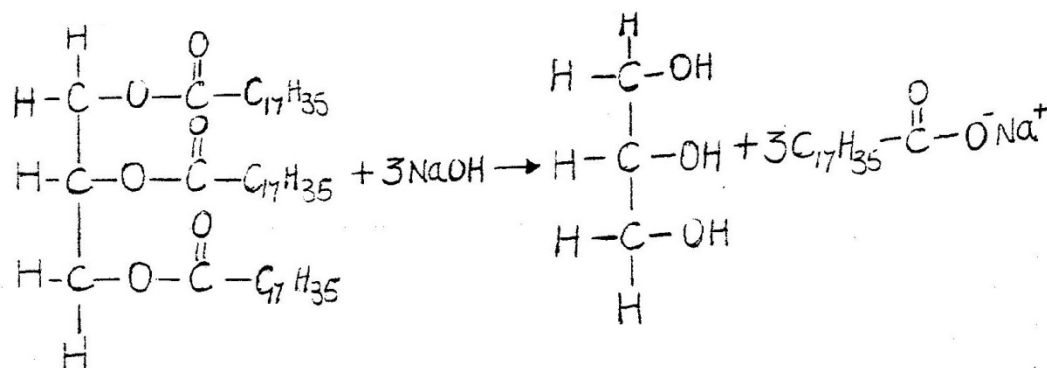

- What type of reaction is represented by the equation above? (1mk)
  - To what class of organic compounds does K belong? (1mk)
6. a) Give the name of each of the processes described below which takes place when salts are exposed to air for sometime.
- Anhydrous copper sulphate becomes wet (1mk)
  - Magnesium chloride forms an aqueous solution (1mk)
  - Fresh crystals of sodium carbonate,  $\text{Na}_2\text{CO}_3 \cdot 10\text{H}_2\text{O}$  (1mk)
- b) Write the formula of the complex ion formed in each of the reactions described below.
- Zinc metal dissolves in hot alkaline solution

(1mk)

(ii) Copper hydroxide dissolves in excess ammonia solution.

(1 mk)

(c) A hydrated salt has the following composition by mass. Iron 20.2% Oxygen 23.0%, sulphur 11.5%, water 45.3 %. Its relative formula mass is 278.

(i) Determine the formula of the hydrated salt..

(3mks)

(Fe=56, S=32; O = 16, H =1)

(ii) 6.95gm of the hydrates salt were dissolved in distilled water and the total volume made to 250 cm<sup>3</sup> of solution. Calculate the concentration of the salt solution in moles per litre.

7. (a) The graph below shows the solubility of sulphur dioxide gas at different temperatures. Use the following in it to answer the questions that follow.

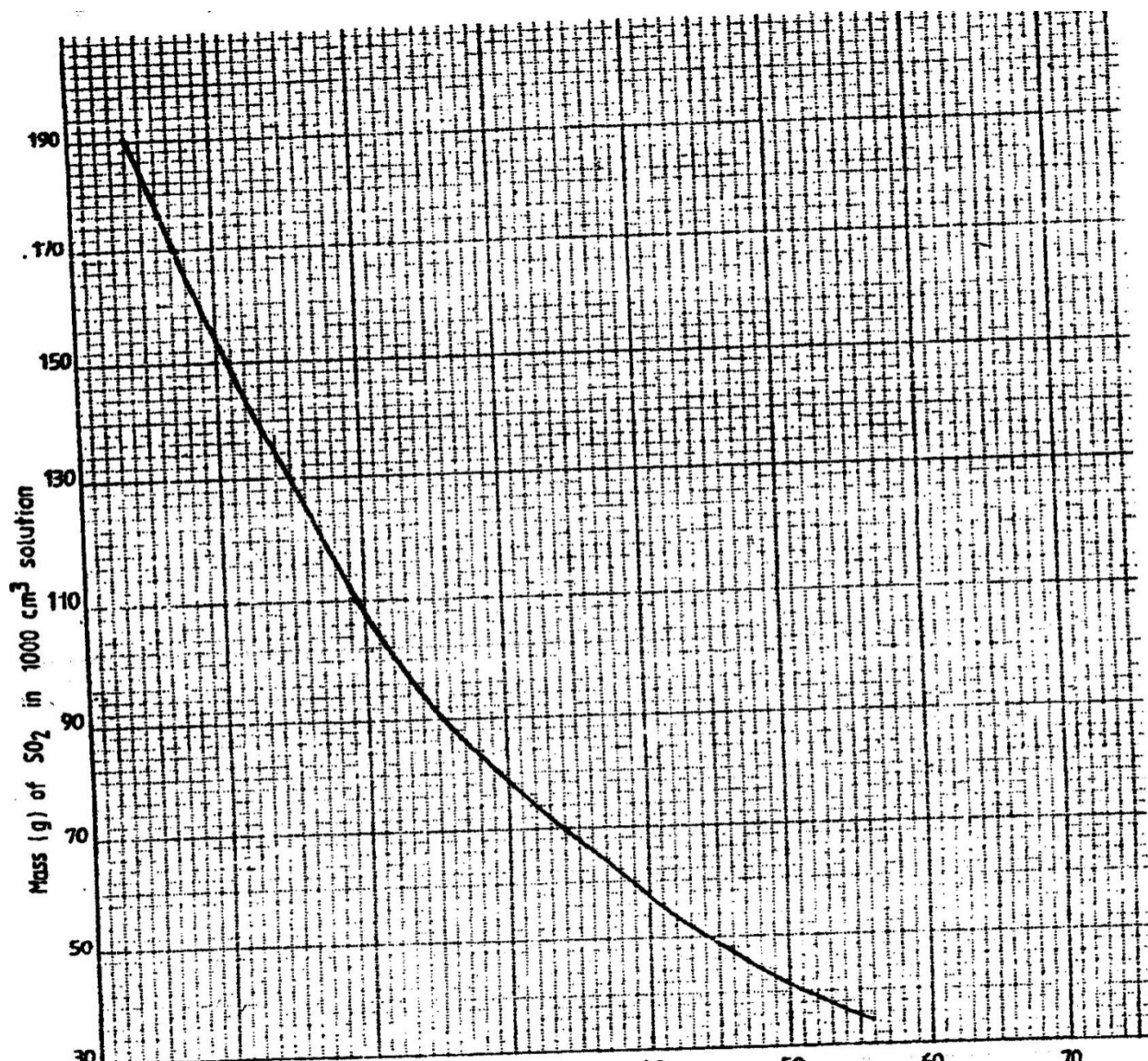

- (i) From the graph determine:
- I The lowest temperature at which  $1,000\text{cm}^3$  of solution would contain 116g of sulphur dioxide.
  - II The maximum mass of sulphur dioxide that would dissolve in 15 litres of solution at  $10^\circ\text{C}$

- (ii) Sodium hydroxide reacts with sulphur trioxide according to the following equation.

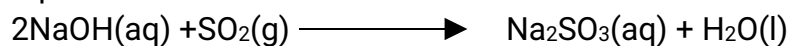

Using the information in the graph determine the volume of 2M sodium hydroxide required to completely neutralize one litre of saturated sulphur dioxide solution  $23^\circ\text{C}$ . (S=32.0; O = 16.0) (3mks)

- (b) Study the flow chart below and answer the questions that follow.

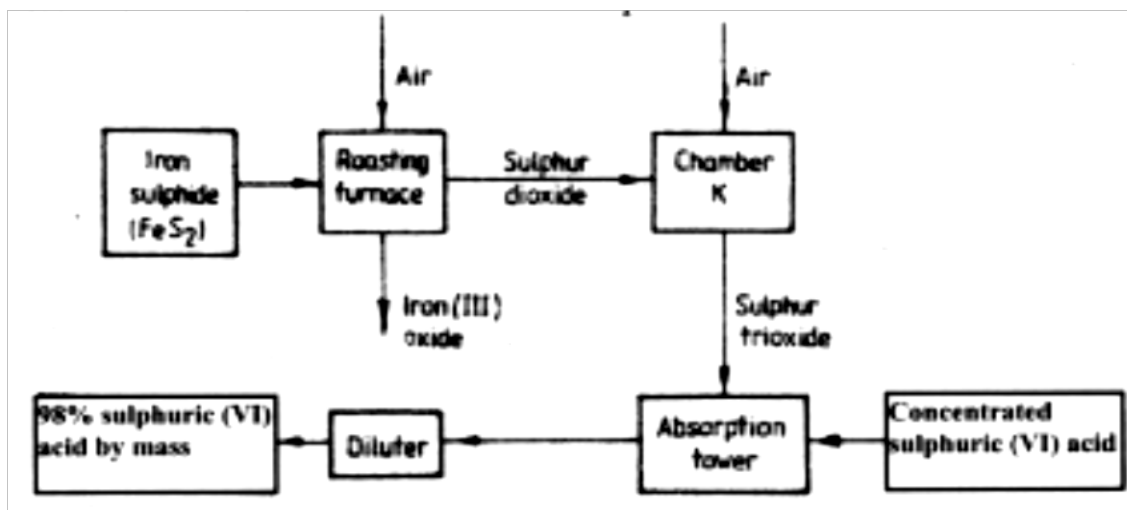

Write equation for the reaction taking place at:

- I The roasting furnace (1mk)



II The absorption tower

(1mk)

III The diluter

(1mk)

(ii) The reaction taking place in chamber K is



I Explain why it is necessary to use excess air in chamber K

II Name another substance used in chamber K

(c) Study the scheme given below and answer the questions that follow:

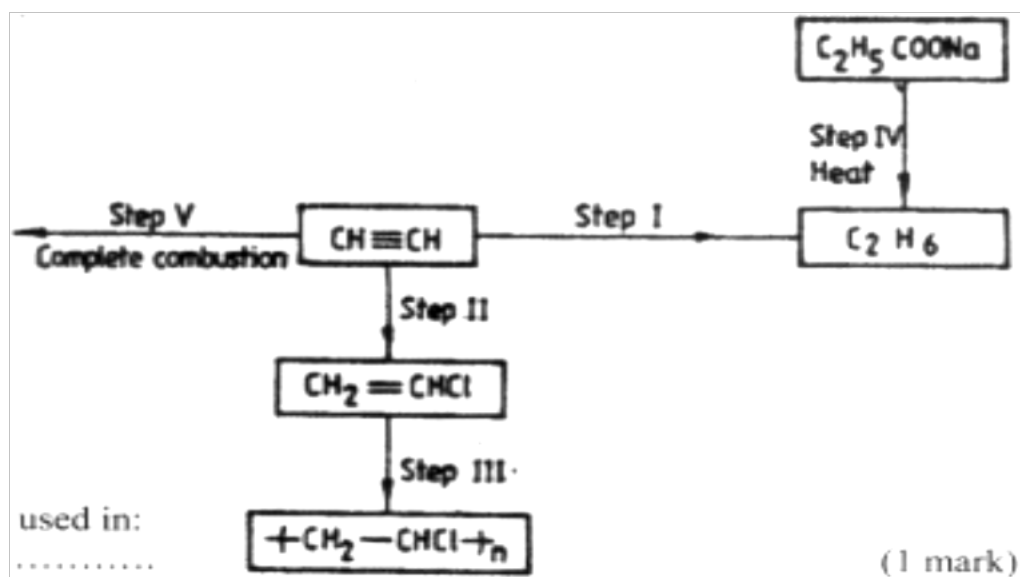

(i) Name the reagents used in:

Step I.....

(1mk)

Step II.....

(1mk)

Step IV.....

(1mk)

(ii) Write an equation for the complete combustion of  $\text{CH} = \text{CH}$

(1mk)

(iii) Explain one disadvantage of the continued use of items made from the compound formed in step III  
(2mks)

**CHEMISTRY PAPER 233/2**  
**K.C.S.E 1997 QUESTIONS**

1. Use standard electric potentials for elements A, B, C, D and F given below to answer the questions that follow.

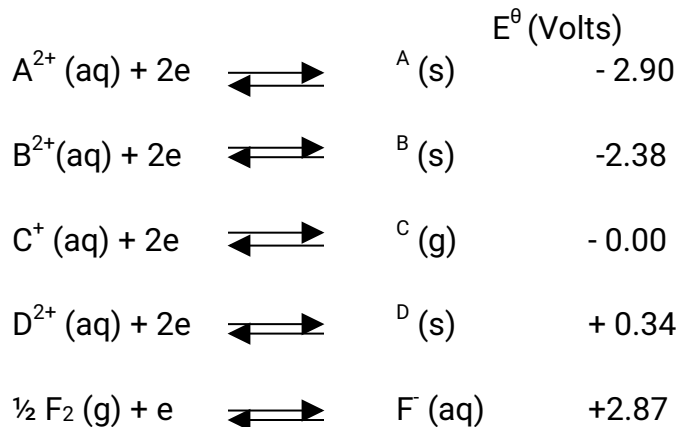

- (i) Which element is likely to be hydrogen? Give a reason for your answer
- (ii) What is the  $E^\ominus$  value of the strongest reducing agent?
- (iii) In the space provided draw a labeled diagram of the electrochemical cell that would be obtained when half-cells of elements B and D are combined
- (iv) Calculate the  $E^\ominus$  value of the electrochemical cell constructed in (iii) above
- (b) During the electrolysis of aqueous copper (II) sulphate using copper electrodes, a current of 0.2 amperes was passed through the cell for 5 hours
- (i) Write an ionic equation for the reaction that took place at the anode
- (ii) Determine the change in mass of the anode which occurred as a result of the electrolysis process  
(Cu = 63.5, 1 Faraday = 96,500 coulombs).
2. (a) Give the names of the following compounds
- (i)  $\text{CH}_3\text{CH}_2\text{CH}_2\text{CH}_2\text{OH}$
- (ii)  $\text{CH}_3\text{CH}_2\text{COOH}$
- (iii)  $\text{CH}_3\text{C-O-CH}_2\text{CH}_3$

(b) Study the information in the table below and answer the questions that follow

Number of carbon atoms per molecule	Relative molecular mass of hydrocarbon
2	28
3	42
4	56

- (i) Write the general formula of the hydrocarbon in the table
- (ii) Predict the relative atomic mass of the hydrocarbon with 5 carbon atoms
- (iii) Determine the molecular formula of the hydrocarbon in (ii) above and draw its structural formula (H = 1.0 C = 12.0)
- (c) Study the scheme given above and answer the questions that follow

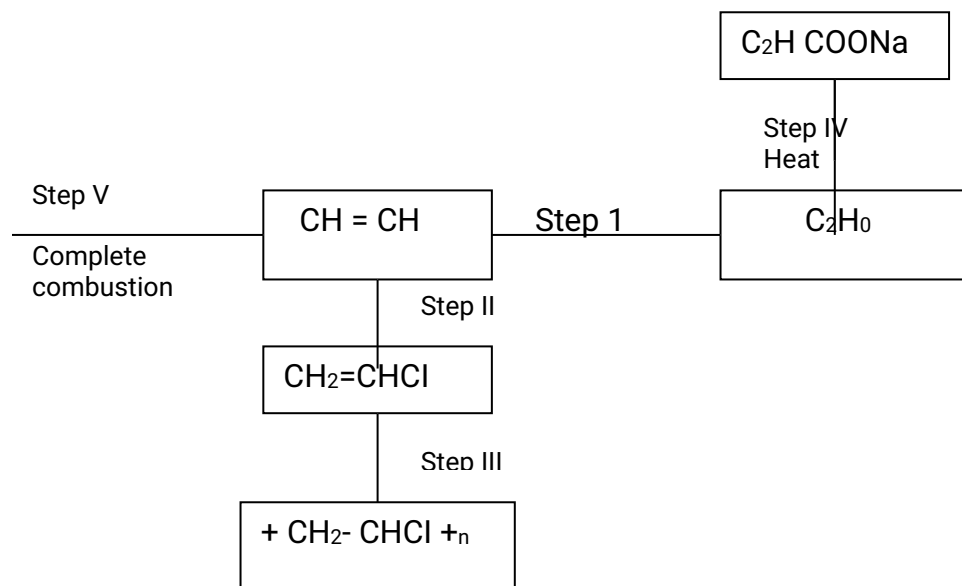

- (i) Name the reagents used in:
- Step I .....
- Step II .....
- Step III .....
- (ii) Write an equation for the complete combustion of  $\text{CH}=\text{CH}$
- (iii) Explain one disadvantage of the continued use of items made from the compound formed in step III

3. (a) Study the information below and answer the questions that follow:  
The letters do not represent the actual symbols of the elements

Element	Atomic Number	Melting Point Element	Formula of Chloride	Melting Point Chloride
G	11	98	GCl	801
H	12	650	HCl <sub>2</sub>	715
J	14	1410	JCl <sub>4</sub>	-70
K	16	113	K <sub>2</sub> Cl <sub>2</sub>	-80
L	20	851	LCl <sub>2</sub>	780

- (i) Which elements are metals? Give a reason
- (ii) Write the formula of the compound formed when element H reacts with elements K
- (iii) Explain why the melting point of J is higher than that of K
- (iv) What is the oxidation state of J in its chloride
- (v) How does the:  
I – Melting point of fluoride of G compare with that of its chloride?  
II- Reactivity of H and L with water compare? Give an explanation  
(2mks)

4. (a) The diagram below shows the extraction of sodium metal using the Downs cell. Study it and answer the questions that follow

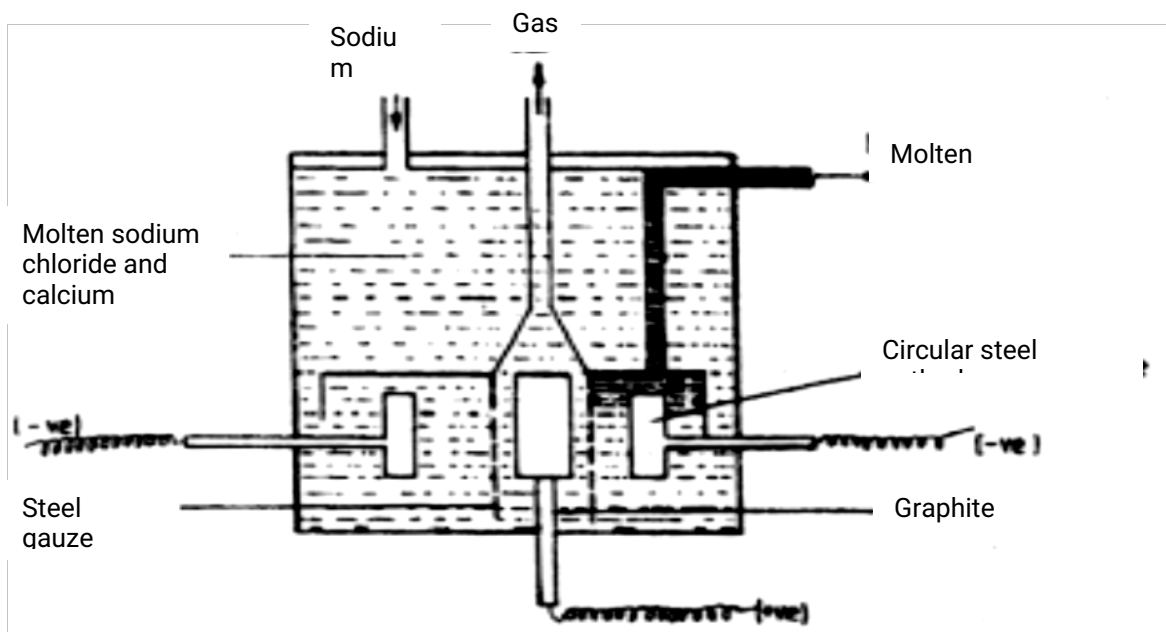

- (i) Explain why in this process the sodium chloride is mixed with calcium chloride.
  - (ii) Why is the anode made of graphite and not steel?
  - (iii) State two properties of sodium metal that make it possible for it to be collected as shown in the diagram
  - (iv) What is the function of the steel gauze cylinder?
  - (v) Write ionic equations for the reactions which take place at:  
I Cathode  
II Anode
  - (vi) Give one industrial use of sodium metal
- (b) Explain why the sodium metal is kept stored under kerosene

5. The reaction between and methanoic acid at 30<sup>0</sup> C proceeds according to the information given below



Concentration of Br <sub>2</sub> (aq) Moldm <sup>-3</sup>	Time minutes
10.0 x 10 <sup>-3</sup>	0
8.1 x 10 <sup>-3</sup>	1
6.6 x 10 <sup>-3</sup>	2
4.4 x 10 <sup>-3</sup>	4
3.0 x 10 <sup>-3</sup>	6
2.0 x 10 <sup>-3</sup>	8
1.3 x 10 <sup>-3</sup>	10

- (a) On the grid below, plot a graph of concentration of Bromine (Vertical axis against time)
- (b) From the graph determine:
- The concentration of bromine at the end of 3 minutes
  - The rate of reaction at time 't' where t = 1 ½ minutes
- (c) Explain how the concentration of bromine affects the rate of reaction
- (d) On the same axis sketch the curve that would be obtained if the reaction was carried out at 20<sup>0</sup> C and label the curve as curve II. Give a reason for your answer.
6. (a) The diagram below represents a set up that was used to obtain dry nitrogen from air. Study it and answer the questions that follow

Iron powder

Nitrogen  
---

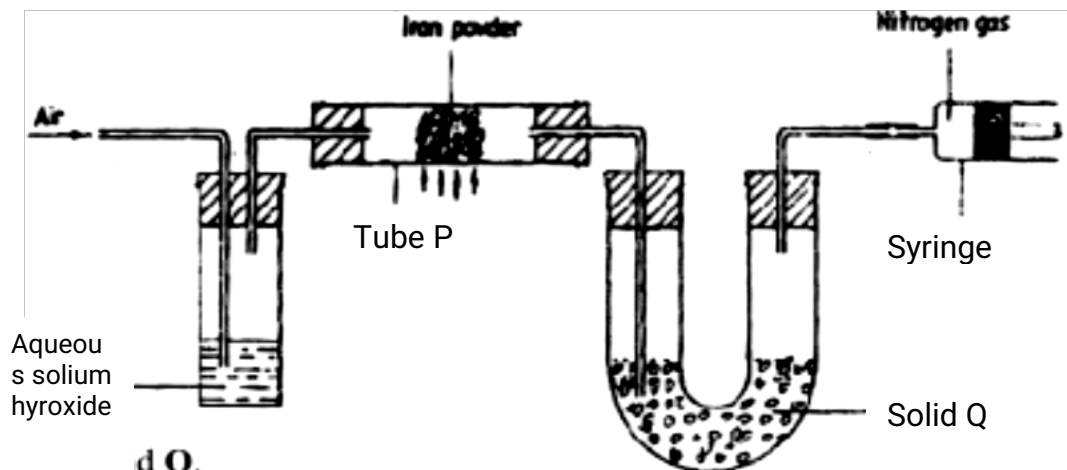

- (i) Name solid Q
- (ii) What is the purpose of sodium hydroxide?
- (iii) Write an equation for the reaction which took place in tube P  
Give the name of one impurity present in the nitrogen gas obtained
- (iv) Give a reason why liquid nitrogen is used for storage of semen for artificial insemination
- (b) The set up below was used to prepare nitric acid

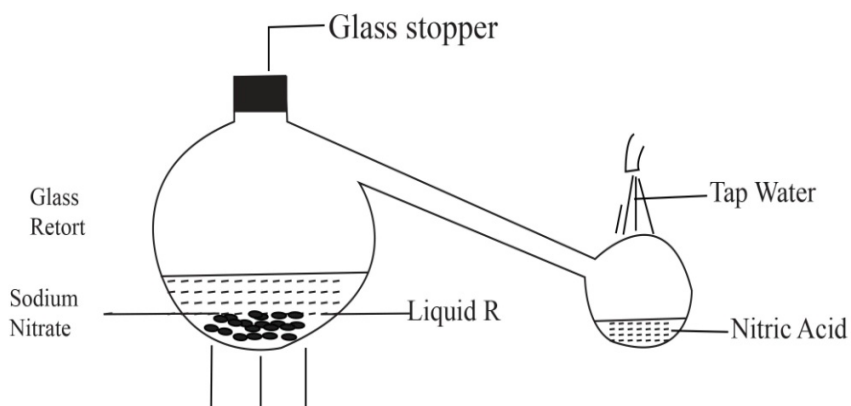

- (i) Give the name of liquid R
- (ii) Write an equation for the reaction which took place in the glass retort
- (iii) Explain the following
- I. Nitric acid is stored in dark bottles
  - II. The reaction between copper metal with 50% nitric acid (one volume of

acid added to an equal volume of water) in an open test tube gives brown fumes.

- (c) A factory uses nitric acid and ammonia gas as the only reactants for the preparation of fertilizer. If the daily production of the fertilizer is 4800 kg calculate the mass of ammonia gas used daily.



7. (a) In an experiment, dry hydrogen chloride gas was passed through heated zinc turnings as shown in the diagram below. The gas produced was then passed through heated lead (II) oxide.

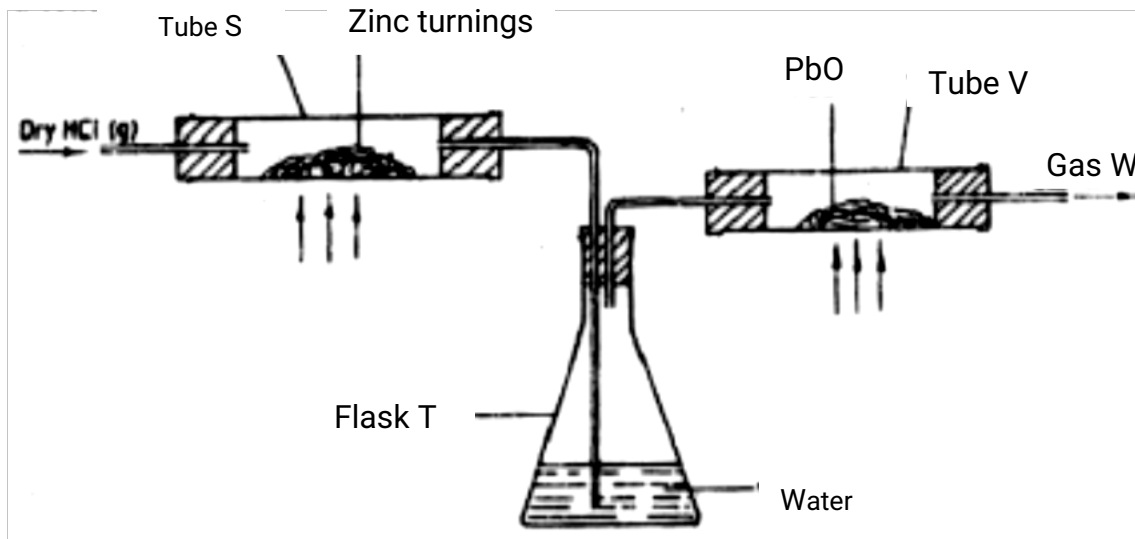

- (i) What is the function of water in the flask?  
Write equations for the reactions that took place in the tubes  
S  
V
- (ii) How would the total mass of tube V and its contents compare before after the experiment? Explain
- (b) Chloride can be prepared by using the following three agents; solid sodium chloride, concentrated sulphuric acid and potassium permanganate
- (i) What is the role of each of the following in the reaction?  
I Concentrated sulphuric acid  
II potassium permanganate
- (ii) Name the bleaching agent formed when chlorine gas is passed through cold dilute sodium hydroxide solution
- (iii) Name one other use of the compound formed in (ii) above other than Bleaching
- (c) 1.9 gm of magnesium chloride was dissolved in distilled water. Silver nitrate solution was added until in excess. Calculate the mass of silver nitrate that was used for the complete reaction. Relative molecular mass of magnesium chloride = 95, N = 14.0, O = 16.0, Ag = 108.0

## CHEMISTRY PAPER 233/2

### K.C.S.E 1998 QUESTIONS

1. (a). An ore is suspected to contain mainly iron. Describe a method that can be used to confirm the presence of iron in the ore
- (b) Excess carbon monoxide gas was passed over a heated sample of an oxide of iron as shown in the diagram below. Study the diagram and the data below it to answer the questions that follow.

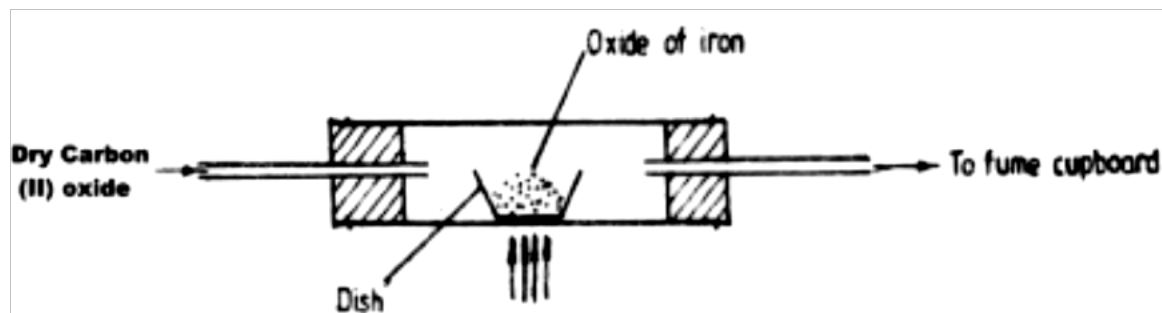

Mass of empty dish	=	10.98g
Mass of empty dish + oxide of iron	=	13.30g
Mass of empty dish + residue	=	12.66g

- (i) Determine the formula of the oxide of iron. (relative formula mass of oxide iron = 232, Fe = 56.0, O = 16.0)
- (ii) Write an equation for the reaction which took place in the dish
- (c) Corrosion is a destructive process in which iron which is converted into hydrated iron (III) oxide  
State:
- (i) two conditions necessary for rusting to occur
  - (ii) One method used to protect iron from rusting
- (d) Explain why it is not advisable to wash vehicles using seawater
2. (a) The following equations represent two different types of reactions
- (i)  $n\text{C}_4\text{H}_8(\text{g}) \longrightarrow (\text{C}_4\text{H}_8)_n(\text{s})$
  - (ii)  $\text{C}_2\text{H}_6(\text{g}) + \text{Cl}_2(\text{g}) \xrightarrow{\text{U.V.}} \text{C}_2\text{H}_5\text{Cl}(\text{l}) + \text{HCl}(\text{g})$

State the type of reaction represented by:

- (i)
- (ii)

(b) The fermentation of glucose produces ethanol as shown in the equation below



- (i) State how the concentration of ethanol produced could be increased
  - (ii) State and explain the observation that would be made when a piece of sodium metal is added to a sample of ethanol contained in a beaker
  - (iii) Give two commercial uses of ethanol other in the manufacture of alcoholic drinks
- (c) The molecular formula of a hydrocarbon is  $\text{C}_6\text{H}_{14}$ . The hydrocarbon can be converted into two other hydrocarbons as shown by the equation below

- (i) Name and draw the possible structural formula of X  
Name  
Structural formula
- (ii) State and explain the observation that would be made if a few drops of bromide water were added to a sample of X.
- (iii) Write an equation for the complete combustion of  $\text{C}_3\text{H}_8$

3. The flow chart below shows the industrial preparation of ammonia and the process used

in the manufacture of some ammonium compounds. Study and answer the questions that follow

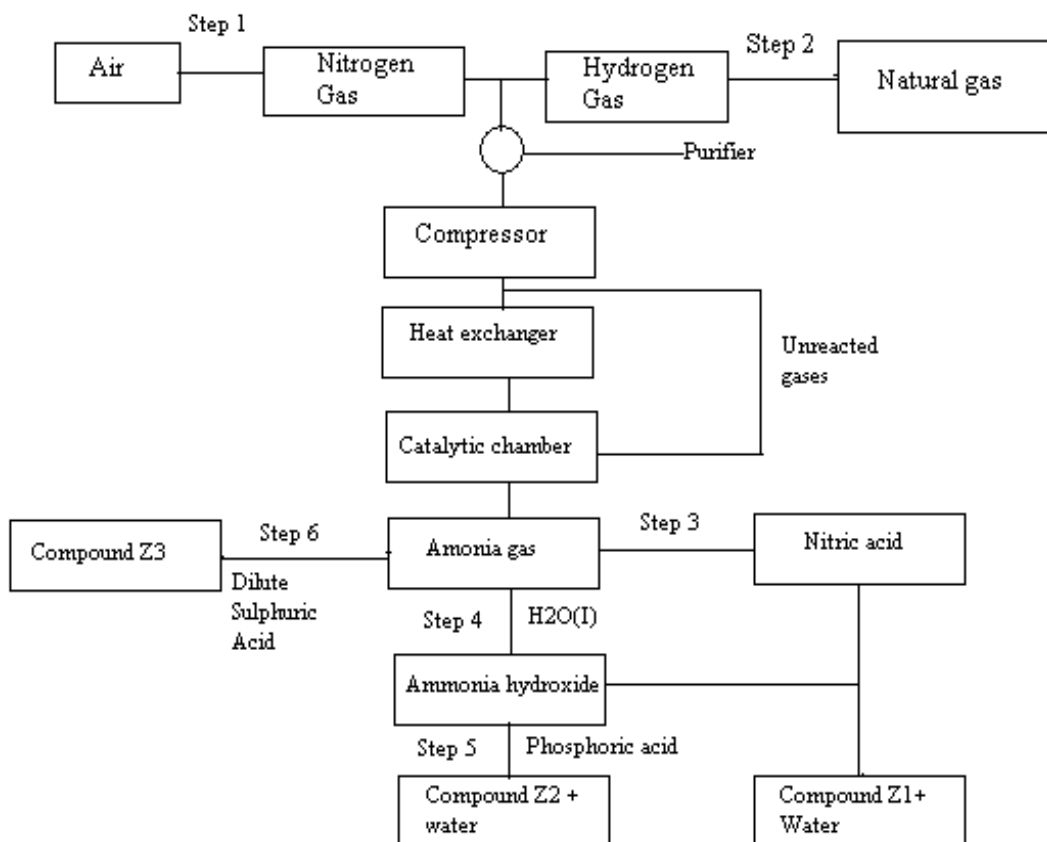

- Give the name of the
  - Process in step 1
  - Reaction that takes place in step 5
- State one other source of hydrogen gas apart from natural gas
- Explain why it is necessary to compress nitrogen and hydrogen in this process
- Write an equation for the reaction which takes place in step 6
- Name the catalyst and the reagents used in step 3
 

Catalyst

Reagent
- Name compound Z1
- Give one commercial use of compound Z2

4. The set – up below was used to prepare anhydrous chlorides of a number of elements in a laboratory where no fine cupboard was available. The chlorides were to be collected in flask

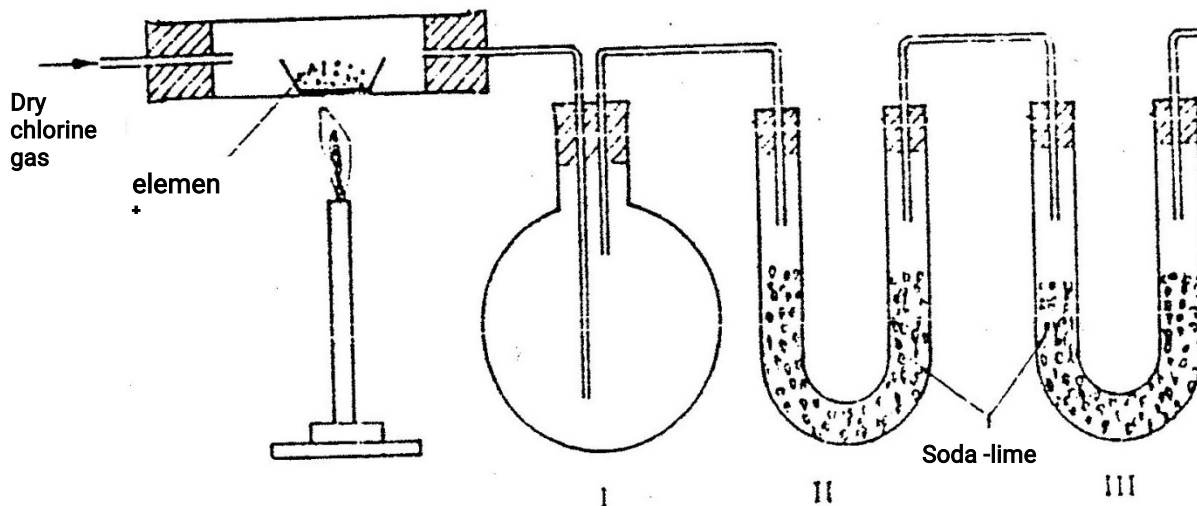

The following table shows the melting and boiling points of the chlorides that were prepared.

- Explain why it is necessary to pass dry chlorine through the apparatus before heating each element
  - Give two reasons why tubes II and III were filled with Soda lime (solid mixture of sodium hydroxide and calcium hydroxide)
  - Explain why it would not be possible to collect any sodium chloride in flask I
  - Name one other substance that can be used in tubes II and III
  - Write an equation for the reaction that forms phosphorous (III) chloride
  - Describe how you would separate a mixture of sodium chloride and aluminium chloride
5. (a) The table below gives the solubilities of hydrated copper (II) sulphate in mol dm<sup>3</sup> at different temperatures
- On the grid provided, plot a graph of solubility of copper (II) sulphate (vertical axis) against temperature.
  - From the graph, determine the mass of copper (II) sulphate deposited when solution is cooled from 70<sup>o</sup> C to 40<sup>o</sup> C.
- (Molar mass of hydrated copper (II) sulphate = 250g)

- (b) In an experiment to determine the solubility of sodium chloride,  $5.0\text{cm}^3$  of a saturated solution of sodium chloride weighing  $5.35\text{g}$  were placed volumetric and diluted to a total volume of  $250\text{cm}^3$

$25.0\text{cm}^3$  of the dilute solution chloride completely reacted with  $24\text{cm}^3$  of  $0.1\text{M}$  silver nitrate solution.

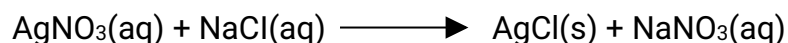

Calculate:

- (i) Moles of silver nitrate in  $24\text{cm}^3$  of solution
  - (ii) Moles of sodium chloride in  $25.0\text{cm}^3$  of sodium
  - (iii) Moles of sodium chloride in  $250\text{cm}^3$  of solution
  - (iv) Mass of sodium chloride in  $5.0\text{cm}^3$  of saturated sodium chloride Solution (Na = 23.0, Cl = 35.5)
  - (v) Mass of water in  $5.0\text{cm}^3$  of saturated solution of sodium chloride
  - (vi) The solubility of sodium chloride in g/100 water
5. In order to determine the molar of neutralization of sodium hydroxide,  $100\text{cm}^3$  of  $1\text{M}$  sodium hydroxide and  $100\text{cm}^3$  of  $1\text{M}$  hydrochloric acid both at the same initial temperature were mixed and stirred continuously with a thermometer. The thermometer of the resulting solution was recorded after every 30 seconds until the highest temperature of the solution was attained. Thereafter the temperature of the solution was recorded for a further two minutes

- (a) (i) Why was it necessary to stir the mixture of the two minutes  
(ii) Write an ionic equation for the reaction which took place

(iii) The sketch below was obtained when the temperature of the mixture were plotted against time. Study and answer the questions that follow.

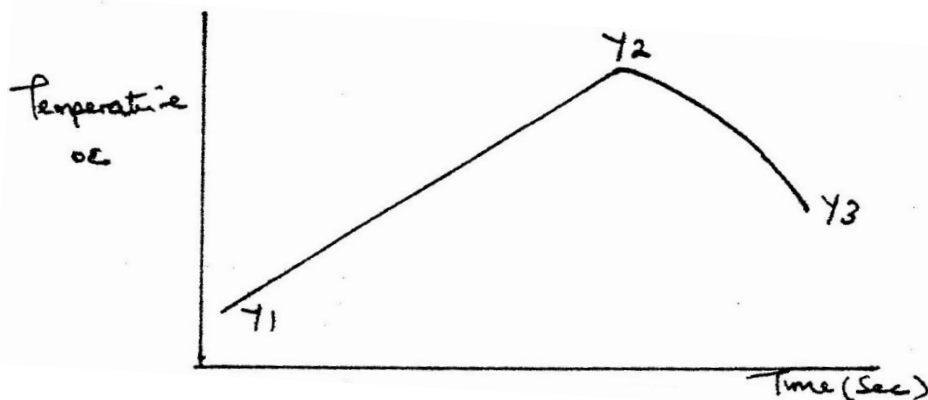

- I. What is the significance of point Y2?
  - II. Explain why there is a temperature change between points Y1 and Y2  
Y3 and Y4
- (iv) In the initial temperature for both solutions was  $24.5^{\circ}\text{C}$  and the highest temperature attained by the mixture was  $30.9^{\circ}\text{C}$   
Calculate the:
- I. heat change for the reaction  
(specific heat capacity of the solution =  $4.2\text{Jg}^{-1}\text{K}^{-1}$  and the density of the solution =  $1.0\text{g/cm}^3$ )
  - II. Molar heat of neutralization of sodium hydroxide
- (v) Explain how the value of the molar heat of neutralization obtained in this experiment would compare with the one that would be obtained if the experiment was repeated using  $100\text{cm}^3$  of 1 Methanoic acid instead of hydrochloric acid.
- (b) On the grid provided below, draw an energy level diagram for the reaction between hydrochloric acid and sodium hydroxide
6. Study the information given in the table below and answer the questions that follow. The letters do not represent the actual symbols of the elements

Element	Atomic number	Boiling point
S	3	1603
T	13	2743
U	16	718
V	18	87
W	19	1047

- (a) Select the elements which belong to the same
- (i) Group
  - (ii) Period
- (b) Which element
- (i) Is in gaseous state at room temperature? Explain  
(Take room temperature to be 298K)

- (ii) Does not form an oxide?
- (c) Write the
- (i) Formula of the nitrate of element
  - (ii) Equation for the reaction between elements S and U
- (d) What type of bond would exist in the compound formed when U and T react?  
Give a reason for your answer
- (e) The aqueous sulphate of element W was electrolyzed using inert electrodes Name the products formed at the:
- (i) Cathode
  - (ii) Anode



**CHEMISTRY PAPER 233/2**  
**K.C.S.E 1999 QUESTIONS**

1. The table below gives the volume of the gas provided when different volumes of 2M hydrochloric were reacted with 0.6g of magnesium powder at room temperature

Volume of 2M hydrochloric acid (cm <sup>3</sup> )	Volume of gas (cm <sup>3</sup> )
0	0
10	240
20	480
30	600
40	600
50	600

- (a) Write an equation for the reaction between magnesium and hydrochloric acid
- (b) On the grid provided plot a graph of the volume of gas produced (vertical axis), against the volume of acid added (Note the reaction comes to completion, the volume of the gas produced directly proportional to completion, the acid added).  
From the graph determine
- c) i) The volume for the gas produced if 12.5cm<sup>3</sup> of 2M hydrochloric acid had been used.  
ii) The volume of 2M hydrochloric acid which when reacted completely with 0.6 of magnesium powder.
- e) Given that one mole of the gas occupied 24000cm<sup>3</sup> at room temperature.

Calculate the relative atomic mass of magnesium.

2. The set – up below was used during the electrolysis of aqueous magnesium sulphate using inert electrodes.

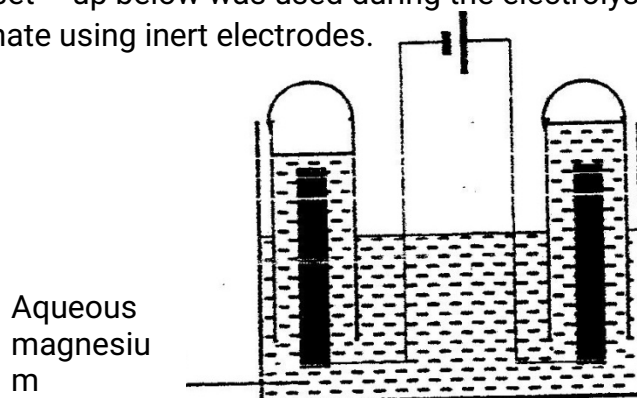

- i) name a suitable pair of electrodes for this experiment
- ii) Identify the ions and cations in the solution
- iii) On the diagram label the cathode
- iv) Write ionic equations for the reactions that took place at the anode.
- v) Explain the change that occurred to the concentration of magnesium sulphate solution during the experience.
- vi) During the electrolysis a current of 2 amperes was passed through the solution for 4 hours. Calculate the volume of the gas produced at the anode.(1 faraday 96500 coulombs and volume of a gas at room temperature is 24000cm<sup>3</sup>)
- vii) One of the uses of electrolysis is electroplating
  - I) What is meant by electroplating?
  - II) Give two reasons why electroplating is necessary.

3. Study the information in the table below and answer the questions that follow. The letters do not represent the symbols of the elements.

Element(C)	Atomic number	Melting point
L	11	97.8
M	13	660
N	14	1440
Q	17	401
R	19	63.7

- a) Write the electrons arrangement for the atom formed by elements and M and Q
- b) Select an element which is
  - i) The most reactive non – metal
  - ii) A poor conductor of electricity
- c) In which period of the periodic table does elements R below.
- d) Element R loses its outermost electron more readily than L. Explain
- e) Using dots(.) and crosses (x) to represent outermost electrons show

bonding in the compound formed elements N and Q.

- f) Explain why the melting point elements M is higher than that of element .
- g) Describe how a solid mixture of sulphate of R and lead sulphate can be separated into solid samples.

4. a) The flow chart below shows a sequence of reactions starting with iron. Study and answer the questions that follow.

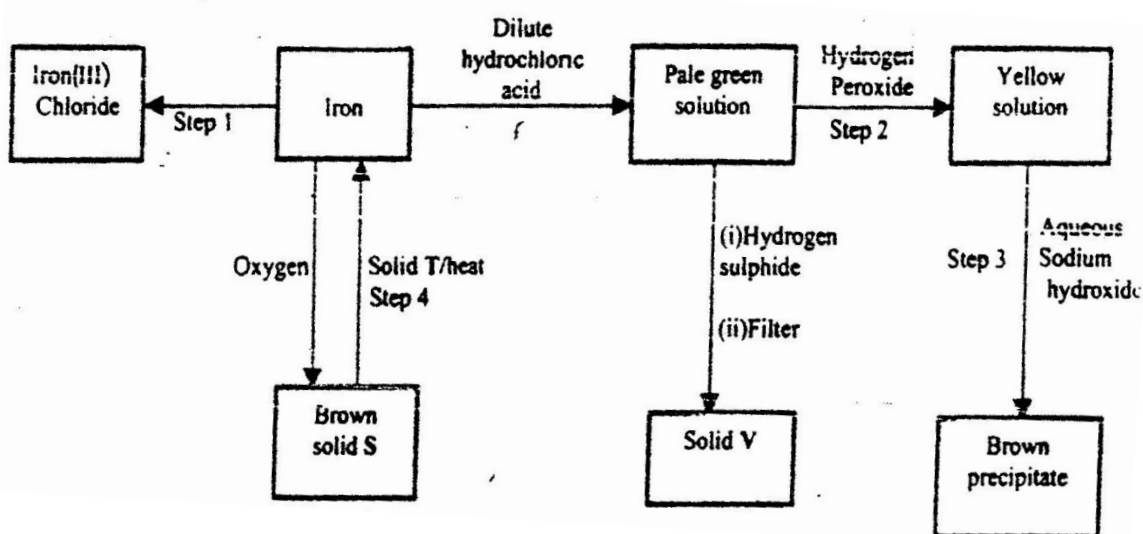

- i) Name the reagent and state the condition for the reaction in step.  
Reagent  
Condition
  - ii) Give the names of the following
    - i) Solid S
    - ii) Solid V
    - iii) Solid T
  - iii) Give reasons for the colour change in step 2
  - ii) Write an ionic equation for the reaction which takes place in step 3.
  - v) Name one other substance that could be used instead of sodium hydroxide in step III.
- b) In an experiment 3.36g of iron fillings were added to excess aqueous copper(II) sulphate. Calculate the mass of copper that was deposited.  
Cu = 63.5, Fe = 56.0

5. a) When an organic compound Y is reacted with aqueous sodium carbonate, it produces carbon dioxide reacts with propanol to form a sweet smelling compound Z whose formula is.

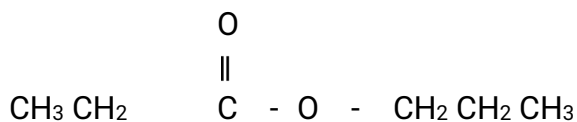

- Name and draw the structural formula of compound Y.
  - What is the name of the group of compounds to which Z belongs?
- b) In an experiment excess ethanol was warmed with potassium dichromate for about twenty minutes. State and explain the observation that was made at the end of the experiment.
- c) The scheme below was used to prepare a cleaning agent. Study and answer the questions that follow.

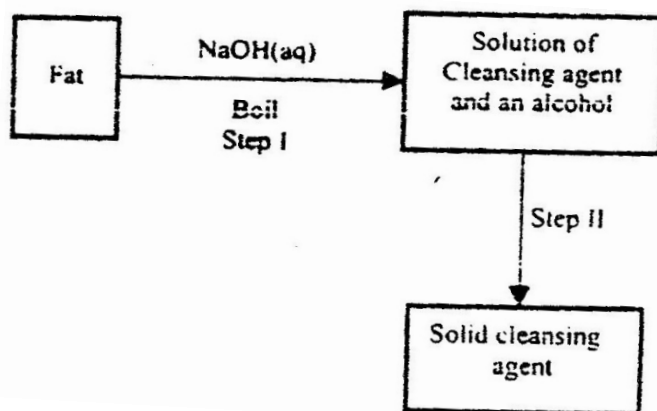

- What name is given to the type of cleaning agent prepared by the method shown in the scheme?
- Name one chemical substance added in step II
- What is the purpose of adding the elements substance names in C(ii) above.
- Explain how an aqueous solution of the cleansing removes oil from utensils during washing.

6. a) The diagram below shows a set –up used by as a student in an attempt to prepare and collect oxygen gas.

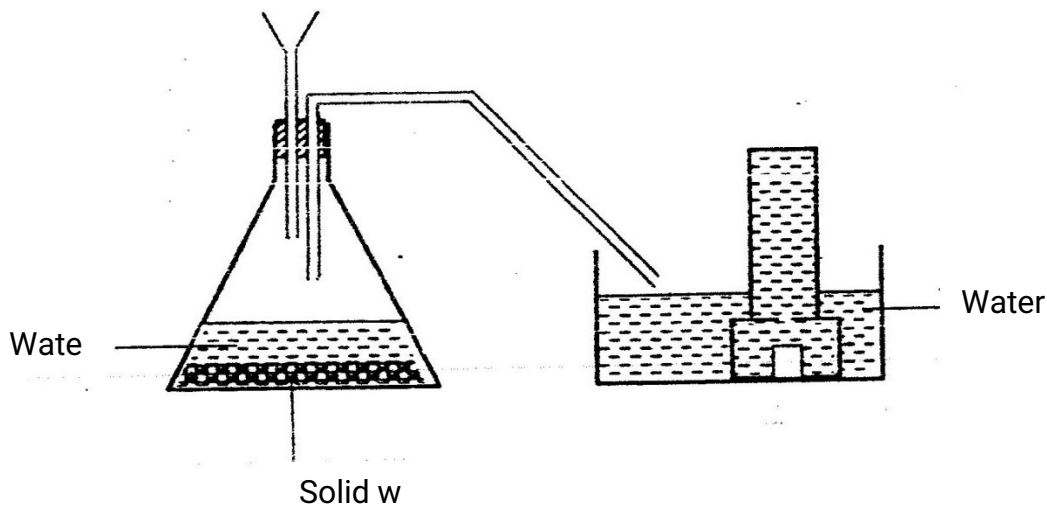

- i) Complete the diagram correcting the mistakes on it
  - ii) Identify solid W.
- a) A piece of phosphorus was burnt in excess and the product obtained was shaken with a small amount of hot water to make a solution.
- i) Write an equation for the burning of phosphorus in excess air.
- b) Explain why cooking pots made of aluminium do not corrode when exposed to air.
- c) The reaction between sulphur dioxide and oxygen to form trioxide in the contact process is exothermic.
- $$2\text{SO}_2(\text{g}) + \text{O}_2(\text{g}) \rightleftharpoons 2\text{SO}_3(\text{g})$$

Factory manufacturing sulphuric acid by contact process produces 350kg of sulphur trioxide per day (conditions) for the reaction catalyst. 2 atmospheres pressure and temperatures between. (400 – 500 °C)

- i) What is meant by an exothermic reaction?
- ii) How would the yield per day of sulphur trioxide be affected if lower temperatures than 400°C are used? Explain.



## CHEMISTRY PAPER 233/2

### K.C.S.E 2000 QUESTIONS

1. (a) The grid given below represents part of the periodic table. Study it and answer the questions that follow. (the letters do not represent the actual symbol of the elements)

													A
							B						
	C						D			E			
	F												

- (i) What name is given to the group of elements to which C and F belong?
- (ii) Which letter represents the element that is the least reactive?
- (iii) What type of bond is formed when B and E react? Explain
- (iv) Write the formula of the compound formed when element D and oxygen gas react
- (v) On the grid, indicate with a tick the position of element G which is in the third group, indicate with a tick the position of element G which is in the third period of the periodic table and forms  $G^{3-}$  ions
- (b) Study the information in the table below and answer the questions that follow (the letters do not represent the actual symbol of the substances)

Substance	Melting Point ( $^{\circ}C$ )	Boiling Point ( $^{\circ}C$ )	Solubility in water	Density at room temperature $g/cm^3$
H	-117	78.5	Very soluble	0.8
J	-78	-33	Very soluble	$0.77 \times 10^{-3}$
K	-23	77	Insoluble	1.6
L	-219	-183	Slightly soluble	$1.33 \times 10^{-3}$

- (i) Which substance would dissolve in water and could be separated from the

solution by fractional distillation? Give a reason

- (ii) Which substances is a liquid at room temperature and when mixed with water two layers would be formed?
- (iii) Which letter represents a substance that is gas at room temperature and which can be collected:

I. Over water? Explain

II. By downward displacement of air? (Density of air is  $1.29 \times 10^{-3} \text{g/cm}^3$  at room temperature.

- 2 (a) The diagram below represents a mercury cell that can be used in the industrial manufacture of sodium hydroxide. Study it and answer the question that follow

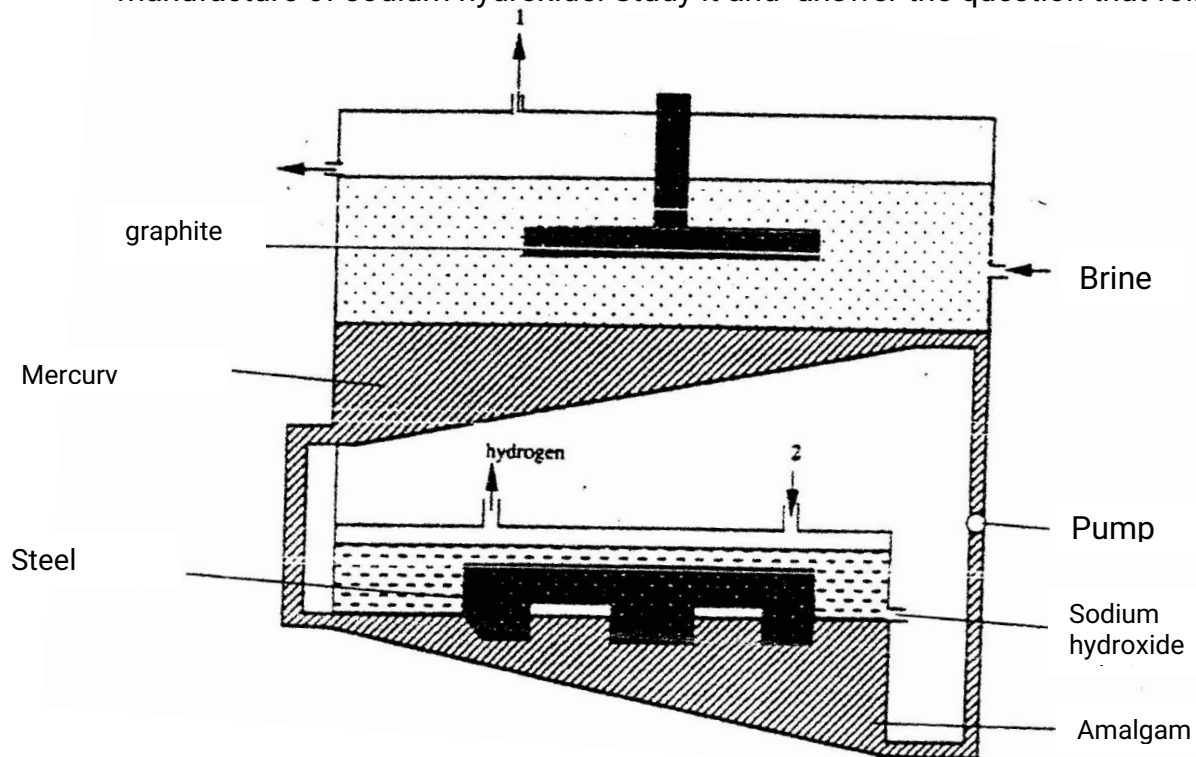

(i) Name

I. the raw material introduced at 2

II. Another substance that can be used in the cell instead of graphite

(ii) Identify the by – product that comes out at 1

(iii) Give

I. One use of sodium hydroxide

II. Two reasons why mercury is recycled



- (b) A current of 100 amperes was passed through the cell of five (5) hours
- Write the equation for: The reaction that occurred at the mercury cathode
  - Calculate the mass of sodium hydroxide that was produced  
(Na = 23.0, O = 16.0, H = 1.0, 1 Faraday = 96500 Coulombs)

- 3 The flow chart below illustrate the industrial extraction of lead metal. Study it and answer the questions that follow.

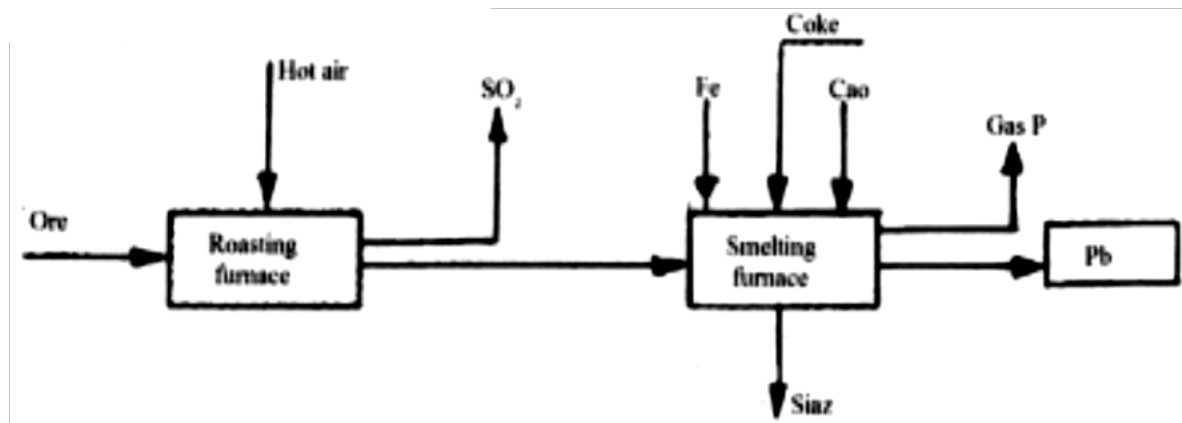

- Name the ore that is commonly used in this process
    - Explain what takes place in the roasting furnace
    - Identify gas P
    - Write the equation for the main reaction that takes place in the smelting Furnace
    - What is the purpose of adding iron in the smelting furnace?
    - Give two environmental hazards likely to be associated with extraction of Lead
  - Explain why hard water flowing in lead pipes may be safer for drinking than soft water flowing in the same pipes
  - State one use of lead other than the making of lead pipes
4. (a) (i) In the space provided sketch a labeled diagram to show how hydrogen chloride gas can be prepared and collected in the laboratory using sodium Chloride and concentrated sulphuric acid ( the gas need not be dry)
- Write an equation for the reaction that takes place
  - Name one drying agent for hydrogen chloride

- (vi) State and explain the observation that would be made when hydrogen chloride gas is bubbled through a solution of lead (II) nitrate
- (v) Concentrated hydrochloric acid is used for removing oxide from metal surfaces (picking). Explain why concentration nitric acid cannot be used for the purpose.
- (b) A sample of hydrogen chloride gas was dissolved in water to make 250cm<sup>3</sup> of solution required 46cm<sup>3</sup> of 11.0M Sodium hydroxide for complete neutralization.
- (i) Calculate the number of moles of hydrochloric acid in 25cm<sup>3</sup> of solution
- (ii) Determine the mass of hydrogen chloride that was dissolve to make 250cm<sup>3</sup> of solution (Cl = 35.5, H=1.0)
5. (a) Give the names of the following compounds
- (i) CH<sub>3</sub>CH = CHCH<sub>2</sub>CH<sub>3</sub>

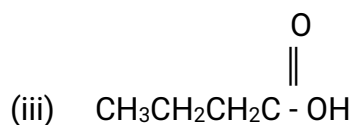

- (b) Ethane and Ethene react with bromine according to the equation given below
- (i)  $\text{C}_2\text{H}_6(\text{g}) + \text{Br}_2(\text{g}) \longrightarrow \text{C}_2\text{H}_5\text{Br}_2(\text{g}) + \text{HBr}(\text{g})$

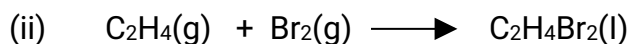

- c) Name the type of bromination reaction that takes place in: (i) and (ii)

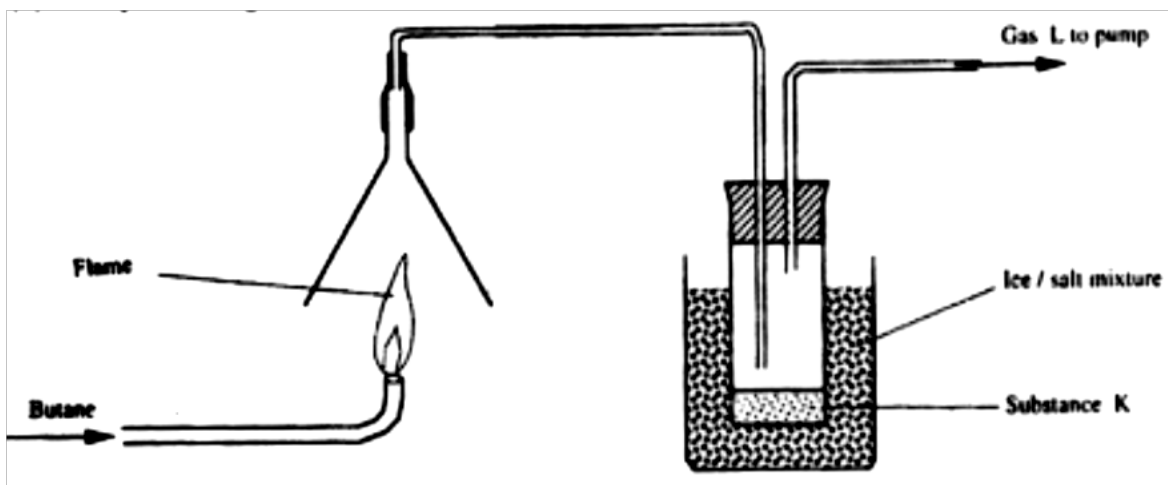

- (i) Write the equation for the combustion of butane
- (ii) The pH of substances K was found to be less than 7. Explain this observations
- (d) The polymerization of tetra flouroathene ( $C_2F_4$ ) is similar to that of ethane ( $C_2H_4$ )
  - (i) What is meant by the term polymerization?
  - (ii) Draw the structural formula of a portion of the polymer obtained from the monomer  $C_2H_4$
- (e) State any two advantages that synthetic polymers have over natural polymers

6. (a) The following diagrams show the structures of two allotropes of carbon. Study them and answer the questions that follow

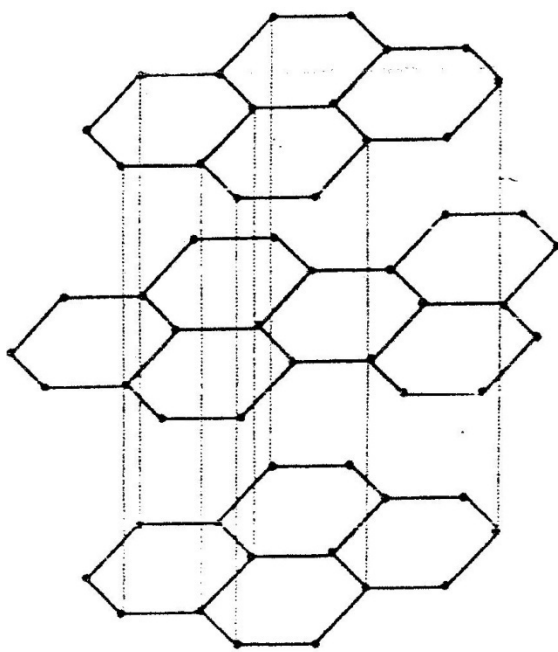

Allotrope M

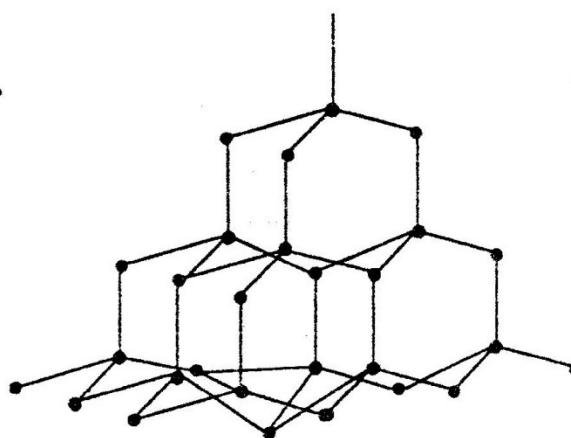

Allotrope N

- (i) Name allotrope  
M  
N
- (ii) Give one use of N

(iii) Which allotrope conducts electricity? Explain

- (b) In an experiment, carbon dioxide gas as passed over heated charcoal and the gas produced collected as shown in the diagram below

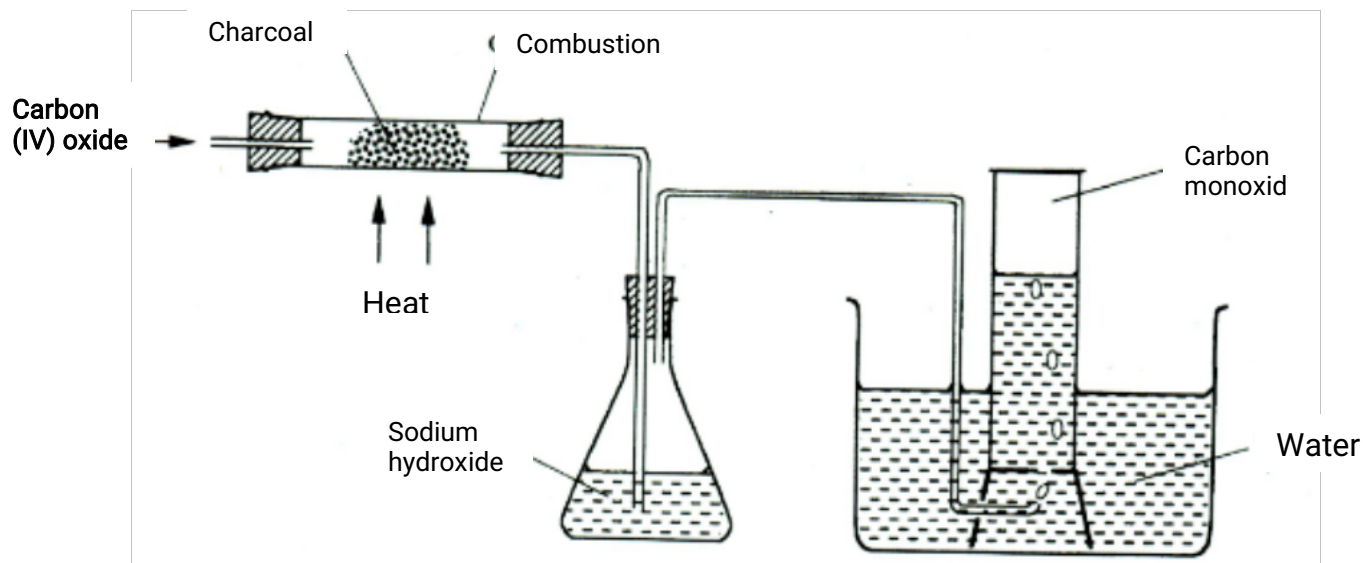

- Write an equation for the reaction that took place in the combustion tube
- Name another substance that can be used instead of sodium hydroxide
- Describe a sample chemical test that can be used to distinguish between carbon dioxide and carbon monoxide
- Give one use of carbon monoxide

7 (a) A student was supplied with a colourless liquid suspected to be water

- Describe one chemical test that could have been used to show that the liquid was water
- How could it have been shown that the liquid was pure water?

(b) The flow chart below shows the various stages of water treatment. Study it and answer the questions that follow

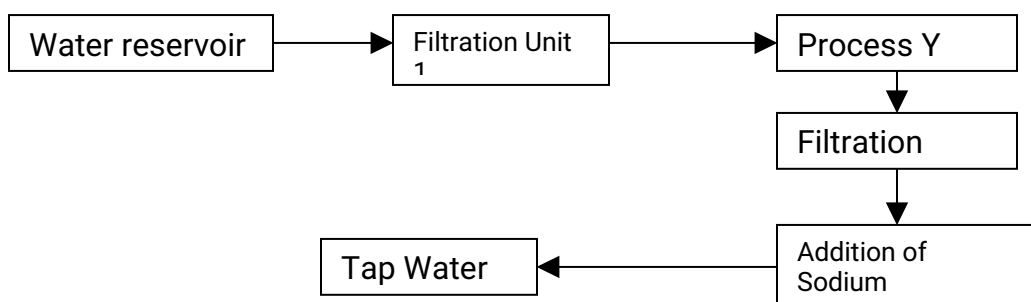

- (i) Which substances are likely to be removed in filtration unit I?
  - (ii) What is the name of the process Y?
  - (iii) What is the purpose?
    - I Process Y
    - II Addition of sodium hypochlorite
- (c) It was confirmed that magnesium sulphate was present in the tap water
- (i) What type of hardness was present in the water?
  - (ii) Explain how the hardness can be removed

## CHEMISTRY PAPER 233/2

### K.C.S.E 2001 QUESTIONS

1. In an experiment to study the rate for reaction between duralumin (an alloy of aluminium, magnesium and copper) and hydrochloric acid, 0.5g of the alloy were reacted with excess 4M hydrochloric acid. The data in the table below was recorded.

Use it to answer the questions that follow.

Time (minutes)	Total volume of gas (cm <sup>3</sup> )
1	0
2	220
3	410
4	540
5	620
6	640
7	640

- a) i) On the grid provided, plot a graph of total volume of gas produced (vertical axis) against time.  
ii) From the graph, determine the volume of gas produced at the end of 2 ½ minutes.
- b) Determine the rate of reaction between the 3<sup>rd</sup> and 4<sup>th</sup> minute.
- c) Give a reason why some solid remained at the end of the experiment
- d) Given that 2.5cm<sup>3</sup> of the total volume of the gas was from the reaction between magnesium and aqueous hydrochloric acid, calculate the percentage mass of aluminium present in 0.5g of the alloy.  
(Al = 27.0 and Molar gas volume = 24,000cm<sup>3</sup> at 298k)
- e) State two properties of duralumin that make it more suitable than aluminium in aeroplane construction.
2. a) In which homologous series do the following compounds belong  
i) CH<sub>3</sub>CC  
ii) CH<sub>3</sub>CH<sub>2</sub>COO
- b) Raw rubber is heated with sulphur in the manufacture of natural rubber.

- i) What is the name given to the process  
 ii) Why is the process necessary?
- c) Study the scheme given below and answer the questions that follow.

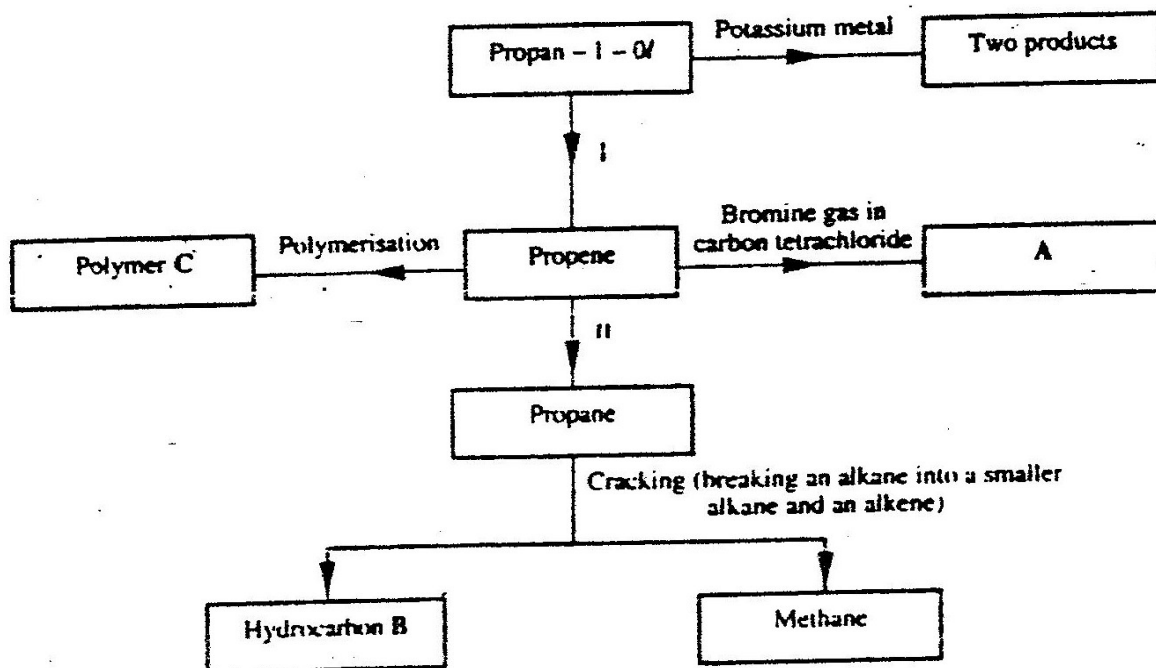

- i) Write an equation for the reaction between propan-1-ol and potassium metal.
- ii) Name processes I and II  
 I  
 II
- iii) Identify the products A and B
- iv) Name one catalyst used in process II
- v) Draw the structural formula of the repeating unit in the polymer C.
- d) State two industrial uses of methane.



3. a) Study the standard electrode potentials do the half – cells given below and answer the questions that follow. (The letters do not represent the actual symbols of the elements.)

	<b>E°volts</b>
$N^+_{(aq)} + e^- \rightleftharpoons N(s);$	-2.92
$J^+_{(aq)} + e^- \rightleftharpoons J(s);$	+0.52
$K^+_{(aq)} + e^- \rightleftharpoons \frac{1}{2} K_2(g)$	0.00
$\frac{1}{2} G_2(g) + e^- \rightleftharpoons G(aq);$	+1.36
$M^{2+}_{(aq)} + 2e^- \rightleftharpoons M(s);$	-0.44

- i) Identify the strongest oxidizing agent. Give a reason for your answer.  
 ii) Which two half – cells would produce the highest potential difference when combined?  
 iii) Explain whether the reaction represented below can take place.  
 $2N^+_{(aq)} + M(s) \longrightarrow 2N(s) + M^{2+}_{(aq)}$

- b) 100cm<sup>3</sup> of 2M sulphuric acid was electrolysed using the set – up represented by the diagram below.

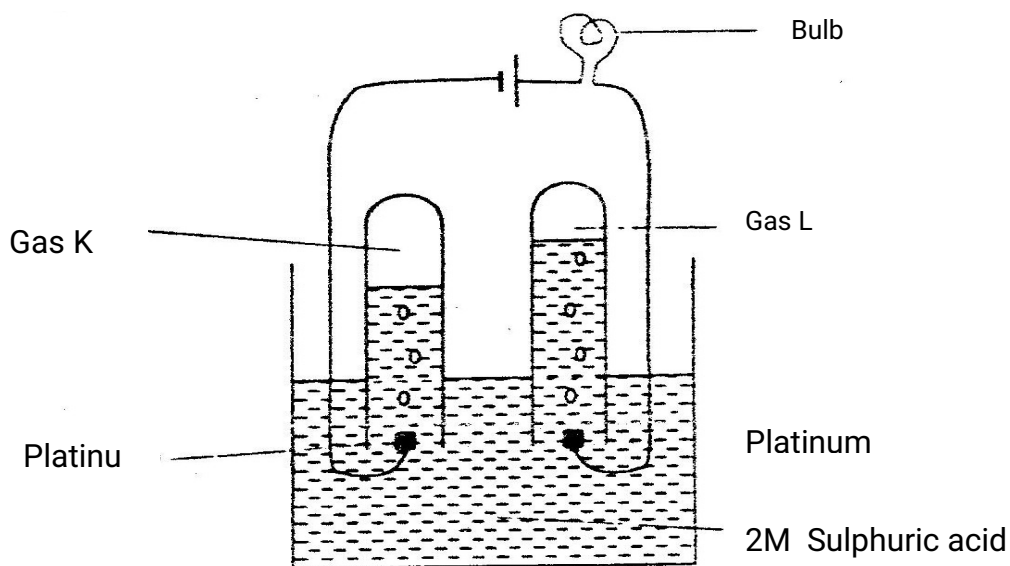

- i) Write an equation for the reaction that produces gas L.
  - ii) Describe how gas K can be identified
  - iii) Explain the difference in :
    - I The volume of the gases produced at the electrodes.
    - II Brightness of the bulb if  $100\text{cm}^3$  of 2M ethanoic acid was used in place of sulphuric acid.
4. a) Fraction distillation of liquid air usually produces nitrogen and oxygen as the major products.
- i) Name one substance that is used to remove carbon dioxide from the air before it is changed into liquid.
  - ii) Describe how nitrogen gas is obtained from the liquid air.  
(Boiling points nitrogen =  $-196^\circ\text{C}$ , oxygen =  $-183^\circ\text{C}$ )

b) Study the flow chart below and answer the questions that follow.

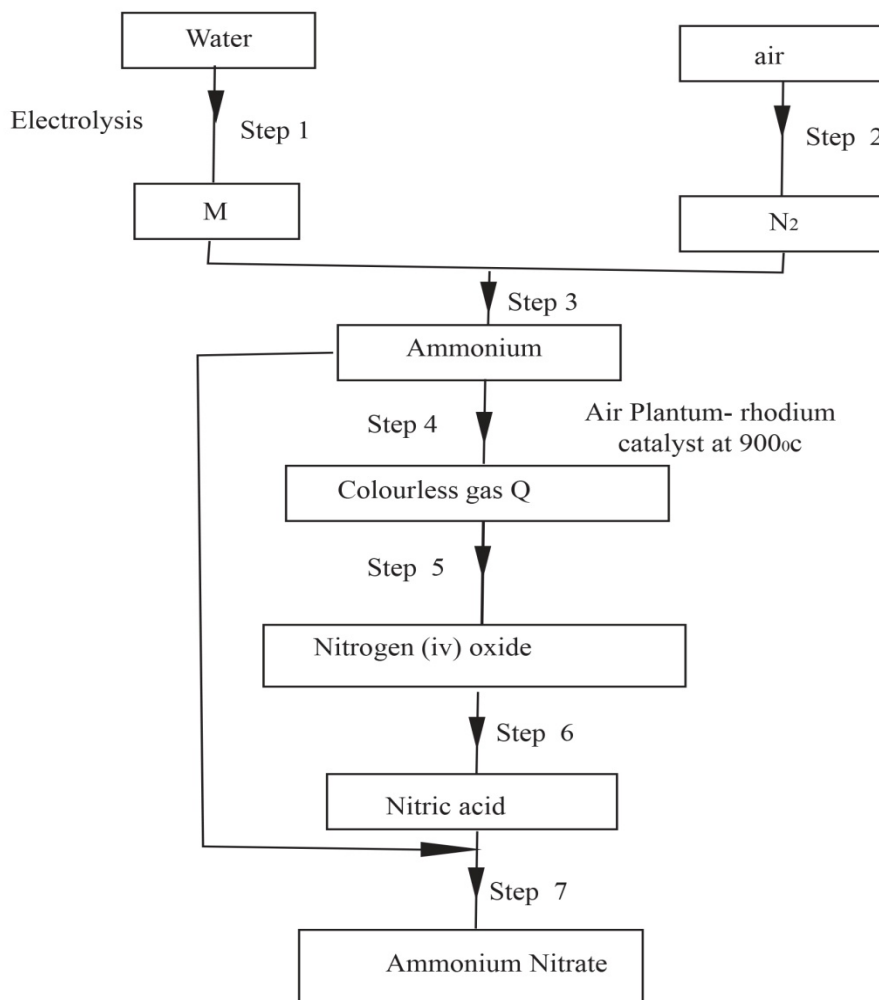

- Name element M.
  - Why is it necessary to use excess air in step 4?
  - Identify gas Q.
  - Write an equation for the reaction in step 7
  - Give one use of ammonia nitrate.
- c) State and explain the observations that would be made if a sampler of sulphur is heated with concentrated nitric acid.

5. a) Give the name of reagent which when reacted with concentrated hydrochloric acid produce chlorine gas.
- b) A student out to prepare iron III chloride using the apparatus shown in the diagram below.

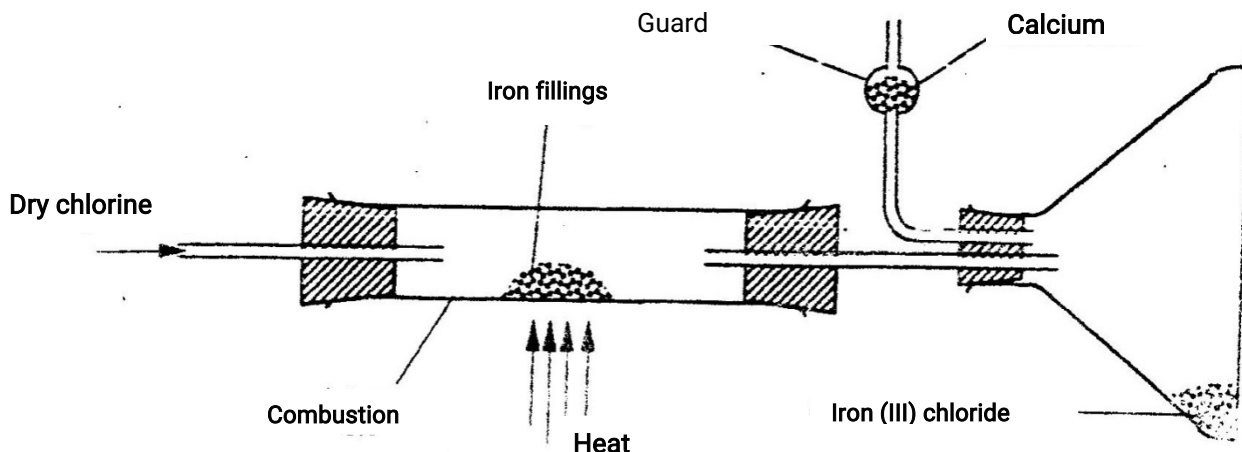

- i) Explain why:
- I. It is necessary to pass chlorine gas through the apparatus before heating begins.
  - II. Calcium oxide would be preferred to calcium chloride in the guard tube.
- ii) What property of iron (III) chloride makes it possible to be collected as shown in the diagram?
- iii) Write an equation form one chemical reaction that took place in the guard tube.
- iv) The total mass of iron (III) chloride formed was found to be 0.5g. Calculate the volume of chlorine gas the reacted with iron.  
(Fe = 56.0, Cl = 35.5 and Molar gas volume at 298K is 24,000cm<sup>3</sup>)
- C) When hydrogen sulphide gas was passed through a solution of iron (III) chloride, the following observation were made:
- i) The colour of the solution changed from reddish – brown to green
  - (ii) a yellow solid was deposit .Explain these observations.
- d) State and explain the observations that would be made if a moist blue litmus paper was placed in a gas jar full of chloride gas.

6. a) Study the information in the table below and answer the questions that follow. (The letters do not represent the actual symbols of the elements).

Ionisation Element	Electronic configuration	Energy KJ mol <sup>-1</sup>
P	2.1	519
Q	2.8.1	494
R	2.8.8.1	418

- i) What is the general name to the group in which elements P,Q and R belong?
- ii) What is meant by ionization energy?
- iii) Explain why elements has the highest ionization energy.
- iv) When a piece of element Q is placed on water. It melts and a hissing sound is produced as it moves on the surface of the water.
- v) Write an equation for the reaction between element Q and water.
- b) Distinguish between a strong and a weak base. Give an example of each
- c) Neutralization is one of the methods of preparing salts.
- i) What is meant by neutralization?
- ii) Describe how you would prepare crystals of sodium nitrate starting with 200cm<sup>3</sup> of 2M sodium hydroxide.
- iii) Write an equation for the reaction that takes place when a solid sample of sodium nitrate is heated.

**CHEMISTRY PAPER 233/2**  
**K.C.S.E 2002 QUESTIONS**

1. (a) what method can be used to separate a mixture of ethanol and propanol?
- (b) (i) Explain how a solid mixture of sulphur and sodium chloride can be separated into solid sulphur and solid chloride
- (c) The table below gives the solubilities of potassium bromide and potassium sulphate at 0°C and 40°C

Substance	Solubility g/100g water at	
	0°C	40°C
Potassium bromide	55	75
Potassium sulphate	10	12

When an aqueous mixture containing 60g of potassium and 7 g of potassium sulphate in 10g of water at 80°C was cooled to 0°C some crystals were formed

- (i) Identify the crystals
- (ii) Determine the mass of the crystals formed
- (iii) Name the method used to obtain the crystals
- (iv) Suggest one industrial application of the method named in (iii) above

2. Study the flow chart below and answer the questions follow

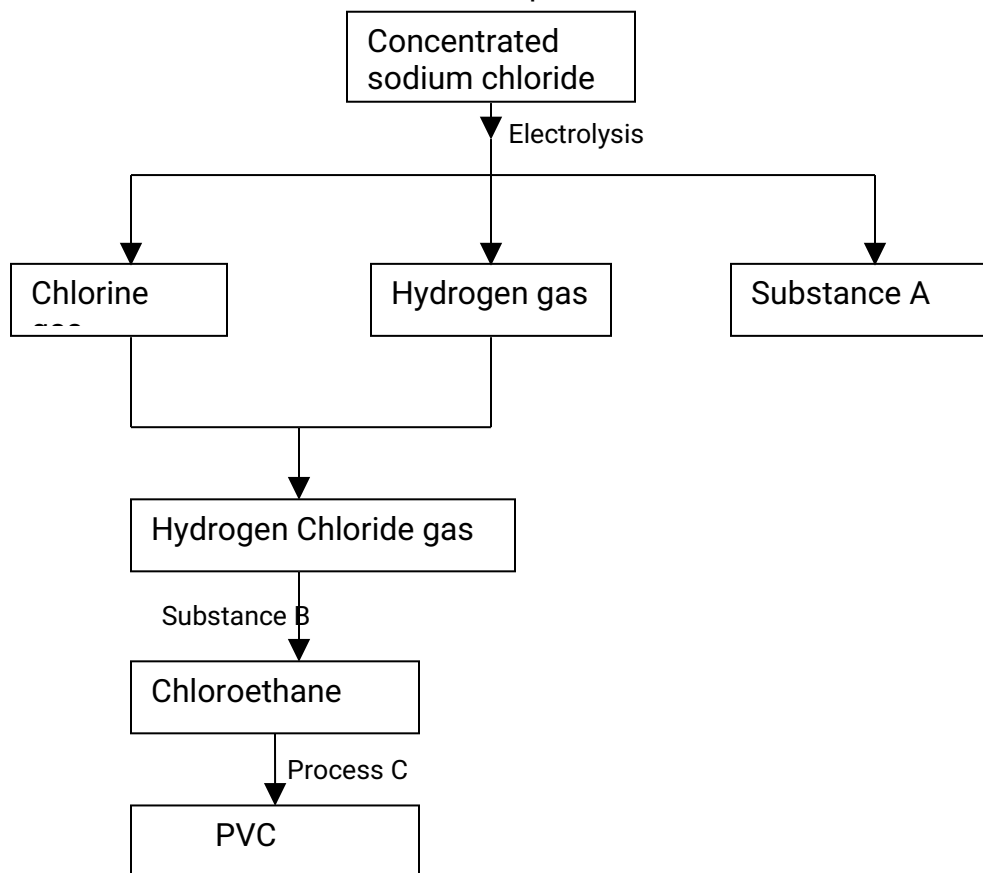

(a) Identify substance

- (i) A
- (ii) B

(b) Name process C

(c) Give one use of PVC

(d) Write an equation for the reaction in which chlorine gas is produced

(e) State and explain the observation that would be made if chlorine gas was bubbled into an aqueous solution of sodium iodide

(f) In the preparation of a bleaching agent (Sodium hypochlorite), Excess chlorine gas was bubbled into 15 litres of cold 2 m sodium hydroxide

(i) Write an equation for the reaction between chlorine gas and cold dilute sodium Hydroxide

(ii) Calculate the:

Number of moles of sodium hydroxide used

Mass in kilograms of the sodium hypochlorite produced = 1.1175

3. (a) Distinguish between exothermic and endothermic reaction (2mks)

(b) Changes of state are either exothermic or endothermic

Name a change of state that is:

(i) Endothermic

(1 mk)

(ii) Exothermic

(1 mk)

(c) When pure water is heated at 1 atmospheric pressure at sea level, the temperature of the water does not rise beyond  $100^{\circ}\text{C}$ . Even with continued heated. Explain this observation.

(d) Study the energy cycle diagram below and answer the questions that follow

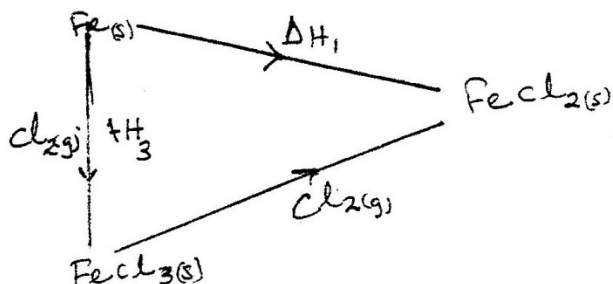

(i) What does  $\Delta H_1$  represent?

(ii) Show the relationship between  $\Delta H_1$ ,  $\Delta H_2$  and  $\Delta H_3$

(e) Butane and propane are constituents of a cooking gas. Which produces more energy per mole on combustion? Explain

4. The table below gives standard electrode potentials for the metals represented by the Letters D, E, F and G. study it and answer the questions that follow.

Metals	Standard electrode potential (volts)
D	-0.13
E	-0.85
F	+0.34



G

- 0.76

(a) Which metal can be displaced from a solution of its salts by all the other metals in the table? Give a reason (2 mks)

(b) Metals F and G were connected to form a cell as shown in the diagram below

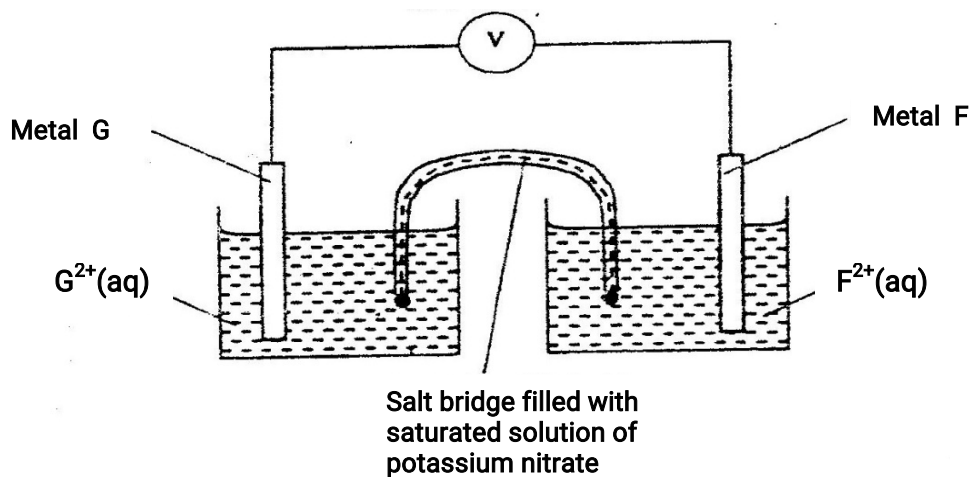

(i) Write the equation for the reactions that occur at electrodes

F

G

(ii) On the diagram, indicate with an arrow the direction in which electrons would flow on the diagram above

(ii) What is the function of the salt bridge?

(1 mk)

(c) An electric current was passed through a concentrated solution of copper (II) chloride as shown in the diagram below

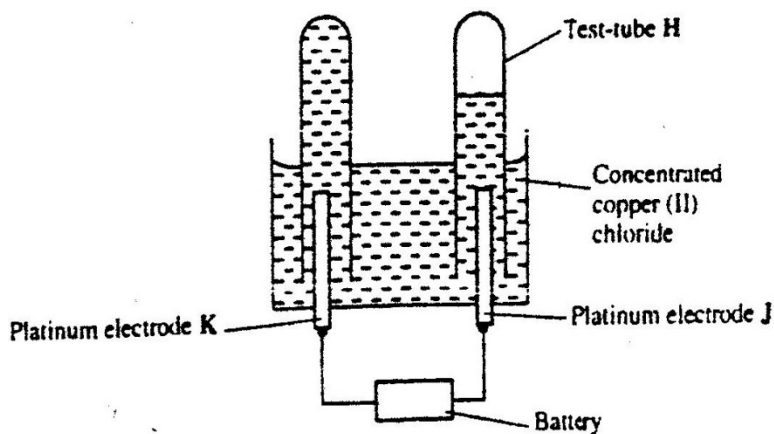

(i) Explain the observation that would be made on the electrolyte as the

experiment progresses

(2 mks)

(ii) After sometime, test- tube H was found to contain a mixture of two gases.

Explain this observation  
(3 mks)

(3

(iii) Which of the electrodes is the anode? Explain  
(2 mks)

(2

5. (a) Candle wax is mainly a compound consisting of two elements.

Name the two elements

(2 mks)

(b) The set- up below was used to investigate the burning of a candle study it and answers the questions that follow

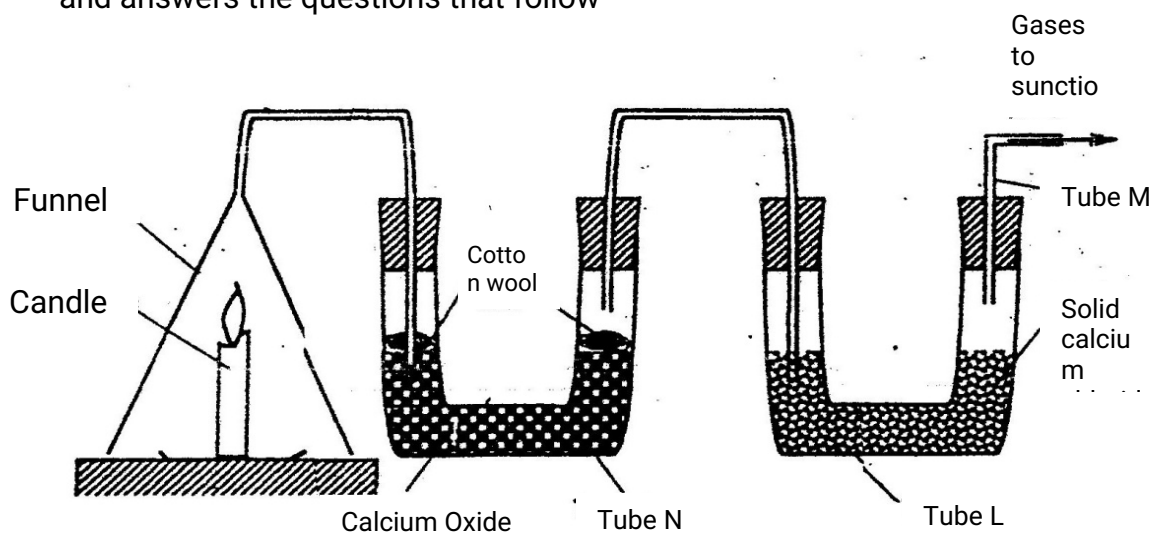

(i) What would happen to the burning candle if the pump was turned off?  
Give reasons

(ii) State and explain the changes in mass that are likely to occur in tube N by the end of the experiment

(3 mks)

(iii) Name two gases that come out through tube M  
(2 mks)

(2

(iv) Name another substance that could be used in the place of calcium oxide in tube N

6. (a) Name one ore from which copper metal is extracted

(1 mk)

(b) The chart below shows a sequence of reactions starting with copper. Study it and answer the questions that follow

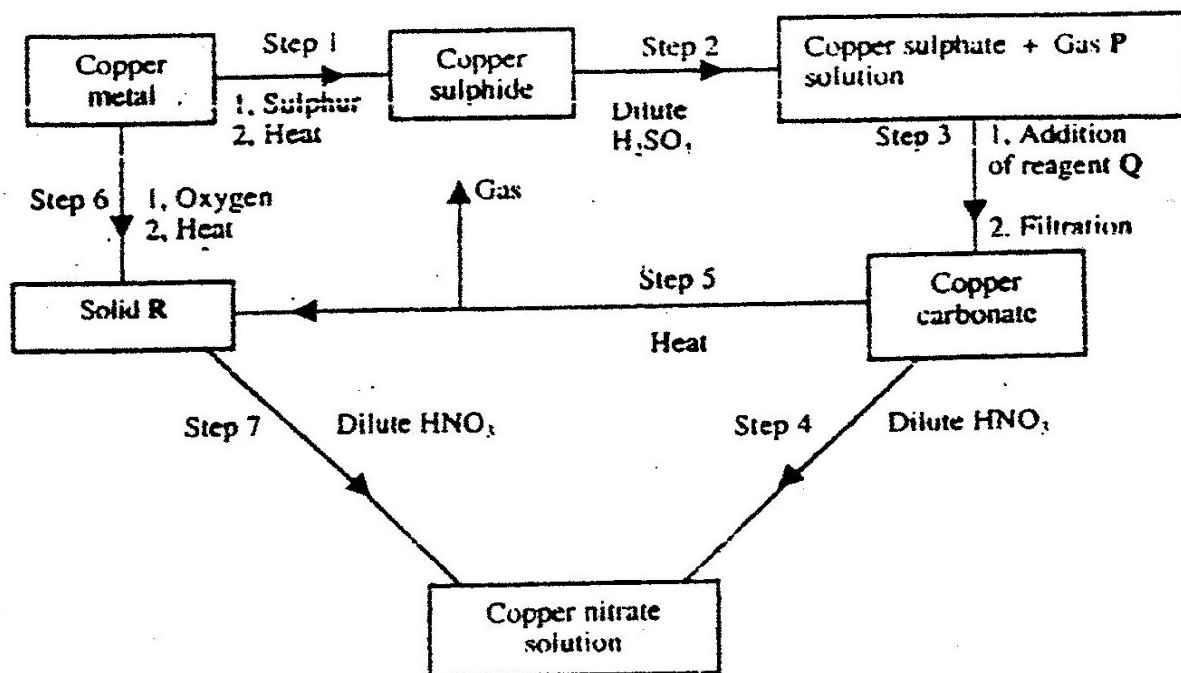

(i) Identify

Gas P

Reagent Q

(1 mk)

Solid R

(1mk)

(1 mk)

(ii) Write an equation for the reaction that takes place in step 5

(2mk)

(iii) State the observations made in steps 4 and 7

(2 mk)

Step 4

Step 7

(c) Bronze is an alloy of copper and another metal

(i) Name the other metal

(1mk)

- (ii) Give one use of Bronze (1mk)
6. (a) Write the structural formula of:  
(i) Methanol  
(ii) Methanoic acid (1mk)
- (b) Write the equation for the reaction between methanoic acid and aqueous sodium hydroxide (1mk)
- (c) (i) Name the product formed when methanol reacts with methanoic acid  
(ii) State one condition necessary for the reaction in (c) (i) above to take place
- (d) (i) Describe one chemical test that can be used to distinguish between hexane and hexane (2 mks)  
(ii) State one use of hexane (1mk)  
(iii) Hydrogen reacts with hexane to form hexane. Calculate the volume of hydrogen gas required to convert 42g of hexane to hexane at S.T.P (C=12.0, H=1.0, molar gas volume at S.T.P is = 22.4 litres) (4 mks)

# CHEMISTRY PAPER 233/2

## K.C.S.E 2003 QUESTIONS

1. a) The chart below is an outline of part of the periodic table.

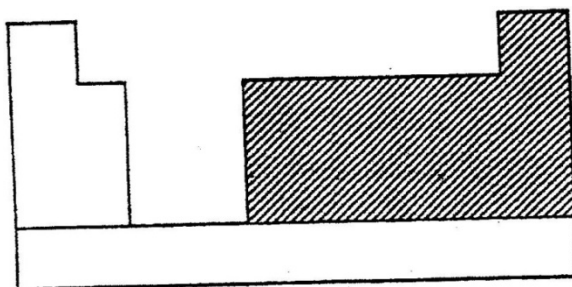

- i) With the help of vertical and horizontal lines, indicate the direction of increasing metallic nature of the elements.  
(2mks)
- ii) Which types of elements are represented in the shaded area?  
(1mk)
- b) i) Element A is the same group of the periodic table as chlorine. Write the formula of the compound formed when A reacts with potassium metal. (1mk)
- ii) What type of bonding exists in the compound formed in (b) (i) above? Give a reason for your answers. (3mks)
- c) Starting with aqueous magnesium sulphate, describe how you would obtain a sample of magnesium oxide. (3mks)
- d) Write two ionic equations to show that aluminium hydroxide is amphoteric (2mk)

2. a) The diagram below is a cross-section of a dry cell. Study it and answer the questions that follow.

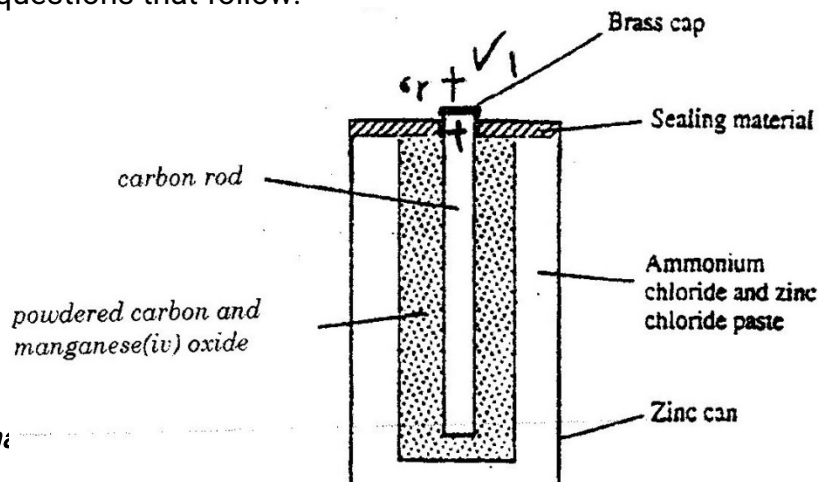

For m:

- i) On the diagram, show with a (+) sign the positive terminal
- ii) Write the equation for the reaction in which electrons are produced
- iii) The zinc can is lined with ammonium chloride and zinc chloride paste.
- iv) Give one advantage and one disadvantage of dry cells.

b) The set – up below was used to (*electrolyse roller lead (II) ionide*).

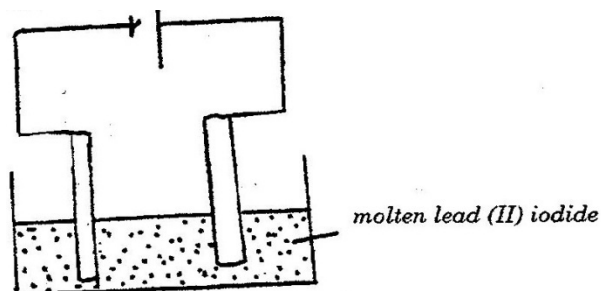

- i) State the observation that was made at the anode during the electrolysis. Give a reason for your answer. (2mk)
- ii) A current of 0.5 A was passed for two hours. Calculate the mass of lead that was deposited (pb = 1F = 9,500C) (3mks)

3. a) State two differences between chemical and nuclear reactions (2mks)

b) Below is a radioactive decay series starting from  ${}_{83}^{214}\text{Bi}$  and ending at  ${}_{82}^{206}\text{Pb}$ . Study it and answer the question that follows.

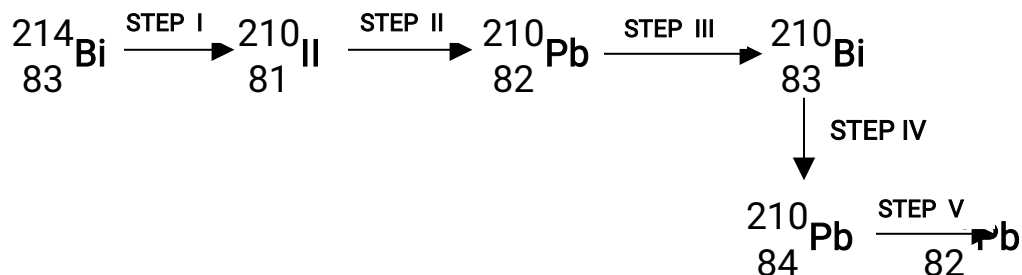

- i) Identify the particles emitted in steps I and III (2mks)
  - I
  - II

- ii) Write the nuclear equation for the reaction which takes place in step V (1mk)

The table below give the percentages of a radioactive isotope of Bismuth that remains after decaying at different times.

Time (min)	0	6	12	22	38	62	100
Percentage of Bismuth	100	81	65	46	29	12	3

- i) On the grid provided, plot a graph of the percentage of Bismuth remaining (Vertical axis) against time.

- ii) Using the graph, determine the:

I. Half – life of the Bismuth isotope

II. Original mass of the Bismuth isotope given that the mass that remained after 70 minutes was 0.16g (2mks)

- d) Give one use of radioactive isotopes in medicine (1mk)

4. Excess marble chips (calcium carbonate ) was put in a beaker containing  $100\text{cm}^3$  of dilute hydrochloric acid. The beaker was then placed on a balance and the total loss in mass recorded after every two minutes as shown in the table below.

Time(min)	0	2	4	6	8	10
Total loss in mass (g)	0	1.8	2.45	2.95	3.2	3.3

- a) Why was there a loss in mass? (1mk)
- b) Calculate the average rate of loss in mass between:
- i) 0 and 2 minutes (1mk)
- ii) 6 and 8 minutes (1mk)
- iii) Explain the difference in the average rates of reaction in (b) (i) and (ii) above (2mks)

- c) Write the equation for the reaction which takes place in the beaker
- d) State three ways in which the rate of the reaction above could be increased (3mks)
- e) The solution in the beaker was evaporated to dryness what would happen if the open beaker and its contents were left in the laboratory overnight. (2mks)
- f) Finally some water was added to the contents of the beaker. When aqueous sodium sulphate was added to the contents of the beaker, a white precipitate was formed. (1mk)
- i) Identify the white precipitate
- ii) State one use of the substance identified in (f) (i) above (1mk)

5. The basic raw material for extraction of aluminium is bauxite
- a) Name the method that is used to extract aluminium from bauxite
- b) Write the chemical formula of the major component of bauxite
- c) i) Name two major impurities in bauxite (2mks)  
ii) Explain how the impurities in bauxite are removed (3mks)
- d) Cryolite is used in the extraction of aluminium from bauxite. State its function (1mk)
- f) Aluminium is a reactive metal yet utensils made of aluminium do not corrode easily. Explain this observation (2mks)

6. The set – up below was used to prepare hydrogen gas

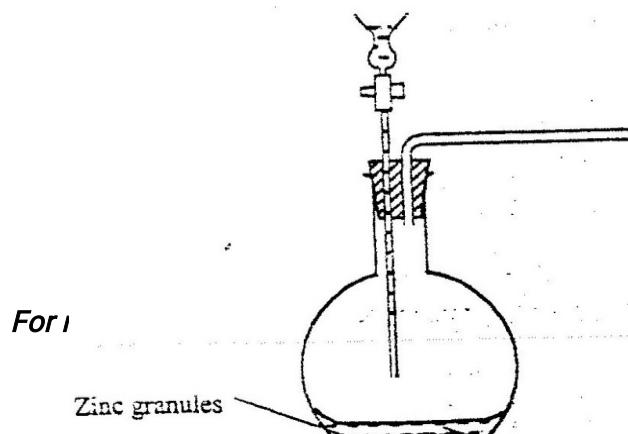



Zinc

Dilute  
sulphuric

- a) Complete the diagram to show how a dry sample of hydrogen gas can be collected (3mks)
- b) Write an equation for the reaction, which takes place when hydrogen gas burns in air. (1mk)
- c) i) 1.2 litres of hydrogen gas produced at room temperature and pressure when 3.27g of zinc was used. Determine the relative atomic mass of zinc. (Molar gas volume is 24 litres) (4mks)
- d) State two industrial uses of hydrogen gas.
7. a) State how burning can be used to distinguish between ethane and ethyne. Explain your answer. (3mks)
- b) Draw the structural formula of the third member of the homologous series of ethyne.
- c) The flow chart below shows a series of reactions starting with ethanoic acid. Study it and answer the questions that follow

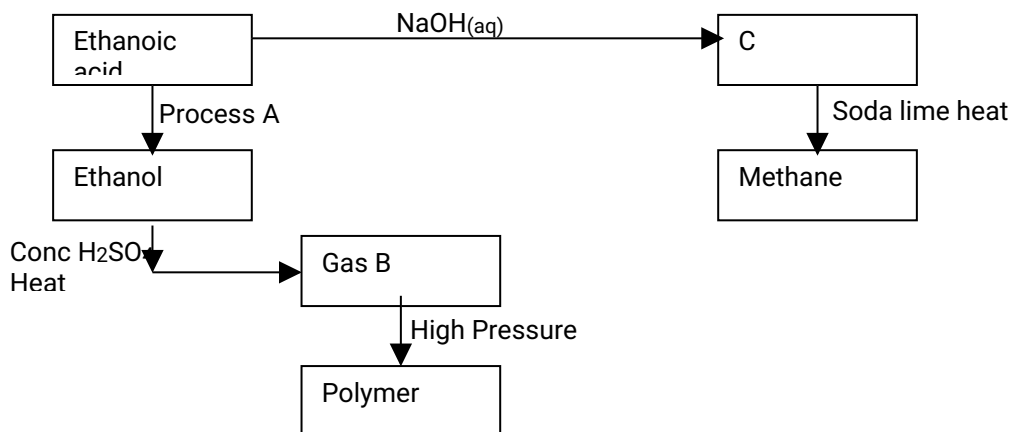

- i) Name :  
I. Process A

II. Substances B and C

B

C

(1mk) ii) Write the equation for the combustion of ethanol

iii) Explain why it is necessary to use high pressure to change gas B into the polymer (1mk)

iv) State one use of methane (1mk)

## CHEMISTRY PAPER 233/2

### K.C.S.E 2004 QUESTIONS

1. a) The table below shows properties of chlorine, bromine and iodine.

Element	Formula	Colour and state room temperature	Solubility
Chlorine	Cl <sub>2</sub>	i).....	Soluble
Bromine	Br <sub>2</sub>	Brown liquid	ii).....
Iodine	I <sub>2</sub>	iii) .....	Slight soluble

Complete the table by giving the missing information in (i),(ii) and (iii)  
(3mks)

- b) Chlorine gas is prepared by reacting concentrated hydrochloric acids with manganese (iv) oxide.
- i) Write the equation for reaction between concentrated hydrochloric acid and manganese (iv) oxide. (1mk)
- ii) What is the role of manganese (iv) oxide in this reaction  
(1mks)
- c) i) Iron (II) chloride reacts with chlorine gas to form substance E.  
(1mk)  
Identify substance E
- ii) During the reaction in c(i) above, 6.30g of iron chloride were converted to 8.06 of substance E. Calculate the volume of chlorine used.  
(Cl = 35.5, Molar gas volume at room temperature = 24000cm<sup>3</sup>, Fe = 56)  
(2mks)
- d) Draw and name the structure of the compound formed when excess chlorine gas is reacted with ethane gas. (2mks)
- e) Give the industrial use of chlorine (1 mk)
2. a) The set-up below was used to collect gas F, produced by the reaction between water and calcium metal.

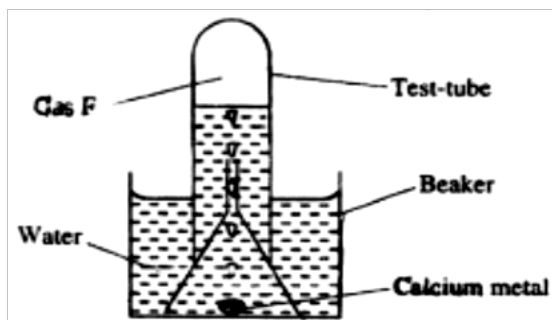

- (i) Name gas f
- (ii) At the end of the experiment, the solution in the beaker was found to be a weak base. Explain why the solution is a weak base. (2 mks)
- (iii) Give one laboratory use of the solution formed in a beaker. (1 mk)
- (b) The scheme below shows some reactions starting with calcium oxide. Study it and answer the questions that follow.

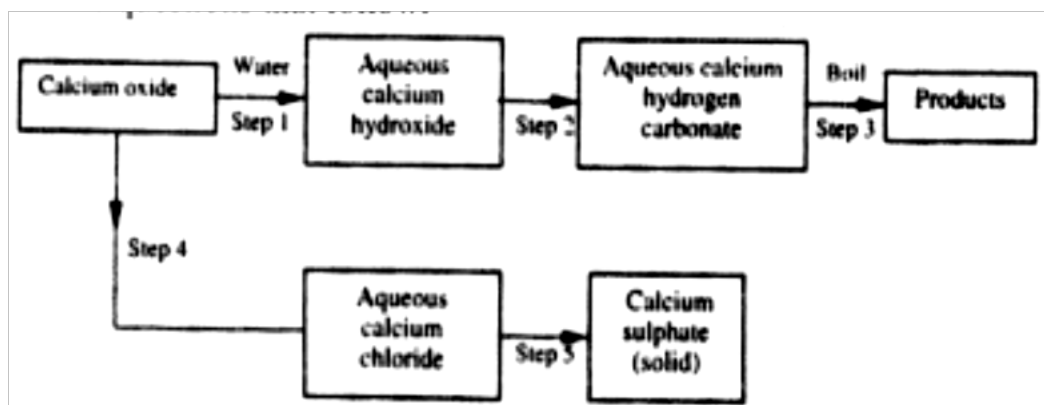

- (i) Name the reagents used in steps 2 and 4 (2mks)  
 Step 2 .....  
 Step 4 .....
- (ii) write an equation for the reaction in step 3. (1 mk)
- (iii) Describe how a solid sample of anhydrous calcium sulphate is obtained in Step 5
3. a) The diagram below illustrates how sulphur/extracted by the Frisch process.

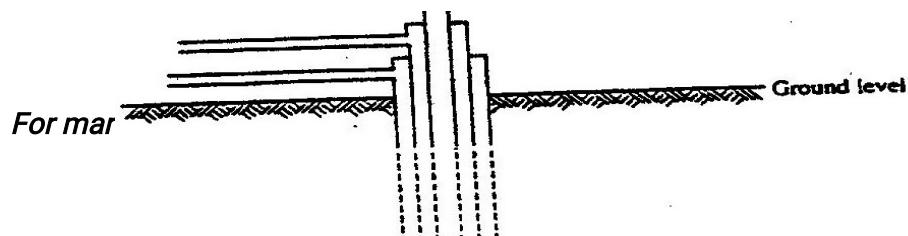

Label the pipe through which superheated water is pumped in  
(1mk)

- b. The equation below shows the oxidation of sulphur dioxide to sulphure trioxide in the contact process.



- (i) Name one catalyst for this reaction  
(1 mk)
- (ii) State and explain the effect on the yield of sulphur trioxide when:  
I The temperature increased (2mks)  
II The amount of oxygen is increased (2mks)
- (iii) Describe how sulphur trioxide is converted to sulphuric acid in the contact process. (2 mks)
- (c) State two disadvantages of having sulphur dioxide in the environment (2mks)
- (d) Ammonia sulphate is a fertilizer produced by passing ammonia gas into concentrated sulphuric acid.
- (i) Write the equation for the reaction (1mk)
- (ii) Calculate the mass in Kg of sulphuric acid required to produce 25kg of the fertilizer (S= 32.0; O= 16.0; N = 1.0)

4. a) at 250C , 50g of potassium were added to 100gm of water to make a saturated solution. What is meant by a saturated solution?  
(1 mk)

- b) The table below gives the solubilities of potassium nitrate at different temperatures.

Temperature <sup>0</sup> C	12	20	28	36	44	52
Solubility g/100g C water	22	31	42	55	70	90

- (i) Plot graph of the solubility of potassium nitrate (vertical axis) against temperature (3 mks)

- (ii) Using the graph:

I Determine the solubility of potassium nitrate at 15<sup>0</sup>C

II Determine the mass of potassium nitrate that remained undissolved given that 80g of potassium nitrate were added to 100cm<sup>3</sup> of water and warmed to 40<sup>0</sup>C.

- c) Determine the molar concentration of potassium nitrate at 15<sup>0</sup>C (3mks)  
(Assume there is no change in density of water at this temperature)  
(K = 39. 0; N= 14.0; O = 16.0)

5. The flow chart below shows some reactions starting with lead (II) nitrate. Study it and answer the questions that follow.

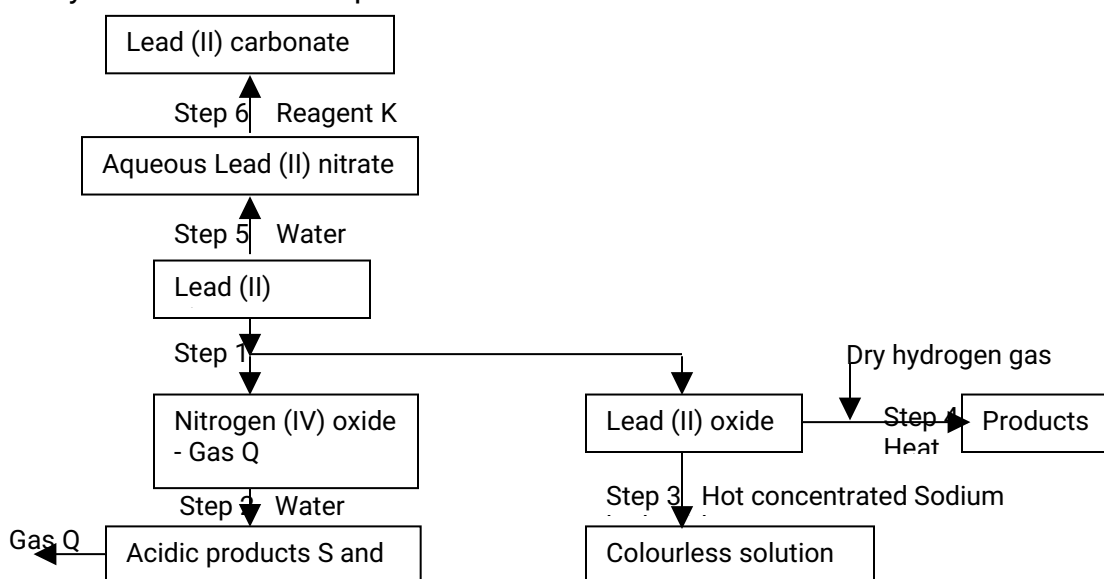

- (i) State the condition necessary in step 1.
- (ii) Identify:  
 I Reagent K  
 II Gas q  
 III Acidic products S and R
- (iii) Write:  
 I The formula of the complex ion formed in step 3.  
 II The equation of the reaction in step 4 (1 mk)
- (1mk)
- b) The use of materials made of lead in roofing and in water pipes is being discouraged  
 State:  
 (i) Two reasons why these materials have been used in the past. (2mks)  
 (ii) One reason why their use is being discouraged
- c) (i) The reaction between lead (II) nitrate and concentrated sulphuric acid starts but stops immediately. Explain (2mks)
6. a) Crude oil is a source of many compounds that contain carbon and hydrogen only.
- (1mk)  
 (i) Name the processes used to separate the components of crude oil  
 (ii) On what two physical properties of the above components does the separation depend? (2mks)
- b) Under certain conditions, hexane can be converted to two products.  
 The formula of one of the products is  $C_3H_6$   
 (i) Write the formula of the other product (1mk)  
 (ii) Describe a simple chemical reaction to show the difference between the two products formed in (b) above. (2mks)
- c) Ethane,  $C_2H_6$  is another compound found in crude oil.  
 One mole of ethane was reacted with one mole of hydrogen chloride gas and

a product  $p_1$  and was formed.  $P_1$  was then reacted with excess hydrogen gas to form  $p_2$ . Draw the structures  $p_1$  and  $p_2$ .

- d) The set-up below was used to prepare and collect ethane gas. Study it and answer the questions that follow.

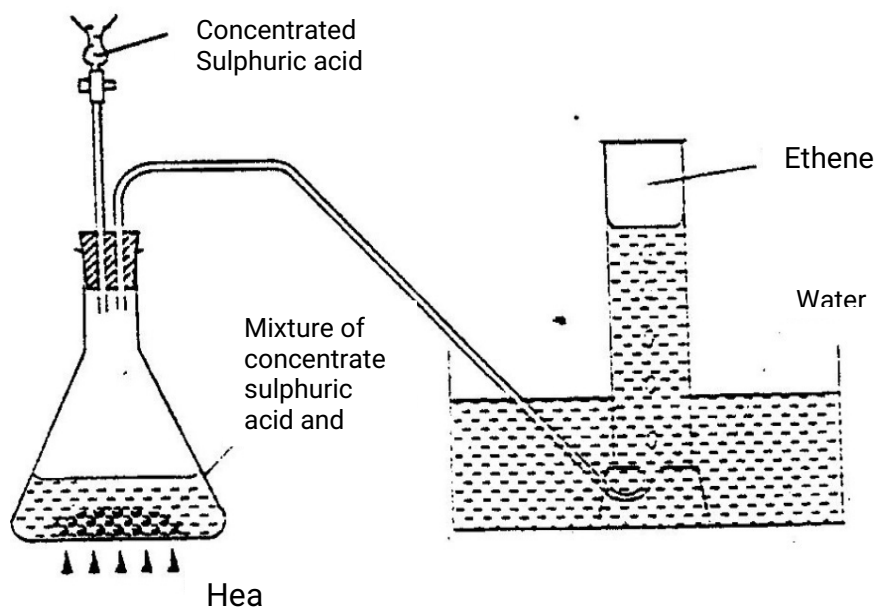

- (i) Name the substance T
- (ii) Give the property of ethane that allows it to be collected as shown in the set up.
- e) One of the reactions undergone by ethane is addition polymerization. Give the name of the polymer and one disadvantage of the polymer it forms. (2 mks)

Name the polymer.  
Disadvantage of the polymer

7. (a) Brine usually contains soluble calcium and magnesium salts. Explain how sodium carbonate is used to purify brine. (2mks)

- b) The diagram below represents a diaphragm cell used to electrolyse pure brine

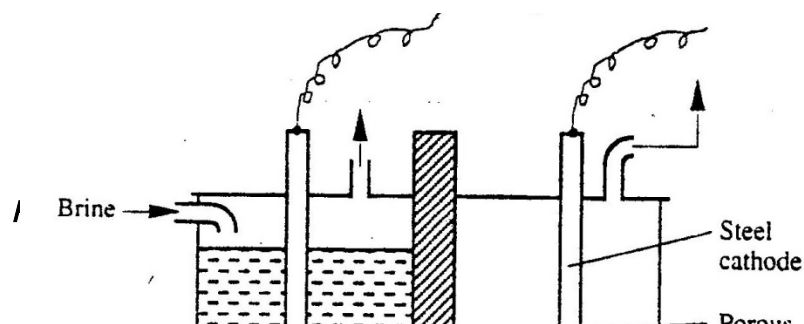



- i) Write the equations for the reactions that take place at
- |    |         |       |
|----|---------|-------|
| I  | Cathode | (1mk) |
| II | Anode   | (1mk) |
- ii) Name:
- |     |   |       |
|-----|---|-------|
| I   | Product at U  | (1mk) |
| II  | Another material that can be used instead of titanium | (1mk) |
| III | The impurity present in the product at U              |       |
- iii) State two functions of the diagram  
(2mks)
- c) Give one industrial use of the product at U.  
(1 mk)

**CHEMISTRY PAPER 233/2**  
**K.C.S.E 2005 QUESTIONS**

1. (a) The diagram below shows spots of pure substance A,B, and C on a chromatography paper. Spot D is that of a mixture

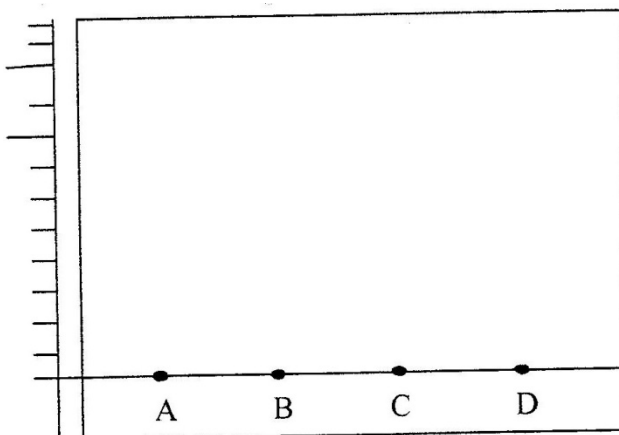

After development, A, B and C were found to have moved 8cm, 3cm and 6 cm respectively. D has separated into two spots which had moved 6cm and 8 cm

- (i) On the diagram  
I Label the baseline (origin) (1mk)  
II Show the positions of all the spots after development  
(3 mks)

- (ii) Identify the substances present in the mixture D  
(2mks)

- (b) Describe how solid ammonium chloride can be separated from a solid mixture of ammonium chloride and anhydrous calcium chloride  
(2mks)

- (c) The table shows liquids that are miscible and those that are immiscible

Liquid	L <sub>3</sub>	L <sub>4</sub>
L <sub>1</sub>	Miscible	Miscible
L <sub>2</sub>	Miscible	Immiscible

Use the information given to answer the questions that follow

- (i) Name the method that can be used to separate L<sub>1</sub> and L<sub>3</sub> from a mixture of two (1 mk)
- (ii) Describe how a mixture of L<sub>2</sub> and L<sub>4</sub> can be separated  
(2mks)

2. (a) Name one raw material which sodium hydroxide is manufactured  
(1 mk)

(b) Sodium hydroxide pellets were accidentally mixed with sodium chloride 17.6 g of the mixture were dissolved in water to make one litre of solution. 100 cm<sup>3</sup> of the mixture were dissolved in water to make one litre solution. 100cm<sup>3</sup> of the solution was neutralized by 40cm<sup>3</sup> of 0.1M sulphuric acid

- (i) Write an equation for the reaction that took place
- (ii) Calculate the:  
(i) Number of moles of the substance that reacted with sulphuric acid  
(2mks)

(ii) Number of moles of the substances that would react with sulphuric acid in the one litre of solution (1mk)

(iii) Mass of the unreacted substances in one litre of solution (2mks)

(H = 1,0 ; Na = 23.0 ; Cl= 35.5 ; O= 16.0)

(c) The diagram below shows an incomplete set-up used to prepare and collect ammonia gas

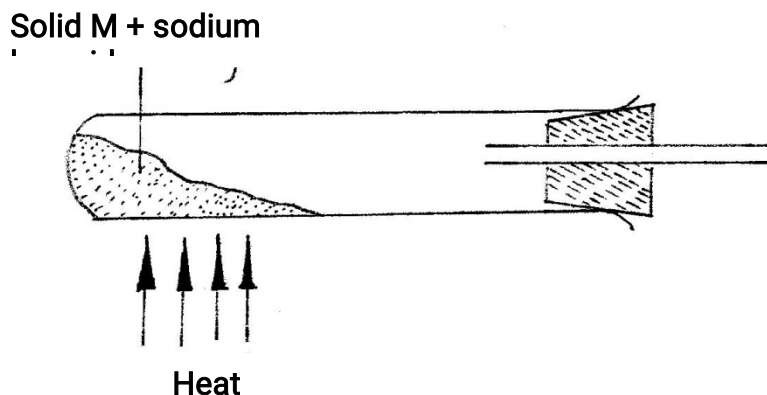

(1mk)

(i) Name solid M

(ii) Complete the diagram to show how a dry sample of ammonia gas can be collected

(3mks)

(d) In an experiment, excess ammonia gas passed over heated copper (II) oxide on a combustion tube.

(i) State the observation that was made in the combustion tube at the end of the experiment

(1 mk)

(ii) What property of ammonia is shown in the above reaction

(1 mk)

(iii) Name one use of ammonia

(1 mk)

3. (a) The table below shows the standard reduction potentials for four half-cells. Study it and answer the questions that follow. (Letters are not the actual symbols of the elements)

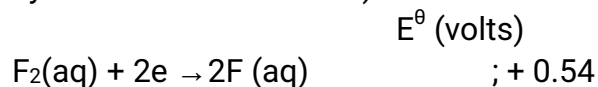

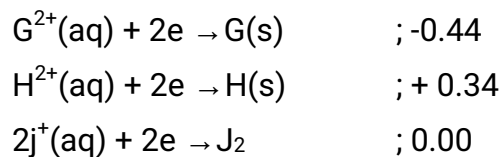

(i) Identify the strongest reducing agent (1 mk)

(ii) Write the equation for the reaction which takes place when solid G is added to a solution containing  $H^{2+}$  ions (1 mk)

(iii) Calculate the  $E^{\ominus}$  value for the reaction in (ii) above (1mk)

(b) The diagram below shows the apparatus that can be used to electrolyze acidified water to obtain hydrogen and oxygen gases. Study it and answer the questions that follow

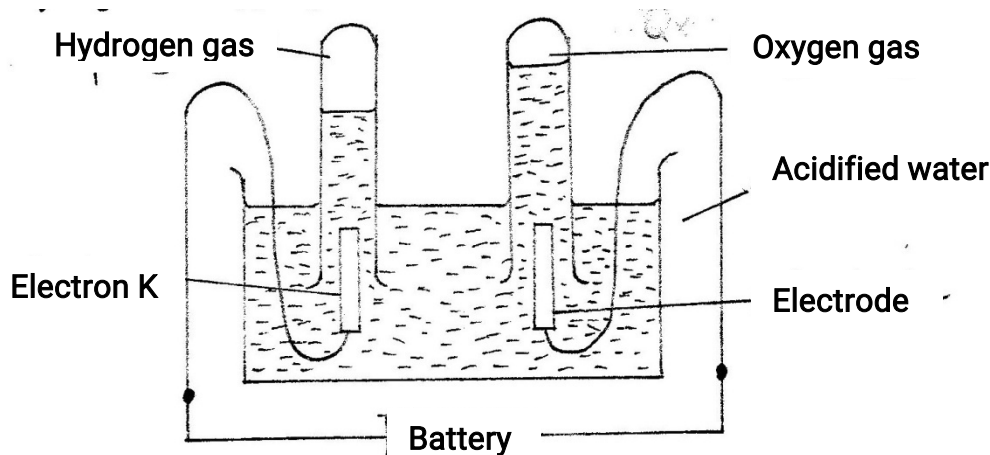

(i) Identify the electrode at which oxidation takes place

(1 mk)

(ii) Give a reason why it is necessary to acidify the water

(1mk)

(iii) Explain why hydrochloric acid is not used to acidify the water

(2mks)

(c) During electrolysis of aqueous copper (II) sulphate, 144750 coulombs of electricity were used.

Calculate the mass of copper metal that was obtained

$Cu = 64$  ; 1 Faraday = 96500 coulombs

(3mks)

4. (a) An atom Q can be represented as

52

Q

24

What does the number 52 represent?

(1mk)

- (b) Study the information in the table below and answer the equations that follow  
(Letters are not the actual symbols of the elements)

Element	Electronic Arrangement of stable ion	Atomic Radius (nm)	Ionic Radius (nm)
N	2.8.8	0.197	0.099
P	2.8.8	0.099	0.181
R	2.8	0.160	0.065
S	2.8	0.186	0.095
T	2	0.152	0.068
U	2.8	0.072	0.136

- (i) Write the formula of the compound formed when N reacts with P.  
(atomic numbers are N = 20; P = 17)  
(1 mk)
- (ii) Identify the elements which belong to the third period of the periodic table. Explain  
(2mks)
- (iii) Which of the element identified in b (ii) above comes first in the third period? Explain  
(2mks)
- (iv) Select two elements which are non- metals  
(1 mk)
- (c) The table below gives some properties of substances I, II, III, and IV. Study it and answer the questions that follow

Substance	Electrical conductivity		M.P ( <sup>o</sup> C)	B.P ( <sup>o</sup> C)
	Solid	Molten		
I	Does not conduct	Conducts	801	1420
II	Conducts	Conducts	650	1107
III	Does not conduct	Does not conduct	1700	2200
IV	Does not conduct	Does not conduct	113	440

(i) What type of bonding exists in substances I and II  
(2mks)

I  
II

(ii) Which substances is likely to be sulphur? Explain (2mks)

5. In an experiment, a piece of magnesium ribbon was cleaned with steel wool. 2.4 g of the clean magnesium ribbon was placed in a crucible and completely burnt in oxygen. After cooling, the product weighed 4.0 g

(a) Explain why it was necessary to clean the magnesium ribbon

(1mk)

(b) What observation was made in the crucible after burning

(1 mk)

(c) Why was there an increase in mass?

(1 mk)

(d) Write the equation for the reaction which took place in the crucible

(1mk)

(e) The product in the crucible was shaken with water and filtered. Explain the observation which was made when blue and red litmus papers were dropped into the filtrate. (3mks)

6. (a) The list below shows the formulae of some organic compounds. Use it to answer the questions that follow

V<sub>1</sub> HC<sub>3</sub>CH<sub>2</sub>CH<sub>2</sub>OH

V<sub>2</sub> CH<sub>3</sub>CH<sub>2</sub>CH<sub>3</sub>

V<sub>3</sub>  $\begin{array}{c} \text{O} \\ \parallel \\ \text{CH}_3\text{CH}_2\text{CH}_2\text{C} - \text{OH} \end{array}$

V<sub>4</sub> CH<sub>3</sub>CH<sub>2</sub>CH = CH<sub>2</sub>

V<sub>5</sub> CH<sub>3</sub>CH<sub>2</sub>CH<sub>2</sub>CH<sub>3</sub>

- (i) Select two compounds which  
 I are not hydrocarbons (1mk)  
 II Belong to the same homologous series (1 mk)
- (ii) Identify the compound that is likely to undergo polymerization. Give a reason for your answer. (2mks)

b. The structures below represents two cleansing agents:



In the table below, give one advantage and one disadvantage of using each one of them

	Advantage	Disadvantage
$R - COO^- Na^+$		
$R - OSO_3^- Na^+$		

- a. Under certain, ethanoic acid ( $C_2H_4O_2$ ) and ethanol ( $C_2H_5OH$ ) react to form a sweet smelling compound.
- (i) What is the general name of compound to which the sweet smelling compound belong? (1mk)
- (ii) Write the formula of the sweet smelling compound (1 mk)
- (iii) Give one use of ethanoic acid other the formation of the sweet smelling compounds (1 mk)
- (iv) Write the equation for the reaction dilute ethanoic acid and solid potassium carbonate (1mk)
- b. Fibres are either synthetic or natural. Give one:
- (i) Example of a natural fibre (1mk)
- (ii) Advantage of synthetic fibres have over natural fibres (1mk)

7. (a) Below is a simplified diagram of the Downs Cell used for the manufacture of sodium.

Study it and answer the questions that follow

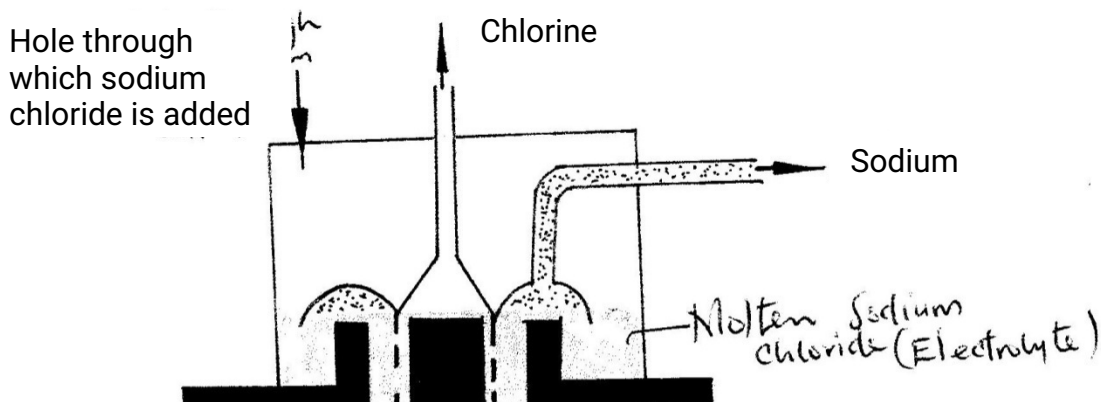

Molten sodium  
chloride(electrolyte)

Circular steel  
cathode

Circular steel  
cathode

Anode

- (i) What material is the anode made of? Give a reason (2mks)
- (ii) What precaution is taken to prevent chlorine and sodium from re- combination?  
(1mks)
- (iii) Write an ionic equation for the reaction in which chlorine gas is formed  
(1mk)
- (b) In the Downs process, (used for manufacture of sodium), a certain salt is added to lower the melting point of sodium chloride from about  $800^{\circ}\text{C}$  to about  $600^{\circ}\text{C}$ .
- (i) Name the salt that is added  
(1mk)
- (ii) State why it is necessary to lower the temperature (1mk)
- (c) Explain why aqueous sodium chloride is not suitable as an electrolyte for the manufacture of sodium in the Downs process  
(2mk)
- (d) Sodium metal reacts with air to form two oxide. Give the formulae of two oxides  
(1mk)



**CHEMISTRY PAPER 233/2**  
**K.C.S.E 2006 QUESTIONS**

1. a) What is an electrolyte? (1mk)
- b) State how the following substances conduct electricity.
- i) Molten calcium chloride (1mk)
  - ii) Graphite. (1mks)
- c) The diagram below shows a set up that was used to electrolyse aqueous magnesium sulphate.

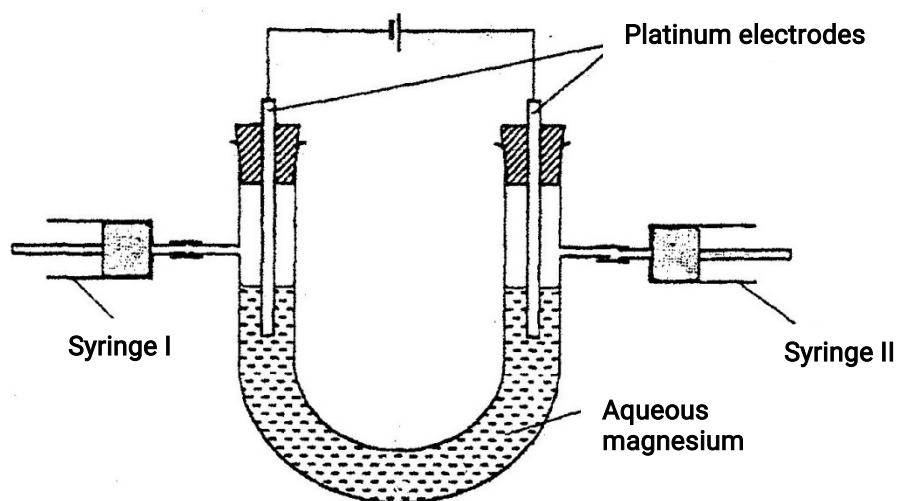

- i) On the diagram above, using an arrow, show the direction of flow of electrons.

(1mk)

ii) Identify the syringe in which hydrogen gas would be collected. Explain

(1mk)

d) Explain why the concentration of magnesium sulphate was found to have increased at the end of the experiment. (2mks)

e) During the electrolysis, a current of 0.72A was passed through the electrolyte for 15 minutes. Calculate the volume of gas produced at the anode. (1 Faraday = 96 500 coulombs; molar gas volume is 24000cm<sup>3</sup> at room temperature).

(4mks)

2. a) In an experiment to determine the molar heat of reaction when magnesium displaces copper, 0.15g of magnesium powder were added to 25.0cm<sup>3</sup> of 2.0M copper (II) chloride solution. The temperature of copper (II) chloride solution was 25°C. While that of the mixture was 43°C.

i) Other than increase in temperature, state and explain the observations which were made during the reaction.

(3mks)

ii) Calculate the heat change during the reaction (specific heat capacity of the solution = 4.2Jg<sup>-1</sup>K<sup>-1</sup> and the density of the solution = 1g/cm<sup>3</sup>) (2mks)

iii) Determine the molar heat of displacement of copper by magnesium. (Mg=24.0).

iv) Write the ionic equation for the reaction. (1mk)

v) Sketch an energy level diagram for the reaction.

(2mks)

b) Use the reduction potentials given below to explain why a solution containing copper ions should not be stored in a container made of zinc.

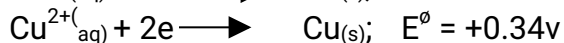

(2mks)

3. a) Distinguish between isotopes and allotropes.

(2mks)

b) The chart below is part of the periodic table. Study it and answer the questions

that follow.(The letters are not the actual symbols of the elements).

A				R		
C	D					F

- i) Select the element in period three which has the shortest atomic radius. Give a reason for your answer.  
(2mks)
  - ii) Element F has the electronic structure, 2.8.18.4 on the chart above, indicate the position of element F.  
(1mks)
  - iii) State one use of the elements of which E is a member.  
(1mk)
  - iv) Write an equation to show the action of heat on the nitrate of element C.  
(1mks)
- c) When 3 litres of chlorine gas were completely reacted with element D, 11.875g of the product were formed. Determine the relative atomic mass of element D. (Atomic mass of chlorine = 35.5; molar gas volume = 24litres).  
(3mks)
4. a) The diagram below shows some processes that take place during the industrial manufacture of sulphuric acid.

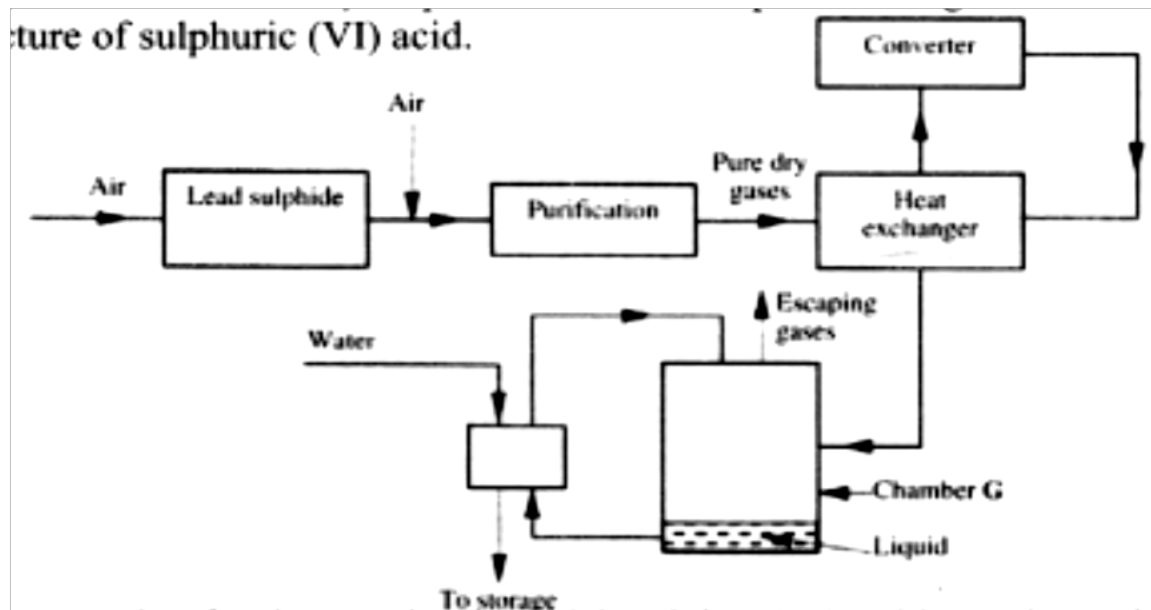

- (i) Write the equation for the reaction in which sulphur dioxide gas is produced. (1mk)
- (ii) Why is it necessary to keep the gases pure and dry? (1mk)
- (iii) Describe the process that takes place in chamber G. (1mk)
- (iv) Name the gases that escape into the environment. (1mk)
- (v) State and explain the harmful effect on the environment of one of the gases named in (iv) above (1mk)
- (vi) Give one reason why it is necessary to use a pressure of 2-3 atmospheres and not more. (1mk)
- b) (i) Complete the table below to show the observations made when concentrated sulphuric acid is added to the substances shown. (2mks)

Substance	Observation
Iron fillings	
Crystals of white sugar	

- (ii) Give reasons for the observations made using:
- I iron fillings (1mk)
- II Crystals of white sugar. (1mk)
- (c) Name one fertilizer made from sulphuric acid. (1mk)
- (d) Suggest a reason why  $\text{BaSO}_4$  (pigment made from sulphuric acid) would be suitable in making paint for cars. (1mk)
5. a) What name is given to a compound that contains carbon and hydrogen only? (½mk)
- b) Hexane is a compound containing carbon and hydrogen.
- (i) What method is used to obtain hexane from crude oil? (1mk)
- (ii) State one use of hexane (1mk)
- c) Study the flow chart below and answer the questions that follow.

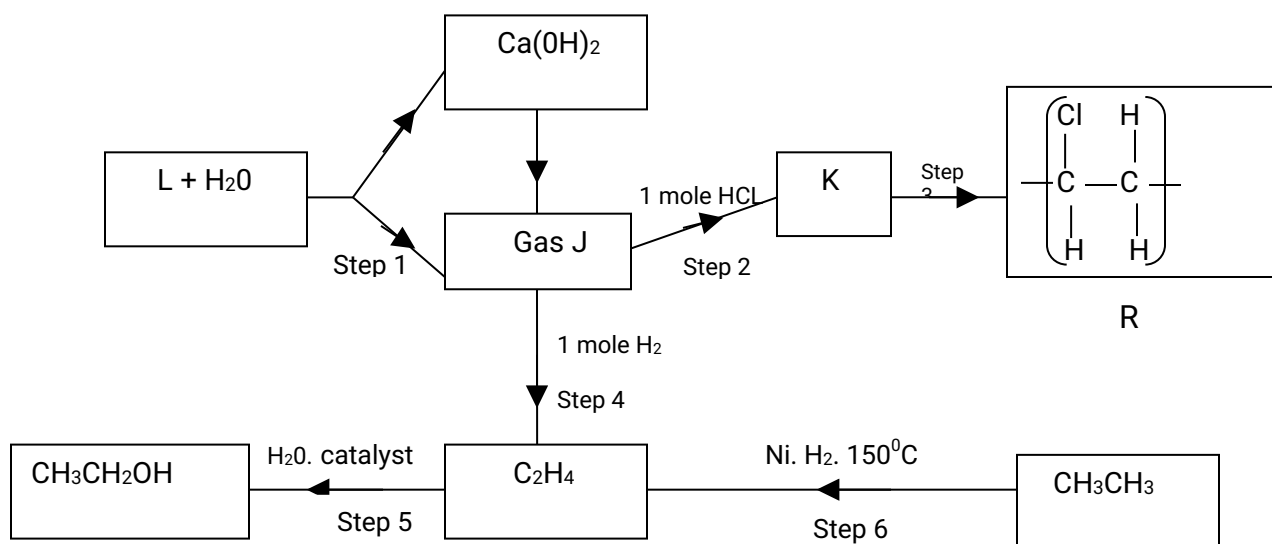

- (i) Identify reagent L. (1mk)
- (ii) Name the catalyst used in step 5. (1mk)
- (iii) Draw the structural formula of gas J. (1mk)
- (iv) What name is given to the process that takes place in step 5? (½mk)

- d) (i) write the equation for the reaction between aqueous sodium hydroxide and aqueous ethanoic acid. (1mk)
- (ii) Explain why the reaction between 1g of sodium carbonate and 2M hydrochloric acid is faster than the reaction between 1g of sodium carbonate and 2M ethanoic acid. (1mks)

6. The extraction of iron from its ores takes place in the blast furnace. Study it and answer the questions that follow.

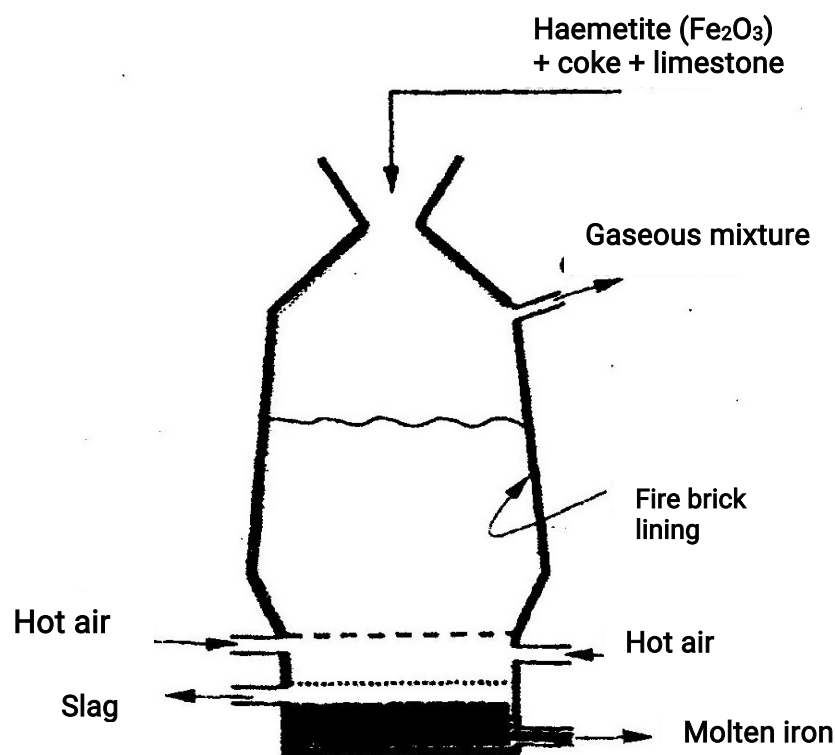

- a) Name
- One of the substances in the slag (1mk)
  - Another iron ore material used in the blast furnace. (1mk)
  - One gas which is recycled. (1mk)
- b) Describe the process which lead to the formation of iron in the blast furnace
- c) State the purpose of limestone in the blast furnace. (3mks)
- d) Give a reason why the melting point of the iron obtained from the blast furnace is  $1200^{\circ}\text{C}$  while tat of pure iron is  $1535^{\circ}\text{C}$  (1mk)
- e) State two uses of steel (2mks)

7. The table below shows the volumes of nitrogen dioxide gas produced when different volume of 1M nitric acid were each reacted with 2.07 g of lead at room temperature.

Volume of 1 M nitric acid (cm <sup>3</sup> )	Volume of nitrogen dioxide gas (cm <sup>3</sup> )
5	60
15	180
25	300
35	420
45	480
55	480

- a) Give a reason why nitric acid is not used to prepare hydrogen gas. (1mk)
- b) Explain how the rate of the reaction between lead and nitric acid would be affected if the temperature of the reaction mixture was raised. (2mks)
- c) On the grid provided below, plot a graph of the volume of the gas produced (Vertical axis) against volume of acid. (3mks)
- d) Using the graph, determine the volume of:
- i) Nitrogen dioxide produced when 30cm<sup>3</sup> of 1 M nitric acid were reacted with 2.07 g of lead (1mk)
- ii) 1M nitric acid which would react completely with 2.07g of lead. (1mk)
- e) Using the answer in d(i) above, determine:
- i) The volume of 1M nitric acid that would react completely with one mole of lead (pb=207) (2mks)
- ii) The volume of nitrogen dioxide gas produced when one mole of lead reacts with excess 1 M nitric room temperature. (1mk)



- f) Calculate the number of moles of:
- 1M nitric acid that reacted with one mole of lead  
(1mk)
  - nitrogen dioxide produced when one mole of lead were reacted with excess nitric acid. (Molar gas volume of  $2400\text{cm}^3$ )  
(1mk)
- g) Using the answers obtained in f (i) and (ii) above, write the equation for the reaction between lead and nitric acid given that one mole of lead nitrate and two moles of water were also produced.  
(1mk)

## CHEMISTRY PAPER 233/2

### K.C.S.E 2007 QUESTIONS

1. (a) State two factors that should be considered when choosing fuel for cooking  
(2mks)

- (b) The diagram below represents a set – up that was used to determine the molar heat of combustion of ethanol

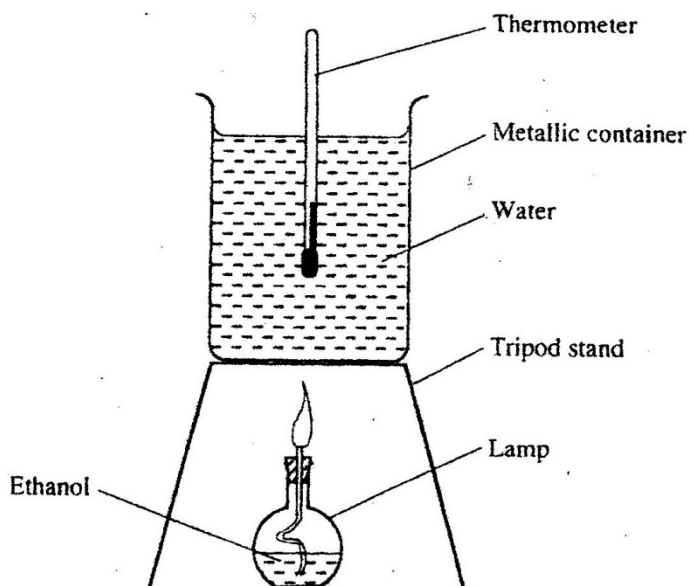

During the experiment, the data given below was recorded

Volume of water	$450\text{cm}^3$
Initial temperature of water	$25^\circ\text{C}$
Final temperature of water	$46.5^\circ\text{C}$

Mass of ethanol + Lamp before burning 125.5g  
Mass of ethanol + lamp after burning 124.0g

Calculate the:

(i) Heat evolved during the experiment (density of water =  $1\text{g/cm}^3$   
Specific heat capacity of water =  $4.2\text{ Jg}^{-1}\text{K}^{-1}$

(3mks)

(ii) Molar heat of combustion of ethanol (C = 12.0, O = 16.0, H=1.0)

(2mks)

(c) Write the equation for the complete combustion of ethanol

(1mk)

(d) The value of the molar heat of combustion of ethanol obtained in (b) (ii) above is lower than the theoretical value. State two sources of error in the experiment.

(2mks)

2. (a) Give the systematic names of the following compounds

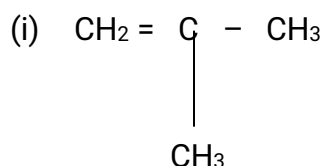

(1 mk)

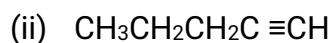

(1mk)

(b) State the observations made when Propan – I- ol reacts with:

(i) Acidified potassium dichromate (VI) Solution

(1mk)

(ii) Sodium metal

(1mk)

(c) Ethanol obtained from glucose can be converted to ethane as shown below

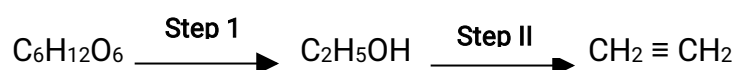

Name and describe the process that take place in steps I and II

Step I

(1½ mks)

Step II

(1½ mks)

- (d) Compounds A and B have the same molecular formula  $C_3H_6O_2$ . Compound A liberates carbon (IV) oxide on addition of aqueous sodium carbonate while compound B does not. Compound B has a sweet smell. Draw the possible structures of:
- (i) Compound A (1 mk)
- (ii) Compound B (1 mk)
- (e) Give two reasons why the disposal of polymers such as polychloroethane by burning pollutes the environment. (2mks)

3. The flow chart below shows a sequence of chemical reactions starting with copper study it and answer the questions that follow.

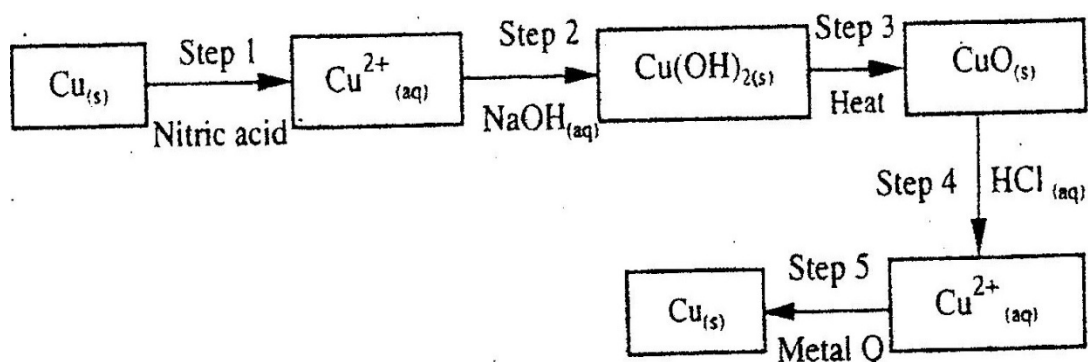

- (a) In step 1, excess 3M nitric acid was added to 0.5g of copper powder
- (i) State two observations which were made when the reactions was in progress (2mks)
- (ii) Explain why dilute hydrochloric acid cannot be used in step 1 (1mk)
- (iii) I Write the equation for the reaction that took place in step 1 (1mk)
- II Calculate the volume of 3M nitric that was needed to react completely

with 0.5g of copper powder. (Cu = 63.5)

(3 mk)

- (b) Give the names of the types of reactions that took place in steps 4 and 5  
(1 mk)

Step 4

Step 5

- (c) Apart from the good conductivity of electricity, state two other properties that make it possible for copper to be extensively used in the electrical industry.  
(2mks)

4. (a) Methanol is manufactured from carbon (IV) oxide and hydrogen gas according to the equation:

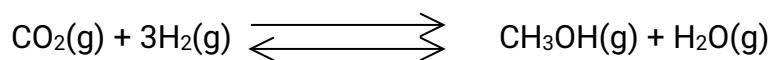

The reaction is carried out in the presence of a chromium catalyst at 700K and 30kPa. Under these conditions, equilibrium is reached when 2% of the carbon (IV) oxide is converted to methanol

- (i) How does the rate of the forward reaction compare with that of the reverse reaction when 2% of the carbon (IV) oxide is converted to methanol?  
(1 mk)

- (ii) Explain how each of the following would affect the yield of methanol:

I Reduction

(2mks)

II Using a more efficient catalyst

(2mks)

- (iii) If the reaction is carried out at 500K and 30kPa, the percentage of carbon (IV) oxide converted to methanol is higher than 2%

I what is the sign of  $\Delta H$  for the reaction? Give a reason

(2mks)

II Explain why in practice the reaction is carried out at 700K but NOT at 500K

(1mk)

- (b) Hydrogen peroxide decomposes according to the following equation:

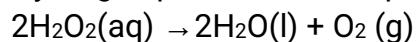

In an experiment, the rate of decomposition of hydrogen peroxide was found to be  $6.0 \times 10^{-8} \text{ mol dm}^{-3} \text{ s}^{-1}$ .

(i) Calculate the number of moles per  $\text{dm}^3$  of hydrogen peroxide that had decomposed within the first 2 minutes (2mks)

(ii) In another experiment, the rate of decomposition was found to be  $1.8 \times 10^{-7} \text{ mol dm}^{-3} \text{ s}^{-1}$ . The difference in two rates could have been caused by addition of a catalyst. State, giving reasons, one other factor that may have caused the difference in two rates of decomposition (2mks)

5. (a) The diagram below represents part of the structure of a sodium chloride crystal. The position of one of the sodium ions in the crystal is shown as  $\oplus$

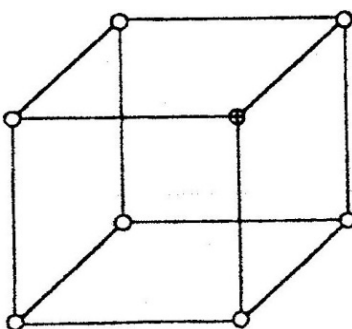

(i) On the diagram, mark the position of the other three sodium ions (2mks)

(ii) The melting and boiling points of sodium chloride are  $801^\circ\text{C}$  and  $1413^\circ\text{C}$  respectively.

Explain why sodium chloride does not conduct electricity at  $25^\circ\text{C}$ , but does so at temperatures between  $801^\circ\text{C}$  and  $1413^\circ\text{C}$

(2mks)

(b) Give a reason why ammonia gas is highly soluble in water (2mks)

(c) The structure of an ammonia ion is shown below:

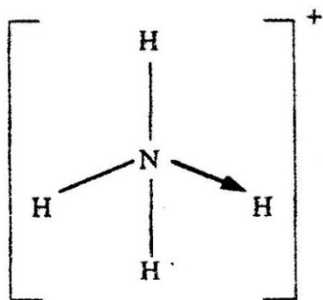

Name the type of bond represented in the diagram by N → H (1 mk)

(d) Carbon exists in different crystalline forms. Some of these forms were recently discovered in soot and are called fullerenes

(i) What name is given to different crystalline forms of the same element? (1mk)

(ii) Fullerenes dissolve in methylbenzene while the other forms of carbon do not.

Given that soot is a mixture of fullerenes and other solid forms of carbon, describe how crystals of fullerenes can be obtained from soot.

(3mks)

(iii) The relative molecular mass of one of the fullerenes is 720. What is the molecular formula of this fullerene? (C=12.00)  
(1 mk)

6. (a) The elements nitrogen, phosphorous and potassium are essential for plant growth.

(i) Potassium in fertilizers may be in the form of potassium nitrate. Describe how a sample of a fertilizer may be tested to find out if it contained nitrate ions.

(2mks)

(ii) Calculate the mass of nitrogen present if a 25kg bag contained pure ammonium phosphate,  $(\text{NH}_4)_2\text{HPO}_4$ .

(N = 14.0, H=1.0, P = 31.0, O = 16.0)

(2mks)

(b) The table below shows the solubility of ammonium phosphate in water at different temperatures.

Temperature (C <sup>0</sup> )	Solubility of ammonium phosphate in g/100g water
10	63.0
20	69.0
30	75.0

40	82.0
50	89.0
60	97.0

(i) On the grid provided, draw the solubility curve of ammonium phosphate  
(Temperature on x – axis)  
(3mks)

(ii) Using the graph, determine the solubility of ammonium phosphate at 25°C  
(1 mk)

(iii) 100g of a saturated solution of ammonium phosphate was prepared at 25°C

I what is meant by a saturated solution? (1mk)

II Calculate the mass of ammonium phosphate which was used to prepare the saturated solution  
(2mks)

(c) The graph below shows how the PH value of soil in a farm changed over a period of time

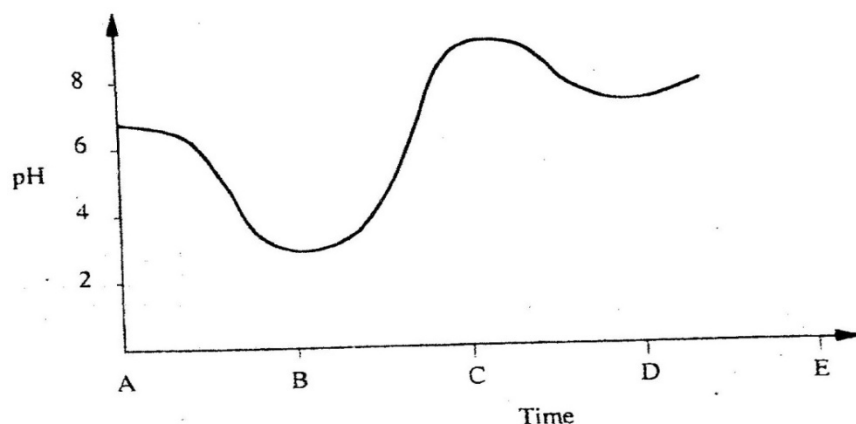

(i) Describe how the pH of the soil can be determined  
(2mks)

(ii) State one factor that may have been responsible for the change in the soil pH in the time interval AB (1 mk)

7. The diagram below shows the set up used in an experiment to prepare chlorine gas and react it with aluminium foil. Study it and answer the question that follow

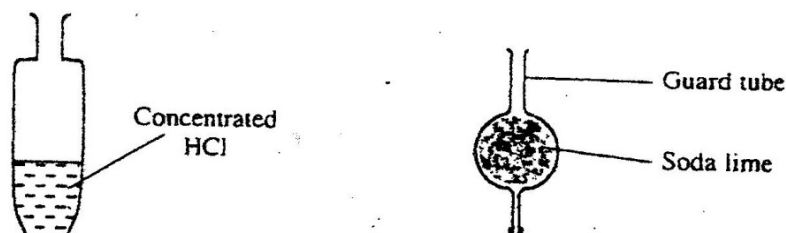

- (a) In the experiment, concentrated hydrochloric acid and potassium manganate (VII) were used to prepare chlorine gas. State two precautions that should be taken in carrying out this experiment. (2mks)
- (b) Write the formula of another compound that could be used instead of potassium manganate (VII)  
(1 mk)
- (c) Explain why it is necessary to allow the acid to drip slowly onto potassium manganate (VII) before the aluminium foil is heated. (2mks)
- (d) State the property of the product formed in the combustion tube that makes it possible for it to be collected in the receiver (1mk)
- (e) When 1.08g of aluminum foil were heated in a stream of chlorine gas, the mass of the product formed was 3.47 g  
Calculate the:
- (i) Maximum mass of the product formed if chlorine was in excess;  
(Al= 27; Cl = 35.5)
- (ii) Percentage yield of the product formed (1 mk)
- (f) Phosphorous trichloride is a liquid at room temperature. What modification should be made to set up if it is to be used to prepare phosphorous trichloride?  
(1 mk)

## CHEMISTRY PAPER 233/2



## K.C.S.E 2008 QUESTIONS

1. a) Biogas is a mixture of mainly carbon (IV) oxide and methane.
- (i) Give a reason why biogas can be used as a fuel.  
(1mk)
- (ii) Other than fractional distillation, describe a method that can be used to determine the percentage of methane in biogas.  
(3mks)
- b) A sample of biogas contains 35.2% by mass of methane. A biogas cylinder contains 5.0 kg of the gas.  
Calculate the;
- (i) Number of moles of methane in the cylinder. (Molar mass of methane=16)  
(2mks)
- (ii) Total volume of carbon (IV) oxide produced by the combustion of methane in the cylinder (Molar gas Volume=24.0 dm<sup>-3+</sup> at room temperature and pressure).  
(2mks)
- c) Carbon (Iv) oxide, methane, nitrogen (I) oxide and trichlorofluoromethane are green-house gases.
- (i) State one effect of an increased level of these gases to the environment.  
(1mk)
- (ii) Give one source from which each of the following gases is released to the environment;
- I Nitrogen (i) oxide (1 mk)
- II Trichlorofluoromethane. (1mk)
2. a) Write an equation to show the effect of heat on the nitrate of:
- (i) Potassium (1mk)
- b) The table below gives information about elements A<sub>1</sub>A<sub>2</sub>A<sub>3</sub>, and A<sub>4</sub>

Element	Atomic Number	Atomic Radius (nm)	Ionic radius (nm)
A <sub>1</sub>	3	0.134	0.074
A <sub>2</sub>	5	0.090	0.012
A <sub>3</sub>	13	0.143	0.050
A <sub>4</sub>	17	0.099	0.181

(i) In which period of the periodic table is element  $A_2$ ? Give a reason (2mks)

(ii) Explain why the atomic radius of:

I  $A_1$  is greater than that of  $A_2$ ;

II  $A_4$  is smaller than its ionic radius

(2mks)

(iii) Select the element which is in the same group as  $A_3$

(1 mk)

(iv) Using dots (.) and crosses(x) to represent outermost electrons. Draw a diagram to show the bonding in the compound formed when  $A_1$  reacts with  $A_4$

(1 mk)

3. (a) Describe the process by which Nitrogen is obtained from air on a large scale.

(4mks)

(b) Study the flow chart below and answer the questions that follow.

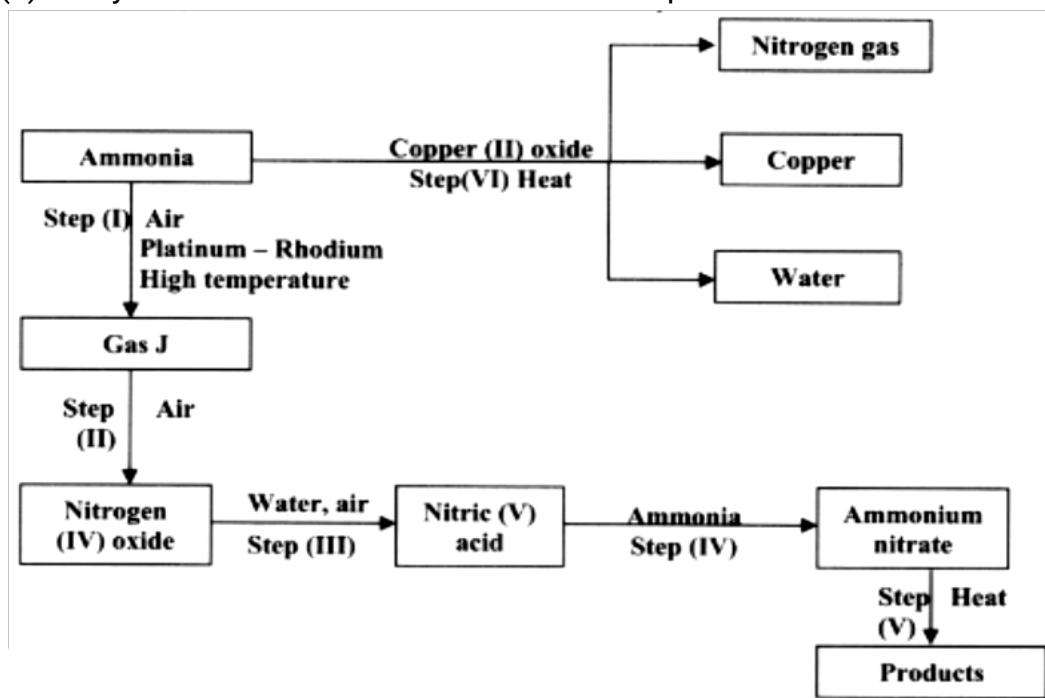

(i) Identify gas J.

(1 mk)

(ii) Using oxidation numbers, show that ammonia is the reducing agent

in step (VI)

(2mks)

(iii) Write the equation for the reaction that occurs in step (V).  
(1mk)

(iv) Give one use of ammonium nitrate.  
(1mk)

c) The table below shows the observations made when aqueous ammonia was added to cations of elements F<sub>2</sub>F and G until in excess.

Cation of	Addition of a few drops of Aqueous ammonia.	Addition of excess aqueous ammonia.
E	White precipitate	Insoluble
F	No precipitate	No precipitate
G	White precipitate	Dissolves

(i) Select the cation that is likely to be Zn<sup>2+</sup> (1mk)

(ii) Given that the formula of the cation of element E is E<sup>2+</sup>, write the ionic equation for the reaction between E<sup>2+</sup><sub>(aq)</sub> and aqueous ammonia.  
(1mk)

4.a) (i) State the Le chatelier's principle. (1mk)

(ii) Carbon (II) oxide gas reacts with steam according to the equation;  
 $\text{CO}_{(g)} + \text{H}_2\text{O}_{(g)} \longrightarrow \text{H}_2_{(g)} + \text{CO}_{(g)} + 2\text{H}_2_{(g)}$

What would be the effect of increasing the pressure of the system at equilibrium? Explain.  
(2mks)

b) The table below gives the volumes of oxygen gas produced at different times when hydrogen peroxide decomposed in the presence of a catalyst.

Time(Sec)	0	10	20	30	40	50	60
Volume of oxygen (cm <sup>3</sup> )	0	66	98	110	119	120	120

- (i) Name the catalyst used for this reaction (1mk)
- (ii) On the grid provided, draw the graph of volume of oxygen gas produced (vertical axis) against time. (3mks)
- (iii) Using the graph, determine the rate of decomposition of hydrogen peroxide after 24 seconds. (2mks)
- (iv) Give a reason why the total volume of oxygen gas produced after 50 seconds remains constant. (1mk)
5. (a) Alkanes, alkenes and alkynes can be obtained from crude oil. Draw the structure of the second member of the alkyne homologous series. (1mk)
- (b) Study the flow chart below and answer the questions that follow

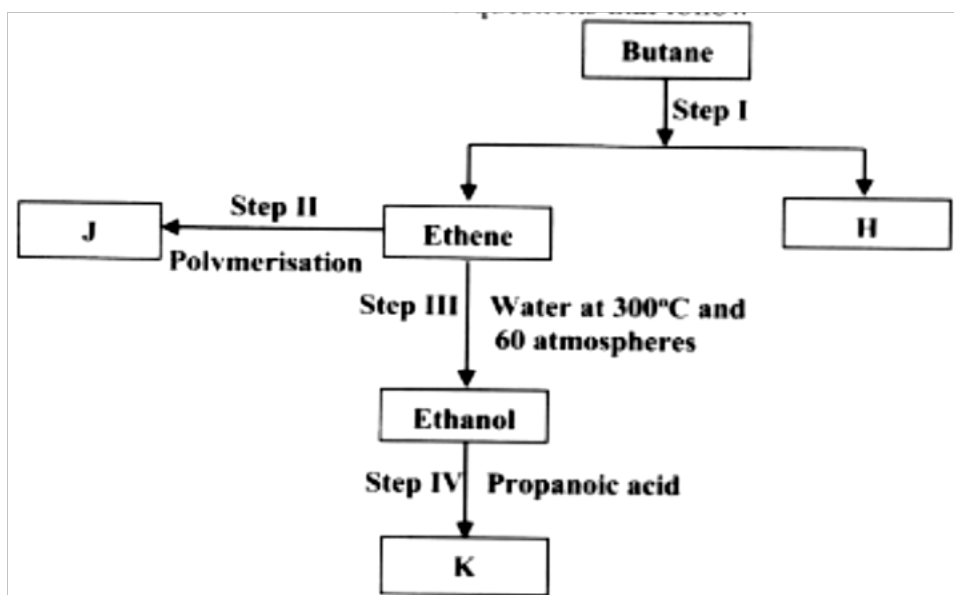

- (i) State the conditions for the reaction in step 1 to occur (1 mk)
- (ii) Identify substance H (1 mk)
- (iii) Give:
- I. One advantage of the continued use of substance such as J (1 mk)
  - II The name of the process that takes place in step III (1 mk)
  - III The name and the formula of substance K (2mks)

Name:.....

Formula:.....

(iv) The relative molecular mass of J is 16,800. Calculate the number of monomers that make up J.

(c) The table below give the formula of four compounds L,M,N and P

Compound	Formula
L	$C_2H_6O$
M	$C_3H_6$
N	$C_3H_6O_2$
P	$C_3H_8$

Giving a reason in each case, select the letter which represents a compound that:

(i) Decolorizes bromine in the absence of UV light (2mks)

(ii) Gives effervescence when reacted with aqueous sodium carbonate (2mks)

6. The diagram below represents a set up that can be used to electrolyze aqueous copper (II) sulphate.

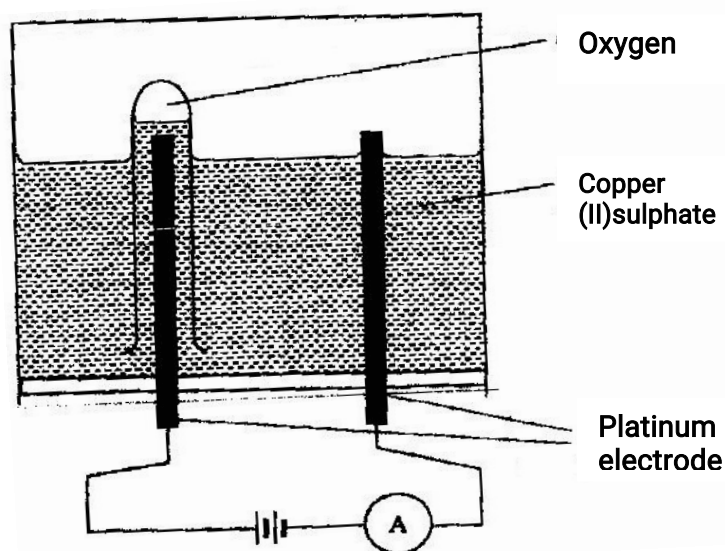

(a)(i) Describe how oxygen gas is produced during the electrolysis (2mks)

(ii) Explain why copper electrodes are not suitable for this electrolysis (2mks)

(b) Impure copper is purified by an electrolytic process

- (i) Name one ore from which copper is obtained (1mk)
- (ii) Write the equation for the reaction that occur at the cathode during the purification of copper (1mk)
- (iii) In an experiment to electroplate a copper spoon with silver, a current of 0.5 A was passed for 18 minutes. Calculate the amount of silver deposited on the spoon ( $\pi = 96500$  coulombs,  $Ag = 108$ ) (3mks)
- (iv) Give two reasons why some metals are electroplated (2mks)

7. (a) Define the standard enthalpy of formation of a substance (1mk)

(b) Use the thermo chemical equations below to answer the questions that follow.

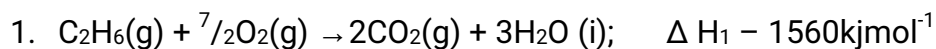

- (i) Name two types of heat changes represented by  $\Delta H_3$  (2mks)
- (ii) Draw an energy level diagram for the reaction represented by equation 1
- (iii) Calculate the standard enthalpy of formation of ethane (2mks)
- (iv) When a sample of ethane was burnt, the heat produced raised the temperature of 500g of water by 21.5 K, (specific heat capacity of water =  $4.2 \text{ J g}^{-1} \text{ K}$ ). Calculate the:
- I. Heat change for the reaction (2mks)
  - II. Mass of ethane was burnt. (relative formula mass of ethane = 30) (2mks)



**CHEMISTRY PAPER 233/2**  
**K.C.S.E 2009 QUESTIONS**

1. a) Two reagents that can be used to prepare chlorine gas are manganese (IV) oxide and concentrated hydrochloric acid.

i) Write an equation for the reaction.

(1 mk)

ii) Give the formula of another reagent that can be reacted with concentrated hydrochloric acid to produce chlorine gas.

(1 mk)

iii) Describe how the chlorine gas could be dried in the laboratory

(2mks)

b) In an experiment, dry chlorine gas was reacted with aluminium as shown in figure 1.

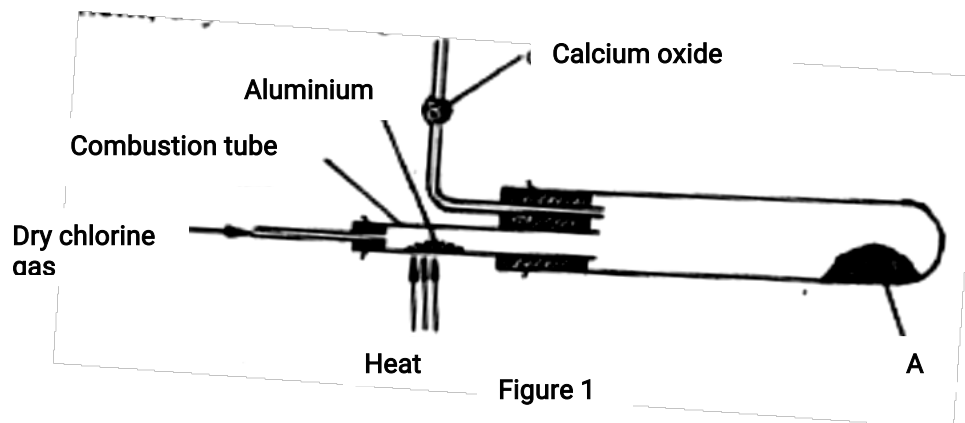

i) Name substance A.

(1 mk)

ii) Write an equation for the reaction that took place in the combustion tube.

(1mk)

iii) 0.84 g of aluminium reacted completely with chlorine gas. Calculate the volume of chlorine gas used (Molar gas volume is  $24\text{dm}^3$ ,  $A_r = 27$ ).

(3mks)

iv) Give two reasons why calcium oxide is used in the set up.

(2mks)

2 a) Draw the structures of the following compounds:

(2mks)

i) 2- methylbut -2 ene;



- ii) heptanoic acid
- b) Describe a physical test that can be used to distinguish between methanol and hexanol. (2mks)
- c) Use the flow chart below to answer the questions that follow.

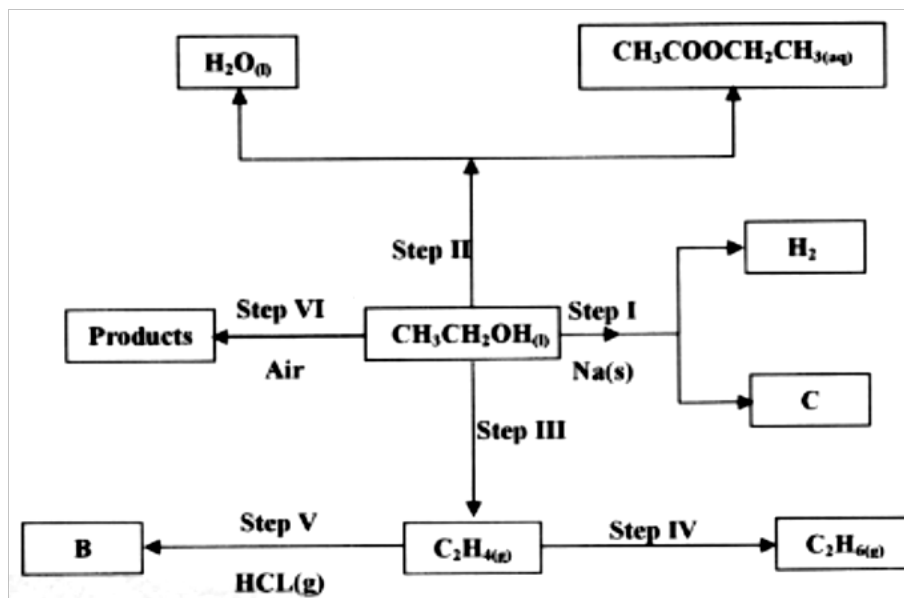

- i) Name:  
 (I) the type of reaction that occurs in step II;  
 (1 mk)  
 (II) Substance B. (1 mk)
- ii) Give the formula of substance C. (1 mk)
- iii) Give the reagent and the conditions necessary for the reaction in step (IV)  
 (3mks)
- 3 The set-up below (figure 2) was used to electrolyse a bromide of metal D  $D\text{Br}_2$ .

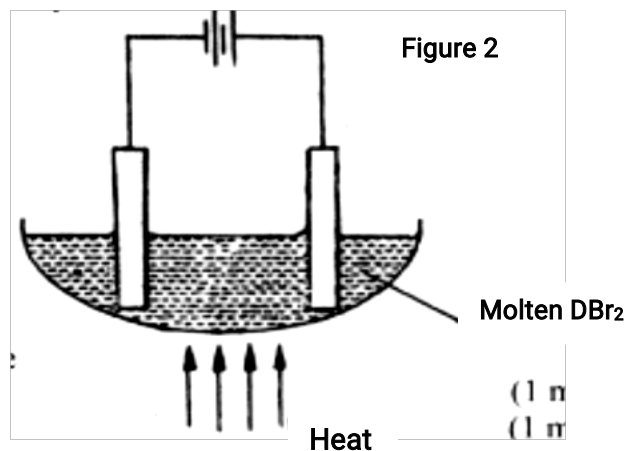

- i) Write equation for the reactions at the  
 I cathode (1 mk)  
 II anode (1mk)
- ii) The electrodes used in the experiment were made of carbon and metal D. which of the two electrodes was used as the anode? Give a reason.  
 (2 mks)
- iii) Give a reason why this experiment is carried out in a fume cupboard.  
 (1 mk)
- iv) When a current of 0.4 A was passed for 90 minutes, 2.31 g of metal D were deposited.
- I Describe how the amount of metal D deposited was determined.  
 (3mks)
- II Calculate the relative atomic mass of metal D. (1 Faraday = 96500 coulombs)  
 (3 mks)
4. a) the schematic diagram shows part of the Solvay process used for the manufacture of sodium carbonate.

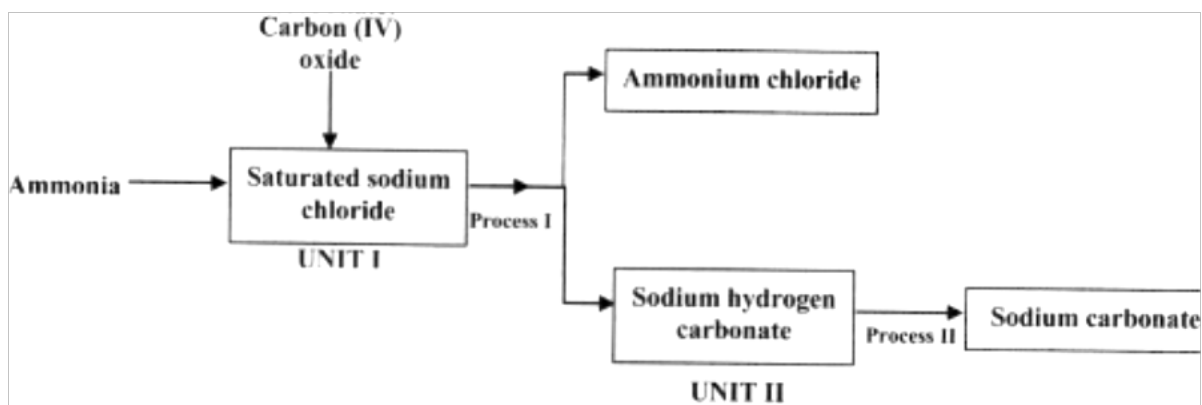

- i) Explain how the sodium chloride required for this process is obtained from sea water. (2mks)
- ii) Two main reactions take place in UNIT I . The first one is the formation of ammonium hydrogen carbonate.
- I. Write an equation for this reaction (1 mk)
  - II. Write an equation for the second reaction (1 mk)
- iii) State how the following are carried out: (2mks)
- I Process I
  - II) Process II
- iv) In an experiment to determine the percentage purity of the sample of sodium carbonate produced in the Solvay process, 2.15 g of the sample reacted completely with 40.0cm<sup>3</sup> of 0.5 M sulphuric acid.
- I calculate the number of moles of sodium carbonate that reacted. (2mks)
  - II Determine the percentage of sodium carbonate in the sample. (Na= 23.0, C= 12.0, O = 16.0) (2mks)
- b) Name two industrial uses of sodium carbonate have been identified and others labelled. (2mks)

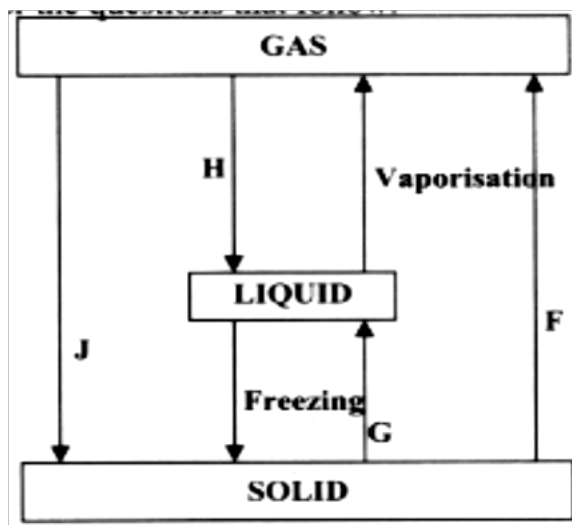

- i) Give the names of the processes
- |    |   |        |
|----|---|--------|
| I  | H | (1 mk) |
| II | G | (1 mk) |
- ii) Name one substance that can undergo process F when left in an open container in the laboratory. (1 mk)
- iii) The process J is called deposition. Using water as an example, write an equation that represents the process of deposition. (1 mk)

b) Figure 4 shows the heating curve for water.

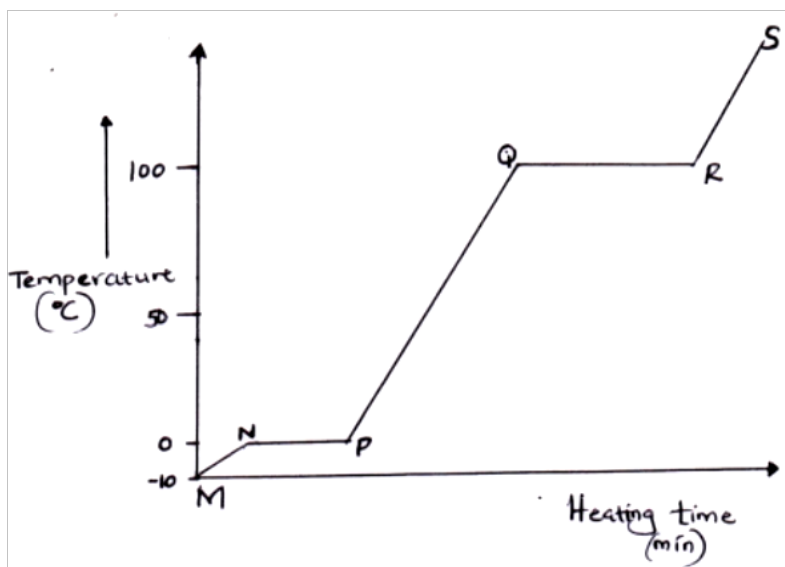

i) Give the names of the intermolecular forces of attraction in the segments;

- |    |    |        |
|----|----|--------|
| I  | MN | (1mk)  |
| II | RS | (1 mk) |

ii) The heats of fusion and vaporization of water are  $334.4 \text{ Jg}^{-1}$  and  $1159.4 \text{ Jg}^{-1}$  respectively.

- |    |  |        |
|----|--|--------|
| I  | Explain why there is a big difference between the two. | (2mks) |
| II | How is the difference reflected in the curve?          |        |

(1 mk)

c) Coal, oil and natural gas are major sources of energy. They are known as fossil fuels. Hydrogen is also a source of energy.

i) State and explain two reasons why hydrogen is a very attractive fuel compared to fossils.

(3mks)

ii) State one disadvantage of using hydrogen fuel instead of fossil fuels.

6. a) Study the table below and complete it. ( $W^{-1}$  and  $X^{4+}$  are not the actual symbols of the ions).

(2mks)

Iron	Number of protons	Number of neutrons	Mass Number	Electron arrangement
W	.....	20	.....	2.8.8
X <sup>4+</sup>	14	.....	28	.....

b) State the observation that would be made in the following tests to distinguish between:

i) Sodium and copper burning pieces of each in air.  
(2 mks)

ii) Sodium and Magnesium by placing small pieces of each in cold water which contains two drops of phenolphalein.  
(2mks)

c) The atomic numbers of Na and Mg are 11 and 12 respectively. Which of the elements has a higher ionization energy? Explain.  
(2mks)

d) Naturally occurring uranium consists of three isotopes which are radioactive.

Isotope	234	235	238
	U	U	U
Abundance	0.01%	0.72%	99.27%

i) Which of these isotopes has the longest half-life? Give a reason

(1 mk)

ii) Calculate the relative atomic mass of uranium  
(2mks)

iii)  ${}_{92}^{235}\text{U}$  is alpha emitter. If the product of the decay of this  ${}_{92}^{235}\text{U}$  nuclide is thorium (Th) . Write a nuclear equation for the process.

(1mk)

7. Iron is obtained from haematite using a blast furnace shown in figure 5 below.

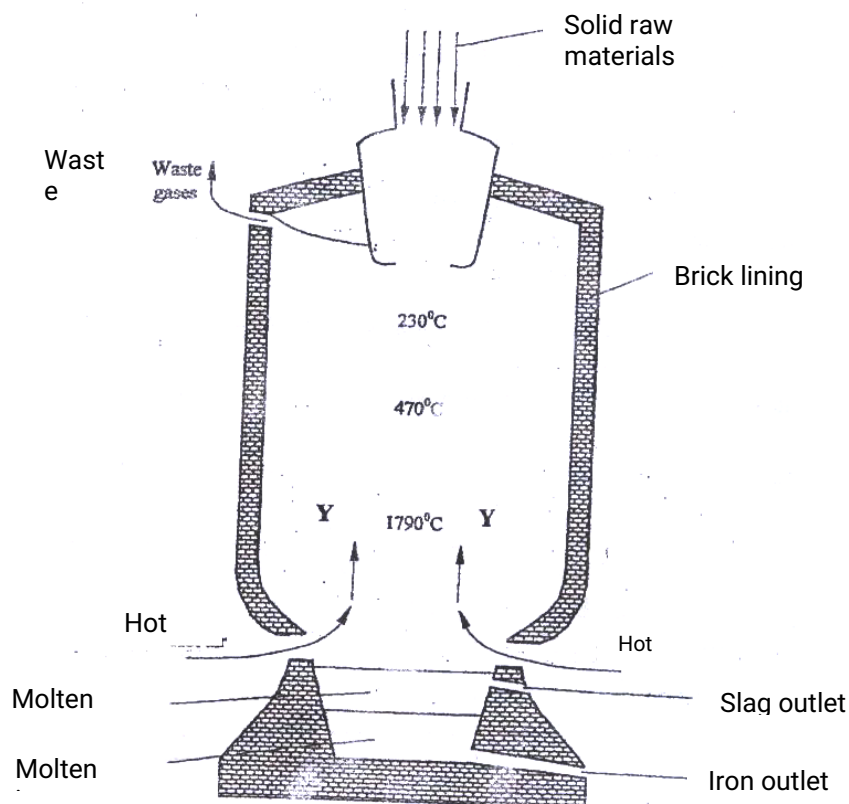

- a) Four raw materials are required for the production of iron. Three of these are iron oxide, hot air and limestone  
Give the name of the fourth raw material (1 mk)
- b) Write an equation for the reaction in which carbon (IV) oxide is converted into carbon (II) oxide.  
(1mk)
- c) Explain why the temperature in the region mked Y is higher than that of the incoming hot air. (2 mks)
- d) State one physical property of molten slag other than density that allows it to be separated from molten iron as shown in figure 5.  
(1mk)
- e) One of the components of the waste gases is Nitrogen (IV) oxide describe the adverse effects it has on the environment.  
(2mks)

- f) Iron from the blast furnace contains about 5% carbon  
 i) Describe how the carbon content is reduced.  
 (2mks)
- ii) Why is it necessary to reduce the carbon content?  
 (1 mk)

## CHEMISTRY PAPER 233/2 K.C.S.E 2010 QUESTIONS

- 1.
- a) Which one of the following compounds; urea, ammonia, sugar and copper (II) chloride will conduct an electric current when dissolved in water? Give reasons.  
 (2mks)
- b) The diagram below shows an electrochemical cell. Study it and answer the questions that follows.

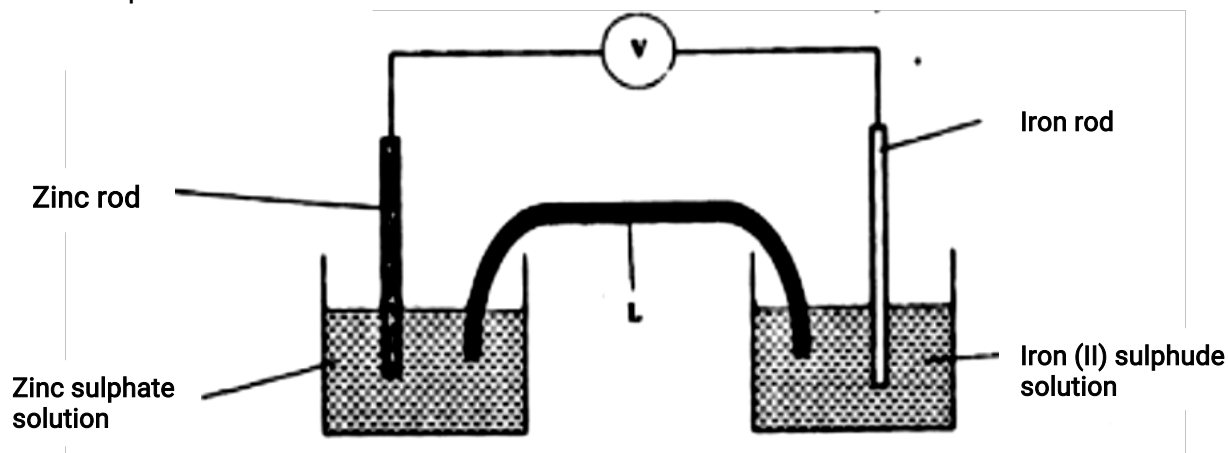

Given the following

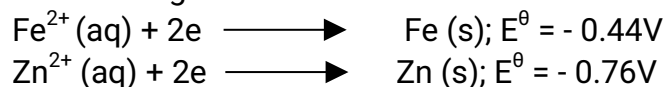

- i) Show on the diagram using an arrow, the direction of flow of electrons (1 mk)
- ii) Name **two** substances that are used to fill the part labeled L  
 (2 mks)
- c) In an experiment to electroplate iron with silver, a current of 0.5 amperes was passed through a solution of silver nitrate for an hour



- i) Give **two** reasons why it is necessary to electroplate iron with silver (2mks)
- ii) Calculate the mass of silver that was deposited on iron (Ag = 108, 1 Faraday = 96,500 coulombs) (3mks)

2.

- i. Give the name of the following compounds:



- ii. Describe a chemical test that can be carried out in order to distinguish between

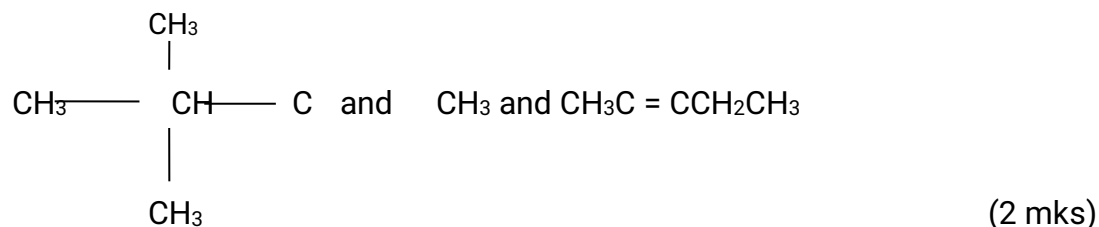

- iii. Study the flow chart below and answer the questions that follows

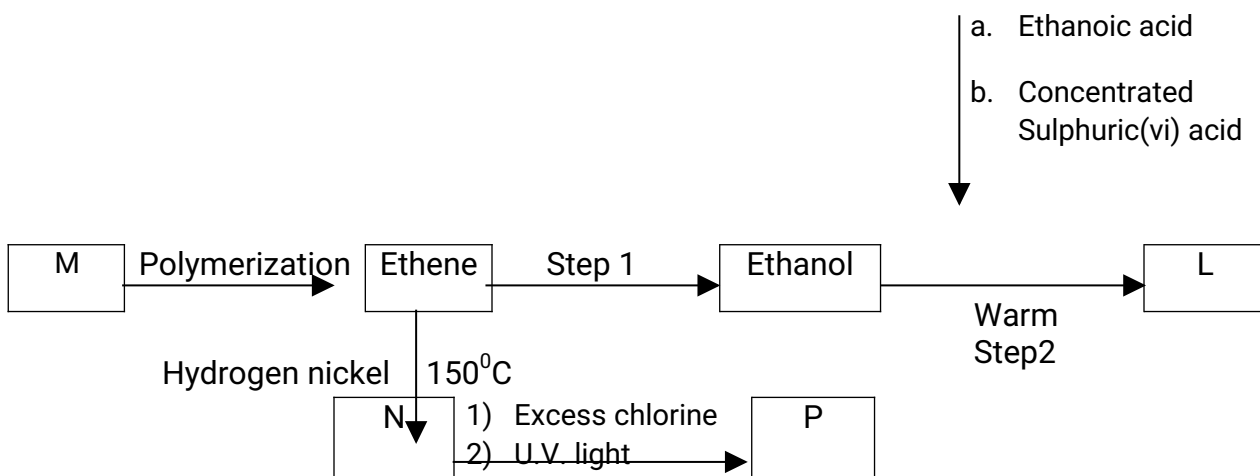

### Step 3

- i) Name the compounds: (2mks)
2. L
  3. N

ii) Draw the structural formula of compound M showing two repeat units (1 mk)

iii) Give the reagent and the conditions used in step I (1 mk)

- iv) State the type of reaction that take place in: (2mks)
- a. Step 2
  - b. Step 3

2. The molecular formula of compound P is  $C_2H_2Cl_4$ . Draw the two structural formulae of compound P (2mks)

3. Use the information in the table below to answer the questions that follow. The letters do not represent the actual symbols of the elements.

Element	Atomic number	Melting point ( $^{\circ}C$ )

R	11	97.8
S	12	650.0
T	15	44.0
U	17	-102
V	18	-189
W	19	64.0

a) Give the reasons why the melting point of:

i) S is higher than that of R

(1 mk)

ii) V is lower than that of U

(2mks)

b) How does the reactivity of W with chlorine compare with that of R with chlorine?

Explain,

(2 mks)

c) Write an equation for the reaction between T and excess oxygen

(1 mk)

d) When 1.15g of R were reacted with water,  $600\text{cm}^3$  of gass was produced.

Determine the relative atomic mass of R. (Molar gas volume =  $24000\text{cm}^3$ )

(3mks)

e) Give one use of element V

(1 mk)

4.

a.  $50\text{cm}^3$  of 1M copper (II)sulphate solution was placed in a  $100\text{cm}^3$  plastic beaker. The temperature of the solution was measured. Excess metal A powder was added to the solution, the mixture stirred and the maximum temperature was repeated using

powder of metals **B** and **C**. The results obtained are given in the table below:

	<b>A</b>	<b>B</b>	<b>C</b>
Maximum temperature (°C)	26.3	31.7	22.0
Initial temperature (°C)	22.0	22.0	22.0

1. Arrange the metal **A**, **B**, **C** and copper in order of reactivity starting with the least reactive. Give reasons for the order.  
(3mks)
  2. Other than temperature change, state one other observation that was made when the most reactive metal was added to the copper(II) sulphate solution.  
(1 mk)
- b. The standard enthalpy change of formation of methanol is  $-239 \text{ kJmol}^{-1}$ .
- i) Write the thermochemical equation for the standard enthalpy change of formation of methanol. (1 mk)
  - ii) Methanol is manufactured by reacting carbon(II)oxide with hydrogen at  $300^{\circ}\text{C}$  and a pressure of 250 atmospheres.  
The equation for the reaction is:

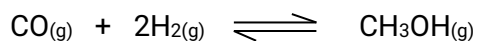

1. How would the yield of methanol be affected if the manufacturing process above is carried out at 300°C and a pressure of 400 atmosphere? Explain (2mks)
2. Use the following data to calculate the enthalpy change for the manufacture of methanol from carbon(II)oxide and hydrogen (3mks)

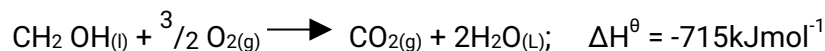
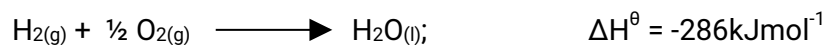
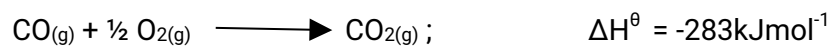

- iii) The calculate enthalpy change in part B(ii) (II) above differ from the standard enthalpy change of formation of methanol. Give a reason. (1 mk)

5.

- a) A student set up the apparatus as shown in the diagram below to prepare and collect dry ammonia gas.

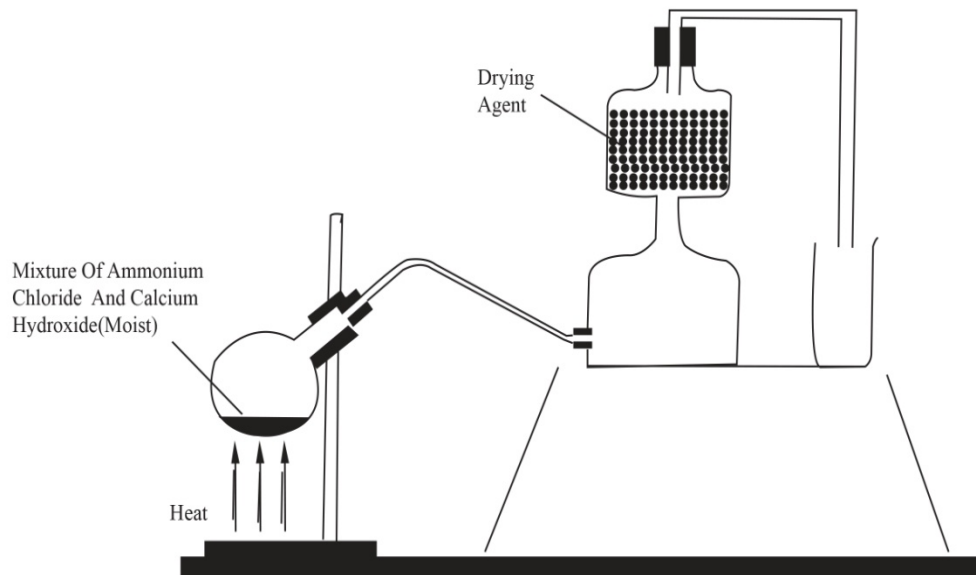

- i) Identify **two** mistakes in the set up and give a reason for each mistake. (3mks)

1. Mistake

Reason

2. Mistake

Reason

- ii) Name a suitable drying agent for ammonia (1 mk)

- iii) Write an equation for the reaction that occurred when a mixture of ammonium chloride and calcium hydrogen was heated. (1 mk)

iv) Describe **one** chemical test for ammonia gas  
(1 mk)

d) Ammonia gas is used to manufacture nitric (V) acid, as shown below.

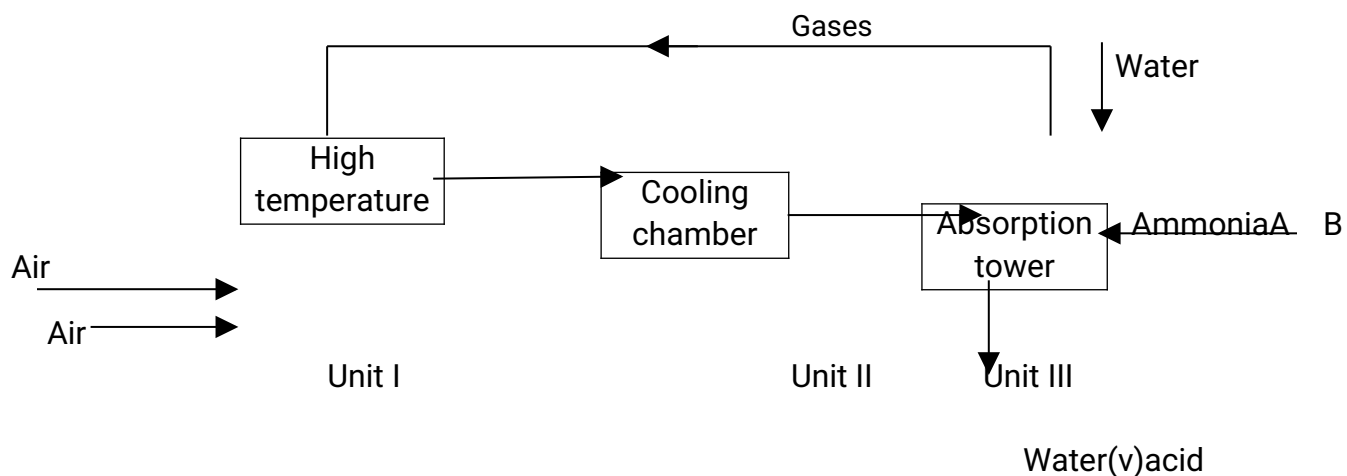

i) This process requires the use of a catalyst. In which unit is the catalyst used  
(1 mk)

ii) Identify compound **A** and **B** (1 mk)

iii) Using oxidation number, explain why the conversion of ammonia to nitric(V) acid is called catalytic oxidation of ammonia  
(2mks)

iv) Ammonia and nitric(V) acid are used in the manufacture of ammonium nitrate fertilizer. Calculate the amount of nitric (V) acid required to manufacture 1000kg ammonium nitrate using excess ammonia. (3 mks)

6. The melting and boiling points of zinc are  $419^{\circ}\text{C}$  and  $907^{\circ}\text{C}$  respectively. One of the ores of zinc is blende. To extract zinc, the ore is first roasted in air before feeding it into

a furnace.

a.

i) Write the formula of the main zinc compound in zinc blende.  
(1 mk)

ii) Explain using an equation why it is necessary to roast the ore in air before introducing it into the furnace  
(2 mks)

b. The diagram below shows a simplified furnace used in the extraction of zinc. Study it and answer the questions that follows:

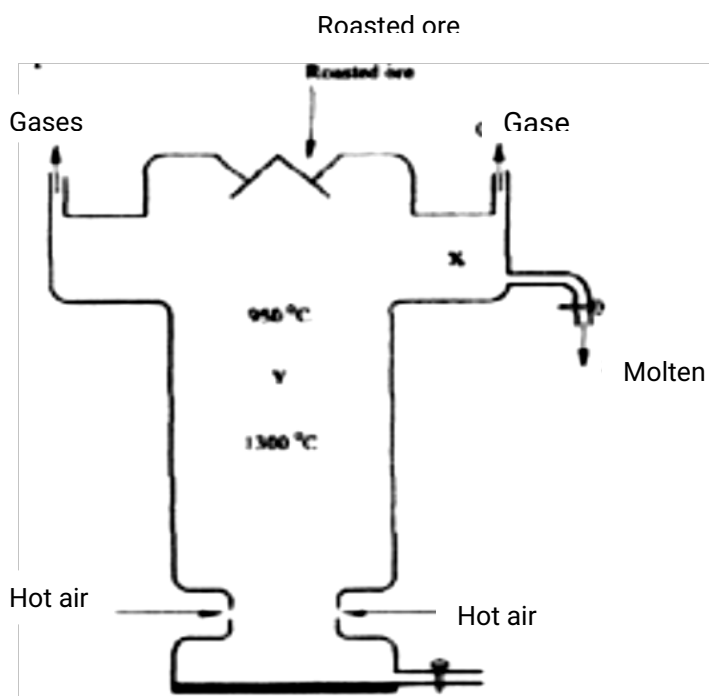

i) Name **two** other substance that are also introduced into the furnace together with roasted ore.  
(1 mk)



- ii) The main reducing agent in the furnace is carbon(II) oxide. Write **two** equations showing how it is formed. (2 mks)
- iii) In which physical state is zinc at point **Y** in the furnace? Give a reason (1 mk)
- iv) Suggest a value for the temperature at point **X** in the furnace. Give a reason. (1 mk)
- v) State and explain **one** environmental effect that may arise from the extraction of zinc from zinc blende (2 mks)
- vi) Give **two** industrial uses of zinc. (1 mk)

7. The figure below shows how the rate of the following reaction varies with the time.

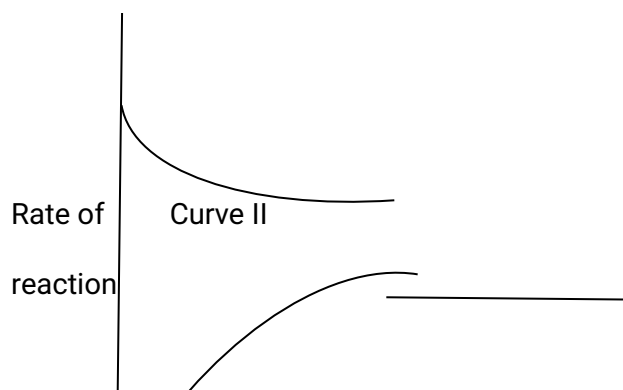
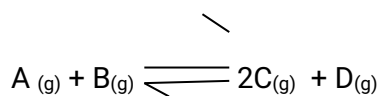

Y

Curve I

---

X Time(minutes)

- i) Which of the two curves represent the rate of the reverse reaction? Give a reason (2mks)
- ii) What is the significance of point X and Y on the figure? (2mks)
- b) State and explain the effect of an increase in pressure on the rates of the following reactions.
- i)  $\text{H}_2(\text{g}) + \text{Cl}_2(\text{g}) \longrightarrow 2\text{HCl}(\text{g})$  (2mks)
- ii)  $\text{CH}_3\text{OH}(\text{l}) + \text{CH}_3\text{COOH}(\text{l}) \longrightarrow \text{CH}_3\text{COOCH}_3(\text{l}) + \text{H}_2\text{O}(\text{l})$  (2mks)
- c) In an experiment to study the rate of reaction between barium carbonate and dilute hydrochloric acid; 1.97g of barium carbonate were reacted with excess 2M hydrochloric acid. The equation for the reaction is



The data in the table was obtained

Time in seconds	0	30	60	90	120	150	180	210	240
Volume of gas (cm <sup>3</sup> )	0	80	135	175	210	230	240	240	240

- i) On a grid plot a graph of volume of gas produced (vertical axis) against time (3 mks)
- ii) From the graph, determine the rate of the reaction at:
- (I) 15 seconds (1 mk)
  - (II) 120 seconds (1 mk)
  - (III) Give a reason for the difference between the two values. (1 mk)

# CHEMISTRY PAPER 233/2

## K.C.S.E 2011 QUESTIONS

1. The flow chart below shows some of the processes involved in large scale production of sulphuric (VI) acid. Use it to answer the questions that follow.

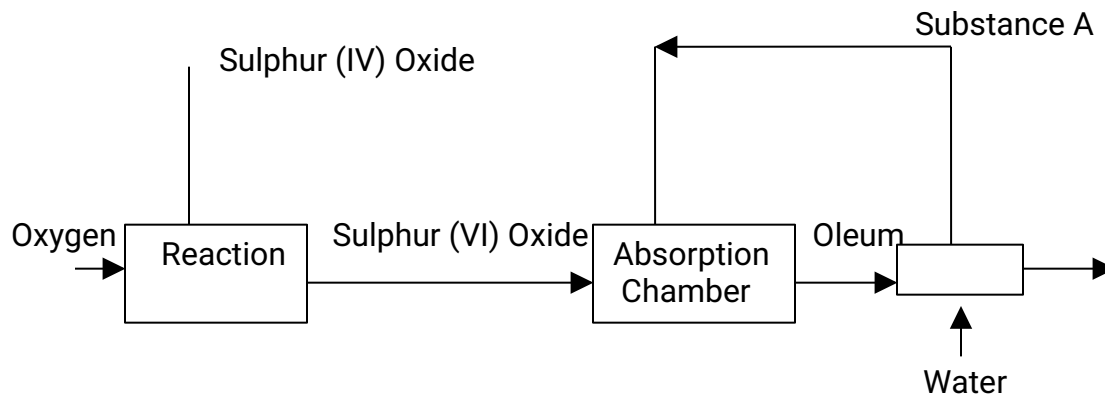

- a) Describe how oxygen is obtained from air on a large scale  
(3 mks)
- (b) (i) Name substance A.  
(ii) Write an equation for the process that takes place in the absorption chamber.  
(1mk)
- (c) Vanadium (V) oxide is a commonly used catalyst in the contact process.
- (i) Name another catalyst which can be used for this process.  
(1 mk)
- (ii) Give two reasons why vanadium (V) oxide is the commonly used catalyst.  
(2 mks)
- (d) State and explain the observations made when concentrated sulphuric (VI) acid is added to crystals of copper (II) sulphate in a beaker.  
(2 mks)
- (e) The reaction of concentrated sulphuric (VI) acid with sodium chloride produces hydrogen chloride gas. State the property of concentrated sulphuric (VI) acid, illustrated in this reaction. (1mk)
- (f) Name four uses of sulphuric (VI) acid

2. The set-up below was used by a student to investigate the products formed when aqueous copper (II) chloride was electrolysed using carbon electrodes.

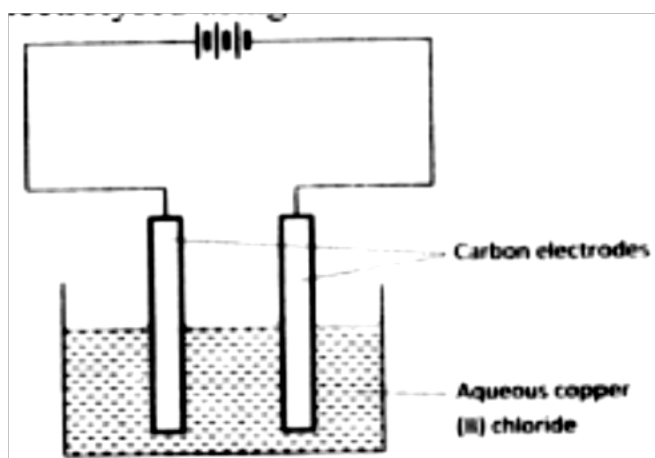

- (a) (i) Write the equation for the reaction that takes place at the cathode.  
(1 mk)
- (ii) Name and describe a chemical test for the product initially formed at the anode when a highly concentrated solution of copper (II) chloride is electrolysed. (3 mks)
- (iii) How would the mass of the anode change if the carbon anode was replaced With copper metal? Explain.  
(2mks)
- (b) 0.6 g of metal B were deposited when a current of 0.45A was passed through an electrolyte for 72 minutes. Determine the charge on the ion of metal B.  
(Relative atomic mass of B = 59, 1 Faraday = 96 500 coulombs)  
(3 mks)
- (c) The electrode potentials for cadmium and zinc are given below:

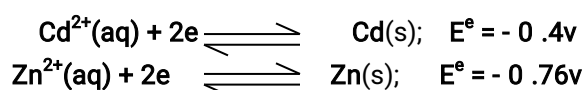

why it is not advisable to store a solution of cadmium nitrate in a container made of zinc

(2mks)

3. (a) Ethanol can be manufactured from ethene and steam as shown in the equation below:

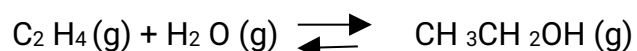

Temperature and pressure will affect the position of equilibrium of the above reaction. Name the other factor that will affect the position of equilibrium of the above reaction.

(1 mk)

- (b) The data in the table below was recorded when one mole of ethene was reacted with excess steam. The amount of ethanol in the equilibrium mixture was recorded under different conditions of temperature and pressure. Use the data to answer the questions that follow.

Temperature (°C)	Pressure (Atm)	Amount of ethanol at equilibrium (Moles)
300	50	0.40
300	60	0.46
300	70	0.55
250	50	0.42
350	50	0.38

- (i) State whether the reaction between ethene and steam is exothermic or endothermic.

Explain your answer.

(3 mks)

- (ii) State and explain **one** advantage and one disadvantage of using extremely high pressure in this reaction.

I Advantage

II disadvantage

- (c) In an experiment to determine the rate of reaction between calcium carbonate and dilute hydrochloric acid, 2g of calcium carbonate were reacted with excess 2 M hydrochloric acid, The volume of carbon (IV) oxide evolved was recorded at regular intervals of one minute for six minutes. The results are shown in the table below.

Time (minutes)	1	2	3	4	5	6
Volume of carbon (IV) oxide (cm <sup>3</sup> )	170	296	405	465	480	480

- (i) plot a graph of time in minutes on the horizontal axis against volume of carbon (IV) oxide on the vertical axis.
- (ii) determine the rate of reaction at 4 minutes  
(2mks)
4. (a) When excess calcium metal was added to 50 cm<sup>3</sup> of 2 M aqueous copper (II) nitrate in a beaker, a brown solid and bubbles of gas were observed.
- (i) "Write two equations for the reactions which occurred in the beaker.  
(2 mks)
- (ii) Explain why it is not advisable to use sodium metal for this reaction.
- (b) Calculate the mass of calcium metal which reacted with copper (II) nitrate solution. (Relative atomic mass of Ca = 40) (2 mks)

(c) The resulting mixture in (a) above was filtered and sodium hydroxide added to the filtrate dropwise until in excess. What observations were made?  
(1mk)

(d) (i) Starting with calcium oxide, describe how a solid sample of calcium carbonate can be prepared.

(ii) Name one use of calcium carbonate

5. (a) Other than their location in the atom, name two other differences between an electron and a proton.

(b) the table below gives the number of electrons ,protons and neutrons in particles A,B, C , D, E, F and G

particle	Protons	electrons	neutrons
A	6	6	6
B	10	10	12
C	12	10	12
D	6	6	8
E	13	10	14
F	17	17	18
G	8	10	8

(i) Which particle is likely to be a halogen? (1 mk)

(ii) what is the mass number of E

(iii) write the formula of the compound formed when E combines with G  
(1 mk)

iv) Name the type of bond formed in (iii) above.

(v) How does the radii of C and E compare ? Give reason.  
(2mks)

(vi) Draw a dot (.) and cross(x) diagram for the compound formed between

(1mk)

(vii) Why would particle B not react with particle D?  
(1mk)



6.

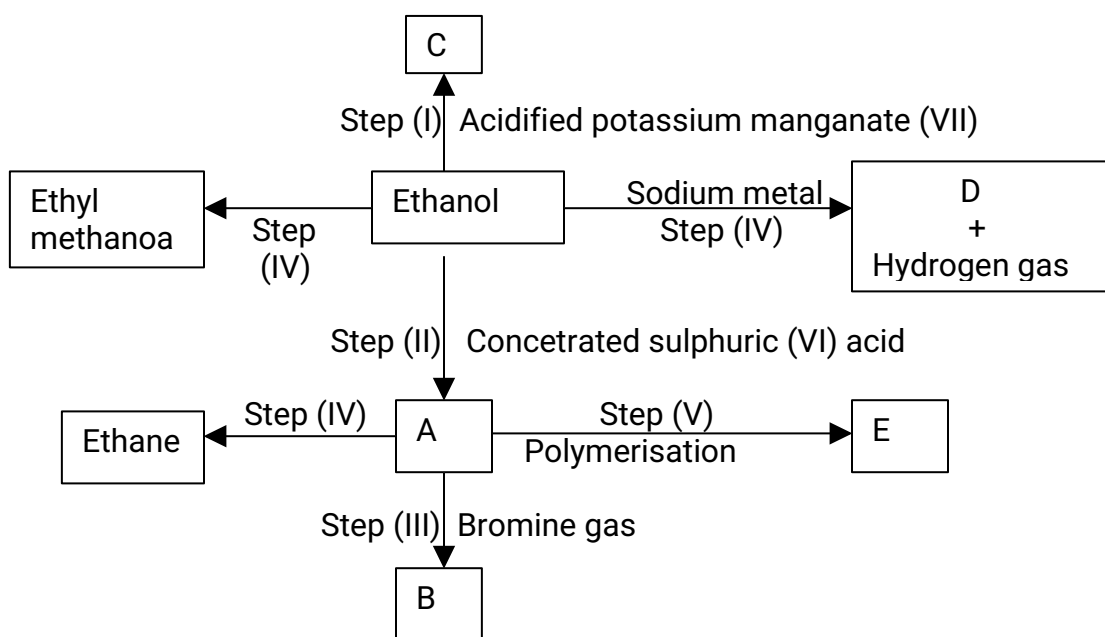

(i) I What observation will be made in Step I  
(1 mk)

II Describe a chemical test that can be carried out to show the identity of compound C

(2 mk)

(ii) Give the names of the following

I E.....

(2 mk)

II substance D ..... (1 mk)

(iii) Give the formula of substance B .

(iv) Name the type of reaction that occurs in:

I Step (II)

II Step (IV)

(v) Give the reagent and conditions necessary for Step (VI).

Reagent:

Conditions

(b) (i) Name the following structure.

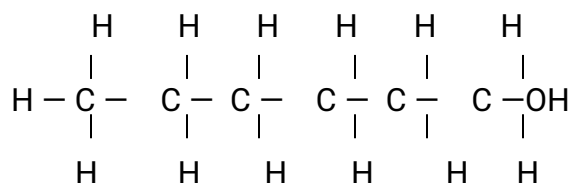

(ii) Draw the structure of an isomer of pentene.

7. (a) What is meant by molar heat of combustion?

(1 mk)

(b) State the Hess's Law.

c) Use the following standard enthalpies of combustion of graphite, hydrogen and enthalpy of formation of propane.

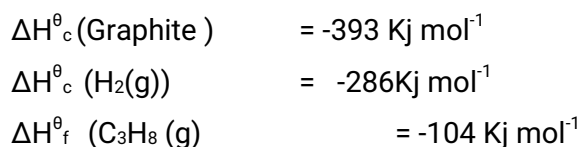

(i) Write the equation for the formation of propane. (1 mk)

(ii) Draw an energy cycle diagram that links the heat of formation of propane

with its heat of combustion and the heats of combustion of graphite and hydrogen.

- (iii) Calculate the standard heat of combustion of propane.  
(2 mks)

Other than the enthalpy of combustion, state **one** factor which should be considered when choosing a fuel. (1 mk)

- (e) The molar enthalpies of neutralization for dilute hydrochloric acid and dilute nitric (V) acid are  $-57.2\text{kJ/mol}$  while that of ethanoic acid is  $-55.2\text{kJ/mol}$ . Explain this observation. (2mks)

## CHEMISTRY PAPER 233/2

### K.C.S.E 2012 QUESTIONS

1. a) Draw the structural formula for all the isomers of  $\text{C}_2\text{H}_3\text{Cl}_3$   
(2mks)
- b) Describe two chemical tests that can be used to distinguish between ethane and ethene. (4mks)
- c) The following scheme represents various reactions starting with propan-1-ol. Use it to answer the questions that follow.

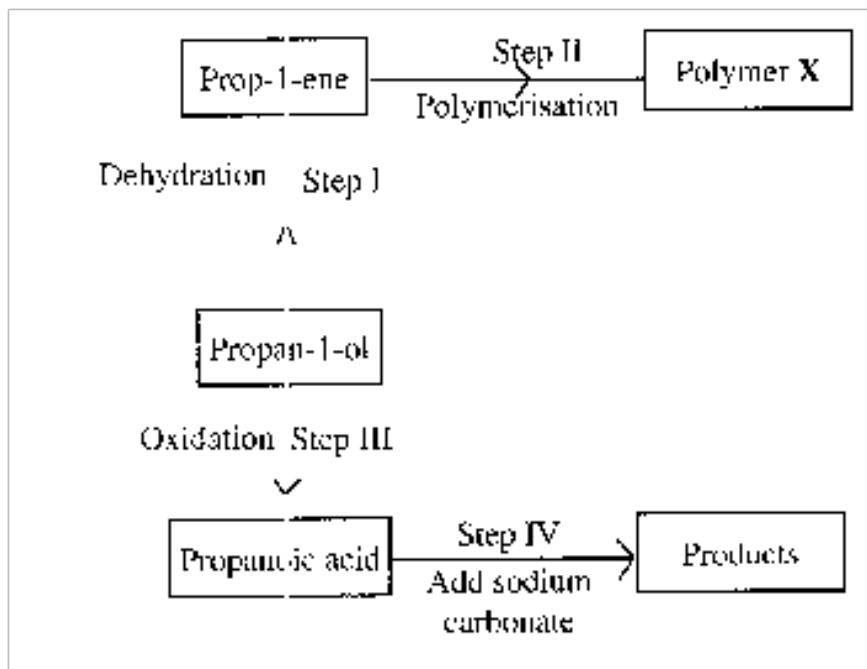

- i) Name one substance that can be used in step I. (1mk)
- ii) Give the general formula of X. (1 mk)
- iii) Write the equation for the reaction in step IV. (1mk)
- iv) Calculate the mass of propan-1-ol which when burnt completely in air at room temperature and pressure would produce  $18\text{dm}^3$  of gas. (C = 12.0; O = 16.0; H = 1.0; Molar gas volume =  $24\text{dm}^3$ ) (3mks)

2. The grid below is part of the periodic table. Use it to answer the questions that follow. (The letters are not the actual symbols of the elements.)

				A		B	C
D				E	F		G
							H

- a) Which is the most reactive non-metallic element shown in the table? Explain.  
(2mks)
- b) i) Write the formula of the compound formed when element A reacts with element B. (1mk)
- ii) Name the bond type in the compound formed in b (i) above. (1mk)
- c) i) What is the name given to the group of elements where C, G and H belong?  
(1mk)
- ii) Write an equation for the reaction that occurs when C in gaseous form is passed through a solution containing ions of element H.  
(2mks)
- d) The melting points of elements F and G are  $1410^{\circ}\text{C}$  and  $-101^{\circ}\text{C}$  respectively. In terms of structure and bonding, explain why there is a large difference in the melting points of F and G. (2mks)
- e) D forms two oxides. Write the formula of each of the two oxides.  
(1mk)
- f) J is an element that belongs to the 3<sup>rd</sup> period of the periodic table and a member of the alkaline earth elements. Show the position of J in the grid.  
(1mk)

3. In the laboratory, small quantities of nitric (V) acid can be generated using the following set up. Study it and answer the questions that follow.

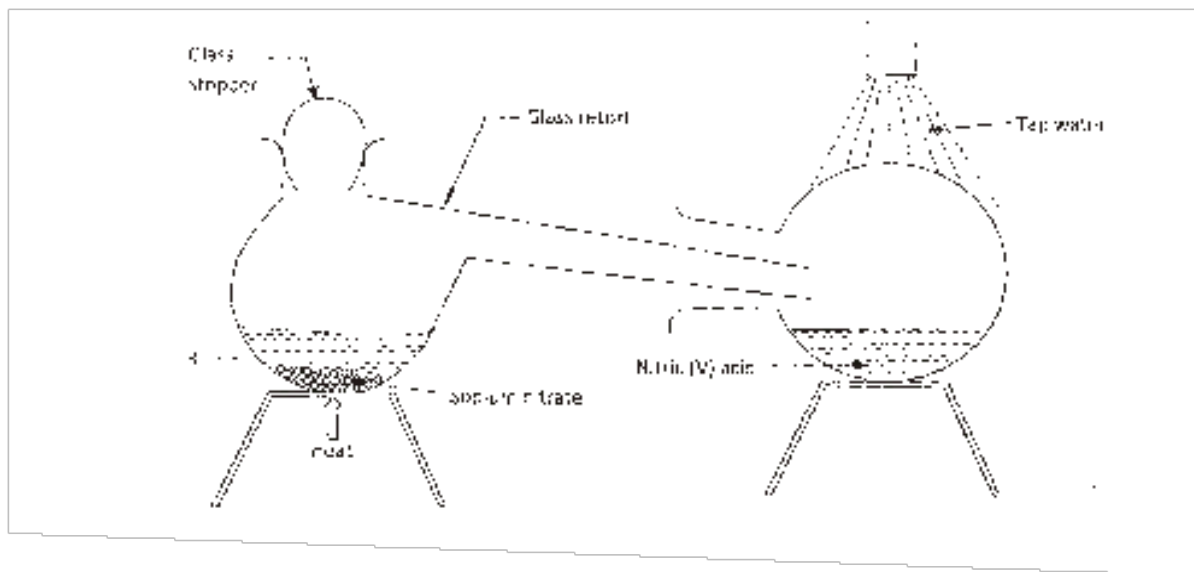

- a) i) Give the name of substance R. (1mk)
- ii) Name one other substance that can be used in place of sodium nitrate. (1mk)
- iii) What is the purpose of using tap water in the set up above? (1mk)
- b) Explain the following;
- i) It is not advisable to use a stopper made of rubber in the set-up (1mk)
- ii) the reaction between copper metal with 50% nitric (V) acid in an open test-tube produces brown fumes. (1mk)
- c) i) Nitrogen is one of the reactants used in the production of ammonia, name two sources of the other reactant. (2mks)
- ii) A factory uses nitric (V) acid and ammonia gas in the preparation of a fertilizer. If the daily production of the fertilizer is 4800kg; calculate the mass of ammonia gas used in kg. (N = 14.0; O = 16.0; H = 1.0) (3mks)

- iii) State two other uses of nitric (V) acid other than the production of fertilizers. (2mks)

4. The factors which affect the rate of reaction between lead carbonate and dilute nitric (V) acid were investigated by carrying out three experiments;

Experiment number	Lead carbonate	Concentration of nitric (V) acid
1	Lumps	4M
2	Powdered	4M
3	Lumps	2M

- a) Other than concentration, name the factor that was investigated in the experiments. (1mk)
- b) For each experiment, the same volume of acid (excess) and mass of lead carbonate were used and the volume of gas liberated measured with time.
- i) Draw a set up that can be used to investigate the rate of reaction for one of the experiments. (3mks)
- ii) On the grid provided, sketch the curves obtained when the volume of gas produced was plotted against time for each of the three experiments and label each as 1, 2 or 3. (4mks)

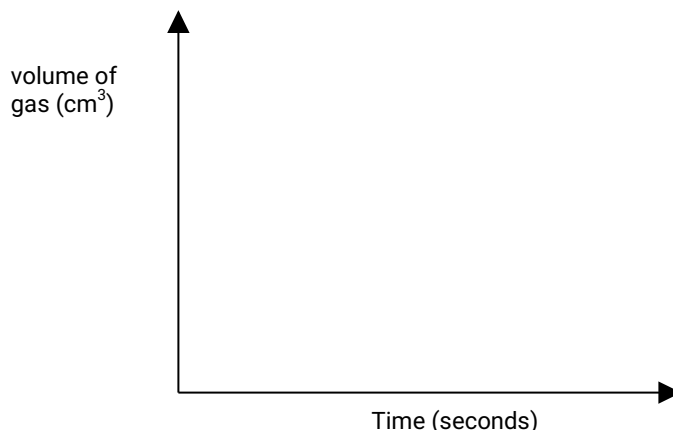

- iii) Write an equation for the reaction that took place. (1mk)

- c) If the experiments were carried out using dilute hydrochloric acid in place of dilute nitric (V) acid, the reaction would start, slow down and eventually stop. Explain these observations. (2mks)

- d) A solution of bromine gas in water is an example of a chemical reaction in a state of balance. The reaction involved is represented by the equation below.

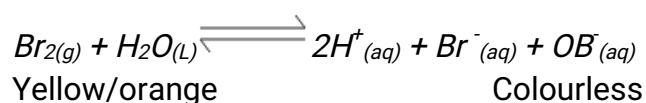

State and explain the observation made when hydrochloric acid is added to the mixture at equilibrium.

(2mks)

5. a) The set up below was used to investigate the products formed at electrodes during electrolysis of aqueous magnesium sulphate using inert electrodes. Use it to answer the questions that follow.

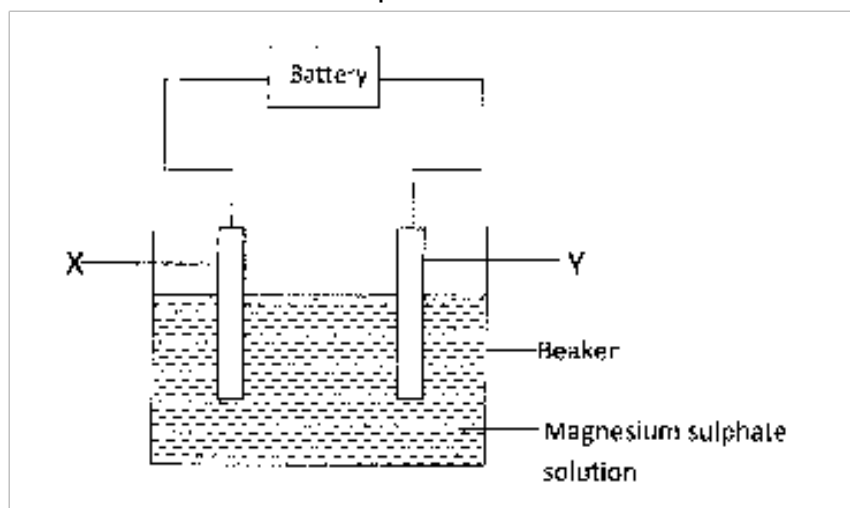

- i) During the electrolysis, hydrogen gas was formed at electrode Y. identify the anode. Give a reason for your answer. (2mks)
- ii) Write the equation for the reaction which takes place at electrode X.



(1mk)

iii) Why is the concentration of magnesium sulphate expected to increase during electrolysis?

(2mks)

iv) What will be observed if red and blue litmus papers were dipped into the solution after electrolysis?

(2mks)

b) During electrolysis of magnesium sulphate, a current of 0.3A was passed for 30 minutes. Calculate the volume of gas produced at the anode.

(Molar gas volume =  $24\text{dm}^3$ ; 1 Faraday =  $96,500\text{C}$ .)

(3mks)

c) State two applications of electrolysis.

(1mk)

6. The flow chart below shows a sequence of reactions involving a mixture of two salts, mixture M. Study it and answer the questions that follow.

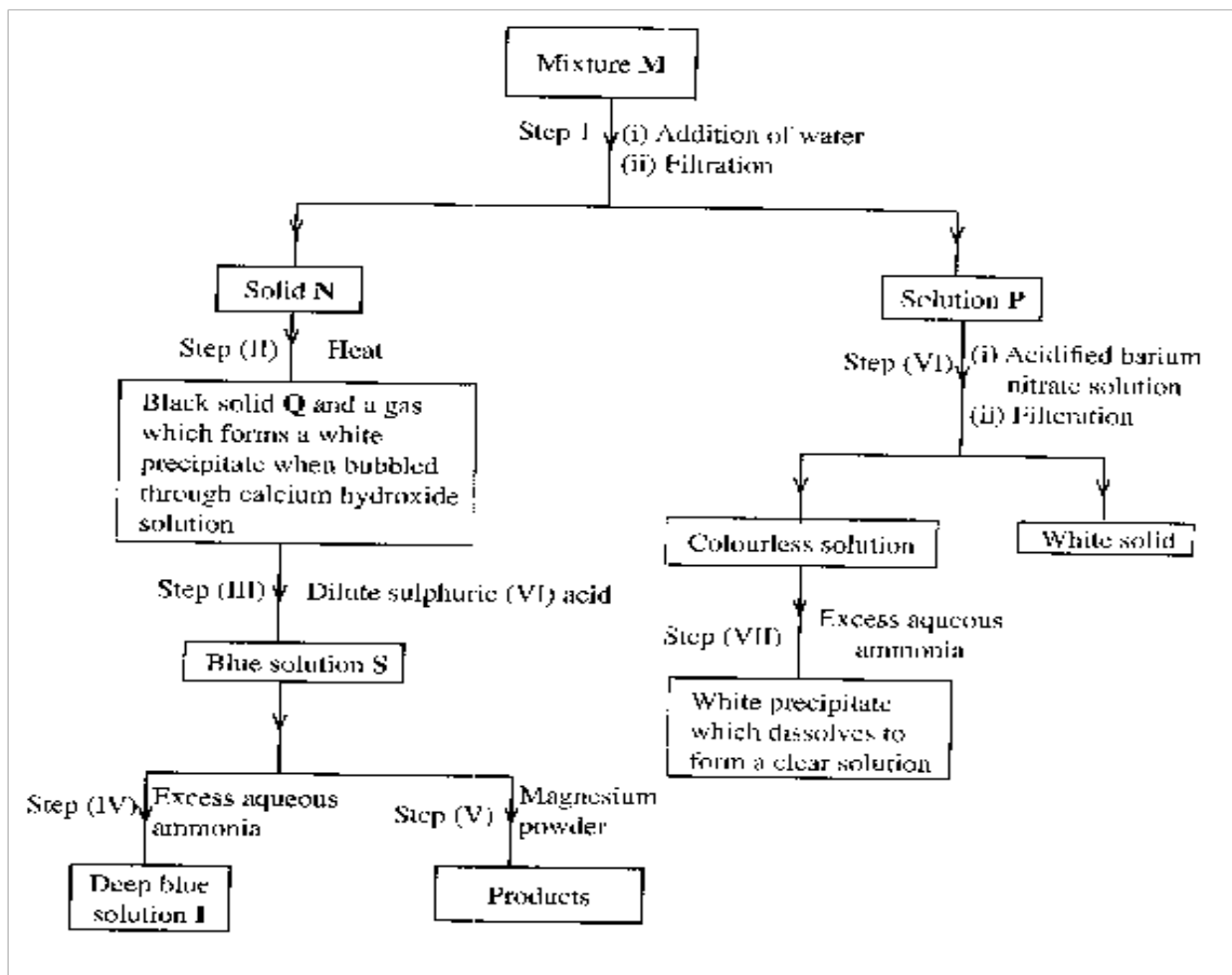

- a) Write the formula of the following;
- i) anion in solid Q (1mk)
- ii) the two salts present in mixture M. (2mks)

b) Write an ionic equation for the reaction in step (VI) (1mk)

c) State and explain the observations made in step (V). (3mks)

d) i) Starting with Lead (II) oxide, describe how a pure solid sample of lead sulphate can be prepared in the laboratory. (2mks)

ii) How can one determine whether the lead sulphate prepared is pure? (2mks)

7. a) The diagram below is part of set up used to prepare and collect dry chlorine gas.

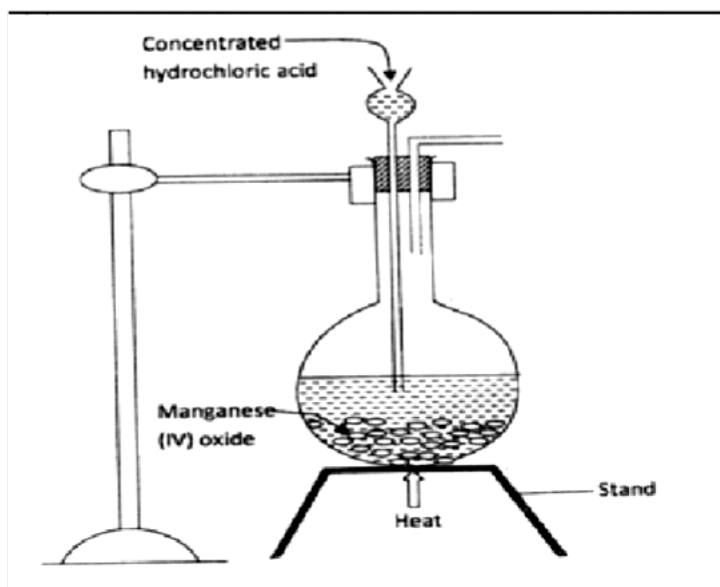

i) Complete the diagram to show how a dry sample of chlorine gas can be collected. (3mks)

ii) Name another substance and condition that can be used instead of manganese (VI) oxide. (1mk)

iii) Write an equation for each of the following;

I. chlorine gas reacting with iron

(1 mk)

II. chlorine gas reacting with hot concentrated sodium hydroxide solution.

(1mk)

b) An oxide of chlorine of mass 1.83g was found to contain 1.12g of oxygen.  
Determine the empirical formula of the oxide (O = 16.0; Cl = 35.5).

(3mks)

c) Other than the manufacture of weed killers, name two other uses of chlorine.  
(2mks)

## CHEMISTRY PAPER 233/2 K.C.S.E 2013 QUESTIONS

1. The grid given below represents part of the periodic table. Study it and answer the questions that follow. The letters do not represent the actual symbol of the element

M				N	P	T		
R								

(i) Select a letter which represents an element that loses electrons most readily.  
Give a reason for your answer.

(2mks)

(ii) Explain why the atomic radius of P is found to be smaller than that of N

(2mks)

(iii) Element **M** reacts with water at room temperature to produce  $0.2 \text{ dm}^3$  of gas.

Determine the mass of **M** which was reacted with water. (molar gas volume at room temperature is  $24 \text{ dm}^3$ , relative atomic mass of  $M=7$ ) (3mks)

(b) Use the information in the table below to answer the question that follows. (The letters are not the symbols of the elements)

Element	State of oxide at room temperature	Type of oxide	Bonding in oxide
U	Solid	Acidic	Covalent
W	Solid	Basic	Ionic
X	Liquid	Neutral	Covalent
Y	gas	neutral	covalent

Identify a letter which represents an element in the table that could be calcium, carbon or sulphur. Give reasons in each case.

(i) Calcium: (2mks)

Reason

(ii) Carbon (2mks)

Reason

(iii) Sulphur: (2mks)

Reason

2. (a) (i) what is meant by the term Enthalpy of formation? (1mk)

(ii) The enthalpies of combustion of carbon, methane and hydrogen are indicated below:

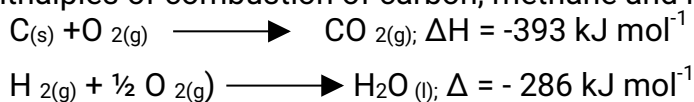

Enthalpy of combustion of  $\text{CH}_4 = -890 \text{ kJ mol}^{-1}$

(i) Draw an energy cycle diagram that links the enthalpy of formation of methane to enthalpies of combustion of carbon, hydrogen and methane (2mks)

(ii) Determine the enthalpy of formation of methane (2mks)

(b) An experiment was carried out where different volumes of dilute hydrochloric acid and aqueous sodium hydroxide both at  $25^\circ\text{C}$  were mixed and stirred with a thermometer. The highest temperature reached by each mixture was recorded in the table below

Volume of hydrochloric acid ( $\text{cm}^3$ )	5	10	15	20	25	30	35	40	45
Volume of sodium hydroxide ( $\text{cm}^3$ )	45	40	35	30	25	20	15	10	5
Highest temperature of mixture ( $^\circ\text{C}$ )	27.2	29.4	31.6	33.8	33.6	31.8	30.0	28.4	26.6

(i) On the grid provided, plot a graph of highest temperature (vertical axis) against volume of hydrochloric acid (horizontal axis) (3mks)

(ii) Using your graph, determine the

(a) Highest temperature reached ( $^{1/2}\text{mk}$ )

(b) Volume of acid and base reacting when highest temperature is reached ( $^{1/2}\text{mk}$ )

(iii) Calculate the amount of heat liberated during the neutralization process. (specify heat capacity is  $4.2 \text{ J g}^{-1} \text{ K}^{-1}$  and the density of solution is  $1.0 \text{ g cm}^{-3}$ ) (2mks)

- (c). The molar enthalpy of neutralization between hydrochloric acid and ammonia solution was found to be  $-52.2 \text{ kJ mol}^{-1}$ , while that of hydrochloric acid and sodium hydroxide was  $-57.1 \text{ kJ mol}^{-1}$ . Explain the difference in these values. (2mks)

3. (a) The diagram below shows the Frasch process used for extraction of sulphur. Use it to answer the question that follows

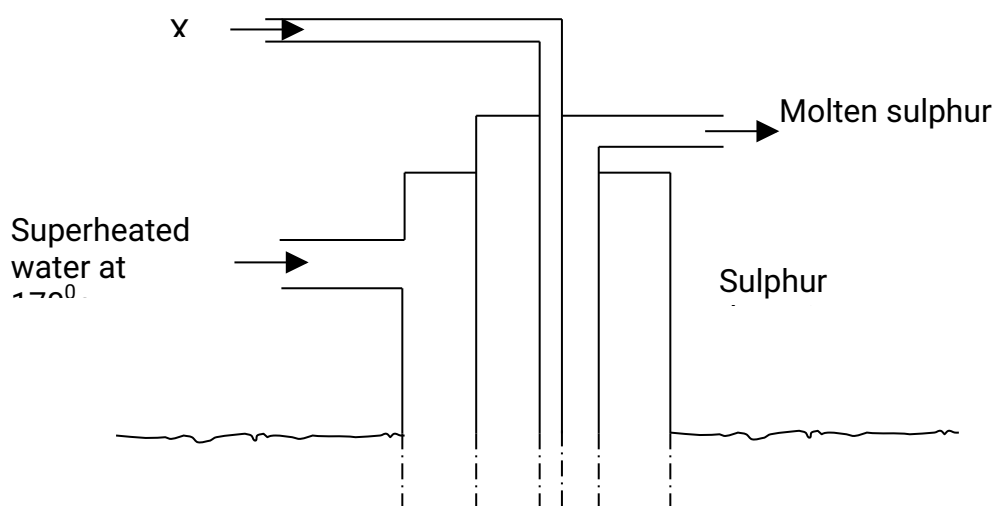

- (i) Identify X (1mk)
- (ii) Why is it necessary to use superheated water in this process (1mk)
- (iii) State two physical properties of sulphur that makes it possible for it to be extracted by this method (2mks)

(b) The diagram below shows part of the process in the manufacture of sulphuric (VI) acid. Study it and answer the questions that follow

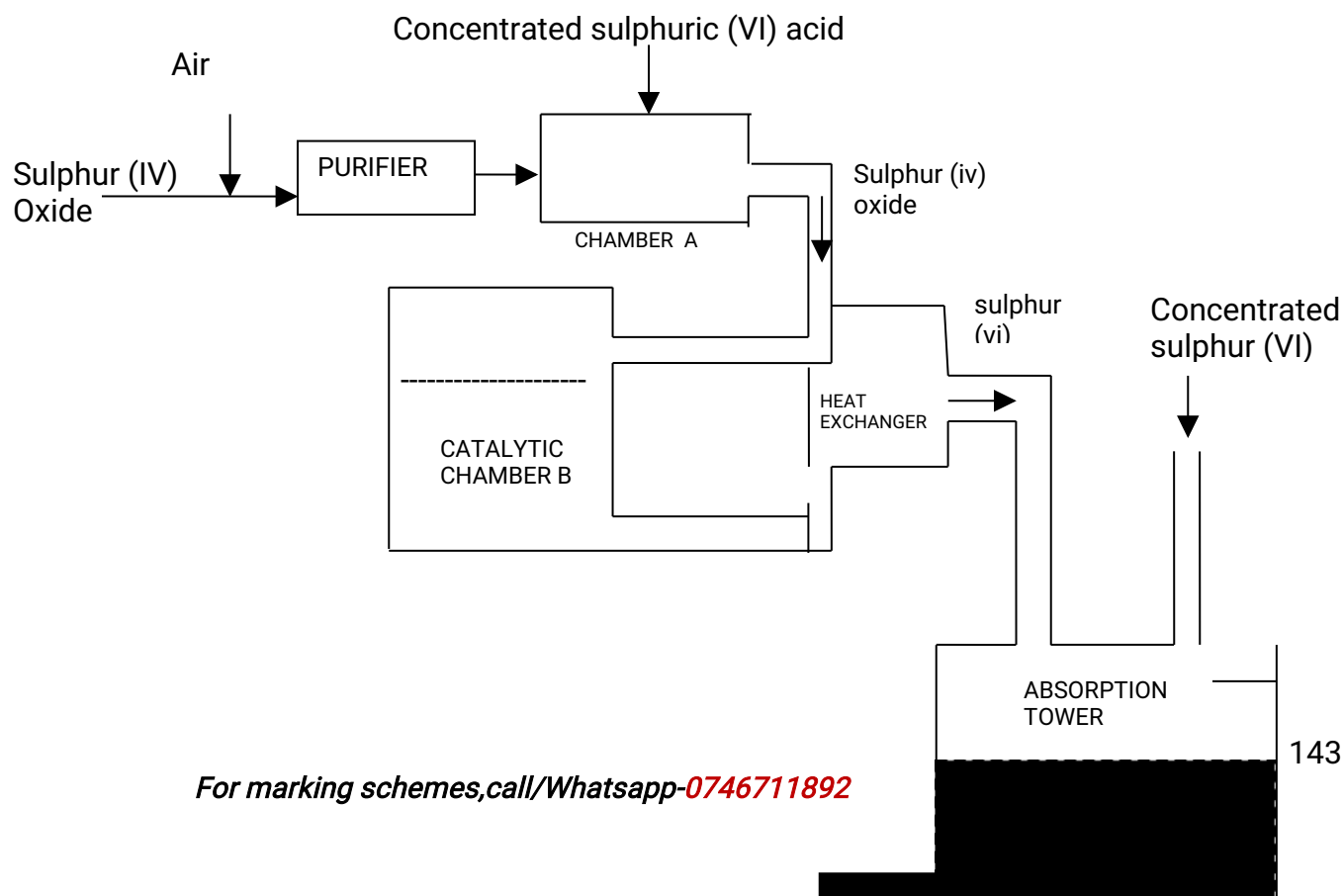

- (I) Write an equation for the formation of sulphur (IV) oxide from sulphur (1mk)
- (II) What is the role of concentrated sulphur (VI) acid in chamber A? (1 mk)
- (III) Name two catalysts that can be used in the catalytic chamber B. (2 mks)
- (IV) State two roles of the heat exchanger (1 mk)

(c) Explain one way in which sulphur (IV) oxide is a pollutant (1mk)

(d).what observation will be made when a few drops of concentrated sulphuric (VI) acid are added to crystals of sugar? Explain your answer (1 mk)

4. (a) the set below can be used to produce sodium hydroxide by electrolyzing brine

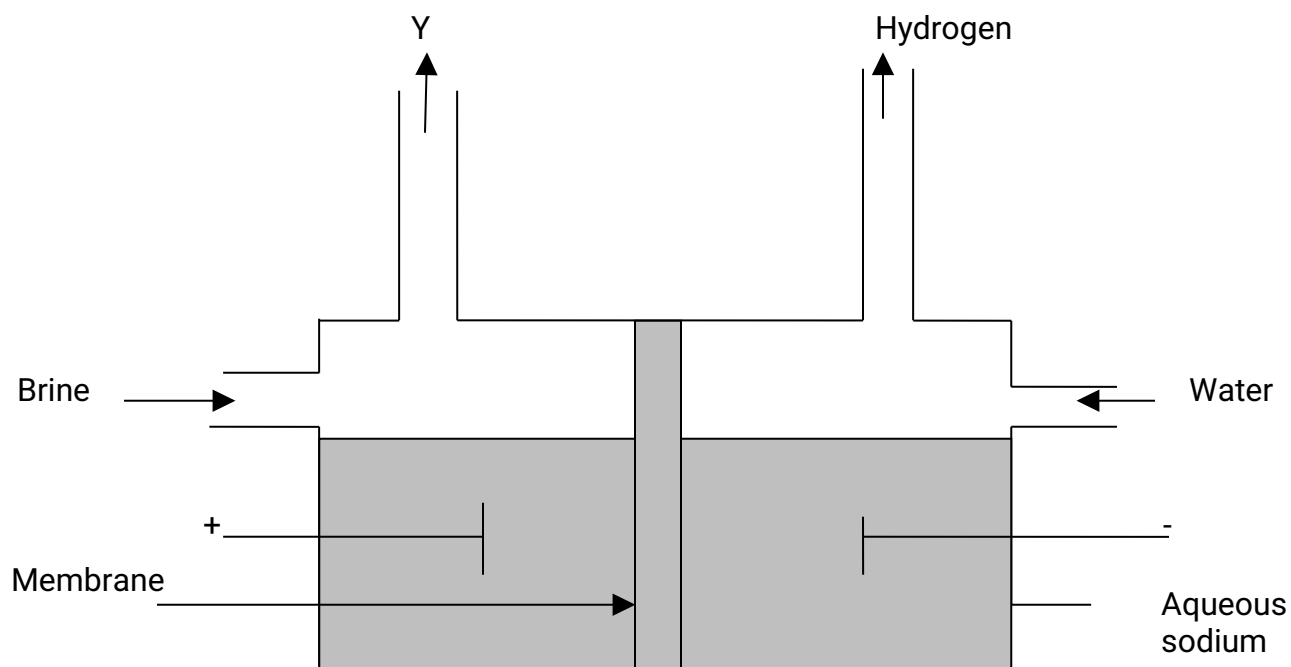





(i) Identify gas Y

(1 mk)

(ii) Describe how aqueous sodium hydroxide is formed in the above set-up  
(2mks)

(iii) One of the uses of sodium hydroxide is in the manufacturing of soaps state one other use of sodium hydroxide  
(1 mk)

(b).study the information given in the table below and answer the question that follows

Half reaction	Electrode potential $E^{\circ}V$
$D^{2+}_{(aq)} + 2e \longrightarrow D_s$	-0.13
$E^{+}_{(aq)} + e \longrightarrow E_s$	+0.80
$F^{3+}_{(aq)} + e \longrightarrow F^{2+}_{aq}$	+0.68
$G^{2+}_{(aq)} + 2e \longrightarrow G_s$	-2.87
$H^{2+}_{(aq)} + 2e \longrightarrow H_s$	+0.34
$J^{+}_{(aq)} + e \longrightarrow J(s)$	-2.71

(i) Construct an electrochemical cell that will produce the largest emf  
(3mks)

(ii) Calculate the emf of the cell constructed in(i) above  
(2mks)

(iii) Why is it not advisable to store a solution containing  $E^{+}$  ions in a container made of H?  
(2mks)

5. (a) describes one method that can be used to distinguish between sodium sulphate and sodium hydrogen sulphate.  
(2mks)

b) Describe how a pure sample of lead (II) sulphate can be prepared in the laboratory starting with lead metal  
(3mks)

c) Study the flow chart below and answer the questions that follow:

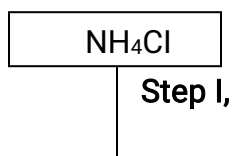

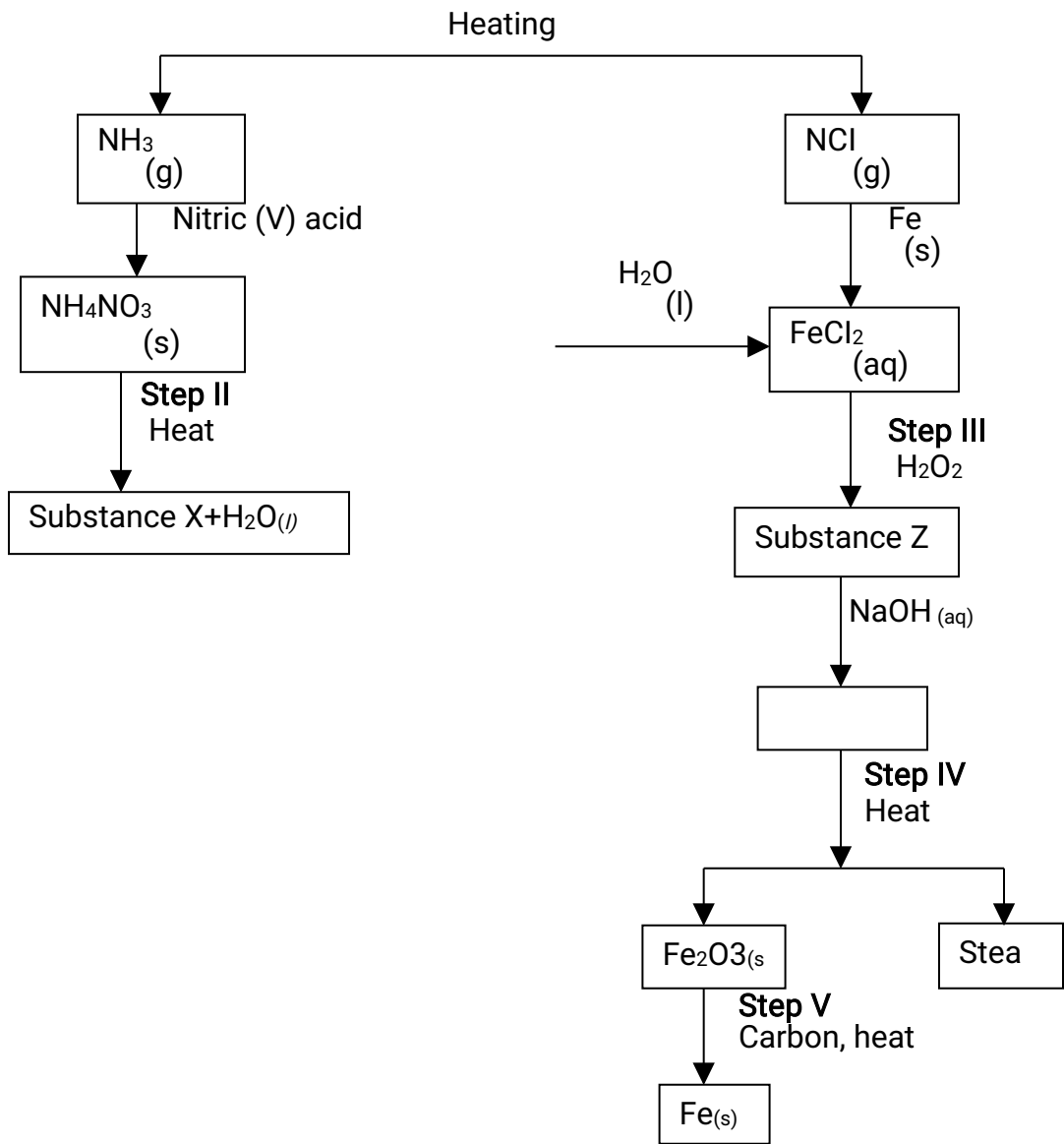

i) Write an equation for the reaction in:

I step II;

(1 mk)

II step IV

(1 mk)

ii) State the observation made in step III. Explain.

(2mks)

iii) Name another substance that can be used in step V.

(1 mk)

6. (a) distinguish between a neutron and proton

(1 mk)

(b) What is meant by a radioactive substance?

(1 mk)

(c) State two dangers associated with radioactive substance in the environment

(2mks)

(d) The two isotopes of hydrogen, deuterium  ${}^2_1\text{D}$  and tritium  ${}^3_1\text{T}$  react to form element Y and neutron particles, according to the equation below



(i) What is the atomic

- a. Mass of Y (1 mk)  
b. Number of Y (1 mk)

(ii) What name is given to the type of reaction undergone by the isotopes of hydrogen?

(1 mk)

(e).(i) What is meant by half-life of a radioactive substance

(1 mk)

(ii) 288 g of a radioactive substance decayed to 9 g in 40 days. Determine the half-life of the radioactive substance

(2mks)

7.(a) Give the systematic names for the following compounds

- (i)  $\text{CH}_3\text{CH}_2\text{COOH}$ ; (1mk)  
(ii)  $\text{CH}_3\text{CH}_2\text{CH}_2\text{CHCH}_2$ ; (1mk)  
(iii)  $\text{CHC CH}_2\text{CH}_3$ ; (1mk)

(b) Study the flow chart below and use it to answer the questions that follow

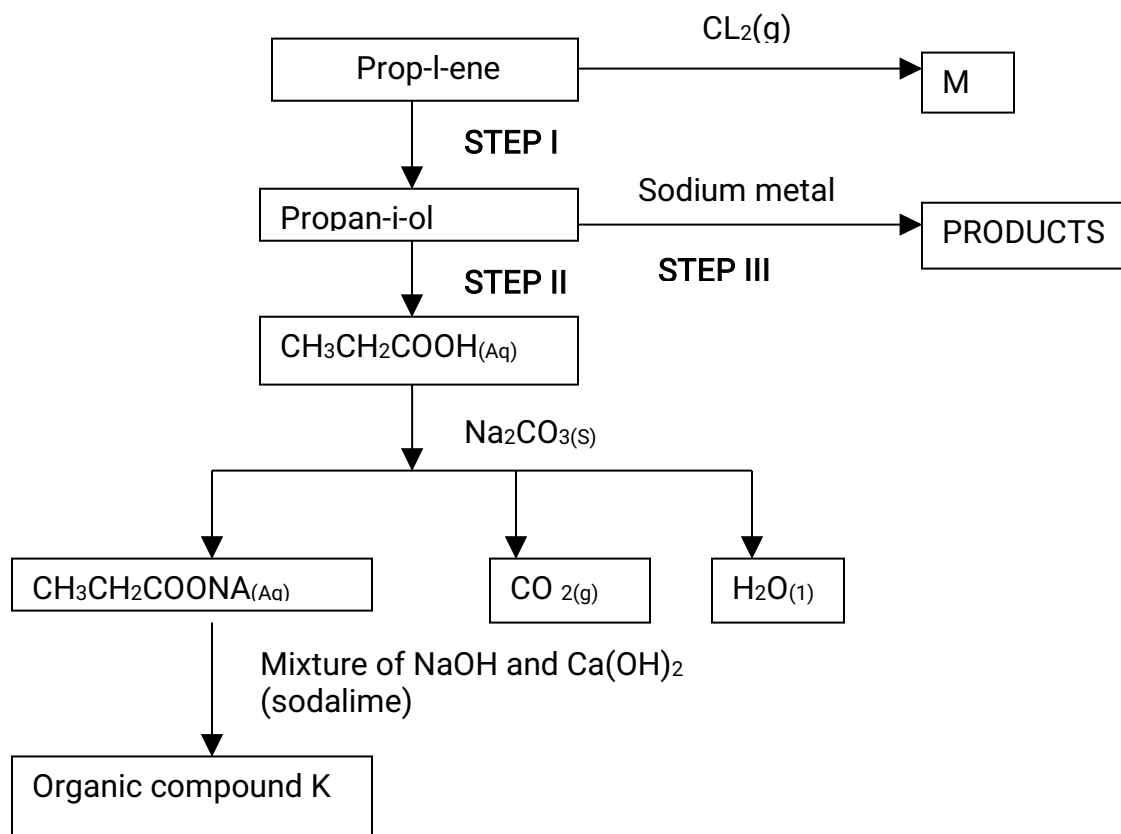

- (i) Identify the organic compound K (1 mk)
- (ii) Write the formula of M (1 mk)
- (iii) Give one reagent that can be used in
- (a) Step I (1mk)
- (b) Step II (1 mk)
- (iv) Write the equation of the reaction in step III (1 mk)

(c) The structure below represents a type of a cleaning agent

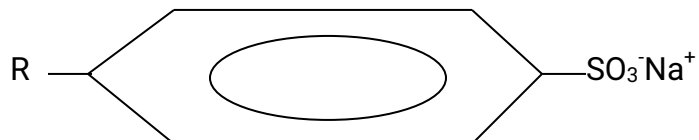

Describe how the cleansing agent removes grease from a piece of cloth

(3mks)

## CHEMISTRY PAPER 233/2 K.C.S.E 2014 QUESTIONS

1. (a) The set up below was used to prepare dry hydrogen chloride gas, and investigate its effect on heated iron filings.

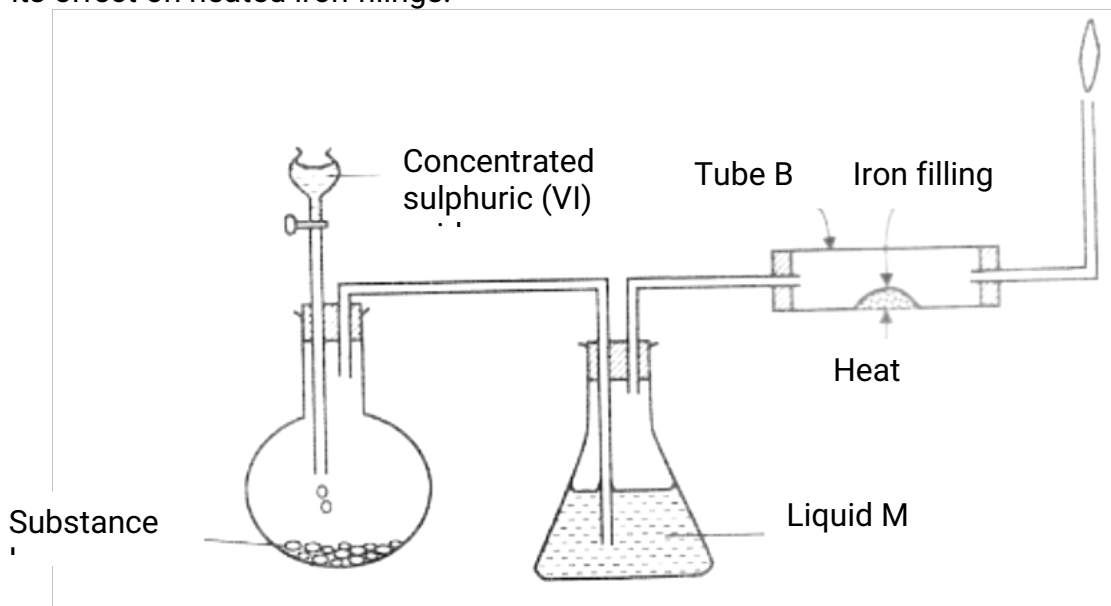

- (i). Name substance L  
(1 mk)
- (ii) Name liquid M (1 mk)
- (iii) What will be observed in tube B? (1 mk)
- (iv) Write an equation for the reaction that occurs in tube B.  
(1 mk)
- (v) Why is the gas from tube B burnt? (1 mk)
- (b) (i) Explain the following observations:  
I) A white precipitate is formed when hydrogen chloride gas is passed through aqueous silver nitrate. (1 mk)
- II) Hydrogen chloride gas fumes in ammonia gas.  
(1 mk)

- (ii) State **two** uses of hydrogen chloride gas  
(1 mk)

- (c) The diagram below is a representation of an industrial process for the manufacture of a bleaching powder.

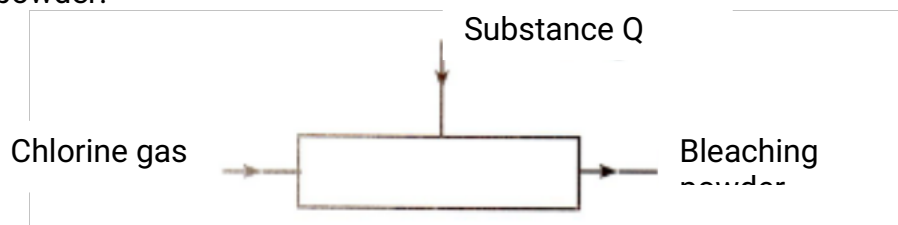

- (i) Name substance Q.  
(1 mk)

(1)

- (ii) When the bleaching powder is added to water during washing, a lot of soap is used. Explain

(1 mk)

2. (a) The grid below represents part of the periodic table. Study it and answer the questions that follow. The letters are not the actual symbols of the elements

A				B		C	
	D			E		F	G
H							

- i) Select the most reactive metal. Explain (2 mks)
- ii) Select an element that can form an ion with a charge of  $3^-$   
(1 mk)
- iii) Select an alkaline earth metal  
(1 mk)
- iv) Which group 1 element has the highest first ionization energy?  
Explain (2 mks)
- v) Element A combines with chlorine to form a chloride of A. State the most likely pH value of a solution of a chloride of A. Explain (2 mks)

(b) (i) Explain why molten calcium chloride and magnesium chloride conduct electricity while carbon tetrachloride and silicon tetrachloride do not. (2 mks)

(ii) Under the same conditions, gaseous neon was found to diffuse faster than gaseous fluorine. Explain this observation. ( $F=19.0$ ;  $Ne=20.0$ ) (2 mks)

3. (a) Draw the structures of the following.

(i) Butan-1-ol

(1 mk)

(ii) Hexanoic acid.

(1 mk)

(b) Study the flow chart below and answer the questions that follow

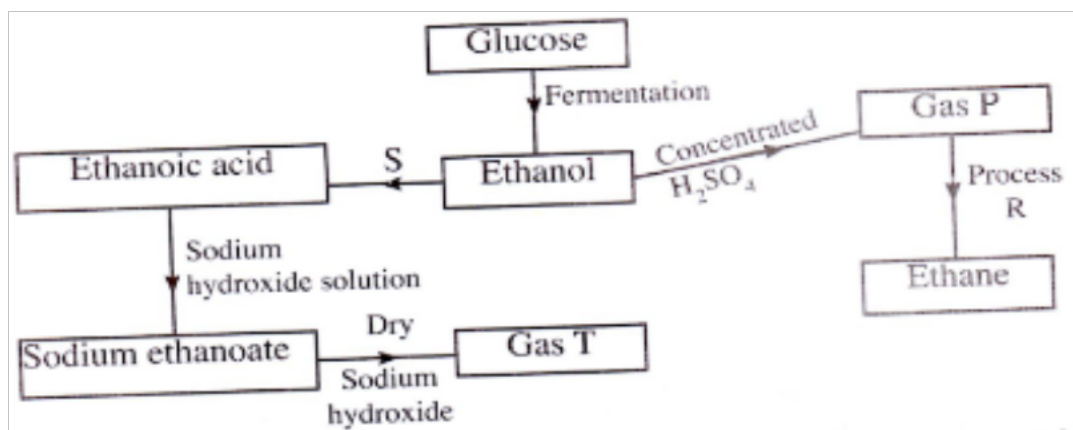

(i) State the conditions necessary for fermentation of glucose to take place (1 mk)

(ii) State **one** reagent that can be used to carry out process S. (1 mk)

(iii) Identify gases

(2 mks)

P:

T:

(iv) How is sodium hydroxide kept dry during the reaction (1 mk)

(v) Give **one** commercial use of process R. (1 mk)

(c) When one mole of ethanol is completely burnt in air, 1370kJ of heat energy is released. Given that 1 litre of ethanol is 780 g , calculate the amount of heat energy released when 1 litre of ethanol is completely burnt  
(C = 12.0; H=1.0; O=16.0)

(3 mks)

(d) State **two** uses of ethanol other than as an alcoholic drink.

(2 mks)

4. (a) Other than temperature, state **two** factors that determine the rate of a chemical reaction. (2mks)

(b) A solution of hydrogen peroxide was allowed to decompose and the oxygen gas given off collected. After 5 minute, substance **G** was added to the solution of hydrogen peroxide. The total volume of oxygen evolved was plotted against time as shown in the graph below

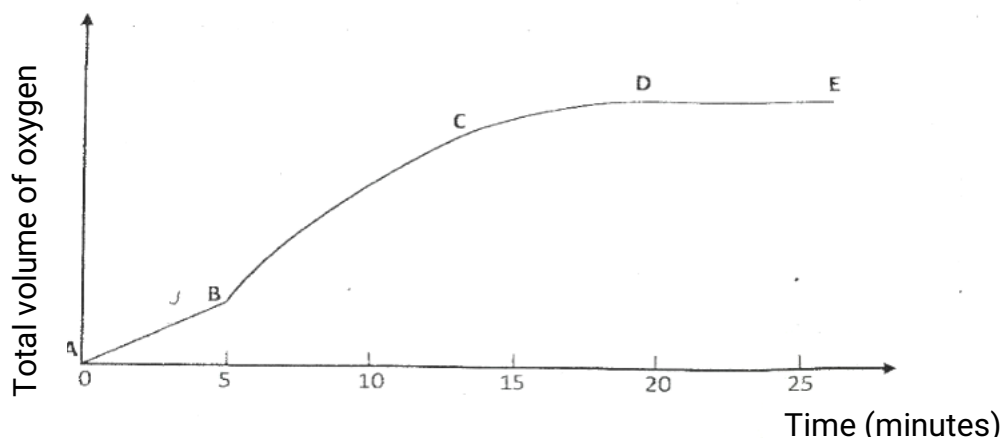

(i) Describe the procedure of determining the rate of the reaction at minute 12.  
(3mks)

(ii) How does the production of oxygen in region AB compare with that in region BC?  
Explain (2 mks)

(iii) Write an equation to show the decomposition of hydrogen peroxide.  
(1 mk)



(c) Sulphur (IV) oxide react with oxygen to form Sulphur (VI) oxide as shown in the equation below

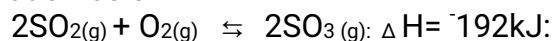

(i) Explain the effect on the yield of  $\text{SO}_3$  of lowering the temperature of this reaction. (2 mks)

(ii) Name **one** catalyst used for the reaction. (1 mk)

5. (a) The scheme below shows some of the reaction of solution D. Study it and answer the questions that follow

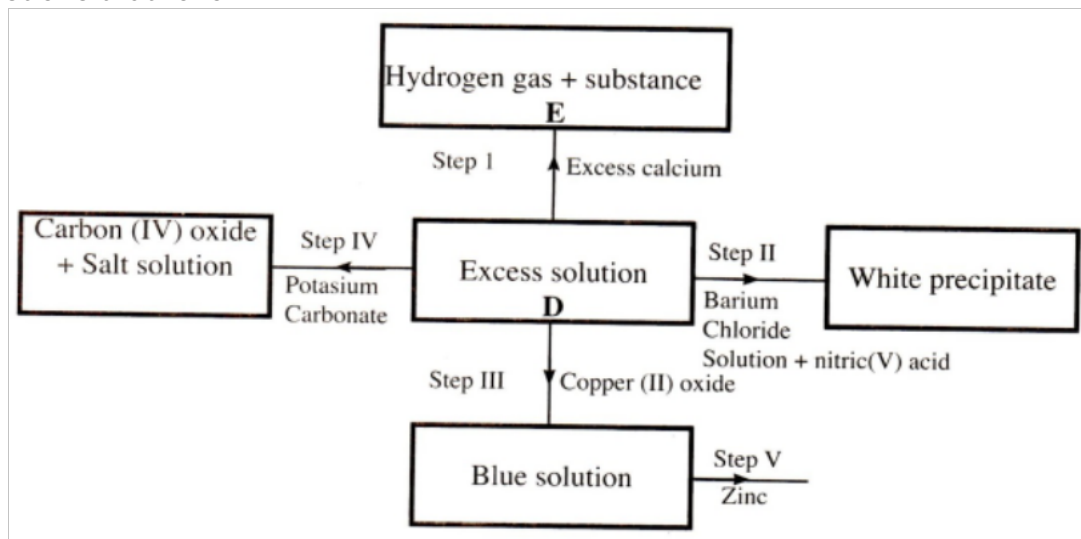

(i) Give a possible cation present in solution D (1 mk)

(ii) Write an ionic equation for the reaction in Step II (1 mk)

(iii) What observations would be made in Step V? Give a reason (2mks)

(iv) Explain why the total volume of hydrogen gas produced in step 1 was found to be very low although calcium and solution D were in excess.

(2mks)

(v) State **one** use of substance E.

(1 mk)

(b) Starting with solid sodium chloride, describe how a pure sample of lead (II) Chloride can be prepared in the laboratory (3mks)

(c) (i) State a property of anhydrous calcium chloride which makes it suitable for use as a drying agent for chlorine gas.

(1 mk)

(ii) Name another substance that can be used to dry chlorine gas

(1 mk)

6. The diagram below represents a set up of an electrolytic cell that can be used in the production of aluminium

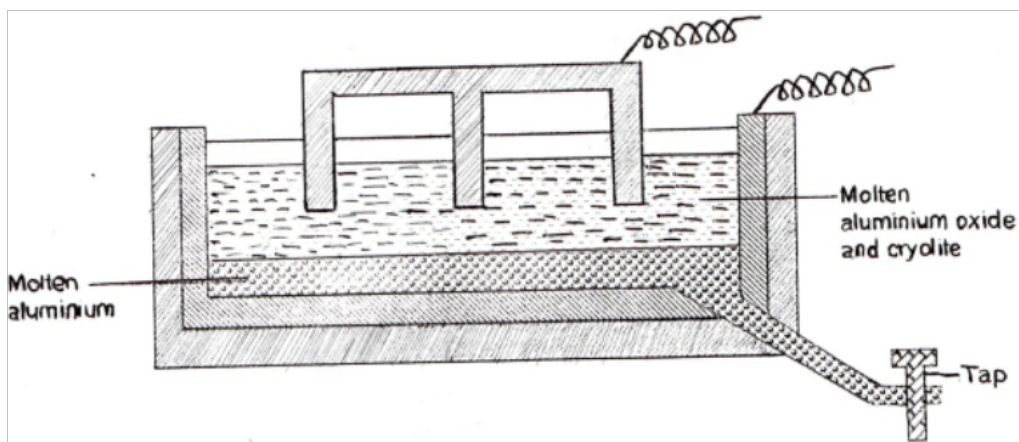

(a) One the diagram, label the anode

(1 mk)

(b) Write the equation for the reaction at the anode

(1 mk)

(c) Give a reason why the electrolytic process is not carried out below  $950^{\circ}\text{C}$   
(1 mk)

(d) Give a reason why the production of aluminium is not carried out using reduction process (1 mk)

(e) Give **two** reasons why only the aluminium ions are discharged  
(2 mks)

(f) State two properties of duralumin that makes it suitable for use in aircraft industry  
(1 mk)

(g) Name two environmental effects caused by extraction of aluminium  
(2 mks)

7a) Dissolving of potassium nitrate in water is an endothermic process. Explain the effect of increase in temperature on the solubility of potassium nitrate (2 mks)

b) The table below shows the solubilities of potassium sulphate and potassium chlorate (V) at different temperatures.

Temperature ( $^{\circ}\text{C}$ )	0	20	40	60	80	100
Solubility of $\text{K}_2\text{SO}_4$ G/100 g water	8.0	10.0	14.0	17.5	20.0	22.0
Solubility of $\text{KCIO}_3$ g/100g water	3.0	5.0	15.5	24.0	38.0	53.0

a) Draw the solubility curves for both salts on the same axis. (Temperature on the X-axis) (3 mks)

ii) A solution of potassium sulphate contains 20g of the salt dissolved in 100 g of water at  $100^{\circ}\text{C}$ . This solution is allowed to cool to  $25^{\circ}\text{C}$

i) at what temperature will crystals first appears?

ii) What mass of crystals will be present at  $25^{\circ}\text{C}$ ? (1mk)

iii) Which of the two salts is more soluble at  $30^{\circ}\text{C}$ ? (1mk)

iv) Determine the concentration of potassium sulphate in moles per litre when the

solubility of the two salts are the same (K= 39.0, O=16.0 ; S=32.0)  
(3 mks)

- v) 100 g of water at 100<sup>0</sup>C contains 19g of potassium sulphate and 19 g of potassium chlorate (V). Describe how a solid sample of potassium sulphate at 60<sup>0</sup>C can be obtained (2 mks)

## CHEMISTRY PAPER 233/2 K.C.S.E 2015 QUESTIONS

1. (a) (i) Carbon (IV) oxide is present in soft drinks. State two roles of carbon (IV) oxide in soft drinks. (1 mk)
- (ii) Explain the observation made when a bottle containing a soft drink is opened. (2 mks)
- (iii) Carbon (IV) oxide dissolves slightly in water to give an acidic solution.

Give the formula of the acid.

(1 mk)

(b) Zinc oxide can be obtained by heating zinc nitrate. A student heated 5.76 g of zinc nitrate.

(i) Write an equation for the reaction that occurred.

(1 mk)

(ii) Calculate the total volume of gases produced.

(Molar gas volume is  $24 \text{ dm}^3$ ; Zn = 65.4; O = 16.0; N = 14.0).

(4 mks)

(iii) Identify the element that is reduced when zinc nitrate is heated. Give a reason.

(2 mks)

2. (a) Draw the structure of the folio wing compounds.

(2 mks)

(i) Butanoic acid;

(ii) Pent-2-ene.

(b) Explain why propan-1-ol is soluble in water while prop-1-ene is not.

(Relative molecular mass of propan-1-ol is 60 while that of prop-1-ene is 42).

(2 mks)

(c) What would be observed if a few drops of acidified potassium manganate (VII) were added to oil obtained from nut seeds? Explain.

(2 mks)

(d) State one method that can be used to convert liquid oil from nut seeds into solid.

(1mk)

(e) Describe how soap is manufactured from liquid oil from nut seeds

(f) 0.44 g of an ester A reacts with  $62.5 \text{ cm}^3$  of 0.08 M potassium hydroxide giving an alcohol and substance C. Given that one mole of the ester reacts with one mole of the alkali, calculate the relative molecular mass of the ester.

(2 mks)



d i) Classify the substances water, iodine, diamond and candle wax into elements and compounds

(2 mks)

Elements	Compounds

ii) Give one use of diamond

(1 mk)

4a) The diagram below represents a dry cell. Use it to answer the questions that follows.

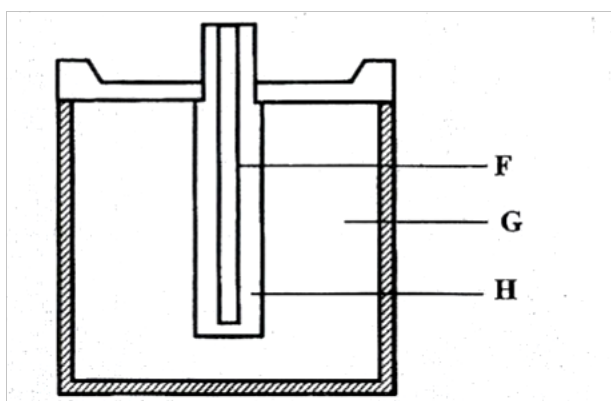

i) Which of the letters represent

i) Carbon electrode?

(1 mk)

ii) The electrolyte?

(1 mk)

ii) One of the substances used in a dry cell is manganese (IV) oxide. State two roles of manganese (IV) oxide in the dry cells

(2 mks)

b) Below is simplified electrolytic cell used for purification of copper. Study it and answer the questions that follows.

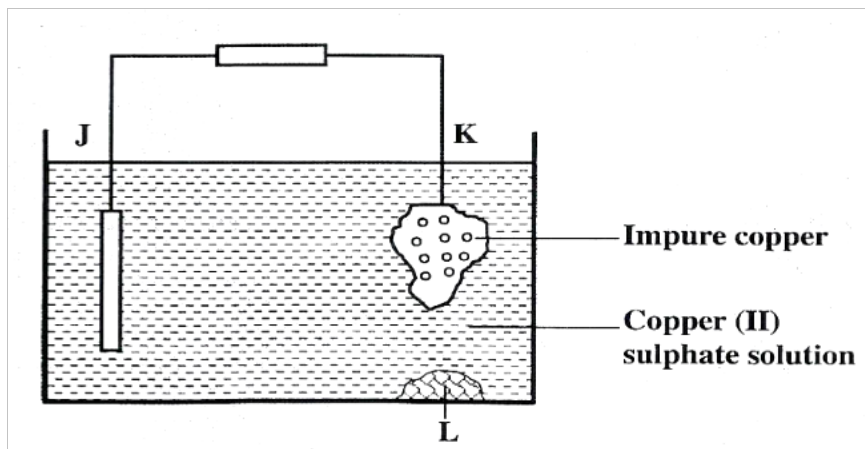

i) Identify the cathode (1 mk)

ii) Write the equation for the reaction at the anode

(1 mk)

iii) What name is given to L? (1 mk)

iv) A current of 0.6 A was passed Through the electrolyte for 2 hours.

Determine the amount of copper deposited

(Cu=63.5; 1 Faraday = 96,500 coulombs) (3 mks)

v) State two uses of copper metal (1 mk)

5. The set up below can be used to generate a gas without heating. This occurs when substance Mr reacts with solid N.

Substance M



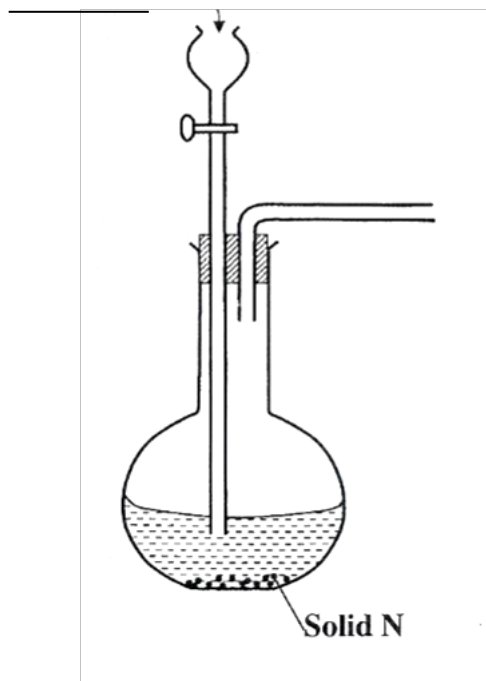

- a i) Complete the table below giving the names of substance M and solid N if the gasses generated are chlorine and sulphur (IV) oxide. (2 mks)

	Chlorine	Sulphur (IV) Oxide
Substance M		
Solid N		

- (ii) Complete the diagram above to show how a dry sample of sulphur (IV) oxide can be collected
- (b) Describe two chemical methods that can be used to test the presence of sulphur (IV) oxide. (3 mks)
- (c) Other than the manufacture of sulphuric (VI) acid, state two uses of sulphur (IV) oxide. (2 mks)
6. (a) Other than concentration, state two factors that determine the rate of a reaction. (2 mks)
- b) In an experiment to determine the rate of reaction, excess lumps of calcium carbonate were added to 2 M hydrochloric acid. The mass of calcium carbonate left was recorded after every 30 seconds. The results are shown in the table below

<b>Time (seconds)</b>	0	30	60	90	120	150	180	210
<b>Mass of calcium carbonate left (g)</b>	2.00	1.60	1.30	1.00	0.85	0.8	0.8	0.8

- i) Write the equation for the reaction that took place
- ii) On the grid provided, plot a graph of mass of calcium carbonate vertical axis Against time
- (iii) Determine the rate of reaction at the 105<sup>th</sup> second.

(3 mks)

- (c) Why does the curve level off after some time?

(1 mk)

- (d) On the same grid, sketch a curve for the same reaction using 4 M hydrochloric acid and label the curve R.

(2 mks)

- 7 (a) Naturally occurring magnesium consists of three isotopes. 78.6% <sup>24</sup>Mg; 10% <sup>25</sup>Mg and <sup>26</sup>Mg. Calculate to one decimal place, the relative atomic mass of magnesium.

(2 mks)

- (b) When magnesium burns in air, it forms a white solid and a grey-green solid. When a few drops of water are added to the mixture, a gas that turns red litmus paper blue is evolved.

Identify the

- (i) white solid. (1 mk)

- (ii) gas evolved and state its use.

- (I) Name of gas (1 mk)

- (II) Use of the gas. ;

(1 mk)

- (c) Two different samples of water (I and II) were tested with soap solution. Sample II was further subjected to two other processes before adding soap.

20 cm<sup>3</sup> of each sample of water was shaken with soap solution in a boiling tube until a permanent lather was obtained. The results are shown in the table below

Water sample	Volume of soap solution needed (cm <sup>3</sup> )	
	before boiling	after boiling
I	10	5
II	6	6
II after filtering	6	6
II after distilling	2	2

- (i) Identify the water sample that had temporary hardness. Explain your answer. (2 mks)
- (ii) Explain why the results for sample II are different after distilling but remain unchanged after filtering. (2 mks)
- (iii) State two disadvantages of using both water samples for domestic purposes. (2 mks)

## CHEMISTRY PAPER 233/2 K.C.S.E 2016 QUESTIONS

1. Use the information in the table below to answer the questions that follow, represent the actual symbols of the elements.

Element	Atomic number	Melting point °C

R	11	97.8
S	12	650.0
T	15	44.0
U	17	-102
V	18	-189
w	19	64.0

- a) Give a reason why the melting point of
- i) S is higher than that of R (2 mks)
  - ii) V is lower than that of U. (2 mks)
- b) How does the reactivity of W with chlorine compare with that of R with chlorine? (2 mks)
- c) Write an equation for the reaction between T and excess oxygen (1 mk)
- d) When 1.15 g of R was reacted with water 600cm<sup>3</sup> of gas was produced. Determine the relative atomic mass of R. (molar gas volume = 24000CM<sup>3</sup>) (3 mks)
- e) Give one use of element V (1 mk)

2. a) Describe the process by which nitrogen is obtained from air on a large scale (4mks)

b) Study the flow chart below and answer the questions that follow.

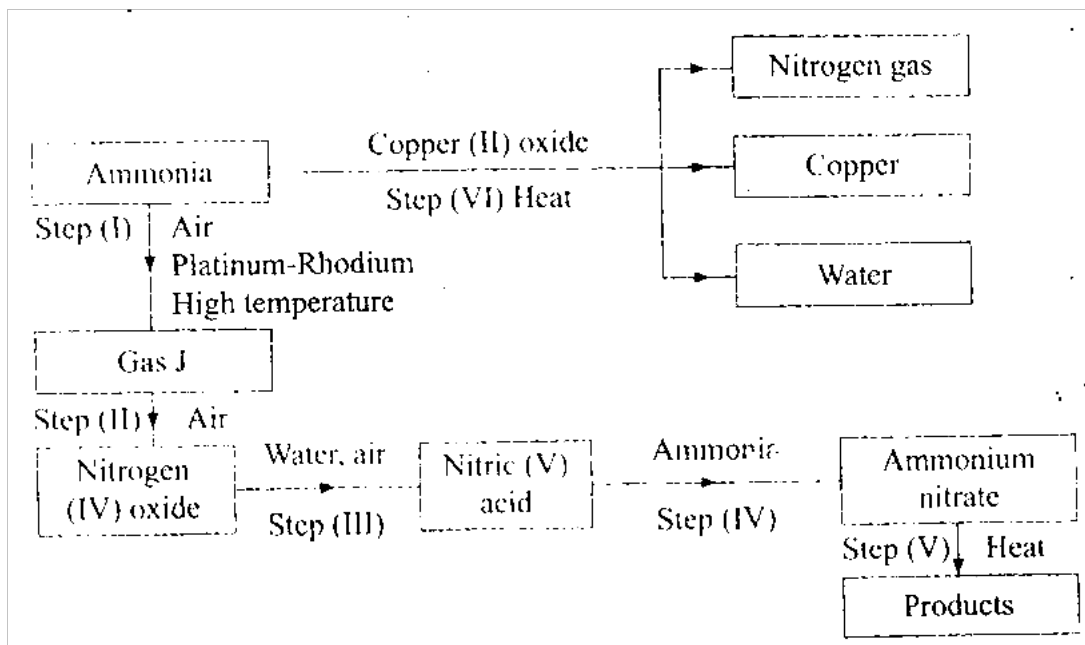

- (i) Identify gas J. (1mk)
- (ii) Using oxidation numbers show that ammonia is the reducing agent in step (VI) (2 mks)
- (iii) Write the equation for the reaction that occurs in step (V). (1 mk)
- (iv) Give two uses of ammonia nitrate. (2 mks)
- (c) The table below shows the observation made when aqueous ammonia was added to cation of elements E, F and G until in excess

Cation of	Addition of a few drop s of aqueous ammonia	adiiton of excess aqueous ammonia
E	white precipitate	insoluble
F	no precipitate	no precipitate
G	white precipitate	dissolves

- (i) Select the cation that is likely to be  $Zu^{2+}$  (1 mk)
- (ii) Given that the formula of the cation of element E is  $E^{2+}$  write the ionic equation for the reaction between  $E^{2+}$  (aq) and aqueous ammonia. (1 mk)

3. (a) Methanol is manufactured from carbon (IV) oxide and hydrogen gas according to the equation,



The reaction is carried out in the presence of a chromium catalyst at 700K and 300k pa. Under these conditions, equilibrium is reached when 2% of the carbon (IV) oxide is converted to methanol.

- (i) How does the rate of the forward reaction compare with that of the reverse reaction when 2% of the carbon (IV) oxide is converted to methanol? (1 mk)
- (ii) Explain how each of the following would affect the yield of methanol:
- I reduction in pressure (2 mks)
  - II using more efficient catalyst (2 mks)
- (iii) If the reaction is carried out at 500k and 300k pa, the percentage of carbon (IV) oxide converted to methanol is higher than 2%.
- I What is the sign of  $\Delta H$  for the reaction? Give a Reason (2 mks)
  - II Explain why in practice the reaction is carried out at 700K but not at 500K (2 mks)

- (b) Hydrogen peroxide decomposes according to the following equation:



In an experiment the rate of decomposition of hydrogen peroxide was found to be  $6.0 \times 10^{-8} \text{ mol dm}^{-3} \text{ s}^{-1}$

- (i) Calculate the number of moles per  $\text{dm}^3$  of hydrogen peroxide that has decomposed within the first 2 minutes. (2 mks)
- (ii) In another experiment, the rate of decomposition was found to be

$1.8 \times 10^{-7} \text{ moldm}^{-3}\text{s}^{-1}$ . The difference in the two rates could have been caused by addition of a catalyst. State giving reason, one other factor that may have caused the difference in the two rates of decomposition. (2

mks)

4. a) The set up below can be used to produce sodium hydroxide by electrolyzing brine

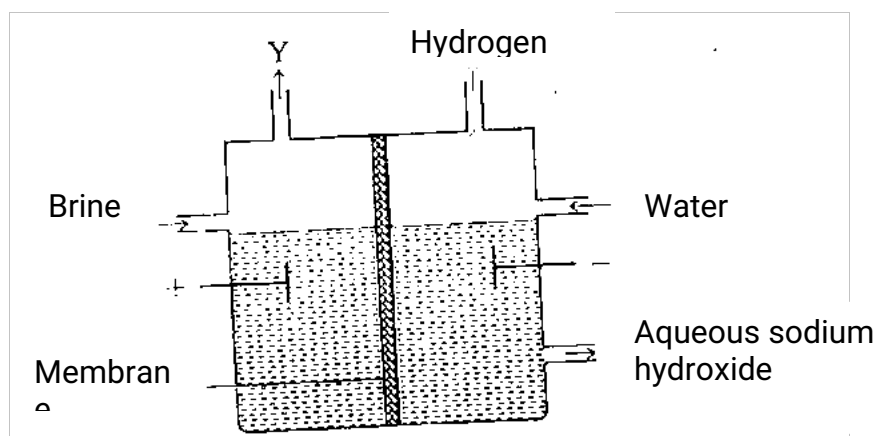

i) Identify gas y (1 mk)

ii) Describe how aqueous sodium hydroxide is formed in the above set up (2 mks)

iii) One of the uses of sodium hydroxide is in the manufacture of soaps. State one other use of sodium hydroxide (1 mk)

b) Study the information given below and answer the questions that follow

Half reactions	Electrode potential $E^{\ominus}/\text{V}$
$\text{D}^{2+}_{(\text{aq})} + \text{e} \longrightarrow \text{D}_{(\text{s})}$	0.13
$\text{E}^{+}_{(\text{aq})} + \text{e} \longrightarrow \text{E}_{(\text{s})}$	+0.80
$\text{F}^{3+} + \text{e} \longrightarrow \text{F}^{2+}_{(\text{aq})}$	+0.68
$\text{G}^{2+}_{(\text{aq})} + 2\text{e} \longrightarrow \text{G}_{(\text{s})}$	-2.87
$\text{H}^{2+}_{(\text{aq})} + 2\text{e} \longrightarrow \text{H}_{(\text{s})}$	+0.34
$\text{E}^{+}_{(\text{aq})} + \text{e} \longrightarrow \text{E}_{(\text{s})}$	-2.71

(i) Construct an electrochemical cell that will produce the largest e.m.f.

- (ii) Calculate the e.m.f. of the cell constructed in (i) above.
- (iii) Why is it not advisable to store a solution containing  $E^+$  ions in a container in of H?

5. The diagram below represents a set up of an electrolytic cell that can be used in the production of aluminium.

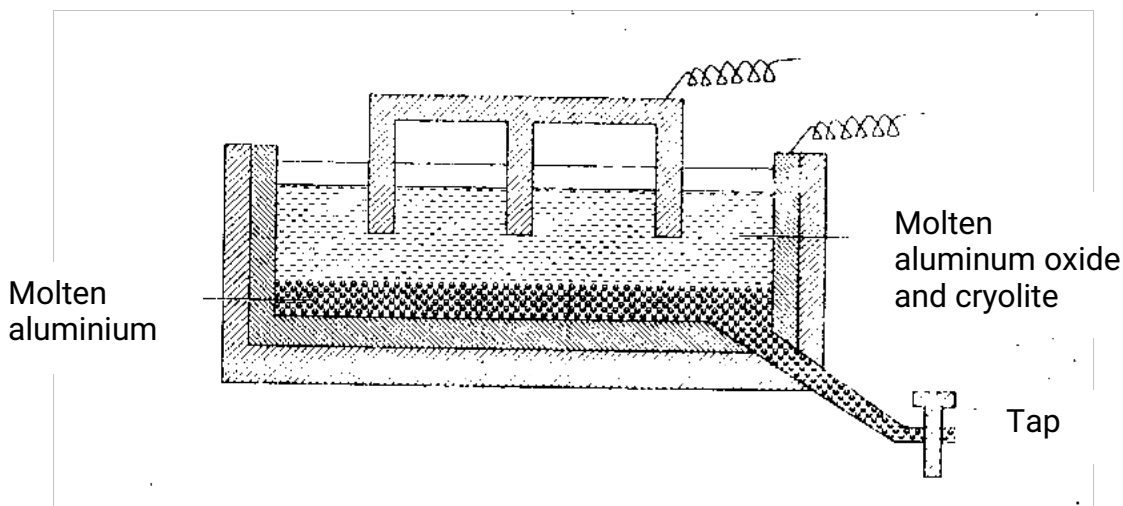

- (a) On the diagram, label the anode. (1 mk)
- (b) Write the equation for the reaction at the anode. (1 mk).
- (c) Give a reason why the electrolyte process is not carried out below  $950^{\circ}\text{C}$ . (1 mk)
- (d) Give a reason why the production of aluminium is not carried out using reduction process. (1 mk)
- (e) Give two reasons why only the aluminium ions are discharged (2 mks)
- (f) State two properties of duralumin that makes it suitable for use in aircraft industry. (2 mks)
- (g) Name two environmental effects caused by extraction of aluminium. (2 mks)

6. a) Draw the structural formula for all the isomers of  $\text{C}_2\text{H}_3\text{Cl}_3$  (2mks)

b) Describe two chemical tests that can be used to distinguish between ethene



- c) The following scheme represents various reactions starting with propan-1-ol. Use it to answer the questions that follow

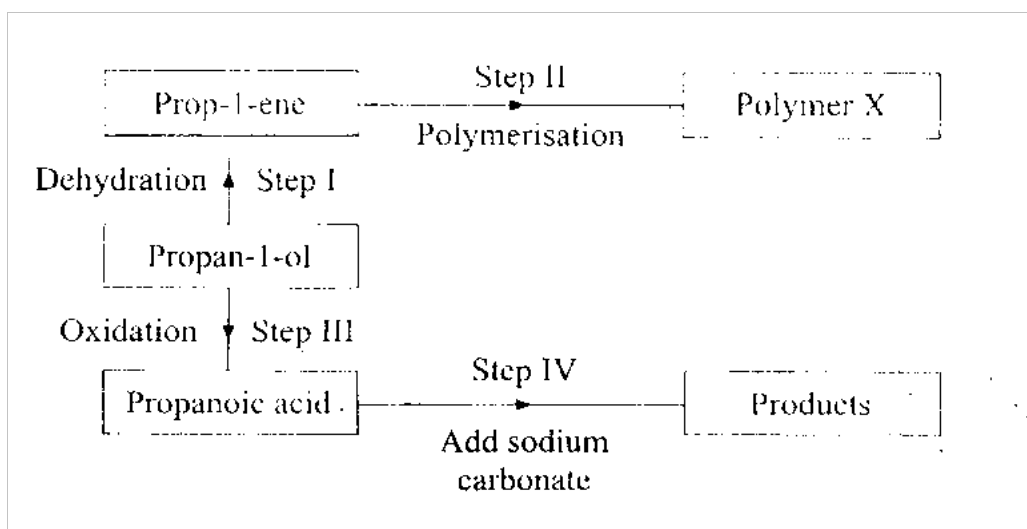

- i) Name one substance that can be used in step 1 (1 mk)
- ii) Give the general formula of X (1 mk)
- (iii) Write the equation for the reaction in Step IV.
- (iv) Calculate the mass of propan-1-ol which when burnt completely in air at room temperature and pressure would produce  $18\text{dm}^3$  of gas. (C = 12.0, O = 16.0, H = 1.0; molar gas volume =  $24\text{dm}^3$ ) (3 mks)
7. a) Write an equation to show the effects of heat on the nitrates of
- i) Potassium (1mk)
- ii) Silver (1 mk)
- b) The table below gives information about elements A<sub>1</sub>, A<sub>2</sub>, A<sub>3</sub> and A<sub>4</sub>.

Elements	Atomic Number	Atomic radius (nm)	Atomic radius (nm)
A1	3	0.134	0.074
A2	5	0.090	0.012
A3	13	0.143	0.050
A4	17	0.099	0,181

(i) In which period of the periodic table is element A ? Give a reason. (2 mks)

(ii) Explain why the atomic radius of:

I A1 is greater than that of A2 (2 mks)

II A1 is smaller than its ionic radius. (2 mks)

(iii) Select the element which is in the same group as A3. (1 mk).

(iv) Using Dots (.) and crosses (x) to outermost electrons, draw a diagram to show the bonding in the compound formed when A1 reacts with A4. (2 mks)



*'an investment of knowledge pays*

The following KASNEB notes are available;

 **ATD**

 **CPA**

 **CS**

 **CIFA**

*Call Mdm.Mariam;0746711892 to acquire them*

