

BIOLOGY PP1 QUESTIONS 1996-2016

WhatsApp/Sms/Call **Sir Obiero Amos** @
0706 851 439 for Marking Schemes
2006-2016

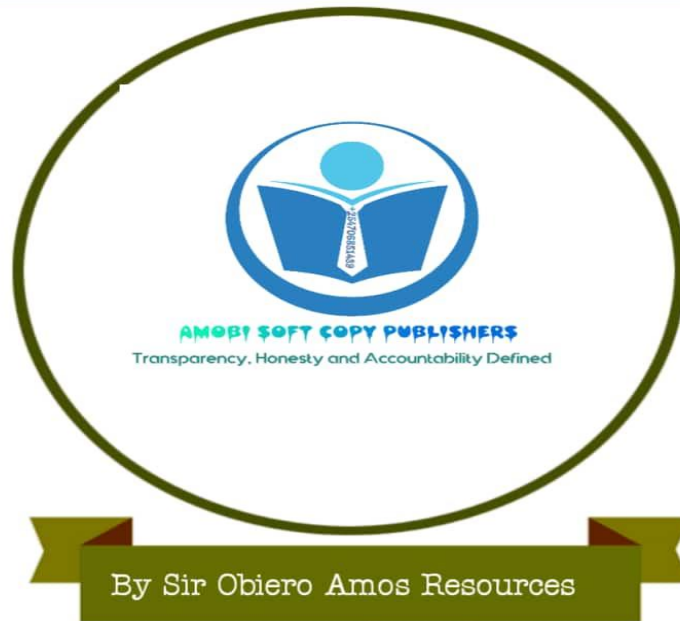

WhatsApp /Sms/Call
0706851439

MAKE WORK EASIER WITH AMOBI SOFT
COPY PUBLISHERS. SOLUTIONS TO ALL
YOUR SOFTCOPY RESOURCES

FOR A VARIETY OF REVISION KITS
WhatsApp/Sms/Call
By Sir Obiero Resources 0706851439

BIOLOGY
K.C.S.E PAPER 231/1 1995
QUESTIONS

SECTION A (20 MARKS)

Answer all questions in this section in spaces provided

1. Motor vehicles move, use energy and produce carbon dioxide and water. Similar characteristics occur in living organisms yet motor vehicles are not classified as living
(3 mks)
2. Name the organelle that performs each of the following functions in a cell
(2 mks)
Proteins synthesis
Transport of cell secretions
3. State two ways in which some fungi are harmful to man
(2 mks)
4. Explain what would happen to red blood cells if they are placed in a concentrated salt solution
(2 mks)
5. State the role of light photosynthesis
(2 mks)
6. The diagram below represents a fern

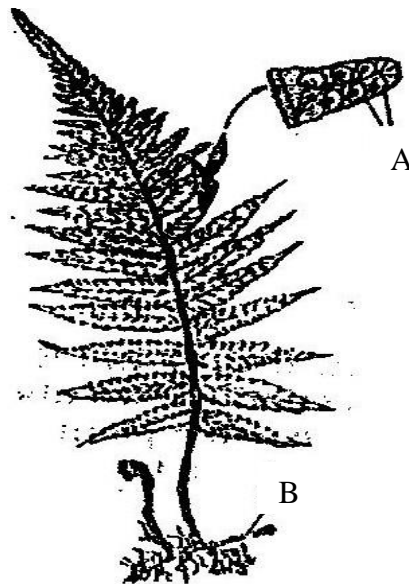

Name

(a) The parts labeled A and B

(2 mks)

(b) The division to which the plant belongs (1 mk)

7. Complete the table below on mineral nutrition in plants (3 mks)

Mineral element	Function	Deficiency symptoms
	Synthesis of proteins and protoplasm	Stunted growth and yellowing of leaves
Calcium		
	Forms part of chlorophyll	Yellowing of leaves

8. Explain why Larmacks theory of evolution is not accepted by biologists today (2 mks)

9. name a disorder of human blood that is caused by mutation (1 mk)

SECTION B (40 MARKS)

10. An experiment was carried out to investigate the rate of reaction shown below



For the products fructose and glucose to be formed, it was found that substance K was to be added and the temperature maintained at 37°C. When another substance L was added, the reaction slowed down and eventually stopped.

(a) Suggest the identify of substances K and L (2 mks)

(b) Other than temperature state three ways by which the rate of reaction could be increased (3 mks)

(c) Explain how substance L slowed down the reaction (2 mks)

11. The diagram below represents a transverse section of a young stem

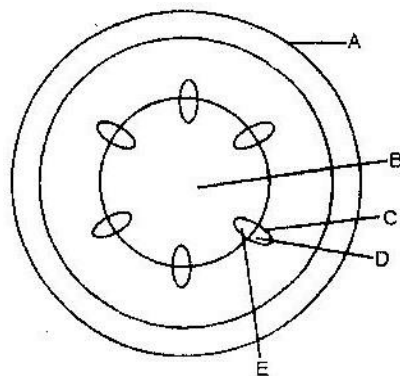

(a) Name the parts labeled A and B (2 mks)

(b) State the functions of the parts labeled C, D and E (4 mks)

- (c) List three differences between the section shown above and one that would be obtained from the root of the same plant (3 mks)

12. The diagram below shows an experimental soil up to investigate an aspect of germination

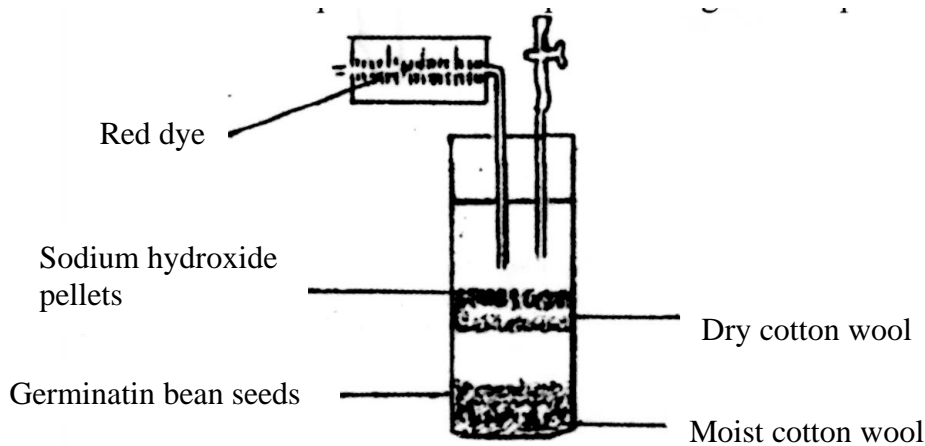

- (a) Why are sodium hydroxide pellets used in this experiment? (1 mk)
- (b) Why is moist cotton wool used in this experiment? (1 mk)
- (c) (i) By means of an arrow, indicate on the diagram the direction in which red dye would move during the experiment. (1 mk)
(ii) Give reasons for your answer in (c) (i) above (3 mks)

13. The chart below shows a feeding relationship in a certain ecosystem

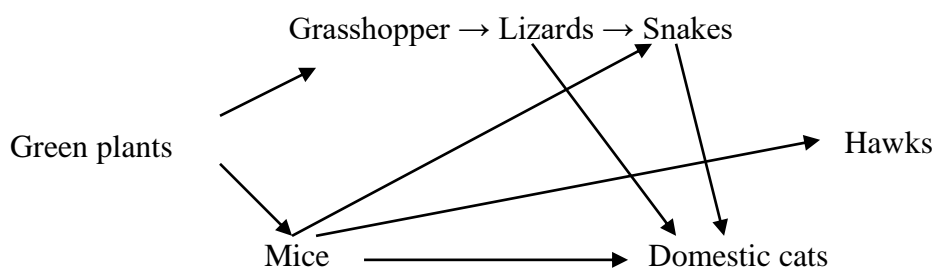

- (a) Construct two food chains ending with a tertiary consumer in each case (2 mks)
- (b) Which organism has the largest variety of predators in the food web? (1 mk)
- (c) Name secondary consumers in food web (2 mks)
- (d) Suggest three ways in which the ecosystem would be affected in there

was a prolonged drought.

14. The diagram below represents growing seedlings which were subjected to unilateral light at the beginning of an experiment

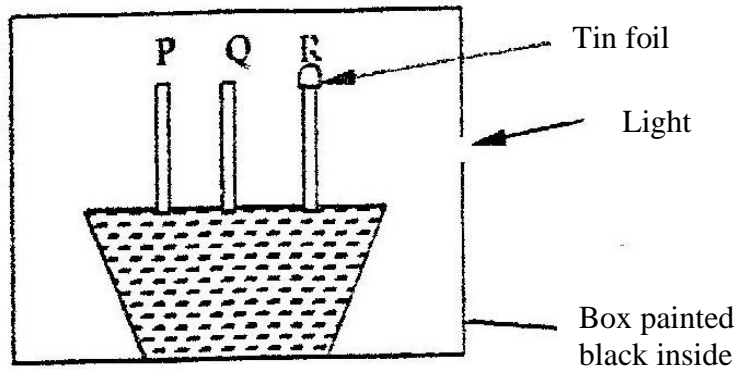

- (a) (i) State the results of P,Q and R after 5 days? (5 mks)
- (ii) Account for your answer in (a) (i) above (3 mks)
- (b) If the tin foil were removed from the tip of the seedling R, what results would be observed after 2 days? (1 mk)
- (c) State the expected results after 3 days if the box were removed (1 mk)

SECTION C (40 Marks)

Answer questions 15 (compulsory) in the spaces provided

15. The graph below represents the increase in the number of yeast cells over a period of 48 minute

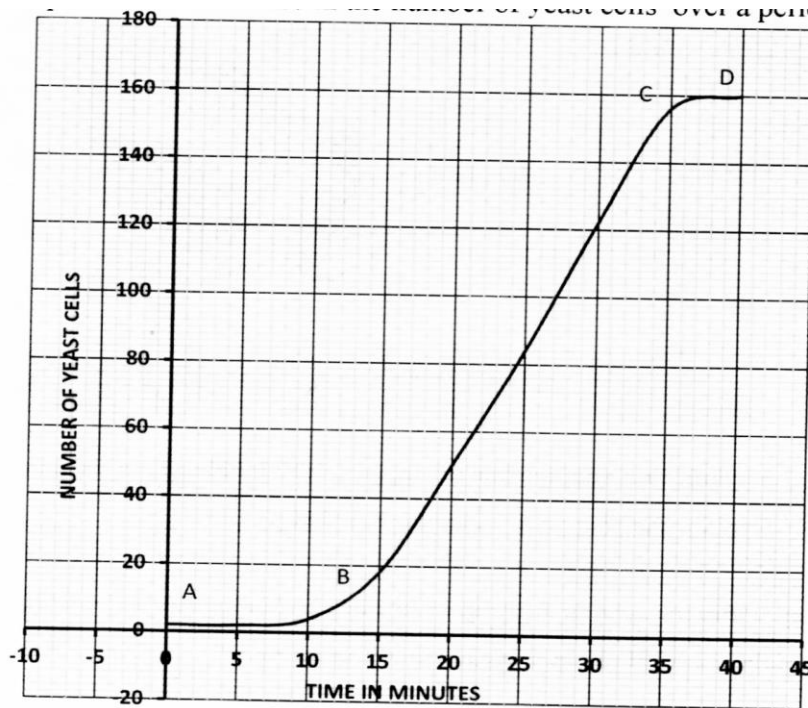

- (a) Name the type of curve shown (1 mk)
- (b) Determine the number of yeast cells after 26 minutes (1 mk)
- (c) Work out the rate of cell division between 24 and 28 minutes (2 mks)
- (d) After how long was the population of yeast cells 128? (1 mk)
- (e) Name the phase of the curve labeled
- (i) A to B
 - (ii) B to C
- (f) Give reasons for the shape of the graph between points C and D (3 mks)
- (g) State five factors, which would cause human population growth to assume the shape of the graph curve between points B and C (5 mks)
- (h) Describe how the quadrat method can be used to estimate the population of various species of plants in a given habitat (5 mks)
16. (a) Describe how insect pollinated flowers are adapted to pollination
- (b) Describe the role of each of the following hormones in the human menstrual cycle
- (i) Oestrogen

- (ii) Progesterone
- (iii) Luteinising hormone (9 mks)

17. Describe how excretion takes place in

- (i) Mammalian Kidneys
- (ii) Green plants (5 mks)

BIOLOGY
K.C.S.E PAPER 231/1 1995
QUESTIONS

1. State the function of Deoxyribonucleic acid (DNA) molecule (1mk)
2. State two ways by which acquired Immune deficiency syndrome (A.I.D.S) Virus is transmitted. (2 mks)
3. When is glycogen which is stored in the liver converted into glucose and released into the blood (1 mk)
4. Name the disease in humans that is caused by lack of vitamin C (1 mk)
5. An organism with an exoskeleton, segmented body, two pairs of legs per segment, a pair of eyes and a pair short antennae belongs to the phylum (1 mk)
6. What are two organisms considered to belong to the same species (2 mks)
7. (a) state the role of light in the process of photosynthesis (1 mk)
(b) Name one end product of dark reaction in photosynthesis (1 mk)

8. State two functions of cell sap (2 mks)

9. State three characteristics that ensure cross – pollination takes place in flowering plants (3 mks)

10. A student set up an experiment as shown in the diagrams below

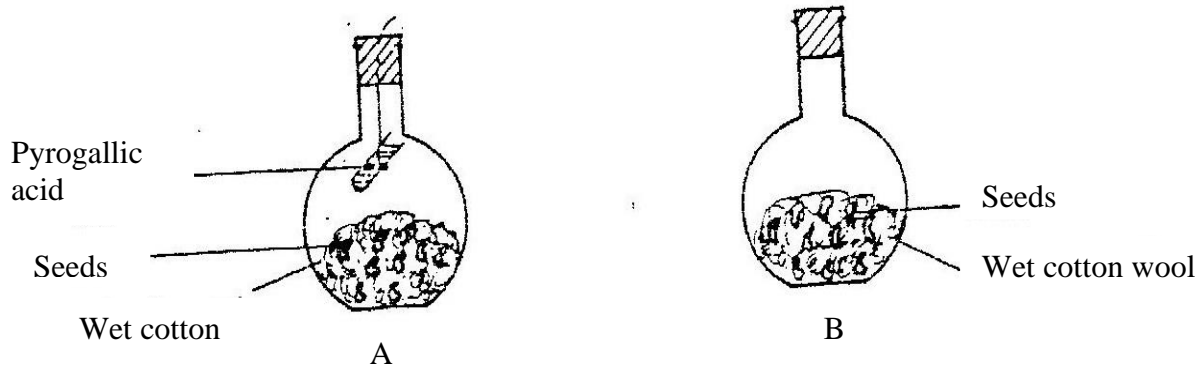

The set up was at room temperature for a week

(a) What was the aim of the experiment? (1 mk)

(b) What would be the expected results at the end of the experiment (2 mks)

11. Give a reason why it is only mutation in genes of gametes that can influence evolution (1 mk)

12. Give a reason why it is necessary for frogs to lay many eggs (1 mk)

13. The diagram below shows a set – up that was used to demonstrate Fermentation

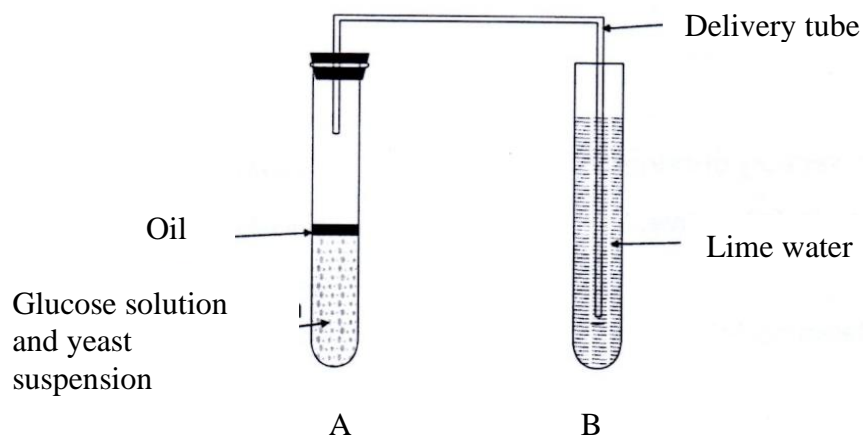

Glucose solution was boiled and oil added on top of it. The glucose solution was then allowed to cool before suspension.

- (a) Why was the glucose solution boiled before adding the yeast Suspension? (1 mk)
- (b) What was the importance of cooling the glucose solution before adding the yeast suspension? (1 mk)
- (c) What was the use of oil in the experiment? (1 mk)
- (d) What observation would be made in test tube B at the end of the experiment? (1 mk)
- (e) Suggest a control for this experiment (1mk)
14. (a) Describe the path taken by carbon dioxide released from the tissue of an insect to the atmosphere (3 mks)
- (b) Name two structures used for gaseous exchange in plants (2 mks)
15. To estimate the population size of crabs in a certain lagoon, traps were laid at random. 400 crabs were caught, marked and released back into the lagoon. Four days later, traps were laid again and crabs were caught. Out of the 374 crabs, 80 were found to be marked.
- (a) calculate the population size of the crabs in the lagoon using the formula below
- $$N = \frac{n \times M}{m}$$
- Where N = Total population of crabs in the lagoon
n = Total number of crabs in the second catch
M = Number of marked crabs during the first catch
m = Number of marked crabs in the second catch (2 mks)
- (b) State two assumptions that were made during the investigation (2 mks)
- (c) What is the name given to this method of estimating the population size (1 mk)
16. A shoot of seedling exposed to light on one side bends towards the source of light as it grows

(a) Name the response exhibited by the shoot of the seedling (1 mk)

(b) Explain how the bending towards the source of light occurs (3 mks)

17. (a) How may excessive bleeding results in death? (4 mks)

(b) Name the process by which the human body naturally stops Bleeding? (1 mk)

(c) How can low blood volume be brought back to normal (3mks)

18. In an experiment black mice were crossed and the offspring were black and brown. The gene for black colour is dominant over that of brown colour. Using letter B to represent the gene for black colour and b to represent the gene for brown colour

(a) Work out the genotypes of the F₁ generation (4 mks)

(b) What is the phenotypic ratio of the offspring (1 mk)

19. The diagram below represents the pathways of water from the soil into the plant.

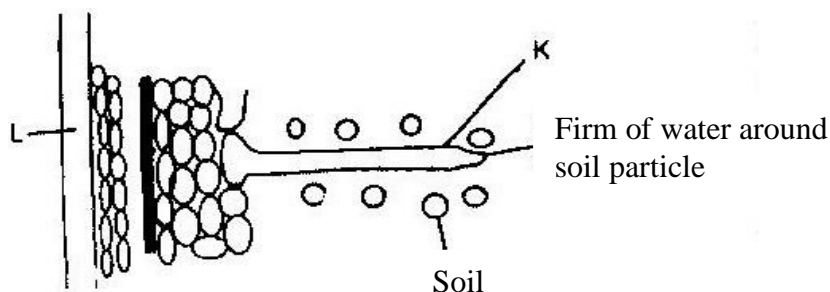

(a) Name the structures labeled K and L. (2 mks)

(b) Explain how water from the soil reaches the structure labeled L. (5 mks)

(c) Name the process by which mineral salts enter into the plant (1 mk)

20. A culture of bacteria was incubated in nutrient agar at 35⁰C. Samples were taken at intervals in order to estimate the number of bacteria in the population. The data obtained is shown in the graph below.

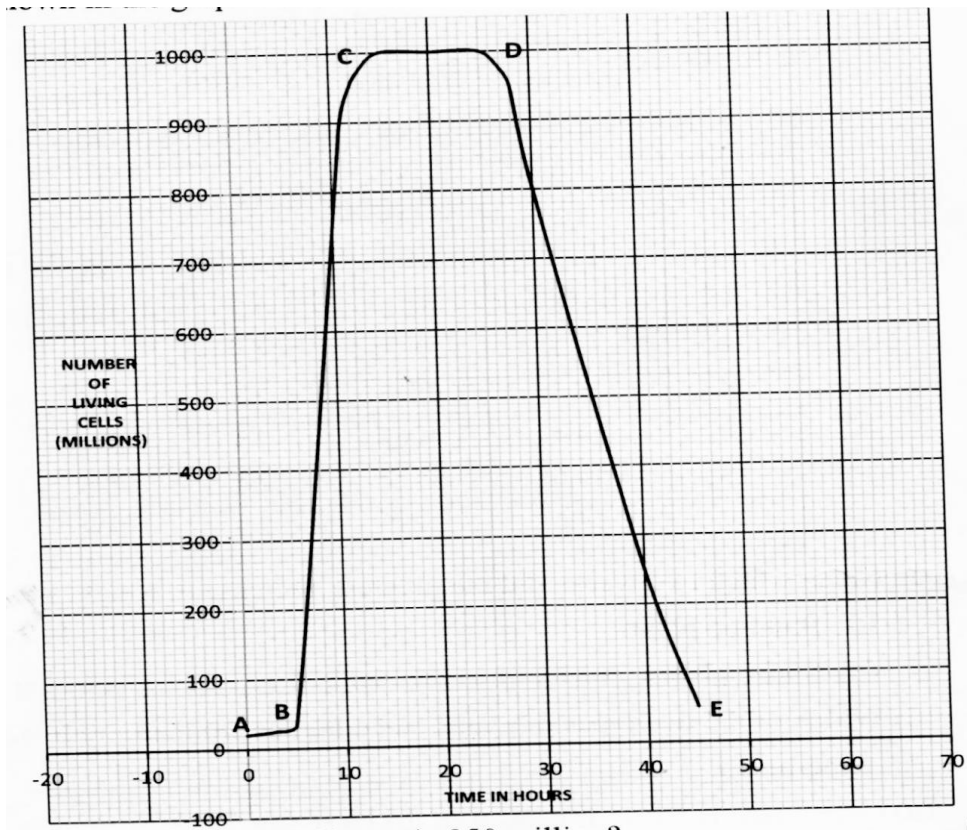

- (a) When was the pollution of bacteria 350 million
- (b) Account for the shape of the graph between
- A and B
 - B and C
 - C and D
- (c) Give three reasons for the shape of the curve between D and E
- (d) (i) Suggest what would happen to the population of the bacteria if the temperature was lowered to 0° after incubating for 12 hours.
- (ii) Give a reason for your answer in (d) (i) above
- (e) Give three reasons why it is important to control human population growth rate in Kenya?

21. Explain how the mammalian skin is adapted to perform its functions (20 mks)

22. Describe how new plants arise by asexual reproduction

(20 mks)

BIOLOGY
K.C.S.E PAPER 231/1 1997
QUESTIONS

SECTION A

Answer all the questions in this section in the spaces provided

1. State the functions of the following cell organelles
 - (a) Golgi apparatus
 - (b) Ribosomes

2. A student caught an animal which had the following characteristics:
Body divide into two parts
Simple eyes

Eight legs

The animal belong to the class

3. What are the three end products of anaerobic respiration in plants
4. state two ways in which xylem vessels are adapted to their function
5. In an accident a victim suffered brain injury. Consequently he had loss of memory. Which part of the brain was damaged?
6. Oil can be applied on the stagnant water to control the spread of malaria.
 - (a) How does this practice control the spread of malaria?
 - (b) Give a reason why this practice should be discouraged
7. State three structural differences between biceps muscles of the gut.

Biceps	Gut Muscles
Striated	Unstriated
Multinucleated	Uninucleated
Long fibres	Short fibres
Cylindrical	Spindle shaped

8. A person was found to pass out large volumes of dilute urine frequently.
Name the
 - (a) Disease the person was suffering from
 - (b) Hormone that was deficient
9. state three pieces of evidence that support the theory of evolution
10. Name a disease caused by lack of each of the following in human diet.
Vitamin D
Iodine

SECTION B (40 MARKS)

11. The following below represents a feeding relationship in an ecosystem

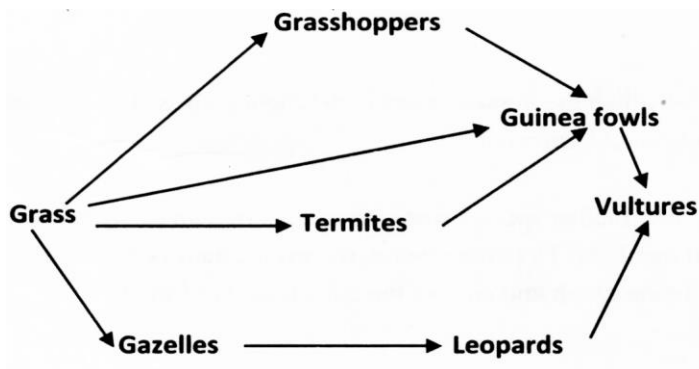

- Write down the food chains in which the guinea fowls are secondary consumers
- What would be the short term effects on the ecosystem if lions invaded the area?
- Name the organism through which energy from the sun enters the food web.

12. A person was able to read a book clearly at arm's length but at normal reading distance.

- State the defect the person suffered from?
- Why was he unable to read book clearly at normal distance
- How can the defect be corrected?

13. An experiment was carried out to determine the rate of transpiration in three plants A, B and C. Plants, A and B belonged to different species while plants B and C belonged to the same species. Plant C had all its leaves removed. The three plants were of similar size and were exposed to the same environment conditions. The results are as shown below in the graphs below.

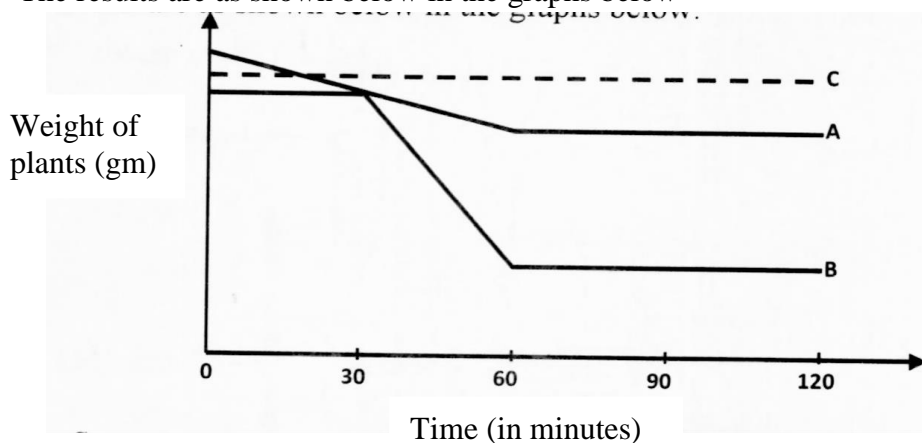

- Suggest possible environment conditions under which the experiment was carried out between 30 and 60 minutes
- Account for the results obtained for plant C
- Suggest the habitat for plant A and B. Give reasons for your answer.

Habitat for plant A
 Habitat for plant B

14. The diagram below represents a simplified nitrogen cycle.

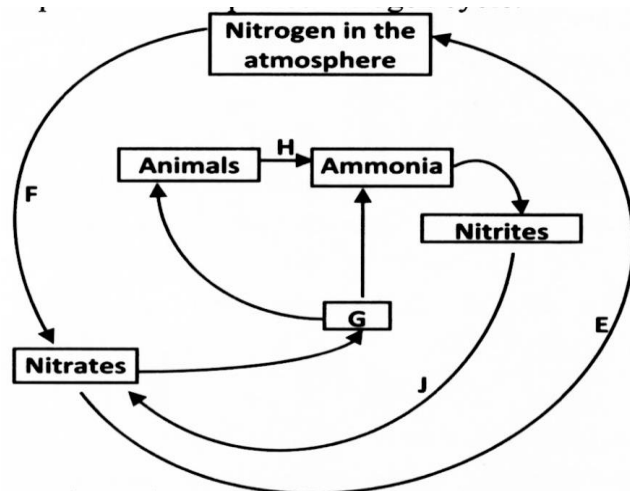

- (a) Name the organisms that cause process E and J
- (b) Name the process represented by F and H.
- (c) Name the group of organism represented by G

15. The equation below represent a metabolic that occurs in the mammalian live
 Amino acids → Organic compounds + urea

- (a) Name the process.
- (b) What is the importance of the process to the mammal?
- (c) What is the source of amino acids in this process
- (d) What is the difference between essential and nonessential amino acids?

16. In a breeding experiment, plants with red flowers were crossed. The produced 123 plants with red flowers and 41 with white flowers

- (a) Identify the recessive character
 Give a reason
- (b) What was the genotype of the parent plants that gave rise to the plants with a red and white flowers?

17. Figures 1 and 2 below represent reproductive organ of plants and an animal respectively.

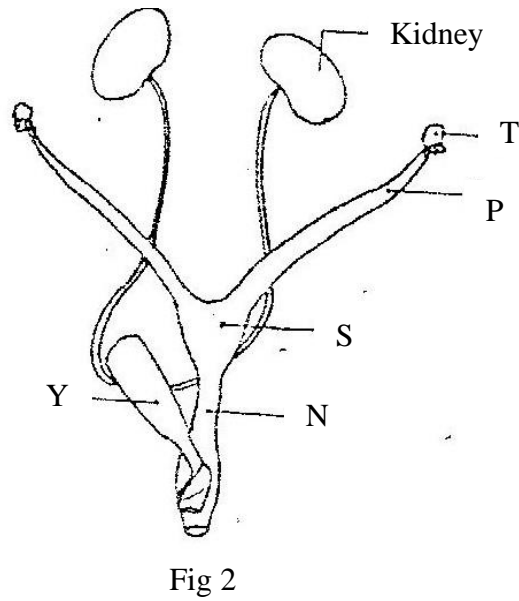
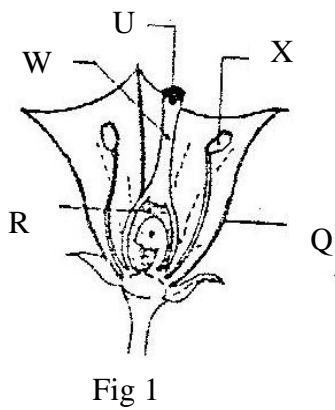

- (a) Which letters in figures 1 and 2 represents the organs that produce female gametes?
 Figure 1
 Figure 2
- (b) What is the function of the structure labeled S?
- (c) Name the structure labeled W
- (d) Which letters in figures 1 and 2 represents the structures where fertilization takes place
- (e) Which letter in figure 1 represents the structure where male gametes are produced?

SECTION C (40 marks)

18. An experiment was carried out to determine the growth rates of bamboo and a variety of maize plants in two adjacent plots. The average height and average dry weight of plants from the two populations were determined over a period of twenty weeks. The data is as shown in the table below.

	Bamboo		Maize	
Age in weeks	Average height (Metres)	Average weight (Grams)	Average height (Metres)	Average weight (Grams)
2	1.3	52	0.3	20
4	4.0	182	0.5	29
6	8.2	445	0.8	57
8	12.1	682	1.2	78
10	13.9	801	1.7	172
12	14.1	957	1.9	420
14	14.3	1025	2.1	704
16	14.4	1062	2.1	895
18	14.6	1127	2.1	926
20	14.6	1229	2.1	908

(a) Between which two weeks did the greatest increase in weight occur in

(b) Bamboo plants

(ii) Maize plants

(b) (i) Which of the two types of plants had a higher productivity by the end of the experiment

(ii) Give a reason for your answer in (b) (i) above

(c) Between weeks 14 and 18, the average height of the maize plants remained constant while average dry weight increased.

Explain this observation

(d) Suggest how the change in the average dry weight bamboo and maize Plants would have been at week 22 if the experiment was continued.

(e) Why was it appropriate for this experiment to use

(i) Dry weight instead of fresh weight

(ii) Weight and height

(f) Describe how the average height and weight of the plants were determined in this experiment.

Average height

Average dry Weight

(g) Give a reason why secondary thickening does not occur in bamboo and maize plants

19. (a) What is parasitism?

(b) Describe how the tapeworm is adapted to a parasitic mode of life

20. (a) What is meant by the term digestion?

(b) Describe how the mammalian small intestine is adapted to its function

BIOLOGY
K.C.S.E PAPER 231/1 1998
QUESTIONS

1. Why are people with blood group O universal donors?
2. State one effect of magnesium deficiency in green plants
3. Which organelle would be abundant in:
Skeletal muscle cell
Palisade cell
4. Why are gills in fish highly vascularized?
5. What is the relationship between leguminous plants and bacteria found in their root nodules?
6. In an experiment it was found that when maggots are exposed to light they move to dark areas.
 - (a) Name the type of response exhibited by the maggots
 - (b) Name the advantages of the response to the maggots
7. The diagram below represents a mammalian bone



- (a) Name the bone
 - (b) Name the type of the joint formed by the bone at its anterior end with the adjacent bone
8. A flower was found to have the following characteristics:
Inconspicuous petals
Long feathery stigma
Small, light pollen grains
 - (a) What is the likely agent of pollination of the flower
 - (b) What is the significance of the long feathery stigma in the flower?

9. What makes young herbaceous plant remain upright?
10. Give two reasons why primary productivity in an aquatic ecosystem decreases with depth.
11. State two ways by which the human immuno deficiency (H.I.V) is transmitted other than through sexual intercourse?
12. In a family with four children, three were found to have normal skin pigmentation while one was an albino.

Using letter A to represent gene for normal skin pigmentation and a to represent the gene for albinism,

- (a) What are the genotypes of the parents?
 - (b) Work out the genotype of
 - (i) Normal pigmentation
 - (ii) The albino child
 Genotype of normal pigmented children
 - (c) What is the probability that the fifth child will be an albino?
13. (a) List four differences between meiosis and mitosis
 - (b) Which sex chromosomes are found in human?
 - Sperm cell?
 - Ova?
 14. In an experiment to investigate a factor affecting photosynthesis, a leaf of a potted plant which had been kept in the dark overnight was covered with aluminum foil as shown in the diagram below

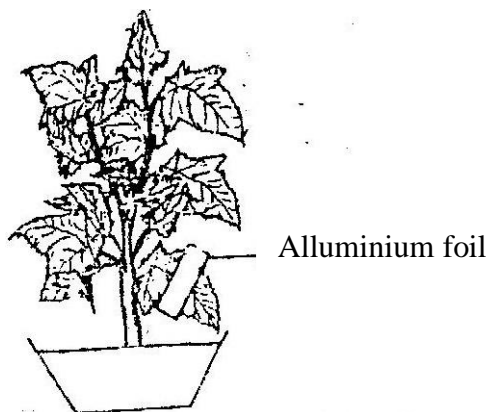

The set up was kept in sunlight for three hours after which a food test was carried out on the leaf.

- (a) Which factor was being investigated in the experiment?
- (b) What food test was carried out?
- (c) (i) State the results of the food test
(ii) Account for the results in c (i) above
- (d) Why was it necessary to keep the plant in darkness; before the experiment?

15. The herbivorous mammalian species were introduced into an ecosystem at the same time and in equal numbers. The graph below represents their populations during the first seven years. Study the graph and answer the questions that follow.

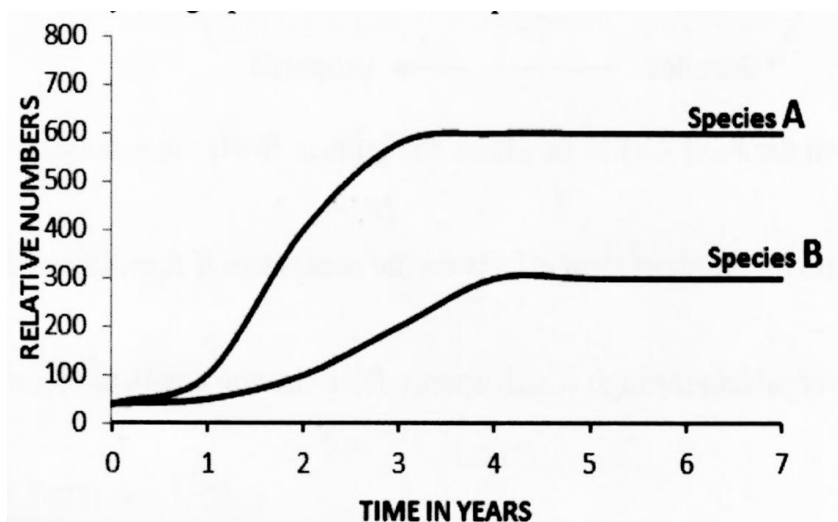

- (a) (i) Which species has a better competitive ability?
(ii) Give reason for your answer
- (b) Account for the shape of the curve species A between
 - (i) One year and three years
 - (ii) Three years and seven years
- (c) A natural predator for species A was introduced into the ecosystem. With a reason state how the population of each species would be affected.

16. A student placed a drop of pond water in a cavity slide and observed it under the microscope. The student observed many fast moving organisms, one of which is represented in the diagram below.

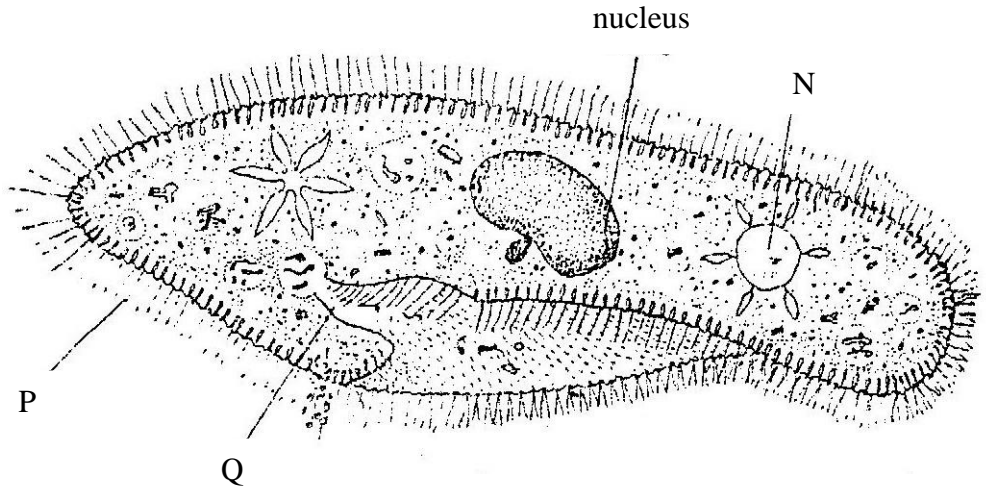

- (a) (i) Name the phylum to which the organism belongs
- (ii) Give a reason for your answer in (a) (i) above
- (b) Name the structures labeled N, P and Q.
- (c) State two observable features that enable the organism to move fast.

17. The diagram below represents a nerve cell.

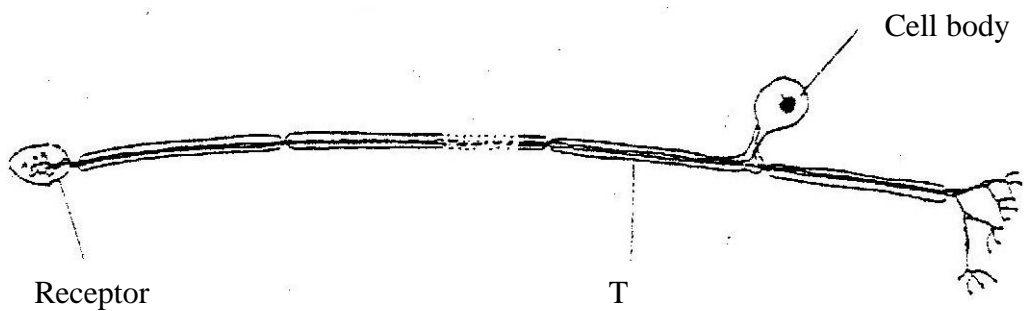

- (a) (i) Identify the nerve cell.
- (ii) Give a reason your answer in (a) (i) above
- (b) Name the structure labeled T
- (c) Using an arrow indicate on the diagram the direction of movement of an

impulse in the cell.

18. A hungry person had a meal, after which the concentration of glucose and amino acids in the blood were determined. This was measured hourly as the blood passed through the hepatic portal vein and the iliac vein in the leg. The results were as shown in the table below.

Time (Hrs)	Concentration of contents in hepatic portal vein (mg/100ml)	Concentration of contents in the iliac vein of the leg (mg/100ml)		
	Glucose	Amino acids	Glucose	Amino Acids
0	85	1.0	85	1.0
1	85	1.0	85	1.0
2	140	1.0	125	1.0
3	130	1.5	110	1.5
4	110	1.5	90	3.0
5	90	3.0	90	2.0
6	90	2.0	90	1.0
7	90	1.0	90	1.0

- (a) Using the same axes draw graphs of concentration of glucose in the hepatic portal vein and the iliac vein in the leg against time
- (b) Account for the concentration of glucose in the hepatic vein from:
- 0/1 hour
 - 1-2 hour
 - 2- 4 hours
 - 5 – 7 hours
- (c) Account for the difference in the concentration of glucose in hepatic portal vein and the iliac vein between 2 and 4 hours.
- (d) Using the data provided in the table explain why the concentration of amino acids in the hepatic portal vein took longer to increase.

19. Discuss the various evidences, which show that evolution has taken place.

20. Explain how the mammalian intestines are adapted to perform their function.

BIOLOGY
K.C.S.E PAPER 231/1 1999
QUESTIONS

SECTION A

1. Name two processes that bring about the translocation of manufactured food
2. Give two reasons why accumulation of lactic acid during vigorous exercise leads to an increase in heartbeat.
3. Explain why sexual reproduction is important in organisms
4. State two advantages of natural selection to organisms
5. Suggest three reasons why green plants are included in a fish aquarium.
6. State three ways by which plants compensate for lack of ability to move from one place to another.
7. An investigation plants with red flowers were crossed with plants with white flowers.
All the plants in the F1 generation had pink flowers.
 - a) Give a reason for the appearance of pink flowers in the F1 generation.
 - b) If the plants the F1 generation were selfed, state the phenotypic ratio of the F2 generation.
8. State two disadvantages of self-pollination.

SECTION B (40 MARKS)

9. The diagram below shows surface view of a human brain.

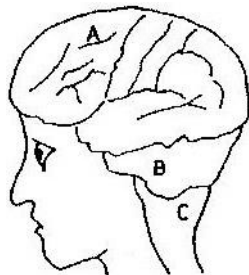

a) Name the parts labeled B and C.

b) State three functions of the part labelled A

c) State what would happen if the part labeled B was damaged.

10. Below is a list of organisms, which belong to classes Insecta, Myriapoda and Archnida: Tick, centipede, praying mantis, tsetse fly, millipede and spider.

Place the organisms in their respective classes in the table below.

Give reason in each case.

Classes	Organisms	Reasons
Insecta		
Myriapoda		
Arachnida		

11. Give reasons for each of the following:

a) Constant body temperature is maintained in mammals.

b) Low blood sugar level is harmful to the body.

12. A student set up an experiment as shown in the diagram below.

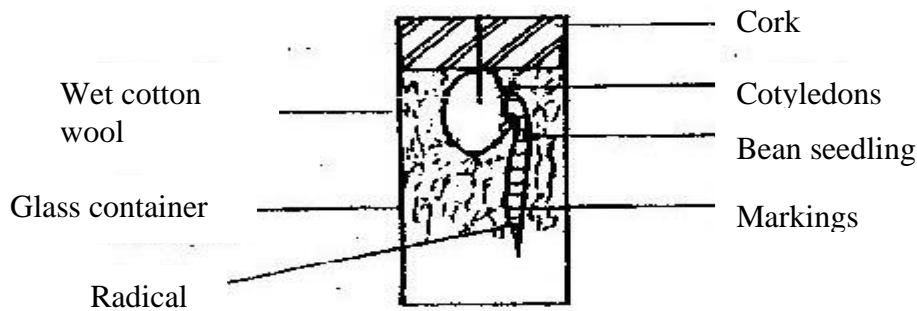

At the start

a) i) What is being investigated in the experiment?

ii) On the diagram below indicate the expected results after three days.



- iii) Why was it necessary to have wet cotton wool in the container?
- b) What is the role of the following to a germinating seed/
- i) Oxygen
- ii) Cotyledons.
13. a) Distinguish between a community and population.
- b) Describe how population of grasshoppers in a given area can be estimated.
14. The photograph below represents a blood smear obtained from a person suffering from a certain disease.

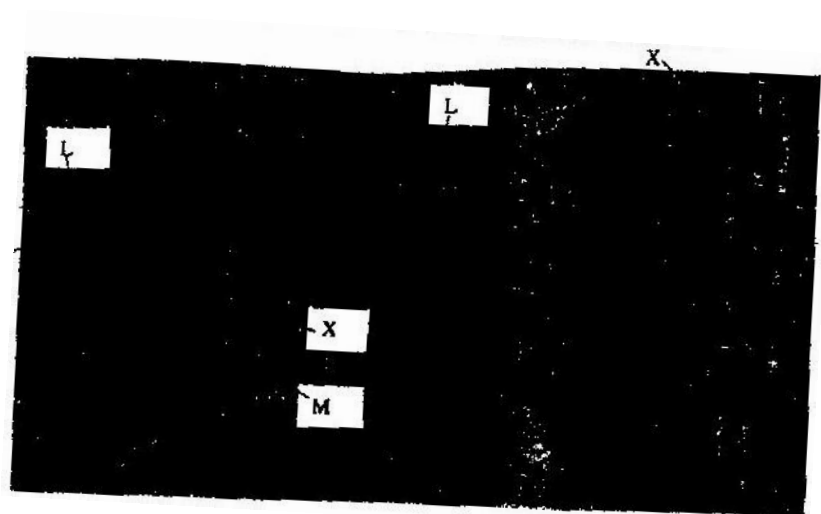

- a) Name the structure labeled X.
- b) i) Name the structure labeled L
- ii) State the function of the source labeled M
- c) What disease was the person suffering from?
- d) List three ways by which micro-organisms enter the human body.

SECTION C (40 MARKS)

15. An experiment was carried out to investigate haemolysis of human red blood cells. The red blood cells were placed in different concentrations of sodium chloride solution. The percentage of haemolysed cells was determined. The results were as shown in the table below.

Salt concentration g/100cm ³ (%)	0.33	0.36	0.38	0.39	0.42	0.44	0.48
Red blood cells	100	91	82	69	30	15	0

Haemolysed (%)							
----------------	--	--	--	--	--	--	--

- a) i) On the grid provided, plot a graph of haemolysed red blood cells against salt concentration.
- ii) at what concentration of salt solution was the proportion of haemolysed cells equal to non-haemolysed cells?
- iii) State the percentage of cells haemolysed at salt concentration of 0.45%
- b) Account for the results obtained at:
- i) 0.33 percent salt concentration.
- ii) 0.48 percent salt concentration.
- c) What would happen to the red blood cells if they were placed in 0.50 percent salt solution?
- d) Explain what would happen to onion epidermal cells if they were placed in distilled water.
16. Describe the:
- a) Process of inhalation in mammals.
- b) Mechanisms of opening and closing of stomata in plants.
17. Explain how the various activities of man have caused pollution of air.

BIOLOGY
K.C.S.E PAPER 231/1 2000
QUESTIONS

1. What is the function of the following cells in the retina of human eye ? Cones
2. Give a reason why two species in ecosystems cannot occupy the same niche.
3. State two ways in which some fungi are beneficial to humans
4. State two ways in which some fungi are beneficial to humans.
5. State the importance of osmo-regulation in organisms
6. Give a reason why lumbar vertebrae have long and broad transverse process
7. Give reason why each of the following is important in the study of evolution:
 - a) Fossils records
 - b) Comparative anatomy.
8. Why is oxygen important in the process of active transport in cells?
9. State two advantages of metamorphosis to the life of insects.
10. Explain how birds of prey are adapted to obtaining their food.

SECTION B

11. The diagram below represents a section of a leaf.

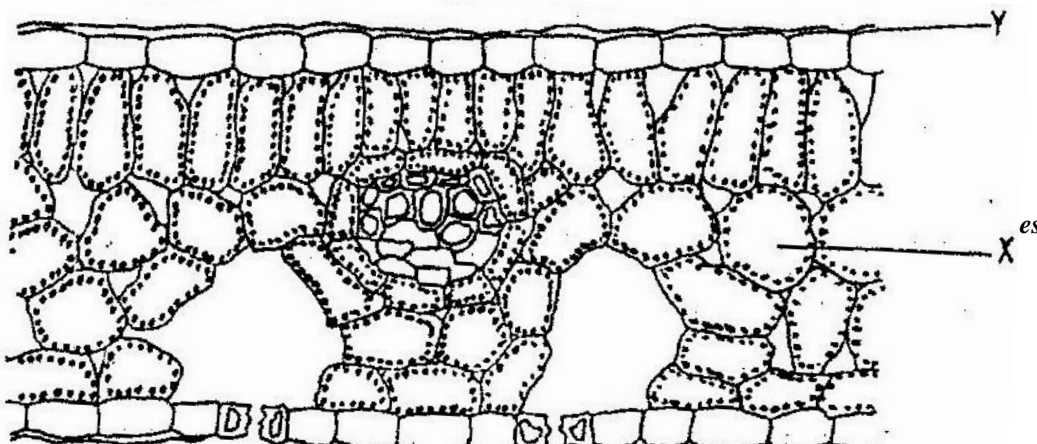

- (b) Name the parts labeled X, and Y
- (c) Using arrows indicate on the diagram the direction of flow of water during the transpiration stream
- (d) State two ways in which the leaf is suited to gaseous exchange

12. The chart below represents the result of successive crosses, starting with red- flowered plants and white flowered plants and in which both plants are pure breeding.

Parental genotypes: Red flowers x white flowers

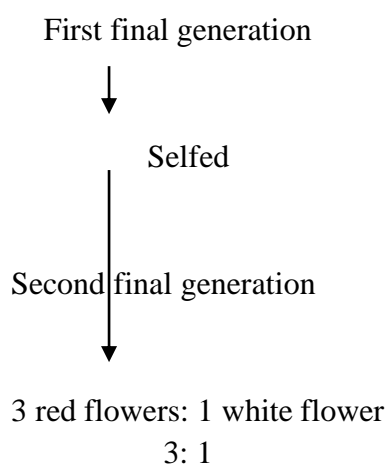

- (a) What were parental genotype? Use letter R to represent the gene for red colour and r for white colour
- (b) (i) What was the colour of the flowers in the first filial generation?
(ii) Give a reason for your answer in b (i) above
- (c) If 480 red flowered plants were obtained in the second filial generation, how many F₂ plants and white flowers? Show your working.

13. The temperature of a person was taken before, during and after taking a cold bath. The results are shown in the graph below

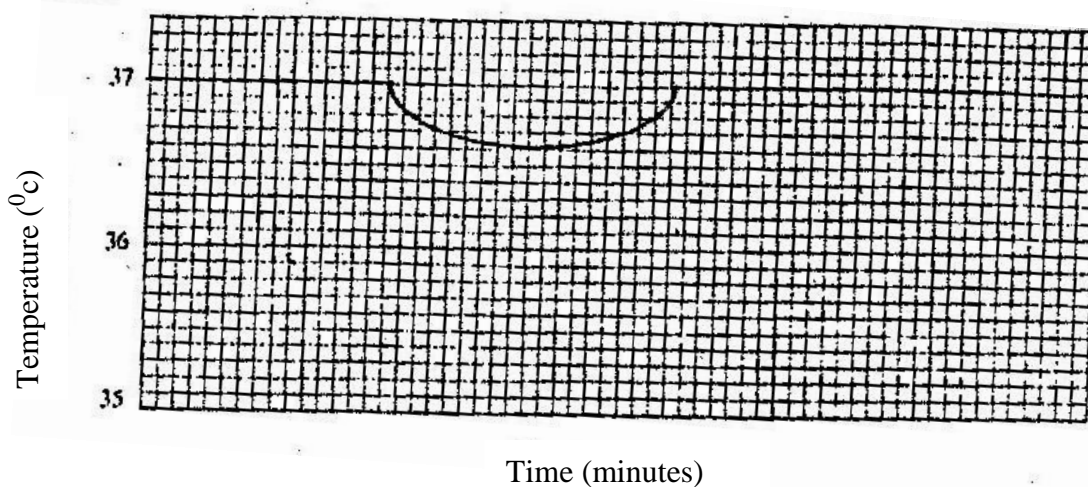

- (a) Explain why the temperature fell during bath
- (b) What changes occurred in the skin that enabled the body temperature to return to normal?
14. (a) Name the crop infested by phytophthora infestans and the disease it causes
Crop / Disease
- (b) State four control measures against the disease

15. The concentration of the lactic acid in blood during and after an exercise was determined. The results are shown in the graph below

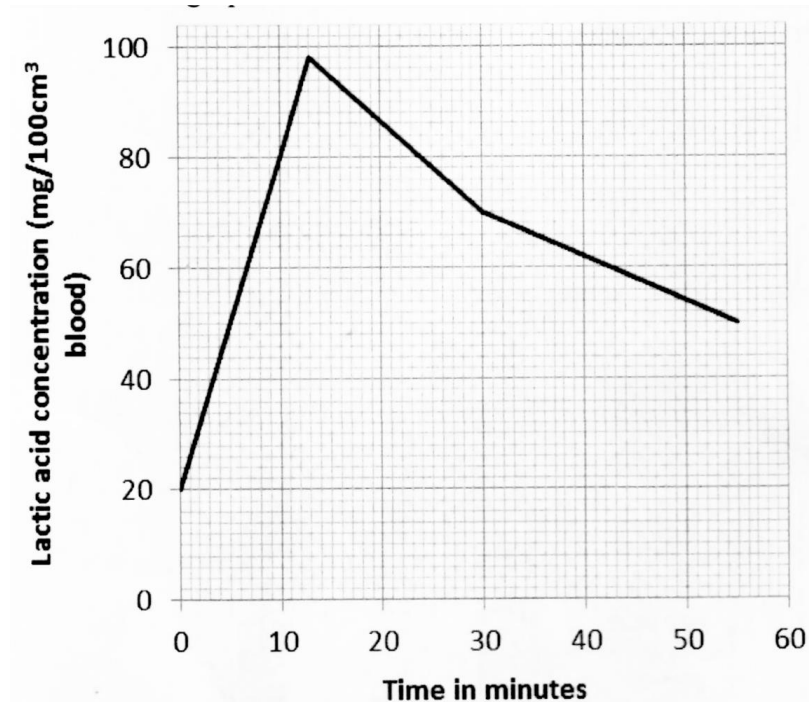

- (a) (i) By how much did the lactic acid increase at the end of 13 minutes?
- (ii) After how many minutes was the lactic acid concentration 71mg/100cm³?
- (iii) What would be the concentration of lactic acid at the 60th minute?
- (b) Give a reason for the high rate of production of lactic acid during the Exercise
- (c) Give a reason for the decrease in the concentration of lactic acid after the exercise
16. (a) What is the significance of sexual reproduction?
- (b) State three advantages of asexual reproduction

17. The numbers of different types of animals supported by a square kilometer in two terrestrial ecosystems are shown in the table below

Type of ecosystem	Type of animal	Number of animals supported per sq. km
Acacia savannah	Domestic animals	
	Cattle	7
	Goat	30
	Sheep	10
Bush land	Wild games	
	Thomsons's gazelles	450
	Eland	20
	Wildebeest	60
	Domestic animals	
	Cattle	2
	Goats	15
	Sheep	5
	Wild game	
	Thomson's gazelles	200
Eland	12	
Wildebeest	10	

- (a) (i) Which domestic animal is better adapted to both ecosystems?
(ii) Give a reason why the animal named in (a) (i) above is better adapted to the two ecosystems.
- (b) Why are cattle and sheep fewer in the bush land than in the savannah?
- (c) (i) Name suitable methods that were used to estimate the population of:
Domestic animals
Wild animals
(ii) Give a reason why the method named for wild animals in (c) (i) above is suitable
- (d) state three methods which could be used to determine the diet of wild animals in an ecosystem
- (e) Name four biotic factors that could have regulated the animal population in both ecosystems
- (f) State four human activities that affect population of animals in game parks
- (g) What is the importance of national park to a nation?
18. describe the role of hormones in the human menstrual cycle

19. how are leaves of mesophytes suited to their functions

BIOLOGY
K.C.S.E PAPER 231/1 2001
QUESTIONS

1. Other than having many features in common, state the other characteristics of a species
2. Why are green plants referred to as primary producers in an ecosystem?
3. A person whose blood groups is AB requires a blood transfusion. Name the blood groups of the donors.
4. Name the parts of the flower that are responsible the production of gametes
5. State two functions of muscles found in the alimentary canal of mammals.
6. Adult elephants flap their ears twice as much as their calves in order to cool their bodies when it is hot. Explain.
7. Name the organelle in which protein synthesis takes place
8. (a) The type of circulatory system found in members of the class insecta is

(b) Name the blood vessel that transports blood from:
(i) Small intestines to the liver
(ii) Lungs to the heart
9. Name three types of chromosomal mutations
10. Name three sites where gaseous exchange takes place in terrestrial plants.

SECTION B

11. The diagram below represents a mammalian nephron

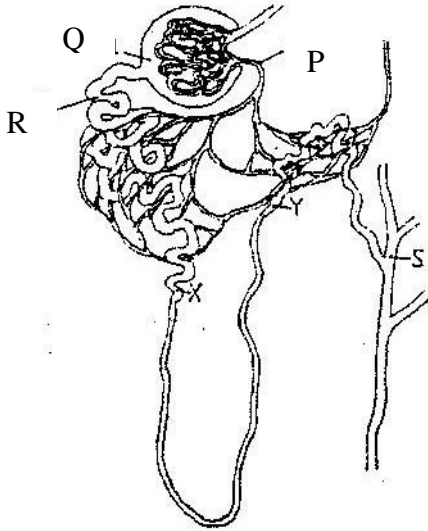

- (a) Name the
 - (i) Structure labeled P
 - (ii) Portion of the nephron between point X and Y
- (b) Name the process that takes place at point Q
- (c) Name one substance present at point R but absent at point S in a healthy mammal
- (d) The appearance of the substance you have mentioned in (c) above is a symptom of a certain disease caused by a hormone deficiency. Name the
 - (i) Disease
 - (ii) Hormone
- (e) State the structural modifications of nephrons found in the desert mammals

12. The graph below shows the effect of substance concentration of the rate of enzyme reaction.

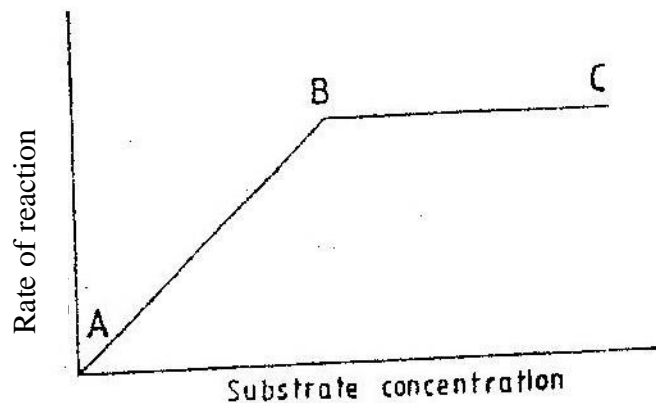

Substrate concentration

- (a) (i) Account for the shape of the graph between A and B
- (ii) B and C
- (b) How can the rate of reaction be increased after point B?
- (c) State two other factors that effect the rate of reaction of enzyme reaction

13. The diagram below represents the nitrogen cycle

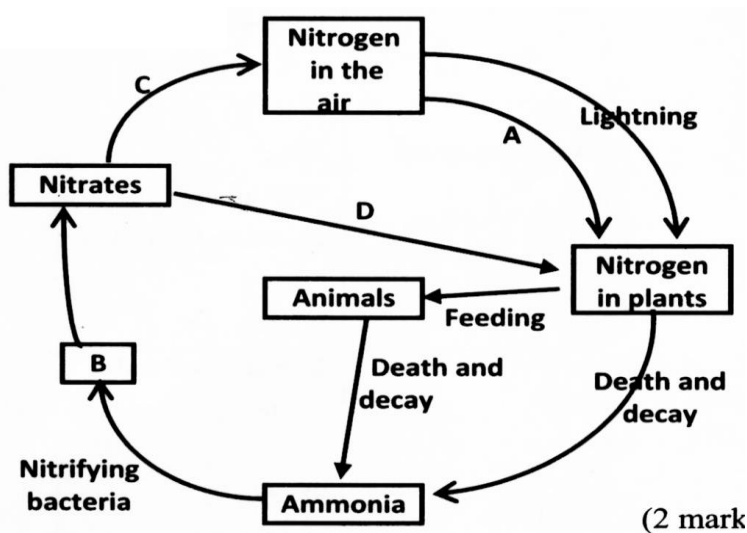

- (a) State the process labeled
 - A
 - D
- (b) Name the compound represented by B
- (c) Name the group of organisms labeled C
- (d) (i) name the group of plants which promote process A
- (ii) State the part of the plant where process A takes place
- (e) How would excess pesticides in the soil interfere with process A

14. Tallness in pea plants is due to a dominant gene
 Two tall pea plants were crossed and their F1 generation were in the ratio of 3 tall: 1 short. Using letter T to represents the gene for tallness and t for shortness give the

- (a) (i) genotype of the parents
(ii) Gamete of the parents
(iii) Genotype ratio of the F1 generation
- (b) What is meant by the term testcross in genetic studies?

15. The diagram below represents a set up to investigate the conditions necessary for seed germination.

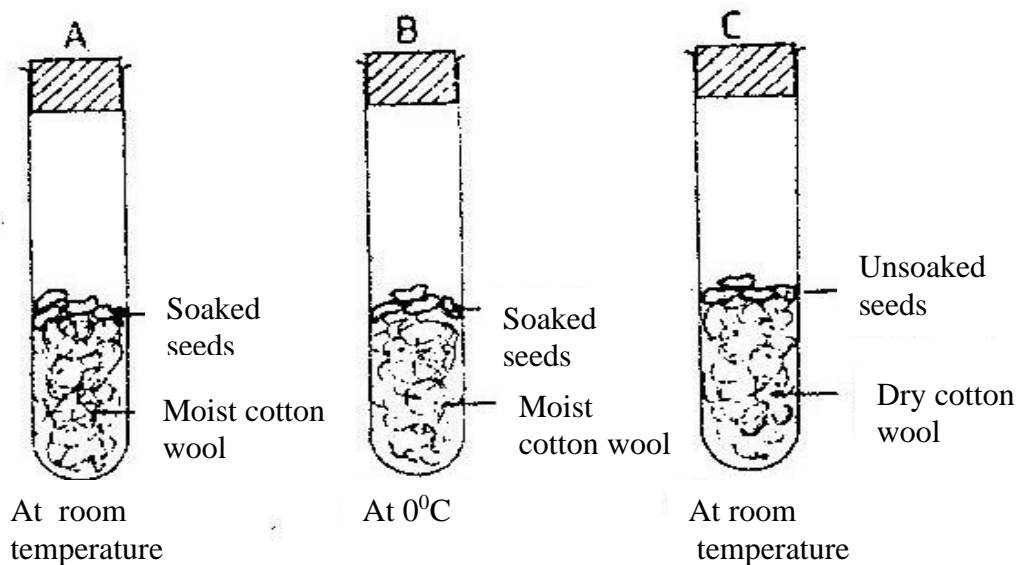

The set up was left for 7 days

- (a) What conditions were being investigated in the experiment?
(b) State three reasons for soaking seeds in set ups A and B
(c) What were the expected results after seven days?

SECTION C

16. An experiment was carried out to investigate the nutritional value of two dry powder animal feeds X and Y over a period of six months. Twenty 5 month's old castrated goats were used. The goats were divided into two equal groups A and B.

The animals in group A were fed on feed X throughout the experiment while those of group B were fed on feed Y.

The feeds were supplemented with dry hay and water. The average body weight of each group of goats and the weight of the dry powder feeds were determined and recorded each month. The faeces produced by each group was dried and weighed and the average dry faecal output per month was also recorded. The results are as shown below.

	GROUP	A		GROUP	B	
Months since commencement of the experiment	Average total weight of goats (kg)	Average weight of total feed.(kg)	Average monthly dry faecal output (kg)	Average total weight of goats(kg)	Average weight of total feed (kg)	Average monthly dry faecal output (kg)
0	20.4	26.7	10.5	20.5	35.4	16.5
1	22.5	27.5	10.7	19.5	34.3	17.7
2	24.5	25.8	10.3	19.0	35.2	17.2
3	26.3	18.5	8.8	18.5	36.1	17.5
4	28.0	16.6	7.2	17.1	36.0	16.9
5	29.4	16.3	6.0	16.3	35.8	16.8
6	29.5	16.1	5.6	15.6	35.5	16.6

- (a) (i) What is the relationship between the amount of feed and the faecal output
- (ii) Work out the average increase in weight for the animal's in group A during
The first four months
The last two months
- (iii) Account for the average increase weight in goats in group A during the first four months
The last two months
- (iv) Which of the two feeds is more nutritious?
Give reason for your answer
- (b) State four uses of digested food in the bodies of animals
- (c) State four uses of water in the bodies of animals

17. (a) State the functions of the following parts of the mammalian ear;
- (i) Tympanic membrane
- (ii) Eustachian tube
- (iii) Ear ossicles

- (b) Describe how semicircular canals perform their functions
18. (a) Describe the process of fertilization in a flowering plant
- (b) State the change that take place in a flower after fertilization

BIOLOGY
K.C.S.E PAPER 231/1 2002
QUESTIONS

1. Beside the abdomen, name the other body part of members of Arachnida,
2. a) Name the bacteria found in the root nodules of leguminous plant
b) State the association of the bacteria named in (a) above with the leguminous plants.
3. a) State the function for co-factors in cell metabolism
b) Give one example of a metallic co – factor
4. During germination and early growth, the dry weight of the endosperm decreases while that of the embryo increases. Explain.
5. State two characters that researchers select in breeding programme.
6. In what form is oxygen transported from the lungs to the tissues?
7. Explain why the carrying of wild animals is higher than that for cattle in a given piece of land.
8. Which type of joint is found at the articulations of
a) Pelvic girdle and femur
b) Humerus and ulna?
9. Name two gaseous exchange structures in higher plants.
10. What happens to excess fatty acids and glycerol in the body?
11. Give an example of a sex – linked trait in humans on:

Y CHROMOSOME.
X CHROMOSOME.

12. The chart below represents a simplified carbon cycle.

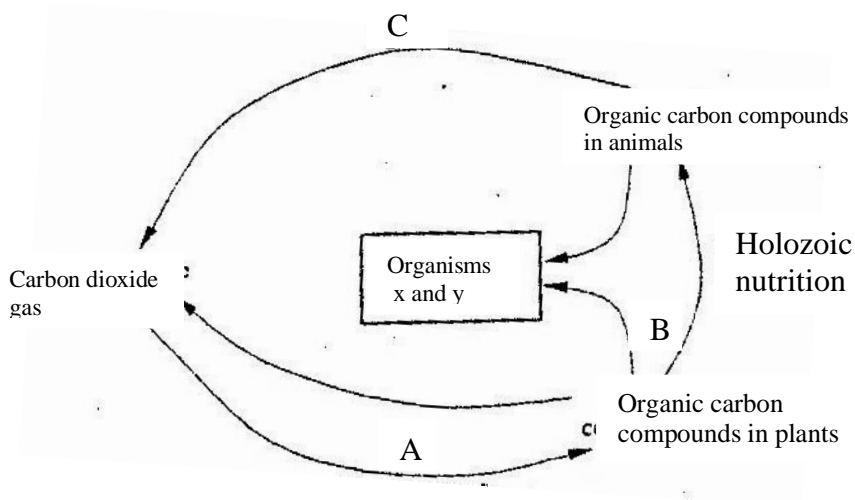

(a) Name the process labeled A, B, and C

A
B
C

b) Name the organisms X and Y

X Y

c) State the importance of carbon cycle in nature

13. The chart below shows the number of chromosomes before and after cell division and fertilization in a mammal.

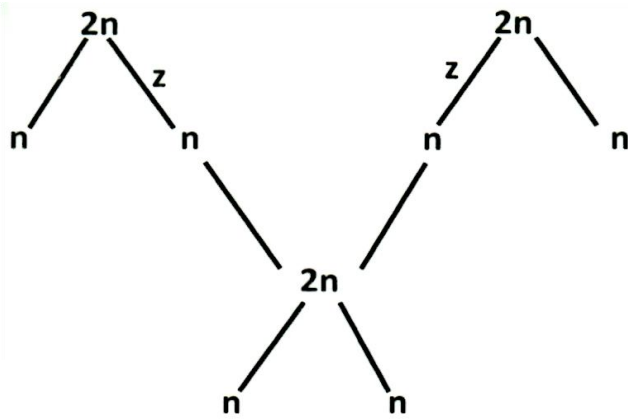

- a) What type of cell division takes place at Z
 - b) Where in the body of a female does process Z occur
 - c) On the chart, indicate the position of parents and gametes
 - d) Name the process that leads to addition or loss of one or more chromosomes.
 - e) State three benefits of polyploidy in plants to a farmer
14.
 - a) What is organic evolution
 - b) State two ways in which Homo sapiens differs from Homo habilis
 - c) Distinguish between divergent and convergent evolution giving example in each case.
15. Ascaris lumbricoides in an example for an endo – parasite
 - a) The name Ascaris refers to
 - b) State the habitat of the organism
 - c) State three ways in which the organism is adapted to living in its habitat.
16. The diagram below represents part of phloem tissue.

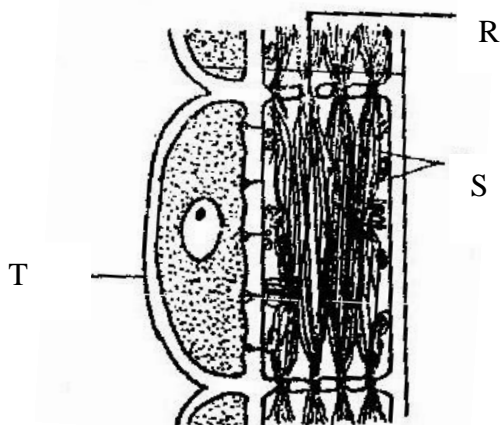

a) Name the structures labeled R and S and the cell labeled T.

R-

S-

Cell labeled T

b) State the function of the structure labeled S

c) Explain why xylem is a mechanical tissue

17. a) What structures are produced by sisal for vegetative propagation?

b) Give a reason for grafting in plants

c) State four advantages of vegetation propagation.

Time (minutes)	Glucose level in blood(Mg / 100cm ³)	
	X	Y
0	87	84
15	112	123
30	139	170
45	116	188
60	100	208
90	95	202
120	92	144
150	88	123

18. Two person X and Y drunk volumes of concentrated solution of glucose. The amount of glucose in their food was determined at intervals. The results are shown in the table below:

a) On the grid provided, plot graphs of glucose level in blood against time on the same axes.

b) What was the concentration of glucose in the blood of X and Y at the 20th minute?

X = 120 + -3)

$$Y = 140 \pm 3)$$

- c) Suggest why the glucose level in person X stopped rising after 30 minutes while it continued rising in person Y.
 - d) Account for the decrease in glucose level in person X after 30 minutes and person Y after 60 minutes (3 minutes)
 - e) Name the compound that stores energy released during oxidation of glucose.
 - f) Explain what happens to excess amino acids and development of plants.
19. Describe the role of hormones in the growth and development of plants.
20. a) Name three types of skeletons found in multicellular animals
b) Describe how the cervical, lumbar and sacral vertebrae are suited to their functions.

BIOLOGY
K.C.S.E PAPER 231/1 2003
QUESTIONS

SECTION A (20 MARKS)

Answer all the questions in this section in the spaces provided.

1. A process that occurs in plants is represented by the equation below.

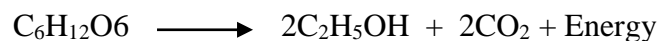

(Glucose) (Ethanol) (Carbon dioxide)

- a) Name the process.
 - b) State the economic importance of the process named in (a) above
2. Name the phylum whose members possess notochord
3. How do the male gamete nuclei reach the ovule after pollen grains land on the stigma?

4. a) Name the bacteria found in root nodules of leguminous plants.
 b) What is the role of the bacteria named in (a) above?
5. A bone obtained from a mammal is represented by the diagram below.

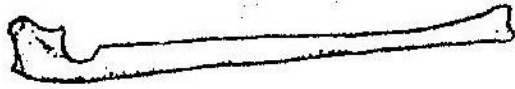

- a) Name the bone.
 b) Which bones articulate with the bone shown in the diagram at the notch?
6. Distinguish between analogous and homologous structures.
 Analogous structures –
 Homologous structures –

7. The diagram below represents regions of a root tip.

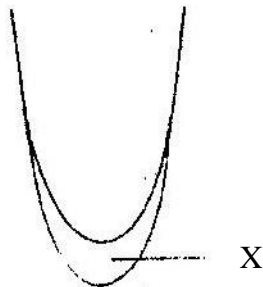

- a) Name the two regions above X in ascending order
 b) State the function of the part labeled X
8. State a function of the large intestine in humans
9. Name the:
 a) Material that strengthens xylem tissue.
 b) Tissue that is removed when the bark of a dicotyledonous plant is ringed.
10. How are leaves of submerged adapted plants for photosynthesis?
11. Name the causative agent of typhoid.

SECTION B (40 MARKS)

Answer all the questions in this section in the spaces provided.

12. a) What is meant by the term sex – linkage?
 b) Name two sex – linked traits in humans.

- c) In *Drosophila Melanogaster*, the inheritance of eye colour is sex – linked. The gene of red eye is dominant. A cross was made between a homozygous red – eyed female and a white – eyed male. Work out the phenotypic ration of F₁ generation. (Use R to represent the gene for red eyes).

13. The diagram below shows gaseous exchange in tissues.

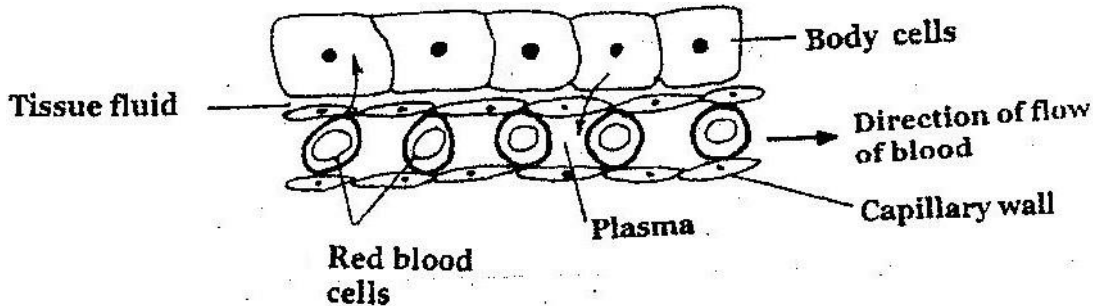

- a) Name the gas that diffuses:
- To the body cells
 - From the body cells
- b) Which compound dissociates to release the gas named in (a) (i) above?
- c) i) what is tissue fluid?
ii) What is the importance of tissue fluid?
- d) Name the blood vessel with the highest concentration of:
- Glucose
 - Carbon dioxide
14. a) Explain how marine fish regulate their osmotic pressure.
b) Explain the role of antidiuretic hormone when there is excess water in the human body.
15. A response exhibited by a certain plant tendril is illustrated below.

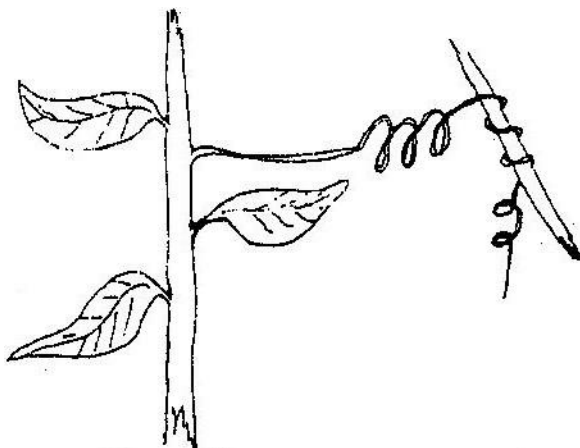

- a) i) Name the type of response
- ii) Explain how the response named in (a)(i) above occurs
- b) What is the importance of tastic responses to microscopic plants?
- c) State four applications of plant hormones in agriculture.

16. a) What is meant by:
- i) Autecology
 - ii) Synecology?

- b) The number and distribution of stomata on three different leaves are shown in the table below:

Leaf	Number of stomata	
	Upper epidermis	Lower epidermis
A	300	
B	150	
C	02	

Suggest the possible habitat of the plants from which the leaves were obtained

Leaf	Habitat
A	
B	
C	

- (c) State the modifications found in the stomata of leaf C.

SECTION C (40 marks)

Answer question 17 (compulsory) in the spaces provided and either question 18 or 19

17. Some students used a model to demonstrate the effect of sweating on human body temperature. Two boiling tubes A and B were filled with hot water. The temperature of water in the tubes was taken at the start of the experiment and then at 5 minutes interval. The surface of tube A was continuously wiped with a piece of cotton wool soaked in methylated spirit. The results obtained are shown in the table below.

Time (minutes)	Temperature ⁰ C in tubes	
	A	B
0	80	80
5	54	67
10	40	59
15	29	52
20	21	47
25	18	46

- a) On the same axes, plot graphs of temperature of water in the tubes against time.
- b) At what rate was the water – cooling in tube A?
- c) Why was tube B included in the set up?
- d) Account for the rate of cooling in tube A.
- e) State two processes of heat loss in tube b.
- f) What would be the expected results if tube A was insulated?
- g) What would the insulation be comparable to in:
 - i) Bird
 - ii) Mammals?
- h) Name the structures in the human body that detect:
 - i) External temperature changes
 - ii) Internal temperature changes

18. Describe the functions of the various parts of the human eye.
19. Describe how fruits and seeds are suited to their modes of dispersal.

BIOLOGY

K.C.S.E PAPER 231/1 2004

QUESTIONS

Section A (20 marks)

- 1.a) Name the cartilage found between the bones of the vertebral column (1mk)
- b) State the function of the cartilage named in (a) above (1mk)
2. Distinguish between natural and acquired immunity (2mks)
3. How is aerechyma tissue adapted to its function (2mks)

4. Other than carbon dioxide, name other products of anaerobic respiration (2mks)
5. During which phase of meiosis does crossing over occur. (2mks)
6. The diagram below shows the position of an image formed in a defective eye.

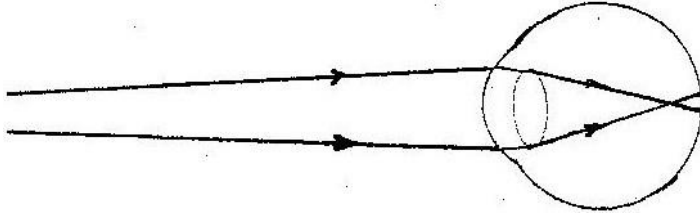

- a) Name the defect:
- b) Explain how the defect named in (a) above can be corrected (2mks)
- c)
7. State the function of the organelles:
- a) Lysosomes (1mks)
- b) Golgi apparatus (2mks)
8. Name the class in the phylum arthropoda which has the largest number of individuals? (1mks)
9. Name two mineral elements that are necessary in the synthesis of chlorophyll. (2mks)
10. How are the xylem vessels adapted for support? (1mk)
11. Fruit formation without fertilization is called (1mk)

SECTION B (40 MARKS)

12. Across between a red flowered plant and white flowered produced plants with pink flowers.
Using letter R to represent the gene for red colour , and W for white colour
- a) What were the parental genotypes (1mks)
- b) Workout a cross between F1 plants (4mks)

- c) Give the i) Phenotypic ratio of F₂ plants (1mk)
 ii) Genotypic ratio of F₂ plants (1mk)
- d) Name a characteristic in humans, which is controlled through a mammalian heart?

13. The diagram below shows a vertical section through a mammalian heart.

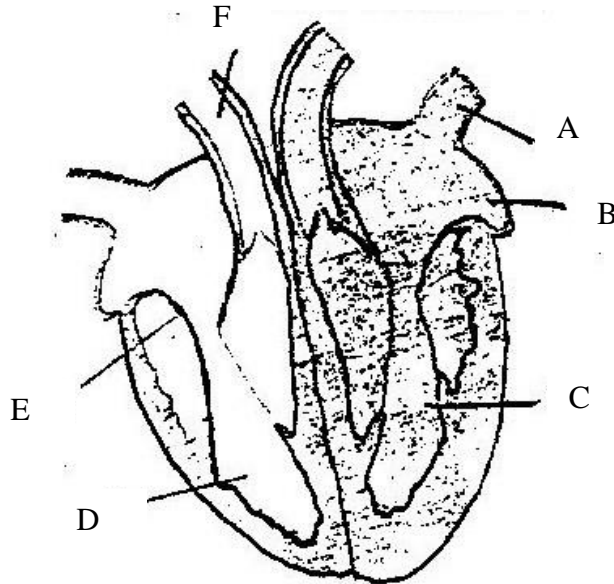

- a) Name the parts labeled A, B, E and F (4mks)
- b) Use arrows to show the direction in which blood flows in the heart. (2mks)
- c) Give a reason why the wall of chamber C is thicker than chamber D (2mks)
14. a) What is the difference between Darwinian and Lamarckian theories of evolution? (2mks)
- b) What is meant by the following terms? Give an example in each case.
 i) Homologous structures
 ii) Example
 iii) Vestigial structures
 Example (6mks)
15. a) Give the differences between the following structures in wind and insect pollinated flowers. (3mks)
 i) Anther
 ii) Pollen grains
 iii) Stigma (1mk)

b) What is the importance of cross pollination? (1mk)

c) Explain how a seed is formed after an ovule is fertilized (4mks)

16. a) What is diffusion (2mks)

b) how do the following factors affect the rate of diffusion?

i) Diffusion gradient (1mk)

ii) Surface area volume ratio (1mk)

iii) Temperature (1mk)

c) Outliner three roles of active transport in the human body (3mks)

SECTION C (40MKS)

Answer question 17. (Compulsory) in the space provided and either question 18 or 19

17. During germination and growth of a cereal, the dry weight of endosperm, the embryo and total dry weight were determined at two – day intervals.

The results are shown in the table below.

Time after planting (days)	Dry weight of endosperm	Dry weight of embryo (mg)	Total dry weight (mg)
0	43	2	45
2	40	2	42
4	33	7	40
6	20	17	37
8	10	25	35
10	6	33	39

a) Using the same axes, draw graphs of dry weigh of endosperm, embryo and the total dry weight against time (7mks)

b) What is the total dry weight on day 5?

c) Account for:

i) Decrease in dry weight of endosperm from day 0 to 10 (2mks)

ii) Increase in dry weight of embryo from day 0 day 10 (2mks)

iii) Decrease in total dry weight from day 0 to day 8 (2mks)

iv) Increase in total dry weight after day 8 (1mks)

Dormancy.

- i) Within a seed
 - ii) Outside the seed
- e) Give two characteristics of meristematic cells (2mks)
18. How is the mammalian skin adapted to its functions? (20mks)
19. Explain how a biotic factors affect plants (20mks)

BIOLOGY
K.C.S.E PAPER 231/1 2005
QUESTIONS

SECTION A (20 MKS)

Answer all the questions in this section in the spaces provided.

1. Apart from hearing, state another function of the human ear. (1mk)
2. The diagram below represents a cell.

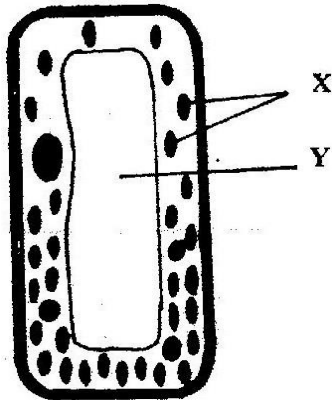

- (a) Name the parts labeled X and Y (2mk)
X
 - Y
 - (b) Suggest why the structures labelled X would be more on one side than the other. (1mks)
3. What is the role of the vascular bundles in plant nutrition? (3mks)
 4. What is meant by
 - a) Organic evolution (1mks)
 - b) Continental drift? (1mks)
 5. To which class does an animal with two body parts and four Pairs of legs belong? (1mk)
 6. Name the substance which accumulates in muscles when respiration occurs with insufficient oxygen. (1mks)
 7. State the importance of osmosis in plants. (3mks)
 8. Name three factors in seeds that cause dormancy. (3mks)
 9. Why would carboxyhaemoglobin lead to death? (2mks)
 10. Name the organism that causes amoebic dysentery.

- a) Name the process through which energy from the sun is incorporated into the food web. (1mk)
- b) State the mode of feeding of the birds in the food web (1mk)
- c) Name two ecosystems in which the organisms in the food web live (1mk)
- d) From the information in the food web, construct a food chain with the large bird as a quarternary consumer. (1mk)
- e) What would happen to the organisms in the food web if bird N migrated? (3mks)
- f) Not all the energy from one trophic level is available to the next level. Explain (3mks)
- g) (i) Two organisms which play a role in the ecosystems are not included in the food web. Name them. (2mks)
- (ii) State the role played by the organisms named in g(i) above. (1mk)

SECTION B (40 MKS)

Answer all the questions in this section in the spaces provided.

11. The diagram below represents a part of the rib cage.

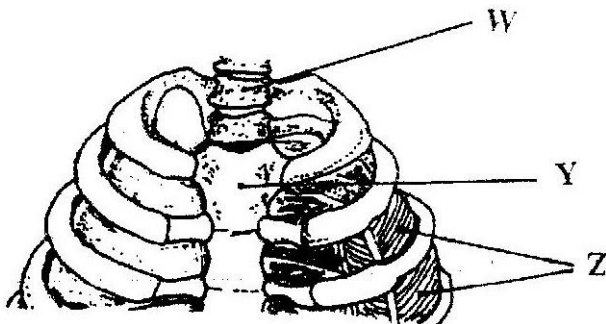

- a) Name the parts labeled W, Y and Z. (3mks)
 W
 Y
 Z
- b) How does the part labeled Z facilitates breathing in? (3mks)

12. In a garden with plants of same species, 705 plants had red flowers

while 224 had white flowers.

- a) Work out the ratio of red to white flowered plants (1mk)
- b) (i) Using letter R to represent the dominant gene, work out a cross between F1 offspring and a white flowered plant. (4mks)
- (ii) What is the genotypic ratio from the cross in b(i) above? (1mk)
- c) What is meant by the term allele? (1mk)

13. The diagram below shows a section through the mammalian skin.

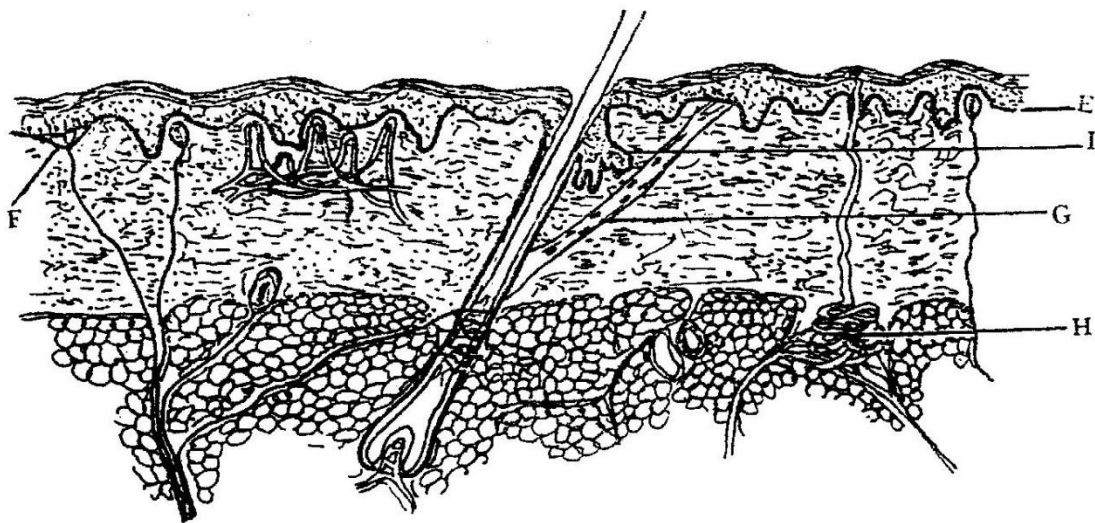

- a) Name the parts labeled E, F and G. (3mks)
 - E
 - F
 - G
- b) State two functions in each case of substance secreted by the structures labeled.
 - (i) H (2mks)
 - (ii) I (2mks)

14. A set up that was used to investigate certain process in plants is shown in the diagram below.

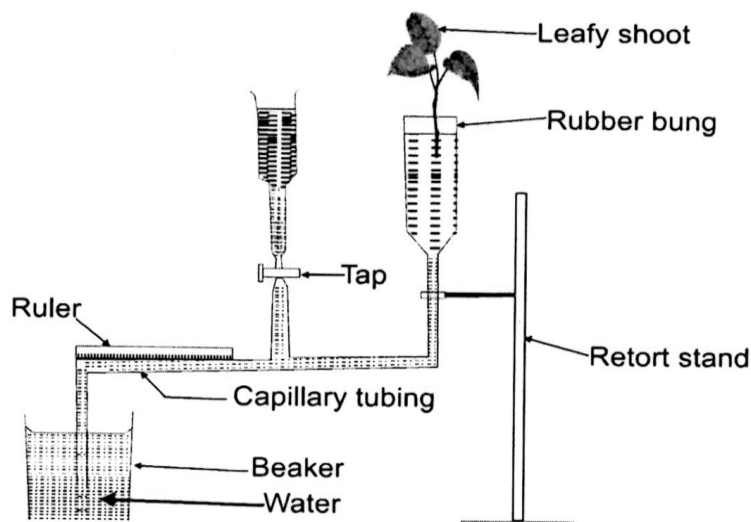

- a) What process was being investigated? (1mk)
- b) (i) State two precautions that should be taken when setting up the experiment. (2mks)
- (ii) Give a reason for each precaution stated in b(i) above. (2mks)
- c) State three environmental factors that influence the process Under investigation. (3mks)
15. a) What is meant by the terms (1mk)
- (i) Epigymous flower (1mk)
- (ii) Staminate flower? (1mk)
- b) How are the male parts of wild pollinated flowers adapted to their function? (4mks)
16. a) Name two organisms that cause food spoilage (2mks)
- b) Name two modern methods of food preservation and for each state the biologic principle behind it. (4mks)

SECTION C (40 MKS)

Answer question 17 (compulsory) and either question 18 or 19 in the spaces provided

17. After an ecological study of feeding relationships students constructed the food web below.

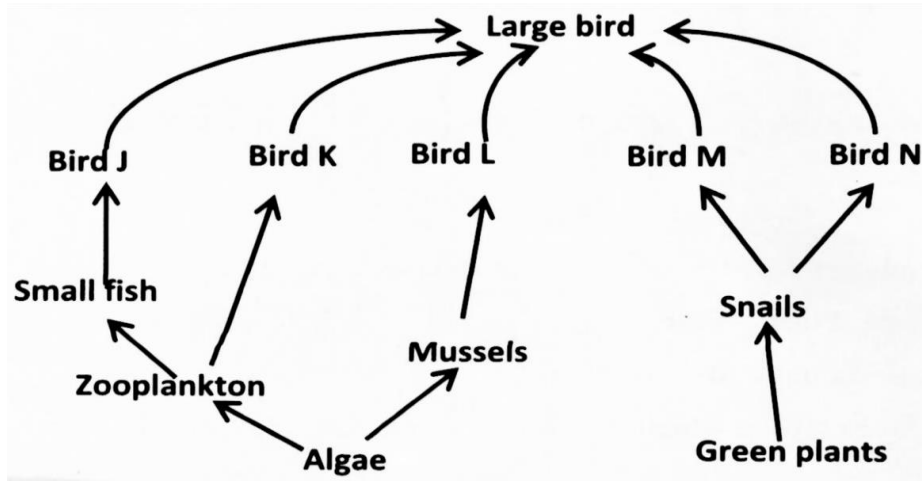

- a) i) State three human activities that would affect the ecosystems. (3mks)
- ii) Explain how the activities stated in h(i) above would affect the ecosystems. (3mks)
18. Describe how gaseous exchange takes place in terrestrial Plants. (20mks)
19. How is the human eye adapted to its function? (20mks)

BIOLOGY
K.C.S.E PAPER 231/1 2006
QUESTIONS

1. a) State the functions of cristae in mitochondria.
b) The diagram below represents a cell organelle.

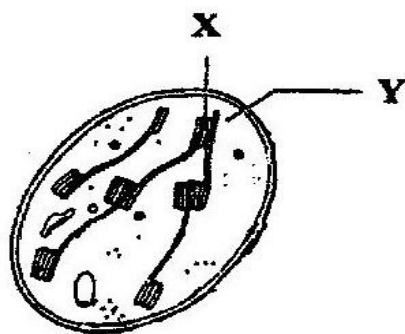

- (i) Name the part labeled Y. (1mk)
(ii) State the functions of the part labeled X. (1mk)
2. Name the part of the flower that develops into
a) Seed
b) Fruit (1mk)
3. a) Name two tissues in plants which are thickened with lignin. (2mks)
b) How is support attained herbaceous plants? (1mks)
4. a) Name the fluid that is produced by sebaceous glands. (1mk)
b) What is the role of sweat in human skin? (2mks)
5. State two ways in which floating leaves of aquatic plants are adapted to gaseous exchange. (2mks)
6. a) State three characteristics of Monera that are not found in other kingdoms. (3mks)
b) Name the class to which a termite belongs (1mk)
7. a) Name one defect of circulatory system in humans. (1mk)
b) state three functions of blood other than transport. (3mks)

8. State the role of vitamin C in humans. (2mks)
9. a) State two processes which occur during anaphase of mitosis. (2mks)
 b) What is significance of meiosis? (2mks)
10. State the important of tactic response among some members of kingdom protista. (1mks)
11. State the role of insulin in human body. (1mks)
12. An experiment was set up in the experiment as show below.

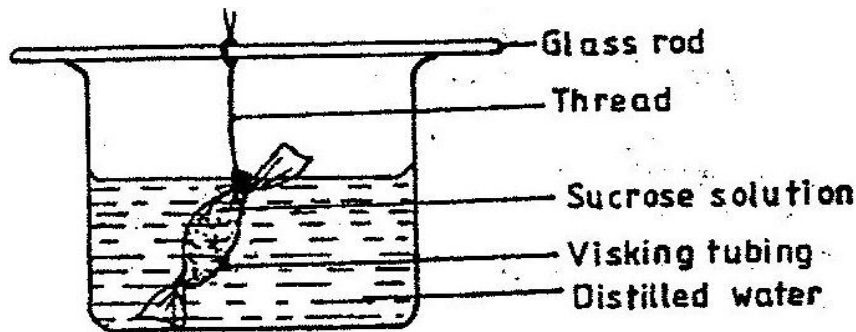

The set up was left for 30 minutes.

- a) State the expected results. (1mk)
- b) Explain your answer in (a) above (3mks)
13. a) In what form is energy stored in muscles (1mk)
 b) State the economic important of anaerobic respiration in plants. (2mks)
14. a) Distinguish between epigeal and hypogeal germination. (1,mk)
 b) Why is oxygen necessary in the germination of seeds? (2mks)
15. Explain continental drift as an evidence of evolution. (3mks)
16. What is the importance of the following in an ecosystem? (2mks)
 a) Decomposers
 b) Predation
17. a) Distinguish between the terms homodont and heterodont. (1mk)
 b) What is the function of carnassials teeth? (1mk)

c) A certain animal has no incisors, no canines, 6 premolars and 6 Molars in its upper jaw. In the lower jaw there are 6 incisors, 2 canines, 6 Premolars and six molars.
Write its dental formula.

18. a) State two functions of bile juice in the digestion of food. (2mks)

b) How does substrate concentration affect the rate of enzyme action? (1mk)

19 a) Explain how the following prevent self pollination. (1mk)

- (i) Protoadry
- (ii) Self – sterility.

b) Give three advantages of cross pollination. (3mks)

20 a) What name is given to response to contact with surface exhibited by tendrils and climbing stems in plants?

b) State three biological importance of tropisms plants.

21. The diagram below represents a reflex are in human.

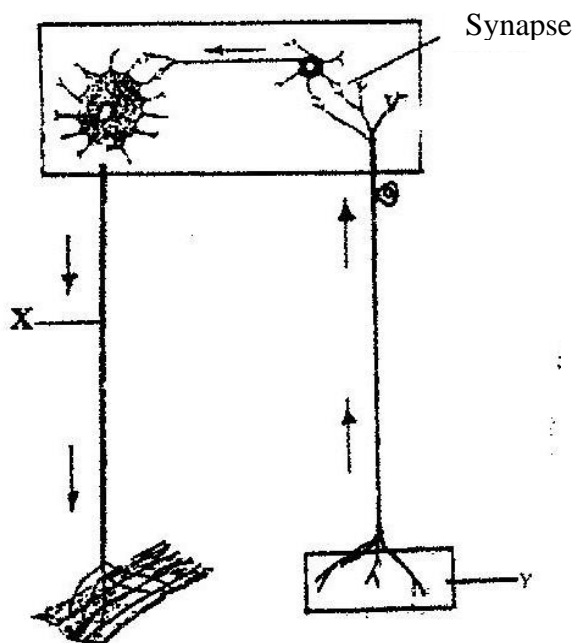

a) Name the parts labeled X and Y

b) Name the substance that is responsible for the transmission of an impulse across the synapse. (1mks)

22. a) State the function of ciliary muscles in the human eye. (1mk)

b) State two functional differences between the rods and cones in the human eye. (2mks)

23. State the function of each of the following parts of human ear. (4mks)

- a) Ear ossicles
- b) Cochlea
- c) Semi circular canals
- d) Eustachian tube.

24. State four ways in which respiratory surfaces are suited to their function. (4mks)

25. a) A dog weighing 15.2kg requires 216kj while a mouse weighing 50g requires 2736kj per day. Explain. (2mks)

26. The chart below represents a simplified nitrogen cycle.

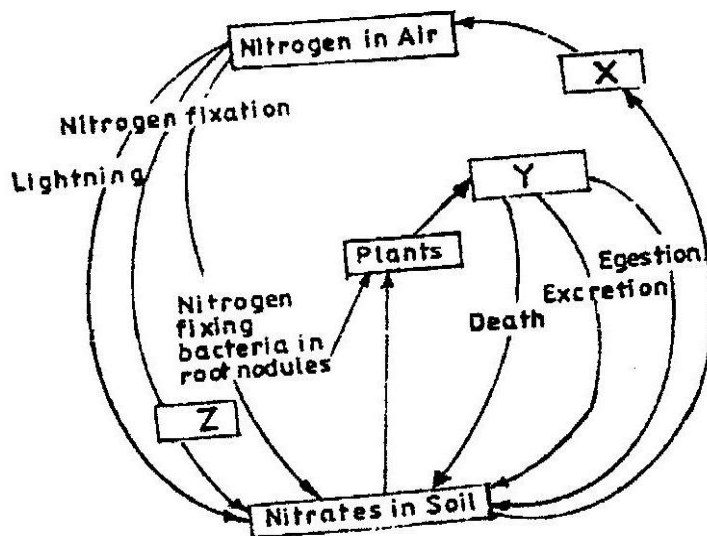

What is represented by X,Y, and Z?

27. Name the end products of the light stage in photosynthesis.

BIOLOGY
K.C.S.E PAPER 231/1 2007
QUESTIONS

1. (a) What is meant by the term binomial nomenclature (1 mk)
(b) Give two reasons why classification is important (2 mks)
2. (a) What is the formula for calculating linear magnification of a specimen when using a hand lens? (1 mk)
(b) Give a reason why staining is necessary when preparing specimens for observation under the microscope (1 mk)
3. Plant cells do not burst when immersed in distilled water. Explain (2 mks)
4. State three functions of Golgi apparatus (3 mks)
5. Distinguish between diffusion and osmosis (2 mks)
6. Describe what happens during the light stage of photosynthesis (3 mks)
7. The diagram below represents a section through a human tooth

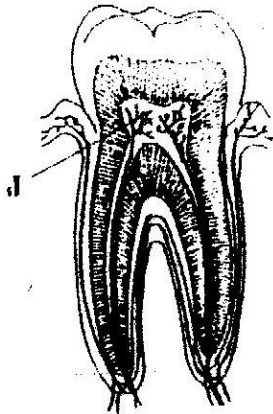

- (a) (i) Name the type of tooth shown (1 mk)
(ii) Give a reason for your answer in (a) (i) above (1 mk)
- (b) State the functions of the structures found in part labeled J (2 mks)
8. (a) Name a fat soluble vitamin manufactured by the human body (1 mk)
(b) State two functions of potassium in the human body (2 mks)
9. State two ways in which the root hairs are adapted to their function (2 mks)

10. The diagram below represents a plant tissue

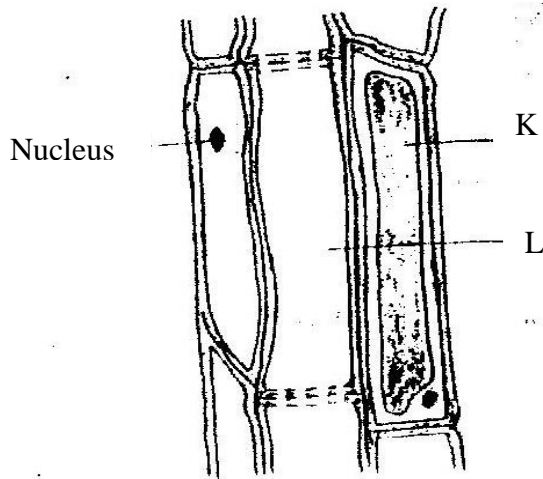

- (a) Name the tissue (1 mk)
- (b) Name the cells labeled K and L. (2 mks)
- K.....
- L.....
- (c) What is the function of the companion cell? (1 mk)
11. (a) What prevents blood in veins from flowing backwards? (1 mk)
- (b) State two ways in which the blood cells are adapted to their function (2 mks)
12. (a) Name two structures for gaseous exchange in aquatic plants (2 mks)
- (b) What is the effect of contraction of the diaphragm muscles during breathing in mammals? (3 mks)
13. (a) Name the products of anaerobic respiration in (1 mk)
- (i) Plants (1 mk)
- (ii) Animals (1 mk)
- (b) What is oxygen debt? (1 mk)
- 14 (a) What is the meaning of the terms (1 mk)
- (i) Homeostatic (1 mk)
- (ii) Osmoregulation? (1 mk)
- (b) Name the hormones involved in regulating glucose level in blood (2 mks)
- 15 (a) Distinguish between population and community (2 mks)
- (b) Name a method that could be used to estimate the population size

of the following organisms

(i) Fish in a pond (1 mk)

(ii) Black jack in a garden (1mk)

16 State two ways in which schistosoma species is adapted to parasitic mode of life (2 mks)

17 The diagram below represents a stage during cell division

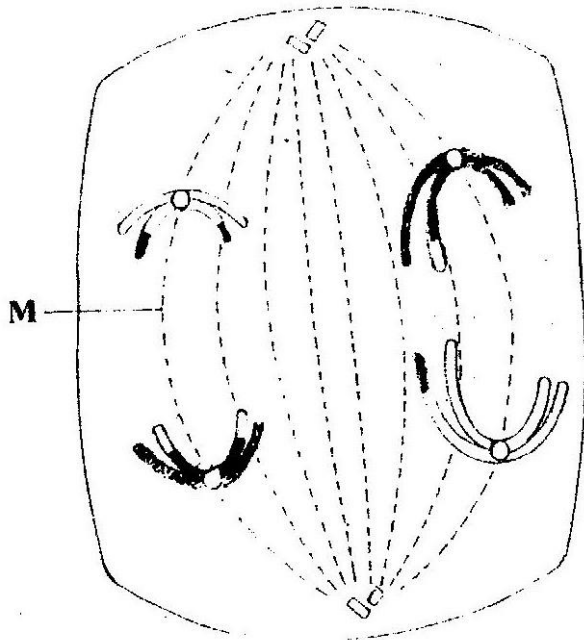

(a) (i) Identify the stage of cell division (1 mk)
(ii) Give three reasons for your answer in (a) (i) above (2 mks)

(b) Name the structures labeled M (1 mk)

18. State two disadvantages of sexual reproduction in animals (2 mks)

19 (a) State two environmental conditions that can cause seed dormancy (2 mks)

(b) Name the part of a bean that elongates to bring about epigeal germination

(1 mk)

20 (a) What is meant by the term allele? (1 mk)

(b) Explain how the following occur during gene mutation:

(i) Deletion (1 mk)

(ii) Inversion (1 mk)

(c) What is a test- cross? (1 mk)

21. (a) What is adaptive radiation (2 mks)

(b) Give a reason why organisms become resistant to drugs (1 mk)

22. (a) Where in the human body are relay neurons found (1 mk)

(b) The diagram below represents a neurone (1 mk)

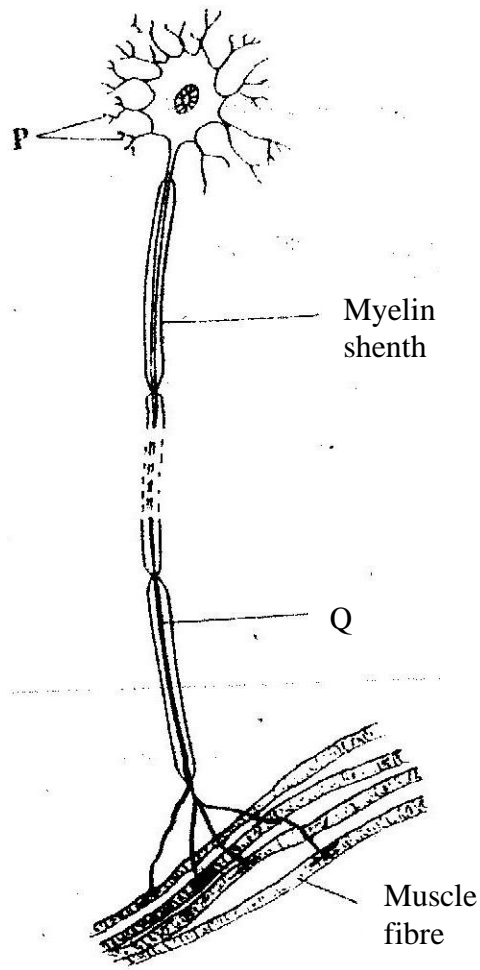

(i) Name the neurone (1 mk)

(ii) Name the parts labeled P and Q (2 mks)

P.....

Q.....

(c) State a function of myelin sheath (1 mk)

23 (a) Name the hormone that is responsible for apical dominance (1 mk)

(b) What is thigmotropism? (1 mk)

24. (a) state a characteristics that is common to all cervical vertebrae (1 mk)

(b) Name two tissues in plants that provide mechanical support (2 mks)

25. (a) The action of ptyalin stops at the stomach. Explain (1 mk)

(b) State a factor that denatures enzymes (1 mk)

- (c) Name the features that increase the surface area of small intestines (2 mks)

26. State one way by which HIV/AIDS is transmitted from mother to child (1 mk)

BIOLOGY
K.C.S.E PAPER 231/1 2008
QUESTIONS

1. Name the tissues in plants responsible for:
(a) Transport of water and mineral salts
(b) Transport of carbohydrates
(c) Primary growth (3 mks)
2. State the importance of the following processes that take place in the nephrons of a human kidney
(a) Ultra filtration (1 mk)
(b) Selective reabsorption (1 mk)
3. (a) Name a disease of the liver whose symptom is jaundice (1 mk)
(b) State the causative agent of:
(i) Cholera (1 mk)
(ii) Candidiasis (1 mk)

4. The diagrams below show a red blood cell that was subjected to a certain Treatment

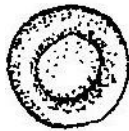

At start



At the end of experiment

- (a) Account for shape of the cell at the end of the experiment (2 mks)
- (b) Draw a diagram to illustrate how a plant cell would appear if subjected to the same treatment (1 mk)
5. (a) State two factors that affect enzymatic activities (2 mks)
- (b) Explain how one of the factors stated in (a) above affects enzymatic Activities (1 mk)

6. (a) What is meant by non- disjunction? (1 mk)
 (b) Give two examples of continuous variation in humans (2 mks)
7. (a) what is fossil (1 mk)
 (b) How does convergent evolution occur (3 mks)

8. The diagram below shows a stage in mitosis in a plant cell



- (a) Name the stage of mitosis (1mk)
 (b) Give two reasons for your answer in (a) above (2 mks)
 (c) Name the part of the plant from which the cell used in preparation was Obtained (1 mk)
9. Give three factors that determine the amount of energy a human being require in a day (3 mks)
10. (a) Name the antigens that determine human blood groups (2 mks)
 (b) State the adaptation that enables the red blood cells to move in blood Capillaries (1 mk)
11. (a) What is homeostasis? (1 mk)
 (b) Name three processes in the human body in which homeostasis is Involved (3 mks)
12. State two functions of the endoplasmic reticulum (2 mks)
13. (a) Name the part of retina where image is formed (1mk)
 (b) State two characteristics of the image formed on the retina (2 mks)
14. Describe the three characteristics of a population (3 mks)

15. Explain what happens when there is oxygen debt in human muscles (2 mk)

16. The diagram below represents a set up that was used to investigate certain process in a plant

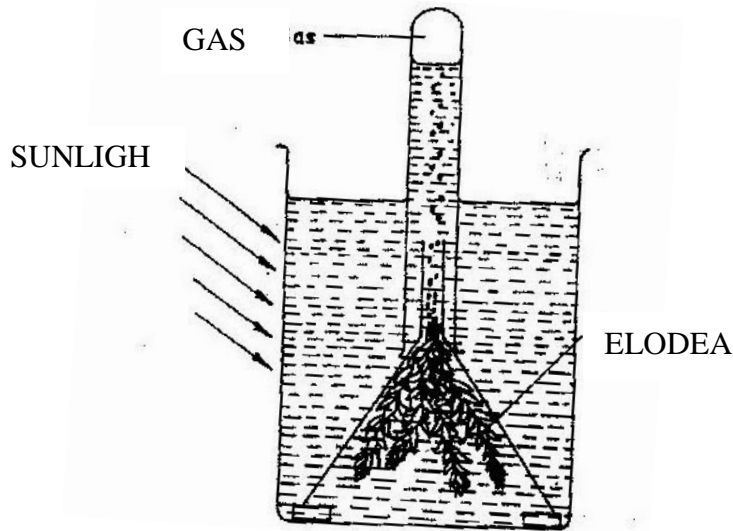

- (a) State the process that was being investigated (1 mk)
- (b) State a factor that would affect the process (1 mk)

17. Account for the following phases of a sigmoid curve of a growth of an organism

- (a) Lag phase (1 mk)
- (b) Plateau phase (1 mk)

18. How is the epidermis of a leaf of a green plant adapted to its function (2 mks)

19. The diagram below represents a tissue obtained from an animal



Hero Amos @0706851439 for more Resources

- (a) Identify the tissue (1 mk)
 (b) State the functions of the tissue named (a) above (1mk)
20. (a) what is a single circulatory system (1 mk)
 (b) Name an organism which has single circulatory system (1 mk)
- (c) Name the opening to the chamber of the heart of an insect (1 mk)
21. (a) What is seed dormancy (1 mk)
 (b) Name a growth inhibitor in seeds (1 mk)
22. State two characteristics of aerenchyma tissue (1 mk)
23. The diagram below shows a human tooth (2 mks)



- (a) Identify the tooth (1 mk)
 (b) How is the tooth adapted to its function (1 mk)
- (c) State the role of the following vitamins in the human body
 (i) C (1 mk)
 (ii) K (1 mk)
24. Name the sites where light and dark reactions of photosynthesis take place (2 mks)
 Light reaction
 Dark reaction
25. Giving a reason in each case, name the class to which each of the following organisms (4 mks)

Bean plant
Reason
Bat
Reason

30. The diagram below shows two fused bones of a mammal

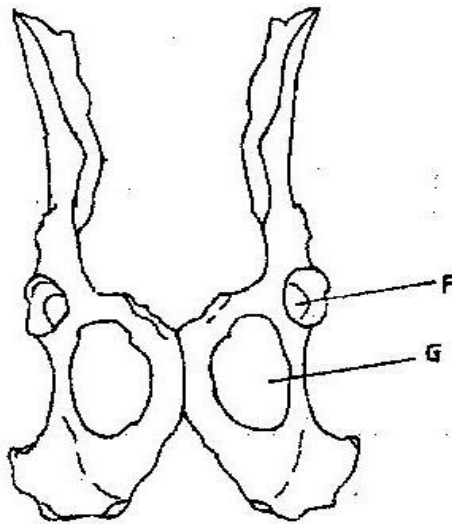

- (a) Identify the fused bone (1 mk)
- (b) Name the
- (i) Bone that articulates at the point labelled F (1 mk)
- (ii) The hole labelled G (1 mk)

BIOLOGY
K.C.S.E PAPER 231/1 2009
QUESTIONS

1. (a) Name the external feature which is common in birds, fish and reptiles (1 mk)
(b) State two characteristics of fungi (2 mks)
2. Name two benefits that a parasite derives from the host (2 mks)
3. State the functions of the following parts of a light microscope (2 mks)
 - (a) Objective lens
 - (b) Diaphragm
4. (a) The state during which a seed cannot germinate even when conditions for Germination are suitable is called (1 mk)
(b) The diagram below represents a stage during germination of a seed

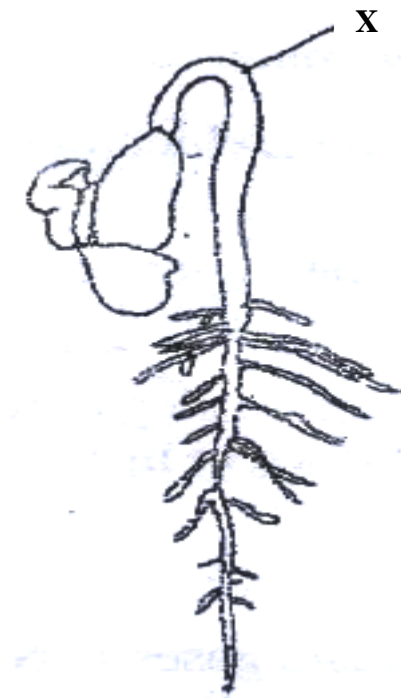

- (i) Name the type of germination illustrated in the diagram (1mk)
 - (ii) State the role of the part labeled x during germination of the seed (2 mks)
5. (a) What is meant by the following terms
(i) Hybrid vigour (1 mk)

(ii) Polyploidy? (1 mk)

(b) State two causes of chromosomal mutations (2 mks)

6. The diagram below shows a section through a plant organ

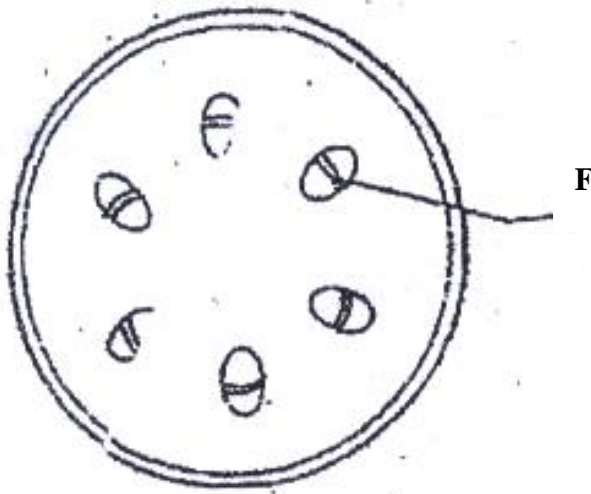

(a) (i) Name the class of the plant which the section was obtained (1 mk)

(ii) Give a reason for your answer in (a) (i) above

(b) State the functions of the part labeled F (1 mk)

7. State the function of the following cell organelles

(a) Ribosome (1 mk)

(b) Lysosomes (1 mk)

8. (a) Pregnancies continues if the ovary of an expectant mother is removed after 4 months explain (2 mks)

(b) What is the role of the testes in the mammalian reproductive systems? (2 mks)

9. (a) Name the causative agents of the following diseases in humans (2 mks)

(i) Typhoid

(ii) Amoebic dysentery

(b) Name the disease in humans caused by plasmodium falciparum (1 mk)

10. (a) (i) What is meant by vestigial structures ? (1 mk)

(ii) Give an example of a vestigial structure in human (1 mk)

(b) Explain why certain drugs become ineffective in curing a disease after many years of use.

(2 mks)

11. In an experiment the shoot tip of a young tomato plant was decapitated as shown in the diagram below

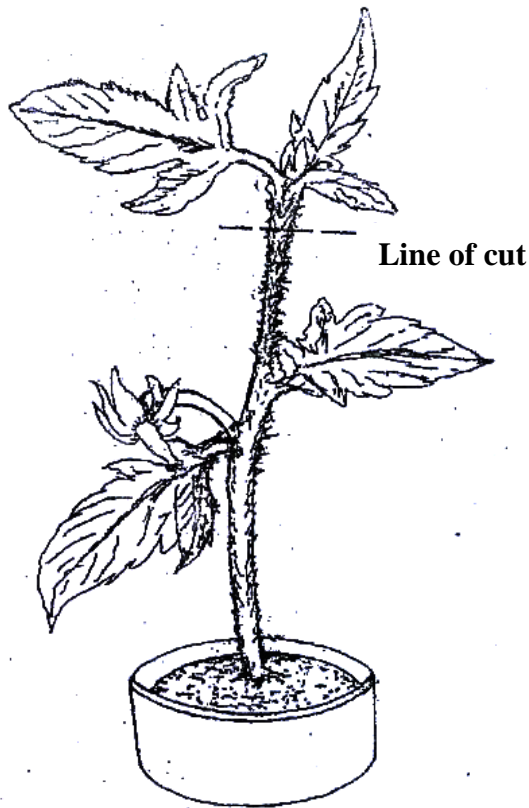

(a) State the expected results after 2 weeks

(1 mk)

(b) Give a reason for your answer in (a) above

(2 mks)

12. The diagram below represents a bone obtained from a mammal

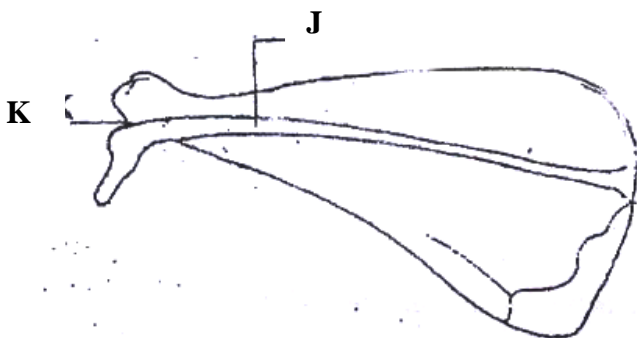

(a) Name the bone

(1 mk)

(b) Name the:

- (i) Bone which articulate with the bone named in (a) above at the cavity labeled K; (1 mk)
- (ii) Joint formed by the two bones (1 mk)
- (c) State the function of the part labeled J (1 mk)
13. (a) Distinguish between diffusion and active transport (2 mks)
- (b) State one role that is played by osmosis in (1 mk)
- (i) Plants
- (ii) Animals
14. Name a support tissue in plants that is not thickened with lignin (1 mk)
15. Name the type of movement that occurs within a plant cell (1 mk)
16. (a) Name the gaseous exchange surface in insects (1 mk)
- (b) How is the surface named in (a) above suited to its function (2 mks)
17. Explain why plants do not require specialized excretory organs (4 mks)
18. Explain how the following factors affect the rate of photosynthesis:
- (a) Concentration of carbon (iv) oxide (1 mk)
- (b) Light intensity (1mk)
19. (a) State three effects of dumping untreated sewage into a river (3 mks)
- (b) Name one process that is responsible for loss of energy from one trophic level to the next (1mk)
20. Other than using the quadratic, give two methods of estimating population of grass (2 mks)
21. Explain what happens in humans when concentration of glucose in the blood decreases below the normal level (4 mks)
22. Explain how the carnassials teeth of a dog are adapted to their function (2 mks)
23. state the function of iron in the human body (1 mk)

24. Explain how the following factors determine the daily energy requirement in human:
- (a) Age (1 mk)
 - (b) Occupation (1 mk)
 - (c) Sex (1 mk)
25. State two ways in which aerenchyma tissues in aquatic plants are adapted to their function (2 mks)
26. How are the mitochondria adapted to their functions? (2 mks)
27. State two ways in which anaerobic respiration is applied in industries (2 mks)
28. (a) State three structural differences between arteries and veins in mammals (3 mks)
- (b) Name a disease that causes thickening and hardening of arteries (1 mk)
29. Explain why the rate of transpiration is reduced when humidity is high

BIOLOGY
K.C.S.E PAPER 231/1 2010
QUESTIONS
PAPER 1

1. State the name give to the study of:

- a) The cell (1 mk)
- b) Micro--organism. (1 mk)

2. The diagram below shows a transverse section of a plant organ.

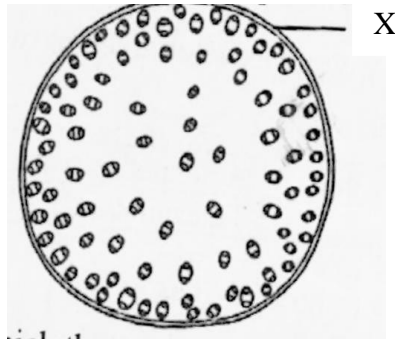

- a) Name the plant organ from which the section was obtained. (1 mk)
- b) i) name the class to which the plant organ was obtained (1 mk)
ii) Give a reason for your answer in (b) (i) above (1 mk)
- c) Name the part labeled X. (1 mk)

3. State the function of:

- a) Ribosomes (1 mk)
- b) Lysosomes (1 mks)

4. The diagram below shows a specialized plant cell.

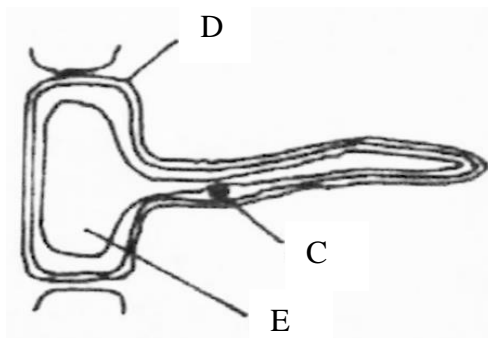

- a) i) Name the cell (1 mk)

- ii) Name the parts labeled **D** and **E**. (2 mks)
- b) State the function of the part labeled **C**. (1 mk)
5. State three ways in which a respiratory surface is adapted to its function. (3 mks)
6. State one function for each of the following:
- a) Cerebellum (1 mk)
- b) Medulla oblongata (1 mk)
7. Distinguish between haemolysis and plasmolysis. (2 mks)
8. State three external differences between chilopoda and diplopoda. (3 mks)
9. State **two** ways in which chloroplasts are adapted to their functions. (2 mks)
10. State two advantages of hybrid vigour. (2 mks)
11. The diagram below shows a transverse section of leaf.

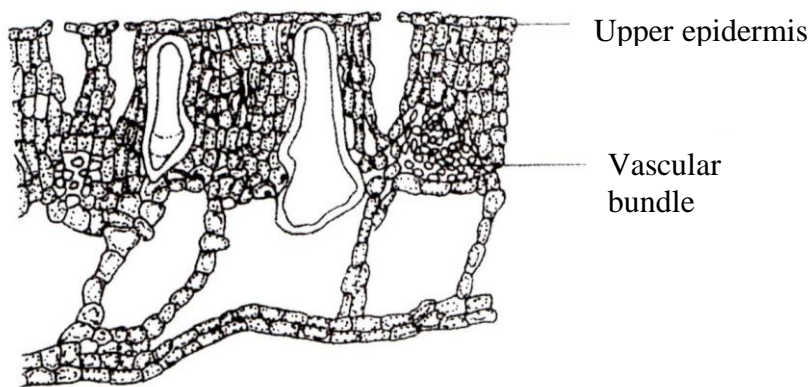

- a) Name the habitat of the plant from which the leaf was obtained. (1 mk)
- b) Give one reason for your answer in (a) above. (2 mks)
12. The diagram below illustrates the structure of bread mould.

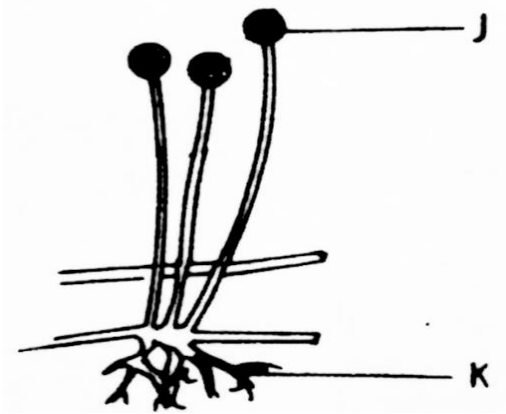

- a) Name the part labeled **J** (1 mk)
 b) State the function of the structure labeled **K** (2 mks)

13. What is meant by the following term?

- a) Habitat; (1 mk)
 b) Ecosystem (1 mk)

14. Explain why is not advisable to be in a poorly ventilated room with a burning charcoal. (3 mks)

15. A potted plant was kept in the dark for 48 hours. Two leaves **X** and **Y** were treated as shown in the diagram below.

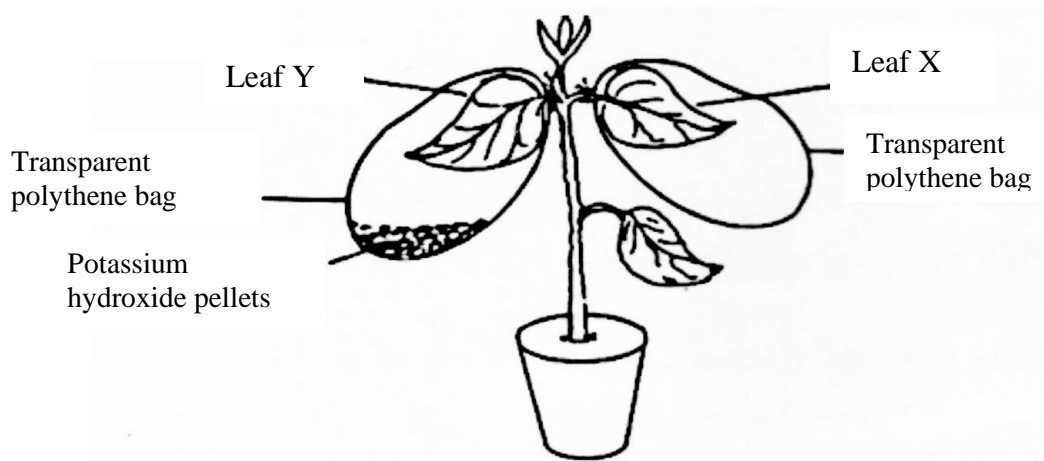

The experimental set-up was kept in sunlight for 6 hours after which a starch test was carried out on the two leaves.

- a) What were the results of the starch test on leaves **X** and **Y**? (2 mks)
 b) Give reasons for your answers in (a) above. (2 mks)

16. What is the role of bile salts in humans? (2 mks)
17. The following is the dental formula of a certain mammal:
 $i \ 0/3 \ c \ 0/1 \ pm \ 3/3 \ m3/3$
- a) State the likely mode of feeding for the mammal. (1 mk)
- b) Give a reason for your answer in (a) above. (1 mk)
18. Give **two** reasons why animals have specialized organ for excretion as compared to plants (2 mks)
19. State the changes that occur in arterioles in the human skin during thermoregulation. (2 mks)
20. State **two** advantages of internal fertilization in humans. (2 mks)
21. The diagram below represents part of the human skeleton.

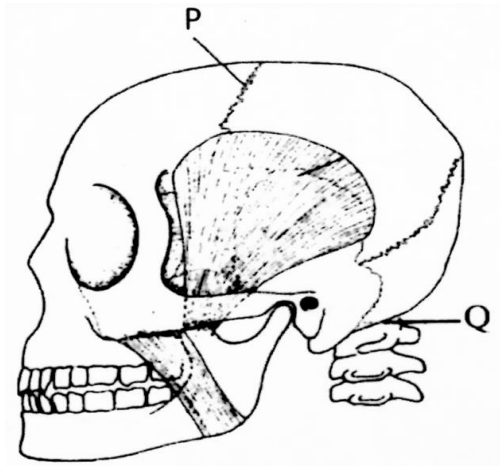

- a) Name the part labeled **P** (1 mk)
- b) i) Name the bone the articulates with the part labeled **Q**. (1 mk)
- ii) What type of joint is formed between the part labeled **Q** and the bone named in (b) (i) above? (1mk)
22. What is the function of the following structure in the human reproductive organ?
- a) Fallopian tubes. (1 mk)
- b) Epididymis. (1 mk)
- c) Scrotl sac (1 mk)

23. Explain **three** ways in which red blood cells are adapted to their function. (3 mks)

24. .

a) State **two** ideas proposed by Lamk in his theory of evolution. (2 mks)

b) Why is Larmk's theory not acceptable? (1 mk)

25. State **three** factors that contribute to the deceleration phase in the population curve of an organism (1 mk)

26. State **one** survival value for each of the following in plants:

a) Thigmotropism in stems; (1 mk)

b) Geotropism in roots. (1 mk)

27. .

a) What is meant by the term non-disjunction? (1 mk)

b) Give an example of a genetic disorder caused by:

i) Non-disjunction; (1 mk)

ii) Gene mutation (1 mk)

28. State **three** structural differences between arteries and veins. (3 mks)

29. The diagram below represents a female cone.



a) Name the subdivision of the plant from which the cone was obtained. (1 mk)

b) Other than the presence of cone, name **two** other external features that identify plants in the subdivision named in (a) above. (2 mks)

20. What is meant by the apical dominance? (3 mks)

BIOLOGY

K.C.S.E PAPER 231/1 2011

QUESTIONS

1. Name two kidney diseases. (2mks)

2. (a) Write the dental formula of an adult human. (1mk)
3. Give three reasons for classifying organisms. (2mks)

4. State one use for each of the following apparatus in the study of living organisms.
 - (a) Pooter
 - (b) Pitfall trap (2mks)

5. The figure below illustrates a food web in a certain ecosystem.

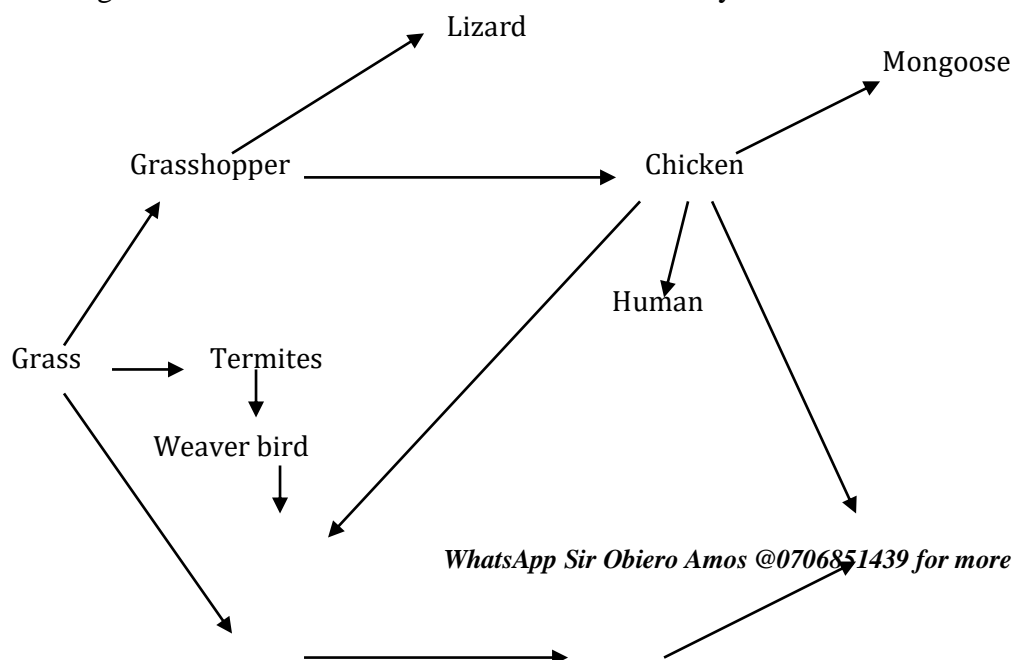

Hawk

Vulture

Sheep

Hyena

From the food web:

From the food web:

(a) Draw the shortest food chain; (1mk)

(b) identify the organisms with the highest

(i) Number of predators (1mk)

(ii) Biomass (1mk)

6. What is meant by the following terms?

(a) Ecology (1mk)

(b) Carrying capacity (1mk)

7. The diagrams below show an experiment set up to investigate a certain process in a plant tissue.

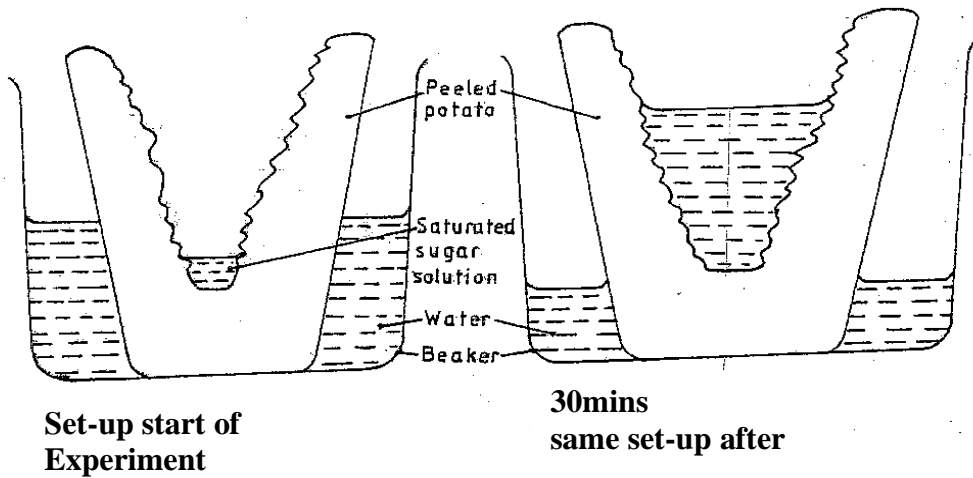

Explain the results obtained after 30 min. (4mks)

8. State three characteristics of the class crustacean. (3mks)

9. The diagrams below illustrate the organs of some flowering plants.

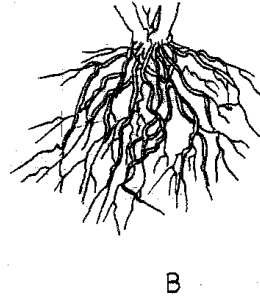
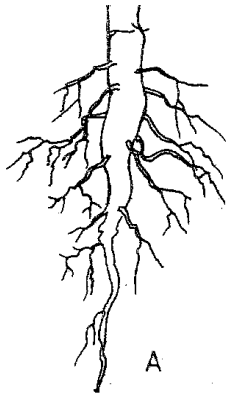

State the classes of plants to which each belong.

(2mks)

A

B

10. (a) give two differences in the products of anaerobic respiration between plants and animals.

(2mks)

(b) Name the site of anaerobic respiration in a cell.

(1mk)

11. State two functions of the following parts of a light microscope.

(2mks)

Fine adjustment knob

Stage

12. The diagram below represents a certain organism.

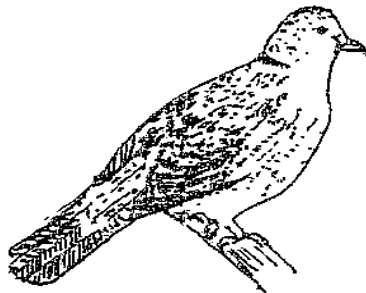

State the phylum and class of carbohydrates in the human body.

(2mks)

14. The diagram below represents a certain plan.

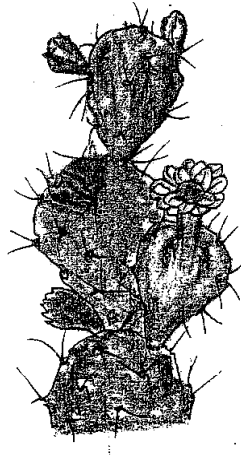

(a) What is the likely habitat of the plant? (1 mk)

(b) Give two reasons for your answer in (a) above. (2 mks)

15. Give reasons for carrying out the following procedures when preparing temporary wet mounts of plant tissues.

(a) Making thin plant sections (1 mk)

(b) Adding water on the plant section. (1 mk)

16. (a) describe the condition known as varicose veins. (2 mks)

(b) What is the role of blood platelets in the clotting process? (2 mks)

17. The diagram represents part of the human digestive system.

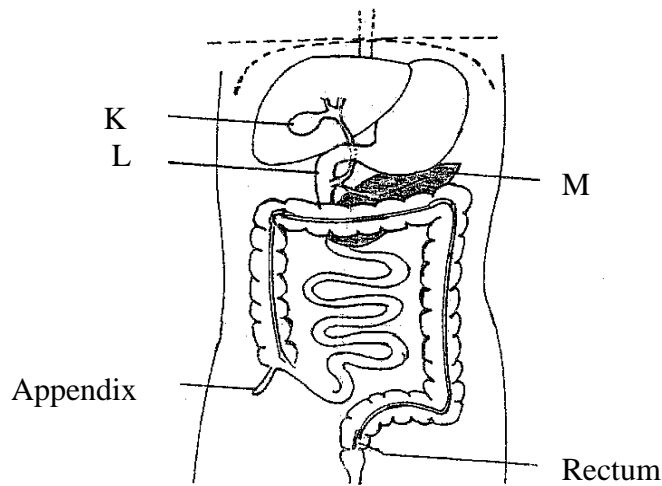

(a) Name the organs labeled L and M. (2 mks)

L

M

(b) (i) Name the substance named in b (i) above. (1 mk)

19. (a) Apart from the lungs, name two gaseous exchange surfaces in a frog. (2 mks)

(b) Write an equation that summarizes the process of aerobic respiration. (2 mks)

20. The number of stomata on the lower and upper surface of two leaves from plant **X** and **Y** were counted under the field of view of a light microscope. The results were as shown in the table below.

Leaf	Number of stomata	
	Upper surface	Lower surface
X	4	12
Y	20	23

(a) Which of the leaves would be expected to have a lower rate of transpiration? (1 mk)

(b) Given a reason for your answer in (a) above (1 mk)

21. (a) what is meant by convergent evolution? (1 mk)

(b) State **two** limitations of fossils as an evidence of evolution. (2 mks)

22. State the difference in content of oxygen and carbon (IV) oxide in the air that enters and leaves the human lung. (2 mks)

23. The diagram below represents a transverse section of an ovary from a certain flower.

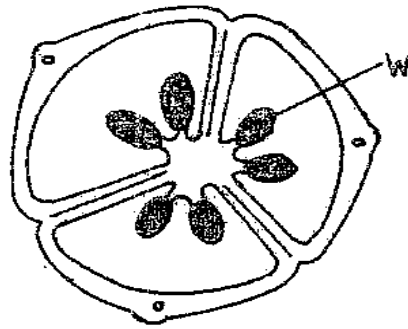

(a) (i) name the structure labeled W (1 mk)

(ii) name the type of plantation illustrated in this diagram. (1 mk)

(b) Give an example of a plant whose flowers have the type of placentation named in (a) (ii) above (1 mk)

24. (a) Difference between the following terms:

(i) dominant gene and recessive gene; (1 mk)

(ii) continuous variation and discontinuous variation (1 mk)

(b) What would be the expected results from a test cross? (2 mks)

25. State one economic importance of each of the following plant excretory products. (2 mks)

(a) Tannin

(b) Quinine

(c) Caffeine

26. Name the gamete cells that are produced by the ovaries. (1 mk)

27. The diagram below represents features of a joint mammal.

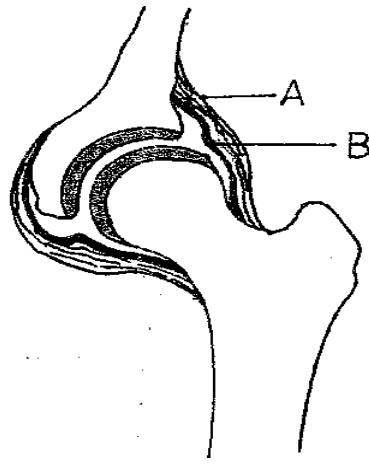

- (a) Name the part labeled A (1 mk)
(b) State the function of the part labeled B (1 mk)

28. (a) What is a tropic response? (1 mk)

(b) State **two** ways by which auxins regulate growth in seedlings (1 mk)

29. State **four** reasons why water is significant in seed germination (2 mks)

BIOLOGY
K.C.S.E PAPER 231/1 2012
QUESTIONS

1. How does nutrition as a characteristic of living organisms differ in plants and animals? (2 mks)
2. The diagram below represents a certain organism collected by a student at the sea shore.

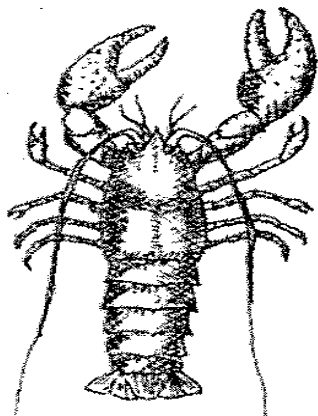

- (a) Name the class to which the organism belongs.
- (b) Give three reasons for your answer in (a) above.
2. The figure below is a fine structure of a generalised animal cell as seen under an electron microscope.

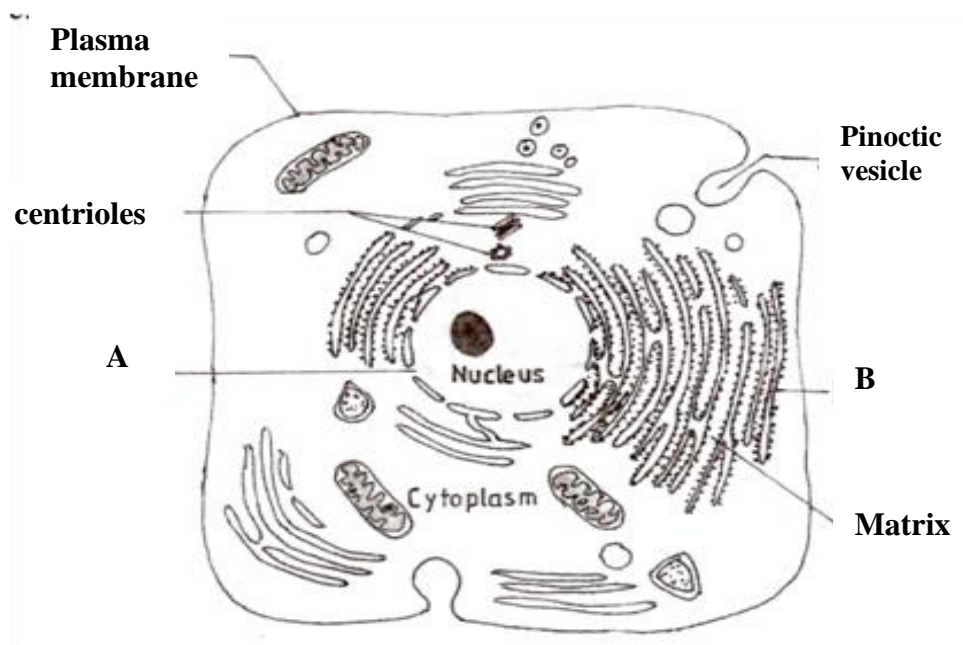

- (a) Name the parts labelled A and B. (2mks)

A.....

B

- (b) How is the structure labelled B adapted to its function? (2mks)

4. In an investigation, a student extracted three pieces of paw paw cylinders using a cut back to 50 mm length and placed in a beaker containing a solution. The results in the table below. (3 mks)

Feature	Result
Average length of cylinders (mm)	56 mm
Stiffness of cylinders	stiff

- (a) Account for the results in the table above. (3 mks)

- (b) What would be a suitable control set-up for the investigation? (2 mks)

5. The table below shows results of a study of three plants C, D and E growing in different (1 mk)

Feature	Plant C	Plant D	Plant E
Number of stomata on upper surface of leaf per square area	4	20	6
Number of stomata on lower surface of leaf per square area	6	0	8
Thickness of leaf cuticle (mm)	0.4	0.1	0.2
Surface area of roots (cm ⁻¹)	2000	1000	1200

- (a) Which one of the plants C, D and E grows in an area of relatively low water availability?

- (b) Explain your answer in (i) above.

6. The diagram below represents part of the gaseous exchange system in human. (2 mks)

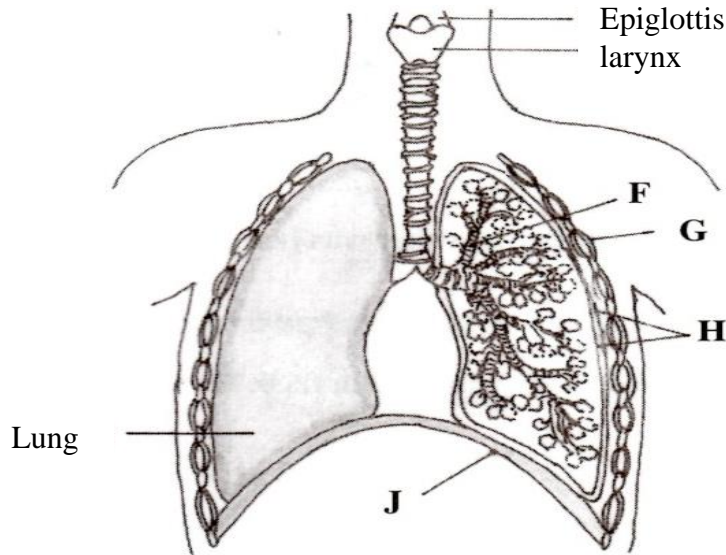

- (a) Name **the parts** labelled F and G.
 F.....
 G.....
- (b) State one function of each of the parts labelled H and J.
 H.....
 J.....

7. .The diagram below represents a set-up that students used in an investigation.

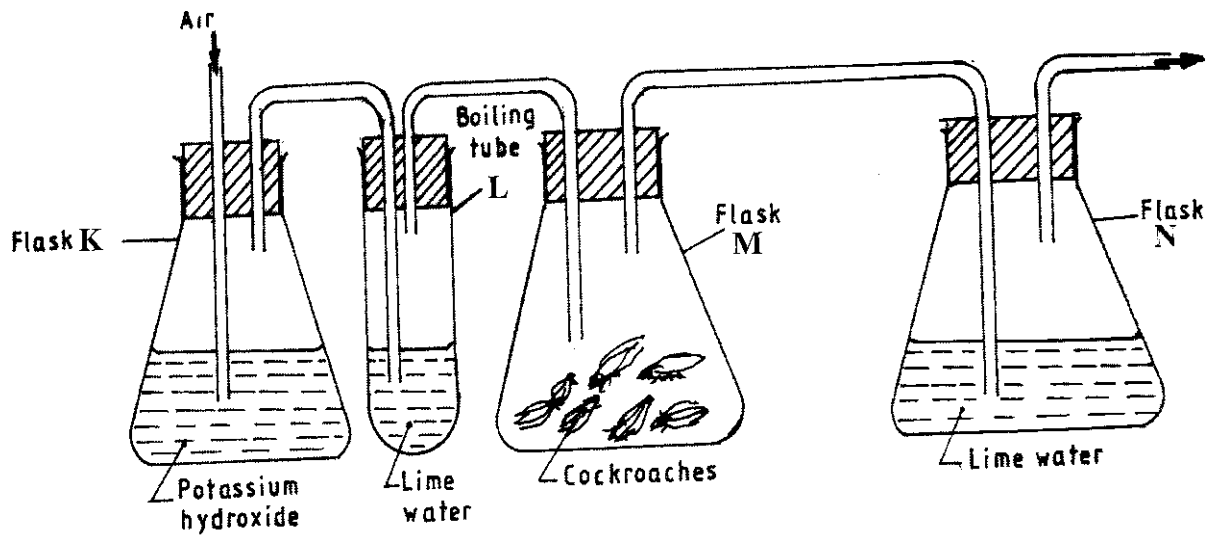

- a) Name the physiological process that was being investigated. (1 mk)
- b) State the role of potassium hydroxide in flask K. (1 mk)

(c) Account for the observation in boiling tube L and flask N. (2 mks)
L.....
N.....

8. What is the probability of a couple with blood group AB getting a child with blood group AB? Show your working. (4 mks)

9 State the importance of negative phototaxis to termites. (1 mk)

10 What is meant by the term irritability? (1 mk)

11. (a) State two ways in which heart muscles are special. (2 mks)

(b) Name the muscles found in the following organs; (2 mks)

Stomach;

bone.....

12 (a) Name the part of a light microscope used to bring an image of a specimen into sharp focus. (1 mk)

(b) Why is it recommended to keep the stage of the microscope dry? (1 mk)

13. State **three** factors that affect the rate of diffusion. (3 mks)

14. (a) Name the type of respiration that is most efficient. (1 mk)

(b) Give a reason for your answer in (a) above (1mks)

15. What name is given to a group of hormones that controls the development of secondary sexual characteristics in a human male? (1 mk)

16. The diagram below represents an experimental set-up used by students to investigate a certain process.

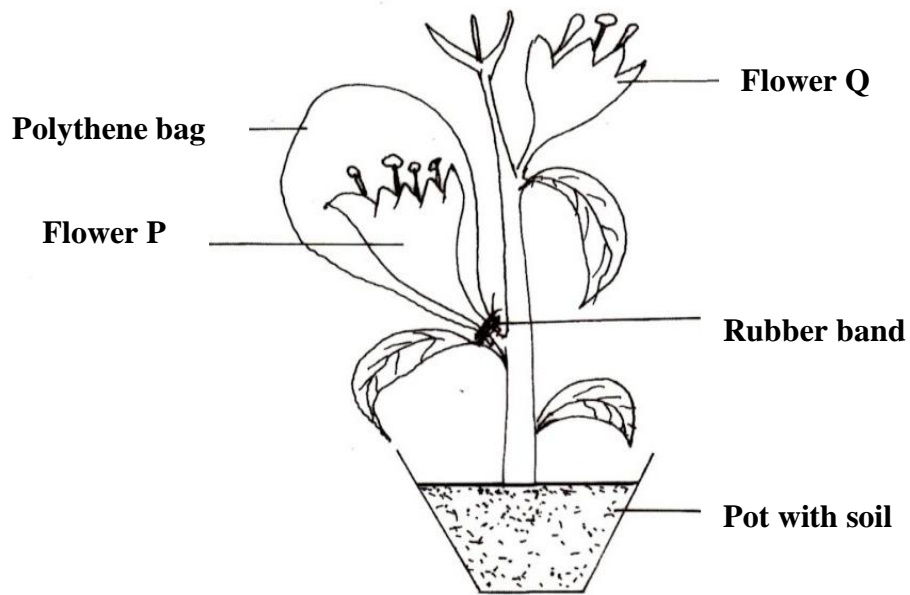

Flower Q produced seeds while P did not. Account for the results.

17. Name two substances that leave the foetal blood through the placenta. (2 mks)
18. Why are plants able to accumulate most of their waste products for long? (1 mk)
19. List **four** symptoms of diabetes mellitus. (4 mks)
20. State **three** aspects that can be used to estimate growth in seedlings. (3 mks)
21. Name the process through which free atmospheric nitrogen is converted into nitrates. (1 mk)
22. State the importance of divergent evolution to organisms. (2 mks)
23. Name the strengthening materials found in the following support tissues: (2 mks)
- (a) collenchyma;.....
- (b) xylem.....
24. State four characteristics of apical meristem cells. (4 mks)

25. State the role of the following hormones in the life cycle of insects: (2 mks)
ecdysone hormone;
juvenile hormone.....

26 (a) State the theories of evolution proposed by the following scientists. (2 mks)
Darwin.....
Jean-Baptiste Lamarck.....

(b) State the evidence of evolution based on Cell
(i) organelles.....
.....
(ii) fossils.....

27. What is the function of contractile vacuoles in amoeba? (1mk)

28. state two differences between open and closed circulatory systems. (2 mks)

29. Name two nutrients that are absorbed without being digested by enzymes in humans. (2 mks)

30. Name the organelle that is involved in each of the following: (2 mks)
(a) manufacture of lipids
(b) formation of lysosomes

BIOLOGY
K.C.S.E PAPER 231/1 2013
QUESTIONS

1. (a) What is meant by the term wilting? (1 mk)
(b) Explain how an increase in temperature affects the rate of active transport? (2 mks)

2. The diagram represents a cell as seen under an electron microscope.

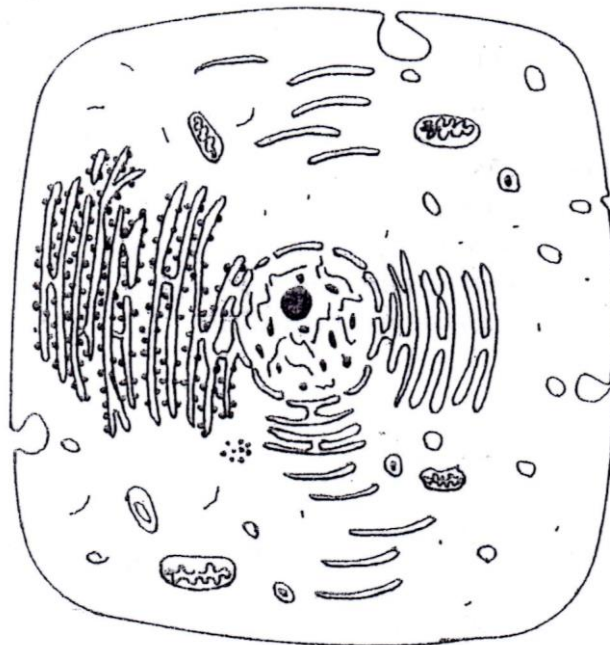

- (a) Based on the diagram, state whether it represents an animal cell or a plant cell. (1 mk)
(b) Give two reasons for your answer in 2(a) above. (2 mks)
(c) Why is the palisade layer a tissue? (1 mk)

3. (a) State two external features found in the class Mammalia only. (2 mks)
(b) Name the taxonomic unit that comes immediately after a phylum in classification. (1 mk)

4. (a) State two roles of mucus in the stomach. (2 mks)
(b) Explain how age determines a person's energy requirements. (2 mks)

5. Describe how turgor pressure builds up? (3 mks)
6. Using a microscope, a student counted 55 cells across a field of view whose diameter was 6000 μ m. Calculate the average length of the cells. Show your working. (2 mks)
7. Explain how the following forces contribute to the movement of water up the xylem vessels: (2 mks)
 (a) cohesion;
 (b) adhesion;
8. Construct a step in a dichotomous key using two leaves one with a serrated and the other with a smooth margin. (2 mks)
9. State one way in which each of the following is structurally adapted to its function:
 (a) neurone; (2 mks)
 (b) mitochondrion; (2 mks)
10. How are lenticels adapted for gaseous exchange? (2 mks)
11. State the advantage of possessing blood group AB. (1 mk)
12. (a) A student collected an organism and observed the following features: simple eyes, four pairs of legs and two body parts.
 (i) State the class to which the organism belongs. (1 mk)
 (ii) Give an example of an organism in this class. (1 mk)
 (b) Name the kingdom to which plasmodium belongs. (1 mk)
13. State two characteristics of living organisms that are specific to plants. (2 mks)
14. Name three end products of anaerobic respiration in plants. (3 mks)
15. State two reasons why accumulation of lactic acid leads to an increase in heart beat. (2 mks)
16. Name three mechanisms that ensure cross pollination takes place in

flowering plants. (3 mks)

17. Name the flower part that produces gametes. (1 mk)

18. How is the human sperm cell structurally specialized? (2 mks)

19. State three factors in seeds that cause dormancy. (3 mks)

20. Explain the theory of evolution by natural selection. (2 mks)

21. (a) Explain the role of continental drift in evolution. (3 mks)

(b) What is meant by the term organic evolution? (1 mk)

22. The diagram below illustrates a response by a certain plant.



(a) Name the type of response. (1 mk)

(b) Explain how the response illustrated above occurs. (3 mks)

23. The diagram below illustrates a defect in the eye.

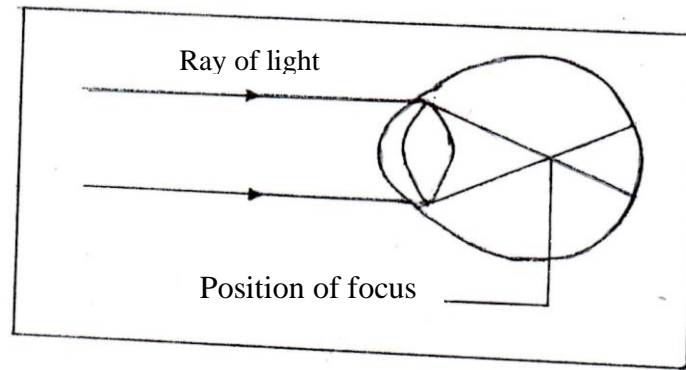

- Explain how the defect illustrated above can be corrected. (2 mks)
24. Explain three protective functions of mammalian blood. (3 mks)
25. State one adaptation of xylem vessels to their function. (2 mks)
26. (a) What is meant by the term sex linked genes? (1 mk)
- (b) Name two sex linked traits in human beings. (2 mks)
27. (a) State two differences between complete and incomplete metamorphosis. (2 mks)
- (b) State the importance of moulting to an insect. (1 mk)
28. (a) State two features of a ball and socket joint. (2 mks)
- (b) Name the bone that allows the head to;
- (i) nod; (2 mks)
- (ii) turn side ways;
29. State two functions of pelvic girdle in mammals. (2 mks)
30. State two ways in which osmosis is significant to plants. (2 mks)

BIOLOGY
K.C.S.E PAPER 231/1 2014
QUESTIONS

Answer all the questions

1. State the importance of each of the following in living organisms: (1 mk)
 - (a) Nutrition (1 mk)
 - (b) Excretion. (1 mk)
2. (a) What is meant by the term seed dormancy? (1 mk)
(b) State **three** causes of seed dormancy (3 mks)
3. State **two** functions of the placenta in mammals. (2 mks)
4. The diagram below illustrates a growing pollen tube

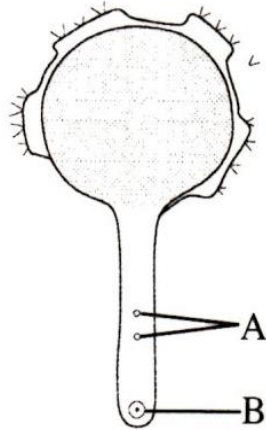

- a) Name the part labeled **B** (1 mk)
- b) Explain the role of the parts labeled **A**. (2 mks)

5. The diagram below shows a set up for an experiment to demonstrate a certain physiological process.

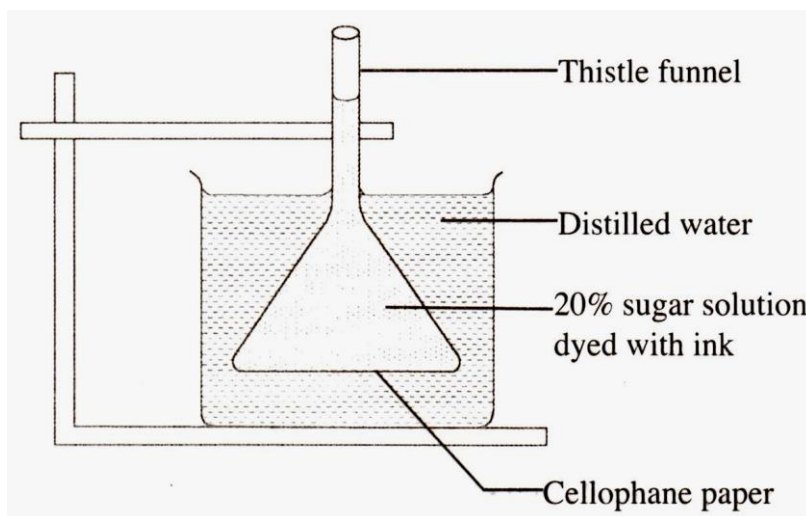

- a) What nature of solution is represented by 20% sugar solution? (1 mk)
- b) Explain the observation made on the set up after one hour. (2 mks)
6. State **three** roles of auxins in a plant stem. (3 mks)
7. A student drew a 6mm long diagram of a plant flower. If the actual length of the flower was 12cm, calculate the magnification of the drawing made by the student. Show your workings (2 mks)
8. Differentiate between phenotype and genotype as used in genetics (1 mk)
9. State **two** functions of intervertebral discs in the mammalian skeleton. (2 mks)
10. (a) Explain **two** roles of diffusion in human (4 mks)
- (b) What is meant by each of the following terms?
- i) Crenated cell. (1 mk)
- ii) Flaccid cell (1 mk)
11. State **three** differences between tactic and tropic responses (3 mks)

Tactic Responses	Tropic Responses

12. The diagram below represents a model used to demonstrate breathing in mammals

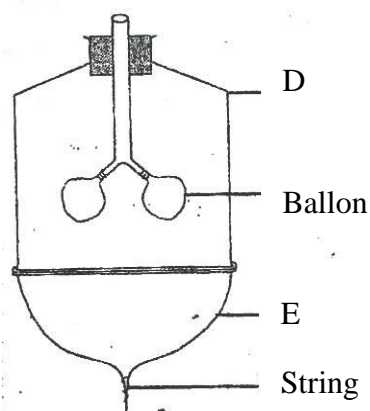

- a) Name the mammalian structure represented by the parts labeled D and E.
 (i) **D** (1 mk)
 (ii) **E** (1 mk)
 b) Explain the observation made when the string is pulled downwards. (1 mk)
 c) Explain the observation in (b) above (2 mks)

13. State **one** function of each of the following parts of a mammalian eye;
 (a) Eye lashes (1 mk)
 (b) Lachrymal glands (1 mk)

14. State **three** structural differences between DNA and RNA (3 mks)

DNA	RNA

15. a) Which type of mammalian muscles is voluntary? (1 mk)
 b) Distinguish between a tendon and a ligament. (1 mk)

16. The diagram below illustrates a nerve cell.

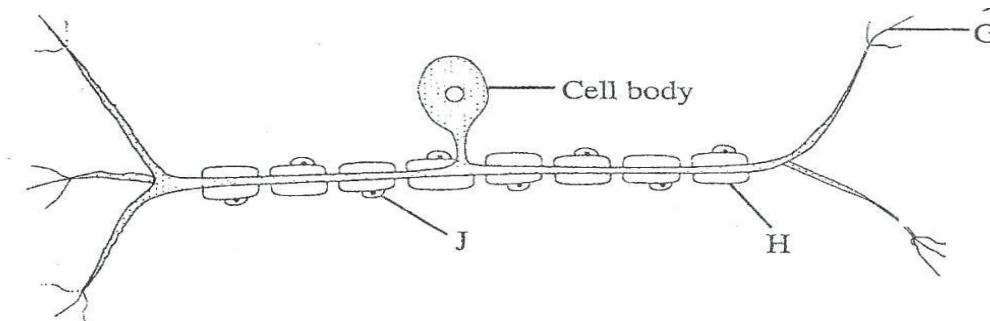

- a) Name the type of nerve cell illustrated. (1 mk)
 b) Give a reason for your answer in (a) above (1 mk)
 c) Identify the part labeled **J** (1 mk)
 d) State **one** function of each of the parts labeled **G** and **H**.
 (i) **G** (1 mk)
 (ii) **H** (1 mk)
17. Give a reason why the image is not formed when light is focused on the blind spot. (1 mk)

18. Explain why
- a) Mammalian testes are located to hang outside the body (2 mks)
 - b) Four months after fertilization, ovaries can be removed from a human female, without terminating pregnancy (2 mks)
19. Why is a burning charcoal stove in a poorly ventilated room likely to cause death of the inhabitants? (3 mks)
20. State **one** function of each of the following cell organelles:
- a) Golgi bodies (1 mk)
 - b) Lysosomes. (1 mk)
21. Name the type of skeleton that makes up each of the following animals
- (a) Locust. (1 mk)
 - (b) Bird . (1 mk)
22. (a) Name **two** vestigial structures in human beings (2 mks)
- (b) Why are some bacterial able to resist the effect of antibiotics? (2 mks)
23. Below is an illustration of a cross section of a plant root showing the transportation of substances in the plant.

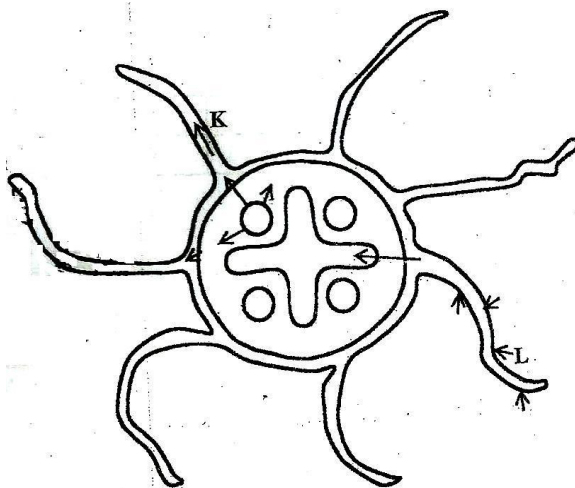

(a) Name the substances transported along the paths labeled **K** and **L**.

K (1 mk)
L (1 mk)

(b) Give a reason for your answer in **L** above. (1 mk)

24. The table provided shows the transportation of substance in the human body.

substance	Transported by blood	
	From	To
Oxygen	M	Whole body
N	Liver	Kidneys
P	Intestine	Whole body

Name the substances represented by

M (1 mk)
N (1 mk)
P (1 mk)

25. State **two** roles of luteinising hormones in human reproduction. (2 mks)

26. The table provided show the concentration of sodium and iodine in sea water and cell sap of a plant.

	Sodium ion concentration	Iodine concentration
sea Water	250	35
cell sap	100	550

a) (i) Name the process through which the plant cells take up sodium ions. (1 mk)

ii) Give a reason for your answer in (a) (i) above (1 mk)

- b) If the plant was sprayed with a chemical that inhibits respiration:
- Which of the two ions uptake will be affected? (1 mk)
 - Give a reason for your answer in (b) (i) above (1 mk)

27. The diagram below shows the gaseous exchange system of a locust.

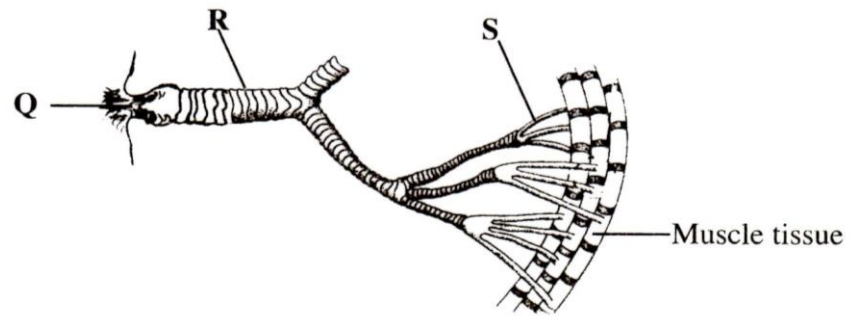

- Name the structure labelled **Q**. (1 mk)
- State the function of the part labelled **R**. (1 mk)
- How is the part labelled **S** structurally adapted to its function? (1 mk)

BIOLOGY
K.C.S.E PAPER 231/1 2015
QUESTIONS

Answer all the questions in the spaces provided.

1. (a) What is meant by the term binomial nomenclature? (2mks)
- (b) State two guidelines that should be followed when typing scientific names. (2 mks)
2. During a lesson, students observed the structure of bat, cat and human forelimbs to determine their evolutionary relationship.
 - (a) State the name given to the structure of the limbs observed by the students. (1 mk)
 - (a) Name the type of evolution illustrated by the structure of the limbs observed (1mk)
 - (b) What evidence of evolution is illustrated by the limbs? (1mk)
 - (c) State the significance of the type of evolution illustrated by the limbs (1mk)
3. An individual is of blood group B positive
 - a) Name the antigens in the individual's blood (2mks)
 - b) Give the reason why the individual cannot receive blood from a blood group A donor. (2mks)
4. Colour blindness is a sex linked trait controlled by a recessive gene b. If a mother is a carrier and the father is normal, what is the chance that their

son will be colour blind? Show your working. (4 mks)

5. (a) State two advantages of using a coverslip when preparing a specimen for observation under a light microscope. (2 mks)

(b) How is the low power objective lens manipulated to focus a specimen for observation under a light microscope? (2 mks)

6. Students set up an experiment as illustrated below.

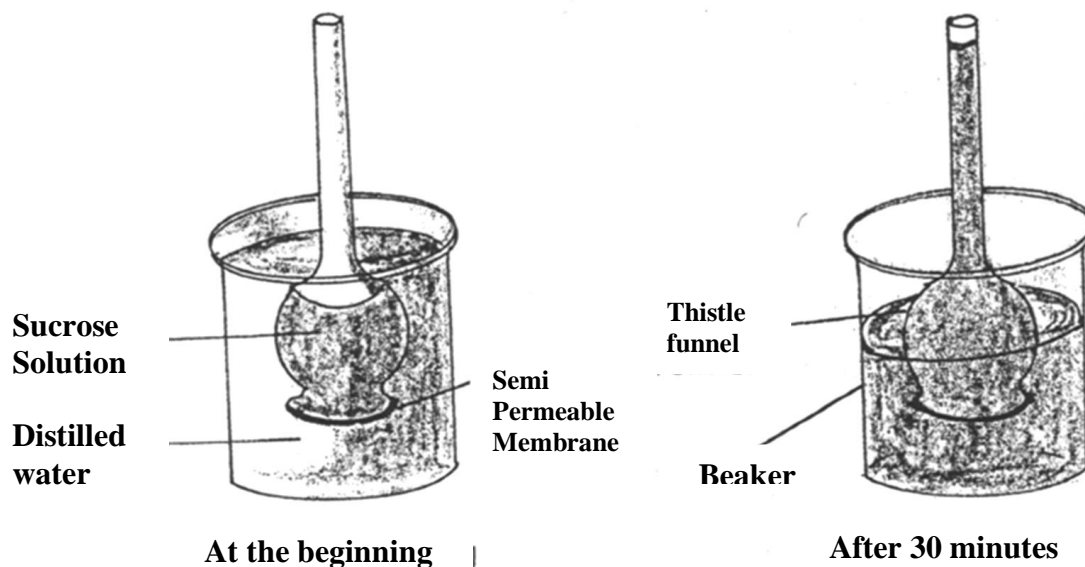

(a) Name the physiological process that resulted in the observations made after 30 minutes. (1 mk)

(b) State the importance of the physiological process investigated in plants. (1 mk)

(c) Explain the observations made after 30 minutes. (2mks)

7. How is a guard cell structurally adapted for gaseous exchange? (4 mks)

8. a) Name the organism that:

i) Causes malaria (1mk)

ii) Transmits malaria (1mk)

b) State two control measures for malaria

(2mks)

9. The diagram below shows an experimental set up to investigate a certain physiological process in plants.

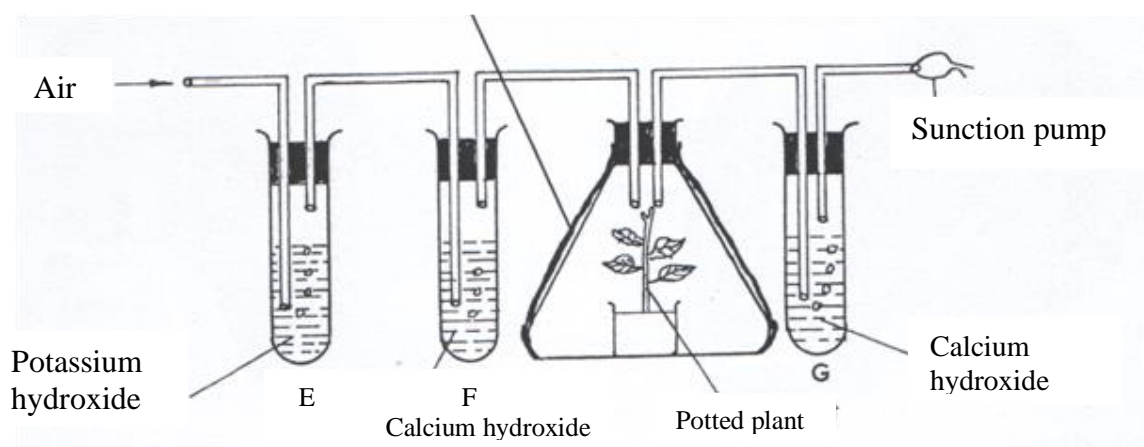

a) State the aim of the experiment

(1mk)

b) State the role of the following in the experiment:

i. Potassium hydroxide

(1mk)

ii. Aluminium foil

(1mk)

c) Account for the expected colour change in tube F

(2mks)

10. The diagram below illustrates the skulls of adult human and chimpanzee

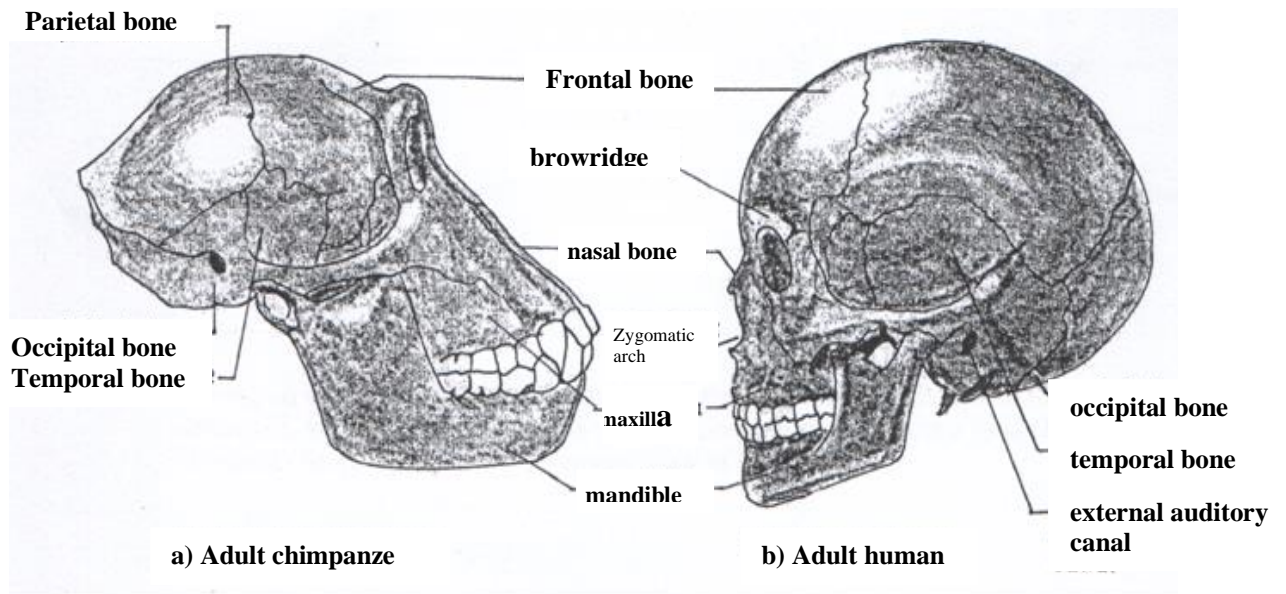

a) State one difference between the two skulls in the following structures (3mks)

	Structure	Chimpanzee skull	Human skull
i	Parietal bones		
ii	Mandible		
iii	Browridge		

b) State the significance of the evolution observed on the parietal bone in the chimpanzee and human skulls. (1mk)

11. Name two structures used for gaseous exchange in plants (2mks)

12. a) What is meant by each of the following:
- i. Pyramid of biomass? (1mk)
 - ii. Pyramid of numbers? (1mk)
- b) During an ecological visit to the savanna grassland, students were able to see lions, antelopes, vultures and pastoralists grazing their cattle. Construct a food chain with four counmder levels to illustrate the energy flow in the ecosystem. (2mks)
13. State three differences between the end products of mitosis and meiosis. (3mks)
- | | |
|---------|---------|
| Mitosis | Meiosis |
|---------|---------|
14. a) Name two types of involuntary in mammals (2mks)
- b) State the location of each of the muscles named in (a) above (2 mks)
15. The photomicrographs below shows the various stages of cell division in a certain plant.

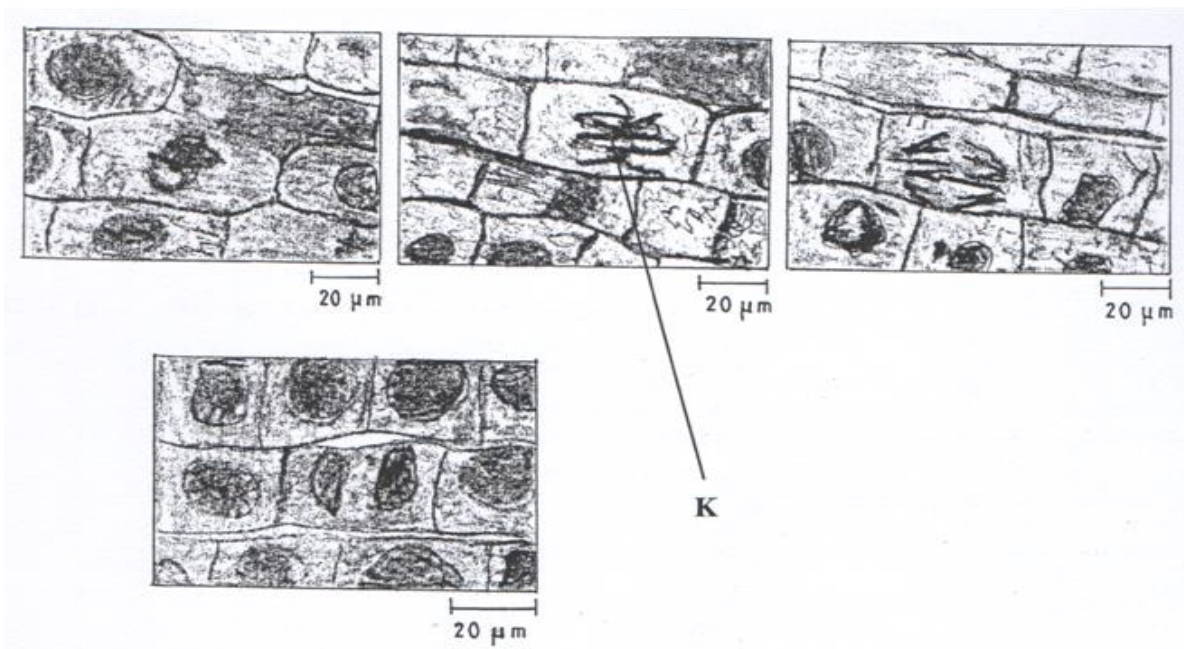

- (a) (i) Name the type of cell division illustrated (1mk)
 (ii) Give a reason for your answer in (a) (i) above (1mk)
- (b) (i) Name the stage of cell division labeled K. (1mk)
 (ii) Give a reason for your answer in (b) (i) above (1mk)

16. State four structural differences millipedes and centipedes (4mks)

Millipedes

Centipedes

17. a) How is a human stomach adapted to

- i. Protein digestion? (2mks)
 ii. Churning? (2mks)
- b) What happens to the glucose synthesized during photosynthesis? (2mks)

18. The diagram below shows an experimental set-up to investigate the conditions necessary for germination. Test tube P was placed in a refrigerator while Q was left at room temperature. The set-ups were observed regularly for two weeks but no germination occurred.

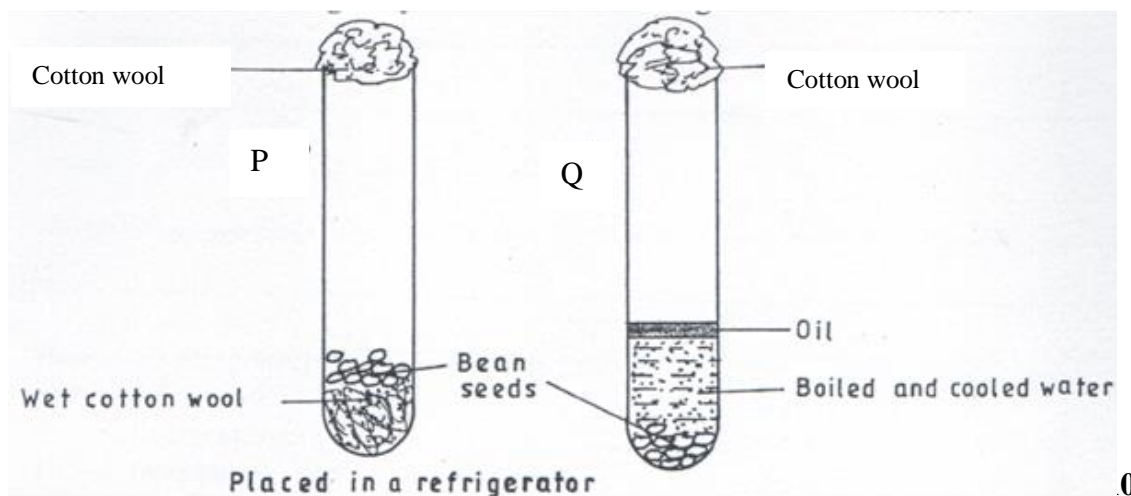

Wet cotton wool

Bean
seeds

Boiled and cooled water

Placed in a refrigerator

Explain the observations in P and Q.

P (2mks)

Q (3mks)

19. a) Using the axes provided below, sketch a curve to illustrate the growth pattern observed in the phylum arthropoda. (2mks)

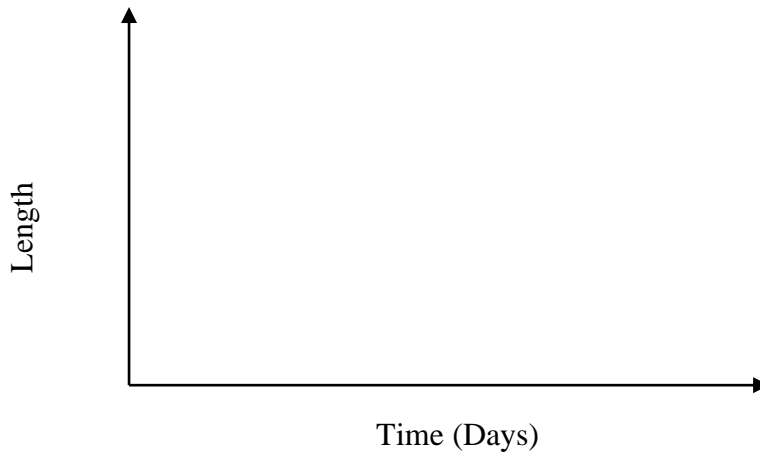

b) Explain the growth pattern observed in arthropods (3mks)

20. Below are components of a simple reflex pathway:

- Interneurone
- Muscle
- Motor neurone
- sensory neurone
- pain receptor
- central nervous system

List the components in their proper sequence during the transmission of a nerve impulse (3mks)

BIOLOGY
K.C.S.E PAPER 231/1 2016
QUESTIONS

Answer all the questions in the spaces provided.

1. (a) State **two** ways in which the muscles of the mammalian heart are special. (2 mks)
b) Name the type of muscles found in the following organs (2mks)
2. Why are plants able to accumulate most of their waste products for long? (2mks)
3. State the importance of tactic responses among members of Kingdom Protista (2mks)
4. a) Name one defect of the circulatory system in humans (1 mk)
b) State three functions of blood other than transport (3 mks)
5. State the Economic importance of anaerobic respiration in plant (1 mk)
6. Explain continental drift as evidence of evolution (3mks)
7. Explain how the following prevent self pollination
i) Protandry (1 mk)
ii) Self sterility (1 mk)
8. State three functions of Golgi apparatus (3 mks)
9. a) Name two structures of gaseous exchange in aquatic plants (2 mks)
b) What is the effect of contraction of the diaphragm muscles during breathing in mammals (3mks)
10. a) State two advantages of sexual reproduction in animals (2mks)
b) State two functions of a placenta (2 mks)
11. Name two benefits that a parasite derives from its host. (2 mks)
12. Other than using a quadrat give two methods that can be used to estimate the

- population of grass (2 mks)
13. a) State two factors that affect enzymatic activities (2 mks)
 b) Explain how one of the factors stated in (a) above affects enzymatic activities (1mk)
14. Give three factors that determine the amount of energy a human being requires in a day (3 mks)
- 15.a)What is seed dormancy? (1mk)
 b)Name a growth inhibitor in seeds (1mk)
16. State one use of each of the following excretory products of plants (2mks)
 i) Colchicine
 ii) Papain
17. State the name given to the study of
 i)The cell (1 mk)
 ii)Micro-organism (1mk)
18. Distinguish between haemolysis and plasmolysis (2mks)
19. Explain why it is not advisable to be in a poorly ventilated room with a burning charcoal stove (3 mks)
20. State three factors that contribute to the deceleration phase in the population curve of an organism (3 mks)

21. The figure below illustrates a food web in a certain ecosystem

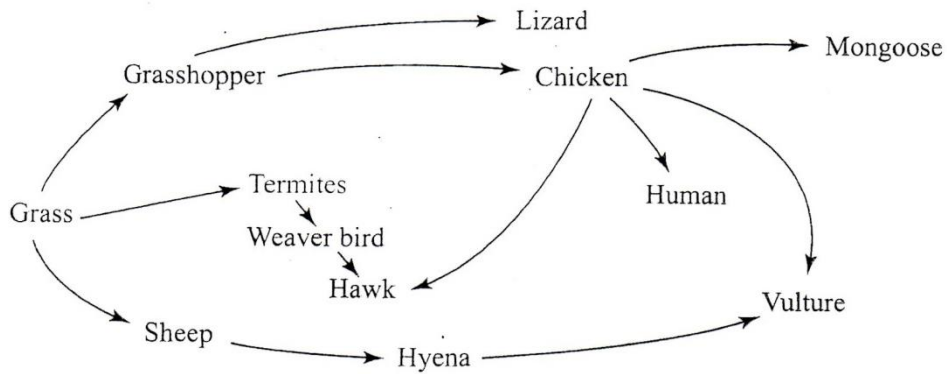

From the food web

- a) Draw the shortest food chain (1 mk)
- b) Identify the organism with the highest
 - i) Number of predators (1 mk)
 - ii) Biomass (1 mk)

22. State three characteristics of the class Crustacea (3mks)

23a) Name one salivary gland in humans (1 mk)

b) State two functions of saliva (2 mks)

24. How does nutrition as a characteristic of living organisms differ in plants and animals (2 mks)

25. Distinguish between diffusion and osmosis. (2 mks)

26. State the functions of the following parts of a microscope (2 mks)

a)Objective lens

b)Diaphragm

27.a)What is single circulatory system? (1mk)

b) Name an organism which has a single circulatory system (1mk)

c) Name the opening to the chamber of the heart of an insect (1mk)

28. The diagram below shows a transverse section of a plant organ

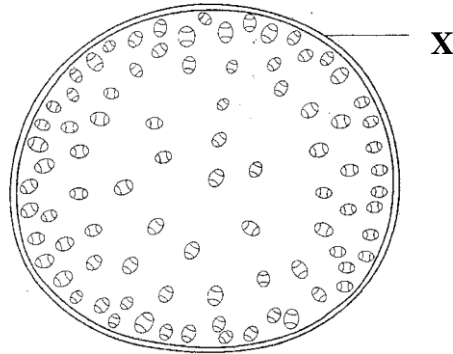

a)Name the plant organ form which the section was obtained (1 mk)

b) i)Name the class to which the organism form which section as obtained belongs (1 mk)

ii)Give a reason for your answer in b(i) above (1 mk)

29. a) State a characteristic that is common to all cervical vertebrae (1 mk)

b) Name two tissue s in plants that provide mechanical support (2 mks)

30. State two advantages of hybrid vigour (2 mks)