

# KCSE MADE FAMILIAR

## BIOLOGY

**Topically Analysed KCSE past Questions**

**For Marking Schemes Call 0705525657**

### **TOPICS HIGHLIGHTED**

1. Classification I & II.....4
2. The cell – structure & functions of organelles.....5
3. Cell physiology – osmosis, diffusion and active transport.....9
4. Nutrition in (a) plants (b) animals.....13
5. Transport in (a) plants (b) animals.....24
6. Gaseous exchange in (a) plants (b) animals.....30

**7. Respiration.....34**

**8. Excretion and homeostasis.....37**

**9. Ecology.....45**

**10.     Reproduction in (a) plants   (b) animals.....53**

**11. Growth and development in (a) plants   (b) animals.....61**

**12.Genetics.....68**

**13.Evolution.....75**

**14.     Irritability and sensitivity in (a) plants   (b) animals.....77**

**15.     Support and movement in (a) plants   (b) animals.....82**

**16. Human health.....85.**

## SECTION I & II QUESTIONS

- *This section deals with paper one and two questions. In paper one you will find simple questions requiring simple answers, single answer and/or a sentence.*
- *In paper two structured data based questions and essay questions.*

# 1. Classification I & II

1. Name **two** classes of phylum arthropoda with cephalothorax.
2. List any **three** distinguishing features of class mammalia.
3. Give **two** characteristics that distinguish scientific names of organisms from the ordinary names
4. (a) In which kingdom do bacteria belong?  
(b) Give any **two** benefits of bacteria to man
5. Name the phylum whose members possess notochord
6. The diagram below represents a bread mould:-

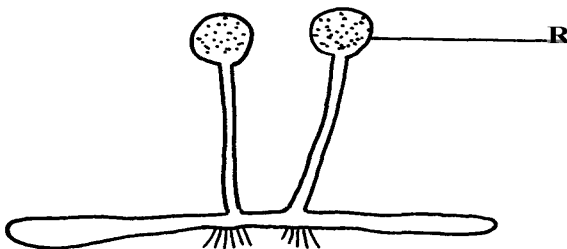

- (a) Identify the kingdom to which the organism belongs:-
7. Give a reason why no moulting occurs during the adult stages of insects
8. Name the branch of Biology that deals with the study of animals
9. State **four** ways in which some Fungi are beneficial to human
10. During a class practical form four students came across a plant whose flower floral parts were in multiples of fours and fives. To which sub-division and class does the plant belong?
11. A student caught an animal which had the following characteristics:-
  - Body divided into two parts
  - Simple eyes
  - Eight legs
  - The animal belongs to the class
12. The diagram below represents a bread mould.

- (a) (i) Name the Kingdom to which bread mould belongs.  
(ii) Give **two** distinguishing characteristics of the Kingdom named in (a)(i) above.  
(b) State the function of the part labelled R
13. (a) What is meant by the term taxonomy?  
(b) The scientific name of a rat is *Rattus norvegicus*  
(i) Write the name correctly  
(ii) Identify the genus and species names
14. List **three** features that distinguish arthropods from other organisms

## 2. The cell – structure & functions of organelles

1. Name the organelles that perform each of the following functions:  
a) Digestion and destruction of worn out organelles.  
b) Osmoregulation
2. Explain why the following processes are important during the preparation of temporary slides :-  
(a) Staining  
(b) Use of a sharp cutting blade
3. In a class experiment to establish the size of an onion cell, a learner observed the following on

the microscope field of view.

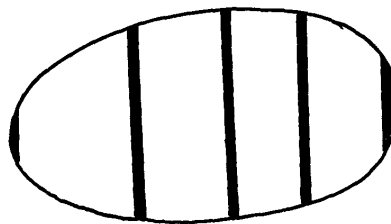

If the student counted 20 cells across the diameter of this field of view, calculate the size of one

cell in micrometers.

4. State the functions of the following cell organelles: (a) Nucleolus.  
(b) Plasma membrane
5. What is the of nucleus of a cell made up of?
6. (a) In a laboratory exercise a student observing a drop of pond water under a microscope saw  
and drew a spirogyra. If the magnification of the eye-piece was x5 and that of the objective

lens was x100, what was the magnification of the spirogyra?

(b) If the spirogyra has a length of 5cm at the above magnification, calculate the actual length

in micrometers

7. (a) Identify the organelle shown below:-

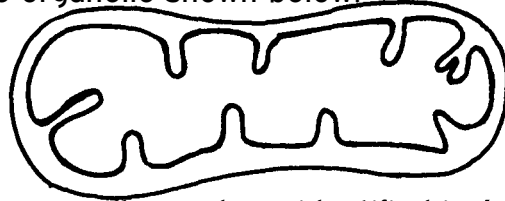

(b) How is the organelle you have identified in (a) above suited to its function

8. Identify the structures of the cells that perform the following functions:-

(a) Synthesize ribosomes

(c) Regulate exchange of substances in and out of the nucleus

9. (a) State the roles of enzyme catalase in living cells

(b) Which factor inactivates enzyme?

10. The figure below represents a certain cell organelle:-

**A**

(a) (i) Identify the cell organelle

(ii) What is the function of the part labelled **A**

(b) Name the organelles that perform each of the following functions;

(i) Osmoregulation in amoeba

(ii) Carries out digestion and destruction of worn out cell organelles

11. State **three** properties of the cell membrane

12. The diagram below represents a plant cell

(a) Name a carbohydrate which forms part of the structure labelled **S**

(b) State **two** functions of the part labelled **R**

(c) Name **two** structures present in the diagram but absent in the animal cell

13. What do you understand by the following terms

a) Anatomy

b) Biochemistry

14. State the function of the following parts of a cell

a) Ribosome

b) Chloroplasts

15. a) What is the formula for calculating linear magnification of a specimen when using a hand lens

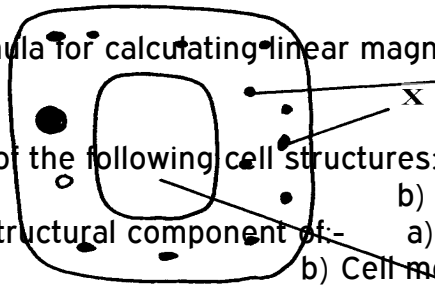

16. State the function of the following cell structures:- a) Ribosome ;

b) Centrioles ;

17. What is the main structural component of:- a) Cell wall

b) Cell membrane

18. State **two** characteristics of the kingdom monera which are prokaryotes

19. The diagram below represents a cell

(a) Name parts labelled X and Y

b) Suggest why the structures labelled X would be more on one side than the other

20. During a practical class, four students estimated the field of view to be 3.5mm. Using the low

power objective, they observed spirogyra cells across the same field of view and counted 8 cells.

Calculate the size of each cell and give your answer in micrometer

21. A student caught an animal which had the following characteristics:-

- Body divided into two parts
- Simple eyes
- Eight legs

a) To what class does the animal belong?

b) State **two** distinctive characteristics of members of the phylum from which the animals in this question (15) belongs

22. Distinguish between the following terms :-

- a) Magnification and resolution of a microscope
- b) Mounting and staining of a specimen

23. Name the organelle that performs **each** of the following functions in a cell.

- (a) Transport of packaged glycoproteins
- (b) Destruction of worn out cell organelles
- (c) Synthesis of proteins

24. Why are the following procedures done when preparing sections to be observed under a light microscope?

- (a) Making of thin sections
  - (b) Using a sharp blade to make the sections
  - (c) Staining
25. What are the functions of the following parts of a light microscope?
- (a) Eye piece lens
  - (b) Condenser
  - (c) Diaphragm
26. Given that the diameter of the field of view of a light microscope is 2000um. Calculate the size of a cell in mm if 10 cells occupy the diameter of the field of view
27. State the importance of the following processes in microscopy:
- (a) staining
  - (b) sectioning
28. A cell was found to have the following under a light microscope; cell membrane, irregular in shape, and small vacuoles. Identify the type of the cell above
29. State the functions of the following organelles;
- (a) Lysosomes
  - (b) Golgi apparatus
30. Name the class in phylum arthropoda which has the largest number of individuals
31. State the functions of each of the following parts in a microscope.
- (a) The eye piece lens
  - (b) The objective lens
32. The figure below represents an electron micrograph of an organelle that is found in many cells;

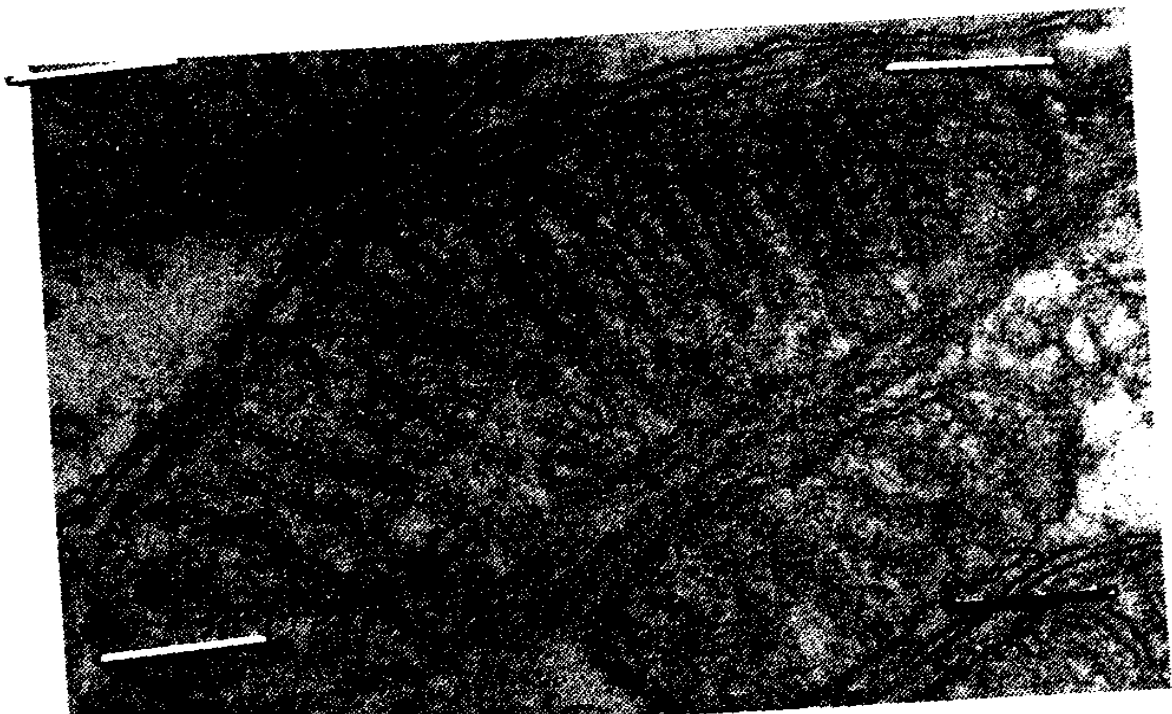

- (a) Identify the organelle
- (b) State the function of the organelle
- (c) What is the importance of infoldings in the inner membrane.
- (d) Give **two** examples of tissues where you would expect many such organelles in

animal body.

### 3. Cell Physiology – Osmosis, Diffusion and Active transport

- 1. Two equal strips **A** and **B** were from a potato whose cell was 30% of sugar. The strip **A** was placed in a solution of 10% sugar concentration while **B** was placed in 50% sugar concentration
  - a) What change was expected in strip **A** and **B**
  - b) Account for the change in strip **A**
- 2. An experiment was set-up as shown below and left for one hour

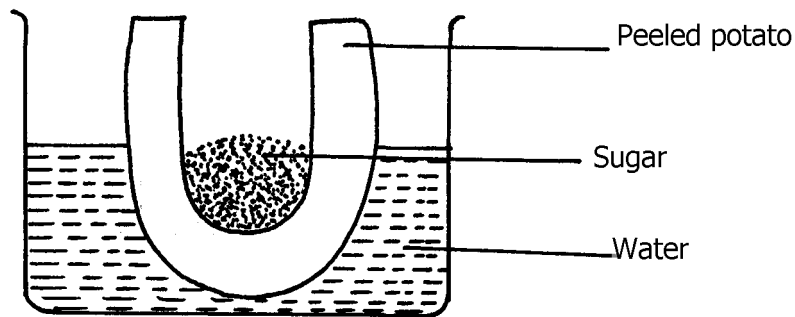

- (a) State the expected result at the end of one hour
- (b) Explain the observations made in this experiment
- 3. State what would happen in each of the following:-
  - (a) A plant cell placed in: - (i) Strong salt solution
  - (ii) Distilled water
- 4. State **three** physiological processes that are involved in movement of substances across the cell membrane
- 5. Potato cylinders were weighed and kept in distilled water overnight. They were then reweighed.

2.5 g 2.4g 2.7g

At the beginning of the Experiment.

3.0 g

3.1 g

3.2g

At the end of the experiment



- a) Calculate the average mass of a potato cylinders after reweighing. Show your working.  
 b) Explain why mass of the cylinders had increased.  
 6. The diagrams below show a red blood cell that was subjected to a certain treatment.

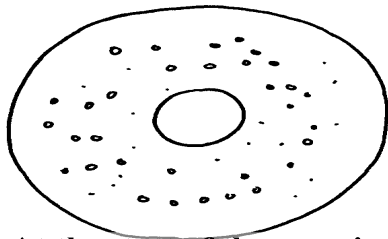

At the start of the experiment

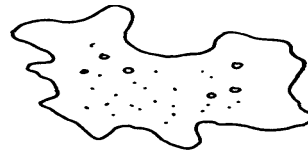

At the end of the experiment

- a) Account for the shape of the cell at the end of the experiment.  
 b) Draw a diagram to illustrate how a plant cell would appear if subjected to the same treatment

7. The diagram below shows the results obtained when red blood cells are placed in different

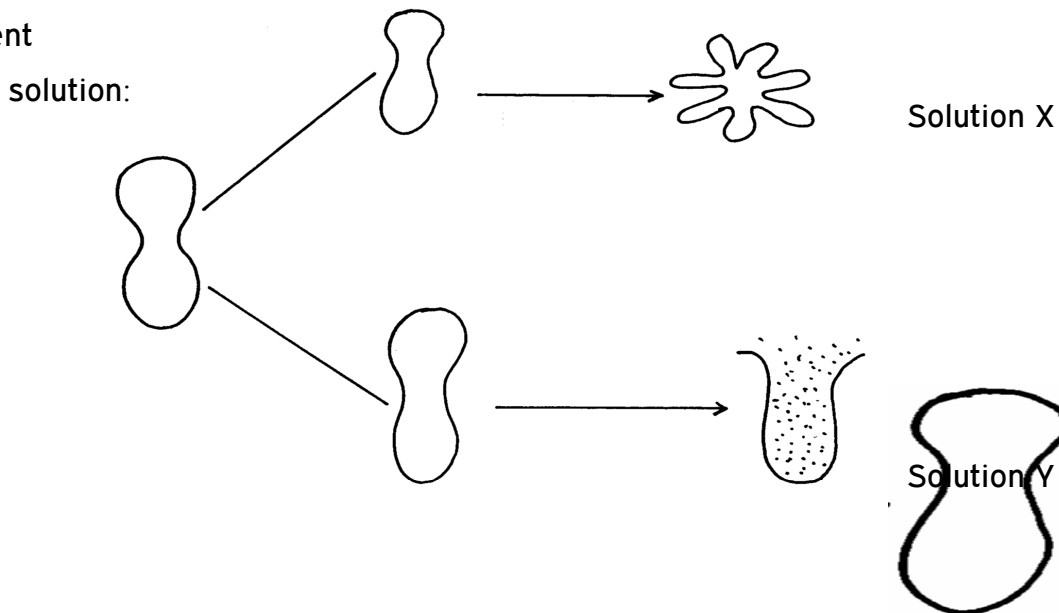

- (a) What name is given to the process that occurs when the cell is placed in solution Y?  
 (b) Describe the process that would occur in a plant cell when placed in a similar solution as that of solution X

8. The figure below shows the results obtained when red blood cells are put in different solutions:-

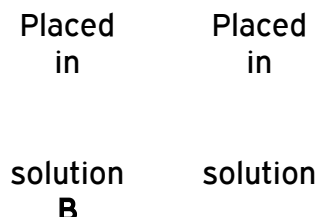

- (a) What is the name given to the process that occurs when the cell is put into solution B?  
 (b) Compare the results obtained when the cell is put in solution B to the results that would be obtained if a plant cell was put in the same solution

9. Briefly state **two** adaptation for each of the following cells to their functions

- (i) Spermatozoon
- (ii) Palisade mesophyll cell

10. The diagram below represents a cell at a certain stage in meiotic cell division

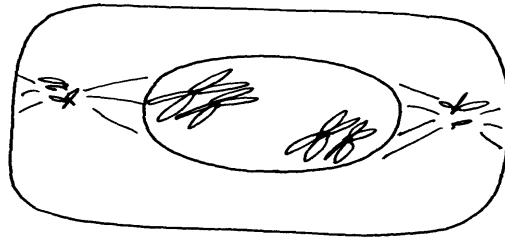

- a) Name the stage at which the cell drawn above represents
  - b) Give a distinguishing reason for your answer in 21(a) above
  - c) State any **two** differences between mitosis and meiosis
11. What are **two** differences between tropisms and tactic movement
12. An experiment was carried out to investigate the effect of different concentrations of sodium

chloride on human red blood cells. Equal amounts of blood were added to equal volumes of the

salt solution but of different concentrations. The results are shown in the table below:

Set -up	Sodium chloride concentration	Number of red blood cells	
		At start of experiment	At the end of the experiment
A	0.9%	Normal	No change in number
B	0.3%	Normal	Fewer in number

- (a) Account for the results in the set-up
- (b) If the experiment was repeated using 1.4% sodium chloride solution, state the expected

results with reference to:

- (i) the number of red blood cells
  - (ii) the appearance of red blood cells if viewed under the microscope
13. Name support tissues in plants characterized by the following
- (i) Cells being turgid
  - (ii) Cells being thickened by cellulose
  - (iii) Cells being thickened by lignin

14. The diagram below illustrates the behaviour of red blood cells when placed into two different

solutions X and Y.

- (a) Suggest the nature of solutions X and Y.
- (b) Name the process A and B.
- (c) What would happen to normal blood cell if it were placed in a solution isotonic.

15. Name **two** plant processes in which diffusion plays an important role

16. Two fresh potato cylinders of equal length were placed one in distilled water and the other in

concentrated sucrose solution:

(a) Account for the change in length of the cylinder in:

- (i) Distilled water
- (ii) Sucrose solution

(b) (i) What would be the result in terms of length if a boiled potato was used?

(ii) Explain your answer in (b)(i) Above

(c) State **two** uses of the physiological process being demonstrated in the

experiment

17. The two cells shown below are obtained from two different potato cylinders which were

immersed in two different solutions P and Q.

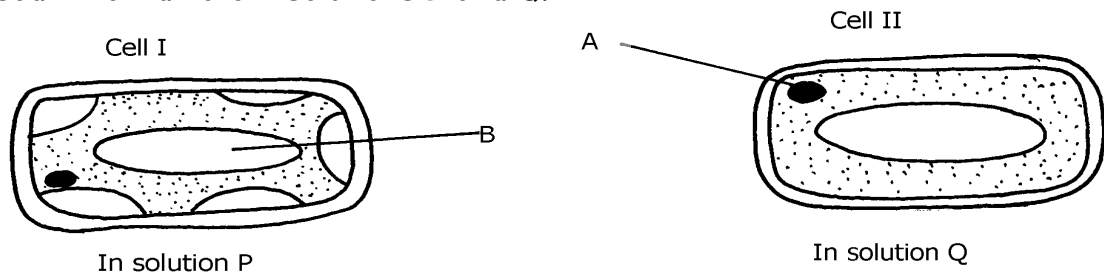

- a) i) Name the structure labelled A.
- ii) State the function of structure B.
- b) If eight of cell I were observed across the diameter of the field of view of 0.5 mm. Work out the actual diameters of each cell in micrometers.
- c) Suggest the identity of the solution Q.
- d) Account for the change in cell I above.
- e) State any **one** importance of the physiological process being demonstrated above in animals.

18. An experiment shown below was set-up to investigate a certain physiological process in plants:-

- (a) What process was being investigated?
- (b) Give the role of the oil layer in this experiment

- (c) (i) What observation did the students make after leaving the set-up in bright sunlight for two hours?  
(ii) Explain the observation in (c)(i) above
- (d) What effect will the following have on the observation made?:-  
(i) Fanning the shoot  
(ii) Removing all the leaves from the shoot  
(iii) Placing the set-up in the dark
- (e) Suggest a suitable control for this experiment
19. Study the following food web and answer questions that follow:

- (a) (i) Name the organisms that occupy the second trophic level  
(ii) What is the other name for the second trophic level
- (b) Write down **two** food chains from the food web that:  
(i) End with hawks as tertiary consumer  
(ii) End with hawks as quaternary consumer
- (c) Giving reasons state;  
(i) the organism with largest biomass  
(ii) the organism with least biomass

## 4. Nutrition in (a) plants (b) animals

1. The chemical equation below represents a physiological process that takes place in living organisms:



- (a) Name the process R  
(b) Name the substance Q

2. The diagram below shows cells in plants:-

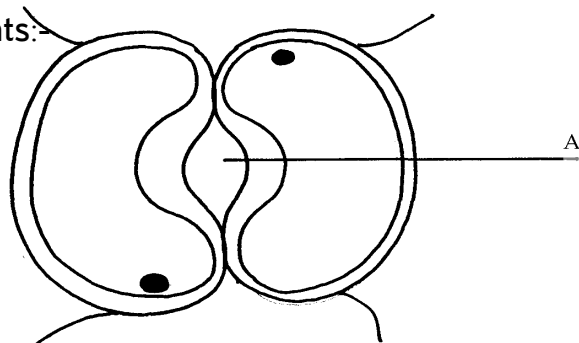

- (a) Identify the cells shown above
  - (b) Explain how the cells are adapted to their function
  - (c) Explain how accumulation of carbon (IV) Oxide in the cells above would lead to the closure of structure **A**
3. (a) A leaf of a potted plant kept in darkness for 48hours was smeared with Vaseline jelly then exposed to sunlight for 8hours. Explain why the test for starch in the leaf was negative
- (b) Name **two** other processes that were interfered with in the plant
4. List **two** functional differences between plants and animals.
5. Explain how the guard cells are adapted to perform their function.
6. The diagram below shows chemical reactions **A** and **B** which are controlled by enzymes **x** and **y** respectively.

- (a) Name: (i) Reaction **A**.
  - (ii) Enzyme **y**
7. What are the **two** functions of bile salts during the process of digestion?
8. State **three** adaptations of aquatic plants to photosynthesis
9. A biological washing detergent contains enzymes which remove stains like mucus and oils from clothes which are soaked in water with the detergent:-
- (a) Name **two** groups of enzymes that are present in detergent
  - (b) Explain why stains would be removed faster with the detergent in water at 35°C rather than at 15°C
10. Name the diseases caused by deficiency of : (a) Iodine  
(b) Vitamin C
11. Name **two** enzymes and **one** metal ion that are needed in the blood clotting process
12. The diagram below shows how food boles move along the human oesophogus and the Intestine

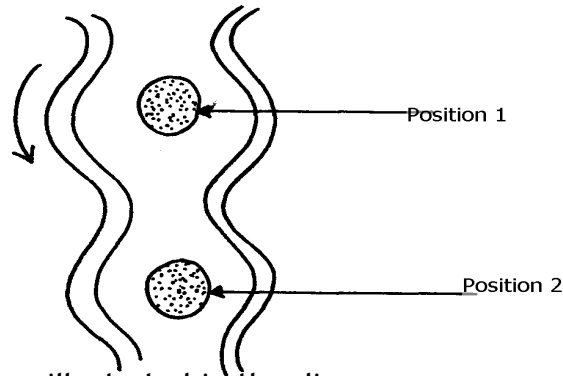

(a) Identify the process illustrated in the diagram

(b) Briefly **state** how the movement of food boles from position 1 to position 2 is achieved

(c) Name **one** component of a persons diet that assists in the movement of food described in

(b) above

13. State **two** adaptations of herbivores which enable them to digest cellulose

14. State **two** factors that affect the rate of osmosis

15. A certain organ **K** was surgically removed from a rat, later drastic increase in glucose level in the

blood was reported but when substance **Q** was injected into the animal the whole process was

reversed.

Identify: (i) Organ **K**

(ii) Substance **Q**

16. a) Name the component of a persons diet that is essential for peristalsis

b) Give **two** groups of food which are reabsorbed along the mammalian digestive system

without undergoing digestion

17. State **three** roles of light in photosynthesis

18. State **two** ways in which the guard cells differ their adjacent epidermal cells

19. One of the components of bile is a chemical left over from destruction of red blood cells

i) Identify the chemical substance

ii) What is the role of bile in digestion

20. (a) What is peristalsis?

(b) Explain how the process above is brought about.

21. The following reaction may occur in a forward and backward direction.



(a) Name the organelle where the reaction occurs in:

(i) Forward direction

(ii) Backward direction

(b) Give **one difference** and **one similarity** for the two organelles named in (a) above

22. A solution of sugar cane was boiled with hydrochloric acid and sodium hydrogen carbonate was added to the solution, which was then boiled with benedicts solution. An orange precipitate was formed.

(a) Why was the solution boiled with hydrochloric acid and then sodium hydrogen carbonate

added in it

(b) To which class of carbohydrates does sugar cane belong?

(c) State the form in which carbohydrates are:

(i) Transported in animals

(ii) Transported in plants

23. The diagram below is of a certain type of neurons...

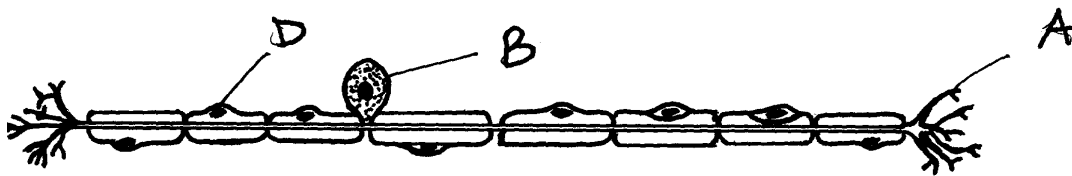

(a) Identify the type of neuron

(b) Give a reason for your answer in (a) above

(c) Give the functions of the parts labeled A, B, and D

24. a) The mitochondria organelle has cristae structure on the inner membrane. State the function of the cristae

b) The diagram below represents a cell organelle

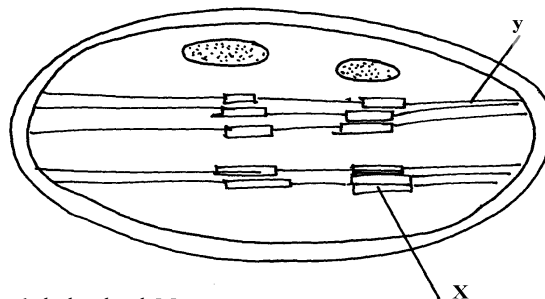

i) Name the part labeled Y

ii) State the function of the part labeled X

25. a) State the role of emulsification in the digestion of fats in the alimentary canal

b) What is the function of hydrochloric acid in the alimentary canal

26. Briefly explain the effect of poisoning the roots hair on the uptake of nitrate by plants

27. Briefly explain the symbiotic relationship in the root nodule of a leguminous plant

28. Explain how saliva is important in digestion
29. What is the fate of excess glucose in plants?
30. State **two** ways in which guard cells differ from other epidermal cells
31. Briefly explain the fate of the following products from the light stage of the process of Photosynthesis:
- (a) Oxygen
  - (b) Hydrogen
  - (c) ATP

32. In an experiment to investigate on aspect of digestion, two test tubes A and B were set-up as

shown in the diagram below;

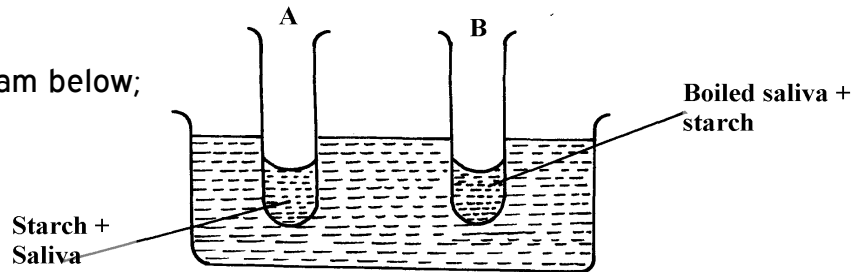

The test tubes were left in the bath for 30 minutes. The content of each test tube was then tested for

starch using iodine solution:-

- (a) What was the aim of the experiment?
  - (b) What results were expected in test-tube **A** and **B**
  - (c) Account of the results you have given in (b) above in test tube **A** and **B**
33. Below is a process that takes place along the mammalian digestive system:

- (a) Name the processes represented by **A** and **B**
- (b) Name part of the alimentary canal where the process **B** takes place

34. The diagram below represents a cell organelle

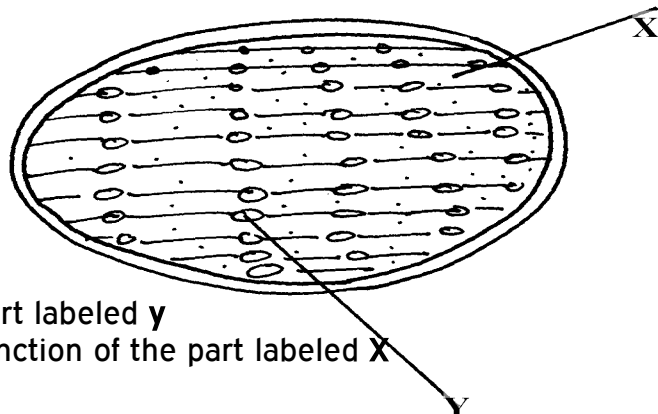

- (i) Name the part labeled **y**
  - (ii) State the function of the part labeled **X**
- (ii) State the function of the vitamin named in (i) above



36. (a) Name the disease caused by **schistosoma** parasites in man.  
(b) How is **schistosome** adapted to its parasitic mode of life?
37. The table below shows **three** enzymes **A**, **B** and **C** and their respective optimum pH.

Enzyme	Optimum pH
A	6.8
B	2.0
C	8.0

- (a) (i) Name the most likely region of the alimentary canal of a mammal where enzyme **B** would be found.  
(ii) Give a reason for your answer in (a) (i) above
38. In an experiment to investigate an aspect of digestion, two tubes A and B were set up as shown in the diagram below.

The test tubes were left in the water bath for 30 minutes. The content of each tube was then tested

for starch using iodine solution.

- (a) What was the aim of the experiment?  
(b) Explain the expected in the tube.
39. (a) Name the specific part of the chloroplast where the following processes occur.  
(i) Carbon IV oxide fixation  
(ii) Photolysis  
(b) State **one** way in which the dark reactions of photosynthesis depends on light reaction.
40. The concentration of carbon IV oxide in a tropical forest was measured during the course of 24

hour period from mid-night. The graph below shows the results obtained.

Account for the results obtained at: (i) Midnight.  
(ii) At 12.00 noon.

41. State **three** ways by which the rate of enzyme controlled reactions can be increased.
42. Study the dental formula given below:

$$\begin{array}{cccc} \text{I } \underline{0}; & \text{C } \underline{0}; & \text{PM } \underline{3}; & \text{M } \underline{2} \\ \underline{4} & \underline{0} & \underline{3} & \underline{3} \end{array}$$

- (a) Identify with reasons the mode of feeding of the animals whose dental formula is given above
- (b) Calculate the total number of teeth in the mouth of the above animal
43. Explain why small mammals such as moles feed more frequently than larger ones such as elephants
44. State **three** ways by which plants compensate for lack of the ability to move from one place to another
45. Study the diagram below and answer the questions that follow

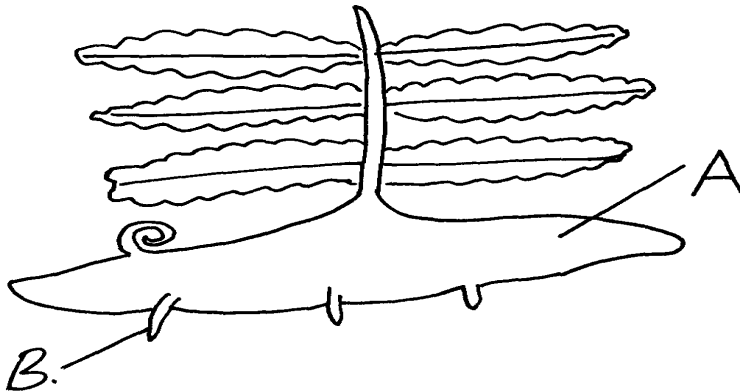

- (a) Label the parts **A** and **B**
- (b) State **one** observable difference between the structure above and the liverwort
46. What is glycolysis?
47. (a) State **two** difference between monosaccharide and polysaccharides
- (b) Name the bond found in proteins
48. Name **two** products of light reaction used in the dark reaction
49. State **two** functions of the large intestine in humans.
50. The diagram below shows a leaf of a growing plant partly covered with aluminium foil. The plant was placed in the sun from morning to midday and then tested for starch.

- (a) What was the aim of the experiment?
- (b) State the observation made when the leaf was tested for starch
51. The figure shows the effect of temperature on an enzyme catalyzed reaction.

(a) Explain what happens between **A** and **B**

(b) What is **X**?

52. Name **two** mineral elements that are necessary in the synthesis of chlorophyll.

53. The figure below is a diagram of the anterior portion of the tapeworm. **Taenia solium**.

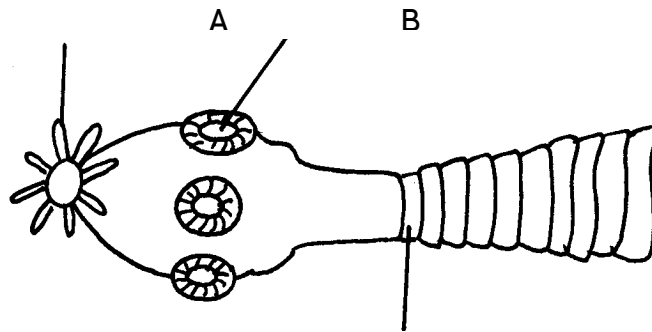

(a) Name the parts labeled **A**, **B**, and **C**

(b) What is the intermediate host of *Taenia Solium*?

54. The diagram below represents a longitudinal section through the ileum wall

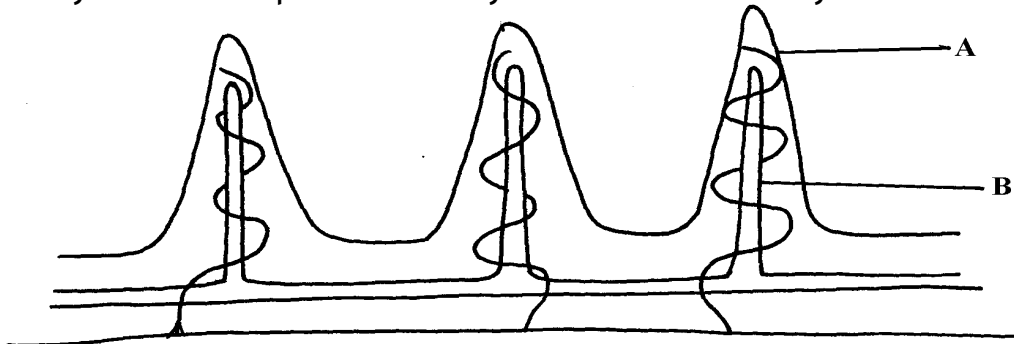

a) Identify the structure labeled **A** and **B**

b) State **one** function of **A** and **B**

c) State **two** functions of the ileum

d) Explain the role of the liver in digestion

e) State the endocrine role of the pancreas in a mammal

55. The chart below shows the relationship between concentration of CO<sub>2</sub> around the plant and the rate of photosynthesis

- (a) Account for the rate of photosynthesis between D-E
- (b) Account for the rate of photosynthesis between F-G
- (c) Briefly describe the reactions during the light stage of photosynthesis

56. The diagram below shows the effect of varying light intensity on the exchange of carbon IV oxide between the leaves of a green plant and the atmosphere.

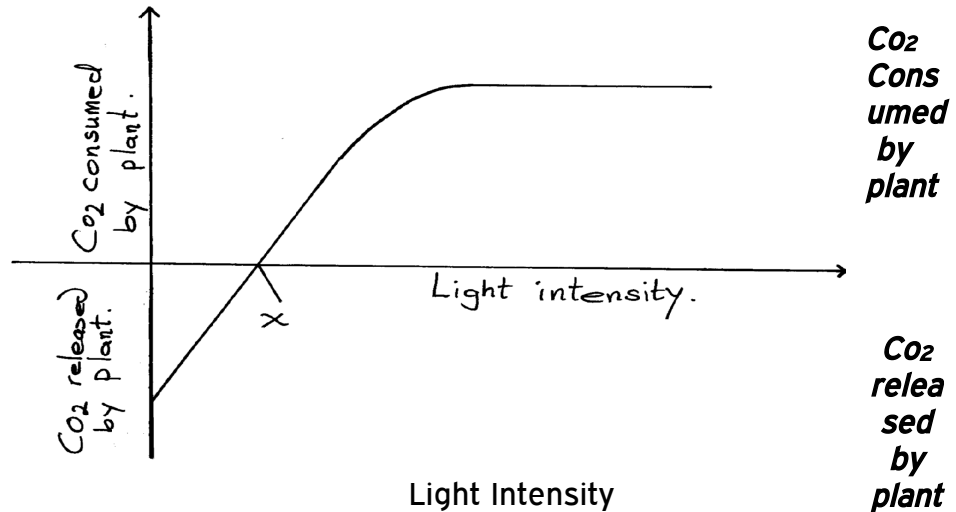

- a) What is the name given to the point marked x?
- b) i) With reference to carbon IV oxide exchange state what happens at point x.  
ii) Explain how the effect observed at point x occurs.
- c) Explain why there is a net uptake of carbon IV oxide at light intensity above x.
- d) What would happen to the plant if light intensity falling on it were maintained at x throughout?
- e) What can you say about the exchange of oxygen between the plant and the surrounding air at intensities below x?

57. The following diagram of a leaf shows what happens in a pant leaf during photosynthesis:-

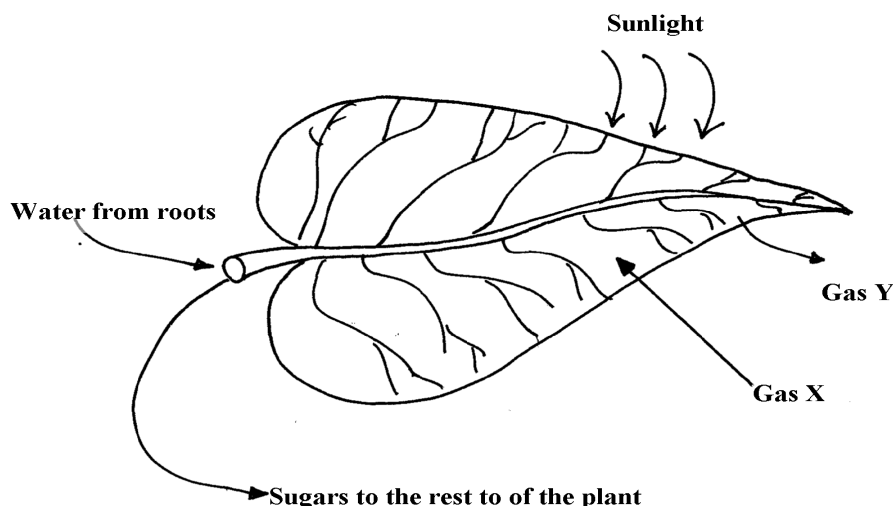

- (a) Give **two** ways in which leaves are adapted to absorb light
- (b) Name the gases labelled **X** and **Y**
- (c) Name the tissue that transports water into the leaf and sugars out of the leaf
- (d) Explain why it's an advantage for the plant to store carbohydrates as starch rather than as sugars

58. (a) What is meant by digestion?

(b) Describe how mammalian small intestine is adapted to its function

59. Form one students from Inungo school arranged their apparatus as shown below, to investigate a

certain phenomenon. The set up was placed in light.

(a) State the likely aim of the set up

(b) State the role of the syringe in the set-up above

(c) (i) Name gas **X**

(ii) Write an equation to show how gas **X** was formed in the set-up

(d) State **three** factors that increase the rate of enzyme activity

(e) Give a reason why the test tube is immersed in a beaker of water

60. A student was culturing *E. coli* (a bacterium) in a Petri-dish. He placed the Petri-dish in an

incubator at 30°C. He removed it from the incubator the following day and found that five

colonies of bacteria had grown. He decided to return it into the incubator to give it more time.

When he removed it fourteen days later, he could not observe any colony.

a) Why was there no colony on the fourteenth day?

b) Explain how bacteria cause spoilage of stored food in warm moist conditions.

c) Name other organisms which also cause food spoilage.

d) State their economic importance to nature.

61. The table below shows the results of an experiment carried out to determine the rate of photosynthesis at different light intensities and varying Carbon (IV) oxide concentrations. The rate was determined by counting the number of bubbles per minute. The temperature was kept constant

Light intensity in lux	% carbon(IV)oxide concentration						
	0.0%	0.3%	0.6 %	0.9 %	1.2%	1.5%	1.8%
1500	0	16	30	38	40	40	40
6000	0	52	80	96	100	98	100
10000	0	80	100	115	120	122	120

- a) On a graph paper provided, draw a graph for each of the light intensities. All the three graphs should be plotted on the same axis (rate of photosynthesis on vertical axis and carbon (IV) oxide concentration on horizontal axis)
- b) What is the effect of an increase in carbon (IV) oxide concentrations and light intensities
- c) Briefly explain how aquatic green plants meet light intensities and carbon (IV) oxide requirement
- d) Using the data provided in the table state **two** factors required by the green plants for food production

62. Explain how the mammalian intestines are adapted to perform their function.

63. A healthy plant was kept in the dark for 24hours following which two of its leaves were enclosed

in glass flasks as shown below. The set up was the exposed to sunlight for a number of hours.

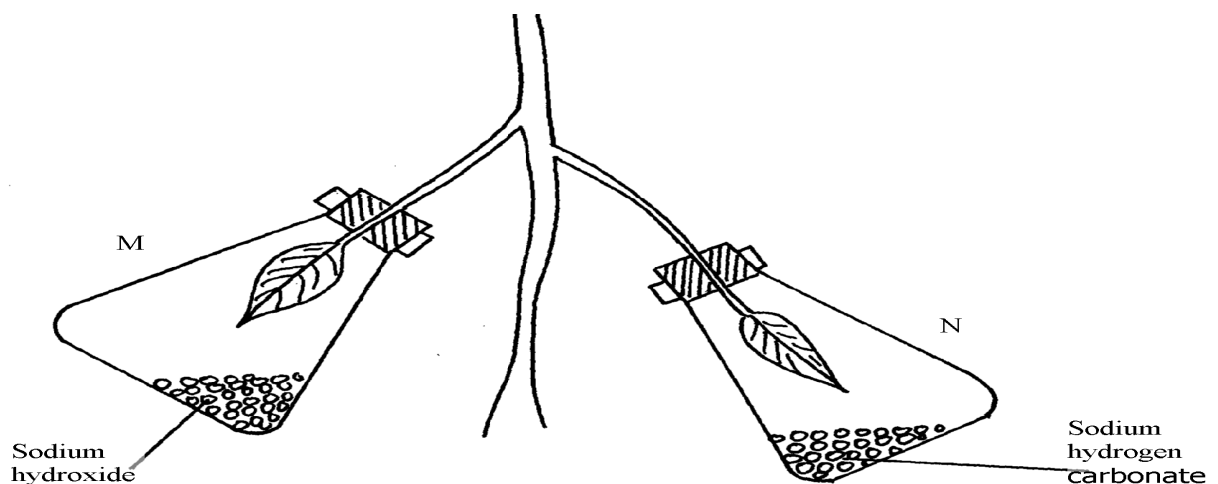

- (a) Why was it necessary to keep the plant in the dark for 24 hours?  
 (b) Give the function of each of the following in the experiment  
 (i) Sodium hydroxide  
 (ii) Sodium hydrogen carbonate  
 (c) Explain the expected results in leaf.  
 (i) **M** when tested for starch  
 (ii) **N** when tested for starch?  
 (d) Suggest a suitable control for this experiment
64. The diagram below shows an experiment that was carried out to measure how fast a were  
 plant such as Elodea photosynthesizes

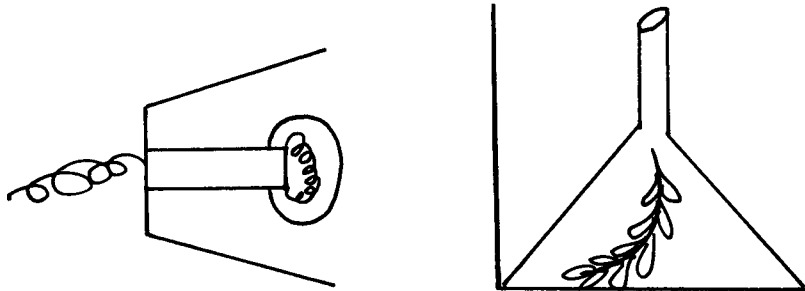

The shoot was exposed to different light intensities and the rate of photosynthesis estimated by counting the number of bubbles of gas leaving the shoot in a given time. the results are given below;

<b>Number of bubbles per minute</b>	7	14	20	24	26	27	27	27
<b>Light intensity (Arbitrary units)</b>	1	2	3	4	5	6	7	8

- a) Plot these data on a piece of graph paper provided  
 b) At what light intensity did the shoot produce ;  
 i) 18 bubbles per minute  
 ii) 25 bubbles per minute  
 c) Give **two** better ways of measuring the rate of photosynthesis than counting bubbles  
 d) What is the role of light intensity in photosynthesis  
 e) Account for the expected results of doing this experience at the following temperature;  
 i) 4°C  
 ii) 34°C  
 iii) 60°C  
 f) Other than light intensity and temperature, name other factors that affect the rate of photosynthesis
65. In an experiment, a leaf from a plant which had been kept in the dark overnight was boiled in water for a minute. It was then boiled in alcohol and washed in warm water. Iodine solution was then added onto the leaf:  
 (a) Why was the leaf boiled in;- (i) Water  
 (ii) alcohol  
 (b) (i) What observation was made on the leaf after adding iodine solution  
 (ii) Give a reason for your answer in (b) above  
 (c) What was the aim of the experiment

- (d) Why was it necessary to wash the leaf in warm water
- (e) What is a variegated leaf?
- (f) Write a word equation for the process of photosynthesis

### 5. Transport in (a) plants (b) animals

1. Explain why a fresh wound on the skin bleeds more on a hot sunny day than on a cold chilly day
2. State **three** adaptations of red blood cells to their functions.
3. How are sieve tube elements adapted to their function
4. Name the **polysaccharides** found in the following structures:-  
(a) **Exoskeleton**  
(b) **Xylem vessels**
5. State **three** factors that maintain transpiration stream
6. (a) List **three** forces that facilitate the transport of water and mineral salts up the stem.  
(b) Name the tissue that is removed when the bark of a dicotyledonous plant is ringed.
7. Study the dental formula of an organism below..  
 $I^{3/3}, C^{1/1}, Pm^{3/2}, M^{1/1} = x$ 
  - (a) (i) What is the total number of teeth this organism possess?
  - (ii) What is the mode of feeding of the organism?
  - (b) State **two** functions of mucus produced along the alimentary canal.
8. The diagram below shows a bone obtained from a mammal.

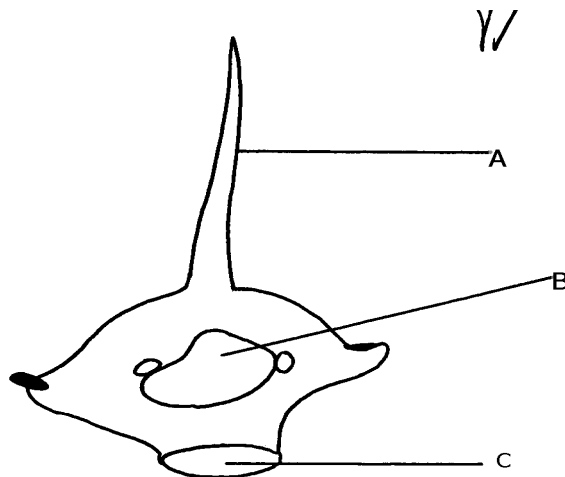

- (a) Name the part of the skeleton from which the bone has been taken.
  - (b) Label the parts **B** and **C**.
  - (c) State the functions of part **A**.
9. What is the destination of materials translocated in plants.
  10. A person whose blood group is **AB** requires a blood transfusion, name the blood groups of the donors.
  11. Explain why capillaries are:
    - (i) Thin walled
    - (ii) Branched



12. An experiment was set-up as shown below to investigate a certain plant process:

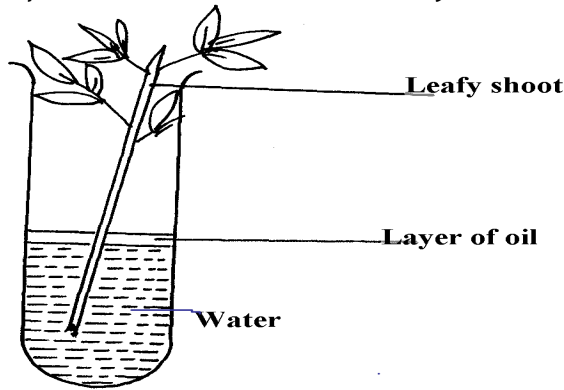

- (a) What process was being investigated above?  
 (b) What observation was made if;  
 (i) The experiment was left in strong wind for one hour?  
 (ii) All the leaves were removed from the plant?
13. How is aerenchyma tissue adapted to its function
14. (a) State **three** structural differences between arteries and veins in mammals  
 (b) Name a disease that causes thickening and hardening of arteries
15. Identify **two** forces that help in upward movement of water in plants
16. State **three** ways in which red blood cells are adapted to their functions
17. (a) Distinguish between tissue fluid and lymph  
 (b) Explain why deficiency of vitamin **K** leads to excessive bleeding even from small cuts
18. Name the type of circulatory system found in the phylum Arthropoda
19. Name the blood vessel that nourishes the heart
20. a) In which form is oxygen transported in the blood.  
 b) Why do plants not take in oxygen during the day although they need it for respiration
21. Name a disease of the blood characterized by excessive production of white blood cells
22. Laboratory analysis of a patient's urine revealed the following concentration of various substances:

Blood proteins	0.00%
Water	50%
Glucose	48%
Salts	0.8%
Urea	1.2%

- a) From the analysis above, which disease is the patient suffering from  
 b) Name **two** symptoms of the disease in **3(a)** above
23. The diagrams below show two conducting elements of the xylem tissue

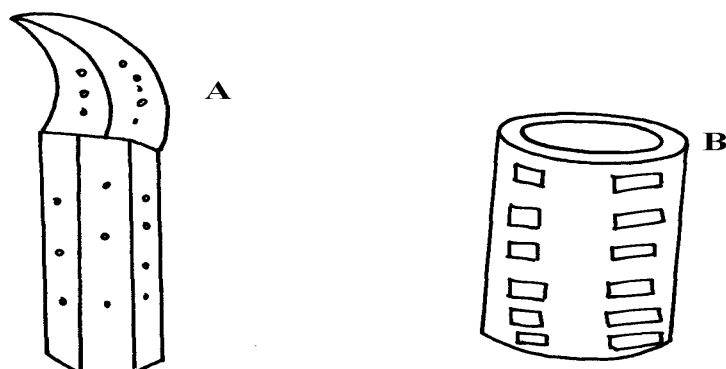

- a) Identify each of them A and B  
b) What makes the cellulose side walls of both A and B able to prevent collapsing?
24. Explain why the rate of transpiration is reduced when humidity is high
25. (a) State **two** functions of the xylem vessels,  
(b) List **two** structural adaptations that make xylem vessels suitable to their function
26. (a) What is peristalsis?  
(b) Explain how the process above is brought about.
27. The diagram below shows a part of a circulatory system. The arrows indicate the direction of the  
flow of blood;

- (a) Identify the blood vessels labeled **A** and **B**  
(b) Explain why it is important to transport food substances to organ **C** before being released  
for circulation to the rest of the body
28. Name **four** methods plants employ to remove excretory waste products
29. a) State the form in which oxygen is transported in the mammalian blood  
b) Why is it dangerous to sleep in an enclosed room with a burning jiko  
c) Why do plants not take in oxygen during the day although they need it for respiration
30. Name a disease of blood characterized by excessive – production of white blood cells
31. The table below is a representation of a chromosomal mutation
- |                        |   |   |   |   |   |   |
|------------------------|---|---|---|---|---|---|
| <b>Before mutation</b> | L | M | N | O | P | Q |
| <b>After mutation</b>  | L | O | N | M | P | Q |
- (a) Name the type of chromosomal mutation represented above  
(b) Name **one** mutagenic agent
32. The diagram shows a section through a plant organ.

- (a) (i) Name the class of the plant from which the section was obtained belong.  
(ii) Give a reason for your answer in (a)(i) above  
(b) How is the part labelled **C** adapted to its functions?
33. State **two** roles of transpiration to a plant
34. Uptake of water by plants is not affected by metabolic poisons. Explain.
35. The diagram below represents a plant tissue.
- (a) Identify each of them.  
(b) What property makes **B** to be more efficient in function?  
(c) What makes the walls of both **A** and **B** impermeable to water and solutes?
36. A woman gave birth to a child of blood group B<sup>+</sup> (B positive). Name the two antigens that determined her child's blood group.
37. A transfusion of Rh<sup>+</sup> blood was given to a patient with Rh<sup>-</sup> blood. After one week a similar transfusion was given to the same patient. What was likely to be the effect of the second transfusion?
38. The diagrams below show stages in the process of feeding shown by amoeba.
- (a) Name the part labeled **A**.  
(b) Name the process illustrated in the diagram above.  
(d) Name the type of cell in human beings that exhibit this process.
39. (a) Why are xylem vessels more efficient in the transport of water than tracheids?  
(b) What is the significance of xylem vessels being dead?
40. Distinguish between guttation and transpiration
41. Other than transport, state one other function of xylem tissue in plants
42. State **two** functions of aerenchyma tissue in plants
43. (a) What is sickle-cell anaemia?  
(b) Identify the part of the heart that initiates the heart beat
44. (a) Give a reason why the left ventricle muscles are thicker than the right ventricles muscles

- (b) State the forms in which carbon (IV) oxide is transported in the blood
45. Explain how the following adaptation reduce transpiration in xerophytes
- (a) Sunken stomata
  - (b) Thick waxy cuticle
46. Name the:
- (a) Material that strengthens xylem tissue
  - (b) Tissue that is removed when the bark of a dicotyledonous plant is ringed
47. The diagram below shows the traverse section of a young stem.

- (a) What are the functions of the structures labeled **A**, **B** and **C**
  - (b) What type of cells are found in the parts labeled **D**
  - (c) Name the tissue labeled **E**
48. Name the components of blood that do not enter the renal tubule in mammals
49. Outline the route taken by a molecule of glucose from the ileum up to the kidney.
50. The flow chart below shows a blood transfusion pathway

- (a) What **three** conclusions can you draw from the flow chart?
  - (b) State **two** precautions that must be observed during blood transfusion
  - (c) Explain how blood clot is formed once a blood vessels is injured
51. The figure below represents a diagram of a photometer;

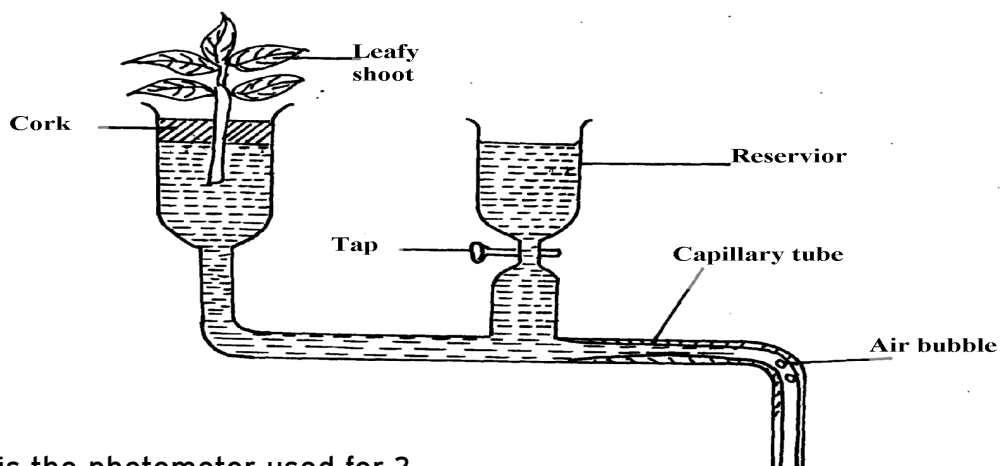

- (a) What is the photometer used for ?
- (b) State the precautions which should be taken when setting up a photometer

- (c) Explain what you will expect if set up was placed under the following environmental conditions;
- Dark room
  - Leafy shoot enclosed in polythene bag
  - In a current of air created by a fan

52. The amount of blood flow through various parts of the body of a mammal was measured in

$\text{cm}^3$  per minute at rest and during different physical activities. Results are shown below.

	Blood flow in $\text{cm}^3/\text{min}$		
	At rest	During light Exercise	During strenuous Exercise
Heart muscles	200	300	1050
Gut	1300	1000	400
Skeletal muscles	1100	5050	23000
Kidneys	900	650	250
Skin	400	1300	600

- Calculate the percentage change in blood flow through the skeletal muscles and gut when the mammal was exposed to strenuous exercise.
    - Skeletal muscles
    - Gut
  - Account for the differences in amount of blood flow through the gut and skeletal muscles;
    - At rest
    - During strenuous exercise
  - Account for the result obtained for the skin during light exercise
  - Name **two** substances which are removed from the body by the kidney
53. The diagram below represents a transverse section of a young stem.

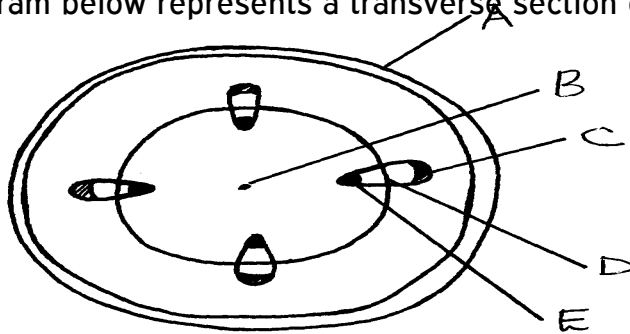

- Name the parts labeled **A**, **B** and **D**
  - State the functions of the parts labeled **C** and **E**
  - List **three** differences between the section above and the one that would be obtained from the root of the same plant
54. Describe the functions of the various components of the mammalian blood

## 6. Gaseous exchange in (a) plants (b) animals

- Name the site of gaseous exchange during breathing in mammals.
  - State **three** characteristics of the site named in (a) above.

2. Why would carboxyhaemoglobin lead to death?
3. State **two** causes of coronary thrombosis
4. What adaptation do red blood cells have for transportation of carbon (IV) oxide?
5. (a) What is Respiration Quotient (RQ)?  
(b) (i) Calculate the RQ of the food substance shown by the equation below.  
$$2C_{51}H_{98}O_6 + 145 O_2 \rightarrow 102CO_2 + 98H_2O + \text{Energy}$$
  
(ii) Name the food substance being oxidized in b (i) above.
6. Outline **three** ways in which the gills of Tilapia fish are modified to perform their function.
7. Identify the surfaces of gaseous exchange in the following:-
  - (i) Paramecium;
  - (ii) Roots;
  - (iii) Frog;
8. (a) Name **two** gaseous exchange  
(b) Explain how oxygen gets into the haemolymph of an insect
10. (a) Outline **two** physiological changes that occur in the body to lower the level of Carbon (IV) Oxide after vigorous physical exercise  
(b) Name the site of respiration in a cell
11. What is the importance of counter current flow in the exchange of gases in a fish
12. State **four** ways in which red blood cells (**RBC**) are adapted to their function
13. (a) (i) Where in a cell does glycolysis take place?  
(ii) Name the product of the above process  
(b) Briefly explain Krebs's cycle in a plant cell during anaerobic respiration
14. Describe the changes that occur to the rib cage and the diaphragm during inspiration
15. a) What is translocation  
b) Name **two** forces that maintain transpiration stream
16. Most carbon (IV) oxide is transported from tissues to the lungs within the red blood cells and  
not in the blood plasma. Give **two** advantages of this mode of transport
17. Give a reason why halophytes have pneumatophores
18. Give **two** characteristics of respiratory surfaces in animals
19. Give a reason for each of the following on mammalian Red blood cells
  - (a) Absence of the nucleus
  - (b) Biconcave shape
20. State **two** ways in which bodies of people living in high altitude areas respond to low oxygen concentration.
21. Explain what would happen to a mammalian Red blood cell 30 minutes after being placed in distilled water.
22. (a) State **two** ways in which the surface area of the fish filaments is increased for

efficient gaseous exchange.

(b) What is the importance of counter flow system in the filaments of a fish.

23. The apparatus below illustrates breathing in mammal.

Describe what happens if the rubber plug is pulled in the direction shown by the arrow.

24. Describe the path taken by oxygen gas from atmosphere to the tissues of an insect.

25. Why should respiratory surfaces be: (i) Moist  
(ii) Thin

26. The set up below represents an experiment to investigate the process of photosynthesis.

The set up placed in sunlight for six hours.

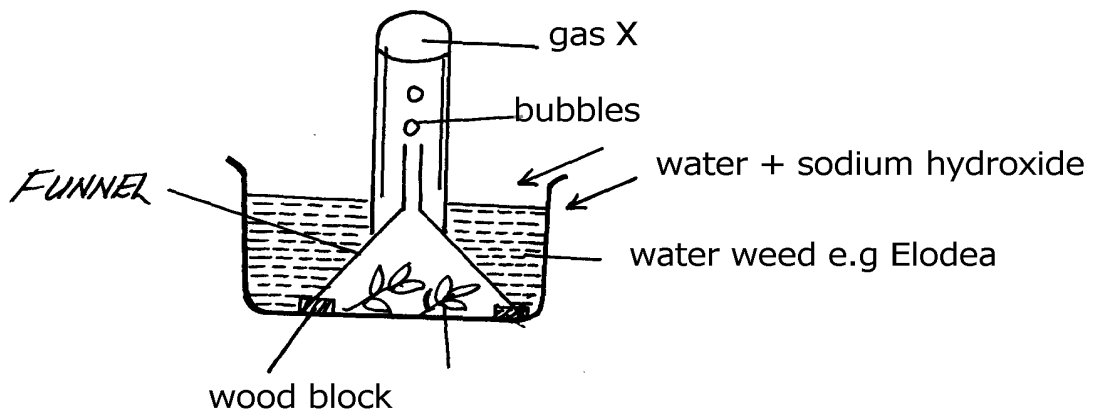

(a) Why was sodium hydrogen carbonate added to water in this experiment?

(b) Explain why the number of bubbles reduced by evening

(c) Explain why the water was used in this experiment

(d) Explain why the water was used in this experiment

27. (a) State **two** adaptations of red blood cell to its functions

(b) Name **two** ways in which carbon (IV) Oxide is transported in mammalian blood

28. The diagram below represents an organ from a bony fish. Study the diagram and

answer the

questions that follow:

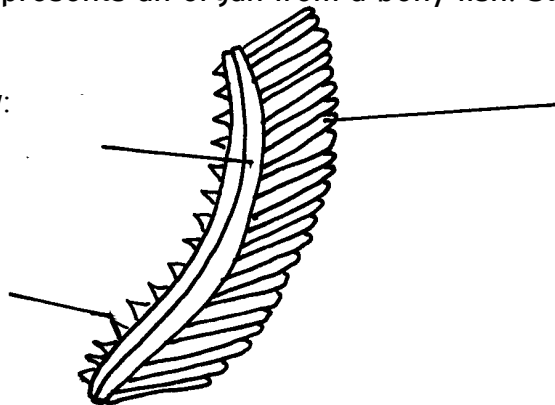

(a) State the functions of each of the following:

(b) How is the structure labeled C adapted to its function?

29. State how the tracheal system in insects is adapted for gaseous exchange.





(b) Using photosynthetic theory explain the mechanism of opening of stomata.  
 37. In an experiment to investigate a certain processes in a given plant species, the rate of carbon (IV)

oxide consumed and released were measured over a period of time of the day. The results of the

investigation are shown in the table below:

Time of the day (hours)	6	8	10	12	14	16	18	20	22	24
Carbon (IV) oxide consumed in mm <sup>3</sup> /min	10	43	69	91	91	50	18	0	0	0
Carbon (IV) oxide released in mm <sup>3</sup> /min	38	22	10	3	3	6	31	48	48	48

b) Name the biochemical processes represented by;

- (i) Carbon (IV) oxide consumption
- (ii) carbon (IV)oxide release

(c) Account for the shape of the curve for carbon (IV) oxide consumption between;

- (i) 6-16 hours
- (ii) 20-24 hours

(d) Account for carbon (IV) oxide released between 12-16 hours

(e) (i) What is compensation point?

(ii) From the graph state the time of the day when the plant attains compensation point

(f) Explain how high temperature above optimum affects the rate of carbon (IV) oxide consumption in the plant.

## 7. Respiration

1. (a) Distinguish between gaseous exchange and respiration

(b) Name the products of anaerobic respiration in plants

2. (a) State **two** phases of aerobic respiration

(b) With a reason, state the phase that yields more energy

3. A process that occurs implants is represented by the equation below:-

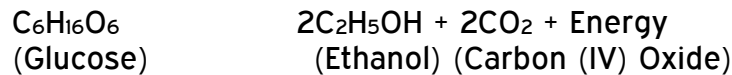

(a) Name the process

(b) State the economic importance of the process named in (a) above

4. Give a reason why it is difficult to calculate respiratory quotient (RQ) in plants

5. a) Explain what is meant by the term oxygen debt in human beings

b) What are the end products of anaerobic respiration in animals

6. The apparatus below was set up by a student to find out the changes in gases during germination

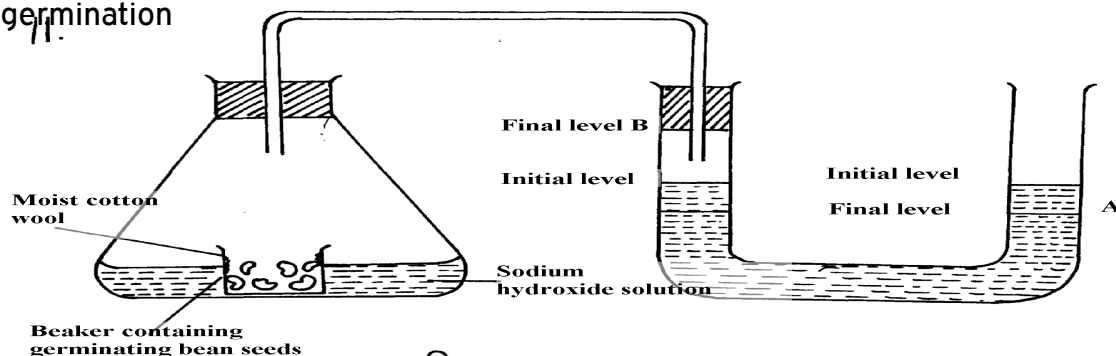

- a) After 48 hours the level of water in the U-tube at **A** and **B** was as shown. Explain the observation
- b) Calculate the respiration quotient (**RQ**) from the equation below:-  
$$2C_{51}H_{98}O_6 + 145O_2 \rightarrow 102CO_2 + 98H_2O + \text{Energy}$$
- c) Identify the substrate being respired in the above equation
7. One molecule of lipid gives more energy than one molecule of glucose when respired aerobically  
but it is NOT always used as a respiratory substrate
- a) Give **two** reasons for this
- b) Name **two** disaccharides which are reducing sugar
8. (a) (i) Where in a cell does glycolysis take place?  
(ii) Name the product of the above process
- (b) Briefly explain Krebs's cycle in a plant cell during anaerobic respiration
9. How is the mammalian skin adapted to its protective function?
10. The oxidation state of a certain food is represented below by a chemical equation:-  
$$2C_3H_7O_2N + 6O_2 \rightarrow (NH)_2CO_2 + 5CO_2 + 5H_2O$$
- a) Calculate the respiratory quotients (**RQ**) of the food substrate
- b) Identify the food substrate
11. Whooping cough is a disease of the respiratory system name the causative agents and give **two** symptoms
12. How does the sunkenness of stomata help in minimizing the rate of transpiration in plants
13. State **two** roles of adrenaline in man
14. Explain why a rat, though small eats more frequently than an elephant
15. Active yeast cells were added to dilute sugar solution in a container. The mixture was kept in a warm room. After a few hours bubbles of a gas were observed escaping from the mixture
- (a) Write an equation to represent the chemical reaction above
- (b) State **two** economic importance of this type of chemical reaction in industry?
16. (a) Give **two** reasons why fats are not the main respiratory substrates in the body of a mammal  
and yet they give a lot of energy when oxidized.
17. The equation below summarizes a metabolic process in plants.  
Glucose  $\rightarrow$  Ethanol + carbon (IV) oxide + Energy  
State **two** industrial applications of the above equation.
18. (a) Differentiate between respiration and respiratory surface.  
(b) Why is an effective respiratory system often associated with a circulatory system.
19. State **two** reasons why lipids are rarely used as a respiratory substrate compound to carbohydrates.
20. The equation below shows respiration for a certain food substrate. Study it and answer questions

that follow:



- (a) Calculate the respiratory Quotient, RQ
- (b) Suggest with reasons the possible food substrate

21. The apparatus below was used to investigate anaerobic respiration:-

- (a) How would you remove dissolved oxygen from the glucose before the experiment commencing?
- (b) State what happens to the lime water as the experiment proceeds to the end
- (c) Describe the reactions in the experiment
- (d) Explain what would happen if the temperature of glucose solution and yeast was raised beyond 45°C?

## 8. Excretion and homeostasis

1. Explain the following:-
  - i) Fresh water fish excrete ammonia
  - ii) Glucose is absent in urine yet present in glomerular filtrate
2.
  - (a) State **two** functions of the kidney
  - (b) Name **two** substances that are not found in urine of a healthy person
  - (c) Name **two** diseases that affect the kidney
3.
  - (a) State **two** structural modification of the kidneys of deserts animals like kangaroo rat.
  - (b) Describe how ingestion of very salty food may reduce the amount of water excreted in urine.
4. A student mixed a sample of urine from a person with Benedict's solution and heated, the colour changed to orange.
  - (a) What was present in the urine sample?
  - (b) What did the student conclude on the health status of the person?
  - (c) Which organ in the person may not be functioning properly?
5. (a) If the human pancreas is not functional:-
  - (i) Name the hormone which will be deficient
  - (ii) Name the disease the human is likely to suffer from
- (b) What is diuresis?
6. State **one** structural adaptation of nephron in the kidney of a desert mammal

7. Name the nitrogenous wastes excreted by the following organisms:-

<b>Animal</b>	<b>Nitrogenous Waste</b>
---------------	--------------------------

- (i) Desert mole
- (ii) Marine fish
- (iii) Tilapia

8. The table below shows description of sizes of glomeruli renal tubules of two animals which are

living in different environments

	<b>Animal X</b>	<b>Animal Y</b>
Glomeruli	Large and few	Small and many
Renal tubules	Short	Long

(a) Name the likely environment in which each animal lives : (i)Animal X  
(ii) Animal Y

(b) What role does vasoconstriction play in thermoregulation?

9. The table below shows the approximate percentage concentration of various components in blood

plasma entering the kidney, glomerular filtrate and urine of a healthy human being

<b>Component</b>	<b>Plasma</b>	<b>Glomerular filtrate</b>	<b>Urine</b>
Water	90	90	94
Glucose	0.1	0.10	0.00
Amino acids	0.05	0.05	0.00
Plasma proteins	8.0	0.00	0.00
Urea	0.03	0.03	2.00
Inorganic ions	0.72	0.72	1.50

(a) Name the process responsible for the formation of glomerular filtrate

(b) What process is responsible for the absence of glucose and amino acids in urine?

(c) Explain why there are no plasma proteins in the glomerular filtrate?

10. What is the importance of sebaceous glands in the human skin?

11. Explain why sweat accumulates on a person's skin in a hot humid environment

12. Distinguish between diabetes mellitus and diabetes insipidus

13. State **two** processes through which plants excrete their metabolic wastes.

14. The figure below shows a vertical section through a mammalian kidney.

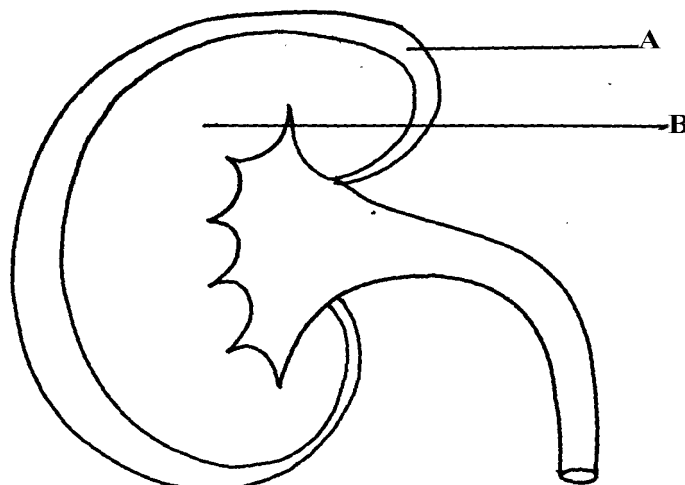

- (a) Label the parts A and B
- (b) Which part is the Bowman's capsule found?
15. (a) Explain the effects of the production of large amounts of Antidiuretic hormone in the human body
- (b) State **two** functions of the loop of Henle
16. Study the homeostatic scheme below:

C

- (a) Identify the hormone labeled **A**
- (b) Name the site of action of hormone **A**
- (c) Identify the feedback labeled **D**
17. State **three** importance of Osmosis in plants
18. A patient was complaining of thirst most of the times. A sample of the patient's urine was found not to contain a lot of sugar but was dilute:-
- (a) Name the hormone the person's body was deficient of
- (b) Which gland produces the above hormone
- (c) Name the disease that the patient was most likely suffering from
19. State **two** features in the nephron that facilitate ultra filtration
20. The table below shows a description of size of glomeruli and renal tubules of two animals which are adapted to living in different environment:-

	Animal A	
Animal B		
Glomeruli and many	large and few	small
Renal tubules long	short	

- a) Name the likely environment in which animal **A** lives



30. The diagram below represents a nephron of a mammal:

(a) Name the parts labeled **A**, **B** and **D**

(b) Name a major substance in glomerular filtrate whose concentration remains the same between **A** and **C**

31. Name the parts of the flower that are responsible for the production of gametes

32. The equation below represents a metabolic process that occurs in a certain organ in the m

mammalian body:-

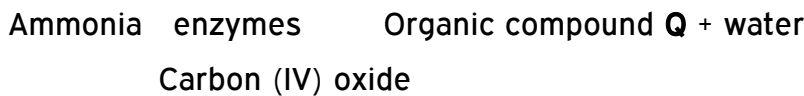

a) Name the process represented in the equation.

b) Name the organ in which the process occurs.

c) Why is the process important to the mammal?

d) Identify the organic compound **Q**.

e) Explain the source of ammonia in the organ named in (b) above.

f) What happens to organic compound **Q**?

33. Kosgei and Onyancha collided during a football match and each got bruised. Kosgei's bruise stopped bleeding after ten minutes while Onyancha's bruise continued bleeding and he had

to be taken to hospital for treatment.

(a) Explain the process which brought about stoppage of Kosgei's bleeding

(b) Distinguish between blood clotting and haemagglutination.

(c) Name the disease, that Onyancha could be suffering from.

34. The table below shows the percentage of some substances in the glomerular filtrate and urine

of a certain mammal:-

Substances	Contents in glomerular filtrate	Contents in urine
Water	90	90
Sodium ions	0.3	0.35
Chloride ions	0.37	0.60
Glucose	0.1	0.0
Urea	0.03	2.0
Proteins	0.0	0.0

(a) From the above table, account for ; (i) The absence of glucose in urine

(ii) The absence of protein in both glomerular filtrate and urine

(b) Explain the significance of the flow system in the nephron where the glomerular filtrate flows in opposite direction to that of blood in the surrounding capillaries

(c) Name the hormone that controls the percentage of water in urine and that which control the amount of salts

Percentage of water  
Amount of salts

(d) List any **two** diseases /disorders of the kidney

35. Study the diagram below and answer the questions that follow

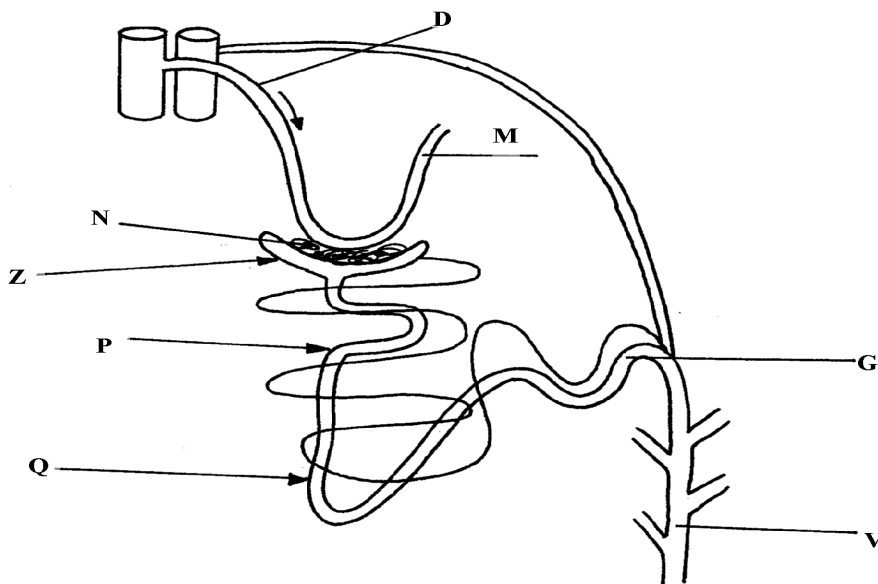

(a) Name the structure represented by the diagram

(b) (i) Name the parts labelled **D** and **M**

(ii) Name the hormones whose sites of action are **Q** and **G**

(c) Name **one** substance that is present in part **N** but absent in part **Z**

(d) The contents of part **V** were boiled with Benedict's solution and an orange precipitate was formed. Account for the results

36. In an investigation, two persons **A** and **B** drank the same amount of glucose solution. Their blood sugar levels were determined immediately and thereafter at intervals of one hour for the next six hours.

The results were as shown in the following table:-

Time (hrs)	Blood glucose level (mg/100ml)	
	Person A	Person B
0	90	120
1	220	360
2	160	370
3	100	380



4	90	240
5	90	200
6	90	160

- (a) Draw a graph of blood sugar levels of persons **A** and **B** against time on the same axis
- (b) Explain each of the following observations;-  
 (i) Blood sugar level increased in person **A** between 0 and 1 hour  
 (ii) The blood sugar level dropped in person **A** between 1 and 4 hours
- (c) From the graph, what is the normal blood glucose sugar level for human beings
- (d) Suggest a reason for the high sugar level in person **B**
- (e) How can the high blood sugar level in person **B** controlled?
- (f) What is the biological significance of maintaining a relatively constant sugar level in a human being
- (g) Account for the decrease in the blood glucose level of person **B** after 4 hours

37. An experiment was carried out to determine the effect of drinking on excess amount of water on

the flow of urine. A person drinks one litre of water and urine was collected at intervals of 15minutes.

The results were as shown below:

Time in minutes	0	15	30	45	60	75	90	105	120	135
Urine output ml/min	1.6	1.6	1.6	5.4	9.0	9.0	7.6	3.0	0.8	0.8

- (a) Plot a suitable graph to represent urine output with time.
- (b) Explain the rate of flow of urine between the following times;  
 (i) 15 and 60minutes.  
 (ii) 60 and 75minutes.  
 (iii) 75 and 135 minutes.
- (c) Name **two** hormones responsible for regulation of relative amount of salts and water in man.
38. a) Explain how urea is formed in the human body  
 b) Describe the path taken by urea from the organ where it is formed until it is released from the human body
39. The diagram below represents a mammalian nephron.

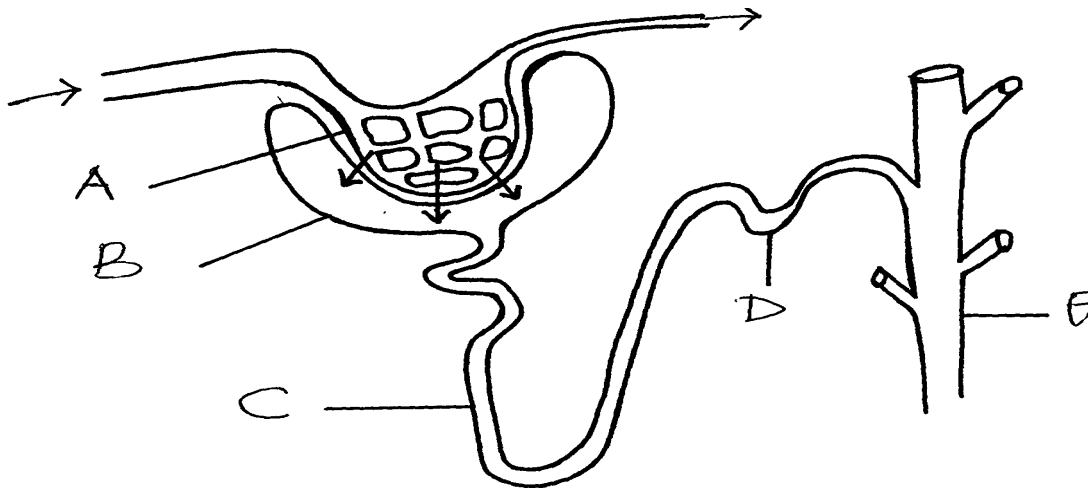

(a) Name the structures labeled B,C and D

(c) Name the process by which substances are reabsorbed from structure C into blood capillaries

(d) How is the pressure in structure A achieved?

40.

a) Identify **substance X**

(c) Give the end products of the process labelled H

(d) Give **three** other functions of the liver

41. The flow diagram below represents blood clotting process

a) Name the proteins represented by the letters; V, Y, Z

b) State the importance of blood clotting

c) Why doesn't the physiological process above occur in undamaged blood vessels

42. How does an Endotherm respond to both heat gain and heat loss?

43. The diagram below represents a mammalian nephron

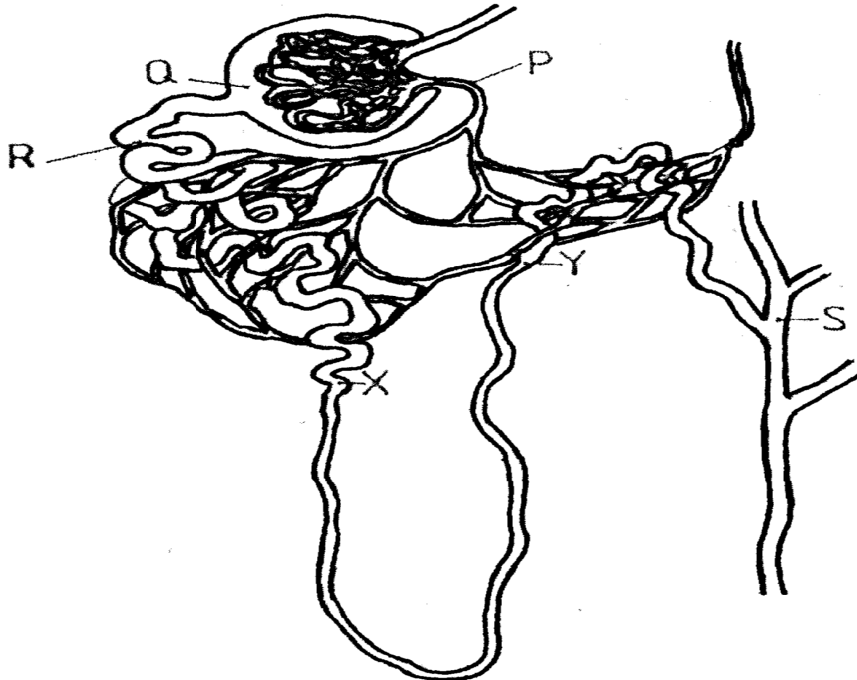

(a) Name the: (i) Structure labelled P

(b) State the structural modifications of the part label led Q for

(i) Desert mammals

(ii) Fresh water mammals

(c) (i) Name **one** substance present at point R but absent at point S in a healthy mammal.

(ii) The appearance of the substance you have named in (c)(i) above is a symptom of a certain disease. Name the disease

44. Describe how the mammalian skin regulates body temperature

## 9. Ecology

1. A student wanted to estimate the number of grasshoppers in 5km<sup>2</sup> grass field near the school compound.

Using a sweep net he captured 36 grasshoppers. He used a red felt pen to mark the thorax of each insect before releasing back into the field. Three days later he made

another catch of grasshoppers. He collected 45 grasshoppers of which only 4 had been marked with red mark.

- a) Name the above method used in the population estimation
  - b) Calculate the population of grasshoppers using the above data
2. What is the significance of the following in the ecosystem?
- a) Decomposers
  - b) Predators
3. Birds feed on grasshoppers that feed on grass.
- a) Draw a possible food chain from the above information
  - b) Explain why the biomass of organisms decreases at each preceding trophic level.
4. Define the following terms:-
- (i) Autecology ;
  - (ii) Biomass;
5. State **two** most important factors that favour exponential growth of a population of gazelle in a park
6. (a) Distinguish between habitat and niche.  
(b) Explain why Biomass of producers is greater than that of primary consumers in a balanced ecosystem.  
(c) State **two** advantages of a biological control method over the chemical control method of pests and parasites
7. Explain how oil as a pollutant may affect aquatic plants and animals?
8. The diagram below shows part of a food relationship in an ecosystem:-
- (a) Name the food relationship above
  - (b) How many trophic levels are shown in the diagram above?
  - (c) State main source of energy in the ecosystem
9. Use the food web below to answer the questions that follow:-

- (a) Construct a food chain ending with crocodile as a quaternary consumer  
(b) Name the organisms in the food web that has only one predator
10. 50 black mice and 50 white mice were released in an area inhabited by a pair of owls.

After

four months, the mice in the area were recaptured and only 38 black mice and only a white mouse remained.

- (a) How would you explain these results?  
(b) Name the theory of evolution that supports the results in (a) above
11. In a certain school Form three class did an experiment to estimate the number of

Tilapia

in their fish pond. 725 tilapia were netted, marked, and released.

- a) State the method used in this exercise  
b) Calculate the tilapia population.  
c) State **two** assumptions made by the students during the investigation
12. An investigation was carried out on a terrestrial ecosystem. The population sizes and species

biomass were determined and recorded as shown in the table

SPECIES	POPULATION SIZE	SPECIES BIOMASS
A	$1 \times 10^3$	$1 \times 10^3$
B	$1 \times 10^3$	$1 \times 10^{-1}$
C	$1 \times 10^5$	$1 \times 10$
D	$1 \times 10$	$1 \times 10^4$

- a) If these organisms had a feeding relationship, construct a simple food chain involving all the organisms  
b) Construct a pyramid of numbers using the data provided above  
c) State **one** disadvantage of using a pyramid of numbers in expressing feeding relationships in an ecological ecosystem
13. The figure represents a feeding relationship in an ecosystem

- (a) Write down the food chain in which the Guinea Fowls are secondary consumers  
(b) What would be the short-term effects on the ecosystem if lions invaded the area?  
(c) Name the organism through which energy from the sun enters the food web

14. Outline **three** roles of active transport in human body
15. Distinguish between community and population
16. Describe how the belt transect can be used in estimating the population of a shrub in a grass land
17. A fish farmer wanted to know the number of fish in a pond. He collected 10 fish from the pond and labeled each, by a tag label on its fin and returned the ten fish to the pond to mix with other fish . When he later collected 50 fish from the pond, he found only four of them had labels
  - a) Estimate the total number of fish in the pond (show your workings)
  - b) What **two** assumptions are being made in this methods of estimating population
18. What is the importance of saprophytic fungi and bacteria in an ecosystem
19.
  - i) Name **one** main cause of global warming
  - ii) What are the effects of global warming
20. Explain how saliva is important in digestion
21. Give a reason why two species in an ecosystem cannot occupy the same niche
22. Below is a pyramid of numbers indicating trophic levels:-

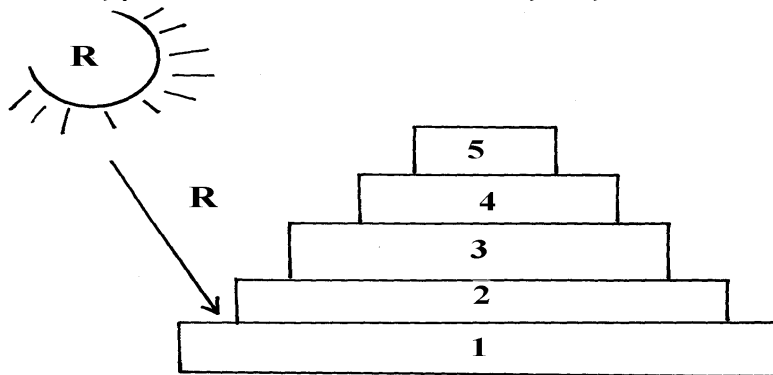

- (a) What do you understand by the term trophic level?
- (b) Name the trophic level numbered 5 on the pyramid
- (c) Name **Q**
- (d) What is the significance of the arrow **R**
23. Two populations of the same species of birds were separated over a long period of time by an ocean. Both populations initially fed on insects only. Later, it was observed that one population fed entirely on fruits and seeds, although insects were available. Name this type of evolutionary change
24. To estimate the population size of crabs in a certain lagoon, traps were laid at random. 400 crabs were caught, marked and released back into the lagoon. Four days later, traps were laid again and 360 crabs were caught. Out of the 360 crabs, 90 were found to have been marked
  - (i) Calculate the population size of the crabs in the lagoon
  - (ii) What is the name given to this method of estimating the population size
25. State the function of each of the following apparatus:
  - (a) Pooter ...
  - (b) Sweep net .....

26. State the role of the following apparatus in the study of living things.  
 (a) Sweep nets.  
 (b) Pooter.  
 (c) Pit fall trap.
27. Name **three** density dependent factors in an ecosystem.
28. (a) What are the **two** main components of an ecosystem?  
 (b) Apart from mere observation of actual feeding suggest **two** methods that can be used to determine the type of food eaten by animals
29. The chart below represents a simplified nitrogen cycle.

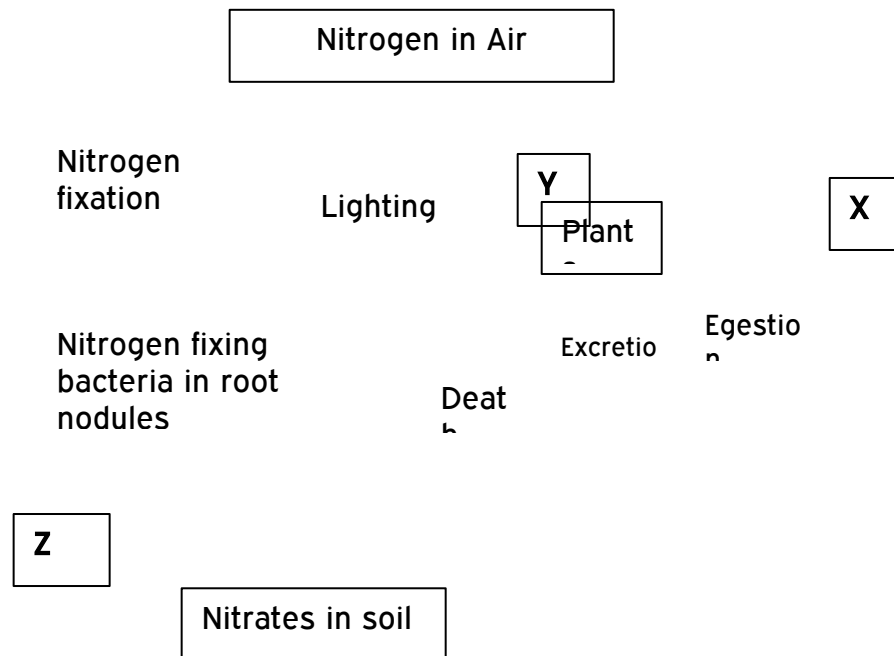

What is represented by X, Y and Z?

30. In an ecological study, a locust population and that of crows was estimated in a grassland area over a period of one year. The results were tabulated as shown below.

Months	J	F	M	A	M	J	A	S	O	N	D
No. of Adult locusts x 10 <sup>2</sup>	90	20	11	25	200	652	15	10	35	192	456
Number of crows	4	2	0	1	8	22	2	1	1	5	15
Amount of rainfall	20	0	55	350	520	350	10	25	190	25	350
								5		6	

- a) Draw a graph of population of locusts and crows against time
- b) i) State the relationship between rainfall and locust population  
 ii) Account for the relationship you have stated in b (i) above
- c) What happens on the populations of locusts and crows in the months of January to March?  
 Give a reason.
- d) If the area of study was one square kilometer, state **one** method used to estimate the population of :- i) Locusts  
 ii) Crows
- (e) (i) State the trophic levels of the (i) Locusts and (ii) crows  
 (ii) Construct a simple complete food chain involving these organisms
- (f) If the locust were removed from the food chain, what would be its effect?

(g) Define **biomass**

31. Two species of antelopes were introduced into an ecosystem at the same time in equal numbers.

The graphs below show their relative numbers during the first eight years of their co-existence.

Study the graphs carefully and answer the questions that follow.

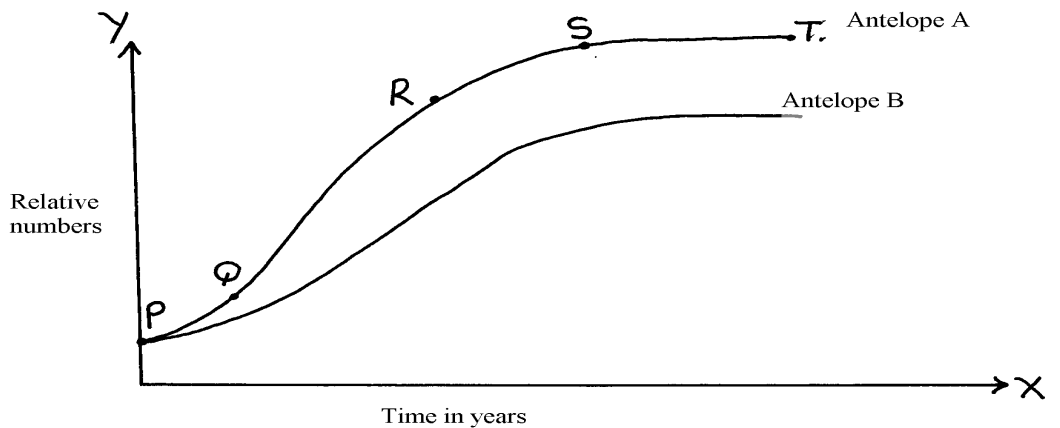

- a) i) Which species of antelope has better survival adaptations.  
ii) Give a reason for your answer above.
  - b) i) Name the type of curves shown.  
ii) Name the phases labeled PQ, QR, RS, ST
  - c) Explain the shape of the curve for the species of Antelope A between
    - i) Q and R.
    - ii) S and T.
  - d) i) State the type of competition shown by the two species of antelopes.  
ii) State any **two** symptoms of intraspecific competition in plants.
  - e) Suggest how the species B avoid competitive exclusion..
  - f) State any **three** adaptations that enable the antelopes to overcome predation.
  - g) State any **two** possible methods by which populations of the two antelopes' species were determined.
32. Explain **five** abiotic factors that affect the ecosystem
33. The data shown below was taken from Savannah grassland habitat. Examine it carefully and then answer the questions that follow:-
- (a) Draw **three** food chains
  - (b) Draw a pyramid of numbers for a food chain with four trophic levels and indicate the trophic levels at which each member feeds
  - (c) State the effect of removing the hunting dogs
  - (d) Why is it advisable to feed 100kg of grain to man instead of using it to fatten steers then supply beef to human population?



Grasses	1000
Caterpillars	500
Squirrels	300
Frogs	200
Gazelles	300
Elephants	100
Snakes	50
Hunting dogs	40
Vultures	40
Lions	40
Hawks	10

34. Study the following food web and answer questions that follow:

- (a) (i) Name the organisms that occupy the second trophic level  
(ii) What is the other name for the second trophic level
  - (b) Write down **two** food chains from the food web that:
    - (i) End with hawks as tertiary consumer
    - (ii) End with hawks as quaternary consumer
  - (c) Giving reasons state; (i) the organism with largest biomass  
(ii) the organism with least biomass
35. (a) Explain how food as a factor regulates the population of animals in an ecosystem  
(b) Describe the flow of energy from the sun through the different trophic levels in an ecosystem
36. (a) Describe how a population of grasshoppers in a given area can be estimated  
(b) Describe how the belt transect can be used in estimating the population of a shrub in a grassland
37. The flow chart below represents a feeding relationship in an ecosystem

- (a) Name; (i) The producers in the ecosystem  
(ii) Two organisms which are both secondary and tertiary consumers
- (b) State **two** short term effects of immigration of insects in the ecosystem.
- (c) Which organism has the least Biomass in the food web. Explain.
- (d) State **three** disadvantages of using synthetic pesticides over Biological control.
- (e) State the role of each of the following in an ecosystem;  
(i) Saprophytes  
(ii) Leguminous plants  
(iii) Explain the role of producers in an ecosystem
- (f) Name **one** method that would be used to estimate the population of small fish in the ecosystem
38. How are leaves of mesophytes adapted to their functions?

## 10. Reproduction in (a) plants (b) animals

1. a) Name the part of an ovule that develops into each of the following parts of a seed after fertilization  
i) Testa  
ii) Endosperm
- b) What is parthenocarpy?
2. State **three** roles of placenta during pregnancy.
3. Name **three main** methods through which HIV/AIDS is transmitted
4. (a) Name the processes that lead to fruit formation without fertilization  
(b) Name the hormone that causes leaf, flowers and fruit abscission  
(c) What is the role of ecdysone hormone in insects
5. State the roles of oviduct in female reproductive system
6. The diagram below represents a mature embryo sac. Study it carefully and answer the questions

that follow:

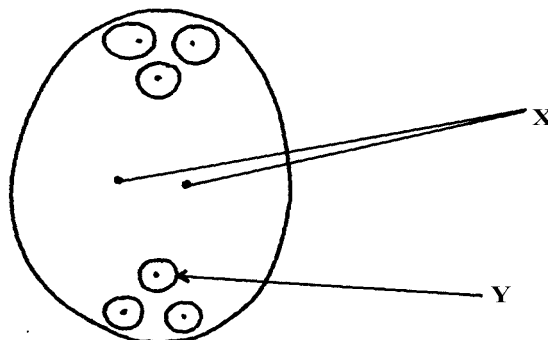

- (a) Identify structures X and Y

(b) Why is cross pollination more advantageous to a plant species than self pollination?

7. The diagram below shows a phenomenon which occurs during cell division.

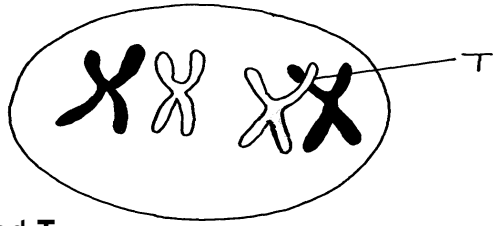

(a) Name the part labeled T.

(b) (i) State the biological importance of the part labelled T.

(ii) Identify the type of cell division in which this phenomenon occurs.

8. (a) When are the **two** organisms considered to belong to the same species.

(b) Explain the term **alternation of generations**.

9. (a) Explain why Larmack's Theory of evolution is not accepted by biologists today.

(b) State the significance of mutation in evolution.

10. (a) Give **two** roles of the placenta.

(b) Explain why hormone testosterone still exerts its influence even when vas deferens have been cut.

11. Name **two** mechanisms that hinder self fertilization in flowering plants

12. State **three** ways in which plants compensate for lack of movement

13. (a) What do you understand by the term double fertilization?

(b) State **two** adaptations of animal dispersed fruits

14. Name the hormone that;

(a) Stimulate the contraction of uterus during birth

(b) Stimulates the disintegration of the corpus inteum when fertilization fails to take place

15. State **three** ways in which flowers parent self pollination

16. The diagram below represents a stage in the development of human foetus

(a) State **one** function of each of the structures labelled **A** and **B**

(b) Apart from the size of the foetus what else from the diagram illustrates that birth was going to occur in the near future

(c) Explain why a pregnant woman is supplied with doses of iron tablets regularly

17. Name the type of placentation where;

(i) Placenta appears as one ridge on the ovary wall

(ii) Placenta appears at the centre of the ovary with ovules on it and the dividing walls

of carpels

disappear

18. The diagram below represents a mature fruit from a dicotyledonous plant, observe it and

answer questions that follow

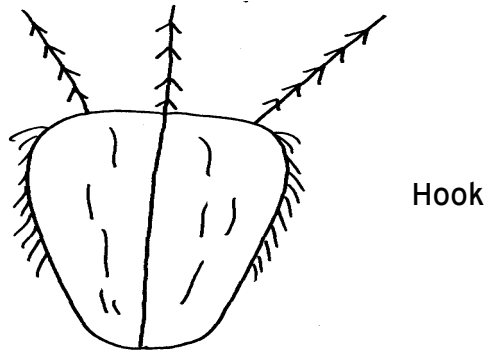

- a) To what group of fruits does the specimen belong?
  - b) Suggest the possible agent of dispersal of the fruit
19. Explain why menstrual periods stop immediately after conception?
20. a) Why is sexual reproduction important in evolution of plants and animals  
 b) The calyx cells of a certain plant has 22 chromosomes. State the number of chromosomes present in the plant's

- i) Endosperm
  - ii) Ovule cell
21. The diagram below shows a pollen – tube entering the ovule of a flowering plant

A

D

- a) Name the parts labeled **A**, **B** and **D**
  - b) Name the kind of fertilization exhibited by the above flowering plant.
22. Donkey and zebra are closely related yet not of the same species. Explain
23. Name **two** factors in the environment which organisms respond to
24. What is meant by the terms:- a) i) Epigynous flower

- ii) Staminate flower
- b) Name the protective membranes surrounding the

brain

25. The diagram below illustrate a process in a given species of organism

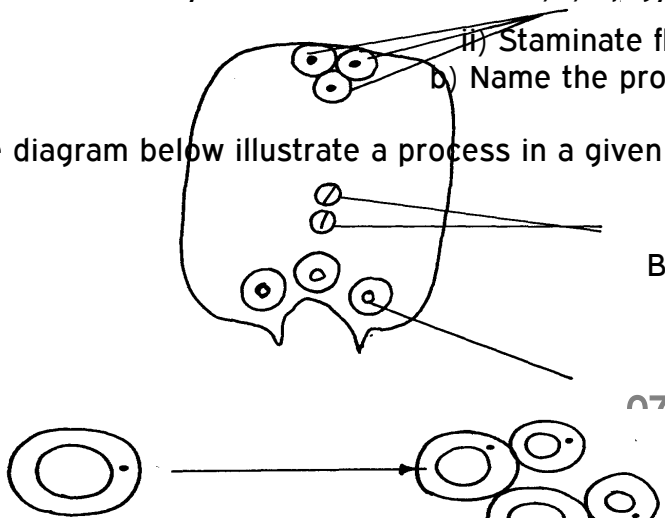

- a) Name the organism that undergoes the process above  
b) Identify the process shown to be taking place
26. State **two** ways by which HIV/AIDS is transmitted from mother to child
27. (a) State the role of centrioles during cell division  
(b) (i) Explain the role of chlorophyll in photosynthesis  
(ii) What is the **main** product of the dark stage of photosynthesis?
28. (a) At what stage of meiosis is the chiasmata formed?  
(b) (i) What is the significance of the above part in living organisms?  
(ii) State **two** importance of meiosis in living organisms?
29. (a) State **two** ways in which the male parts of a wind pollinated flower are adapted to their mode of pollination  
(b) Differentiate between monoecious and dioecious plants
30. (a) What is seed dormancy?  
(b) State **two** ways in which seed dormancy can be broken
31. (a) Explain **two** importance of the adult stage in metamorphosis in insects  
(b) What is the importance of the juvenile hormone in insects?
32. Describe the possible effects of discharging hot effluent from a factory into a slow flowing river
33. State **two** disadvantages of external fertilization in animals
34. State **three** roles of placenta in mammals
35. (a) The diagram below shows a stage during cell division

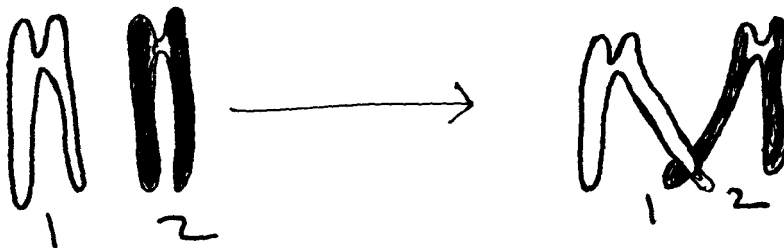

- (i) Name the stage of cell division  
(ii) Give a reason for your answer
- (b) Name **two** structures in plants where male and female gametes are produced
36. State **two** advantages of metamorphosis to the life of insects
37. List **four** differences between Mitosis and Meiosis
38. Give a reason why two species in an ecosystem cannot occupy the same niche
39. State the functions of the following hormones in the menstrual cycle :  
(i) oestrogen  
(ii) luteinizing hormone (L.H)  
(iii) Follicle stimulating hormone (FSH)
40. The diagrams below represent two gynoecia **A** and **B** obtained from two different plants.

- (a) What name is given to; Gynoecium **A**?  
Gynoecium **B**?
- (b) State the observable difference between the gnoecia **A** and **B**
- (c) State the role played by Heterostyly in plants.
41. State the difference between the sperm cell and the ovum.
42. (a) Name the parts of the flower in which pollen grains are formed.  
(b) Name **two** nuclei found in pollen grains.
43. The diagram below represents a stage in cell division.
- (a) Name the stage of cell division shown in the diagram above.  
(b) Give reasons for your answer.
44. Name the hormone that:
- (a) Stimulate the contraction of uterus during birth.  
(b) Stimulate the disintegration of corpus luteum when fertilization fails to take place.
45. State **three** ways in which seed dormancy benefits a plant
46. (i) State **two** major structural differences between fruit and a seed  
(ii) Why is it advisable to use biological control of pests?
47. State the functions of the following parts in the male reproductive system
- (a) Spermiferous tubules  
(b) Sertoli cells
48. (a) Name the parts of a flower responsible for gamete formation  
(b) State **one** feature of pollen grains from a wind pollinated flower
49. Name the mechanisms that hinder self-fertilization in flowering plants
50. The eggs of birds are relatively much larger than those of mammals. Explain
51. Distinguish between the following terms:
- Pollination and fertilization**
52. a) Describe the various mechanisms of fruit and seed dispersal.  
b) Describe the varying events that follow a flower after fertilization.
53. Describe how fruits and seeds are suited to their mode of dispersal
54. The diagram below represents some hormones, their sources and functions in a mammal:
- (a) Identify the master gland described above

- (b) Name hormones (ii), (iii), (v) and (iv)
  - (c) Explain the consequences of deficiencies of hormone (ii) in man
  - (d) Other than stimulating the development of uterine wall, suggest one other function of hormone (vi)
55. The diagram below represents some hormones, their sources and functions in mammals.

- ) Name the hormones I, II and III
- b) Name hormones IV and state its function
- c) Name the control labelled A & B
- d) Name **one** secondary sexual characteristic common to both males and females

56. (a) State the role of spleen in human defense mechanism
- (b) State **two** ways by which the HIV spread may be controlled through patients in hospitals
- (c) What do you understand by the word Acquired Immunity Deficiency Syndrome (AIDS)
- (d) Why is immunization against diseases encouraged by the government
- (e) State how natural active acquired immunity is attained by an individual

57. Explain how seeds and fruits are adapted to the various methods of dispersal

58. The diagram below represents female reproductive system;

- a) Name the part labeled; A, B, C and D
- b) State **two** functions of structure A
- c) How is part C adapted to its function?
- d) Of what significance is part E to reproduction?

59. The diagram below represents a human foetus in a uterus

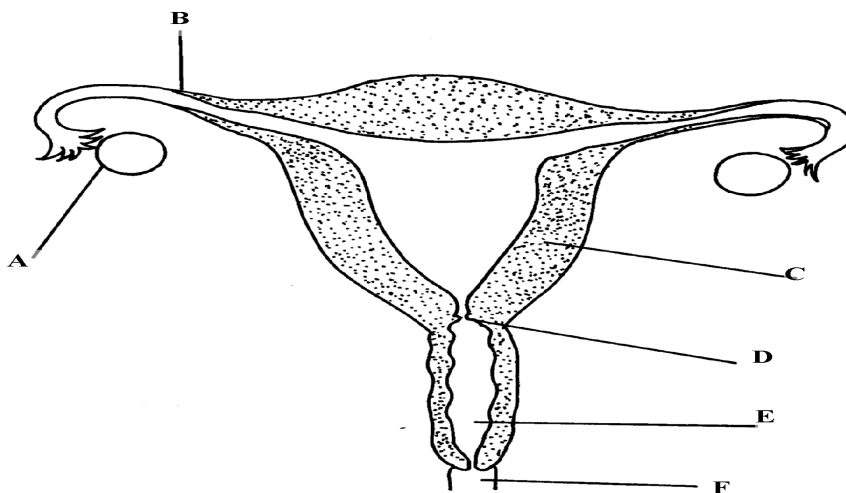

- (a) Name the part labelled S
- (b) (i) Name the blood vessels labelled A and B

- (ii) State the difference in composition of blood found in vessels **A** and **B**
- (c) Name **two** features that enable the structure labelled **P** carry out its function
- (d) State the role of the part labelled **R**

60. An experiment was carried out to investigate the rate of growth of pollen tube against time.

The results are shown in the table below:

Time in minutes	Growth of pollen tube in millimeters
0	0
30	4.0
60	9.8
90	15.2
120	20.0
150	21.6
180	22.4

- (a) (i) On the grid provided draw a graph of the pollen tube growth against time.
- (b) (i) At what intervals was the growth of the pollen tube measured?
  - (ii) What was the length of pollen tube at; 130 minutes
  - (iii) At what time was the length of the pollen tube 18mm?
  - (iv) With reasons, describe the growth pattern of the pollen tube between:
    - 0 to 120minutes
    - Reason
    - 120 to 180 minutes
    - Reason
  - (v) State the importance of the growth of pollen tube to the plant
- (c) State the changes that take place in a flower after fertilization

### 11. Growth and development in (a) plants (b) animals

- 1. a) Name the hormone which controls moulting in insects.
- b) State the importance of moulting in insects.
- 2. The illustration below represents an eye defect

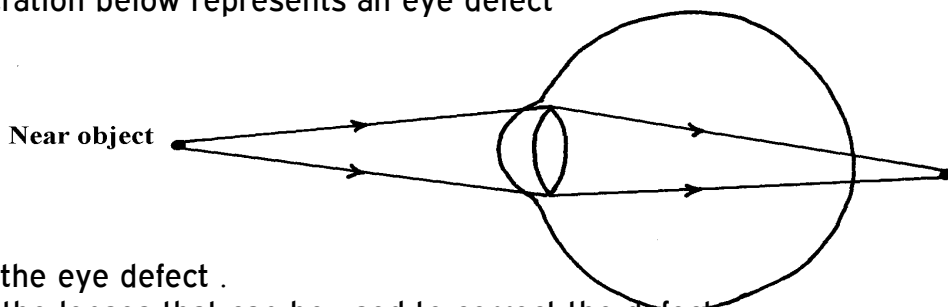

- a) Name the eye defect .
- b) Name the lenses that can be used to correct the defect.
- 3. (a) State **two** functions of the kidney
- (b) Name **two** substances that are not found in urine of a healthy person
- (c) Name **two** diseases that affect the kidney
- 4. The diagram below represents a growth pattern of arthropods.



Time (days)

- (a) Name the type of growth pattern represented on the graph.  
 (b) Identify the process represented by X.  
 (c) Which hormone is responsible for process at X in 15 (b) above?

5. Distinguish between natural and acquired immunity.  
 6. The cells shown below were obtained from different parts of a young root tip:

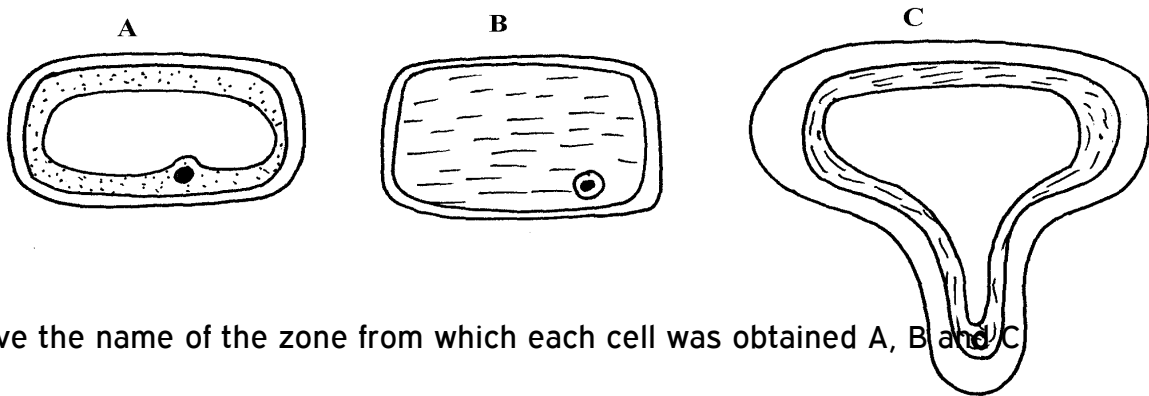

Give the name of the zone from which each cell was obtained A, B and C

7. Differentiate between continuous and discontinuous variations  
 8. An experiment was set-up as shown in the diagram below:-

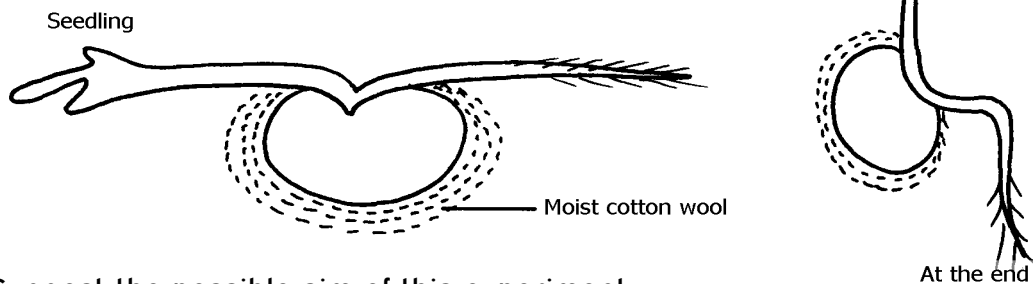

- (a) Suggest the possible aim of this experiment  
 (b) Account for the observation at the end of the experiment

9. State the location of **each** of the following plant meristematic tissues:-

- (i) Vascular cambium  
 (ii) Intercalary meristem

10. Define the following terms: a) Growth  
 b) Development

11. State **two** advantages of metamorphosis in the life insects

12. State **one** disadvantage of exoskeleton in insects.

13. Distinguish between primary growth and secondary growth in a flowering plant

14. What is the role of the following to a germinating seed: (i) Oxygen  
 (ii) Cotyledons

15. Give **three** applications of plant growth hormones in agriculture

16. State **two** functions of calcium in the human body
17. State the biological importance of ecdysis in arthropods
18. The diagram below represents a stage during the process of germination.
- (a) (i) Name the type of germination illustrated in the diagram  
(ii) Give a reason for your answer in (a) (i) above.
- (b) Give **two** functions of the part labelled X
19. In an experiment young potted seedlings were placed in a dark box with unilateral light source  
as shown below:
- (a) What was the aim of the experiment?  
(b) State the observations made on the seedlings after 3 days
20. The graph below represents the growth of animals in a certain phylum.
- (a) Name the type of growth pattern shown on the graph.  
(b) Identify the process represents by x.  
(c) Name the hormone responsible for the process in B above.
21. (a) State the role of the vascular cambium in plant growth and development.  
(b) Explain why monocotyledons plants do not undergo secondary thickening.
22. Explain how placenta is adapted to its functions
23. State the role of the following during germination:  
(a) oxygen  
(b) enzyme
24. Name the type of responses exhibited by:-  
(a) (i) Marine crabs burrowing into the sand to avoid dilution of their body fluids  
(ii) Chlamydomonas plant moving towards a region of high light intensity  
(b) (i) What type of neuron is drawn above?  
(ii) Using an arrow, show the direction of the nerve impulse  
(iii) Name the part labelled X

(iv) State the function of part labelled Y .

(c) Give **two** differences between reflex action and conditioned reflex action

25. The experiment set – up below was designed to investigate an aspect of germination.

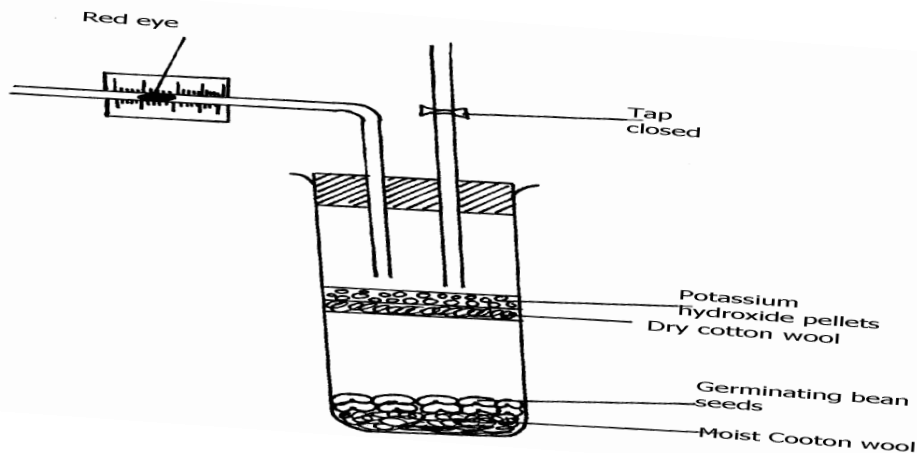

a) Why was potassium hydroxide pellets used in this experiment?

b) What was the role of moist cotton wool in this experiment?

c) i) By means of an arrow, indicate on the diagram the direction in which red dye would move during the experiment.

ii) Give reason for your answer in c(i) above.

d) Other than the factor investigated above, state any other **one** factor necessary for germination process.

26. The following data represents the development in dry mass of germinating seedlings within 18

weeks:

Time in weeks	0	1	2	4	6	10	13	15	16	18
Dry mass in grammes	0.1	2	3.2	10	18	32	44	45	44	38

(a) Using suitable scales plot a graph of dry mass against time

(b) Write reference to the graph, explain the changes in dry mass between:-

(i) Week 0 to 2

(ii) Week 5 to 13

(iii) Week 16 - 18

(c) (i) What is the significance of time zero?

(ii) What difference would be expected from the above results if the experiment started with

the seeds? Give a reason for your answer

(d) (i) Describe how you carry out the experiment to obtain dry mass in the respective weeks

(ii) State **one** advantage of using dry mass instead of fresh weight in estimating growth of an organism

27. The diagram below represents a set-up that was used to investigate the effect of rotation on the

growth of a bean radicle. The set-up allowed the seedling to rotate slowly and

continuously for  
seven days

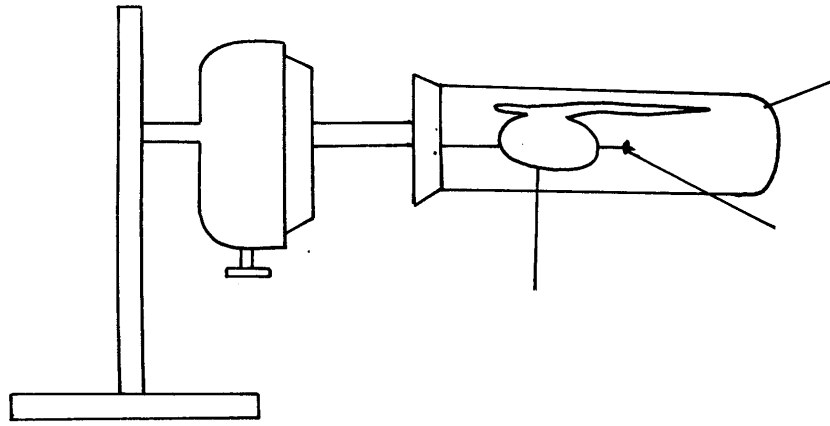

- (a) Name the piece of apparatus illustrated
  - (b) (i) State the observation made on the shape of the radicle after seven days
  - (ii) Explain the observation in (b) (i) above
  - (c) Suggest a suitable control for this experiment
  - (d) Give any **four** importance of tropism in plants
28. An experiment was carried out to determine the growth rates of variety of bamboo and a variety of maize in two adjacent plots. The average height and average dry weight of plants from the two populations were determined over a period of twenty weeks. The data is as shown below:-
- a) On the same axes, plot a graph to show the changes in average weight of the bamboo and maize plants over time
  - (b) (i) Which of the two plants had a higher productivity by the end of the experiment?
  - (ii) Give a reason for your answer in (b)(i) above
  - (c) Explain the following:
    - (i) Between weeks 14 and 18 the average height of maize plants remained constant while the average dry weight increased
    - (ii) Dry weight was used instead of fresh weight in this experiment
    - (iii) Describe how the average height and average dry weight of plants were determined in this experiment;
  - (d) Why was it appropriate in this experiment to use both weight and height?
  - (e) Give a reason why secondary thickening does not occur in bamboo and maize plants
29. (a) What is meant by the term **fertilization** ?
- (b) (i) Name the type of cell division that produces gametes
  - (ii) Where does the type of cell division mentioned above occur in mammals?
  - (c) What happens to the wall of the uterus;
    - (i) before the release of an egg ?
    - (ii) if no fertilization occurs?
  - (b) How is the placenta adapted to its functions?
30. The relationship between seed fresh mass in the lupin *lupinus* and percentage seed

germination,

percentage seedling survival and seedling fresh mass is shown in the table;

Seed fresh Mass mg <sup>-1</sup>	Percentage germination	Percentage of seedlings surviving 2 leaf stage	Mean seedling fresh mass 5 weeks after germination/mg
Below 16	41.9	84.6	24.3
17-25	90.2	96.8	44.2
26-35	95.6	98.8	60.7
36-45	97.5	100.0	86.4
Above 45	100.0	100.0	106.4

a) How was percentage germination in column two of the table calculated?

b) Why was seed fresh mass preferred to seed dry mass to take measurements of the seed weight in the experiment

c) i) Explain why the measurements of mean seedling fresh mass (5) weeks after germinated

may not have been an accurate measurement of growth that had occurred

ii) How could more meaningful and accurate measurement been obtained in c(i) above?

d) With reference to the figures in the table indicate the relationship between seed fresh mass

and percentage seed germination, percentage seedling survival and seedling fresh mass

e) Suggest an explanation why seedling produced from large seeds grow more rapidly than the

seedling produced from small seeds

31. The diagram below illustrate enzyme controlled reaction

a) State the relationship between rate of reaction and enzyme concentration

b) Account for the rate of reactions between; i) Q and R

ii) R and S

iii) U and V

c) Name **one** other factor that affects enzyme action, not illustrated above

32. Carefully study the figure below and answer the questions that follow:-

The seedling with straight radicle and plumule was attached to a machine horizontally as shown

above. The machine rotates making one revolution in 15minutes.

(a) Draw how the seedling would look like after one week

(b) Explain your drawing in (a) above

(c) Name the machine used in the experiment above

(d) What would happen if the seedling was put horizontally outside the machine

(e) Name the stimuli investigated and type(s) of response expected in the experiment

33. (a) Give the form in which each of the following substances are transported in mammalian blood:

(i) Carbon (IV) oxide

(ii) Oxygen

(b) Give **two** functions of pleural membrane

(c) Explain why formation of carboxyhaemoglobin in the blood of a mammal results in death

(d) Other than stomata, name **two** other gaseous exchange surfaces in plants

34. In an experiment the radicle of a seedling was marked equidistant using Indian ink as shown

in the diagram below:

(a) What was the aim of the experiment?

(b) On the diagram below mark on the radicle to show the appearance of the marks after 3days

(c) State **three** characteristics of cells found just behind the root cap of a radicle

(d) Give **two** factors inside a seed that causes seed dormancy

## 12. Genetics

1. A woman with blood group **A** gave birth to twins both having blood group **AB**.  
Determine the genotype of:
  - a) Father
  - b) Mother
2. 50 black mice and 50 white mice were released into an area inhabited by a pair of owls. After four months, the mice in the area were recaptured and only 38 of the black mice and 9 of the white mice were remaining.
  - a) How would this observation be explained ?
  - b) Name the theory of evolution that supports the results in (a) above.
3. State **three** mechanisms that prevent self pollination in a flower that has both male and female Parts.
4.
  - (a) Distinguish between complete and incomplete dominance
  - (b) State **two** sources of variation
5. Part of one strand of a DNA molecule was found to have the following base sequence.  
G – T – C – A – G – T
  - (a) What is the sequence on m-RNA strand copied from this DNA portion?
  - (b) State **two** roles of DNA molecule.
6. State **three** ways by which plants compensate for lack of ability to move from one place to another.
7. A student mixed a sample of urine from a person with Benedict's solution and heated, the colour changed to orange.
  - (a) What was present in the urine sample?
  - (b) What did the student conclude on the health status of the person?
  - (c) Which organ in the person may not be functioning properly?
8. Differentiate between continuous and discontinuous variations
9. Members of the same species of organism tend to differ due to variation. State **three** causes of variation in organisms
10. Identify the type of gene mutations represented by the following pairs of words:-
  - (i) Shirt instead of skirt
  - (ii) Hopping instead of shopping
  - (iii) Eat instead of tea
11. A DNA stand has the following base sequence: GCCTAGATCAC  
What is the sequence of the :
  - (i) Complementary DNA strand?
  - (ii) M-RNA strand coped form this DNA strand
12. The figure below represents the distribution of height of pupils in a school

- (a) Name the type of variation represented by the curve  
 (b) Outline **two** possible causes of variation in height of individuals in man
13. a) Wekesa and Wanjiku who are siblings are both normal as their parents but have a hemophilic brother. Give the Genotype of their parents.  
 b) i) What are linked genes?  
 ii) What do you understand by the phrase a test cross?
14. There are at least 205 known sex – linked recessive disorder  
 a) Name **any two** of them.  
 b) State a reason why sex – linked recessive why traits tend to effect the male child.  
 c) State why if a mother has the trait all her sons will have it
15. The table below is a representation of a chromatide with genes along its length. It undergoes

mutation to appear as shown below:

Before mutation	L	M	N	O	P	Q
After mutation	L	O	N	M	P	Q

- a) Name the type of chromosomal mutation represented  
 b) Name **one** mutagenic agent
16. The figure below is a structural diagram of a portion from a nucleic acid strand  
 a) Giving a reason, name the nucleic acid to which the portion belongs  
 b) Write down the sequence of bases of a complementary DNA strand
17. In an experiment, plants with red flowers was crossed with plants with white flowers. All the plants in the **F<sub>1</sub>** generation had pink flowers.  
 a) Give a reason for the appearance of pink flowers in the **F<sub>1</sub>** generation  
 b) If plants in **F<sub>1</sub>** were selfed, state the phenotypic ratio of the **F<sub>2</sub>** generation  
 c) Explain; i) Why women should drink extra milk during pregnancy  
 ii) A pregnant women might want to urinate more often in late pregnancy
18. State the meaning of the following terms giving an example in each case:  
 (a) Sex-linked genes  
 (b) Multiple alleles
19. In a certain breeding experiment, a plant species with red flowers was selfed. It produced **119**  
**red** flowered and **41 white** flowered offsprings.  
 (a) Using letter **R** to represent allele for the red flowers, state the genotype of the red flowered  
 parent plant



(b) Determine the phenotypic ratio of red and white flowered plants. Show your working

20. Give an example of a sex-linked trait in human on:

(i) **Y** – Chromosome

(ii) **X** – Chromosome

21. Explain why growth of long hair on the pinnae of the ears in human occurs in males only

22. Explain why **prophase 1** of meiosis contributes towards genetic variation in living organisms.

23. A pure Red flowered plant was crossed with a pure white flowered plant. All the  $F_1$  generation

plants had pink flowers.

(a) Give an explanation for the absence of Red and white flowered plants in the  $F_1$  generation. (b) If the  $F_1$  generation pea plants were selfed, state the phenotypic ratio of the  $F_2$  generation plants.

24. (a) Name a genetic disorder due to gene mutation that affects the malpighian layer of the skin in man.

(b) Give **two** functions of the fluid produced by sebaceous glands.

25. (a) Define the term "Gene mutation."

(b) Name the genetic disorders that result from gene mutation in human beings.

26. (i) What are mutations

(ii) Name **two** mutagens

27. A section of a DNA strand contains the following sequence CCGATAC

(a) Write the; (i) Complementary DNA strand

(ii) mRNA strand

(b) Name the site for protein synthesis in a cell

28. In a certain bird species, red flight feathers is controlled by gene **R** while white flight feathers is

controlled by gene **r**. The heterozygous condition **Rr** results into pink flight feathers.

The two

genes are also sex linked and transmitted on x-chromosome.

a) By use of fusion lines, find the genotypes of across between a male with pink flight feathers and a female with white flight feathers

b) Which type of dominance is illustrated here?

c) i) Identify the nucleic acid whose base sequence is shown below:

G-A-C-U-A-G-A-C-G

ii) Give a reason for your answer in **c (i)** above

iii) If the nucleic acid was involved in protein synthesis, how many amino acids would be

present in the protein synthesized? Give a reason

29. Study the genetic chart below showing the inheritance of the gene responsible for haemophilia

in a family.

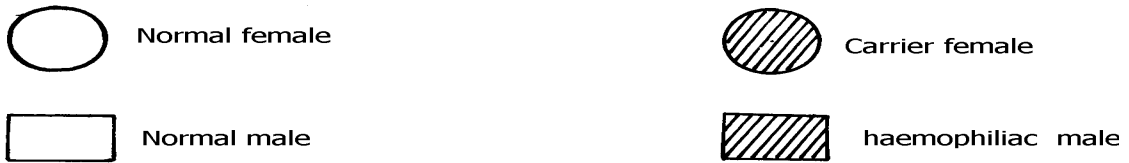
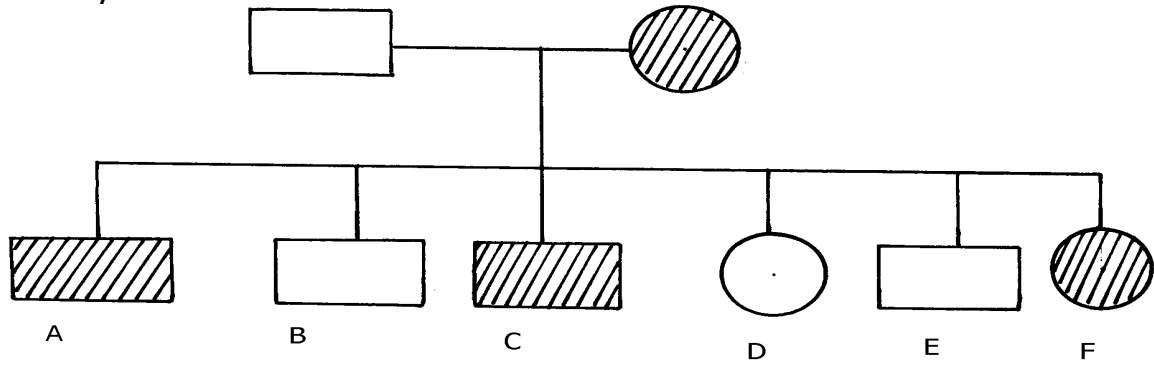

a) Write the genotype of individuals A, B, F

b) A member of this family labelled F marries a haemophiliac male. What will be the phenotypic

ratio of the offspring? Show your workings

c) Other than the condition stated above, state any other **two** common genetic disorders that result from gene mutation.

30. Haemophilia is due to a recessive gene. The gene is sex-linked and located on X chromosome.

The chart below represents the offspring of parents who are phenotypically normal for haemophilia

(i) What are the parental genotypes?

Explain your answer in (i) above

(ii) Work out the genotypes of the offspring

31. A cross between a red-flowered and a white flowered plant produced only pink-flowered

F<sub>1</sub> plants

- (a) There was neither a red nor white –flowered F<sub>1</sub> plants. Explain  
 (b) The F<sub>1</sub> offspring were selfed to get F<sub>2</sub> generation. Using appropriate letter symbols, work out the genotypes of F<sub>2</sub> generation  
 (c) Give the genotypic and phenotypic ratios of F<sub>2</sub> generation  
 (d) Distinguish between dominant and recessive genes
32. A true-breeding purple maize variety was cross-pollinated with a true-breeding yellow maize variety.

The offspring produced all purple fruits.

The plants grown from these F<sub>1</sub> grains were interbred among each other.

A typical cob of F<sub>2</sub> generation is shown below:

The yellow fruits are shaded while the purple ones are un-shaded.

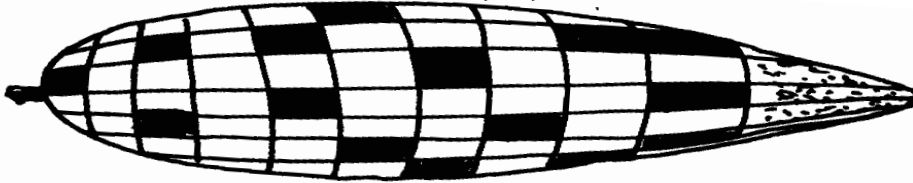

- (a) (i) In terms of flowers only, state why it is easier to work out genetic crossings using maize  
 (ii) Count separately the yellow and purple grains and therefore find the ratios of purple grains to yellow grains
- (b) Using appropriate symbol, work out a genetic cross for F<sub>2</sub> generation  
 (c) From the above information, give the dominant gene  
 (d) State **two** practical applications of genetics in identity determination

33. The figure below is a pedigree chart showing incidence of albinism which is transmitted through a recessive gene-a. Study and answer questions that follow;

- (a) Write down the genotype of persons 1 and 2. Give a reason for your answer  
 (b) Giving your reason state the most likely genotype of person 3  
 (c) The cross between person 15 and 16 represents mating between first cousins.

Comment

why it is not advisable for close relatives to marry

- (d) Apart from albinism name **two** other effects of gene mutation

34. The table below shows results of test to determine blood groups of persons Y and Z.A

tick (✓)

Represents, agglutination while a cross (x) represents no agglutination;

Person	Test with antibody (a)	Test with antibody (b)	Test with Rhesus antibody	Blood group
Y- (male)	✓	X	✓	

X- (female)	X	√	X	
-------------	---	---	---	--

- (a) Fill the blank space in table to show the blood group of the persons **Y** and **Z**
- (b) In order to investigate the inheritance of Rhesus factor, work out a cross between a male with  $Rh^+$  and female with  $Rh^-$ . Let **D** represent the presence of Rhesus factor and **d** to represent the absence of the Rhesus factor
- (c) Determine the genotype of the cross in (b) above.
- (d) Which of the children can donate blood to their mother?
35. Describe the behavioural adaptations of animals to temperature
36. In man blood group inheritance is controlled by multiple alleles in which allele **A** is co dominant to allele **B**. a woman heterozygous for blood group **A** married a man heterozygous for blood group **B**
- State the genotype of both parents
  - Using a pun net square, show the genotypes of  $F_1$  generation
  - State **one** application of knowledge of blood group inheritance in man
  - The nitrogenous bases in nucleic acids are Adenine (A), cytosine(C), Guanine (G), Thiamine (T) and uracil (U). Input of a molecule of DNA the sequence of bases is CTT.
- Using the letters **A, C, G, T, U** where appropriate, write down the base sequence in;
- Corresponding part of the complementary strand of DNA molecules
  - Corresponding part in mRNA
  - A change in the DNA molecules caused the base sequence in the triplets to change from CTT to CAT. State **one** factor which could have caused the change
37. In an investigation plants with red flowers were crossed with plants with white flowers. All the plants in the  $F_1$  generation had pink flowers when the  $F_1$  plants were crossed, he counted 480 plants in  $F_2$  generation
- Using appropriate letter symbols, work out the cross between the  $F_1$  plants to get the  $F_2$  generation
  - Give the phenotypic and genotypic ratios for the  $F_2$  generation  
Phenotypic ratio  
Genotypic ratio
  - How many plants in the  $F_2$  generation had pink flowers? (show your work)
38. In an experiment, a black mouse was mated with a brown mouse. All the off springs in  $F_1$  generation were black. The off springs grew and were allowed to mate with one another. The total

number of F<sub>2</sub> generation offspring were 96.

(a) Using letter **B** to denote the gene for black colour. Work out the genotype of the F<sub>1</sub> generation.

(Use a punnet square)

(b) State the following for the F<sub>2</sub> generation

(i) Genotypic ratio

(ii) Phenotypic ratio

(iii) The total number of brown mice

39. (a) Distinguish between Homologous structures and analogous structures. Give an example

in each case.

Homologous structures

Example

Analogous structures

Example

(b) Explain why parasites develop resistance to certain drugs after a long time of exposure.

(c) (i) What is non— disjunction?

(ii) Give **one** example of a genetic disorder associated with non-disjunction

### 13. Evolution

1. a) Distinguish between homologous and analogous structures in evolution.

b) Name **one** vestigial structure in mammals.

2. a) Give **two** examples of adaptive radiation in animals.

b) State **two** disadvantages of using fossils as evidence of evolution

3. Distinguish between camouflage and mimicry.

4. State the role of light in photosynthesis

5. (a) Name the region of the **gut** where digestion of cellulose takes place.

(b) State role of **cardiac sphincter** in the stomach.

6. (a) Give **two** limitations of fossil records as evidence of evolution

(b) State any **two** similarities in structure between **Homo erectus** and **Homo Sapiens**

7. (a) (i) What is meant by vestigial structures?

(ii) Give an example of a vestigial structure in human

8. Distinguish between the struggle for existence and survival for the fittest as used in the theory of

natural selection

9. Give **two** factors that determine water reabsorption in the distal convoluted tubule

10. Distinguish divergent and convergent evolution

11. (a) What are the advantages of natural selection

(b) All insects are believed to have arisen from a common ancestor. However, modern insects

differ widely in a variety of ways such as in the adaptation of their mouthparts for different

modes of feeding. What kind of evolution is this?

12. Explain why Lamarck's theory of evolution is not accepted by Biologists today.
13. a) i) What is meant by vestigial structures  
ii) Give an example of vestigial structure in human  
b) Explain why certain drugs become ineffective in curing a disease after many years of use
14. (a) What is organic evolution?  
(b) Briefly explain the term "**survival for the fittest**" as used in Darwin's theory of natural selection
15. Explain why insecticides become ineffective against insects if used for several years in succession
16. State **three** limitations of fossils records as an evidence of organic evolution
17. State **three** pieces of evidence that support the theory of organic evolution
18. What is meant by natural selection?
19. (a) Explain why Lamarck's theory of evolution is not accepted today  
(b) State **two** limitations of fossils records as evidence of organic evolution
20. In a breeding experiment, plants with red flowers were crossed. They produced 123 plants with red flowers and 41 with white flowers:
  - (a) Identify the recessive trait
  - (b) Give a reason for your answer
  - (c) If white flowered plants were selfed, what would be the genotype of their offspring? Show your working using appropriate symbols (**R**, **r**)
  - (d) What is a test cross?
21. a) What is organic evolution?  
b) Describe the various evidences which support the theory of organic evolution.
22. (a) What is meant by the term natural selection  
(b) Describe how natural selection brings about the adaptations of a species to its environment  
(c) Distinguish between convergent and divergent evolution  
(d) Discuss **four** evidences to show that evolution has taken place
23. Explain the various evidence for organic evolution
24. (a) What is organic evolution  
(b) Explain why resistance to antibiotics is considered as an example of evolution  
(c) List and explain various evidences of organic evolution
25. Pure breed red flowered plants were cross pollinated with pure breed white flowered plants.

The resulting  $F_1$  offspring's had pink flowers.

  - (a) Using letter **R** to represent the gene for red colour and letter **W** to represent gene for white colour of flowers. Work out the genotype of the  $F_1$  generation
  - (b) If seeds from the  $F_1$  generation plants were planted and allowed to self pollinate. Work out the phenotypic ratio of the  $F_2$  generation

#### 14. Irritability and sensitivity in (a) plants (b) animals

For More Resources Call 0705525657

1. Give **two** functions of the exoskeleton in arthropods.
2. When shoots of young plants are exposed to unidirectional light they bend towards light;
  - a) Name the type of response exhibited by the young shoots
  - b) Explain the cause of the observation above
3. Study the drawing below and use it to answer the questions that follow :-

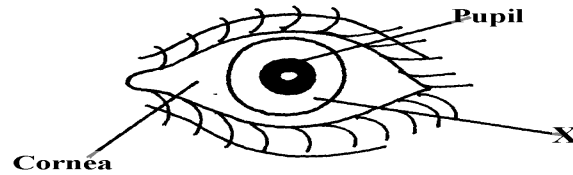

- a) Name the part labeled **X**.
  - b) Describe the changes that occur in the structure **X** in dim light.
  - c) What is meant by the term **accommodation** with reference to the eye?
4. (a) State **two** differences between taxes and tropisms  
(b) Give **two** survival values of tactic movements to organisms
  5. The diagram below represents a type of neurone.

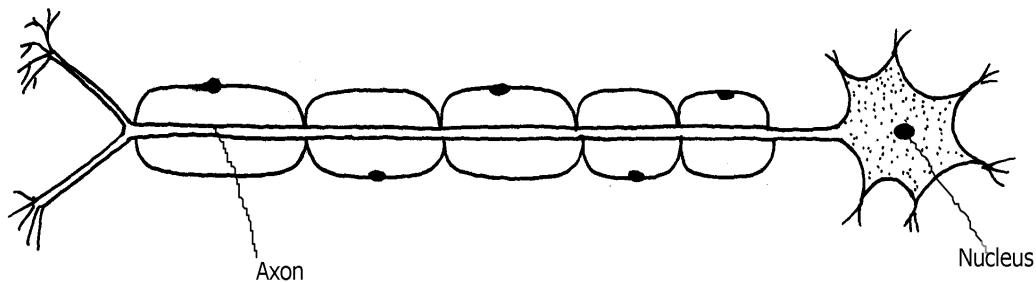

- (a) (i) identify the neuron above.  
(ii) Give a reason for your answer in a (i) above.
  - (b) With an arrow, indicate on the diagram the direction of an impulse through the neurone.
  - (c) Name the chemical substance that brings about transmission of impulse across a synapse
6. A student was traveling from Nairobi to Mombasa. As the bus descended down hill he felt an unpleasant sensation in the ear.
    - (a) How did the sensation come about? \*
    - (b) How can the unpleasant sensation be relieved?

7. An experiment was carried out to investigate a growth response in maize seedling as shown

in the diagram below:

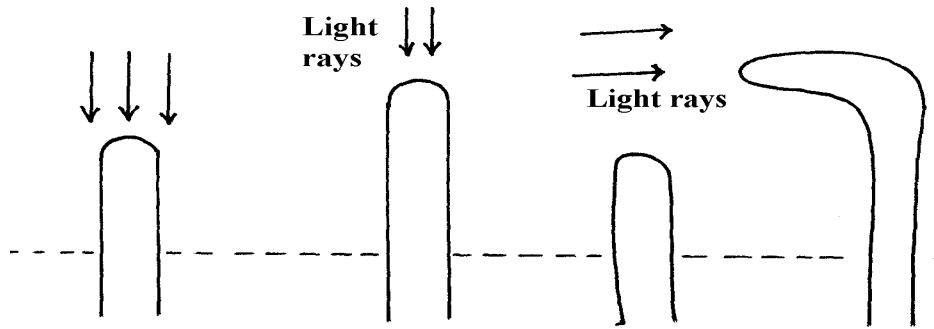

- (a) State the type of response that is being investigated  
.....  
(b) Explain the response exhibited by the shoot
8. State **three** genetic disorders caused by gene mutations
9. The diagram below shows the position of an image formed in a defective eye:-

- (a) Name the defect  
(b) Explain how the defect named in (a) above can be corrected
10. (a) State **three** structural differences between arteries and veins in mammals  
(b) Name a disease that causes thickening and hardening of arteries
11. (a) Name the part of the eye in which the light sensitive cells are located  
(b) List the **two** types of sensory cells found in the part named in (a) above
12. The diagram below illustrates a certain eye defect

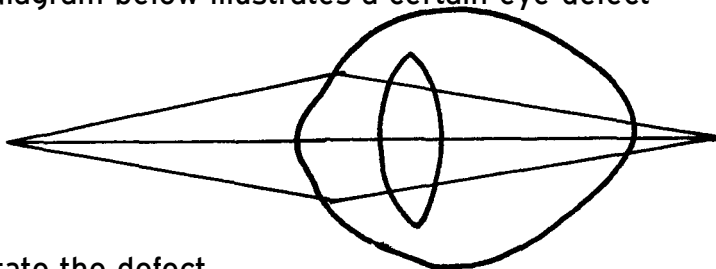

- (a) State the defect  
(b) On the diagram illustrate how the defect can be corrected  
(c) State **one** advantage of having two eyes in human beings
13. Briefly explain the role of the following part of skin
- a) Cornified layer  
b) Malpighian layer
14. State the functions of the following structures of the mammalian ear
- a) Eustachian tube  
b) Essicles
15. a) Distinguish between conditioned and simple reflexes  
b) State how the nerve cell structure is suited to its function of impulse transmission
16. (a) Name the part of the mammalian eye that:
- (i) Transmits impulses to the brain  
(ii) Regulates the amount of light entering the eye



(b) State the changes that occur in the part of the eye named in (a) (ii) above when one moved

from bright light to dim light conditions

16. Name the type of response exhibited by the following:

- (a) A pollen tube growing towards the embryo sac
- (b) Maggots moving from lit side of a box to the dark side

17. A response exhibited by a certain plant tendril is illustrated below:

- (i) Name the type of response
- (ii) Explain how the response named in (i) above occurs

18. A response exhibited by a certain plant tendril is illustrated below:-

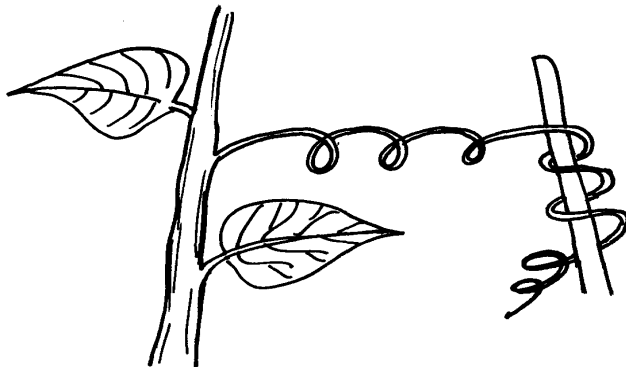

Name the type of response

19. Removal of the apical bud from a shrub is a practice that results in the development of many

lateral buds which later form branches

(a) Give reasons for the development of lateral branches after the removal of the apical bud

(b) Suggest **one** application of this practice?

20. In an accident a victim suffered brain injury. Consequently he had loss of memory which

part of the brain was damaged?

21. A person was able to read a book clearly at arm's length but not at normal reading distance (a) State the eye defect the person suffered from

(b) Why was he unable to read the book clearly at normal distance?

(c) How can the defect be corrected?

22. The diagram below represents a simple reflex arc;

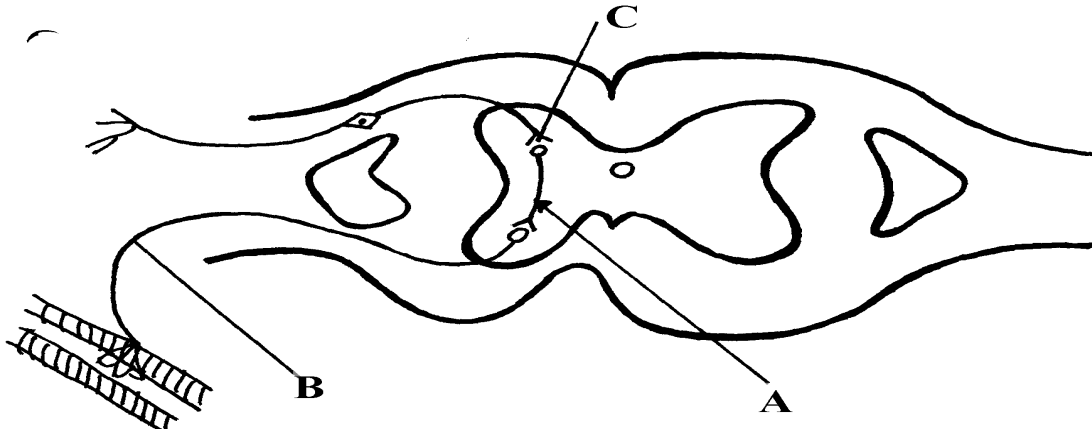

- (a) Name the parts labeled **A** and **B**  
 (b) Explain how an impulse is transmitted across the gap labeled **C**
23. (a) State **two** functions of a mammalian ear  
 (b) How is the cochlea suited to its function
24. State **one** function of potassium ions in the human body.
25. State **two** functions of vitamin B<sub>5</sub> (pantothenic acid).
26. (a) What is the biological importance of tactic responses?  
 (b) A person had an accident and had problems with his vision, hearing and memory.

Identify the part of the brain that was affected

27. Identify the following responses shown by plants:- (a) Shoots grow towards light  
 (b) Roots grow towards gravity  
 (c) Tendril intertwine around an object
28. Name the type of responses exhibited by:-  
 (a) (i) Marine crabs burrowing into the sand to avoid dilution of their body fluids  
 (ii) Chlamydomonas plant moving towards a region of high light intensity  
 (b) (i) What type of neuron is drawn above?  
 (ii) Using an arrow, show the direction of the nerve impulse  
 (iii) Name the part labelled **X**  
 (iv) State the function of part labelled **Y**

(c) Give **two** differences between reflex action and conditioned reflex action

29. In an experiment to investigate the effect of heat on germination of seeds, 12 bags each

Containing 60 pea seeds were placed in a water bath maintained at 85°C .

After every two minutes a bag was removed and seeds contained in it planted. The number that germinated was recorded. The procedure used for pea seeds was repeated for wattle seeds. The

results were as shown in the table below:-

Time (min)	Number of seeds that germinated	
	Pea seeds	Wattle seed
0	60	0

2	60	0
4	48	0
6	42	2
8	34	28
10	10	36
12	2	40
14	0	44
16	0	46
18	0	48
20	0	49
22	0	47

(a) Using a suitable scale and same axes, draw graphs of number of seeds that germinated against

time in hot water for each plant

(b) (i) At what time would number of seeds that germinated for each plant be same?

(ii) How many wattle seeds would have germinated if the 13<sup>th</sup> bag was available and was

removed and seeds contained in it planted at 24minutes?

(c) Explain why the ability of pea seeds that germinated declined with time of exposure to heat

(d) Explain why the ability of the wattle seeds to germinate improved with time of exposure

to heat

(e) Account for the shape of the graph for the wattle seeds which germinated between 20-24

minutes

(f) Some of the pea seeds were allowed to germinate and placed in a large air tight flask

and left for four days:-

(i) Suggest the expected changes in the composition of gases in the flask on the fifth day

(ii) Give reasons for your answer in (f)(i) above

(g) Name **three** factors other than those investigated in (a) above which would affect dormancy

30. How is the mammalian skin adapted to its functions?

31. Explain how the mammalian skin is adapted to it's functions

32. Explain the structure and functions of the human eye.

33. The diagram below shows the position of an image in a defective eye.

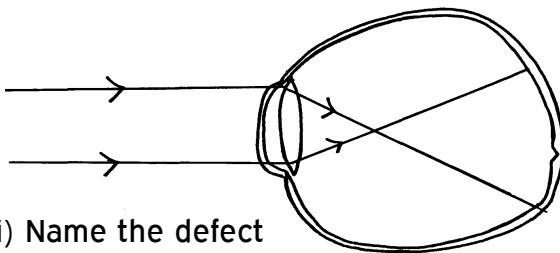

(a) (i) Name the defect

(ii) State the causes of the defect

(b) Explain how the defect in a(i) above can be corrected.

(c) State the functions of cones

(d) How are nocturnal animals adapted to seeing?

## 5. Support and movement in (a) Plants (b) animals

1. Explain how the following tissues are adapted to provide mechanical support in plants:  
-
  - a) Parenchyma
  - b) Collenchyma
  - c) Sclerenchyma
2. The diagram below represents a bone in the mammalian skeleton

- a) Identify the bone with a reason
  - b) State the function of the part labeled **D**
3. The diagram below represents a mammalian bone

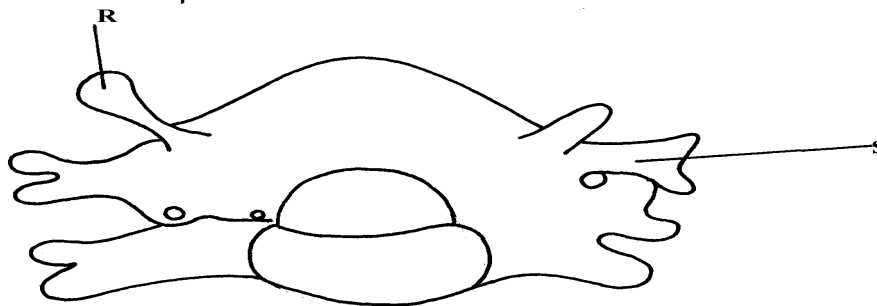

- (a) Identify the bone shown above
  - (b) State the function of the parts labelled **R** and **S**
  - (c) State the region of the body in which the bone is found
4. (i) Name **two** bones that form the ball and socket joint in the fore limb of a mammal
  - (ii) Name the fluid that is found in the above mentioned joint and its function
  5. State **three** types of skeleton found in Kingdom animalia
  6. State **three** differences between an animal's muscle cell and plant's palisade cell
  7. The diagram below represents a mammalian bone

- (a) Name the bone
  - (b) (i) Which bone articulates with the bone shown in the diagram at the notch
  - (ii) Name the type of joint formed when the bones in **b(i)** articulate
8. (a) Name the hard outer covering of the members of the phylum Arthropoda
  - (b) State **two** roles played by the structure named in (a) above
  9. (a) State the role of lignin in the wall of the xylem vessel
  - (b) How do vascular bundles contribute to support in plants
  10. (a) Distinguish between tendons and ligaments
  - (b) State **one** way through which herbaceous plants achieve support

11. Name the ;
- a) i) Material used to strengthen the xylem tissue
  - ii) Tissue that is removed when the bark of a dicotyledonous plant is ringed
- b) State the areas of the plant where translocated materials are taken
12. Give **three** importance of mammalian skeleton
13. The diagram below represents the anterior view of a rib

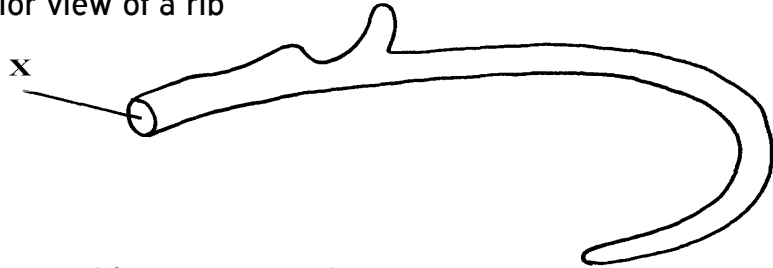

Name the part labelled X

14. The diagram below represents a bone obtained from a mammal
- a) Name the bone
  - b) Name the:
    - i) Bones which articulate with the bone named in (a) above at the cavity labelled K
    - ii) Joint formed by the two bones at K
  - c) State functions of part labelled J

15. The diagram below represents a bone obtained from a mammalian skeleton:

- (a) Identify the bone
- (b) Name the:
  - (i) Bone it articulates with at point A
  - (ii) Type of joint that forms at point B in articulation with other bones

16. The diagram below represents a bone obtained from a mammal

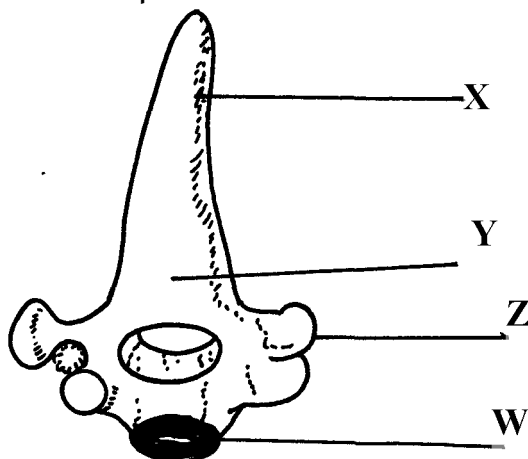

- (a) Identify the bone
- (b) Name the structures labeled **X** and **W**
- (c) Name the bone that articulate with structure labeled **Z**

17. (a) Name the vertebra in a mammalian body that is characterised by presence of **odontoid process**.

(b) State the function of the **odontoid process**

- 18. a) Name **three** supporting tissues in plants
- b) Study the diagram below and answer the questions which follow:

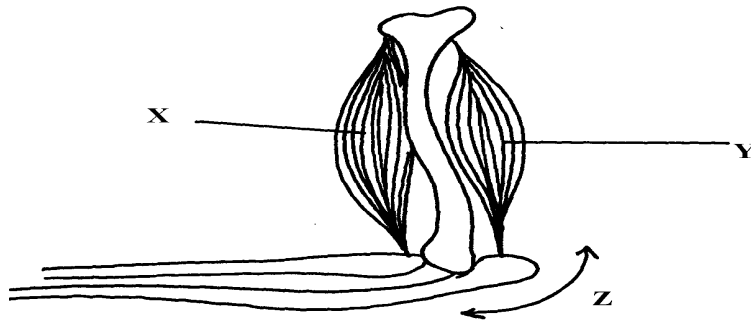

- i) Identify the muscle represented by **X** and **Y**
- ii) Describe how muscles **x** and **y** cause straightening of the joint **z**
- c) Name the joint **z**

- 19. (a) What is the importance of locomotion in animals?
- (b) Explain how a bony fish is adapted for movement in its habitat

## 16. Human health

- 1. a) Name the causative agent of cholera.
- b) Name the intermediate hosts in the life cycle of the following parasites;
  - i) *Ascaris lumbricoides*.
  - ii) *Schistosoma haematobium*.
- c) How does the parasite *plasmodium vivax* gain entry into its host?
- 2. The graph below shows body temperature of a patient suffering from malaria

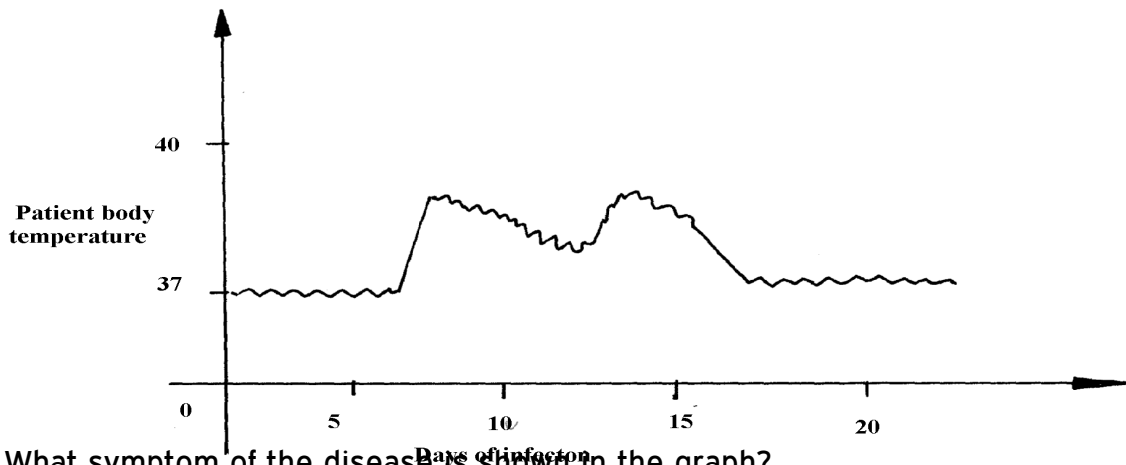

- (a) What symptom of the disease is shown in the graph?
- (b) Name the organism that causes malaria
- (c) Suggest **one** method of controlling spread of malaria

3. Name the causative agent of typhoid
4. Malaria is a common disease in Kenya:-
  - (a) What causes the disease?
  - (b) State **one** control measure of the disease
5. a) Name the causative agents of the following disease in humans:-
  - i) **Typhoid**;
  - ii) **Amoebic dysentery**;
  - b) Name the disease in human caused by plasmodium falciparum
6. Below are diagrams of disease causing micro-organisms. Use them to answer the questions that follow:

- (a) State the kingdom to which they are found.
  - (b) Name the diseases caused by the organisms: A and B
  - (c) State **one** way in which the disease named for organism B can be prevented
7. Explain why it is important to go for voluntary counseling and testing (VCT) on HIV/AIDS
8. Name **one** human disease caused by each of the following parasites.
  - (a) Plasmodium falciparum.....
  - (b) Entamoeba histolytica .....

**FOR MARKING SCHEMES  
CALL 0705525657**