

BIOLOGY NOTES

F1 SIMPLIFIED TUTORIAL

***Well organized detailed simplified
Biology learning notes***

**A PRODUCT OF MWALIMU
PUBLISHERS**

CALL/TEXT/WHATSAPP

0707550000 / 0705525657

FOR MORE ELEARNING RESOURCES

INTRODUCTION TO BIOLOGY

- Biology is the branch of science that deals with the study of living things. In Greek, Bios means life while Logos means knowledge.

Branches of biology

There are two main branches:

1. **Botany:** Study of plants
2. **Zoology:** Study of animals

The others include:

1. **Ecology:** Study of living things in their surroundings.
2. **Genetics:** The study of inheritance and variation.
3. **Entomology:** Study of insects
4. **Parasitology:** Study of parasites
5. **Taxonomy:** Study of classification of organisms
6. **Microbiology:** Study of microscopic organisms
7. **Anatomy:** Study of structure of cells
8. **Cytology:** Study of cells
9. **Biochemistry:** Study of chemical changes inside living organisms

Question

Name at least six other smaller branches of biology (6 marks).

Importance of Biology

1. **Solving environmental problems** e.g. Food shortage, poor health services, pollution, misuse of environmental resources etc.
2. **Choice of careers** e.g. Medicine, Agriculture, public health, Veterinary, Animal husbandry, Horticulture, Dentistry etc.
3. **Acquiring scientific skills** e.g. observing, identifying, recording, classification, measuring, analyzing, evaluating etc.
4. **International co-operation** e.g. Development of HIV/AIDS vaccine, fight against severe Acute respiratory Syndrome (SARS), fight to save ozone layer from depletion, management of resources through international depletion.

Others

- Help on study of other subjects
- Learn what living things are made up of and their bodies work
- Acquire knowledge about plant and animal diseases and their treatment.
- Know the effects of our bodies on drug and substance abuse and can kill.

- Learn about HIV/AIDS diseases and other viral diseases e.g. its treatment— balanced diets, proper hygiene, spreading, sexual behavior, cultural practices etc.

Question

List five professional occupations that require the study of biology. (5 marks)

Characteristics of living things;

1. **Nutrition:** Process by which living things acquire and utilize nutrients: plants photosynthesize; animals feed on already manufactured foods.
2. **Respiration:** energy-producing process occurring in all the cells of living things.
3. **Gaseous Exchange:** where living things take in air (oxygen) and give out air (carbon iv oxide) across respiratory surfaces.
4. **Excretion:** Process by which waste or harmful materials resulting from chemical reactions within cells of living things are eliminated. Excess of such materials poison living things.
5. **Growth and Development:** **Growth** –is the irreversible increase in size and Mass.— Essential for body function. **Development** –Irreversible change in complexity of the structure of living things.
6. **Reproduction:** Process by which living things give rise to new individuals of the same kind.
7. **Irritability:** Is the ability of living things to perceive changes in their surroundings and respond to them appropriately. E.g. reaction to changes in temperature, humidity, light, pressure and to the presence of certain chemicals.
8. **Movement:** Change in position by either a part or the whole living thing. Locomotion – Progressive change in position by the whole living thing. In animals, movement include; swimming, walking, running, flying. In plants, closing of leaves, folding of leaves, closing of flowers, growing of shoots towards light etc.

Question

1. List four uses of energy obtained from the process of respiration. (4 marks).
2. List six characteristics of living things (6 marks).

Collection of specimens

Apparatus used

1. **Sweep net:** for catching flying insects.
2. **Fish net:** For trapping small fish and other small water animals.
3. **Pooter:**For sucking small animals from rock surfaces and tree barks.
4. **Bait trap:** For attracting and trapping small animals e.g. rats.
5. **Pit fall trap:** For catching crawling animals.
6. **Pair of forceps:** picking up small crawling animals e.g. stinging insects.
7. **Specimen bottles:** keeping collected specimen. Larger specimens require

large bottles.

8. **The magnifying lens:** Instrument used to enlarge objects. Lenses are found in microscope and the hand lens (magnifier). Its frame is marked e.g. x8 or x10—indicating how much larger will be the image compared to object.

Precautions during Collection and Observation of specimens

- Collect only the number of specimen you need.
- Do not harm the specimens during the capture or collection exercise.
- Handle dangerous or injurious specimens with care e.g. stinging plants or insects i.e. use forceps or hand gloves.
- The teacher will immobilize highly mobile animals. (diethyl ether, formalin, chloroform)
- Do not destroy the natural habitat of the specimens.

Comparison between plants and animals

Plants	Animals
1. Green in colour(have chlorophyll)	1. Lack chlorophyll thus feed on readymade food.
2. Their cells have cellulose cell walls.	2. Cells lack cellulose cell walls.
3. Respond slowly to changes in the environment.	3. Respond quickly.
4. Lack specialized excretory organs.	4. Have complex excretory organs.
5. Do not move about.	5. Move about in search of food and water.
6. Growth occurs in shoot and root tips.(apical growth)	6. Growth occurs in all body parts(intercalary growth).

CLASSIFICATION I

INTRODUCTION

- ✓ Living things are also known as living organisms.
- ✓ Organisms (forms of life) have distinguishing characteristics and therefore are grouped. **The Magnifying lens**
- ✓ -Is used for enlarging small objects.

The magnifying lens

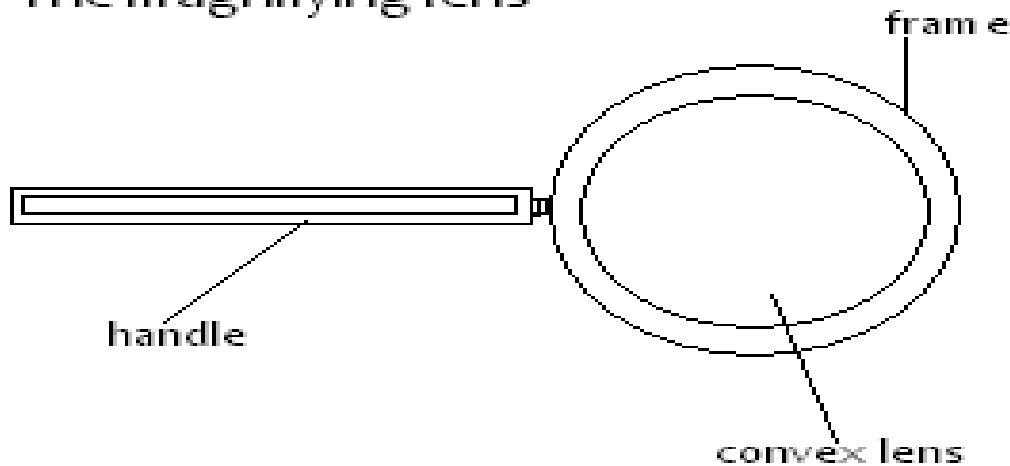

Procedure of its use

place the object on the bench.

- Move the hand lens from the object to the eye.
- An enlarged image is seen.

$$\text{Drawing magnification} = \frac{\text{Length of the drawing/ drawing Length}}{\text{Length of the object/Actual Length}}$$

(Diagram)

EXTERNAL FEATURES OF PLANTS AND ANIMALS

External features of plants

- i) Rhizoids as in moss plant.
- ii) Fronds in ferns.
- iii) Roots, stems, leave, flowers, seeds, fruits, and cones in higher plants.

External features of animals

- i) Tentacles in hydra
- ii) Feathers in birds
- iii) Shells in snails
- iv) Wings in birds

- v) Fur and hair in mammals
- vi) Scales and fins in fish
- vii) Proglotids in tapeworms
- viii) Mammary glands in mammals
- ix) Locomotory Structures e.g. limbs in insects
- x) Body pigmentation

Practical activity 1

To collect and observe animal specimens

To collect and observe plant specimens

What is classification?

-Is an area of biology that deals with the grouping of living organisms according to their structure. Organisms with similar structures are put under one group referred to as a **taxon**—**taxa** (plural).

The groupings also consider evolutionary relationships (phylogeny)—since all living organisms had a common origin at one time.

Taxonomy—Science of classification. Taxonomist—Biologist who studies taxonomy.

Need for classification.

Reasons

1. To identify living organisms into their correct groups for reference and study
2. To bring together living organisms with similar characteristics but separate those with different features.
3. To arrange information of living organisms in an orderly manner. This avoids chaos and confusion.
4. To understand the evolutionary relationship between different organisms

Diversity of Living Organisms

- Organisms with similar characteristics are placed under one group called **taxon (taxa)**.
- The science of classification is known as **taxonomy**.
- Biologists who study taxonomy are called **taxonomists**.

Historical Background of Classification

- Long time ago classification was artificial where living things were classified as either plants or animals.
- Plants were classified as herbs, shrubs and trees.
- Animals were further divided into carnivores, herbivores and omnivores.
- Today modern classification uses evolutionary relationships between living organisms.

Taxonomic Units

Are groups (taxa) into which organisms are placed as a matter of convenience. Groups are based on observable characteristics common in the group.

In a classification scheme (taxonomic units or groups, a hierarchy of groups are recognized starting with the first largest and highest group; the **Kingdom** to the smallest and lowest unit; the **species**.

There are 7 major taxonomic units.

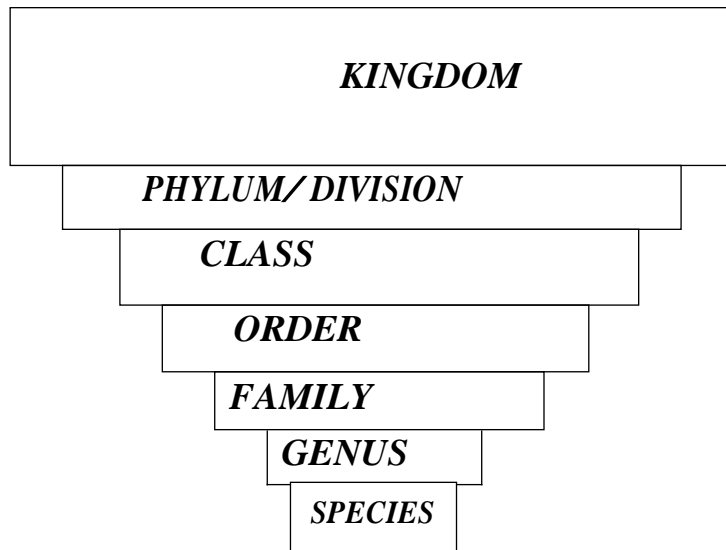

The Kingdom

There are five Kingdoms of living organisms, namely:

1. **Kingdom Monera:** bacteria
2. **Kingdom protocista:** algae, protozoa, amoeba, paramecium
3. **Kingdom Fungi:** Moulds, Yeast, Mushrooms
4. **Kingdom Plantae:** Moss plants, ferns, maize, garden pea, pine, meru oak, bean etc.
5. **Kingdom Animalia:** hydra, tapeworms, bees, human beings etc.

A **kingdom** is divided into **Phyla** in animals or divisions in plants and sorts out organisms based on body plan and form.

Plan is the adaptation to a special way of life.

The **Class** is further divided into small groups; **Orders** using structural features. Orders are divided **into families** using structural features, then Families into **Genera** (singular genus) –based on recent common ancestral features that are less adaptive. Genus is divided into **species** i.e. kind of plant, or animal.

Down the hierarchy, the number of organisms in each group decreases but their similarities increases.

The Species group members naturally interbreed to produce fertile off springs. Minor differences are exhibited in the species groups e.g. on colour of the skin in human beings and varieties of plants.

The groups of the species are termed to as varieties, races or strains.

Classification of A human being and a maize plant

Taxonomic unit	Human being	maize	bean
-----------------------	--------------------	--------------	-------------

kingdom	Animalia	plantae	plantae
Phylum or division	Chordata	Angiospermaphyta	Angiospermae
class	Mammalia	monocotyledonae	Dicotyledonae
order	Primates	Graminales	Rosales
family	Hominidae	Graminaceae	Leguminosae
genus	homo	zea	Phaseolus
species	sapiens	mays	Vulgaris
Scientific name	Homo sapiens	Zea mays	phaseolus vulgaris

Scientific Naming Of Living Organisms

Present naming was developed by carolus Linnaeus 18th c, where organisms were given 2 names in Latin language.

Living organisms have their scientific names and common names i.e. local or vernacular names.

Scientific naming uses the double naming system—**Binomial system**.

In binomial system, an organism is given both the **genus** and **species** name.

Binomial nomenclature (Double–naming system)-Is the assigning of scientific names to living organisms governed by a definite set of rules recognized internationally.

Principles of binomial nomenclature

- a) The first, genus name, should begin with a capital letter and the second name, species, should begin or written in small letters e.g.

Lion-----Panthera leo

Leopard----- Panthera pardus

Domestic dog ----- Canis farmiliaris

Human being -----Homo sapiens

Maize plant---Zea mays

Lion and Leopard are closely related ---Same genus but distantly related—different species.

- b) The scientific names must be printed in italics in textbooks and where hand written to be underlined e.g. Pantheraleo.

- c) The specific name (species) is frequently written with the name of the scientist who first adequately described and named the organism e.g. Phaseolus vulgaris
i.e. Vulgaris is the scientist who described and named the bean plant.

- d) Biologists should give a Latinized name for a newly described animal or plant species where Latin name is missing e.g.

Meladogyne kikuyuensis – Is a scientific name of a nematode from kikuyu.

Aloe kilifiensis --- A member of Aloeceae family from Kilifi discovery. Garinsoga parviflora waweruensis --- a member of Macdonald eye family discovered by Waweru

Study Question 1

Complete the table below

Taxon	Lion	Domestic dog	Gardenpea	Napier grass
kingdom				
Phylum/division				
class				
order				
family				
genus				
species				

Scientific name -----

THE CELL

Introduction

- The cell is the basic unit of an organism.
- All living organisms are made up of cells.
- Some organisms are made up of one cell and others are said to be multicellular.
- Other organisms are made of many cells and are said to be multicellular.
- Cells are too little to see with the naked eye.
- They can only be seen with the aid of a microscope.

The microscope

The microscope is used to magnify objects.

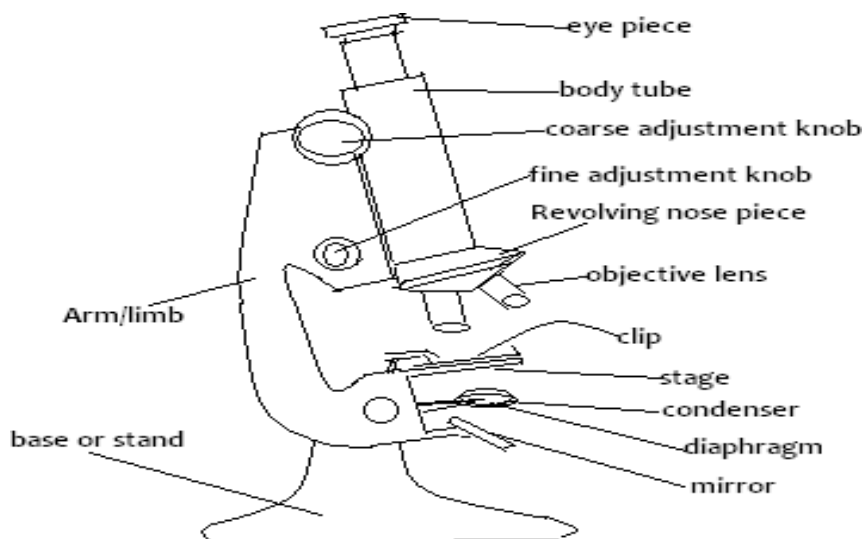

The light microscope

Microscope Parts & Function

1. Eyepiece	Contains a magnifying lens that focuses the image from the objective into your eye.
2. Course Adjust	For focusing under low magnification
3. Fine Adjust	For focusing under high magnification or low

4. Low Power Objective	For large specimens or overview
5. High Power Objective	For detailed viewing or small specimens
6. Specimen on glass slide	What you want to look at
7. Stage	Supports specimen in correct location to lens
8. Condenser	Focuses the light on specimen
9. Diaphragm (iris or disc)	Regulates amount of light and contrast
10. Light Source	Illuminates the specimen for viewing

Handling and Care of the Microscope

The following rule should be observed:

1. Use both hand when carrying the microscope. One hand should hold the base and the other holds the limb.
2. Never place the microscope too close to the edge of the bench.
3. Do not touch the mirror and the lenses with the fingers.
4. Clean dirty lenses using soft tissue.
5. Clean other parts using a soft cloth.
6. Do not wet any part of the microscope.
7. Make sure the low power clicks into position in line with the eye piece before and after use.
8. Always store the microscope in a safe place free from dust and moisture. **Using the**

Microscope

1. Place microscope on the bench with the stage facing away from you.
2. Turn the low power objective lens until it clicks into position.
3. Ensure the diaphragm is fully open.
4. Look through the eyepiece with one eye. Adjust the mirror to ensure maximum light can pass through.
5. Place the slide containing the specimen on the stage and clip it into position. Make sure the slide is at the centre of the field of view.
6. Again look through the eyepiece while adjusting the mirror to ensure maximum light reach the specimen.
7. Use the coarse adjustment knob to bring the low power objective lens to the lowest point. While viewing through the eyepiece, turn the coarse adjustment knob gently until the specimen comes into focus.

8. Use the fine adjustment knob to bring the image into sharp focus.
9. Make a drawing of what you see.
10. For higher magnification, turn the medium power into position and adjust the focus using the coarse knob. Use the fine adjustment knob for sharper focus.
11. For even large magnifications, turn the high power objective lens into position. In this case use only the fine adjustment knob to bring details into sharper focus.

Magnification

- The magnifying power is usually inscribed on the lens.
- To find out how many times a specimen is magnified, the magnifying power of the objective lens is multiplied by that of the eye piece lens.
- If the eye piece magnification lens is x10 and the objective lens is x4, the total magnification is x40.
- Magnification has no units.
- It should always have the multiplication sign.e.g.x40
- Magnification of the object viewed under the microscope is calculated by;
Magnification = Eye Piece Lens Magnification X Objective Lens Magnification.
- If the eyepiece lens has the magnification of x5 and the low power objective lens has a magnification of x10, the total magnification is $5 \times 10 = 50$.

Study Question 1

Fill the table below.

Eye piece lens magnification	Objective lens magnification	Total magnification
X5	X4	
X10	X5	
X10		X100
	X40	X600
X10	X100	

Practical Activity 1

Cell Structures as Seen Under the Light Microscope

- The following cell organelles can be seen under the light microscope.
 - Cell wall.
 - Cell membrane
 - Cytoplasm
 - Nucleus
 - Vacuole.
 - Chloroplasts.

Cell Structure as Seen Through the Light Microscope

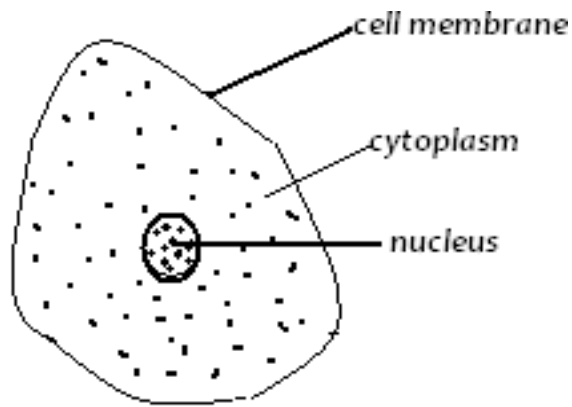

A typical animal cell

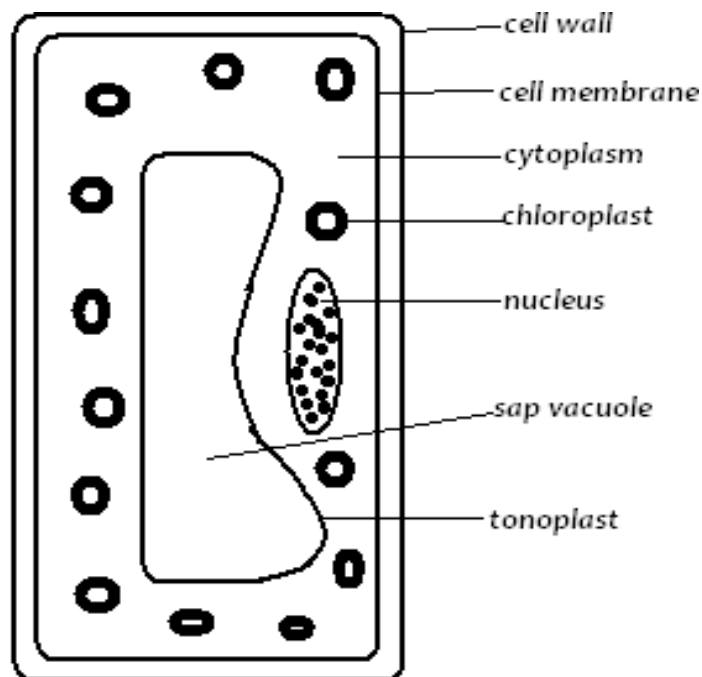

Generalised plant cell

The Electron Microscope.

- It is more powerful than the light microscope.
- It can magnify up to 500,000 times and has high resolving power.
- The high resolving power of the electron microscope enables it to separate objects which lie close to one another.
- Electron microscope uses a beam of electrons instead of light to illuminate the object.

Cell Structures as Seen Under the Electron Microscope

A generalised animal cell as seen under Electron microscope

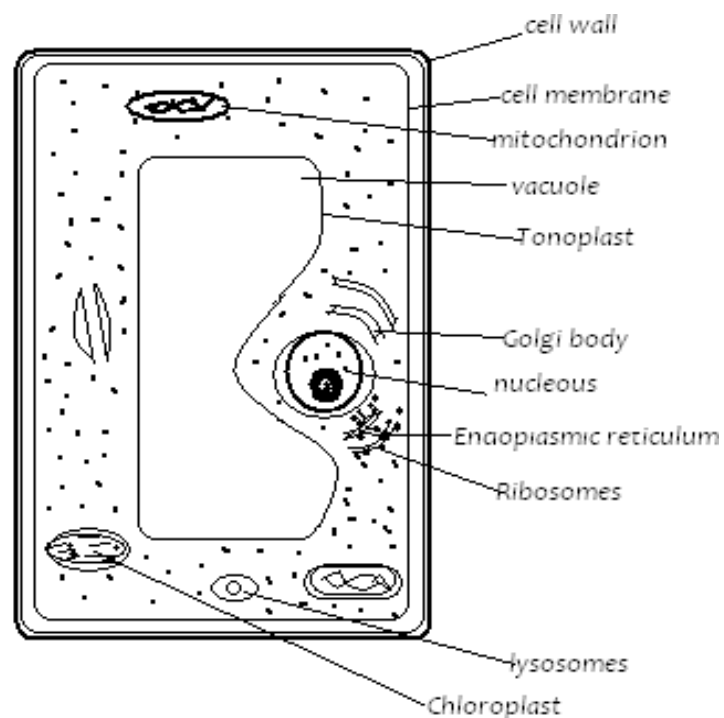
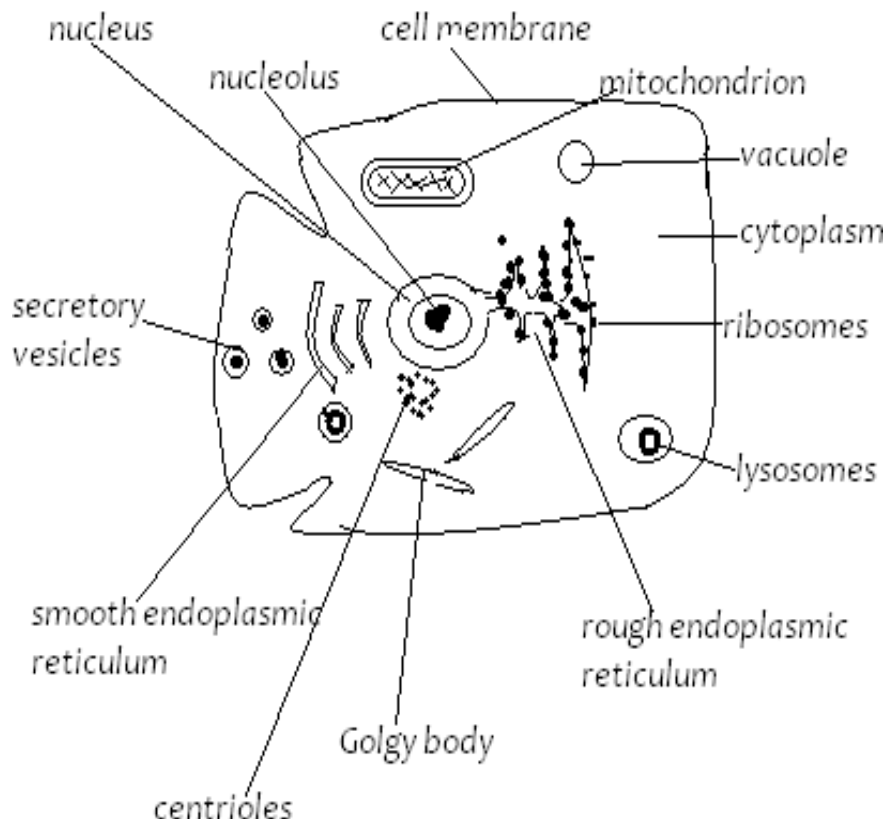

A generalised plant cell as seen under the electron microscope

The Cell Organelles

i) Cell membrane (Plasma Membrane).

- It has three layers i.e. one layer of phospho-lipid layer sandwiched between two protein layers.
- It is flexible with pores and has the following main functions.
 - a) Encloses all the cell contents.
 - b) It allows selective movement of substances into and out of the cell since it is semi-permeable.

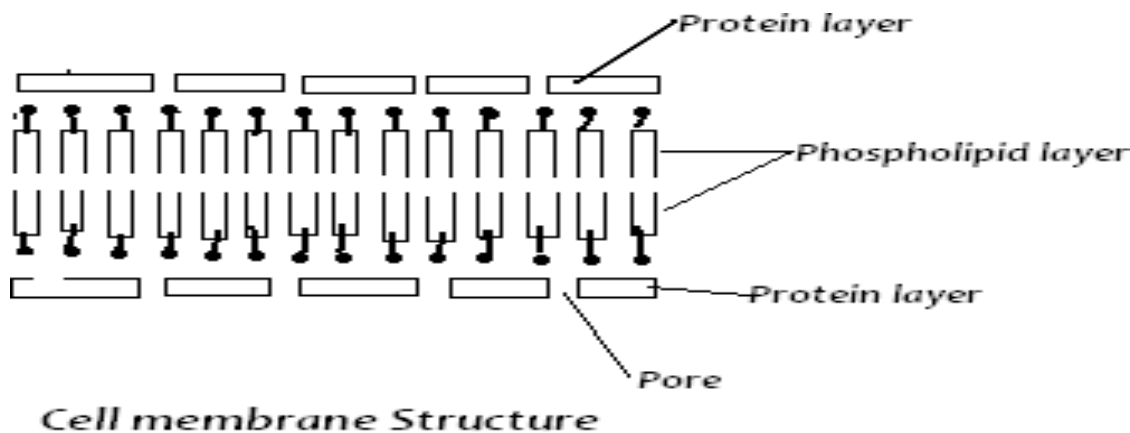

ii) Cytoplasm

- It is a fluid medium in which chemical reactions take place.
- It has some movement called cytoplasmic streaming.
- It contains organelles, starch, glycogen, fat droplets and other dissolved substances.

iii) Nucleus

- It has a double membrane called the nuclear membrane.
- The membrane has pores allowing passage of materials into and out of the cell.
- Nucleus has a fluid called **nucleoplasm** in which the **nucleolus and chromatin** are suspended.
- Nucleolus manufactures **ribosomes** while chromatin contains the hereditary material.

iv) Mitochondria(Mitochondrion)

- They are sausage shaped and are the **respiratory sites**.
- Mitochondrion has two membranes. Inner membrane is greatly folded into **cristae** to increase the surface area for respiration.
- Cells that require a lot of energy have a large number of mitochondria e.g. muscle cell, sperm cell, kidney cell etc.

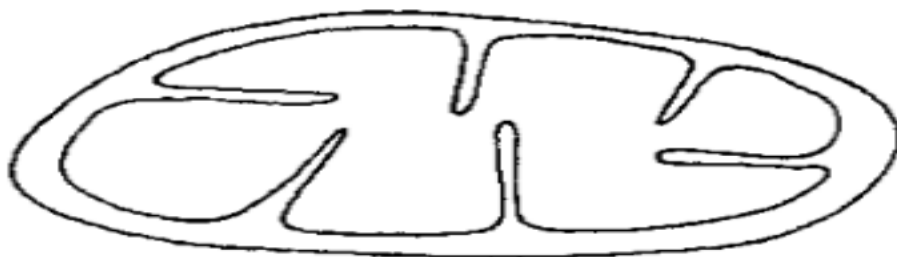

v) Endoplasmic Reticulum (ER)

- Some endoplasmic reticulum have granules called **Ribosomes** on their surfaces hence referred to as **rough endoplasmic reticulum**.
- Others do not contain ribosomes hence the name **smooth endoplasmic reticulum**.
- Rough endoplasmic reticulum **transport proteins** while the smooth endoplasmic reticulum **transports lipids**.

vi) **Ribosomes**

- These are small spherical structures attached to the ER.
- They consist of protein and ribonucleic acid (RNA).
- They act as sites for the synthesis of proteins.

vii) **Lysosomes**

- They contain **lytic enzymes** which break down large molecules, destroy worn out organelles or even the entire cell.

viii) **Golgi Bodies (Golgi apparatus)**

- Their function is to package and transport **glyco-proteins**.
- They are also associated with **secretion** of synthesized **proteins** and **carbohydrates**.

ix) **Centrioles**

- They are rod shaped structures that are used in **cell division** and in the formation of **cilia and flagella**.
- Plant cells lack the Centrioles.

x) **Chloroplasts**

- They are egg shaped and contain two membranes.
- Chloroplast has chlorophyll which traps light energy to be used during photosynthesis.

xi) **Vacuoles**

- These are sacs filled with a fluid called cell sap.
- Animal cells contain small vacuoles while plant cells have large vacuoles.
- Sap vacuoles store sugars and salts.
- Food vacuoles store and digest food while contractile vacuoles excrete unwanted materials from the cell.

xii) **Cell wall**

- It is a rigid outer cover of the plant cells made of **cellulose**.
- It gives the plant cell a **definite shape** while providing **mechanical support** and **protection**.
- Cell wall also allows water, gases and other materials to pass through it.

Study Question 3

Differences between Plant and Animal Cells

Practical Activity 3

Preparation and Observation of Temporary Slides of Plant Cells

- A piece of epidermis is made from the fleshy leaf of an onion bulb. It is placed on a microscope slide and a drop of water added.
- A drop of iodine is added and a cover slip placed on top.
- Observations are made, under low and medium power objective.
- The cell wall and nucleus stain darker than other parts.
- A labelled drawing is made.
- The following are noted: **Nucleus, cell wall, cytoplasm and cell membrane.**

Observation of permanent slides of animal cells

- Permanent slides of animal cells are obtained e.g, of cheek cells, nerve cells and muscle cells.
- The slide is mounted on the microscope and observations made under low power and medium power objectives.
- Labelled drawings of the cells are made.
- A comparison between plant and animal cell is made.

Observation and Estimation of Cell Size and Calculation of Procedure

- Click to low power

- place transparent ruler with its millimeter marks on the stage
- focus so that the millimeter marks can be seen as thick dark lines
- estimate the diameter of field of view by counting the one millimeter spaces between the first mark and the last one across the field of view as shown below

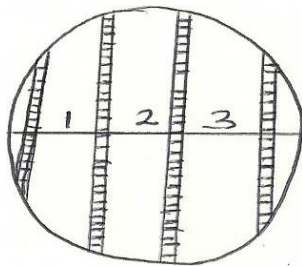

- the diameter of the field of view above is estimated as 3.2 mm
- convert the diameter of the field of view from millimeters to micrometers i.e. $3.2/1000$
- Estimate the fraction of the field of view occupied by the cell. This is done by estimating the number of cells placed end to end that would fill the diameter of the field of view as shown below

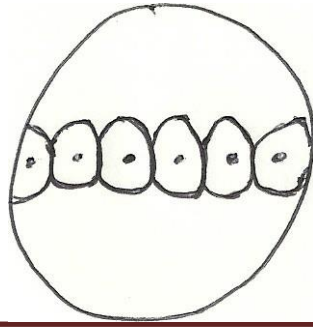

- in the figure above, it is estimated that approximately six cells will occupy the diameter of the field of view
- therefore, one cell will occupy $\frac{1}{6}$ of the field of view
- its diameter is calculated as $\frac{1}{6}$ times the diameter of the field of view

i) **In a drawing of a giraffe**, the height of the head from the ground was recorded as 10cm. the drawing also showed a magnification of 0.02. calculate the actual height of the giraffe

Drawing height = 10cm = 500cm

Magnification 0.02

QUESTION

- i) In a class experiment to estimate sizes of cells a student observed and obtained millimeter marks on the field of view of a microscope as shown in the diagram below.

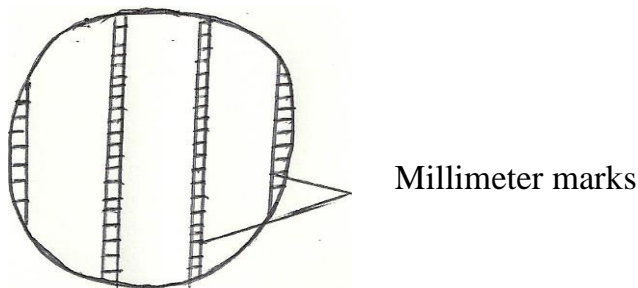

- If the student counted 40 cells on the diameter of the field of view, what was the approximate size of the each cell in micrometers?

Diameter of field of view = $3 \times 1000 = 75 \mu\text{m}$

Number of cells

CELL PHYSIOLOGY

- This is the study of the functions of cell structures.

Membrane Structure and Properties

- A membrane is a surface structure which encloses the cell and organelles. Membranes regulate the flow of materials into out of the cell or organelle.
- Examples of membranes: cell membrane, tonoplast (membrane surrounding the vacuole), nuclear membrane, mitochondrial membrane, chloroplast membrane etc.

The Cell Membrane

- It has three layers, two protein layers and a phospholipid layer sandwiched in between the two.

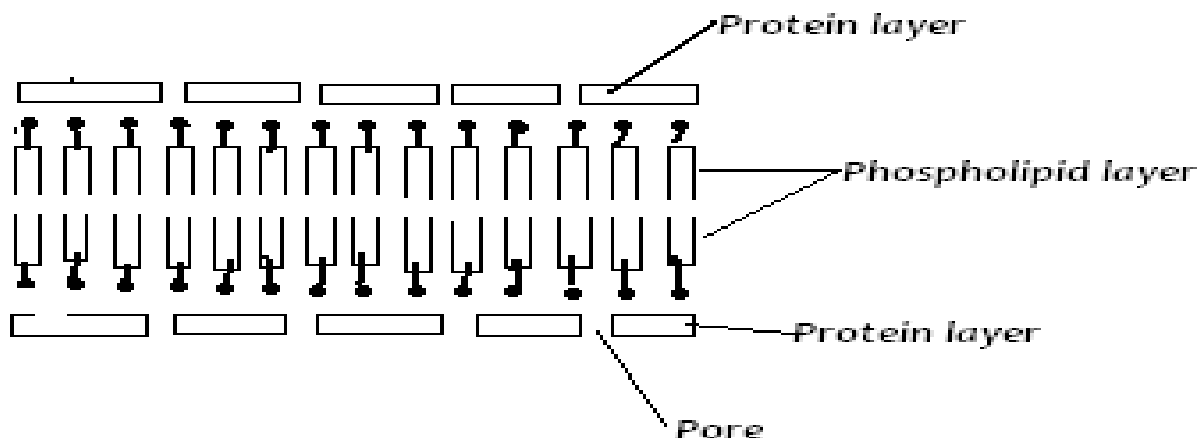

Cell membrane Structure

Properties of Cell Membrane

1. **Semi-permeability.** – It has small pores allowing for the passage of molecules of small size into and out of the cell. Cell Wall however allows all materials to pass through it hence it is referred to as being Permeable.
2. **Sensitivity to Changes in Temperature and pH** – Extreme temperature and pH affects the cell membrane since it has some protein layers. Such changes alter the structure of the membrane affecting its normal functioning.
3. **Possession of Electric Charges** – it has both the negative and positive charges helping the cell to detect changes in the environment. These charges also affect the manner in which substances move in and out of the cell

mwalimupublishers@gmail.com
PHYSIOLOGICAL PROCESSES

- The ability of the cell to control the movement of substances in and out of the cell is achieved through physiological processes such as **Diffusion, Osmosis and Active Transport**.

Diffusion

- This is a process by which particles move from a region of **high concentration** to a region of **low concentration**.

Practical Activity 1

To demonstrate diffusion using potassium permanganate (VII)

- The difference in concentration of particles between the region of high concentration and the region of low concentration is known as the **diffusion gradient**.

Role of Diffusion in Living Organisms

1. Absorption of Materials

- Mineral salts in the soil enter the root by diffusion since their concentration in the soil is greater than in the root hair cells.
- Digested food (glucose and amino acids) diffuse across the wall of the ileum into the blood for transport to rest of the body.

2. Gaseous Exchange in Plants and Animals

- In both plants and animals, respiratory gases (oxygen and Carbon (IV) oxide) are exchanged through simple diffusion depending on their concentration gradient.

3. Excretion of Nitrogenous Wastes

4. Transport of Manufactured Food form Leaves to other Plant Parts.

Factors Affecting Diffusion

a) Diffusion Gradient

- A greater diffusion gradient between two points increases the rate of diffusion.

b) Surface Area to Volume Ratio

- The higher the ratio the greater the rate of diffusion and the lower the ratio the lower the rate.
- This means that small organisms expose a large surface area to the surrounding compared to large organisms.
- Small organisms therefore depend on diffusion as a means of transport of foods, respiratory gases and waste products.

c) Thickness of Membranes and Tissues

- The thicker the membrane the lower the rate of diffusion because the distance covered by the diffusing molecules is greater. The thinner the membrane, the faster the rate.

d) Size of the Molecules

- Small and light molecules diffuse faster than large and heavy molecules.

e) Temperature

- Increase in temperature increases the energy content in molecules causing them to move faster.

Osmosis

- This is the process where **solvent molecules (water)** move from a **lowly concentrated solution** (dilute) to a highly **concentrated solution** across a **semi-permeable membrane**.

Diagram fig 4.6

- The highly concentrated solution is known as **Hypertonic Solution**.
- The lowly concentrated solution is called **Hypotonic solution**.
- Solution of the same concentration are said to be **Isotonic**.
- Osmosis is a special type of diffusion because it involves the movement of solvent (water) molecules from their region of high concentration to region of low concentration across a semi permeable membrane.

Osmotic Pressure

- This is the pressure which needs to be applied to a solution to prevent the inward flow of water across a semi permeable membrane. This is the pressure needed to nullify osmosis.
- Osmotic pressure is measured using the **osmometer**.

Osmotic Potential

- This is the measure of the pressure a solution would develop to withdraw water molecules from pure water when separated by a semi permeable membrane.

Water Relations in Animals

- Cell membrane of the animal cell is semi permeable just like the dialysis/visking tubing.
- Cytoplasm contains dissolved sugars and salts in solution form.
- If an animal cell e.g. a red blood cell is placed in distilled water (hypotonic solution), water flows in by osmosis.
- The cell would swell up and eventually burst because the cell membrane is weak. The bursting of the red blood cell when placed in hypotonic solution is called **Haemolysis**.
- If a similar red blood cell is placed in a hypertonic solution, water is drawn out of the cell by osmosis. The cell will shrink by a process called **Crenation**.
- Body fluids surrounding the cells must therefore have same concentration as to that which is found inside the cell.

Diagrams

Water Relations in Plants

- When a plant cell is placed in a hypotonic solution it gains water by osmosis and distends outwards.
- As the cell gains more water, its vacuole enlarges and exerts an outward pressure called **turgor pressure**. As more water is drawn in, the cell becomes firm and rigid and is said to be **turgid**.
- The cell wall in plant cell is rigid and prevents the cell from bursting unlike the case in animal cells.
- The cell wall develops a resistant pressure that pushes towards the inside. This pressure is equal and opposite the turgor pressure and is called **wall pressure**.

Diagrams

- When a plant cell is placed in hypertonic solution, water molecules move out of the cell into the solution by osmosis. The cell shrinks and becomes **flaccid**.
- If the cell continues to lose more water, plasma membrane pulls away from the cell wall towards the center.
- The process through which plant cells lose water, shrink and become flaccid is called **plasmolysis**.
- Plasmolysis can be reversed by placing a flaccid cell in distilled water and this process is called **deplasmolysis**.

Study Question 5

Practical Activity 4

Wilting

- When plants lose water through evaporation and transpiration, **cells lose turgidity**, shrink and the plant **droops**. This is called **wilting**.
- If water supply from the soil is inadequate, plants do not recover hence **permanent wilting**.

Study Question 6

Role of Osmosis in Organisms

1. **Absorption of water from the soil**
 - Root hair cells of plants absorb water from the soil by osmosis.
2. **Support**
 - Cells of herbaceous plants, which are less woody, absorb water, become turgid hence support.
3. **Opening and closing of the stomata**
 - During the day, guard cells synthesize glucose, draw in water, become turgid hence open the stomata.
 - During the night, they lose turgidity since there is no photosynthesis. As a result, they shrink thus closing the stomata.
4. **Feeding in insectivorous plants**
 - These plants are able to change their turgor pressure on the leaves which close trapping insects which are digested to provide the plant with nitrogen.
5. **Osmoregulation**
 - In the kidney tubules, water is reabsorbed back to the body by osmosis.

Factors Affecting Osmosis

- i.) Concentration of Solutions and Concentration Gradient. The greater the concentration gradient between two points, the faster the rate of osmosis.
- ii.) Optimum Temperature as long as it does not destroy the semi-permeability of the membrane.

Active Transport

- This is the process that moves substances across cell membranes **against a concentration gradient**.
- This process **requires energy** to move these substances across cell membranes and involves **carriers**.
- Substances such as amino acids, sugar and many ions are taken in by living organisms through active transport.

Role of Active Transport

- i.) Re-absorption of sugars and useful substances by the kidney
- ii.) Absorption of some mineral salts by plant roots
- iii.) Absorption of digested food from the alimentary canal into the blood stream
- iv.) Accumulation of substances in the body to offset osmotic imbalance in arid and saline environment
- v.) Excretion of waste products from body cells

Factors Affecting Active Transport.

- i.) Oxygen concentration.
 - ii.) Change in pH.
 - iii.) Glucose concentration.
 - iv.) Temperature.
- Enzyme inhibitors.

NB/ Any factor affecting energy production affect the rate of active transport.

Practical Activities

1. Experiment to Demonstrate Diffusion

- Various coloured substances such as: dyes, plant extracts and chemicals like potassium permanganate are used.
- Potassium manganate (VII) crystals are introduced to the bottom of a beaker filled with water using a glass tubing or drinking straw which is then removed.
- Observations are made and the disappearance of the crystals and subsequent uniform colouring of water noted.

2. Experiment to Demonstrate Osmosis Using a Visking Tubing

- A strip of visking tubing 8-10 cm is cut and tied at one end using strong thread.
- About 2 ml of 25% sucrose solution is put inside and the other end tied with thread.
- The tubing is washed under running water and then blotted to dry.
- It is immersed in a beaker containing distilled water and left for at least one hour or overnight.
- It will then be observed that the visking tubing has greatly increased in size and has become firm.

- A control experiment can be set up using distilled water inside the visking tubing in place of sucrose solution.

3. Experiment to Show Osmosis using Living Tissue

- Irish potato tubers are peeled and scooped out to make hollow space at the centre.
- Sucrose solution is placed inside the hollow, and the potato tuber placed in a beaker or petri-dish with distilled water. A control is set using a boiled potato.
- Another one using distilled water inside hollow in place of sugar solution.
- The experiment is left for 3 hours to 24 hours.

4. Experiment to Demonstrate Turgor and Plasmolysis in Onion Epidermal Cells

- Two strips of onion epidermis are obtained.
- One is placed on a slide with distilled water while the other is placed on a slide with 25% sucrose solution and a coverslip placed on top of each.
- The mounted epidermis is observed under low power microscope and then left for 30 minutes.
- After 30 minutes, observations are made again.

The cells in distilled water have greatly enlarged. Cells in 25% sucrose have shrunk.

CELL SPECIALIZATION, TISSUES, ORGANS AND ORGAN SYSTEMS

1. Cell specialization

- This is where cells are modified to perform specific functions. Such cells are said to be specialized.
- Examples include the sperm cell which has tail for swimming and the root hair cell which is extended creating large surface area for water absorption.

Specialised Plant and Animal Cells

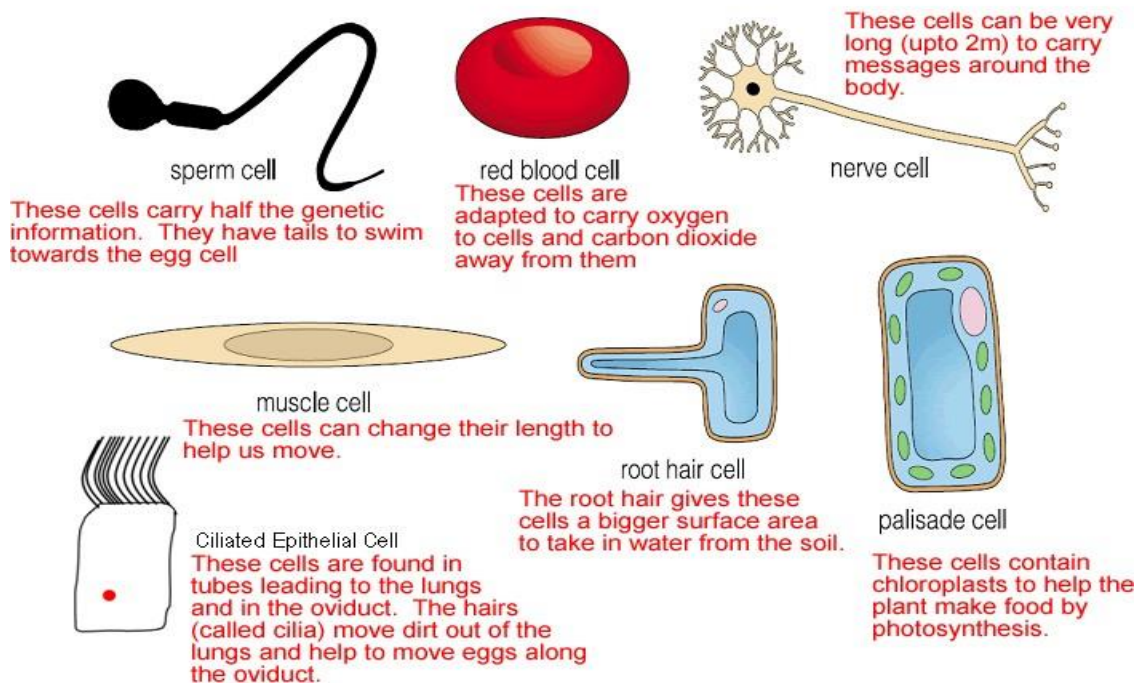

2. Tissues.

- These are cells of a particular type that are grouped together to perform the same function.

Animal tissues include;

- **Epithelial tissue** – which is a thin continuous layer of cells for **lining and protection** of internal and external surfaces.
- **Skeletal** – it is a bundle of elongated cells with fibres that can contract. Its contraction and relaxation brings about movement.
- **Blood tissue** – this is a fluid containing red blood cells, white blood cells and platelets. It transports many substances and protects the body against infections.

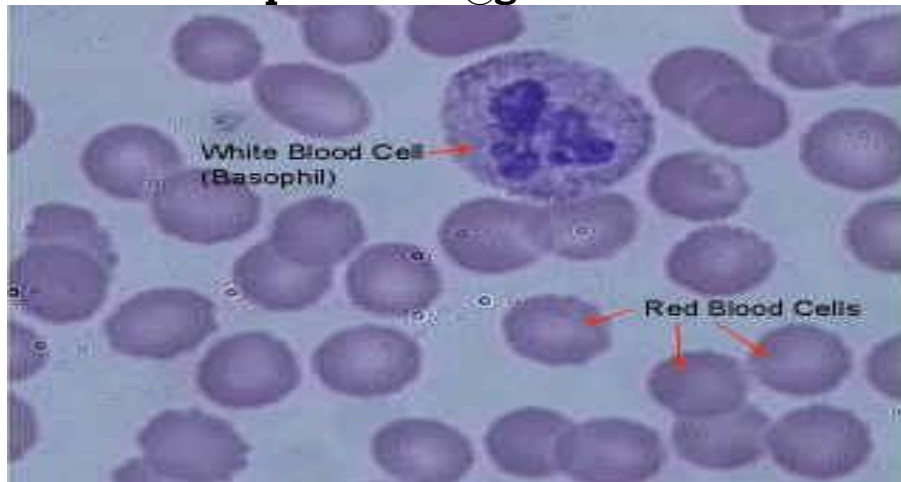

- **Connective tissue** – made up of strong fibres that connect other tissues and organs holding them together.

PLANT TISSUES INCLUDE:

- **Epidermal tissue of a plant** – this is a single layer of cells protecting the inner tissues of the plant.
- **Palisade tissue** – this is a group of cells rich in chloroplasts containing chlorophyll. They absorb light energy during photosynthesis.
- **Parenchyma tissue** – it is made thin walled irregularly shaped cells. They store water and food.
- **Vascular bundle** – consists of the xylem and phloem. Xylem conducts water and mineral salts while phloem conducts food substances.

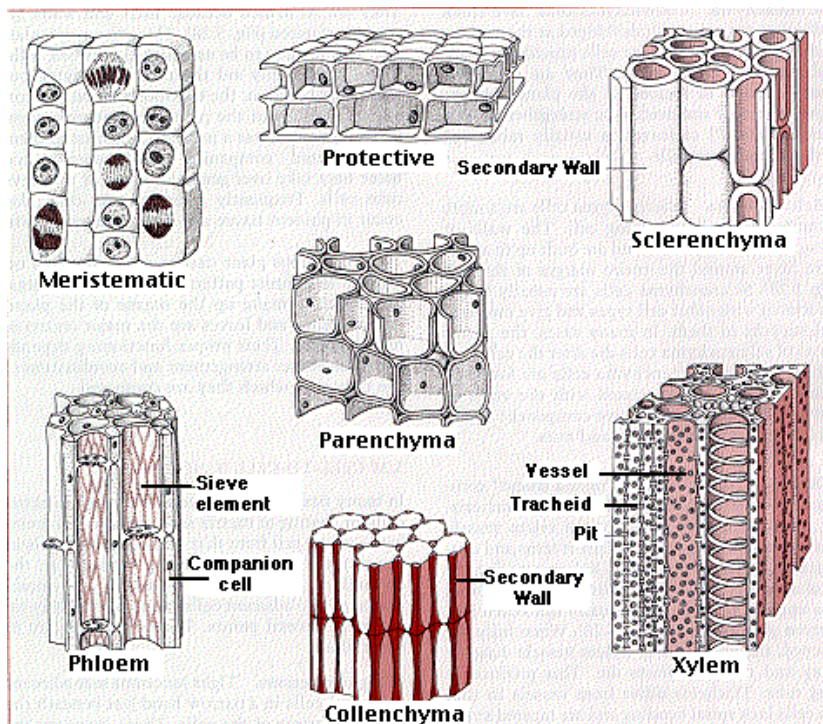

ORGANS

- Many tissues become specialized and grouped together to perform a functional unit called the **organ**.
- Examples of organs in plants include; roots, leaves, flowers and stem.
- In animals they include heart, lungs, kidney, brain, stomach and the liver.

ORGAN SYSTEMS.

- This is made of several organs whose functions are coordinated and synchronized to realize an effective action is called an **organ system**. Examples include; digestive, circulatory, excretory, respiratory, reproductive and nervous system.

NUTRITION IN PLANTS AND ANIMALS

Nutrition

- This is the process by which organisms obtain and Assimilate nutrients.
- There are two modes of nutrition; **Autotrophism and Heterotrophism**.

Autotrophism

- This is where living organism manufacture its own complex food substances from simple substances such as carbon (iv) oxide, water, light or chemical energy.
- Where sunlight is used as a source of energy, the process is referred to as **photosynthesis**.
- Photo** means light while **synthesis** means to make.
- Some **none green plants** make their own food using energy obtained from certain chemicals through a process called **chemosynthesis**.
- Organisms that make their own food are referred to as **autotrophs**.

Heterotrophism

- This is where organisms take in complex food materials such as carbohydrates, proteins and fats obtained from bodies of plants and animals.
- Organisms that feed on already manufactured foods are called **Heterotrophs**.

Autotrophism

External Structure of a Leaf

A leaf is a flattened organ which is attached to the stem or a branch of a plant.

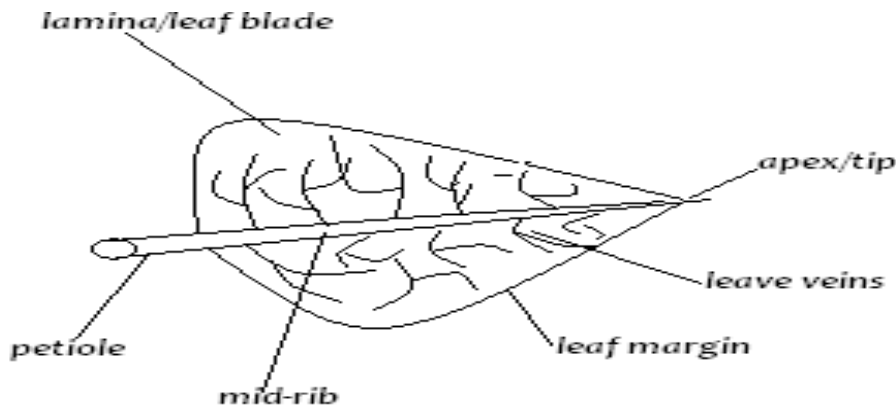

External structure of a leaf

PARTS OF A LEAF

Lamina: This is the flat surface. It is green in colour and contains the photosynthetic tissue.

Midrib: This is a thick structure running through the middle of the leaf. **Veins:** They arise from the midrib to form an extensive network of veins. **Leaf Apex:** This is the tip of the leaf and usually it is pointed.

Petiole: It attaches the leaf to the stem or branch.

In some monocotyledonous plants the leaves are attached to the stem by the leaf sheath.

Practical Activity 1: To examine the External Features of a Dicotyledonous and Monocotyledonous leaf

Study Question 1

Internal Structure of a Leaf

- Internal structure of the leaf is composed of the following parts.

i.) Cuticle.

- It is a thin waterproof and transparent layer that coats the upper and lower surfaces of the leaf.
- It reduces excess water loss and protects the inner tissue of the plant against mechanical injury.
- It also prevents entry of disease-causing microorganisms.
- Since it is transparent, it allows penetration of light for photosynthesis.

ii.) Epidermis.

- It is a one-cell-thick tissue on both the upper and lower leaf surfaces.
- It secretes the cuticle and also protects the inner tissues from mechanical damage and prevents entry of pathogens.
- Epidermal cells have no chloroplast except the **guard cells**.
- Guard cells are special bean-shaped cells. They have chloroplasts and are able to carry out photosynthesis, hence controlling the opening and closing of the stomata.
- Air moves into and out of the leaf through the stomata.

iii.) Palisade layer.

- This is layer of cells located beneath the upper epidermis.
- It is made of cylindrical shaped cells **closely packed** together. They have **numerous chloroplasts** containing chlorophyll.
- Their position and arrangement enables them to receive maximum light.

iv.) Spongy Mesophyll Layer.

- This is below the palisade layer. The cells are **irregularly shaped and loosely packed** creating large air spaces in between them.
- The **air spaces allow gases to diffuse** in between the cells. They contain fewer chloroplasts as compared to the palisade cells.

v.) Leaf Veins.

- Each vein is a vascular bundle consisting of xylem and phloem.
- Xylem conducts water and mineral salts from the roots to the leaves while the phloem translocates manufactured food from the leaves to the rest of the plant.

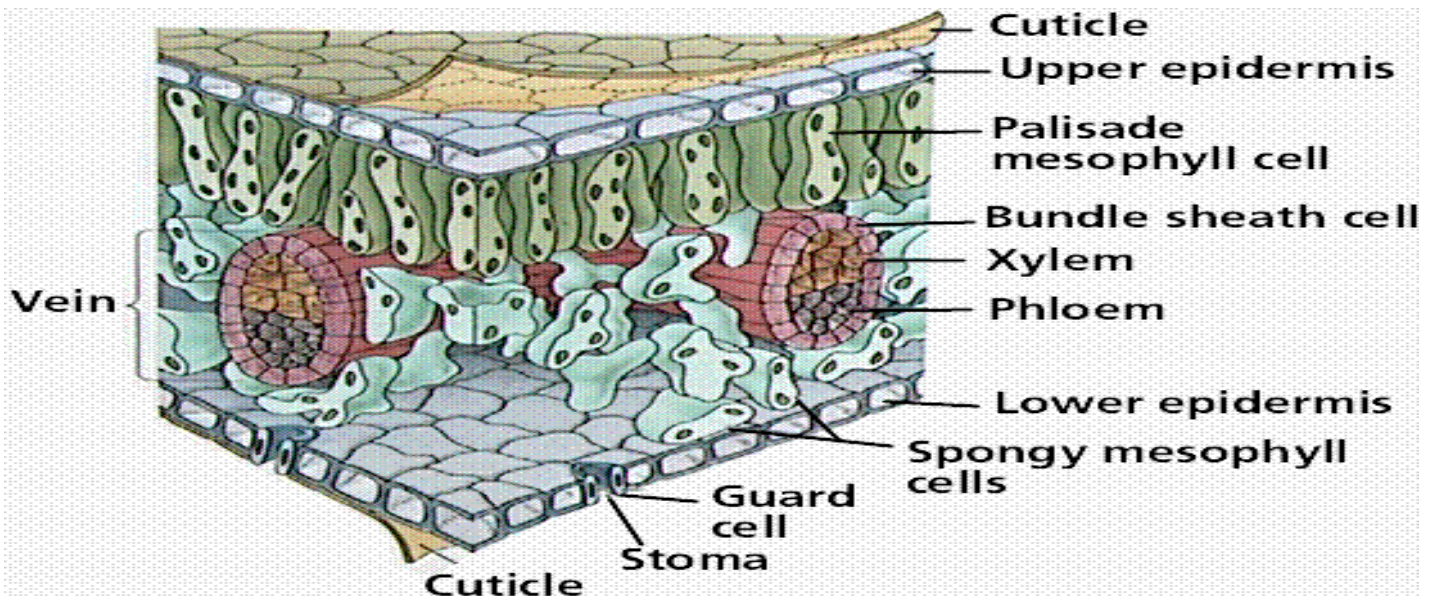

**Study Question
2**

**Adaptations of
Leaves to**

Photosynthesis.

1. Broad and flat lamina to increase surface area of Carbon (IV) oxide and sunlight absorption.
2. Thin transparent cuticle and upper epidermis; to allow easier penetration of light to photosynthetic cells;
3. Thin; for faster diffusion of gases;
4. Palisade cells placed next to the upper surface; to trap maximum light for photosynthesis;
5. Palisade cells with numerous chloroplasts; to trap maximum amount of light for photosynthesis;
6. Large/ intercellular air spaces in the spongy mesophyll layer; for storage of Carbon (IV) oxide for easier gaseous exchange;
7. Waxy water proof cuticle; to reduce water loss and reflect excess light;
8. Leaf mosaic/ non-overlapping leaves; for maximum exposure to light;
9. Guard cells, modified cells to open and close stomata; to control amount of water loss from the leaf and allows gaseous exchange;
10. Leaves have leaf veins; xylem to conduct water to photosynthetic cells, Phloem to translocate products of photosynthesis to other parts of plant;

The Chloroplast

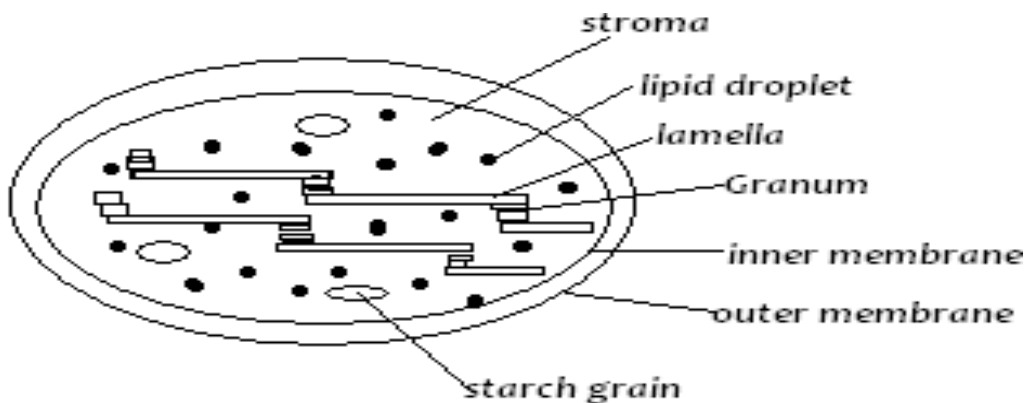

Structure of Chloroplast

- They are disc shaped organelles found in the cytoplasm of plant cells.
- Each chloroplast has a double membrane; the inner and outer membrane.
- Chloroplasts are made of layers of membranes called **lamellae** contained in a fluid matrix called **stroma**.
- Several lamellae come together to form the **granum (grana)**.
- Granum contains **chlorophyll molecules** and other **photosynthetic pigments**.
- The stroma contains **enzymes** that speed up the rate of photosynthesis.

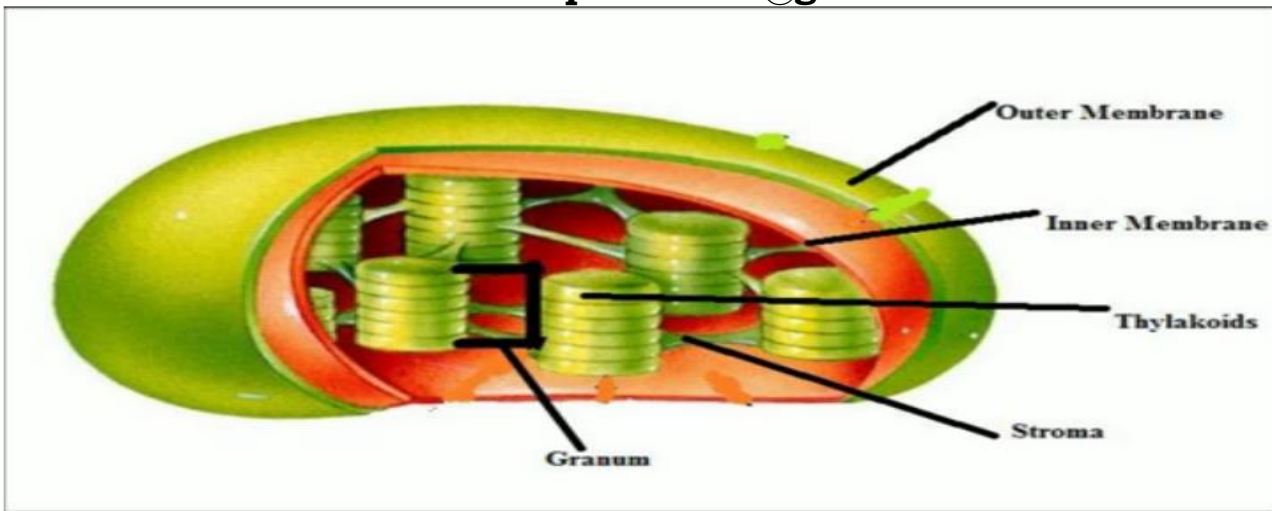

**Practical Activity 2: To Observe Distribution of Stomata
Study Question 3.**

The Process of Photosynthesis

- The raw materials for photosynthesis are; water and carbon (IV) oxide. The process however requires the presence of sunlight energy and chlorophyll Pigment.
- The products of photosynthesis are glucose and oxygen. The process can be summarized using an equation as shown below.



Water + Carbon (IV) oxide —————▶ Glucose + Oxygen.

The above chemical equation translates as:

Six molecules of water plus six molecules of carbon (IV) Oxide produce one molecule of sugar plus six molecules of oxygen

- The process of photosynthesis is however more complex than shown in the above equation and can be divided into two stage; the light and dark stages.

Light stage (Light Dependent Stage)

- Occurs in the grana containing chlorophyll which traps / absorbs sun light energy.
- This Energy is used to split water molecules into hydrogen ion and oxygen gas.
- This process is called **photolysis** of water and is shown below.

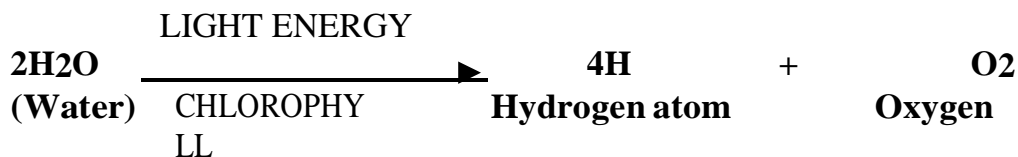

- Hydrogen atoms produced here enter into the dark stage.
- Oxygen gas removed through stomata or is used for respiration within the plant;
- Some Light energy is used in **Adenosine Triphosphate (ATP)** formation; **ATP** an energy rich compound.
- ATP is later used in the dark stage.

Dark stage. (Light Independent Stage)

- Carbon (IV) oxide combines with hydrogen atoms to form glucose/simple carbohydrate.
- This is called Carbon (IV) Oxide fixation.

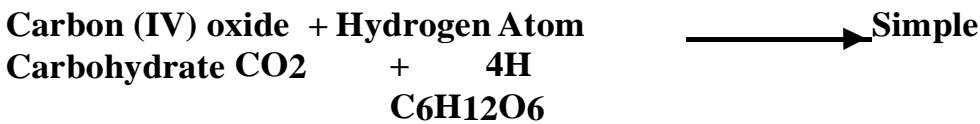

- This stage takes place in the stroma and proceeds whether light is present or not.
- ATP Energy from light stage is used to provide the required energy in this reaction;
- Simple sugars formed are used for respiration to provide energy or are converted to storable forms e.g lipids, proteins, starch, cellulose, etc.

Study Question 4

Practical Activity 3: To Investigate the Presence of Starch in a Leaf.

Study Question 5

FACTORS AFFECTING THE RATE OF PHOTOSYNTHESIS

i.) Light Intensity.

- Increase in light intensity increase the rate of photosynthesis up to a certain level where it slows down and finally levels off.
- Very bright sunshine may damage the plant tissues due to high amount of ultra violet light.
- Light quality or light wavelength also affects the rate of photosynthesis.
- Red and blue wavelengths of light are required by most plants for photosynthesis.

Rate of
Photosynthes
is

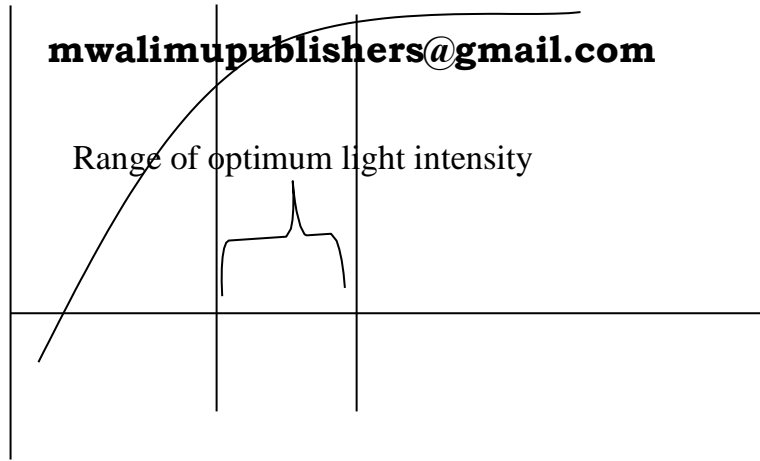

Light intensity

ii.) Carbon (IV) oxide concentration

- Increase in Carbon (IV) oxide concentration increases the rate of photosynthesis linearly up to a certain level after which it slows down and levels off.

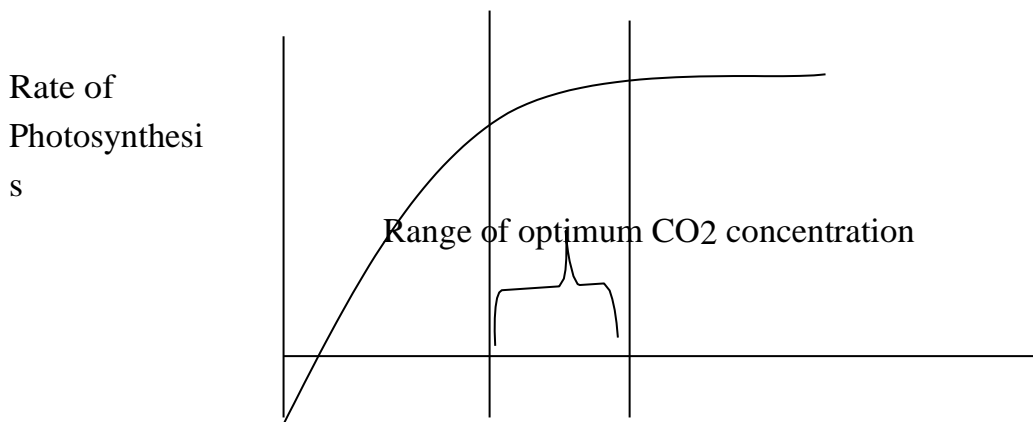

Carbon (IV) oxide concentration

iii.) Temperature

- Photosynthesis is an enzyme controlled process, therefore increase in temperature increase the rate of photosynthesis up to the optimum temperature.
- Increase in temperature beyond the optimum decreases the rate sharply as the enzymes become denatured.

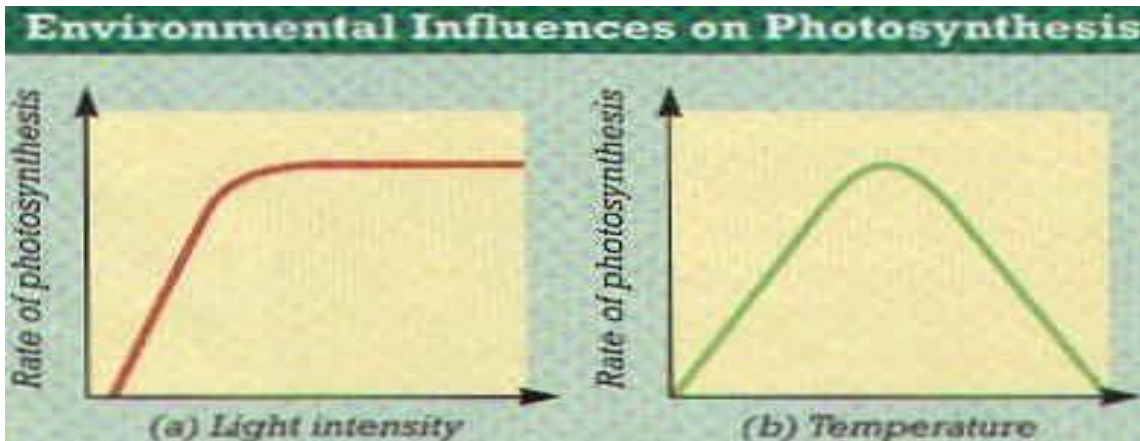

iv.) Water

- Plants need water for photosynthesis. Hydrogen atoms required in the dark stage during Carbon (IV) oxide fixation are derived from water during photolysis.

Study Question 6

Practical Activity 4: To Investigate Factors Necessary for Photosynthesis.

a) Light Study

Question 7

b) Carbon (IV) oxide.

Study Question 8

c) Chlorophyll.

Study Question 9

Study Question 10

Practical Activity 5: To Investigate the Gas Produced During Photosynthesis. Study

Question 11

Chemical Compounds Which Constitute Living Organisms

- Cells, tissues and organs are made of chemicals which are referred to as **chemicals of life**.
 - The study of chemical compounds found in living organisms and reactions in which they take part is called **Biochemistry**.
 - Chemicals of life include carbohydrates, lipids and proteins.
- a) **Carbohydrates**
- They are compounds of carbon, hydrogen and oxygen in the ratio of 1:2:1 respectively.
 - Carbohydrates have a general formula of **(CH₂O)_n** where n represents the number of carbon atoms in a molecule of carbohydrate.
 - Carbohydrates are divided into three groups; **Monosaccharide's, Disaccharides and Polysaccharides**.
- i) **Monosaccharides**
- They are the simplest carbohydrates and have a general chemical formula of **(CH₂O)_n** where n = 6.
 - Their chemical formula is therefore **C₆H₁₂O₆**. They include; glucose, fructose, galactose etc.

Properties of Monosaccharides

- i) They are soluble in water to form sweet tasting solutions.
- ii) They are crystallisable.
- iii) They have the reducing property where they reduce copper sulphate in Benedict's solution to red copper (I) oxide.

Functions

- i) They are oxidized to release energy during respiration.
 - ii) When condensed together, they form polysaccharides such as starch, cellulose or glycogen.
- ii) **Disaccharides**
- They are formed by linking two Monosaccharide molecules through the process

of condensation where a molecule of water is liberated.

Condensation

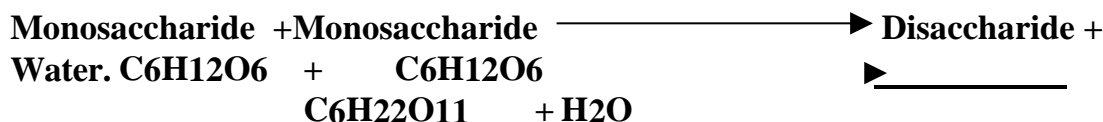

Examples

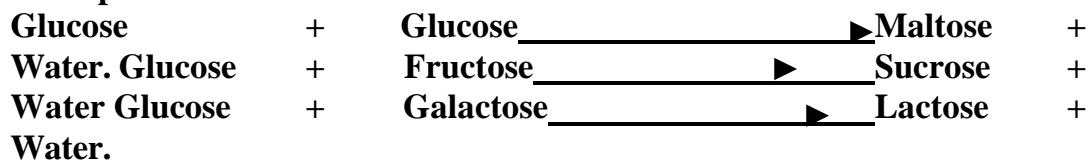

Water.

- The type of disaccharide formed depends on the monosaccharide units that condense together.

Properties of Disaccharides

- i) Soluble in water to form sweet tasting solutions
- ii) They are **non reducing sugars**. Some such as the maltose can reduce copper sulphate in Benedict's solution when heated together and are therefore referred to as **complex reducing sugars**.
- iii) They are readily broken into their constituent monosaccharide molecules in a process known as **Hydrolysis** in the presence of water.

Hydrolysis

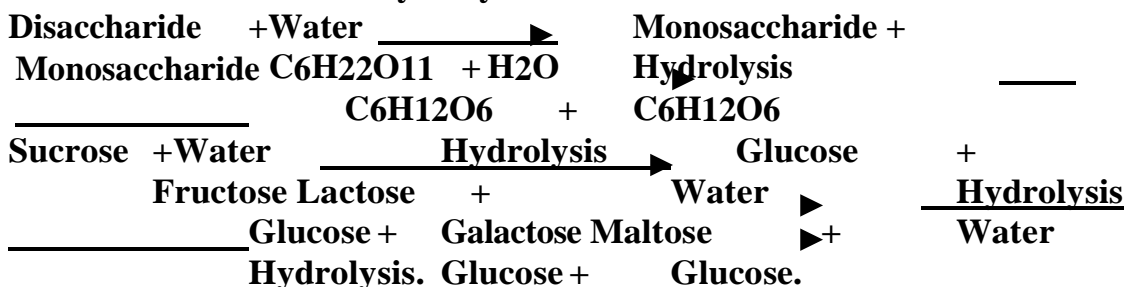

- Naturally disaccharides are hydrolyzed by enzymes. In the laboratory, hydrolysis is achieved by boiling them in dilute Hydrochloric acid.

Functions

- They are hydrolyzed by enzymes into monosaccharide's which are then oxidized to produce energy.
- iii) **Polysaccharides**. They are made of many monosaccharide molecules hence are long and more complex.
 - They have a general formula of $(\text{C}_6\text{H}_{10}\text{O}_5)_n$; where the value of **n** is a very large number.

Examples of polysaccharides

- i) **Starch**
 - It is present as stored food in plant tissues e.g. maize, wheat, potatoes, rice etc.
- ii) **Cellulose**
 - This is the component of the cell wall in plants. Cellulose gives the plant cells their definite shape.

iii) Glycogen

- This is the form in which carbohydrates are stored in animal tissues. Excess glucose is converted into glycogen for storage in the liver.

Properties of Polysaccharides

i) All are insoluble in water

ii) Do not have a sweet taste hence are referred to as non-sugars. **Study**

Question 12

Practical Activity 6: To Carry out Food Tests for Carbohydrates

i) Starch

ii) Reducing sugars

iii) Non Reducing Sugars

b) Lipids

- These are the fats and oils. Fats are found in animals while oils are found in plants.
- Oils are liquid while the fats are solid at room temperature.
- They contain carbon, hydrogen and oxygen just like the carbohydrates. However they contain fewer number of oxygen atoms than in carbohydrates.
- Lipids are made up of three **fatty acid molecules** and one molecule of **Glycerol**.
- The nature of a lipid formed, depends on the fatty acids it contains. Glycerol remains the same in all lipids.

Diagram

- Complex lipids are formed through condensation of many lipid molecules just like in carbohydrates.
- Examples of complex lipids include; phospholipids, waxes, steroids and cholesterol.
- Presence of lipids in a food sample is detected using the **grease spot test or emulsion test**.

Properties of Lipids

1. When fats are heated they change into liquid while oils solidify under low temperature.
2. Both fats and oils are insoluble in water. They however dissolve in organic solvents such as alcohol to form emulsions and suspensions.
3. Lipids are inert hence can be stored in the tissues of organisms.

Functions of Lipids

i) Source of energy

- They give almost twice as much energy as the Monosaccharides.

ii) Source of metabolic water

- When oxidized, lipids release more water than Monosaccharides. Such water is referred to as **metabolic water**.

iii) Structural compounds

- Lipids are constituents of plasma membrane and protoplasm.

iv) Heat insulation

- Fats are deposited under the skin of animals forming the adipose tissue which acts as a heat insulator.

- Mammals in the temperate regions have thick adipose tissue to greatly reduced heat loss
- Thick adipose tissue in aquatic animals helps them to be buoyant in water.

v) **Protection**

- Fat is deposited around the major organs such as kidney, heart etc where they act as shock absorber.
- Wax in plant cuticles reduces excessive water loss.

Study Question 13

Practical Activity 7: testing for the Presence of Lipids

- i) The Grease Spot
- ii) The Emulsion Test

c) **Proteins**

- Like carbohydrates and lipids, proteins are compounds of carbon, hydrogen and oxygen.
- In addition they contain **nitrogen** and sometimes **phosphorous and sulphur**.
- Some proteins such as haemoglobin contain other elements such as iron.
- Proteins are made up of small units called amino acids. There are about 20 different types of amino acids.
- All amino acids contain the amino group (**-NH₂**) which consists of hydrogen and nitrogen.
- Two amino acids combine to form a **dipeptide molecule** through the process of condensation.
- The bond between two amino acids is called **peptide Bond**. Many amino acids join together to form a long protein chain called **polypeptide chain**.
- The **type and sequence** of amino acids contained in such a chain determine the **uniqueness** of the protein being formed.

□

Properties of Proteins

- i.) They dissolve in water to form **colloidal suspensions** (not true solutions) where particles remain suspended in water.
- ii.) They are **denatured by temperatures above 40 °C**. Heat alters the structure of the protein molecule. Chemicals such as detergents, acids, bases and organic solvents also denature proteins.
- iii.) They are **amphoteric** whereby they have both acidic and basic properties.
This property enables them to combine with non-protein compounds to form **conjugated proteins** such as mucus, and haemoglobin. In mucus the non protein compound is a carbohydrate while in haemoglobin, iron is a non protein.

Functions of Proteins

- i.) Structural Functions
 - Proteins make the framework of living systems e.g. plasma membrane, connective tissues, muscle fibres, hair, nails, hooves, skeletal materials etc.
- ii.) Metabolic Regulators

- These are divided into two

a) Enzymes

- Enzymes are **organic catalysts which speed up** the rate of metabolic reactions such as respiration, photosynthesis, digestion etc.

b) Hormones

- They are **chemical messengers which regulate many body processes** such as growth, reproduction, amount of sugars, salts and water in the blood etc.

iii.) **Source of Energy**

- Under extreme starvation, proteins are broken down to release energy.

Study question 14

Practical Activity 8

To Test for Proteins

Enzymes

- They are organic catalysts which are protein in nature. They speed up or slow down the rate of chemical reactions in the body without themselves being used up.

- They are divided into two;

a) Extracellular Enzymes

- Extracellular enzymes are produced within the cells but are used outside the cells which produce them e.g. the digestive enzymes.

b) Intracellular Enzymes

- They are secreted and used within the cells which produce them e.g. the respiratory enzymes.

Naming of the Enzyme

- There are two methods on naming enzymes;

i) Trivial Naming

- Enzymes are given names of persons who discovered them.
- The names end in **-in** such as pepsin, trypsin ptyalin etc.

ii) Use of suffix –ase

- This is the modern method of naming. The suffix –ase is added to the substrate (type of food) or the reaction the enzyme catalyzes.

Example 1

Substrate	Enzyme
Carbohydrate	Carbohydrase
Starch e.g. amylose	Amylase
Sucrose	Sucrase
Maltose	Maltase

Protein	Protease
Lipid	Lipase

Example 2

Reaction	Enzyme
Hydrolysis	Hydrolase
Oxidation	Oxidase
Reduction	Reductase

Properties of Enzymes

1. They are protein in nature hence are affected by changes in temperature and pH.
2. They are substrate specific.
3. They are efficient in small amounts as they are not affected by the reactions they catalyze. They can be used again and again.
4. They are catalysts that speed up the rate cellular reactions and are not used up in the reactions they catalyses.
5. Most of the enzyme controlled reactions are reversible.

Factors Affecting the Rate of Enzyme Controlled Reactions i.)

Temperature

- Enzymes are sensitive to changes in temperature and pH since they are protein in nature.
- Enzymes work best within a narrow range of temperature called the optimum temperature.
- Above the optimum temperature, reaction decreases sharply as the enzymes are denatured.
- Most enzymes have optimum temperature between 35-40°C.
- Very low temperature inactivates the enzymes hence decrease rate of reaction.

Diagrams

ii.) pH

- Most enzymes have a pH of close to 7.
- Some however work best in acidic pH e.g. pepsin while others work best in alkaline conditions.
- As pH changes from the optimum, enzyme activity decreases.
- Extreme acidity or alkalinity denatures most enzymes.

Diagrams

iii.) Specificity

- Enzymes are specific in nature where a particular enzyme acts on a particular

specific substrate.

- For example, sucrose works on sucrose and not any other substrate. iv.)
Substrate Concentration and Enzyme Concentration.
- When substrate concentration increases, the rate of enzyme reaction also increases up to a certain level.
- Further increase does not increase the rate of reaction as **all the active sites** of an enzyme are occupied.
- When enzyme molecules are increased, the rate of reaction increases proportionally.

Diagrams

v.) Enzyme Co-factors and Co-enzymes

- Co-factors are non protein substances which activates enzymes. They are required in small quantities and they include metallic ions such as those of iron, magnesium, zinc, copper etc. Some are vitamins.
- Co-enzymes are non protein molecules that work in association with particular enzymes. Most co-enzymes are derived from vitamins.

vi.) Enzyme Inhibitors

- Inhibitors compete with the normal substrate for the active sites and they take up the active site of the enzyme permanently.
- There are two types of inhibitors;

a) Competitive Inhibitors

- These are chemicals closely related to normal substrate and they compete for active sites with the normal substrate. They slow down the rate of reaction.

b) Non Competitive Inhibitors

- They do not compete with the substrate. They combine permanently with enzyme molecules thus blocking the active sites. They include poisons such as cyanides, mercury and silver-arsenic compounds.

Importance of Enzymes

- Enzymes speed up the rate of cellular reactions and also control them. This way, they help prevent violent reactions in the cells.

Study Question 15

Practical Activity 9

Study Question 16

Study Question 17

Practical Activity 10

NUTRITION IN ANIMALS (HETEROTROPHISM)

Meaning and Types of Heterotrophism

- This is a mode of nutrition whereby organisms feed on complex organic matter from other plants or animals.
- All animals are heterotrophs.
- Their mode of feeding is also said to be holozoic to distinguish it from other special types of heterotrophic nutrition namely:
 - saprophytism
 - parasitism.
- Saprophytism/saprotrophism- occurs in most fungi and some forms of bacteria.
- Saprophytes feed on dead organic matter and cause its decomposition or decay.
- Parasitism is a mode of feeding whereby one organism called the parasite feeds on or lives in another organism called the host and harms it.

Modes of Feeding in Animals

- Animals have developed various structures to capture and ingest food.
- The type of structures present depend on the method of feeding and the type of food.
- **Carnivorous** animals feed on whole animals or portions of their flesh.
- **Herbivorous** animals feed on plant material.
- **Omnivorous** animals feed on both plants and animal materials.

Feeding in Mammals

- The jaws and teeth of mammals are modified according to the type of food eaten.
- Mammals have different kinds of teeth.
- Each type of teeth has a particular role to play in the feeding process.

Feeding in Mammals

- The jaws and teeth of mammals are modified according to the type of food eaten.
- Mammals have different kinds of teeth.
- Each type of teeth has a particular role to play in the feeding process.
- This condition is described as heterodont.
- The teeth of reptiles and amphibians are all similar in shape and carry out the same function.
- They are said to be homodont.

Types of Mammalian Teeth

- Mammals have four kinds of teeth.
- The incisors are found at the front of the jaw.
- They are sharp-edged and are used for biting.
- The canines are located at the sides of the jaw.

- They are pointed and are used for tearing and piercing.
- The premolars are next to the canines and the molars are at the back of the jaw.
- Both premolars and molars are used for crushing and grinding.
- Teeth are replaced only once in a lifetime.
- The first set is the milk or deciduous teeth.
- These are replaced by the second set or the permanent teeth.

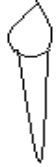

canine



incisor



premolar



molar

Different types of teeth in humans

- Dentition refers to the type of teeth, the number and their arrangement in the jaw.
- A dental formula shows the type and number of teeth in each half of the jaw.
- The number of teeth in half of the upper jaw is represented above a line and those on the lower jaw below the line.
- The first letter of each type of teeth is used in the formula i.e. i = incisors, c = canines, pm = premolars and m = molars.
- The total number is obtained by multiplying by two (for the two halves of each jaw).

Adaptation of Teeth to Feeding

- In general, incisors are for cutting, canines for tearing while premolars and molars are for grinding.
- However, specific modifications are observed in different mammals as an adaptation to the type of food they eat.
- Teeth of Herbivores
 - Incisors are long and flat with a sharp chisel-like edge for cutting.
 - The enamel coating is thicker in front than at the back so that as the tooth wears out, a sharp edge is maintained.
 - Canines are reduced or absent.
 - If absent, the space left is called the diastema.

- The diastema allows the tongue to hold food and push it to the grinding teeth at the back of the mouth.

Premolars and molars:

- These are transversely ridged.
- The ridges on the upper teeth fit into grooves on the lower ones.
- This gives a sideways grinding surface.
- The teeth of herbivores have open roots i.e., wide opening into the pulp cavity.
- This ensures a continued adequate supply of food and oxygen to the tooth.
- In some herbivores, such as rabbits and elephants, the incisors continue to grow throughout life.

Teeth of Carnivores

- Incisors are reduced in size and pointed.
- They are well suited for grasping food and holding prey.
- Canines are long, pointed and curved.
- They are used for piercing and tearing flesh as well as for attack and defence.
- **Premolars and molars:** In general, they are long and longitudinally ridged to increase surface area for crushing.
- **Carnassial Teeth:** These are the last premolars on the upper jaw and the first molars on the lower one.
- They are enlarged for cutting flesh.
- They act as a pair of shears.
- They also crush bones.
- The teeth of carnivores have closed roots i.e., only a very small opening of the pulp cavity to allow food and oxygen to keep teeth alive.
- Once broken, no re-growth can take place.

Teeth of Omnivores

- Incisors have a wide surface for cutting.
- Canines are bluntly pointed for tearing.
- Premolars and molars have cusps for crushing and grinding.
- The premolars have two blunt cusps while the molars have three to four.

Internal Structure of tooth

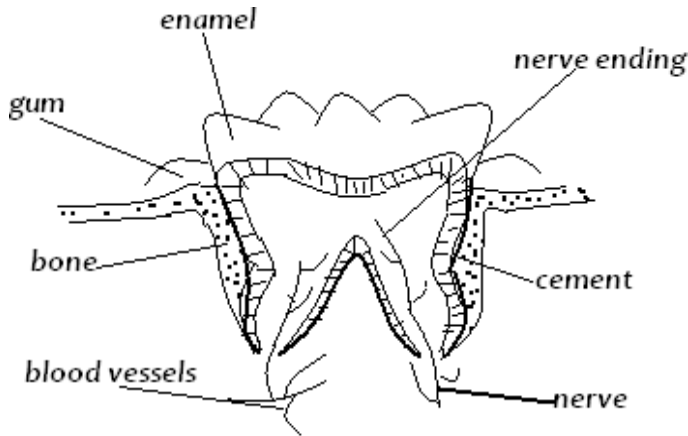

Internal structure of a tooth

The tooth consists of two main parts:

Crown: The portion above the gum; it is covered by the enamel.

Root: The portion below the gum; it is covered by the cement.

➤ The tooth has two roots.

Neck: Is the region at the same level with the gum.

➤ It forms the junction between the crown and the root.

➤ It is covered by enamel. Incisors and canines have one root only.

➤ Premolars have one or two roots while molars have two to three roots each.

➤ Internally, the bulk of the tooth is made up of dentine which consists of living cells and extends to the root.

➤ It is composed of calcium salts, collagen and water.

➤ It is harder than bone but wears out with use.

➤ This is why it is covered by enamel which is the hardest substance in a mammal's body.

Pulp Cavity: Contains blood vessels which provide nutrients to the dentine and remove waste products.

➤ It also contains nerve endings which detect heat, cold and pain. **Cement:**

Fixes the tooth firmly to the jaw bone.

COMMON DENTAL DISEASES

Dental Carries

- Dental carries are the holes or cavities that are formed as acid corrodes enamel and eventually the dentine.
- **Causes**
 - This is caused by bacteria acting on the food left between teeth and on the cusp.
 - Acids are formed that eventually corrode the enamel.
 - The pulp cavity is eventually reached.
 - A lot of pain is experienced then
 - The bacteria then infect the pulp cavity and the whole tooth decays.
- **Treatment**
 - Treatment depends on the extent of the dental caries:
 - Extraction of Tooth.
 - Filling - this involves replacing the dentine with amalgam, a mixture of hard elements e.g. silver and tin.
 - Root Canal Treatment - This involves surgery and reconstruction.
 - It saves severely damaged teeth.
 - The nerves in the root canal are surgically severed.
 - The tooth is cleaned and filled up with amalgam.

Periodontal Diseases

- These are diseases of the gum.
- The gum becomes inflamed, and starts bleeding.
- Progression of the disease leads to infection of the fibres in the periodontal membranes and the tooth becomes loose.
- This condition is known as pyorrhoea.
- The diseases are caused by poor cleaning of the teeth.
- The accumulation of food particles leading to formation of plaque, lack of adequate vitamin A and C in the diet.

Treatment

- Nutrition - by taking adequate balanced diet rich in vitamins A and C.
- Antibiotics are used to kill bacteria.
- Anti-inflammatory drugs are given.
- Antiseptic is prescribed to use in cleaning the mouth daily to prevent further proliferation of bacteria.
- The plaque is removed-drilled away - a procedure known as scaling.

Care of Teeth

In order to maintain healthy teeth the following points should be observed:

- A proper diet that includes calcium and vitamins, particularly vitamin D is essential.
- The diet should also contain very small quantities of fluorine to strengthen the enamel.
- Large quantities of fluorine are harmful.
- The enamel becomes brown, a condition known as dental fluorosis.
- Chewing of hard fibrous foods like carrots and sugar cane to strengthen and cleanse the teeth.

- Proper use of teeth e.g. not using teeth to open bottles and cut thread.
- Regular and thorough brushing of teeth after meals.
- Dental floss can be used to clean between the teeth.
- Not eating sweets and sugary foods between meals.
- Regular visits to the dentist for check-up
- Washing the mouth with strong salt solution or with any other mouth wash with antiseptic properties.

Digestive System and Digestion in Humans

- Organs that are involved with feeding in humans constitute the digestive system.

Digestive System and Associated Glands

- Human digestive system starts at the mouth and ends at the anus.
- This is the alimentary canal.
- Digestion takes place inside the lumen of the alimentary canal.
- The epithelial wall that faces the lumen has mucus glands (goblet cells).
- These secrete mucus that lubricate food and prevent the wall from being digested by digestive enzymes.
- Present at specific regions are glands that secrete digestive enzymes.
- The liver and pancreas are organs that are closely associated with the alimentary canal.
- Their secretions get into the lumen and assist in digestions.

Digestive system consists of:

- Mouth.
- Oesophagus.
- Stomach.
- Small intestines - consist of duodenum, the first part next to the stomach, ileum - the last part that ends up in a vestigial caecum and appendix which are non-functional.
- Large intestines consist of: colon and rectum that ends in the anus.

Ingestion, Digestion and Absorption

- Feeding in humans involves the following processes:
- Ingestion: This is the introduction of the food into the mouth.
- Digestion: This is the mechanical and chemical breakdown of the food into simpler, soluble and absorbable units.
- Absorption: Taking into blood the digested products.
- Assimilation: Use of food in body cells.

- Mechanical breakdown of the food takes place with the help of the teeth
- Chemical digestion involves enzymes.

Digestion in the Mouth

- In the mouth, both mechanical and chemical digestion takes place.
- Food is mixed with saliva and is broken into smaller particles by the action of teeth.
- Saliva contains the enzyme amylase.
- It also contains water and mucus which lubricate and soften food in order to make swallowing easy.
- Saliva is slightly alkaline and thus provides a suitable pH for amylase to act on cooked starch, changing it to maltose.
- The food is then swallowed in the form of semisolid balls known as boluses.
- Each bolus moves down the oesophagus by a process known as peristalsis.
- Circular and longitudinal muscles along the wall of the alimentary canal contract and relax pushing the food along.

Digestion in the Stomach

- In the stomach, the food is mixed with gastric juice secreted by gastric glands in the stomach wall.
- Gastric juice contains pepsin, rennin and hydrochloric acid.
- The acid provides a low pH of 1.5-2.0 suitable for the action of pepsin.
- Pepsin breaks down protein into peptides.
- Rennin coagulates the milk protein casein.
- The stomach wall has strong circular and longitudinal muscles whose contraction mixes the food with digestive juices in the stomach.

Digestion in the Duodenum

- In the duodenum the food is mixed with bile and pancreatic juice.
- Bile contains bile salts and bile pigments.
- The salts emulsify fats, thus providing a large surface area for action of lipase.
- Pancreatic juice contains three enzymes:
 - Trypsin which breaks down proteins into peptides and amino acids,
 - Amylase which breaks down starch into maltose, and
 - Lipase which breaks down lipids into fatty acids and glycerol.
- These enzymes act best in an alkaline medium which is provided for by the bile.

Digestion in ileum

- Epithelial cells in ileum secrete intestinal juice, also known as succus entericus.
- This contains enzymes which complete the digestion of protein into amino acids,

carbohydrates into monosaccharides and lipids into fatty acids and glycerol.

Absorption

- This is the diffusion of the products of digestion into the blood of the animal.
- It takes place mainly in the small intestines though alcohol and some glucose are absorbed in the stomach.

The ileum is adapted for absorption in the following ways:

- It is highly coiled.
- The coiling ensures that food moves along slowly to allow time for its digestion and absorption.
- It is long to provide a large surface area for absorption.
- The epithelium has many finger-like projections called villi (singular villus).
- They greatly increase the surface area for absorption.
- Villi have microvilli that further increase the surface area for absorption.
- The wall of villi has thin epithelial lining to facilitate fast diffusion of products of digestion.
- Has numerous blood vessels for transport of the end products of digestion.
- Has lacteal vessels; for absorption of fatty acids and glycerol and transport of lipids.

Absorption of Glucose and Amino Acids

- Glucose and other monosaccharides as well as amino acids are absorbed through the villi epithelium and directly into the blood capillaries.
- First they are carried to the liver through the hepatic portal vein, then taken to all organs via circulatory system.

Absorption of Fatty Acids and Glycerol

- Fatty acids and glycerol diffuse through the epithelial cells of villi and into the lacteal.
- When inside the villi epithelial cells, the fatty acids combine with glycerol to make tiny fat droplets which give the lacteal a milky appearance.
- The lacteals join the main lymph vessel that empties its contents into the bloodstream in the thoracic region.
- Once inside the blood, the lipid droplets are hydrolysed to fatty acids and glycerol.

Absorption of Vitamins and Mineral Salts

- Vitamins and mineral salts are absorbed into the blood capillaries in the villi. Water is mainly absorbed in the colon.
- As a result the undigested food is in a semi-solid form (faeces) when it reaches the rectum.
- **Egestion:** This is removal of undigested or indigestible material from the body. Faeces are temporarily stored in the rectum then voided through the anus.

Opening of the anus is controlled by sphincter muscles

- **Assimilation:** This is the incorporation of the food into the cells where it is used for various chemical processes.

Carbohydrates

- used to provide energy for the body.
- Excess glucose is converted to glycogen and stored in the liver and muscles.
- Some of the excess carbohydrates are also converted into fat in the liver and stored in the adipose tissue' (fat storage tissue), in the mesenteries and in the connective tissue under the skin, around the heart and other internal organs.

Proteins

- Amino acids are used to build new cells and repair worn out ones.
- They are also used for the synthesis of protein compounds.
- Excess amino acids are de-aminated in the liver.
- Urea is formed from the nitrogen part.
- The remaining carbohydrate portion is used for energy or it is converted to glycogen or fat and stored.

Lipids

- Fats are primarily stored in the fat storage tissues.
- When carbohydrates intake is low in the body, fats are oxidised to provide energy.
- They are also used as structural materials e.g. phospholipids in cell membrane. They act as cushion, protecting delicate organs like the heart.
- Stored fats under the skin act as heat insulators.

Summary of digestion in humans

Digestive and juice produced	pH	Contents	Food	Products	Notes
Salivary glands (Salivary)	7.4	Water, and salts			Soften and lubricate food, provide neutral pH.
		Amylase	Starch	Maltose	Glucose if food stays longer in mouth.
					Not an enzyme but

Stomach	1'. 8	Hydrochl ori acid	Nucle o- protei ns	Nucleic + protein	the nuclear proteins. 1. Kills micro-organisms. 2. Provides acidic medium. 3. Activates enzyme pepsinogen and protennin.
(Gastric Juice)				Cur d -	

		Rennin	Milk protein	coagulated milk (casein)	abundant in infants prorennin.
		Pepsin	Protein	Peptones	Secreted as pepsinogen
Pancreas (Pancreatic juice)	8.8	Trypsin	Protein	Peptones	Secreted as trypsinogen activated by enterokinase trypsin
		Chymotrypsin	Peptones, casein	Amino acids	Secreted as chymotrypsin activated to trypsin.
		Amylase	Starch glycogen	Maltose Maltose	
		Lipase	Lipids	Fatty acids and	PH in duodenum lowered by acid from stomach
		Sodium bicarbonate			Provides alkaline conditions
				Peptidases (erepsin)	Peptides
Ileum (succus entericus)	8.3	Invertase made of sucrase	Sucrose	Fructose + glucose	
		Lactase	Lactose	Galactose glucose	
		Maltase	Maltose	Glucose	
		Lipase	Lipids	Fatty acids and	
		Enterokinase			Activates trypsinogen to trypsin.

Importance of Vitamins, Mineral Salts, Roughage and Water in Human Nutrition

Vitamins

- These are organic compounds that are essential for proper growth, development and functioning of the body.
- Vitamins are required in very small quantities.
- They are not stored and must be included in the diet.
- Vitamins Band C are soluble in water, the rest are soluble in fat.

- Various vitamins are used in different ways.

Mineral Salts

- Mineral ions are needed in the human body.
- Some are needed in small amounts while others are needed in very small amounts (trace).
- All are vital to human health.
- Nevertheless, their absence results in noticeable malfunction of the body processes.

Water

- Water is a constituent of blood and intercellular fluid.
- It is also a constituent of cytoplasm.
- Water makes up to 60-70% of total fresh weight in humans.
- No life can exist without water.

Functions of Water

- Acts as a medium in which chemical reactions in the body takes place.
- Acts as a solvent and it is used to transport materials within the body.
- Acts as a coolant due to its high latent heat of vaporisation.
- Hence, evaporation of sweat lowers body temperature.
- Takes part in chemical reactions i.e. hydrolysis.

Vitamins, sources, uses and the deficiency disease resulting from their absence in diet

Name of Vitamin	Sources	Uses in body	Deficiency
A (retinol) Soluble	Liver, egg-yolk, carrots, milk, spinach	Synthesis of rhodopsin, Control of growth of epithelium	Hardening of cornea of the eye (xerophthalmia), poor night resistance to diseases of skin is reduced.
B, (Thiamine)	Yeast, whole grain, liver, kidney, beans, meat, spinach	Formation f the enzyme carboxylase important in conversion of pyruvic respiration.	Beriberi - swelling of the feet; slowing of heartbeat and intestinal disorder.
B2 (Riboflavin)	Whole grain, eggs, milk, groundnuts, cheese, yeast	Formation of flavoprotei ns that form	Sores on tongue surface and comers of the mouth.

	Liver, kidneys, whole grain.	Makes co-enzyme 1 and 2 co-enzyme A needed in respiration.	nervous disorders leading to
B, (Pantothenic acid)	In most foods	Forms parts of co-enzyme A.	Poor co-ordination of nervous muscle cramp.
B6 (Pryidoxine) water soluble	Eggs, kidneys, whole grain, vegetables.	Makes a co-enzyme for amino acids metabolism.	Irritability, depression, dermatitis.

	Milk, eggs, liver, vegetables, bananas.	In intracellular body fluids transmission.	Nervour transmission interfered with.
Chloride p	Table salt, sea foods.	Present in tissue fluid. water balance essential for	

		digestion. Constituent of hydrochloric acid.	
Magnesium	Green vegetables.	Also needed as a co-factor respirator enzymes. Muscle contraction.	
Iodine	Iodised table salt and food.	Constituent of the hormone thyroxine that controls metabolism.	In young animals leads cretinism. Simple goitre adults.
Manganese	Eggs, milk, fish.	Activates certain enzymes.	
Iron	Liver, green vegetable leaves, lean meat, grains, milk.	A constituent of haemoglobin and myoglobin.	Anaemia.
Sulphur	Protein foods	A constituent of some needed in synthesis of certain enzymes and phospholipids in cell membranes.	
Copper		Catalyses use of iron, a constituent of cytochrome oxidase (an enzyme)	Needed in very small amounts.
Cobalt		Influences the use of iron (found in Vitamin ~2)	Needed in very small amounts.
	Fruits and vegetable s. Seeds of	Needed for proper growth insulin.	Needed in very small amounts.
Fluorine	Water, fruits and vegetables.	Strengthening of enamel	Needed in small amounts.
Molybdenum	Plant seeds	Activates enzyme system in nucleic acid metabolism.	Very small amounts needed, excess is dangerous.
Chromium		Involved in use of	Needed in small

Roughage

- Roughage is dietary fibre and it consists mainly of cellulose.
- It adds bulk to the food and provides grip for the gut muscles to enhance peristalsis.
- Roughage does not provide any nutritional value because humans and all animals not produce cellulase enzyme to digest cellulose.
- In herbivores symbiotic bacteria in the gut produce cellulase that digests cellulose.

Factors Determining Energy Requirements in Humans

- **Age:** Infants, for instance, need a greater proportion of protein than adults.
- **Sex:** males generally require more carbohydrates than females.
- The requirements of specific nutrients for females depends on the stage of development in the life cycle.
- **Adolescent girls** require more iron in their diet; expectant and nursing mothers require a lot of proteins and mineral salts.
- **State of Health:** A sick individual requires more of certain nutrients e.g. proteins, than a healthy one.
- **Occupation:** An office worker needs less nutrients than a manual worker.

Balanced Diet

- A diet is balanced when it contains all the body's nutrient requirements and in the right amounts or proportions.

A balanced diet should contain the following:

- Carbohydrates
- Proteins
- Lipids
- Vitamins
- Mineral Salts
- Water
- Dietary fibre or roughage

Malnutrition

- This is faulty or bad feeding where the intake of either less or more than the required amount of food or total lack of some food components.

Deficiency Diseases

- Deficiency diseases result from prolonged absence of certain components in the diet.

Examples are:

Marasmus:

- Lack of enough food results in thin arms and legs,
 - severe loss of fluid,

- general body wasting
- sunken eyes.

- **Kwashiorkor –**

- Lack of protein in the diet of children.
- The symptoms of kwashiorkor include wasting of the body, red thin hair, swollen abdomen and scaly skin.
- Other deficiency diseases are due to lack of accessory food factors (vitamins and mineral salts.). Such diseases include rickets, goitre and anaemia.
- Treatment of these deficiency diseases is by supplying the patient with the component missing in the diet.

TOPICAL QUESTIONS FOR BIOLOGY

FORM I TOPICS

1. a) Define biology

-the study of life/living things

b) List the branches of biology

- Zoology (study of animals)
- Botany (study of plants)
- Microbiology (study of microorganisms)

c) Explain the importance of biology

- helps to solve environmental problems
- Helps to learn scientific skills
- For entry into other professions/careers
- To apply knowledge to everyday life situations
- To classify organisms into their right groups
- understanding living organisms

d) State the characteristics of living organisms

- feeding/nutrition
- Growth and development
- respiration (to produce energy)
- sensitivity/irritation/response
- excretion (getting rid of metabolic waste material)
- movement/locomotion
- reproduction

e) State the main differences between plants and animals

Animals	Plants
Specialized excretory organs	No specialized excretory organs
Respond to stimulus quickly	Slow respond to stimulus
All body parts grow equally (intercalary)	Grow at shoot tip and root tip only
Move around to look for food	Stationery
Heterotrophic	Autotrophic
Cells have no cell walls	Cells have cell wall made of cellulose
No chlorophyll	Contain chlorophyll
Give parental care to young	Plants don't care for their young

2. a) i) What is a hand lens?

- Convex lens mounted on a frame and used to magnify small objects for viewing.

ii) How is a hand lens used?

- place the lens a short distance from the eye
- Bring the object to be viewed near the lens until an enlarged and clear image can be seen.

ii) When is a hand lens used?

- For reasonably sized objects such as insect wing, leg, flower parts.
- Cannot be used for small objects such as cells, stomata.

iv) Explain how to calculate drawing magnification

- drawing magnification equals to length of drawing divided by length of object or image length
divided by actual length i.e. $\frac{\text{length of drawing}}{\text{Length of object actual length}}$ or $\frac{\text{image length}}{\text{image length}}$

b) i) what is classification?

- Orderly arrangement of living organisms into various groups according to their similarities

ii) List the external features used to classify plants

- rhizoids(e.g. mosses)
- Frond (e.g. ferns)
- roots e.g. taproot, fibrous roots, modified roots
- flowers
- leaves
- buds
- seeds

iii) List the external features used to classify animals

- horns e.g. cattle, goat, sheep, deer, gazelle etc
- hooves e.g. cattle, sheep, donkey
- mammary glands e.g. cattle, dog, sheep, cat
- hair e.g. human, cat
- Shell e.g. snail, Tortoise
- spines e.g. hedge hog, porcupine

c) Give the reasons why classification is important

- Placing/grouping living organisms into correct groups called taxa
- Identification
- arrange information about living organisms into orderly and sequential manner i.e. it is easy to study organisms in groups
- helps in understanding evolutionary relationships
- monitoring disappearance and appearance of organisms i.e. predict characteristics of organisms

d) i) Name the taxonomic units of classification in descending order

- Kingdom (largest unit)
- Phylum (animals)/division (plants)
- Class
- Order
 - Family
 - Genus
 - Species(smallest unit)

ii) What is a species?

- all organisms which can interbreed and give rise to fertile (viable) offspring

iii) Name the major kingdoms used in classification

- monera
- protocista/protista
- fungi
- plantae
- animalia

e) i) Define the term binomial nomenclature

- a scientific system of naming organisms using the generic/genus and specific/species names
- e.g. for humans, Homo sapiens

ii) State the principles followed during binomial nomenclature

- the first (generic) name should begin with a capital letter while the rest are small letters the two names are printed in italics and if handwritten should be underlined each separately

iii) Give the advantages of using binomial nomenclature

- no confusion about which organism is referred to
- names are internationally accepted regardless of language
- shows evolutionary relationship hence easy to understand
- useful in naming many species unlike use of common names

iv) Name the types of classification

- traditional (using common names)
- scientific(using binomial nomenclature)

3. a) i) Define the term cell

- it is the basic unit of organization of an organism i.e. the basic functional and structural unit of an organism.

ii) What is cell biology?

- study of structure and functioning of a cell
- also called cytology

b)i) What is a microscope?

- an instrument used to magnify objects and make them appear bigger.

ii) Name the types of microscope

- the light microscope
- the electron microscope

iii) State the purpose of using a light microscope

- it magnifies and reveals the structure details of tiny objects such as the cell, that cannot be seen by the human eye directly

-

iv) Draw a labeled sketch of a light microscope

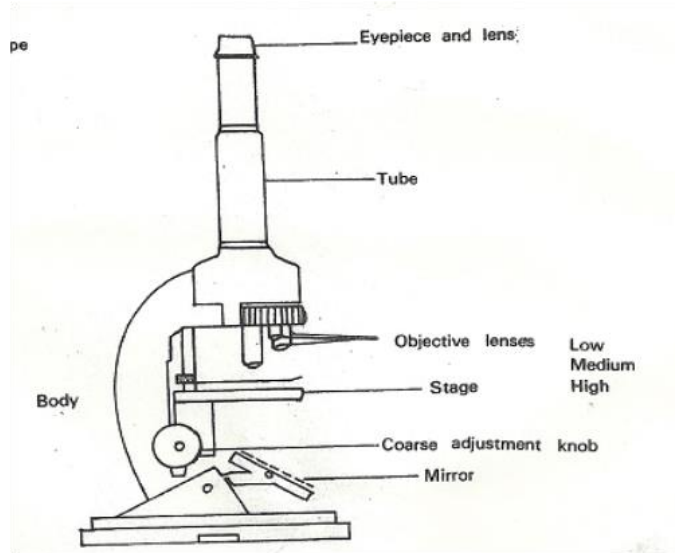

v) State the functions of the labeled parts

- a.) **Eyepiece** used to look through and to magnify the object
- b.) **Course adjustment knob** raises or lowers body tube and focuses object roughly
- c.) **Fine adjustment knob** raises or lowers body tube by small distances to bring image into fine focus
- d.) **objective lens** brings image into focus and also magnifies object/image

- **stage** is a platform where object or specimen on slide is placed
- **mirror** reflects light through condenser and directs it to objective lens
- **clips** hold glass slide in position
- **body tube** holds eyepiece and revolving nose piece which has objective lenses
- **limb** or base support whole instrument
- **arm** for holding when carrying instrument
- **revolving nose piece** holds objective lens in place enabling change from one objective lens to another

e) i) Explain the procedure followed when using a microscope

- put the microscope on the bench with the stage facing away from you (viewer)
- turn the lower power objective to click in line with the eyepiece
- Ensure that the diaphragm/iris is fully open
- Adjust the mirror until the stage is illuminated with enough light
- Place the slide containing the specimen on the stage for magnification
- Draw the image and indicate magnification of the drawing.

ii) State the precautions that are necessary when handling a microscope

- always use two hands when carrying it
- never place a microscope too close to the edge of the bench or table
- do not touch the mirror and lens with wet or dirty hands
- clean dirty lenses using a special lens cleaning cloth
- clean other parts using a soft cloth or tissue paper
- low power objective must click into position before and after use.
- Do not wet any part of the microscope
- Clean and store well after use

d) i) What is magnification?

- The power of making an image larger

ii) Give the formula used to calculate magnification in a light microscope

- eyepiece lens magnification x objective lens magnification

iii) Give the reasons for each of the following steps when preparing a cross-section of a stem or leaf for examination under the microscope cutting very thin sections

• thin sections allow light to pass through making it easy to observe the tissue **Using a sharp razor blade during the cutting**

- sharp blade does not damage, deform, destroy or distort the surface of cell or tissue
- it makes thin sections

Placing sections in water

- to maintain turgidity hence maintain shape of cell
- it prevents drying of the section

Staining the sections with iodine before observing

- To make chloroplasts, starch containing structures, granules or plastids distinct.

e) i) List the parts of a cell that can be seen under a light microscope a

- a cell membrane
- b cytoplasm c
- cell wall
- e nucleus d
- vacuole

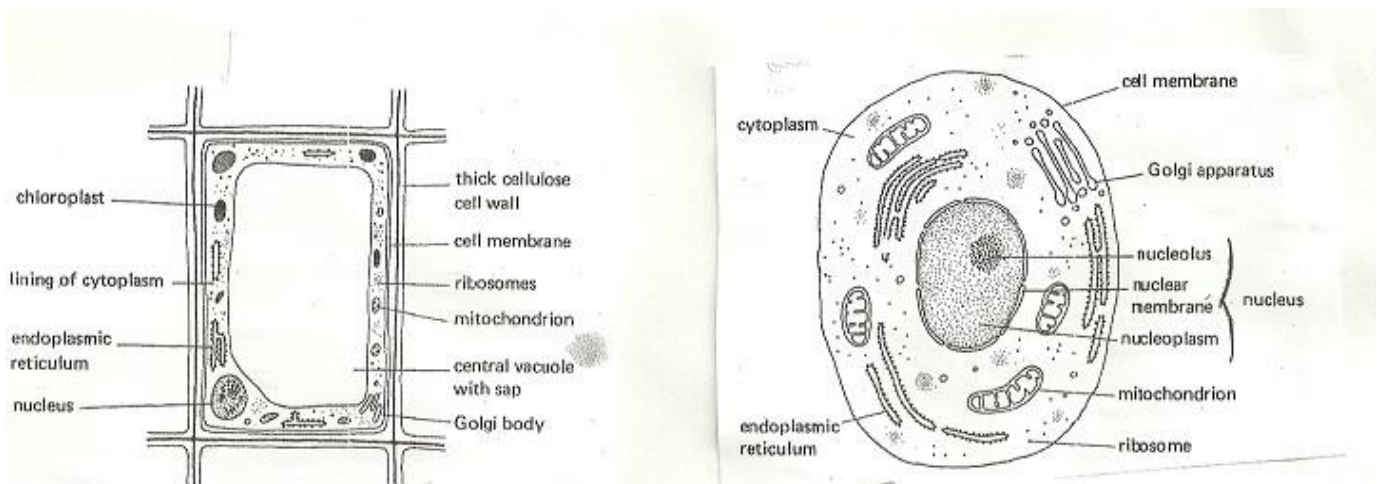

ii) Draw the general structure of a plant and animal cell

iii) List the parts of a cell that can be seen under an electronic microscope and state the functions of each part.

Cell wall

- found in plant cells in addition to cell membrane
- made of cellulose which makes the plant tough
- allows gases, water and other substances to pass through **Cell**

membrane

- permeable/selective to control movement of materials in and out of cells

- bound/encloses the cell contents
- also called plasma membrane or plasmallema

Cytoplasm

- fluid medium where chemical reactions occur
- also where cell organelles are suspended

Nucleus

- controls cell activities

Nucleolus

- synthesizes DNA

Vacuole

- sacs filled with fluid called cell sap
- large in plants but small in animals
- act as reservoirs for food and harmful wastes which would otherwise interfere with the metabolism in cytoplasm

Lysosomes

- store hydrolytic enzymes
- Destroy worn out cell organelles, cells, pathogens
- digestion of food in unicellular organisms
- autolysis

Golgi apparatus

- processing/packaging of synthesized materials
- transporting/secretion of packaged materials/cell materials e.g. glycoproteins and mucus
- production of lysosomes

Ribosomes

- where protein synthesis takes place

Mitochondrion

- synthesis of ATP/energy

Chloroplasts

- where photosynthesis takes place

Endoplasmic reticulum

- transport of cell secretions
- can be rough or smooth

iv) State the functions of cell sap

- stores chemical substances, sugar, salts
- maintains shape of the cell/provides mechanical strength
- plays a role in osmoregulation by creating an osmotic gradient that brings about movement of water

e) Compare plant and animal cells

- plant cells have chloroplasts lacking in animals
- animal cells have many small vacuoles while plant cells have a large central vacuole
- plant cells have cellulose cell walls lacking in animal cells
- cytoplasm in plant cell is in the periphery but in animal cell it is centrally placed
- plants store starch, oil and protein while animals store fats and glycogen
- animal cells have centrioles which plant cells do not have

f) Explain the meaning of each of the following

i) Cell

- Basic unit of organization in an organism
- Specialized animal cells include sperm, ovum muscle
- Specialized plant cells include epidermal, guard cell and palisade cell

ii) Tissue

- these are cells of a particular type grouped together to perform a certain function
- animal tissues include epithelium, blood, nerves, muscle, skeletal and connective tissues
- plant tissues include epidermal, photosynthetic, vascular, strengthening tissues

iii) Organ

- tissues combine together to form organs
- an organ is a complex structure with a particular function
- Animal examples include heart, liver, kidney, lungs, brain, blood vessels, muscles, skeleton
- Plant organs include leaves, roots, flowers, and stem.

iv) Organ system

- organs are grouped together to form systems also called organ systems
- animal systems include excretory, digestive, respiratory, nervous, circulatory, endocrine(hormones/glands), skeletal systems
- plant systems include transport system

g) i) Name the structures which are present in plant cells but absent in animal cells

- Chloroplast
- Cell wall

ii) Name the structures which are present in animal cells but absent in plant cells

- Lysosomes
- Centrioles
- Pinocytic vesicles

h) Explain how to estimate cell size

i) Materials

- cell sizes are measured in units known as micrometers (my)
- required is a transparent ruler marked in millimeters
- $1\text{m}\mu = \frac{1\text{mm}}{1000}$

ii) Procedure

- Click to low power
- place transparent ruler with its millimeter marks on the stage
- focus so that the millimeter marks can be seen as thick dark lines
- estimate the diameter of field of view by counting the one millimeter spaces between the first mark and the last one across the field of view as shown below

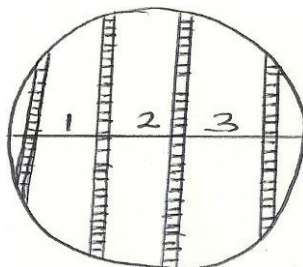

- the diameter of the field of view above is estimated as 3.2 mm
- convert the diameter of the field of view from millimeters to micrometers i.e. $3.2/1000$
- Estimate the fraction of the field of view occupied by the cell. This is done by estimating the number of cells placed end to end that would fill the diameter of the field of view as shown

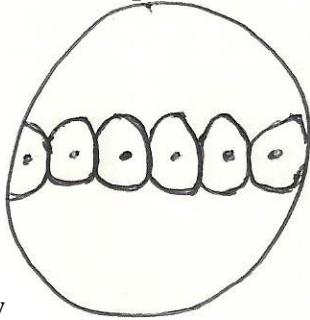

below

- in the figure above, it is estimated that approximately six cells will occupy the diameter of the field of view
- therefore, one cell will occupy $1/6$ of the field of view
- its diameter is calculated as $1/6$ times the diameter of the field of view

i) In a drawing of a giraffe, the height of the head from the ground was recorded as 10cm. the drawing also showed a magnification of 0.02. calculate the actual height of the giraffe

Drawing height = 10cm = 500cm

Magnification 0.02

ii) In a class experiment to estimate sizes of cells a student observed and obtained millimeter marks on the field of view of a microscope as shown in the diagram below.

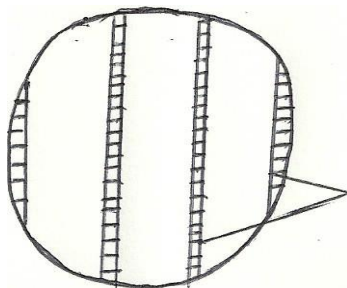

Millimeter marks

- If the student counted 40 cells on the diameter of the field of view, what was the approximate size of the each cell in micrometers?

Diameter of field of view = $3 \times 1000 = 75 \mu\text{m}$

Number of cells 40

iii) Under which of the following light microscope magnifications would one see a larger part of the specimen? X40 or x400? Give a reason

- x40
- Smaller magnification gives a wider field of view hence a larger part seen. e.) a) i)

Define cell physiology

- the study of the functions of a cell in relation to their structure

ii) State the functions of the cell

- exchange of materials between the cell and the external environment

- physiological reactions e.g. photosynthesis
- production of energy through mitochondria

b) i) Describe the structure of cell membrane

- made up of three layers
 - Lipid portion sandwiched between two protein layers
 - Lipid portion enhances penetration of oil soluble substances
- Pores present to facilitate inward and outward movement of water soluble substances

iii) Give the properties of cell membrane

- semi-permeable
- sensitive to changes in temperature and pH
- Possesses electric charges.

c) i) What is diffusion?

- movement of substances/molecules/particles/ions from a region of high concentration to a region of low concentration (until equilibrium is reached)

iv) State the factors affecting diffusion

- diffusion gradient/concentration gradient
- surface area to volume ratio
- temperature
- size of molecules
- state of the diffusing substance
- thickness of membrane and tissues

iii) Explain the roles of diffusion in living organisms

- gaseous exchange
- absorption of digested food in intestines
- movement of salts in plants
- movement of materials between blood capillaries and tissues
- removal of waste materials from bodies of small organisms
- air movement in intercellular spaces in plants

v) Suggest an experiment to demonstrate diffusion

- to a beaker of water, drop crystals of potassium permanganate or copper sulphate
- leave to stand in a place without disturbing
- observe the spreading of molecules
- liquid is coloured uniformly due to diffusion

d) i) What is osmosis?

- Movement of water or solvent molecules from a dilute/hypotonic solution to a more concentrated/hypertonic solution across a semi-permeable membrane.

OR

- movement of solvent molecules from a region of their higher concentration to a region of their lower concentration through a semi-permeable membrane

ii) State the factors affecting osmosis

- concentration of the solution
- concentration gradient
- temperature

iv) Explain the roles of osmosis in living organisms

- helps to draw water into roots of plants
- Helps in the passage of water from one living cell to another in the plant
- helps to keep plant cells turgid increasing support
- Helps in opening and closing of stomata.
- Folding of leaves in **Mimosa pudica** when touched
- Feeding in insectivorous plants

vi) A group of students set up an experiment to investigate a certain physiological process. The set up is as shown in the diagram below.

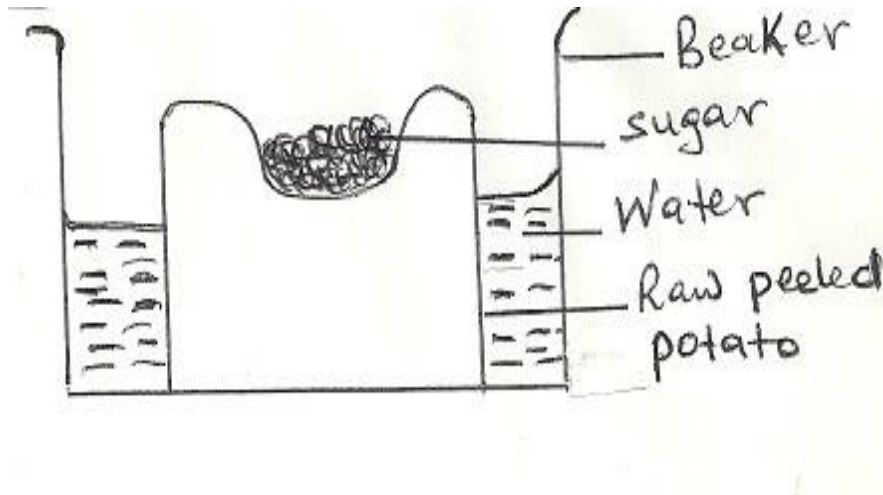

After some time they observed that the level of sugar had risen. What was the physiological process under investigation?

- Osmosis

Why was there a rise in the level of sugar solution?

- sugar solution is more concentrated than cell sap osmosis
- those cells become more concentrated and therefore draw water from neighbouring cells
- this process continues until the cells in contact with the water in the container draw it up causing a rise in the level of the sugar solution

Suggest the results that the students would obtain if they repeated the experiment using cooked potato

- The level of sugar solution will not rise. **What**

is the reason for your suggestion?

- boiling kills/destroys cells making them osmotically inactive

vii) Explain the following terms

Hypotonic

- a solution whose concentration is lower than that of the cell **Isotonic**
- a solution whose concentration is the same as that of the cell

Hypertonic

- a solution whose concentration is higher than that of the cell **Turgor**

pressure

- As a cell gains water, its vacuole enlarges and exerts an outward pressure called turgor pressure.

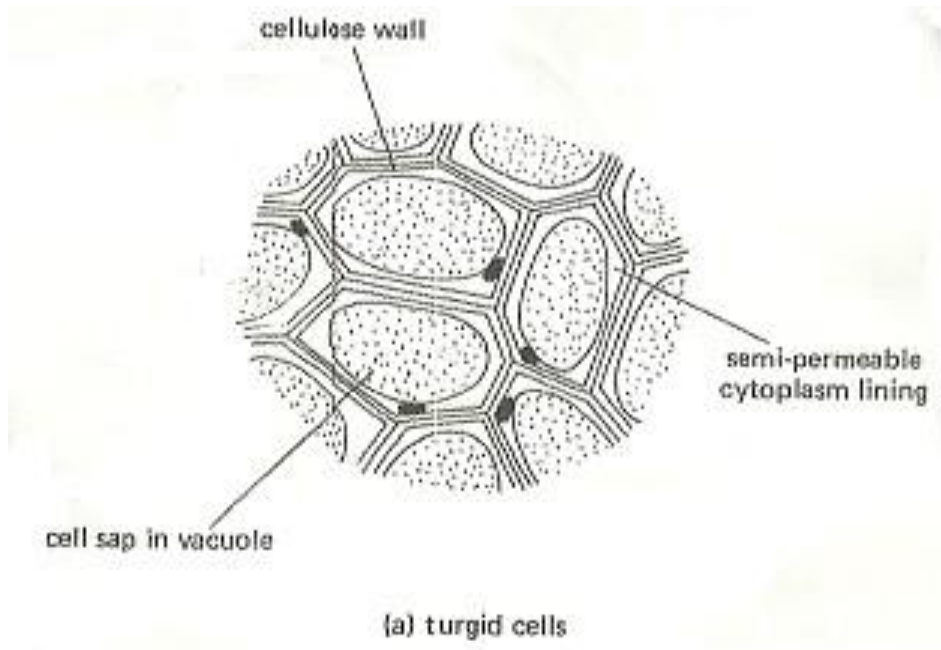

Plasmolysis

- if a plant is placed in a hypotonic solution it loses water
- the protoplasm shrinks to an extent that it pulls away from the cellulose cell wall

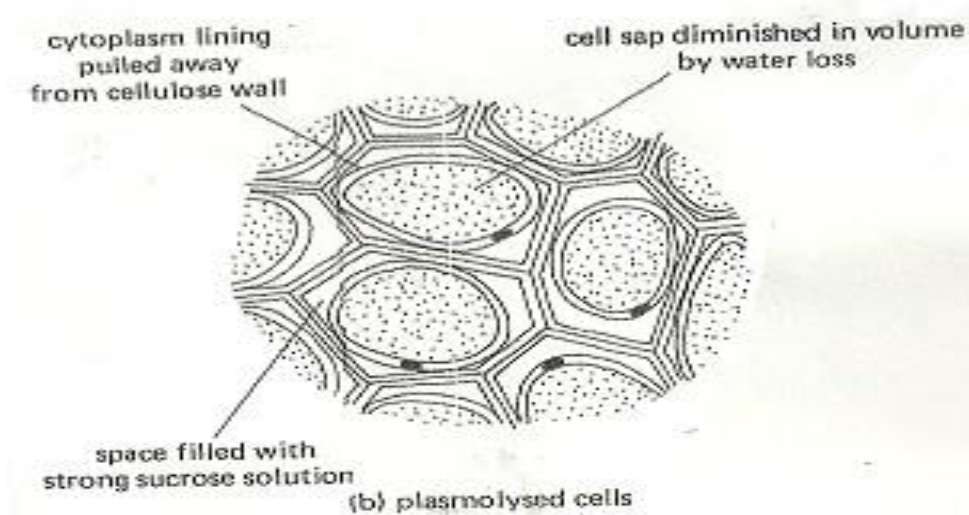

Wilting

- when a plant is turgid it can stand upright
- however, if the cells lose a lot of water, turgidity is reduced
- the plant then droops because the cells are flaccid
- the plant is said to wilt

Haemolysis

- if red blood cells are placed in distilled water, the cells take up water by osmosis, swell and burst
- this is because it does not have any mechanism like the cellulose cell wall to prevent overstretching nor any means of removing excess water
- this is called haemolysis

e) A form one student placed red blood cells in different salt concentrations and obtained the following results:-

There was a gain (+) no change (0 zero) and a loss (-) in the volume of the cells as show below:

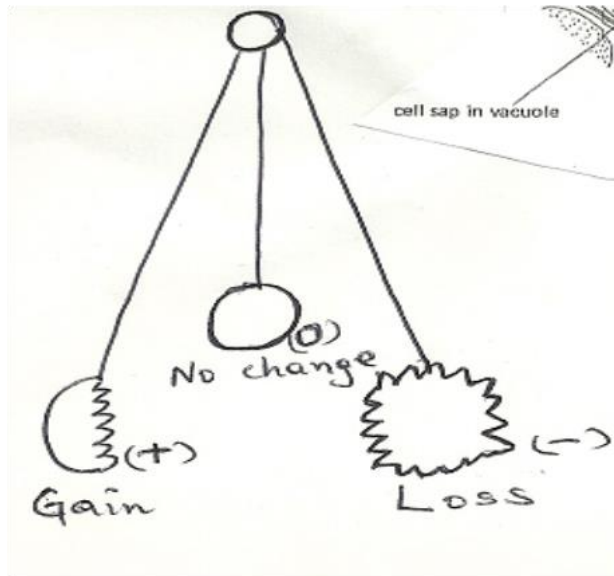

Briefly explain the results of the experiment

- in the first solution, red blood cell absorbed water by osmosis, swell and burst (haemolysis) hence the solution is hypotonic
- in the second solution, there was no change in size or structure as it was isotonic hence no osmotic gradient
- in the third solution the red blood cell lost water to shrink hence became crenated as the solution was hypotonic to the cell cytoplasm.

f) i) What is active transport?

- movement of molecules and ions against a concentration gradient
- the substances move from a lower to a higher concentration gradient by use of energy

ii) State the factors affecting active transport

- oxygen concentration
- temperature
- change in pH
- glucose concentration
- enzyme inhibitors

iii) Why is oxygen important in the process of active transport?

- Oxygen is required for respiration, which produces energy necessary for the process to occur.

2.0) the factors that affect the rates of the following process in living organisms. a.) DIFFUSION.

- **Diffusion gradient** which refers to the difference in concentration of molecules between the region of high concentration and the region of low concentration. Increasing the concentration

gradient causes an increase in rate of diffusion and vice versa.

-Surface area to volume ratio .is the ratio of total surface area exposed by an organism compared to its body volume. Small sized living organisms have a large surface area to

Volume ratio. The larger the surface area to volume ratio, the higher the rate of diffusion and vice versa.

Small organisms like amoeba and paramecium can hence rely on diffusion for transport of substances into and within its body and removal of waste products

-thickness of membranes. Molecules take longer to diffuse across thick membranes than across thin membranes hence the thinner the membrane the higher the rate of diffusion.

-Temperature. Increasing temperature increases the kinetic energy of diffusing molecules making them to spread faster. Increasing temperature increases the rate of diffusion and vice versa

-size of molecules/molecular weight. Small sized molecules/molecules of low molecular weight move/diffuse faster hence the rate of diffusion is high where the molecules involved are small or have low molecular weight and vice versa.

B.) OSMOSIS

-Temperature. Increasing temperature increases the kinetic energy of water molecules making them to spread faster. Increasing temperature increases the rate of osmosis and vice versa

-concentration gradient/diffusion pressure deficit. Refers to the difference in concentration on either side of a semi-permeable membrane. The higher the osmotic pressure difference the higher the rate of osmosis.

C.) ACTIVE TRANSPORT

OXYGEN CONCENTRATION. It is required for respiration/to oxidize respiratory substrates to release energy required for active transport. an increase in oxygen concentration causes a simultaneous increase to the rate of active transport upto a certain level.

P^H Enzymes being protein in nature are P^H specific. Extreme change in P^H affect the rate of respiration which is controlled by enzymes and may denature the enzymes reducing the rate of active transport.

-GLUCOSE CONCENTRATION. is the main respiratory substrate for energy production. An increase in glucose concentration in cells increase the rate of respiration and hence the rate of active transport is increased upto a certain optimum level beyond which any additional increase in glucose concentration has no effect.

TEMPERATURE. The process of respiration by which energy for active transport is generated is controlled by enzymes. Enzymes work best at temperatures of between 35⁰c-40⁰c, usually called optimum temperature ranges. At very low temperatures enzymes are inactive lowering the rate of respiration hence low rates of active transport . increase in temperature above optimum (above 40⁰c)denatures enzymes slowing down respiration and active transport until it finally stops.

ENZYMES INHIBITORS. They are substances which slow down (by competing with the enzyme for the active sites in the substrate) or stop (by blocking the active sites of the enzyme) the activity/functioning of enzymes .this slows down or stops respiration and so is active transport.

CONCENTRATION OF CARRIER MOLECULES IN THE CELL MEMBRANE. They are

substances that bind to the ions being transported actively and carrying them across the membrane. increase in concentration of carrier molecules increases the rate of active transport upto a certain level and vice versa.

4.) Explain briefly the role of osmosis in living tissues. In plants:

Osmosis facilitates the absorption of water from the soil by plant roots, water is required for the process of photosynthesis.

Turgidity of cells contributes to support in herbaceous plants and helps plant to maintain shape. Helps in closing and opening of stomata regulating the process of gaseous exchange and transpiration.

It facilitates feeding in insectivorous plants like venus fly trap. In animals:

Enables reabsorption of water from the kidney tubules back to blood stream facilitating the process of osmoregulation.

It enables organisms in fresh water bodies like amoeba to absorb water. it is applied in food preservation.

5.) explain what happens when plant and animal cells are put in hypotonic and hypertonic solutions.

a. i) plant cells in hypotonic solution.

The concentration of the plant cell sap is hypertonic to the solution/water medium. the cell draws in water by osmosis through the cell wall, cell membrane into the cell cytoplasm. Water enters the cell vacuole by osmosis; it enlarges and exerts an outward pressure on the cell wall called turgor pressure. Increased turgor pressure pushes the cell cytoplasm against the cell wall until the cell wall cannot stretch any further. The cell becomes firm or rigid and is said to be turgid. As the cell wall is being stretched outwards, it develops a resistant inwards pressure that is equal and opposite to the turgor pressure and this is called wall pressure.

ii.) Plant cells in hypertonic solution.

The plant cell sap is hypotonic to the solution medium. Water molecules are drawn out of the plant cells by osmosis into the hypertonic solution through the semi-permeable membrane of the plant cells. As a result the plant cell will start to shrink/less rigid and become flabby. The cell membrane/plasma membrane is pulled away from the cell wall and the cell is said to be flaccid. this process by which a plant cell lose water, shrink and become flaccid is called plasmolysis. However the shape of the plant cell is maintained by the tough rigid cellulose cell wall which prevents crenation in plant cells.

b.i) Animal cells in hypotonic solution.

The concentration of water in the cytoplasm of the plant cells is hypertonic to the solution medium in the test. Water molecules are then drawn into the animal cell cytoplasm from the surrounding medium by osmosis through the semipermeable membrane. the cell swells as water is drawn into them by osmosis .as water continues

to enter into the cell, the weak animal cell membrane bursts a process called lysis. In red blood cells this process is called haemolysis. However in unicellular organisms like amoeba and paramecium, bursting of their cells does not take place because they have specialized organelles called contractile vacuoles for removal of excess water out of their bodies/cells.

ii.) Animal cells in hypertonic solution.

The concentration of the animal cells cell cytoplasm is hypotonic to the solution medium in the test. The surrounding hypertonic solution will draw water out of the animal cells by osmosis through the semi-permeable membrane. Continued loss of water causes the cells to be smaller in size and their membranes become wrinkled. This process will continue until the concentration of the cell sap and the surrounding medium is equal i.e isotonic. The process by which animal cells lose water and shrink is called crenation.

6.) Explain briefly the role of active transport in living organisms.

It is involved in active reabsorption of glucose and mineral salts in kidney tubules during formation of urine. It enables the absorption of digested food from the alimentary canal/small intestines into the blood stream. Excretion of waste products from body cells for eventual removal. Involved in transmission of nerve impulses within the nerve cells through the sodium pump which maintains a balance between sodium and potassium ions. It facilitates accumulation of substances in the body cells to offset osmotic pressure of organisms in dry and marine environment allowing them to absorb water by osmosis and avoid desiccation. In plants it enables plant roots to absorb water from the soil against the concentration gradient. It's involved in translocation of manufactured food in the phloem tissue within the plant body. It's involved in the opening and closing of the stomata through the sodium-potassium pump mechanism.

iv) Outline the roles of active transport in living organisms

- mineral salt intake by plants
- selective reabsorption of glucose and some salts by kidney tubules
- absorption of digested food by small intestines
- excretion of waste products from body cells
- reabsorption of useful materials in the blood stream or at the tissue fluid
- sodium pump mechanism in the nerve cells/neurons f.) a) i)

Define nutrition

- the process by which living organisms obtain and assimilate nutrients

ii) State the importance of nutrition

- for respiration to get energy
- for growth
- for development
- to repair and replace worn out and damaged parts and tissues

b) Differentiate the various modes of feeding

i) Autotrophism

- manufacturing food from simple organic substances
- types are photosynthesis and chemosynthesis

ii) **Heterotrophism**

- obtaining food from autotrophes and other organic substances
- types are holozoic, saprophytic and parasitic g.) a) i)

Define photosynthesis

- the process by which green plants build up organic compounds from carbon IV oxide and water in the presence of sunlight

ii. State the importance of photosynthesis

- formation of sugars/glucose which is a source of energy
- purification of air(CO₂ is used, O₂ is released)
- storage of energy to be used later in respiration
- stores energy in wood, coal, oil to be used later to run industries

Structural adaptation of the leaf to its function

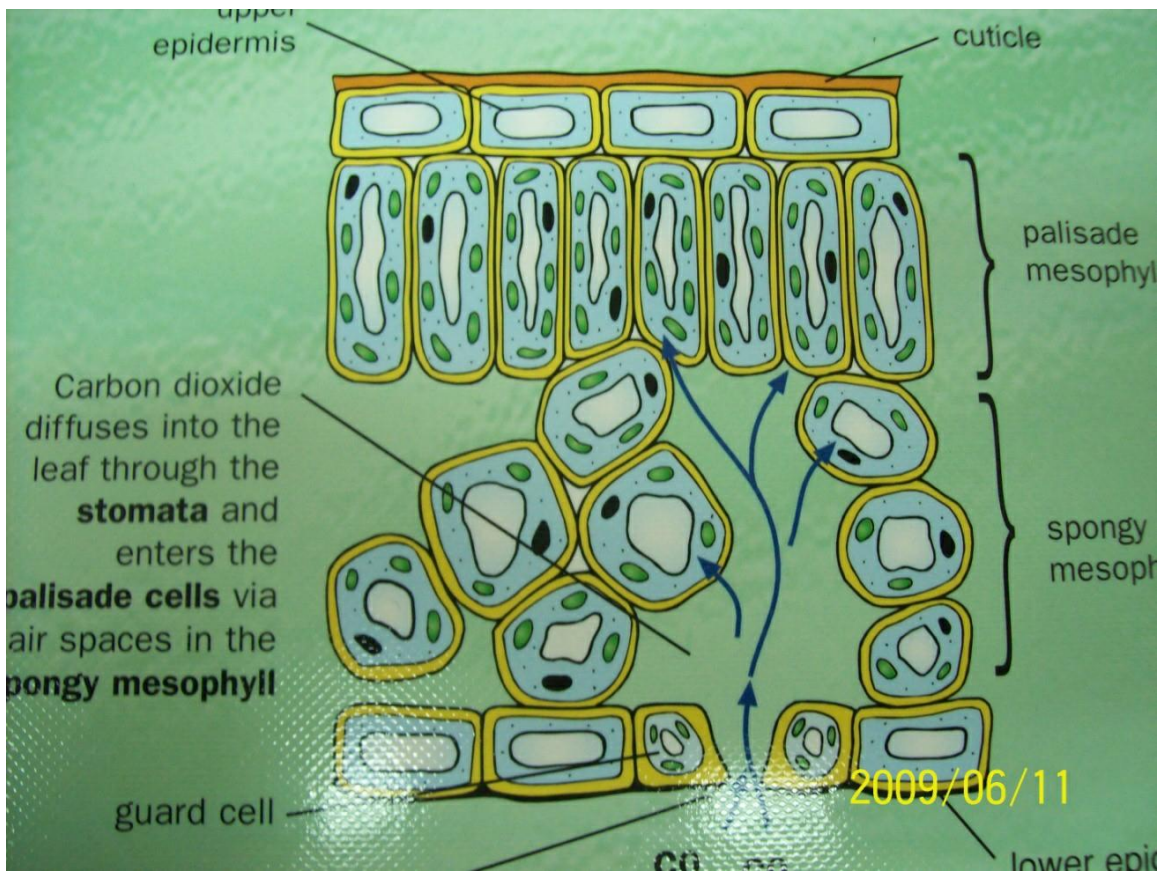

The leaf has a broad and flattened lamina to provide a large surface area for trapping optimum light for photosynthesis and allow maximum gaseous exchange.

The leaf epidermis is thin (one cell thick) to reduce the distance across which diffusion of carbon (iv) oxide gas to palisade cells and oxygen gas from palisade cells takes place. The leaf has numerous stomata that allows easy diffusion of gases into and out of the palisade tissue.

The leaf cuticle and epidermis are transparent to allow easy penetration of light to the photosynthetic tissue.

The palisade cells are numerous, elongated and contain numerous chloroplasts to trapping optimum light for photosynthesis.

The palisade tissue is just beneath the upper epidermis exposing them to trap optimum light for photosynthesis.

The leaf has numerous leaf veins consisting of a.) xylem vessels and tracheids for transporting water and dissolved mineral salts from the soil to the photosynthetic tissue

b.) phloem tissue for translocation of of manufactured food from the leaf to storage organs and other parts of the plant .

Numerous and large air spaces in the spongy mesophyll layer for optimum gaseous exchange with the photosynthetic tissue.

Phyllotaxy which is regular arrangement of leaves on the stem minimizes overshadowing and overlapping exposing all leaves to light for photosynthesis.

The prominent midrib and leaf veins reduces chances of rolling of leaves maintaining a large surface area for trapping optimum light for photosynthesis.

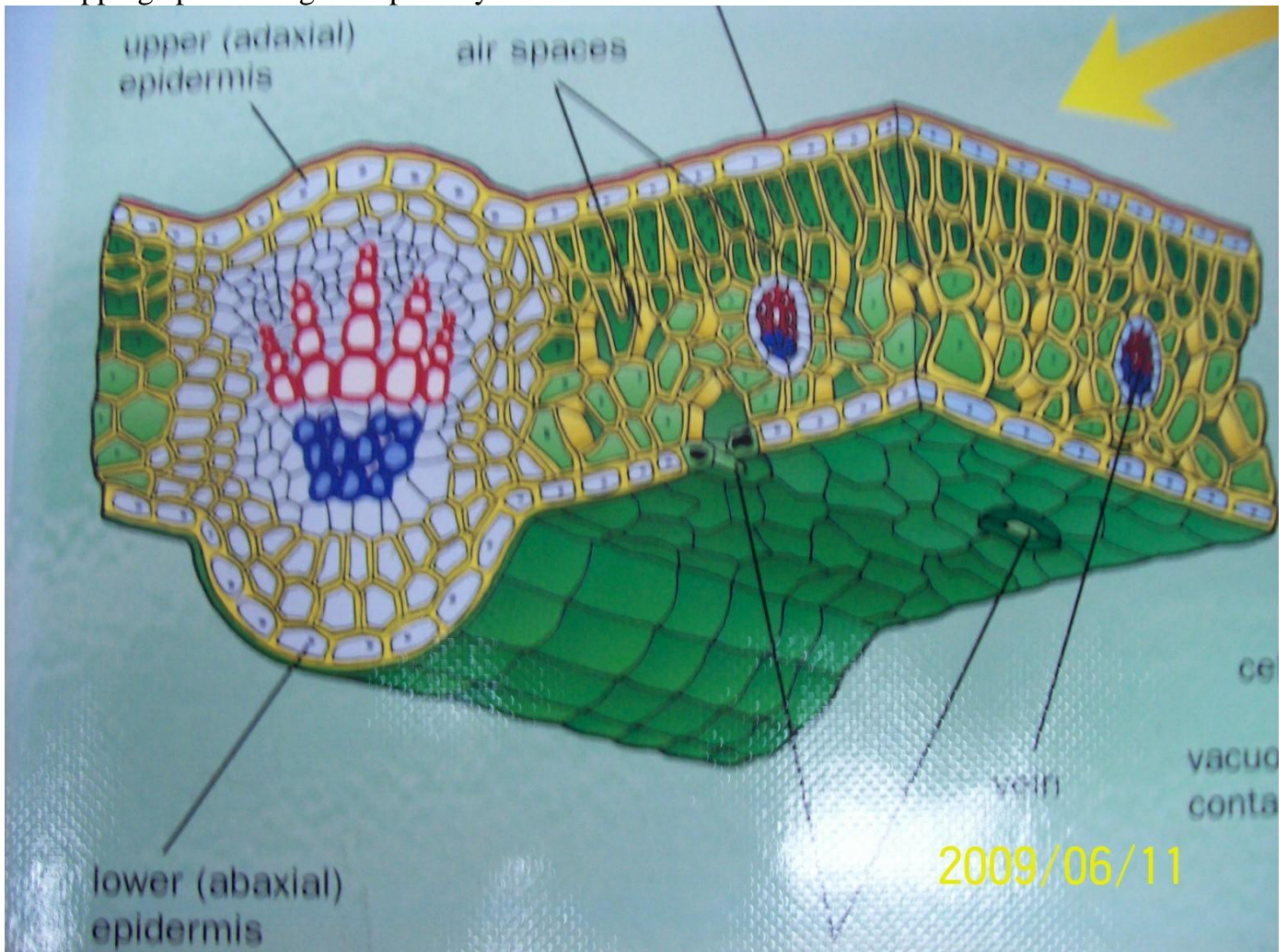

C) Describe the chloroplast

i) Structure

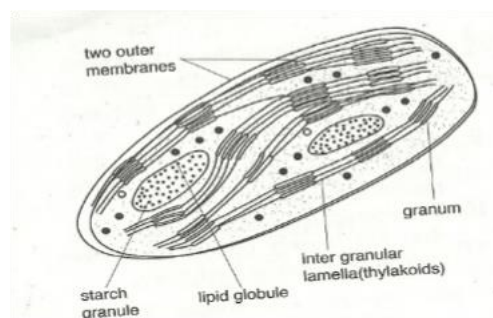

structure and function of

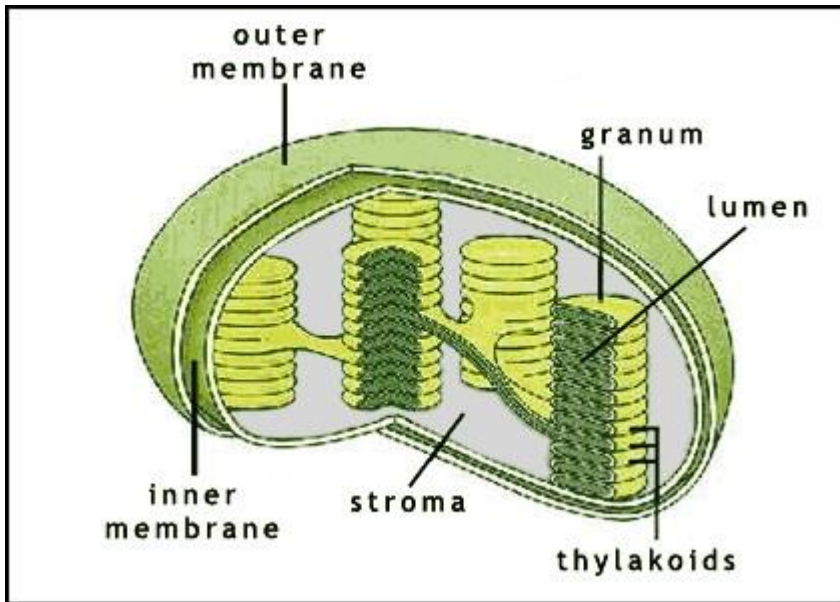

for packing many chlorophyll pigments

ii) Function

- structure in which photosynthesis takes place

iii) Adaptations

- has numerous/many grana to provide large surface area

- have numerous chlorophyll pigments which trap sunlight/light for photosynthesis
- has stroma/third matrix which contain certain enzymes that catalyze photosynthetic reactions

d) i) Give a word equation for photosynthesis

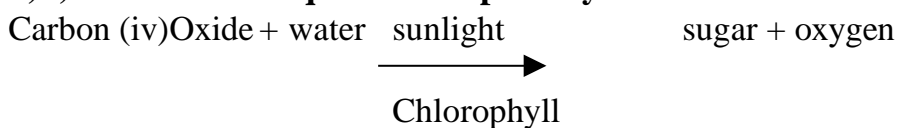

.) Describe briefly the process of photosynthesis in plants.

The process of photosynthesis takes place in green plants allowing them to make their own food. The process is controlled by enzymes and involves a series of reactions that take place in chloroplasts. The raw materials required are water and carbon (iv) oxide.the process takes place in two consecutive stages i.e

Light reaction stage

It's also called the light dependent stage as it requires light energy . the reactions take place in the granna of the chloroplast. light energy from the sun is trapped by chlorophyll in the chloroplast and converted into chemical energy. This energy splits water molecules into hydrogen ions and oxygen atoms a process is called photolysis. The oxygen atoms are released as aby product or used up in the process of respiration. The hydrogen ions formed are used in the dark stage of photosynthesis.

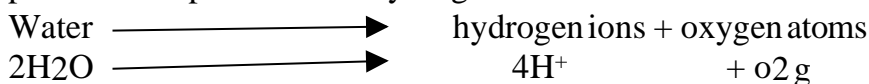

Some of the light enrgy is used to combine a molecule called adenosine Diphosphate(ADP) with a phosphate group to form the rich energy molecules called adenosine Tri-Phosphate(ATP)

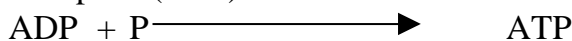

Dark reaction stage

It's also called the light independent stage of photosynthesis since light is not required because it can take place both in presence and absence of light. the reactions are controlled by enzymes. the hydrogen atoms released in the light stage are combined with carbon(iv)oxide to form simple sugars mainly glucose. The process uses energy from ATP. This is reffered to as carbon (iv) oxide fixation. The reactions take place in the stroma of chloroplast. The excess glucose is converted into starch or lipids for storage.

The general process of photosynthesis can be summarized by the following word and chemical equitions.

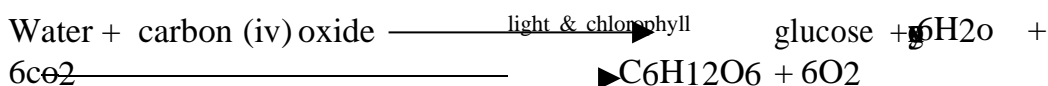

9.) Factors that cause high rate of photosynthesis.

High water availability in the soil. Water a raw material for photosynthesis is split in presence of light

to provide the hydrogen ions required in carbon (iv) fixation. When water is readily available more hydrogen ions are produced hence high rate of photosynthesis.

High light intensity. Light splits water molecules to hydrogen ions and oxygen atoms. Increasing light intensity increases the rate of photosynthesis up to a certain level beyond which other factors become limiting and rate of photosynthesis becomes constant.

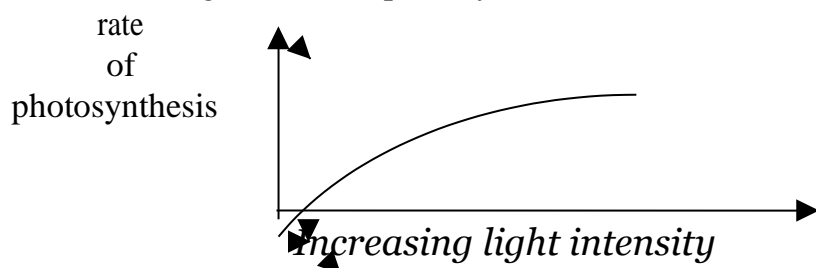

Day length. Long day length especially at high latitudes (temperate regions) provides more light for photosynthesis causing an increase in the rate of photosynthesis.

Light quality. The preferred wavelengths for photosynthesis range between 400nm- 700nm. the rate of photosynthesis is higher in red and blue light and lower in all other types of light.

Concentration of carbon (iv) oxide. It's a raw material required to combine with hydrogen ions to form simple carbohydrate molecules. Increasing the concentration of carbon (iv) oxide increases the rate of photosynthesis up to an optimum level beyond which other factors limit the rate of photosynthesis.

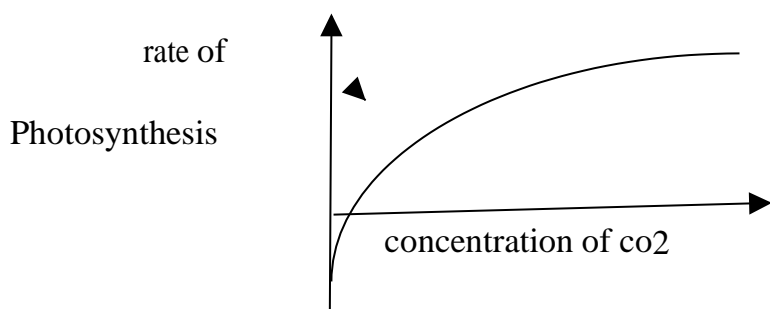

f) Give the differences between the light and dark reactions during photosynthesis

Light reactions	Dark reactions
<ul style="list-style-type: none"> occurs in grana 	<ul style="list-style-type: none"> occurs in stroma

h.) a) i) What are chemicals of life?

- substances which make up cells, tissues and organs of the living system
- they combine to form organic compounds

ii) What are organic compounds?

- compounds that contain the element carbon

iii) List the organic compounds

- proteins
- carbohydrates
- lipids(fats and oils)
- vitamins
- enzymes
- nucleic acids(DNA and RNA)

b) i) What are carbohydrates?

- Compounds of carbon, hydrogen and oxygen
- The elements are in the ratio of 1 carbon: 2 hydrogen: 1 oxygen

ii) Name the groups of carbohydrates

- monosaccharides (simple carbohydrates) e.g. glucose, fructose and galactose
- disaccharides (formed when two monosaccharides combine) e.g. maltose, sucrose, lactose
- polysaccharides (composed of many monosaccharides and disaccharides) e.g. starch, glycogen, cellulose

iv) State the general functions of carbohydrates

- production of chemical energy
- storage of starch(plants) and glycogen (animals)
- commercial uses e.g. manufacture of paper, textiles

c) i) what are proteins?

- compounds of carbon, hydrogen and oxygen and in addition nitrogen, and sometimes sulphur and or phosphorus
- building blocks are called amino acids

ii) Name the types of amino acids

- essential amino acids which must be supplied in food since they body cannot synthesize them
- Non-essential amino acids which body can synthesize.

iv) State the classes of proteins

- first class proteins which supply all the essential amino acids
- second class proteins which lack at least one amino acid

v) Give the functions of proteins

- structural compounds e.g. muscles, hair, hooves, and feathers
- as enzymes e.g. pepsin, trypsin
- hormones e.g. insulin and glucagons
- antibodies
- part of haemoglobin molecule
- actin and myosin in muscles
- collagen in bones and cartilage
- pigments in rods and cones for coordination
- components of blood i.e. plasma proteins **d) i)**

What are lipids

- Fats and oils

- They contain carbon, hydrogen and oxygen

- However, they contain a higher proportion of carbon and hydrogen but less oxygen than in carbohydrates

ii) Name the types of lipids

- oils (liquid under room temperature)
- fats (solid under room temperature)

iii) What are the building blocks of lipids?

- fatty acids and glycerol

v) State the functions of lipids

- production of energy
- source of metabolic water
- structural compound

e) i) What are enzymes?

- a chemical compound, protein in nature, which acts as a biological catalyst

ii) State the properties of enzymes

- are highly specific in nature
- they are not used up during chemical reactions
- work within specific range of temperature
- work within specific range of pH
- enzyme controlled reactions are reversible

iii) State the factors that affect enzyme action

- temperature
- substrate concentration
- pH of the medium
- enzyme concentration
- presence of inhibitors and co-factors

v) Name the types of enzyme inhibitors

- competitive inhibitors

- non- competitive inhibitors

vi) What are the functions of enzymes?

- enable cellular reactions to take place at a reasonably faster rate
- Control cell reactions therefore no violent incidences occur in cells that might burn them.

i.) a) Explain the various types of heterotrophic nutrition

i) Holozoic

- Mode of feeding by animals where solid complex food substances are ingested, digested and egested.

ii) Saprophytism

- feeding on dead organic matter

iii) Parasitism

- feeding from another organism but not killing it

iv) Symbiosis

- an association in which organisms of different species derive mutual benefit from one another

b) Differentiate between omnivorous, carnivorous and herbivorous modes of nutrition

i) Herbivorous

- herbivores feed exclusively on vegetation

ii) Omnivorous

- omnivores are animals which feed partially on plant materials and partially on flesh e.g pigs

iii) Carnivorous

- Carnivores feed on flesh alone e.g. lion

c) i) What is dentition?

- Refers to the number, arrangement and kind of teeth in an animal

ii) Distinguish between the terms homodont and heterodont

- homodont have same kind ,type, shape and size of teeth which perform similar function e.g. fish, reptiles and amphibians
- Heterodont have different kind, type, shape and size of teeth which perform different functions as those found in mammals.

iv) Name the types of teeth found in mammals

- Incisors
- Canines
- Pre-molars
- Molars

d) Describe the adaptations and functions of various types of mammalian teeth

Incisors

- chisel shaped/wedge shaped
- found in the front of the buccal
- used for cutting

i) Canines

- next to incisors

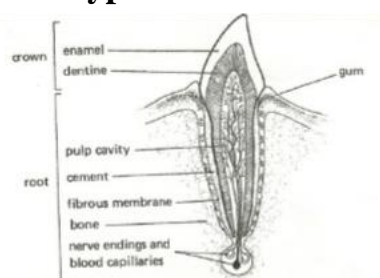

cavity

- very sharp and pointed
- located at the sides of jaws
- used for tearing food

ii) Premolars

- next to canines but before molars
- have cusps and ridges on their
- used for crushing and grinding

iii) Molars

- found at the back of the jaw
- have cusps and ridges on their surface
- absent in young mammals but appear later when permanent teeth grow
- used for grinding and crushing

□

e) i) Draw a labeled diagram to represent internal structure of a mammalian tooth.

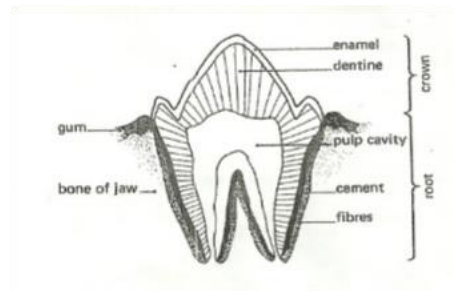

surface

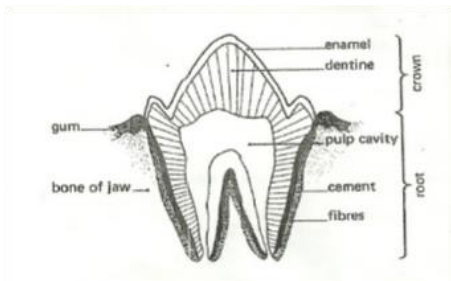

ii) State the functions of the labeled structures labeled Dentine

- main constituent of teeth
- like bone in structure but contains no cells

Enamel

- protects tooth from mechanical/physical injury
- the hard covering of the exposed part of teeth **Crown**
- portion of tooth above the gum
- covered with dentine

Root

- part imbedded in the jaw below the gum
- covered by substances called cement
- cement is hard and bone-like

Cement

- bone-like substance covering root and enamel of mammalian tooth **Neck**
- region at the same level with the gum
- forms a junction between the crown and root
- covered by enamel

Pulp cavity

- at centre of tooth within dentine
- has blood vessels for transporting nutrients/food and gases
- has nerves for sensitivity

f) i) What is dental formula?

- formula indicating the number of each kind of teeth for a given species of mammal
- only half the jaw is included
- the number in the upper jaw of one side is written above that in the lower jaw of one side
- the categories of teeth are given in the order incisors, canines, pre-molars, molars

ii) Give examples of dentition in named mammals

- carnivore e.g. dog $i^{2/3}, c^1, pm^{2/3}, m^{2/3} = 42$
- herbivore e.g. sheep $I^0, c^0, pm^{2/3}, m^{3/3} = 30$
- Omnivore e.g. human $I^{2/2}, c^1, pm^{2/2}, m^{3/3} = 32$

iii) How would one use dental formula to identify the following?

Herbivores

- presence of diastema/gap between incisors and premolars
- free movement of tongue
- absence of incisors in upper jaw
- absence of canines

- closely

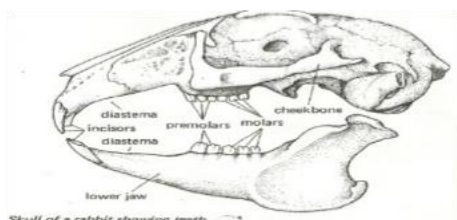

- presence of hard pad packed molars

Carnivore

- presence of canines
- presence of carnassial teeth
- presence of incisors in upper jaw/absence of diastema/gap between incisor and premolar

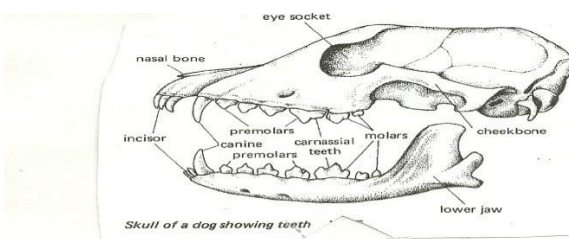

iv) State the functions of the following structures in mammals

Carnassials

- tearing flesh from bones

Pad of gum

- provides grasping surface for lower incisors

g) Name the common dental diseases

- dental caries
- periodontal (pyorrhea and gingivitis) **j.) a) i)**

What is digestion?

- breakdown of complex food particles by enzymes to simple substances which can be absorbed

ii) Explain the types of digestion

Intercellular

- Digestion that takes place in food vacuoles inside cells. **Extra**

cellular

- digestion that takes place outside cells e.g. in the digestive tract

b) i) Draw human digestive system

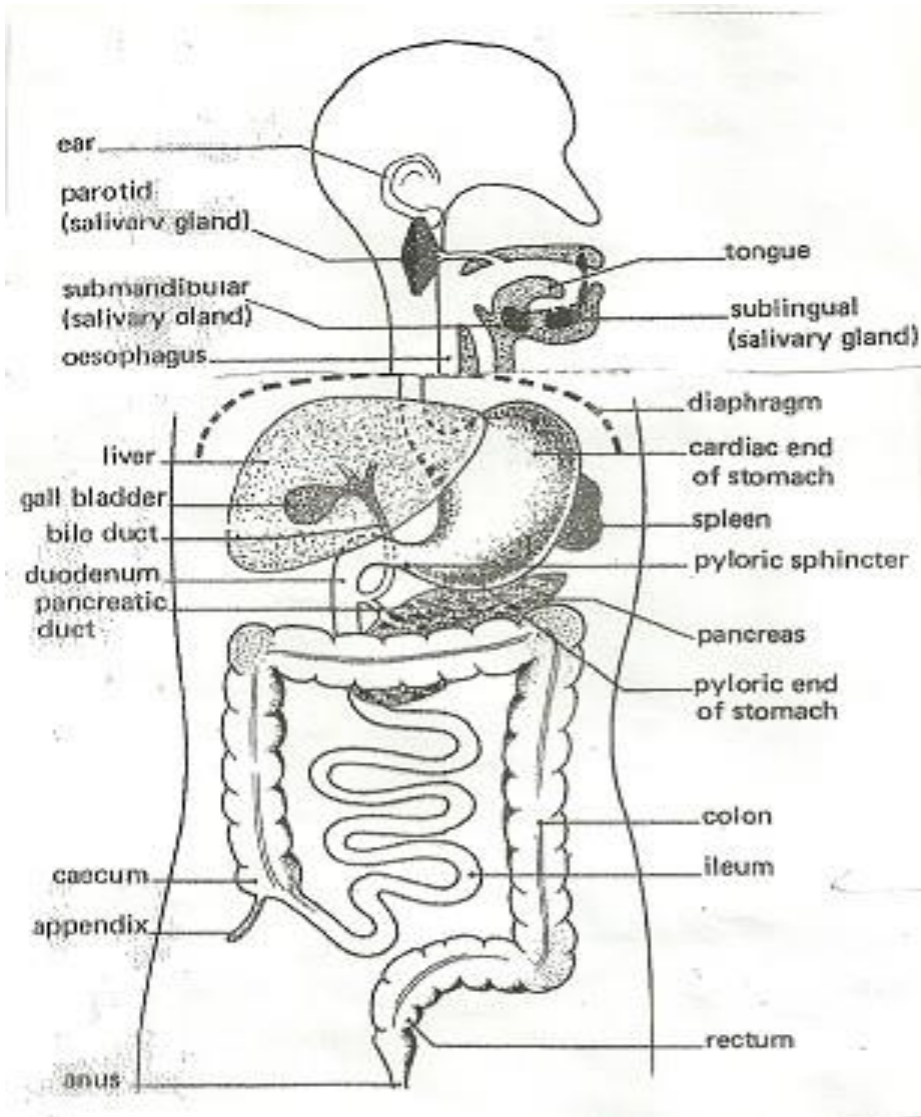

ii) Describe the process of digestion in the various parts of the human digestive system

Mouth

- contains teeth for chewing
- has tongue for mixing food with saliva
- has salivary glands for chemical digestion, secretion of enzymes and mucus secretion
- starch is acted on by salivary amylase enzymes to produce maltose
- the tongue rolls food into a bolus which is carried into the stomach by peristalsis
- peristalsis is movement of food along the gut by waves of contraction
- it facilitates rapid digestion due to its mixing action

Oesophagus

- also called gullet
- forms a passage for food by peristalsis
- connects the mouth to the stomach

Stomach

- has gastric glands which secrete gastric juices
- these juices contain hydrochloric acid (HCL), mucus, and the enzymes pepsin, rennin and lipase
- HCL produces an acidic medium for enzyme action
- Proteins are acted upon by pepsin to produce peptides
- Caseinogen is acted upon by rennin to produce casein
- Fats are acted upon by lipase to produce fatty acids and glycerol
- Mucus lubricates the stomach and prevents autolysis of stomach (mucus protects stomach)

Duodenum

- the first u-shaped part of the small intestine
- food in the stomach is now in a semi-liquid form called chyme
- chyme leaves the stomach by peristalsis into the duodenum
- there, the liver produces bile pigments, bile salts and sodium hydrogen carbonate
- the stomach is usually alkaline to neutralize chyme which is acidic
- bile salts emulsify fats
- bile comes from the gall bladder through the bile duct
- sodium hydrogen carbonate provides the correct pH/alkaline
- pancreatic juices are released by pancreas into the duodenum
- the juices contain trypsin, chymotrypsin, amylase, lipase and protease
- proteins are acted upon by trypsin to form polypeptides and amino acids
- starch is broken down to maltose by amylase

- produces intestinal juices

- Intestinal juice contains maltase, sucrase, lactase, erepsin, lipase, and several other peptidases

- Maltose is broken down to glucose and galactose by lactase
- Sucrose is acted upon by sucrase to glucose

Polypeptides are broken down into amino acids by erepsin

- Mucus secretion is to protect the ileum wall from digestion/autolysis **Colon**
- Commonly called the large intestine
- Wider than the ileum
- has several mucus-producing cells

Highly folded for water absorption

- Also prepares food for egestion
- egestion is the process by which the insoluble parts of food are discharged from the body in form of faeces.

Rectum

- Muscular and enlarged
- it produces mucus
- used for storage and removal of faeces **Anus**
- found at the exterior end of the rectum The rectum opens into the anus
- The anus has anal sphincter to control egestion
- Anus is used for egestion of faeces

c) Explain how mammalian intestines are adapted to perform their function

- The mammalian intestines are relatively long and coiled. This allows food enough time and increases surface area for digestion and absorption of products of digestion
- The intestinal lumen (inner wall) has projections called villi to increase surface area for absorption
- The villi have projections called micro-villi which lead to further increase of surface area for absorption
- The walls have glands which secrete enzymes for digestion e.g. maltase, sucrase, lactase, peptidase and enterokinase.
- Goblet cells (mucus secreting cells or glands) produce mucus which protects the intestinal wall from being digested and reduces friction.
- Intestines have openings of ducts which allow bile, a pancreatic juice into the lumen
- The intestines have circular and longitudinal muscles whose contraction and relaxation (peristalsis) leads to mixing of food with enzymes (juices) helps push food along the gut.
- The intestines are well supplied with blood vessels that supply oxygen and remove digested food.
- Intestines have lacteal vessels for transport of lipids (fats and oils)
- Intestines have thin epithelium to facilitate fast/rapid absorption/diffusion

d) What is the function of hydrochloric acid in digestion?

- kills bacteria
- activates trypsinogen to trypsin which digests proteins to peptones and peptones to soluble amino acids

- provides acidic medium for gastric enzymes

e) i) What is assimilation?

- The process by which digested food is taken up by cells and used in the body for various purposes.

ii) State the uses of digested food in the bodies of animals

- Protection
- Repair
- Growth
- Energy production

f) Name the types of food substances in the food that do not undergo digestion in human digestive system

- mineral salts
- water
- roughage
- vitamins

k.) Explain the importance of the following food substances in human nutrition

Vitamins

- are organic chemical compounds essential for a healthy body
- are obtained from fresh fruits and vegetables
- some are synthesized in the body e.g. vitamin K
- they are destroyed by overcooking food
- they protect the body against diseases, play regulatory mechanisms in the body and act as co-enzymes
- insufficient amounts lead to deficiency diseases e.g. rickets, scurvy, beriberi

a) Mineral salts

- are important in organic compounds containing elements which are essential for normal body metabolism
- those required in large quantities are called macro-nutrients while those required in small quantities are called micro-nutrients or trace elements
- They are used in bone and teeth formation. In osmotic balance and neurotransmission
- insufficient amounts lead to anaemia, rickets, goiter
- Excess amounts lead to high blood pressure, and dental disorders.

b) Roughage

- composed of cellulose and plant fibers
- digested by cellulose contained by gut microorganisms
- provides grip essential for peristalsis
- lack of roughage leads to slow movement of food leading to constipation
- roughage adds bulk to food for peristalsis to take place

c) Water

- used in transport in the body, universal solvent, hydrolysis
- insufficient leads to dehydration

l.) Explain the factors that determine energy requirements in humans

a) Basal Metabolic Rate (BMR)

- this is the energy required when the body is completely at rest
- used to carry out breathing, heartbeat, circulation of blood and other basic reactions
- also used in maintaining body temperature at constant
- all movements or physical work e.g. walking, eating required more energy.

b) Occupation

- means activity occurring everyday
- everyday activity determines energy requirement
- People doing heavy work like digging require more energy than office workers.

c) Age

- children carry out many activities and also have more cell division than adults
- their BMR is therefore higher than for adults
- as they grow older, they become less active and their energy requirements decrease

d) Body size

- small bodied people have a large surface area to volume ratio
- their bodies lose more heat energy to the surrounding
- they therefore require more energy-giving foods
- this is the opposite for big bodied people

e) Sex

- most males are more muscular than females
- they also do heavier work than females hence require more energy
- females do lighter work hence require less energy

f) Climate

- in warm climate the body requires less energy
- in low temperatures the body requires more energy to maintain body temperature

m.) Explain various tests carried out on food

Test	Procedure	Observation	Conclusion
Starch	- add iodine solution	- colour changes to blue black/dark blue	Present
Reducing sugar	Benedicts solution heat/boil/warm in hot water bath	- colour changes to Green to yellow to orange to brown to red	Present
Non-reducing sugar	Dilute HCL, NaHCO ₃ , heat/boil, warm in hot water	- colour changes to Green to yellow to orange to brown to red	Present

	bath		
Proteins	1% CuSO ₄ , 5% NaOH	-- colour changes to purple/violet	Present
Ascorbic acid (Vitamin C)	DCPIP drop wise	DCPIP decolorized	Present
Fats/oils (lipids)	- rub on filter paper - ethanol	- translucent mark - white emulsions	present

mwalimupublishers@gmail.com

**Updated CPA,ICT,KASNEB,High School &Primary School
Notes 0707550000/0705525657**