

# INTRODUCTION TO AGRICULTURE

## K.C.S.E PAST PAPERS

1. What is plantation farming system?
2. State the main characteristics of shifting cultivation.
3. Differentiate between olericulture and pomoculture
4. State three characteristics of shifting cultivation.
5. State six reasons why agriculture is important in Kenya's economy
6. State two ways in which agriculture contributes directly  
to the development of industries.
7. Give the limitations of pastoral Farming.
8. State any two disadvantages of pastoral nomadism system of farming.

## FACTORS INFLUENCING AGRICULTURE

### K.C.S.E PAST PAPERS

1. List four environmental factors that affect crop distribution in Kenya.
2. State two ways by which wind affects the growth of crops.
3.
  - a) State two ways by which wind affects the growth of crops.
  - b) Give two roles of micro-organisms in the soil that are beneficial to crops
  - c) State three properties of soil that are influenced by its texture.
4. List down the four aspects of rainfall that affect agriculture.
5. Describe the environmental conditions that may lead to low crop yields.
6. Outline three effects of soil organisms which benefit crop growth.
7. State two causes of hard pan in a crop yield.
8.
  - a) Name two processes of rock weathering.
  - b) Differentiate between soil texture and soil structure.
  - c) State three benefits of good soil structure in crop production.
9.
  - a) List two aspects of light that influence crop growth.
  - b) The diagram below shows an experiment set up using soil types G, H and J and observations made after 24 hours. Study the diagram and answer the questions that follow.

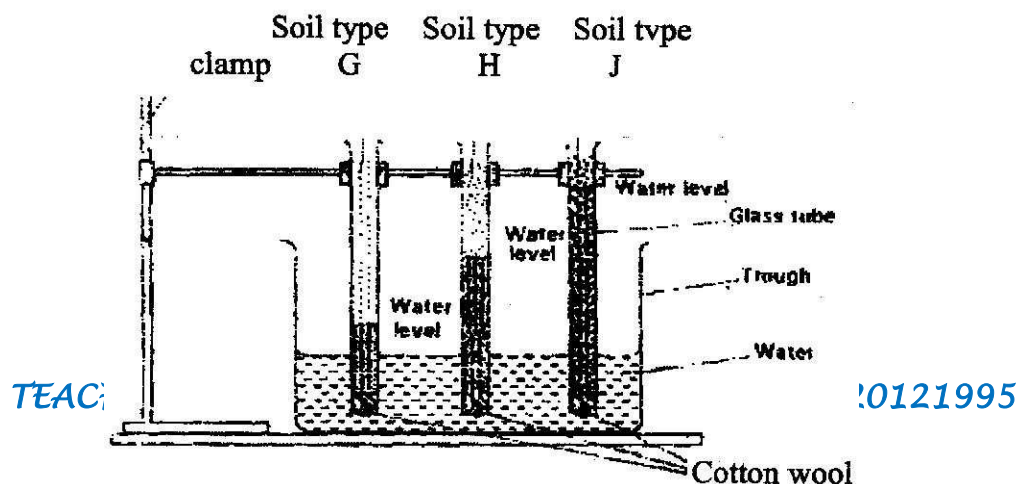

- i) What is the experiment represented above designed to study?
  - ii) Name the three soil types & H and J.
  - iii) What is the characteristic texture of soil types G and J?
  - iv) State how a farmer would improve the structure of soil type G.
10. a) Give 3 reasons why soil is important to crops.
- b) State two benefits of optimum soil temperature in crop production.
- c) Give 3 factors of soil that influence soil productivity.
11. Give three reasons why soil is important to crops.
12. a) Give four reasons why a well drained soil is suitable for crop production.
- b) State two benefits of optimum soil temperature in crop production.
- c) Give three soil factors that influence soil productivity.
13. State three advantages of adding organic matter to sandy soil.
14. a) State two roles of good soil aeration in crop growth.
- b) Give two roles of micro-organisms in the soil that are beneficial to crops.
- c) State three properties of soil that are influenced by its texture.

## FARM TOOLS AND MACHINERY

1. Give one use of each of the following hammers;

- i) Ball pen hammer      ii) Sledge hammer

State two maintenance practices that should be carried out on a wheelbarrow.

2. The diagram labeled N I, N II, N III below represent some tools used in farms.

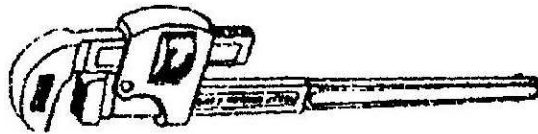

N I-----

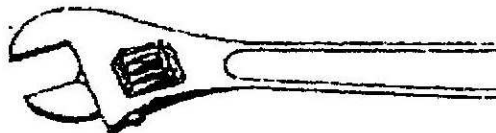

N II

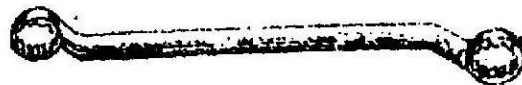

N III

- i) What functional advantage does the tool labeled N II have over the tool labeled NIII?
  - ii) What is the function of tool labeled NI iii) Give the maintenance practice of NI
3. Study the photographs below carefully and answer the questions that follows:



- a) i) Identify 1-----  
2 -----
  - ii) Give the land preparation stage when 2 is used
  - b) i) Which of the tools is suited for a field with roots, trash and other obstacles?  
ii) Give a reason for your answer in b(i)
4. State one use of each of the following tools;
- (i) Spoke shave                      (ii) Plumb bob
5. Name two tools used for cutting galvanized iron pipes.

6. State four maintenance requirements of a jack plane.
7. List four tools used for laying concrete blocks when constructing a wall.
8.
  - a) What is the difference between a tenon saw and a crosscut saw?
  - b) What safety measure should be taken when using a crosscut saw?
  - c) Give three maintenance practices that should be carried out on crosscut saws.
9. Give the factor, that are considered when selecting a garden tool for primary cultivation.
- 10: (a) State one use of each of the following tools, (i) sickle
  - ii) Secateurs.
- b) Give two reasons for proper maintenance of farm implements.
- c) State three factors that should be considered when selecting gardener tools for primary cultivation.
12. L, M, N and O are diagrams of farm tools. Study them and answer the questions that follow.

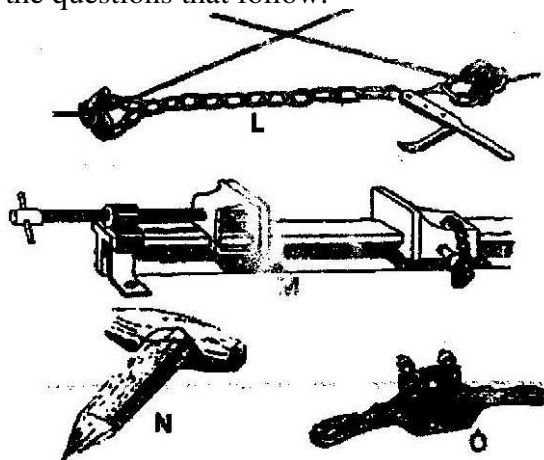

- i) Identify the farm tools; L, AA>N and O. (ii) State the use of each tool  
L, AA, N and O.
13. List the tool used for each of the following
- Tightening barbed wires during fencing,
  - Smoothing concrete floors during plastering.
  - Administration of liquid medicine to livestock through the mouth.
  - Processing butter-----
14. List five tools used when constructing a wooden fence.
15. a) Diagrams M, N, P and Q represents some farm tools.

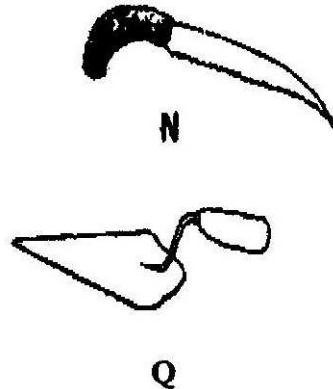
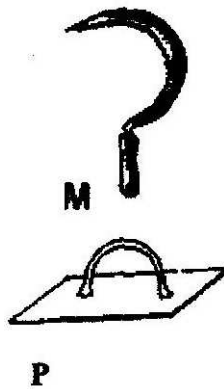

- i) Identify the tools; M,N,P and Q.
  - ii) Give the use of each of the tools named above.
  - iii) State two maintenance practices that should be carried out on tool M.
- (b) The diagram below shows a farm equipment. Study it and answer the questions that follow.

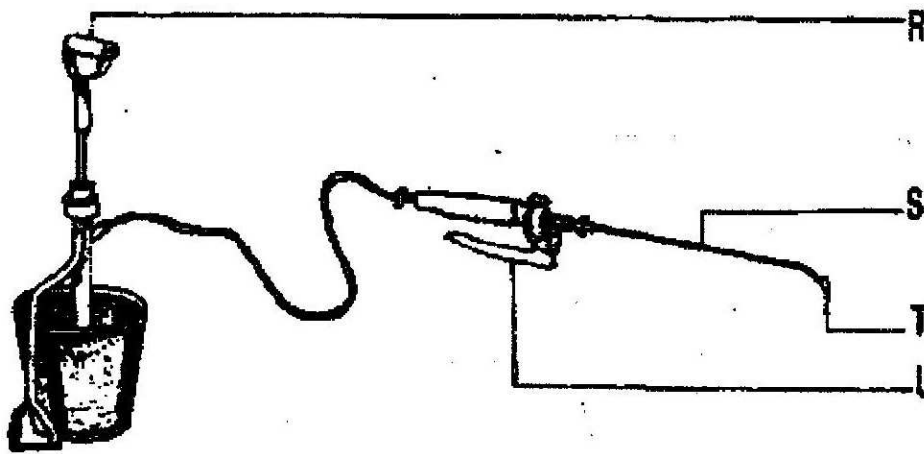

- i) Identify the equipment.
- ii) Name the parts labeled R, S, T and U.



## CROP PRODUCTION – LAND PREPARATION

### **K.C.S.E PAST PAPERS**

1. State 4 reasons for primary cultivation.
2. State four reasons for primary cultivation.
10. State four factors which determine the depth of Ploughing.
3.
  - (a) Give two reasons why the use of fire should be discouraged in clearing land during seedbed preparation.
  - b) Give two reasons for secondary cultivation.
  - c) State two benefits of minimum tillage in crop production.
4. List four implements used to carry out secondary cultivation
5. State two causes of hard pans in a crop field.
6. Give the maintenance practices of a disc plough.
7. State reasons why use of fire in clearing land is discouraged.
8. Outline the main reasons for secondary tillage.
9. State the main benefits of minimum tillage
10.
  - a) State one condition under which a farmer would prefer to use an ox-cart instead of tractor – drawn trailer.
  - b) Give three maintenance practices carried on an ox – plough.
11. Give four farming practices that may help in achieving minimum tillage.

## WATER SUPPLY AND IRRIGATION

### **K.C.S.E PAST PAPERS**

1. Give the main methods of conveying water from place to place.
2. State two methods of storing water on a farm.
3. State two ways of overcoming the problem of water logging in crop production.
4. State four methods of treating water for domestic use.
5. (a) Give two ways of conserving water for livestock use.
6. State two means by which water can be conveyed from the place of Storage to where it is needed on the farm.
7. Name four types of water pumps which can be used on the farm.
8. List two features of plastic pipes a farmer should consider before buying the pipes.
9.
  - a) State three factors to be considered before deciding on irrigation in crop production.
  - b) State three advantages of overhead irrigation compared to surface irrigation.
10. Give four features of plastic pipes a farmer should consider before buying the pipes.
11. Name four types of water pumps which can be used on a farm.
12. Which of these factors would you consider in deciding on irrigation in crop production.

13. In what way is water useful for agriculture activities?
14. a) Explain the reasons for treating water on the farm.  
b) State the uses of water in the farm.  
c) Describe the process involved in water treatment using a chemical treatment system.
15. Give two factors that influence the quantity of water used in the farm.
16. State three farming activities which may cause pollution to water sources.
17. State three advantages of crop irrigation in a farm.
18. Study the illustration below carefully and answer the questions which follow.

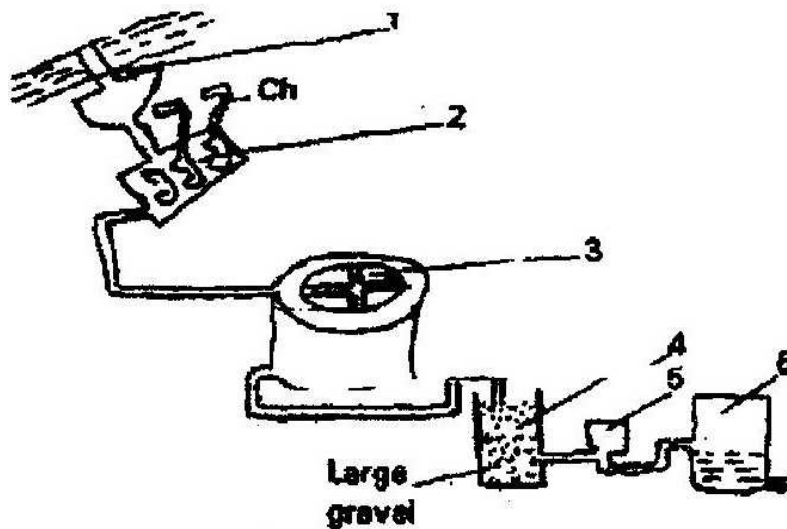

- a) Identify the illustration
  - b) Explain part 1 -6
19. Outline two routine maintenance practices carried out on water storage tanks.
20. List three types of surface irrigation in crop production.
21. List four methods used to drain farm land.
22.
  - a) List three surface water sources found in a farm.
  - b) Give two reasons for treating water before use in a farm.
23. Give the reasons why water treatment is important.

## SOIL FERTILITY – ORGANIC MANURES

### **K.C.S.E PAST PAPERS**

1. How is green maturing carried out on a farm?
  - (a) Give four reasons why it is advantageous to use farm yard manure instead of straight fertilizer.
  - (b) State four factors that determine the quality of farm yard manure.
2. State four ways by which plant nutrients may be lost from the soil.
3. Outline the various benefits of F. Y. M in the farm.
4.
  - a) Define soil fertility
  - b) List the major characteristics of a fertile soil.
5. The diagram below is a presentation of a cross section through a compost Heap. Study it and answer the questions which follow.

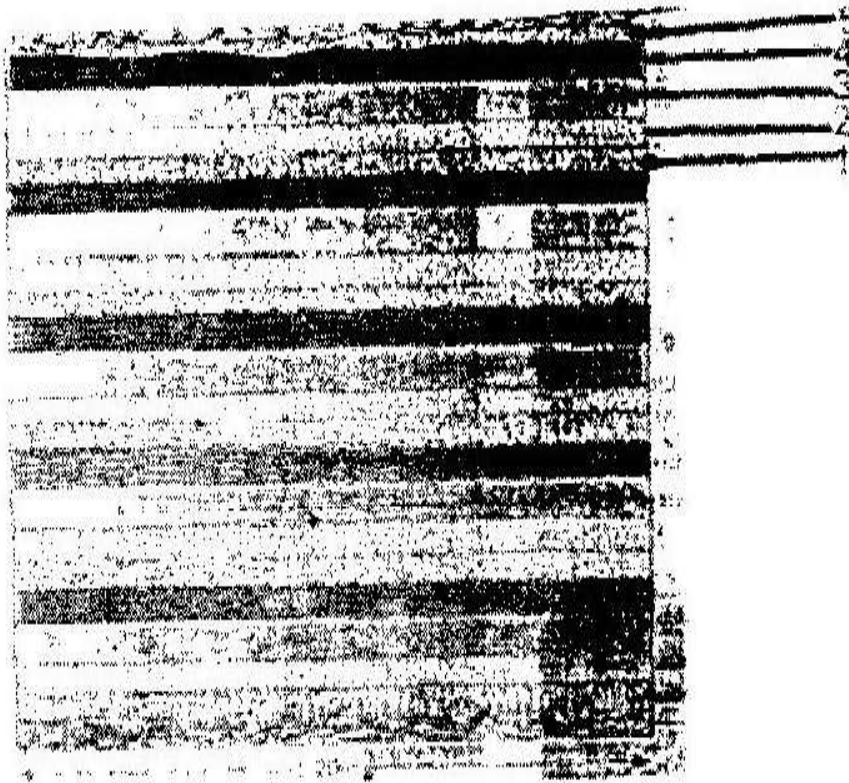

- a) i) Name the parts labeled 1 –  
Give the importance of 5, 4, 3
- b) Why is it advisable that
  - i) A long sharp pointed stick driven into the file at an angle.
  - ii) Compost pits be preferably alone in more drier area / weather.
- 9. Give four ways by which soil loses its fertility
- 10. State four characteristics that make a crop suitable for green manuring.
- 11. State three factors that determine the quality of compost manure.
- 12. State four characteristics of a fertile soil.
- 13. Name three farming practices which may lead to soil erosion.
- 14. State three factors which should be considered when sitting a compost heap.
- 15. State three advantages of adding organic matter to sandy soil.

## **LIVESTOCK PRODUCTION – (COMMON BREEDS)**

### **K.C.S.E PAST PAPERS**

2.           i)     Name the breed of camel that is used for provision of quicker mode of transport and is & better adapted for arid conditions.
- ii)    Give two reasons why this species of camel is well adapted to North par of Kenya.
3.           i)     Give two reasons why jersey breeds is better suited for marginal areas than Friesians breed.
3.           Name the major characteristics of indigenous cattle breeds.
4.           Give the major features of exotic beef breeds
1.           Name the exotic cattle with
  - i)     Highest butter fat content
  - ii)    Lowest butter fat content
5.           State two characteristics of goats that make them adaptable to arid areas of Kenya.
6.           Give three ways used to improve & production in indigenous cattle.

## **AGRICULTURE ECONOMICS – BASIC CONCEPTS AND FARM RECORDS**

### **KCSE PAST PAPERS**

1. List any four types of records a farmer should keep.
2. State four reasons for keeping health records in livestock production
3. State the conditions under which the opportunity cost is Zero in a farming enterprise.



## SOIL FERTILITY II – INORGANIC FERTILIZERS

### KCSE PAST PAPERS

1. State four characteristics of Nitrogenous fertilizers (2mks)
2. Calculate the amount of  $K_2O$  contained in 400kg of a compound fertilizer 25:10:5. (2mks)
3. State four functions of Potassium in plant growth. (2mks)
4. Give two symptoms of potassium deficiency in crops ( 2mks)
5. State four ways by which plant nutrients may be lost from the soil (2mks)
6.
  - a) State three functions of nitrogen in crops (2mks)
  - b) State two symptoms of nitrogen deficiency in a growing maize crop (2mks)
7. State four effects of excessive application of Nitrogenous fertilizers on crop growth. (2mks)
8. Give two functions of sulphur in crops (2mks)
9. Give four deficiency symptoms of phosphorous in crops. (2mks)
10. List four ways of applying fertilizers in crops (2mks)
11.
  - a) Differentiate between macro – nutrients and mirco – nutrients (2mks)
  - b) State four functions of Calcium in plant growth and development (2mks)

## CROP PRODUCTION II – PLANTING

### KCSE PAST PAPERS.

1. State four benefits of using vegetative propagation in orange production.(2mks)
2. (a) Give two advantages of growing cereal crops in rows instead of broadcasting.(2mks)  
(b) Give two reasons for planting crops at correct spacing (2mks)  
(c) Give two factors that determine the depth at which seeds should be planted. (2mks)
3. State any four factors that determine the spacing of a crop (2mks)
4. Give two reasons for sowing annual crops early in the planting season.(2mks)
5. Why should legume seeds be inoculated before planting (1mks)
6. State two benefits a farmer would get by having the correct plant population in the production of annual crops. (2mks)
7. State four factors that influence spacing when planting a pure stand maize. (2mk)
8. Give two factors that would influence the time of planting beans (1mk)
9. Give four reasons for seed selection in crop production. (2mks)
10. State six factors that influence the spacing of an annual crop. (2mks)
11. Give four advantages of under sowing in pasture production. (2mks)

12. (a) Give two harmful effects of high population density in a maize crop growth for grain production (2mks)
- (b) Calculate the plant population per hectares of a maize crop planted at a spacing of 100cm x 50cm. Show your working (2mks)
13. Name two crop production practices carried after planting to achieve optimum plant population. (1mk)
14. State five qualities of the mother plant which should be considered when selecting vegetative materials for planting. (2mks)
15. State four factors that determine the time of planting of a crop. (2mks)
16. Give four disadvantages of planting seed using broadcasting method. (2mks)
17. List four factors that determine (2mks)
18. Give six reasons for timely planting of annual crops. (3mks)

## **CROP PRODUCTION-NURSERY PRACTICES**

### **KCSE PAST PAPERS**

Give a reason for carrying out each of the following practices in a tomato nursery. (2mks)

- (i) Pricking out                      (ii) Hardening off.

Give two activities carried out during hardening off tomato seedlings (2mks)

Give two characteristics of a good root stock for grafting. (1mk)

## **CROP PRODUCTION (IV) – FIELD PRACTICES**

### **KCSE PAST PAPERS**

1. State four reasons for pruning fruit crops (2mks)
2. Give two reasons for drying grains before storage. (2mks)
3. (a) Why is training done in some crops. (1mk)  
(b) Name two crops, which require training.
5. State two factors that determine the stage at which a grain crop is ready for harvesting (1mk)
6. State four benefits of using organic matter for mulching, sounds (2mks)
7. State two ways in which inorganic mulch helps to conserve moisture in the soil (1mk)
8. (a) What is crop rotation? (1mk)  
(b) State three advantages of crop rotation. (1mk)  
(c) State three factors considered when designing a crop rotation programme (2mks)



## **LIVESTOCK HEALTH – INTRODUCTION**

### **KCSE PAST PAPERS**

1. (a) State three advantages of keeping a herd of dairy cattle health.  
(3mks)
2. (a) State two reasons for maintaining livestock in good health. (2mks)  
(b) Name two noticeable diseases in cattle. (2mks)
3. State two ways by which proper feeding contribute to disease control in livestock. (1mk)
4. Explain measures used to control livestock diseases. (12 marks)
5. Give four ways in which diseases can spread can spread from one animal to the other within the farm.

## LIVE STOCK HEALTH – PARASITES

### KCSE PAST PAPERS

1. (a) Which livestock disease is transmitted by each of the following ticks?  
(2mks)

(i) Blue tick (*Boophilous decoloratus*)

(ii) Brown ear tick (*Rhipicephalous appendicula tus*)

- (b) How many hosts does the red-legged tick (*Rhipicephalous averts*)  
require to complete its life cycle? (1mk)

2. (a) State four signs of infestation by external parasites in livestock? (2mks)

3. (a) State four signs of infestation by external parasites in livestock? (2mks)

- (b) Name the intermediate host for each of the following internal parasites.  
(2mks)

Tape worm (*Taenia solium*) (ii) Liver fluke (*Fasciola hepatica*)

4. Describe the life cycle of a three- host tick. (8mks)

5. State four non-chemical methods of controlling ticks in cattle. (2mks)

6. Give four measures that should be taken to control tapeworms on the farm.

(2mks)



## LIVE STOCK PRODUCTION (II) – NUTRITION

### KCSE PAST PAPERS

1. What is a production ration as used in animal nutrition? (1mk)
2. Name two groups into which vitamins are classified. (1 mk)
3. State 3 factors that influence the amount of water intake by a farm Animal. (1<sup>1</sup>/<sub>2</sub> mks)
4. (a) Differentiate between a roughage and a concentrate feed in animal nutrition. (2mks)  
(b) State three ways in which a production ration may be utilized by cattle. (3 mks)
5. Give four characteristics of a livestock roughage feedstuff.
6. Outline four functions of proteins in the body of an animal. (2mks)
7. Outline four factors that determine the nutritional requirements in Cattle (2mks)
8. Give 4 functions of calcium in dairy cow. (2mks)
9. State four factors that are considered when formulating a livestock ration (2 marks)
10. (a) Explain the term “production ration” as used in livestock productions. (1mk)  
b) State four factor which determine the amount of feed an animal can consume. (4mks)
11. State three reasons for feeding livestock. (1<sup>1</sup>/<sub>2</sub>mks)

## LIVE STOCK PRODUCTION (III) - SELECTION AND BREEDING

### KCSE PAST PAPERS.

1. (a) How does crossbreeding improve livestock production.
2. State six signs that are likely to be observed when a cow is on heat
3. State four disadvantages of natural mating as a method of breeding in dairy cattle management.
4. Define the term out crossing in animal breeding.
5. The diagram below shows the reproductive system of a cow. Study it carefully and answer the questions that follow.

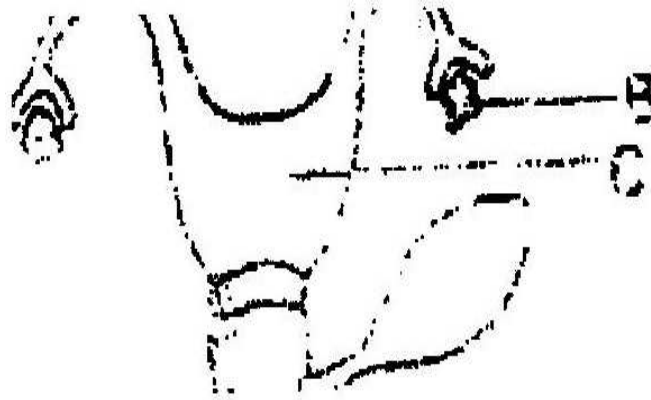

- a)
    - i) Name the parts labeled A B and C.
    - ii) State the function of each of the parts labeled a and b
  - b)
    - (i) Give two methods of mating in cattle
    - (ii) How long is the oestrus cycle in cattle?
6. Explain the term hybrid vigour as used in livestock production.

7. Describe the factors a farmer should consider when selecting a young female pig (Gilt) for breeding.
8.
  - (a) Define the following terms as used in livestock breeding.
    - (i) Inbreeding
    - (ii) Out crossing
  - (b) Outline three disadvantages of artificial insemination in cattle management
  - (c) State three desirable characteristics to be considered when selecting a heifer for milk production.

## LIVESTOCK PRODUCTION (IV) – REARING PRACTICES

### KCSE PAST PAPERS

1. Name two kinds of livestock which can be castrated using a rubber ring.
2. Give four reasons why bees may swarm from a hive.
3. Below is a diagram of a sheep with some parts labeled A, B, and C. Study the diagram and answer the questions that follow.

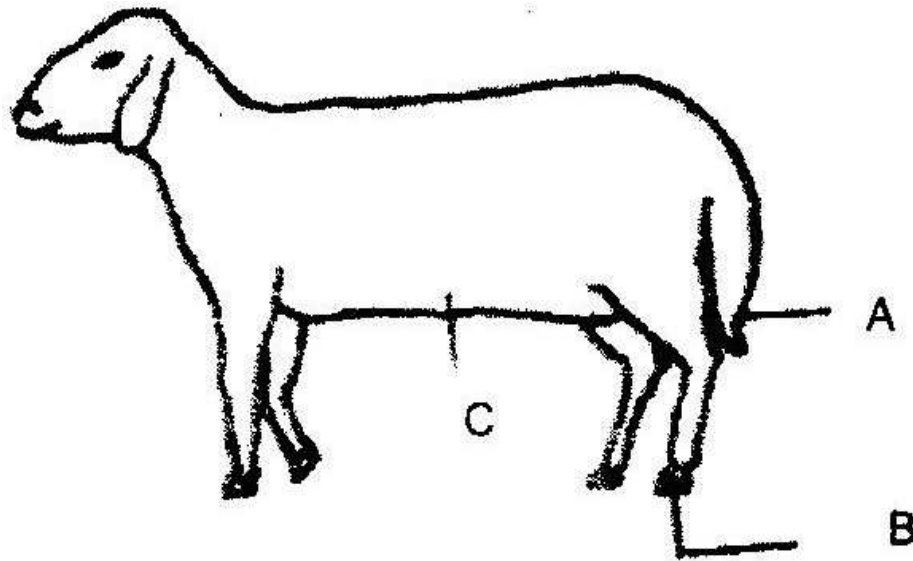

- (i) What operation is usually carried out on the part labeled A during a sheep's early stages of life?
- (ii) Why is it necessary to carry out the operation in (i) above?
- (iii) At what stage of sheep should the operation in (i) above be carried out?
- (iv) Give two methods of carrying out the operation in (i) above,
- (v) Which operation is usually carried out on part labeled B

- (vi) What problem would occur if the operation in (V) above is not carried out?
  - (vii) How should the sheep be held when shearing wool around part labeled C?
4. Why should smoke be used during harvesting of honey?
  5. State four reasons for culling breeding sows.
  6. (a) Define the term colostrums.
    - (c) Explain three qualities that make colostrums suitable for newly born calves.
    - (d) Give three methods of feeding colostrums to a newly born calf.
  6. Give six signs a cow would show just before parturition.
  7. State four reasons for castrating male piglets.
  8. Give two qualities of creep feed that makes it suitable for piglets.
  9. State two reasons why it is necessary to place sugar syrup close to a beehive.
  10. State four routine management practices that should be carried out on a lactating ewe.
  11. State six management practices in fish rearing.
  12. Give five signs, which indicate that a sow is about to farrow.
  13. State four conditions which would make it necessary to feed bees.
  14. State four management practices that should be carried out during the mating season in sheep.
  15. Name four species of fresh water fish reared in Kenya.

## FARM STRUCTURES.

1. The diagram below represents a calf pen. Study it to answer the questions that follow.

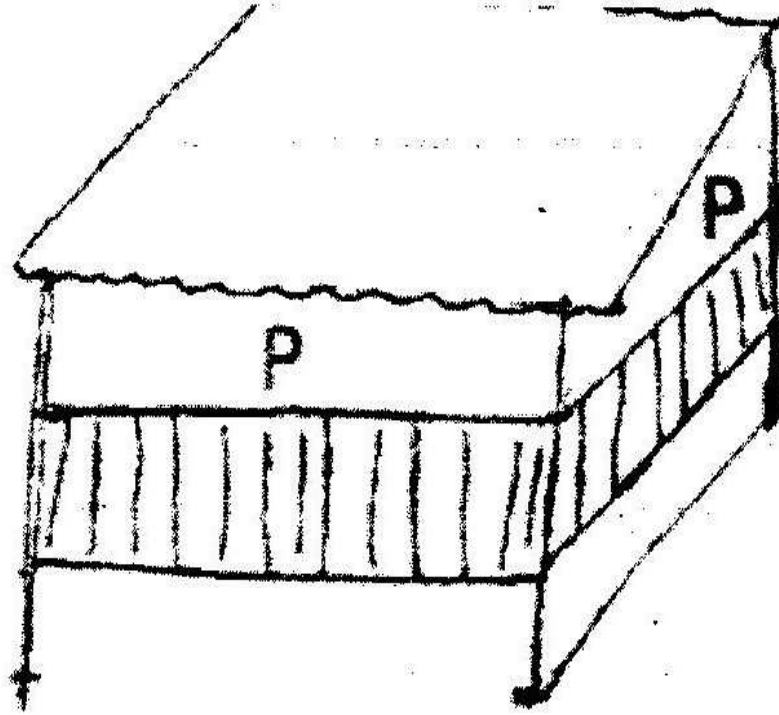

- (i) How high should the floor be above the ground level?
  - (ii) Why should the floor of the calf pen be raised?
  - (iii) Why should the parts of the pen marked p be open?
  - (iv) State three factors that should be considered in sitting a calf pen?
2. State two advantages of using wood in the construction of farm buildings
3. Describe the construction of a rabbit hutch under the following sub-headings.
4. Give two reasons for treating timber to the used in construction of farm

buildings.

5. State one advantage and one disadvantage of using barbed wire instead of plain wire for fencing paddocks.
6. State two functions of ventilation in an animal house.
7.
  - a) One of the recommended ratio of mixing ingredients for making Concrete block is 1:3:4, Name ingredients represented by the numbers 1, 3 and 4 in the mixture.
  - b) If stronger concrete blocks were to be made, name the ingredient that would be increased.
  - c) State three properties of concrete that make it suitable for constructing farm buildings.
  - d) In addition to concrete, name three other materials that would be required to construct the floor of milking shed.
8. State four features of a good maize granary.
9. State two reasons why maintenance of farm structures is important.
10.
  - a) State any four factors that would influence the siting of a calf pen.
  - b) State four factors to consider when selecting materials for constructing a calf pen.
  - c) Give four maintenance practices that should be carried out on a permanent calf pen.
11. Give two practices, other than use of preservatives, that can be carried out on wooden fencing posts to make them last long.
12. State six features of an ideal calf pen.

13. Outline any four maintenance practices that should be carried out in a deep litter poultry house.
14. Give two advantages of concrete blocks over timber as building materials.
15.
  - a) State the uses of fences in farms.
  - b) What factors would be considered when sitting a farm structures.
16.
  - a) State four advantages of a hedge in a farm.
17. State four advantages of using a Kenya Top Bar Hive over log hive.
18. Outline two routine maintenance practices carried out on water tanks.
19.
  - a) Explain the uses of various hand tools in the construction a Kenya Top Bar Hive
  - b) Describe the procedure of erecting wooden posts for fencing.
20. State three disadvantages of using steel in construction of farm buildings.



## **SOIL AND WATER CONSERVATION**

### **KCSE PAST PAPERS**

1. Give one way through which check dams control soil erosion.
2. State two ways by which trees help in soil conservation.
3. State two reasons for carrying out soil conservation in a farm.
4. State two ways by which grass cover help to conserve soil.
5. State two ways by which inorganic mulch help to conserve water in the Soil.
6. Define the terms;
  - a) Forestation
  - b) Re-a forestation
7. Outline three factors, which may influence soil erosion.

## WEEDS AND WEED CONTROL

### KCSE PAST PAPERS

1. State four reasons why timely weed control is advisable in crop production.
2. Give four ways of controlling weeds in a maize field. (2mks)
3. PP2: Diagram & and H show weeds.
  - i) Identify the weeds. (2mks)
  - ii) State the economic importance of the weed shown in diagram G (2mks)
  - iii) Why is it difficult to control weed in diagram G? (1mk)
4. State six disadvantages of weeds in crop production (3mks)
5. (i) State four factors that contribute to the competitive ability of weeds. (2mks)
6. The diagram below represents a weed.



- i) Identify the weed (1/2 mrks)
- ii) Classify the weed according to its life span. (1/2 mark)
- iii) State one harmful effect of the weed to livestock. (1mk)

## **AGRICULTURE ECONOMICS (II)- LAND TENURE AND REFORMS**

### **KCSE PAST PAPERS**

1. State four disadvantages of communal land tenure system.
2. Give two ways in which land consolidation helps to improve farm management.
3. State four objectives of land settlement which have been undertaken in Kenya
4. Give two forms of collective land tenure system in

## CROP PESTS AND DISEASES

### KCSE PAST PAPERS

1. PP2

Below is a diagram of a bird labeled A. Which is a crop pest?



- i) Identify the pest
  - ii) State two ways by which the bird causes loss in crops.
  - iii) State four methods, which are used to control the pests.
2. The diagram labeled D below shows a Kale crop invested by a pest

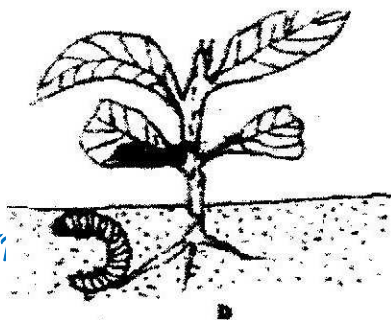

- i) Identify the pest.
  - ii) What damage does the pest cause the crop?
  - iii) State two methods of controlling the pest
3. Give two methods of controlling the pest?
  4. State two cultural methods of controlling bollworms in a crop of cotton.
  5. Give two ways of controlling bacteria blight in cotton.
  6. State four factors that affect the effectiveness of a pesticide.
  7.
    - a) State two feeding habits of field insect pests.
    - b) State two cultural methods of pest control in stored grains.
  8. Explain how various practices carried out in the field help to control crop diseases.
  9. State three cultural ways of controlling nematodes in a field of bananas.
  10.
    - a) Define the term "Economic Injury Level" of a crop.
    - b) Give two ways by which pesticides kills crop pests.
    - c) State four disadvantages of chemical pest control in crop production.
  11. Give three harmful effects of pests in crop production
  12. State two cultural methods in controlling bollworms in a tomato crop.
  13. Give two possible causes of swelling on the roots of bean plants.

## CROP PRODUCTION (VI) FIELD PRACTICES (II)

### **KCSE PAST PAPERS.**

1. Name two field pests and two diseases of millet.
2. Why is it advisable to apply a straight nitrogenous fertilizer to a crop of maize at a height of 30 – 45cm.
3. Which disease causes a mass of dark spores on the flowering parts of maize?
4. State any four non – chemical methods of controlling storage pests in a maize granary.
5. List four insect pests of maize in storage.
6. PP2 The diagram below labeled G, H, J and K shows different stages of cotton fruit.

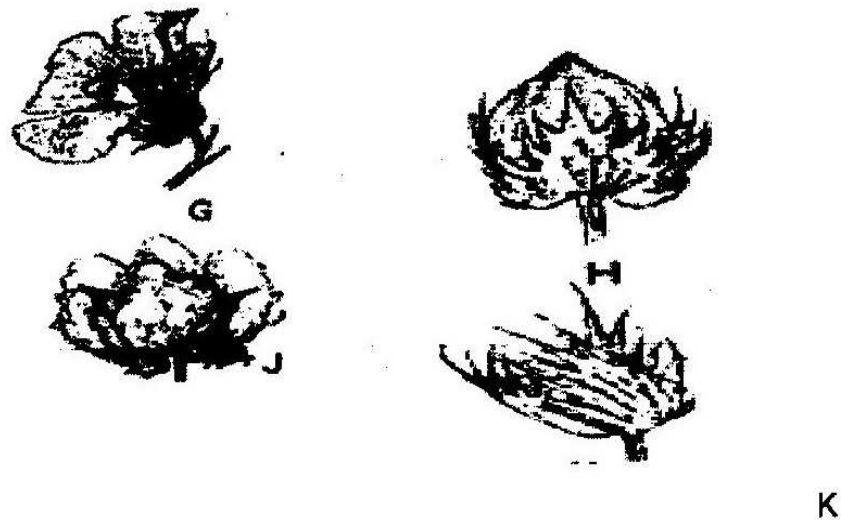

- i) Rearrange the label G, H, J, and K to show the correct sequence in which the cotton fruit develops.
  - ii) What would be the effect of attack by cotton boll worms at the stage labeled K?
  - iii) State two conditions that should be observed when harvesting to ensure that cotton picked is of high quality.
  - iv) Name the two products which are obtained after processing cotton.
7. State four practices used to control maize streak in the field.
8.
  - i) State two cultural methods of controlling pests in an established field of sorghum.
  - ii) List any four insect pests that attack maize in the field.
9. Give four ways of controlling weeds in a field of maize.
10. Give four control measures of maize streak virus.



## **FORAGE CROPS**

### **KCSE PAST PAPERS.**

1. State two advantages of establishing a mixed grass legume pasture instead of planting a pure grass pasture.
2. Give two disadvantages of overstocking in cattle production.
3. State two roles of additives in silage making.
4.
  - a) Define the following term, (i) Under sowing (ii) Over sowing
  - b) State three methods of controlling weeds in a pure grass pasture.
  - c) Give three benefits of top dressing in the management of grass pastures.
5. State four ways by which a farmer can make efficient use of a pasture crop.
6. Give four factors that determined the nutrient content of hay.
7. State four advantages of under sowing in pasture production
8. Describe field production of Napier elephant grass under the following sub-headings.
  - i) Seedbed preparation
  - ii) Planting
  - iii) Fertilizer application
  - iv) Weed control
  - v) Utilization

9.
  - (a) List three pasture legumes grown in medium altitude zones.
  - (b) Give three advantages of rotational grazing.
  - (c) State three ways by which overheating can be prevented in the process of making silage.
10. State two advantages of proper stocking pasture management.
11. Explain the following terms as used in pasture establishment.
  - a) Seed Inoculation
  - b) Over sowing

## LIVE STOCK HEALTH (III) – LIVESTOCK DISEASES

### KCSE PAST PAPERS.

1. List six routes through which pathogens can enter the body of an animal.
2. State two methods of controlling rinder pest disease in cattle.
3. Give four symptoms of Newcastle disease in poultry.
4. State four predisposing factors to the occurrence of mastitis in dairy cattle.
5. State any three symptoms of mastitis in dairy cattle.
6. Name two notifiable diseases in cattle.
7. State two measures that should be taken to prevent an outbreak  
of Newcastle disease in poultry.
8. **PP2:** The diagram below shows the head of a chicken having  
symptoms of a poultry disease.
  - i) Identify the disease
  - ii) Give two reasons why the disease is of economic importance  
to the farmer.
  - iii) State any two methods of controlling the disease.
9. State four symptoms of foot rot in sheep.
10. Name the causal agents for each of the following disease,
  - i) Coccidiosis
  - ii) Black quarter
11.
  - i) State two predisposing factors of foot rot in sheep.
  - ii) Give three symptoms of anaplasmosis disease.

12. Explain measures used to control livestock diseases. (12mks)
13. Give two signs that would indicate that a cow has died of anthrax.
14. a) Name the causal organism of brucellosis in cows (1mks)  
b) Give two symptoms of brucellosis in cows.  
c) State four measures that should be taken to control brucellosis in cattle.
15. Give three methods of controlling rinderpest in cattle.
16. Mention four symptoms of East Coast Fever in cattle.
17. a) State the cause of milk fever in dairy cows. (1mks)  
b) Give four symptoms of milk fever in dairy cows.  
c) State two methods of controlling milk fever.

## **LIVESTOCK PRODUCTION – POULTRY**

### **KCSE PAST PAPERS**

1. Give three methods of controlling cannibalism in a flock of layers in deep litter system.
2. List four factors that should be considered when grading eggs for marketing.
3.
  - a) Describe the artificial rearing of layer chicks from day old up to the end of brooding.
  - b) Describe the characteristics of a poor layer, which should be considered during culling
4. Outline any four maintenance practices, which should be carried out in a deep litter poultry house. (2mks)
5. Give four conditions that reduce the quality of eggs for hatching. (2mks)
6. Give four measures that can control egg eating by hens in a deep litter system (2mks)
7.
  - a) State four observations on the behaviour of chicks which would indicate that the temperature of a brooder is too high. (4mks)
  - b) Give four advantages of deep litter system of poultry keeping. (4mks)
8. List six qualities of eggs suitable for incubation (3mks)
9. Describe the steps to be taken in maintaining hygiene in a deep litter poultry house. (5mks)

**LIVESTOCK PRODUCTION (VI) – CATTLE**

**KCSE PAST PAPERS.**

1. (a) The diagram below is a cross section of part of a cows udder

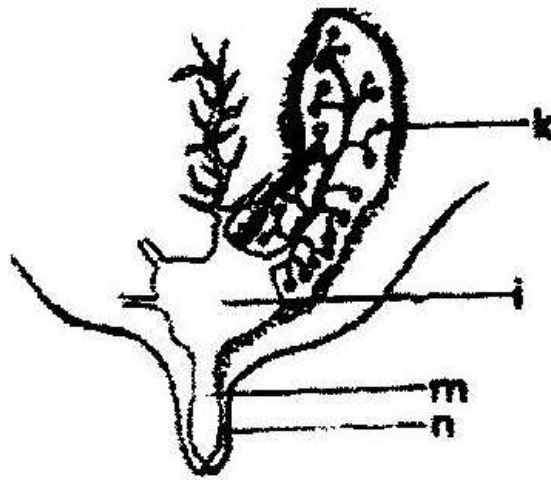

- Label on the diagram the parts marked k, l, m and n. (2mks)
- (b) i) What is milk let down? (1mk)
- ii) Which hormone stimulates milk let down. (1mk)
- (c) State three practices which are carried out to control mastitis in lactating cows.
2. Describe the management of a dairy heifer calf from birth until it is mature for first service. (20mks)
3. a) Name any two characteristics of good quality whole milk. (1mk)
- b) State three advantages of artificial calf rearing. (3mks)
4. State four qualities of clean milk. (2mks)

- a) Define the term colostrums (1mk)
- b) Explain three qualities that make colostrums suitable for newly born calves. (3mks)
- c) Give two methods of feeding colostrums to a newly born calf. (1mk)
5. State any six practices that would ensure clean milk production (3mks)
6. State six marketing problems affecting dairy farming in Kenya. (3mks)
7. Describe the management of a dairy calf using artificial rearing method from birth to weaning (20mks)

## FARM POWER AND MACHINERY

### KCSE PAST PAPERS

1. (a) States four advantages of farm mechanization (2mks)
- (b) Give the functions of each of the following parts of a mould board plough. (4mks)
- (i) Mould board (ii) Share
- (iii) Frog (iv) Landslide.
- (c) Give two daily maintenance practices that should be carried out on a mould board plough. (2mks)
2. The diagram below is a tractor drawn implement hitched at the rear of the tractor.

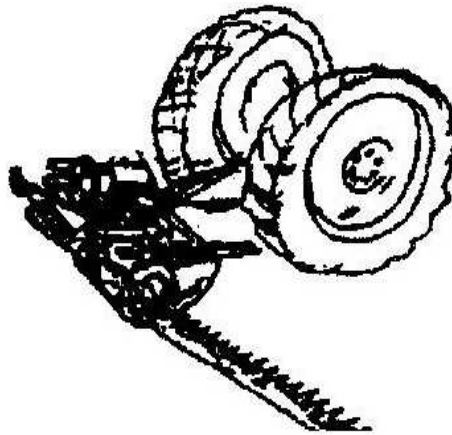

- (i) Identify the implement (1mk)
- (ii) What is the method of power transmission for operating the implement? (1mk)
- (iii) State three maintenance practices that should be carried out on the



- implement. (3mks)
3. a) Compare the use of an ox-drawn mould board plough with that of a tractor-drawn mould board plough. (9mks)
- b) Describe the maintenance practices that should be carried out on an ox-drawn mould board plough (6mks)
- c) What are the advantages and disadvantages of using tractor hire service farming instead of owning and using your own tractors. (5mks)
4. a) State two reasons of applying oil and grease on a rotary mower. (2mks)
- b) State four maintenance practices required on a rotary mower besides oiling and greasing. (2mks)
- c) State four factors that a farmer should consider before buying a tractor for use as the source of power on the farm. (2mks)
5. a) Give two uses of ox –drawn harrow (2mks)
- b) Give two maintenance practices of a ox-drawn tine harrow. (2mks)
- c) State two advantages of an ox- drawn harrow over tractor-drawn harrow. (2mks)
6. Out line four maintenance practices of a disc harrow. (2mks)
7. a) State one method of increasing ploughing depth when using a disc plough. (1mk)
- b) State two reasons for maintaining a disc plough, (2mks)
- c) State three advantages of farm mechanization. (3mks)

8. a) State two functions of a coulter in a mould board plough. (2mks)
- b) Give three maintenance practices carried out on an Ox-drawn trailer. (3mks)
9. a) State two problems associated with tractor hire service that farmers encounter. (1mk)
- b) List four implements used to carry out secondary cultivation. (2mks)
10. a) State one condition under which a farmer would prefer to use an ox-cart instead of a tractor-drawn trailer.
- b) Give three maintenance practices carried out on an ox-plough. (3mks)



6. a) Below is a graphical representation of The law of admonishing returns.

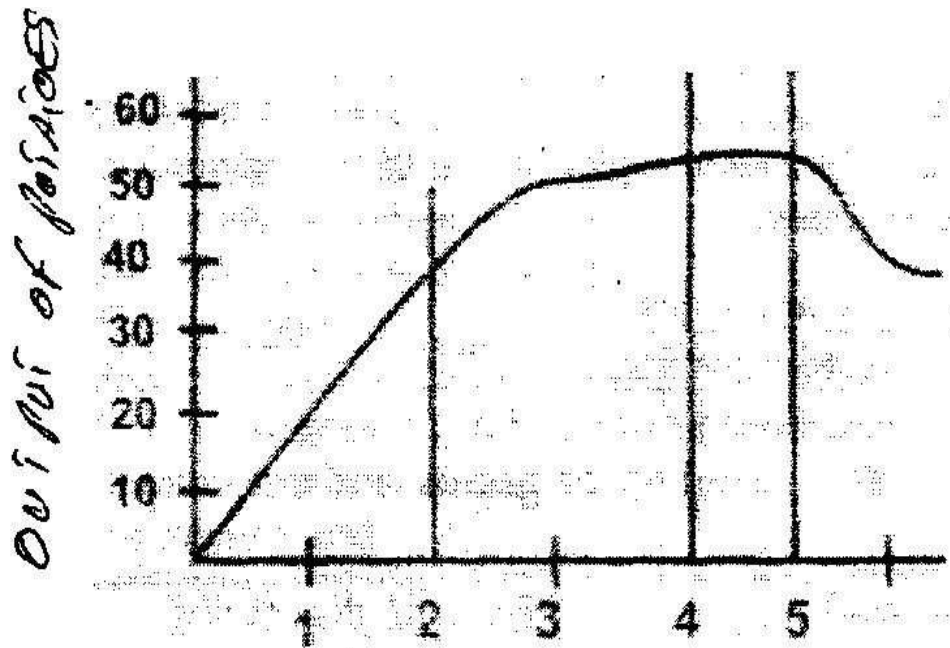

- a) Explain what happens in each of the Zones marked I, II and III in relation to output. (3mks)
- b) Which of the three is a rational zone of production? (1mks)
- c) State any three precautions a potatoes farmer would take to minimize risks in the production of potatoes. (2mks)
7. a) State three ways of improving labour productivity in a farm.
- b) Give two changes that would indicate improvement of labour efficiency in farm. (2mks)

- c) State two ways of determining the rate of payment of casual labour in a farm. (3mks)
8. a) State four factors that influence the supply of casual labour in a farm. (2mks)
- b) State six ways by which a farmer can risk and uncertainties.
- c) State six reasons why agriculture is important in Kenya economy. (3mks)
9. State 2 reasons for choosing the right enterprise combination in farming business. (1mks)
10. a) Give four examples of joint products in livestock production.
- b) List four variable inputs in poultry production.
- c) A farmer can combine dairy meal and home made in

Dairy meal (kg)	Home made feed (kg)	Marginal rate of substitution
1	48	O
2	39	V
3	32	7
4	27	W
5	23	4
6	21	X
7	20	1
8	19	y

- i) Given the above information, calculate the marginal rate of substitution and give values of V, W, X and X (4mks)

- ii) Given that the price of dairy meal is Ksh. 8.00 per kilogram and that of homemade feeds is Ksh. 2.00 per kilogram, calculate the least cost combination. (1mks)
11. a) Name three – product relationship in agriculture economics.  
 b) Explain the following terms as used in agriculture economics.  
 i) Production function  
 ii) Equi–marginal returns.
12. Name five sources of agriculture credit in Kenya (1 ½ mks)
13. Give two examples in each case of the following costs incurred in the production of milk.  
 a) Variable costs (1mk)  
 b) Fixed costs (1mks)
14. a) Differentiate between partial budget and complete budget. (2mks)  
 b) Explain how factors may adjust uncertain rules in farming business (2mks)

The cost of fertilizer is Kshs. 1500 per unit and the price of maize is Ksh. 1200 per bag.

- i) At what unit of fertilizer input should the farmer be advised to stop applying any more fertilizer to the maize.  
 ii) Give two reasons for your answer in b (i) above.  
 iii) Calculate the marginal return at the point of optimum production.

## AGRICULTURAL ECONOMICS

### (FARM ACCOUNTS)

1.           a)     List four types of financial books farmers should keep. (2mks)
- b)     State two uses of a balance sheet. (2 mks)
2.           Study the following information which was extracted from Mr. Rambo's farm record on 31 -12 – 95 and answer the question below.

	Kshs.
Loans payable to bank	300,000
Five milking cows	250,000
400 layers	80,000
20 goats	30,000
Debts payable to cooperative	20,000
Buildings and structures	600,000
Bonus payable to workers	19,000
Cattle feed in store	10,000
Animal drugs in store	4,000
Debts receivable	18,000
Breakages to repair	30,000
I cash at hand	20,000
I Cash in bank	30,000
Spray equipment	12,000

Prepare a balance sheet for Rambo's farm using the information above 7 mks

3. a) Explain the following terms as used in farm account.
- i) Cash account
  - ii) Ledger
  - iii) Balance sheet
  - iv) Purchase order.
- Name two types of inventories used in farm accounts. (2mks)

4. On 5 – 1- 2001 Tamu farm purchased on credit the following items from a K. F. A shop.

- 20 bags of dairy meal, 70kg each @ sh. 1,100 per bag.
- 16 bags of bran, 70kg each @ sh. 700 per bag.
- 18 bags of D.S.P fertilizer, 50kg each @ sh. 1,500 per bag.
- 45 bags of seed maize, each 2kg @ Ksh. 300 per bag.
- 8 shearing knives (medium size) @ sh. 300 per knife.

- i) Prepare the purchase order that Tamu farm made to K.F.A. (6mks)
- ii) Calculate the value of each item purchased and the total value of the order. (3mks)

5. The following accounts information is from Mrs. Mbuta's farm for the year ended 31 – 12 – 2003.

Opening valuation	Ksh. 6,000/=
Paid wages	Ksh. 5000/=
Bought equipment worth	Ksh. 8,000/=
Bought pig feeds worth	Ksh. 4,000/=
Sold mature pigs worth	Ksh. 7,000/=



Bought drugs worth                      Ksh. 3,200/=

Sold maize worth                         Ksh. 3,000/=

Closing valuation                         Ksh. 4,000/=

- i) Using the information above, prepare a profit and loss account for Mrs. Mbuta's farm.
  - ii) From the calculations in (i) above, state whether Mrs. Mbuta made a profit or a loss. (1mk)
- 6.
- a) What is opening valuation as used in farm account? (1mks)
  - b) State the use of each of the following financial documents (3mks)
    - i) Cash receipt
    - ii) Purchase order.
    - Mi) Delivery note.

## AGRICULTURAL ECONOMICS

### (AGRICULTURAL MARKETING AND ORGANIZATION)

1.
  - a) What is the minimum number of people required to form a co-operative society? (1mks)
  - b) State four factors that may influence the supply of a commodity in a market? (4mks)
  - c) State four problems that farmers are likely to face when marketing their produce. (4mks)
  - d) Name two marketing organizations for coffee in Kenya. (1mk)
2.
  - a) Differentiate between market and marketing? (2mks)
  - b) What is an imperfect market? (1mk)
  - c) How will the price of mangoes in the short run be affected if the quantity of mangoes supplied in a market is increased
  - d) State any four problems a dairy farmer is likely to face in marketing milk. (2mks)
3.
  - a) State the law of demand. (1mk)
  - b) State four factors that determine the demand of a commodity in a free market economy. (4mks)
  - c) What is elasticity of demand for a commodity? (1mk)
  - d) Explain the functions of agricultural marketing boards. (15 mks)
4.
  - a) Give four benefits a farmer would derive from being a member

- of a dairy co-operative society. (2mks)
5. a) Explain the problems farmers face in marketing of agricultural produce. (9mks)
- b) Describe the various agencies and institutions involved in marketing of a agricultural produce. (5mks)
6. a) State six factors that influence demand for a commodity in a market. (3mks)
7. a) Given that at a price of Ksh. 100 per bag, 20 bags of maize are demanded, but when the price changes to Ksh.800 per bag, 22 bags of are demanded. Calculate the elasticity of demand. Show your working. (3mks)
8. a) Describe the functions of agricultural marketing (10mks)
- b) Explain the role of agricultural co-operatives in Kenya. (10mks)
9. a) State six problems experienced by farmers in marketing agricultural produce. (3mks)

# MARKING SCHEMES

## TOPICAL

### INTRODUCTION TO AGRICULTURE.

1. This is a system of farming in which one crop is grown in large scale.
2. **Characteristics of shifting cultivation.**
  - When fertility of the soil goes down crops are not grown again until fertility is restored.
  - Plenty of land is available to the farming community
  - Practicable with annual crops not with the perennials.
  - Agricultural output from the whole system is low / subsistence production.
  - Input such as pesticides, fungicides, fertilizers are rarely used / build up of pests and diseases is avoided by periodic movements to the new lands.
  - Use of simple hand tools.
3.
  - It is a source of food for the population.
  - Earns foreign exchange for the country
  - Provides market industrial goods.
  - Farmers earn a lot of income
  - Provides employment both directly and indirectly.

4.

- Providing market for industrial goods.
- Providing raw materials that are used in industries.

5.        **Limitations of pastoral farming**

- Drought and aridity Diseases and parasites.
- Diseases and parasites
- Attack by wild animal
- Soil erosion due to over stocking
- Poor pastures species
- Inadequate land/over population.

6.

- Low production
- Uncontrolled mating
- Difficult to control parasites and diseases
- Leads to overgrazing hence soil erosion.

## **FACTORS INFLUENCING AGRICULTURE.**

**1.**

- Temperature/altitude
- Prevailing winds
- Soil types
- Rainfall

**2.**

- Cause physical damage / breakages to crops (accept any physical damage)
- Causes water stress / increases rate of transpiration in crops.
- Spread crop pests, diseases and weeds.
- Can cause stress to crops due to chilling caused by cold air.
- Cause soil erosion leading to loss of soil fertility.
- Encourage transpiration hence water and mineral uptake.

**3.**

- Rainfall intensity
- Rainfall reliability
- Rainfall distribution
- Rainfall amount

4.

- Poor soil fertility due to lack of manure and fertilizer application.
- Less rainfall/unreliable rainfall/too much rainfall.
- Poor soil type leading to water logging or excess leaching.
- Inappropriate pH/poor soil pH.
- Pest attack
- Poor weed control leading to competition.
- Too high or low temperature / inappropriate temperature.
- Excess wind that increase evapotranspiration/lodging of crop/floral abortion.
- Inappropriate humidity, either too high or too low.
- Extreme light intensity that may reduce photosynthesis / exhaustion of nutrients.
- Inappropriate topography that may limit crop growth.
- Hailstorm damage.

5.

- Decompose organic matter.
- Help to aerate the soil
- Atmospheric Nitrogen to nitrates.
- Upon death and decay release plant nutrients.

6.

- Ploughing at the same depth season after season
- Use of heavy machinery on wet soil.

7. a)

- Physical weathering

- Biological weathering
- Chemical weathering

b)

- Soil texture is the relative proportion of the different sized particles in the soil;
- Soil structure is the general appearance of the soil in relation to the arrangement of the individual soil particles.

c)

- Allows proper infiltration/drainage of water
- Has good aeration.
- It is not easily eroded.

**8.**

a)

- Light intensity.
- Light wavelength
- Light duration / photosynthesis

b)

i) Capillarity in the three different soil samples.

ii) G – Sandy soil

H – Loam soil

J – Clay soil

iii) G – Rough and coarse texture

J – Fine textured



iv) Addition of organic manure – Addition of lime

9.

a) **Why soil is important to crops.**

- Supports plant life anchorage.
- Provides nutrients and water
- Contains organic matter, food for micro – organism

b) **Benefits of optimum soil temperature.**

- Increase the rate of bio chemical reactions hence breakdown of materials to form organic matter i.e. for every 10°C rate doubles.
- Activates soil micro – organism especially the useful bacteria for nitrogen fixation,
- Ensures maximum activities for bio chemical enzymatic reactions that bring about growth e.g. germination process.

c) **Factors of soil which influence soil productivity.**

- Good supply of plant nutrients and oxygen.
- Good depth
- Good drainage
- Abundance of useful soil and organism
- Adequate water retention.
- Freedom from plant pests and disease causing agents.

10.

- Provide anchorage to crop roots
- Provide nutrients to crops

- Provide water to crops
- Hold air/oxygen for crop growth.

**11.** a)

- Good aeration is necessary for root respiration.
- Suitable for microbial activity
- Easy to work on.
- Raises soil temperature
- Removes toxic substances e.g. sodium, iron and magnesium salts.

b)

- Enhance seed germination
- Enhances plant growth.
- Enhance soil microbial activities
- Improves quality of crops e.g. Tea, pineapples.

c)

- Soil depth / drainage / aeration
- Water holding capacity
- Level of nutrients / cation exchange
- Soil pH/ Soil borne – pests and diseases.

**12.**

- Improves soil structure
- Reduces leaching.
- Improves water holding capacity
- Increase cation exchange capacity

- Improve nutrient status upon decomposition
- Moderate soil temperature. Buffer the soil pH.

## FARM TOOLS AND EQUIPMENT

1.
  - i) – Riveting / flattening metal sheets / driving cold chisel
  - ii) – Breaking / crushing hardcore / big stones  
- Driving wedges into wood.

2.

- N I – pipe wrench
- N II – Adjustable spanner
- N III – Ring spanner
  - i) Holds different sizes of nuts and bolts.
  - ii) NI is used for holding pipes during plumbing work.
  - iii) Maintenance of NI – Lubrication of adjustable screw.

3.

- a)
  - i) 1 – Disc harrow  
2 – Disc plough
  - ii) Secondary cultivation / Harrowing
- b)
  - i) 2 (Disc plough)
  - ii) It is able to ride over obstacles, bouncing on its springs.

4.

- i) Smoothing rounded/curved edges of timber.
- ii) To check verticalness of an upright object.

5.

Hacksaw / pipe cutter.

6.

- Cleaning it after use.
- Lubricating the adjustment screw.

- Sharpening the plane iron / blade
- Tightening loose screws and nuts.
- Proper storage
- Replacing the broken parts.

7.

- Spirit level/trowel/float.
- Plumb bob/plumb line.
- Mason's square/tape measure.
- String/line/mason's hammer
- Mason's chisel/bolster.

8. (a)

- A tenon saw is shorter
- A tenon saw has a rigid frame at the back
- Unlike a cross cut saw.
- A tenon saw has more teeth per unit length
- Than a cross cut saw.
- A tenon saw is used in joinery work while the cross cut saw cuts wood across the grains.

b)

- Hold the work firmly.
- Ensure the saw is in good working condition / straight blade / sharp teeth / well set teeth/firm handle.

c)

- proper storage after use
- Oil the blade to avoid rusting
- Sharpen the teeth
- Set the teeth properly
- Tighten the handle screws if loose / replace broken handle.

9.

- Soil type/ hardness of the soil
- Vegetation covers of the field.
- Cost of the tool. Skills required
- Availability of the tool
- Availability of capital

10. **When to use a Jembe and not a disc plough.**

- When the land is very steep.
- Lack Technical skills in operation of disc plough
- When size of land is too small
- When capital is inadequate to acquire a disc plough.
- When it is cost effective to use a Jembe.
- When disc plough is not available.
- When inadequate time is available
- When land is rocky / stony.

11. a)

- i) – Pruning / cutting crops
  - Harvesting rice / grasses

ii) Pruning

- Cutting vegetative materials for planting / harvesting flowers.

b)

- To avoid injury to the user.
- To reduce repair / replacement cost
- To increase their durability / life span
- To make them more efficient.

c)

- Soil type/hardness of soil.
- Vegetation cover of the field
- Cost of the tool
- Skill required / availability of the tool
- Availability of capital.

**12. (i)**

L – Monkey strainer / wire strainer.

M – Sash clamp

N – Dibber

O – Spoke

**(ii)**

L – Touting fencing wire during fencing.

M – Holding pieces of timber together when joining them together. i

N – Making holes for transplanting. J

O – Smoothing curved/round edges of timber.

**13. Tools used.**

- i. Monkey strainer/wire strainer.
- ii. Steel/wood float
- iii. Drenching gun.
- iv. Butter churner.

**14.**

- Hand saw/bow saw.
- Claw hammer/plumb bob
- Hole digger/soil auger/panga.
- Ramming rod/builders trowel.
- Soil scoop/spade/shovel.
- Tape measure/mallet/garden line.

**15.**

(a) M – Sickle

N – Pruning saw

P – Float

Q – Garden trowel.

(b) M – Harvesting rice/grasses

N – Pruning/cutting stems/branches in crops e.g. coffee citrus.

P – Spreading screed on concrete floors/wall

Q – Transplanting seedlings



## LAND PREPARATION

1.

- To kill the weeds
- Bury crop residues/organic matter into the soil
- Loosen up the soil/facilitate rainfall infiltration/improve aeration/easy penetration of roots.
- Control soil borne pests/diseases by destroying their life cycles.
- Make subsequent operations easier.

2. (ii)

- Clean after use.
- Hammer bent share
- Replace worn out parts e.g. hooks, share.
- Check, tighten loose nuts and belts during the day's work
- Oil shiny parts e.g. mould board, if of use.
- Paint metallic parts e.g. handle, beam and braces, to prevent rusting.
- Store properly in a shed.

3.

- To kill weeds
- To bury organic matter/crop residual into the soil
- To loosen up the soil/improve aeration/improve water infiltration/improve root penetration. To control soil borne pests/diseases.
- To make subsequent operations easier.

4.

- Type of crop/rooting system of crop to be grown.
- Type of implement available.
- Type of soil.
- Soil moisture content at ploughing time
- Presence of certain weeds e.g. cough grass.
- Source of power.

5.

- When the land steep
- Lack of skill to operate the disc plough
- When capital is inadequate to acquire disc plough
- When it is cost effective to use a jembe
- When there is adequate time.
- Where the land is rocky/stony.

6. (a)

- Kills soil organisms.
- Leads to loss of nutrients.
- Destroys soil organic matter.
- Leads to accumulation of some nutrients to toxic levels e.g. potassium.

(b)

- Control weeds/control pests and diseases
- Incorporate organic matter in the soil
- Improve soil physical conditions/attain appropriate tilt

- To make seedbed appropriate for growing certain crops e.g. in ridging.

(c)

- Saves time/reduce cost of production.
- Maintain soil structure
- Minimizes soil erosion.
- Minimizes root/tubers disturbance.
- Less laborious/conserves soil moisture.

7.

- Use of heavy machinery/implements when soil is wet.
- Continuous shallow cultivation.

8. **Maintenance practices of a plough**

- Cleaning after work
- Storing under shed
- Tightening loose nuts and bolts
- Replacing worn out parts/ repair broken parts.
- Greasing moving / rotating parts
- Oiling / painting for long storage.

9. **Destroy soil organisms**

- Loss of soil nutrients / loss of soil fertility.
- Accumulation of some nutrients to toxic level e.g. potash.
- Destruction of organic matter by oxidation / burning.

10. **Reasons for secondary cultivation**

- Control weeds

- Control pests and diseases
- Incorporates organic matter in the soil
- Improves physical condition / form required tilth
- Make appropriate tilth for planting certain crops e.g. ridging, rolling, leveling.

**11. Benefits of minimum tillage**

- Saves time and costs of production.
- Maintains soil structure
- Minimizes soil erosion.
- Less laborious
- Conserves moisture
- Minimizes root damage.

**12. i)**

- Cost / expenses / when distance is short
- Availability of skilled worker.

**13.**

- Disc harrow / rotavators
- Spring tine harrow / rigid tine harrow / ox – tine harrow.
- Spike toothed / peg – toothed harrow
- Chain harrow / zigzag harrow

**14. Application of herbicides.**

- Use of mulch / timely cultivation
- Use of cover crops
- Uprooting / slashing / grazing to control weeds

## WATER SUPPLY IRRIGATION

1.

- Transporting in containers.
- Piping / use of channels.

2. Dams/ ponds, Tanks / containers

3.

- Draining the land / Any method of drainage.
- Growing water tolerant crop e.g. rice
- Ridging / making furrows.

4.

- Boiling water / filtration
- Use or chemicals / chlorination / alum / soda ash
- Aeration of water / sedimentation.

5. a) Dams / weirs tanks / containers

b)

- Piping / use of pipes
- Use of channels
- Use of containers by vehicles , animals

6.

- Centrifugal / rotor dynamic pump.

- Reciprocating / piston pump
- Semi – rotary pump
- Hydram pump / hydraulic ram.
- Rotary pump / hydraulic ram.

7.

- Quantity of the material / durability.
- Size of the pipe / diameter / length
- Working pressure / thickness of the wall.
- Colour of the pipe of the pipe.

8. a)

- Type of soil
- Type of crop to be grown
- Source of water / quality of water
- Size of land to be irrigated
- Capital available / topography of land
- Profitability / viability of the enterprise.

b)

- Water is evenly distributed over the required area
- Less water is used / it more water economical.
- Causes less soil erosion in sloppy areas compared to surface irrigation
- Leveling of land is not necessary
- Help to clean the plant for ease of transpiration / photosynthesis.

- Soluble fertilizers can be applied with irrigation water more easily than in surface irrigation.

c)

- Use of sprinkler
- Use of hose pipes
- Use of watering cans.

**9.**

- Quality of material used for making the pipes / durability / resistance to rodent attack.
- Size of pipes i.e. diameter / length.
- Working pressure of the pipe / thickness of the pipe wall.
- Colour of the pipe.

**10.**

- Centrifugal motor dynamic pumps
- Piston / reciprocating pump
- Semi rotary/Hydrant
- Rotary pump.

**11. Uses of water**

- For diluting / mixing chemicals used to control pests, diseases, weeds for watering livestock e.g. drinking.
- Watering plants e.g. irrigation
- In processing farm produce e.g. coffee, carrot hides.
- Domestic use e.g. drinking cooking

- For rearing fish.
- Mixing concrete in construction
- Recreation e.g. swimming pooling.
- Cooking and running machine engines water treatment plant and process.

**12. a)**

- To remove bad smell/taste from water thus makes it fit for human consumption.
- To kill disease causing organism that thrive in dirty water.
- To remove solid particles/impurities.
- To remove excess chemicals e.g. fluorine/that may cause hardness in water.

**b)**

- For diluting/mixing chemicals e.g. pesticides.
- Acaricides, herbicides, fungicides.
- For watering livestock.
- For irrigation/watering crops.
- For processing farm produce e.g. hides, coffee, carrots.
- For washing farm tools equipment and farm structures e.g. animal houses.
- For domestic use e.g. cooking, drinking, sewerage disposal.
- For rearing fish.
- Mixing concrete/mortar in construction.
- Recreation purposes e.g. swimming pools.
- For cooling/running machines

**c)**

**Stage I: Filtration at intake:** Water is made to pass through a series of sieves.



Sieves trap large solid impurities.

**Stage II softening of water** Soda ash (sodium hydrogen carbonate is added into the water).

**Stage II coagulation and sedimentation** Alum/aluminum sulphate is added into the water. Alum facilitates coagulation and sedimentation of solid.

**Stage iv , filtration** Water is passed through a filtration tank, that removes all solid impurities.

**State v; chlorination** Small amounts of chlorine solution is added to the water chlorine kills pathogens disease causing organisms.

**Stage vi storage** Treated water is stored in clean tanks before use/distribution.

13.

- Size of the farm
- Type of enterprises in the farm
- Source of water
- Method of conveyance of water

15.

- It is water economical
- Can use water under low pressure
- Does not encourage fungal diseases
- Discourage growth of weeds between the crop rows

16.

- Repair/ replace worn out parts
- Regular cleaning
- Regular painting to prevent rusting

17. **The water treatment process**

**Stage 1. Filtration of an intake**

Water is made to pass through a series of sieves where large particles of impurities are trapped

**Stage 2 Softening of water**

Water is let to circulate in a tank (open) and mixed with soda ash to soften it

**Stage 3 Coagulation and sedimentation**

Alum is added to water to facilitate sedimentation and coagulation. Water stays here for 36 hours

**Stage 4 Filtration**

Water passes into infiltration tank where all the remaining solid particles are removed.

**Stage 5 Chlorination**

Filtered water enters chlorination tank where a small amount of chlorine is added to kill disease agents.

**Stage 6. Storage**

Treated water is stored before entering distribution channels for use.

**18.**

- Furrow irrigation/ corrugate irrigation
- Basin irrigation/ flood irrigation

**19.**

- Open ditches
- Underground perforated pipes
- French drains
- Cambered beds/ pumping water
- Breaking hard pans/ sub- soiling

**20.** (a) Dams/ weirs/ streams/ river ponds/ lakes

(b)

- Kill pathogens
- Remove sediments
- Remove bad smell/ taste
- Remove chemical impurities

**21. Reasons for water treatment**

- To remove bad smell and taste
- To kill harmful micro-organisms which thrive in dirty water e.g. bacteria.
- To remove solid particles e.g. soil, sand sticks
- To remove excess chemical impurities e.g. fluorides to soften water

# **SOIL FERTILITY**

## **1. Benefits of farm yard manure**

- Improves soil structure/ water holding capacity
- Supplies more than one plant nutrient
- Longer residual effect
- Promotes microbial activities in the soil
- Locally available
- Imparts a dark colour to the soil which help in temperature regulation
- Buffers soil PH/ improves cation exchange capacity

## 2.(a)

- Ability of a soil to produce and sustain high crop yields continuously by providing adequate moisture, nutrients, oxygen, space and freedom from pests and diseases damage.

## (b)

- Adequate depth
- Enough aeration
- Adequate moisture
- Sufficient nutrients
- Freedom from pests and diseases

3. (a)

(i)

- Foundation materials e.g. maize stalks accept material that occur in abundance
- Kitchen refuse, leaves
- Farm yard manure/ any well rotten manure
- Ash/ potassic fertilizer
- Top soil
- Leaves cover/ trash

**(ii) Importance**

- Provide source of micro- organism
- Enrich the manure with K and P.3
- Provide food for micro- organism that bring about decay

(b) (i) Sharp pointed stick checks the temperature of the manure during its formation to avoid over heating

(ii) Prevent entry of too much water causing water logging, poor decomposition and leaching of nutrients.

4. (a)

(i) A- Pit method

B- Heap system

(ii)

- Drainage/ free draining soils on site

- Type of soil
- Topography/ slope should be gentle

5.

A crop is grown and then ploughed and incorporated into the soil while it is still green

7. (a)

- Farm yard manure (FYM) improves soil structure/ improves soils water holding capacity.
- Supplies a variety of plant nutrients
- Has a longer residual effect
- Promotes microbial activities in the soil
- It is locally/ easily available
- Moderates the soil pH/ increases cation exchange capacity

(b)

- Species of animal from which the waste is collected
- Food material eaten by the animal
- Material used as bedding
- Method of storage of the FYM
- Age of the animal which produces the waste matter
- Age of the farm yard manure.

(c)

- It is bulky hence difficult to apply/ laborious/ difficult to store/ handle
- It has less nutrients per given volume
- May spread weed seeds
- May spread crop diseases e.g. black scurf in potatoes
- Releases nutrients slowly

8.

- Leaching/ soil erosion
- Plant uptake
- Volatilization/ burning/ denitrification

9.

- Leaching/ soil erosion
- Change of soil pH
- Burning of land/ volatilization/ denitrification/ accumulation of salts
- Fixation of nutrients/ nitrogen lock up
- Uptake by plants/ weeds/ continuous cropping
- Soil capping/ formation of hard pan
- Presence of soil – borne pests/ monocropping

10.

- Rapid growth rate
- Production of abundant foliage
- Rich in plant nutrients/ leguminous/ rich in nitrogen
- Ability to decay quickly
- Adaptable to wide range of conditions/ hardy.

#### 11.

- Method of storage
- Degree of decomposition
- Type of organic matter used
- Presence/ absence of non – biodegradable materials
- Amount and type of inorganic fertilizers added.

#### 12.

- Appropriate depth
- Proper drainage/ good water infiltration
- Well aerated/ good water holding capacity
- Adequate nutrients/ correct pH
- Free from excessive infestation of soil borne pests and diseases.

#### 13.

- Cultivation along the slopes/ across contours/ along river banks
- Continuous cropping with annual crops



- Pulverization of soil due to over- cultivation
- Burning of vegetation/ overgrazing

**14.**

- Improves soil structure
- Reduces leaching
- Improves water holding capacity
- Increases microbial activities
- Increases cation exchange capacity
- Improves nutrient status upon decomposition
- Burning of vegetation/ overgrazing

## **LIVESTOCK PRODUCTION (COMMON BREEDS)**

1.

(i) Dromedary *camelus dromedaries*

- Can stay for long periods without water
- Can withstand extremes of temperature
- Able to eat dry feeds
- It has thick hide and deep layer of subcutaneous which insulates in against effect of radiant heat
- Feet have large surface area which enable it walk on sand without sinking

(iii) **Characteristics of indigenous cattle**

- More resistant to tick borne diseases/ trop diseases
- Can withstand high temperatures
- Can survive on poor quality pastures
- Can walk long distance in search of pasture and water
- Have lower feed and water intake

(iv) **Features of exotic beef cattle**

- Blocky/ square/ rectangular in shape
- Low set/ short legs
- A fleshy body
- Thick neck
- Smaller udders

**3. (i) Jersey verses Friesian**

- Jersey requires less food.
- Jersey are more tolerant to heat.
- Jersey can survive on poorer pastures.

**ii. Characteristics of goats that adopt them rid areas**

- Good foragers hence survive on poor pastures.
- Ability to eat dry feeds
- Heat tolerant tissues.

**iii. Ways of improving indigenous cattle production.**

- Cross breeding with exotic breeds with superior characteristics.
- Supplementary feeding.
- Proper control/prevention of livestock diseases.

1 (i) Jersey

(ii) Friesian

**4.**

- Are more resistant to tick-borne diseases/tropical diseases.
- Can withstand high temperature.
- Can survive on poor quality pastures
- Can walk for long distances in search of pasture and water.
- HAVE lower feed and water requirement.
- Layers/Broilers/Dual purpose

# **AGRICULTURAL ECONOMICS**

## **1. The four types of records that a farmer should keep**

- Field operations records.
- Production records
- Consumable goods inventory.
- Permanent goods inventory.
- If there is no inventory records.
- Market records
- Labour records
- Breeding records.
- Breeding records
- Benefits of labour

## **2. Reasons for keeping health record**

- For use in selection and culling of animals on health grounds.
- Help to detect theft on the farm
- Help in planning and making sound decision
- Provide information for income tax assessment
- Help to determine how creditworthy is a farmer.
- Shows the assets and liabilities of the farmer
- Determine the value of the farms.
- Used in comparing performance between' enterprises/seasons/different farms.
- Help to solve disputes on the farm.
- Provide a history of the farm

- Help to determine terminal help trace history of diseases for better approach in treatment.
- Show when to vaccinate, deworm.
- Show costs on health of the animals in assessing/no fat ability of animals.

### **3: Conditions under which opportunity cost is zero**

Where there are no alternative enterprises to choose from/competing for resources available

This is the value of foregone best alternative/choice. When resources are free/unlimited.

9. If there is no choice. When resources are free/unlimited.

## SOIL FERTILITY II- INORGANIC FERTILIZERS

1.

They are highly soluble water/ easily leached/ no residual

Have a scorching/ burning effect on crops

They are highly volatile

2.

5 kg of  $K_2O$  is contained in 100kg of 25: 10:5

Therefore 400kg of fertilizer contains  $\frac{400 \times 5}{100} = 20\text{kg}$

100

3.

Help in Carbohydrate formation and translocation/plays role in plant metabolism

Assists in uptake of Nitrates from the soil

Imparts disease resistance to crops

Strengthens straws of cereals

Formation of chlorophyll

Help neutralization of organic acids in plants.

4.

- Lodging in crops/ weak stems
- Scorching of leaf tips and margins.
- Chlorosis.
- Premature leaf fall.
- Mottling/brownish spots on leaves

- Stunted growth.

5.

- Leaching
- Plant uptake.
- Volatilization/burning

6. (a)

- Needed in protein synthesis.
- Hastens vegetative growth in crops.
- A constituent of the chlorophyll molecule
- Increases the size of cereal grain
- Regulates the availability of phosphorous and potassium.
- Improves succulence in crops.

(b)

- Chlorosis of leaves
- Stunted growth.
- Premature ripening of crops.
- Premature leaf fall
- Formation of purple pigments.

7.

- Lodging? Weak stems? over succulence of stems
- Scorching of leaves
- Delayed maturity.

- Excessive foliage growth.
- Cause blossom end rot in tomatoes

**8.**

- Amino acids/protein synthesis
- Increase oil content and hormones
- Needed in formation of chlorophyll.
- Aid in Nitrogen fixation in legumes
- Needed in carbohydrates metabolism.

**9.**

Leave have purple pigmentation

Stunted growth

Poor root development

Lodging/weak stems in cereals

Poor seed and fruit formation

**10.**

- Broadcasting
- Foliar application
- Side/row/basal application
- Fertigation
- Hole placement/drilling

**11. a)**

Macro nutrients are required by the plants in relatively large quantities, but macro nutrients are required in small quantities



b)

- Elongation of apices of roots and shoot,
- Strengthens plant cell wall
- Help in protein formation
- Help in formation of the middle lamella
- Used in cell division



## **CROP PRODUCTION- PLANTING**

1.

- Early maturity of the crop
- Plant assumes desired shape and size.
- Possible to obtain two or more varieties of oranges on one root stock
- Highly yielding.
- Maintains parental genetic characteristics.
- Possible to propagate seedless e.g orange varieties.

2. (a)

- Seed economical
- Easy to achieve correct spacing
- Make subsequent operations easy

b)

- To obtain optimum plant population/efficient land use.
- Avoid competition for resources.
- Control spread of pests and diseases.
- Makes subsequent operations easy/easy to mechanize.

3.

- Soil moisture content
- Seed size.
- Soil type.
- Type of germination
- Soil moisture content

- Soil fertility.
- Machinery to be used.
- Intended use of the crop.
- Growth habit
- Prevalence of pests and diseases.
- Cropping system used.

4.

- To enable the crop to smoothens.
- For maximum utilization of seasons rainfall.
- Enable the crop evade serious attack by pests and diseases.
- Enable maximum utilization of available nutrients before they are leached.
- Reduced competition for labour.
- To get good market price.

5.

- To improve Nitrogen fixation in the roots of legumes

6.

- Highly yield.
- Eases control of weeds/pests/diseases.
- Aids in soil and water conservation.

7.

- Variety of maize
- Method of planting
- Purpose of the crop.

- Soil fertility
- Soil moisture content
- Number of seeds per hole.
- Use of machinery in subsequent operations

**8.**

- Rainfall pattern/reliability.
- Variety of beans
- Incidence of pests and diseases attack.
- Expected harvesting time.

**9.**

- To obtain high yield.
- Reduce pest/disease /weed attack
- To ensure high germination percentage,
- To obtain high quality produce.
- To obtain high quality produce.
- To obtain seeds suitable to the particular area.

**10.**

- Fertility status of the soil
- Use moisture content.
- Use to which the crop is to be put, machinery to be used.
- Growth habit of the crop/variety
- Number of seeds per hole.
- Prevalence of certain diseases, pests

- Crop stands either pure or mixed.

**10.**

- Intensive land use.
- Control soil erosion.
- Reduce cost of production
- Ensure early pasture establishment.

**11. (a)**

- Induces lodging
- Difficult to carry out field operations.
- Reduced yields.
- Low quality produced/ small cobs.

(b)

$$1 \text{ ha} = 10,000\text{m}^2$$

$$1\text{m} \times 0.5\text{m}$$

$$= 20,000 \text{ plants/ha}$$

**12.**

- Thinning
- Gapping

**13.**

- Free from pest/ disease attack
- Resistant to diseases
- High yielding

- Has high quality produce
- High rooting ability
- Early maturing

**15.**

- Rainfall availability
- Incidence of pests and diseases
- Expected weather conditions during harvesting
- Market demand of the crop
- Type of soil

**16.**

- Uses higher seed rate
- Not easy to use machines
- Not easy to establish the right population
- Overcrowding in some areas
- Uneven germination
- Difficulty to carry out field practices

**17.**

- Soil type
- Soil moisture content
- Size of seeds
- Type of germination

**18.**

- Enable the crop to withstand competition from weeds

- Enable the crop to escape attack by pests and diseases
- To better utilization of nutrients in the soil
- For better utilization of available rainfall
- To get good market
- To reduce competition for labour
- To time harvesting to occur during appropriate weather conditions



## **CROP PRODUCTION – NURSERY PRACTICES**

1.

(i) Reduce competition/ ensure healthy seedlings

(ii) Prepare the seedlings for the harsh conditions expected in the field

2.

Removal of the shade

Reduce the frequency of watering

3.

- Free from pest/ diseases
- Resistant to diseases
- Adaptable to different soil pH
- Can withstand water logging
- Compatible with several scions

4.

- Requires less skills to establish
- Easier to prune
- Higher yielding in the early years of bearing
- Does not allow accumulation of CBD due to frequent removal of old stems
- Comes to bearing earlier

## **CROP PRODUCTION – FIELD PRACTICES**

1.

- Allow adequate light penetration into the plant
- Improve quality of the fruits
- Reduce incidence of pest and disease attack
- Enable effective use of chemical sprays
- Facilities easy harvesting

2.

- To prevent sprouting
- Reduce pest attack
- To prevent fungal diseases/ rotting

3. (a)

- Facilitates field practices e.g spraying and harvesting
- Improves the quality of crops by preventing soiling
- Enable crop grow in the required direction
- To improve yield
- To control pests and diseases

(b)

Passion fruits, tomatoes, cucumber, grapes, tea, pumpkin, water melons,

Bougain vellia, garden peas, yams, gourds, indeterminate beans, roses, money

plant, hops, okra

4.

- Moisture content of grains

- Colour of leaves and grains
- Intended use of the crop

5.

- Improves soil aeration upon decomposition
- Reduce toxicity of plant poisons upon decomposition
- Reduce soil erosion
- On decomposition it improves soil structure
- Modify the soil temperature
- Add nutrients on decomposition
- Improves water infiltration
- Increases microbial activity
- Control weeds
- Reduces evaporation of water
- Buffer soil pH upon decomposition

6.

- Reduce run - off thus increase soil moisture
- Reduce evaporation thus maintaining high moisture in the soil

7. (a) Growing of different types of crops on the same piece of land following orderly sequence.

(b)

- Ensure maximum utilization of nutrients
- Control soil – borne pests and diseases
- Control weed

- Add nitrates into the soil
- Control soil erosion
- Improve soil structure

(c)

- Deep rooted crops alternate with shallow rooted ones
- Crop easily weeded are alternated with those difficult to weed
- Crops of the same family should not succeed each other
- Heavy feeders should come first in the cycle
- Include a legume crop

## **CROP PRODUCTION V- VEGETABLES**

### **1. (a)**

- Irregular watering of the crop/ water stress
- Excess application of Nitrogen in early stages
- Deficiency of element calcium in young fruits

### **2. (a)**

- Regular watering
- Addition of calcium into the soil
- Mulching

### **(b)**

- Regular watering
- Addition of calcium into the soil
- Mulching
- Avoid excess Nitrogen in the soil

### **(c)**

- Size of fruits
- Degree of ripeness
- Damage of tomatoes
- Shape of fruits

## **LIVESTOCK HEALTH – INTRODUCTION**

### **3. (a)**

- They have a longer productive life
- Produce high quality produce
- They are less expensive to keep
- They are high yielding
- Do not spread diseases others/ man
- They breed regularly

### **2 (b)**

- Foot and mouth diseases
- Anthrax
- Rinder pest
- Lumpy skirt disease
- Rabigs

### **3.**

- Prevent deficiency disease
- Improves animals and ability to resist diseases

### **4.**

- General farm hygiene/ cleanliness of houses. Feed/ water trough – W proper carcass
- Disposal; to destroy pathogens

- Isolation; prevents spread of the diseases
- Drenching; to control internal parasites
- Treat sick animals; prevent spread of the diseases
- Vaccination; develop resistance against diseases.
- Control vectors, prevent transmission of diseases
- Prophylaxis; avoids infection
- Slaughtering en- mass; prevent spread of diseases
- Proper breeding; control breeding diseases
- Quarantine; avoid spread of the diseases
- Hoof trimming; minimize occurrence of foot rot
- Proper housing; avoid predisposing causes of diseases

5.

- Through vectors/ external parasites
- Ingesting contaminated feed, water, milk
- Inhaling contaminated air
- Through surgical and instrument e.g. scalpels, needles, docking knife etc
- Mating
- Suckling young ones

## LIVESTOCK HEALTH – PARASITES

### 2. (a) (i)

- Red water ( Babesiasis)
- Gall sickness ( Anaplasmosis)

### (ii)

- East Coast Fever (ECF) Theileriosis
- Red water ( Babesiasis)
- Nairobi sheep disease
- Texas fever

### (b) Two hosts

### 2. (a)

- Anaemia
- Irritation/ scratching
- Loss of hair
- Wounds on skin
- Presence of parasites on the body

### (b)

- Regular drenching
- Rotational grazing
- Drain swampy areas
- Use of latrines by farm workers
- Use appropriate chemicals on swampy areas/ sue  $\text{CuSO}_4$  solution
- Burn heavily infested pastures



- Plough infested pastures
- Peripheral fencing
- Use of ducks on snail

(c)

- (i) Pig
- (ii) Fresh water snail

3.

- Larvae climbs on host
- Larva feed on 1<sup>st</sup> host
- Larva drop on the ground and moults into a nymph
- Nymph climbs – onto 2<sup>nd</sup> host
- Nymph feeds on 2<sup>nd</sup> host
- Nymph drops on the ground and moult into an adult
- Adult climb on 3<sup>rd</sup> host
- Adults feeds and mate on 3<sup>rd</sup> host
- Mated, engorged female drops and lay eggs on the ground
- Egg hatches into larvae

4.

- Burning infested pastures
- Hand picking and killing of ticks
- Rotational grazing
- Double fencing of pastures
- Zero grazing

- Ploughing infested pastures

5.

- Proper meat inspection
- Proper disposal of infested carcass
- Routine deworming of livestock/ human beings pets
- Rotational grazing
- Proper use of latrines
- Proper cooking of meat
- Burning/ ploughing infested pastures

## LIVESTOCK HEALTH – NUTRITION

1.

- Production ration is the feed given to an animal over and above maintenance level in order to produce a given product

2.

- Water soluble vitamins
- Fat soluble vitamins

3.

- Size of the animal
- Level of production
- Type of feed eaten
- Ambient temperature
- Physiological status of the animal
- Species of the animal

4.

(a) Roughage is a feed with high fibre content and low energy content; while concentrates is a feed with high protein/ energy content and low fibre content

(b)

- Synthesis/ formation of various products e.g. milk, meat
- Foetal development

- For work. Provide draft energy
- Growth

4.

- Bulky
- Low digestibility
- Low in energy/ protein content
- Highly fibrous
- Plant origin

5.

- Raw materials for synthesis of livestock products e.g milk, eggs
- Growth of cells
- Production of energy
- Formation of enzymes. Hormones and antibodies
- Repair of worn out tissues

6.

- Body weight/ size
- Age of the animal
- Work done
- Level of production
- Physiological condition e.g. pregnancy
- Weather conditions ambient temperature

7.

- A component of milk

- Formation of the skeleton / teeth
- Blood clotting
- Nerve functioning/ control milk fever

**8.**

- Nutrient requirement of the animal
- Age of the animal
- Type of animal whether ruminant or non- ruminant
- Availability of feedstuffs
- Cost of the food stuffs

**10. (a)**

- Production ration is the feed given to an animal over and above maintenance level in order to produce a given product

**(b)**

- Body weight/ size
- Age of the animal
- Work done
- Level of induction
- Physiological condition e.g. pregnancy
- Weather conditions/ ambient temperature

**11.**

- Provide energy/ maintenance of body temperature
- For growth and repair of body tissues

- For maintenance of good health
- Production of various products
- Enhance reproduction

# **LIVESTOCK PRODUCTION (III)–SELECTION &**

## **BREEDING**

1.

By concentrating genes from the parents to the offspring's

2.

- Reddening and swelling of the vulva
- Clear mucus discharge from the vulva
- Frequent bellowing
- Cow mount others
- Cow stands still when mounted by others
- Cow becomes restless
- Slight rise in body temperature
- Slight drop in milk in lactating cows
- Loss of appetite urinating frequently

3.

- It is uneconomical to keep a bull
- May lead to uncontrolled mating
- High risk of transmission of breeding diseases
- Only a small number of cows can be served

4. Mating of two unrelated animals of the same breed

5. (a)

(i) A- Oviduct/ fallopian tube

B- Ovary

C- Uterus

D – Vagina

(ii) A – passage of Ova from the ovary to the uterus

-Site of fertilization

B – Production of ova

Production of female sex hormones

(b)

(i) Artificial insemination

(ii) Natural method

(c) 19 – 23 days/ 3 weeks

Increased ability and performance of the offsprings above the average of the parents

7.

- Should be of age/ mature S – 7 months old/ 90 – 100kg live weight
- Good mothering ability
- Able to grow fast
- Good conformation
- With no physical defects
- Healthy
- Has 12- 14 teats
- Highly prolific
- Able to withstand heat stress during mating



**8.**

- (i) Mating closely related animals e.g brother and sister
  - (ii) Mating unrelated animals but within the same
- (b)
- (i) Harmful traits/ diseases can spread fast
  - (ii) Requires trained personal/ skills
  - (iii) Laborious
  - (iv) Low chance of conception due to poor timing/ death of sperms,
- (c)
- Good body conformation/ wedge shaped
  - Docile/ mild temperament
  - Her ancestors should have a record of high milk production
  - Free from physical deformities
  - Good health
  - Good size/ weight for the breed

## **LIVESTOCK PRODUCTION (IV) – REARING PRACTICES**

1.

- He goats
- Male calves
- Rams

2.

- Bad smell
- Overheating
- Lack of food/ water
- Sick/ infertile queen
- Attack by predators/ destruction of brood
- Too much noise

3. J (i) Docking/ Tailing

(ii)

- To facilitate mating/ to ease mating
- To control blow fly attack
- To ensure uniform distribution of fat

(iii) 1-2 weeks after birth

(iv)

- Use of elastrators and rubber ring
- Use of sharp knife
- Use of a docking iron

(v) Hoof trimming

(vi) The animal would become lame

Foot rot may develop

(vii) In a sitting position facing away from the person shearing

4. To make the bees less aggressive

5.

- Old age
- Low fertility
- Difficult in furrowing
- Less milk production
- Passing undesirable characteristics to its young ones
- Poor hearth
- Poor mothering ability

6. (a) Thick yellow secreted by the mammary glands within the first week after giving birth

(b)

- Has a laxative value that helps to cleanse the bowels
- Rich in antibiotics that confers artificial immunity
- Highly nutritious is necessary for fast growth) of the calf
- It is highly digestible, hence appropriate for the underdeveloped calf's digestive system

(c)

- Bucket feeding/ Artificial feeding
- Natural method/ calf sucks the dam

6.

- Restlessness
- Loss of appetite
- Swelling of vulva
- Udder enlarges
- Mucus discharge from the vulva
- Presence of colostrums in the teats
- Relaxation of ligaments on either side of the pelvic bones
- Cow isolate herself

7.

- To make them docile
- To improve growth rate
- Control breeding diseases
- To prevent inbreeding
- To control breeding
- To improve meat quality

8.

- Highly palatable
- Has high digestibility
- Rich in nutrients

9.

- Prevent the bees from absconding
- To avail food during time of seed scarcity

- To attract bees into a new hive
- To encourage multiplication of bees
- To ease access of feed

**10.**

- Proper feeding
- Control internal parasites
- Control external parasites
- Vaccination
- Zugging/burlying
- Hoof trimming
- Provision of adequate clean water
- Treat in case of infection

**12.**

- Routine feeding
- Application of manure/ fertilizer
- Cropping
- Maintenance of water flow/ changing the water regularly
- Control of predators

**13.**

- Restless
- Loss of appetite
- Udder/ teats enlarge
- Present of milk in the teats 24hrs before farrowing

- Vulva enlarges
- Muscle on either side of the tail/ pelvic bones slackens
- Sow prepares a nest

**14.**

- During drought/ when there are no flowers
- In case of a new colony
- When the colony is small/ to encourage fast multiplication

**15.**

- Deworming
- Flushing
- Crutching/ ringing/ cutting wool around reproductive organs
- Riddling
- Wiggling/ cutting wool around the face

**16.**

- Catfish
- Tilapia
- Trout
- Carps
- Bass
- Tench
- Blue gill
- Nile perch

# **FARM STRUCTURES**

## **1.**

- (i) 0.5m/50cm
- (ii) To prevent dampness
- (iii) To allow proper lighting
- (iv)
  - Nearness to the milking shed
  - Well drained area/topography.
  - Soil type
  - Security
  - Wind direction

## **2.**

- It is cheap
- It is attractive
- It is easily available
- Easy to work with

## **3. Siting**

- Should be near the homestead for security
- Should be in an accessibility place
- Sheltered from strong wind
- A well drained area
- On the leeward side of the farm house
- Where there is large space for possible expansion in future

### **Selection of building materials**

- Use easily available materials
- Choose durable materials
- Consider the cost of the material
- Consider the skills needed to work with the materials
- Materials to choose from; iron sheets, wire mesh off cuts, timber, concrete

### **Requirement of the hutch**

- Should be leak proof
- Should be well ventilate
- Should be free from draught
- Should be easy to clean
- Should have raised floor
- Floor should allow free drainage

3.

- To prevent warping/ bending / twisting
- To prevent rotting/ damage by fungi
- To prevent it from pest attack
- To enable timber to achieve it maximum strength

4.

**Advantage:** It's more effective in preventing animals from forcing their way through the fence

**Disadvantage:** It's more expensive than plain wire

The bars may cause injury to the animal/ destroy wool.



**5.**

- Allows air circulation in the house
- Controls temperature in the house
- Prevent humid condition inside the house

**7.** 1 cement, 3 and, 4 ballast/ gravel

(b) 1/ cement

(c)

- It is durable
- It is fire proof
- It is easy to clean
- Can be moulded into various shapes

**9.**

- Should be raised from the ground
- Should be leak proof
- Should be easy to clean
- Should be well ventilated
- Should be rat proof/ vermin proof
- Should be easy to load/ offload
- Strong enough, spacious

**10.**

- Reduces incident of accident when using them
- Ensure efficient usage of the structure

- To increase its durability
- To give high re- sale value of the structure

**10.**

- Topography/ drainage
- Accessibility of the pen
- Wind direction
- Direction of the sun
- Security of the calf
- Location of existing, structure/ amenities
- Space for future expansion

(b)

- Strength/ durability of the material
- Cost of the material
- Availability of the material
- Availability of capital
- Workability/ skills required in using the material
- Type of pens ( permanent/ temporary)
- Climate of the area
- Safety of the calf

(c)

- Repair/ replace worn out/ broken parts
- Clean the pen regularly
- Ensure drainage system is working

- White wash the walls

**11.**

- Partial burning/ charring of the posts
- Cut the top in a sloping manner
- Cover the top with a plastic/ metal sheet
- Reinforce with concrete

**12.**

- Well ventilated
- Easy to clean
- Leak proof
- Well drained floor
- Draught free
- Spacious
- Well lit

**13.**

- Repair/ replace broken parts
- Regular cleaning to remove dirt
- Dust/fumigate/ spray to control parasites and diseases
- Apply old engine oil on timber parts
- Ensure good drainage around the house
- Maintain a footbath at the entrance

**14.**

- It is more durable

- Its stronger
- Its fire resistant
- Its not attacked by vermin's

**15. (a)**

- Provide security from thieves, predators
- Enable paddocking/ rotational grazing/ mixed farming
- Control parasites and diseases by keeping away foreign animals
- Show boundaries between farms
- Hedges act as wind breaks
- Have an aesthetic value
- Hedges help to conserve soil and water
- Hedges may be source of fruits/ fodder/ firewood
- Provides privacy
- Enables isolation of animals for different purposes

**(b)**

- Wind direction
- Soil type
- Security
- Accessibility of the structure
- Location in relation to existing structure
- Topography/ drainage
- Government policy/ regulations
- Purpose of the structure

- Position of the sun
- Proximity to social amenities
- Space for future expansion
- Farmers tastes and preference

**16. Adds beauty to the farm**

- Source of firewood
- Source of fodder/ mulch material
- Serves as a wind break
- Control soil erosion
- Controls animal/ human movement
- Provides security/ privacy
- Mark farm boundaries

**17.**

- Top bars can easily be removed and replaced when inspecting the combs
- Easy to construct
- Ensure high quality honey
- Easy to harvest
- Help to avoid mass killing of bees
- Possible to exclude the queen from the honey combs

**18.**

- Paint metal tanks
- Regular washing of the tank
- Repair any leakage

**19. (a)**

- **Claw hammer;** for driving in and out nails from wood
- **Tape measure;** to measure the required sizes of timber
- **Tin snip;** for cutting iron sheets for roofing
- **Clamp/ sash camp;** for holding tightly together pieces of wood when cutting/ joining
- **Handsaw;** for putting timber to the required size
- **Wood chisel/ Brace/ hand drill;** for boring holes in wood
- **Mallet;** for hitting the chisel when boring holes
- **Pliers;** for cutting wires
- **Jack plane;** For smoothing timber surface
- **Marking/ mortise gauge;** for marking points for cutting / planning on timber
- **Ball pen hammer;** for straightening/ shaping metal sheet
- **Try square/ combination square;** for determining right angles on cutting points of timber

**(b)**

- Clear the site to be fenced
- Use a string to layout the fence line
- Determine the position of posts using a tape measure
- Dig the holes using a hole digger/ claw bar
- Use a ruler to determine the right hole depth
- Obtain the right length of the posts using a tape measure
- Obtain the posts to the required depth using a handsaw

- Put concrete at the bottom of the hole
- Place the posts in the holes
- Ensure posts are vertical/ right angles
- Fill up the hole with soil/ concrete
- Firm the soil/ concrete in the hole using a ramming rod
- Heap soil/ concrete at the base of post

**20.**

- It is more expensive
- It requires a lot of skills to work with
- Prone to rusting
- Its not easily available
- Its heavy and difficult to transport

## **SOIL AND WATER CONSERVATION**

1.

- Reduce the speed of water hence erosive ability
- Trap soil being carried by moving water
- Increase infiltration of water hence reduce surface run-off

2.

- Reduce the volume of run-off due to increased infiltration
- Acts as windbreakers
- Reduce the impact of raindrops on the soil
- Tree roots bind the soil particles together reducing its erodibility
- Reduce the impact of raindrops on the soil
- Reduce speed of run-off
- Improve soil structures thus reducing the erodibility of soil

3.

- To prevent loss of plant nutrients
- To maintain good soil structures

4.

- Reduce the speed of run-off thus lowering the erosive power of water
- Reduce impact of raindrops thus reducing splash erosion
- Cover the soil protecting it from wind erosion
- Grass roots bind the soil particles together reducing the erodibility of soil
- Reduce speed of run-off, thus reducing the erosive power of water



- Organic matter from grass improves soil structure thus reducing erodibility of the soil
5. – Reduce evaporation
- Reduce surface run- off
6. (a) Afforestation is the practice of growing trees in areas where they had not existed,
- (b) Re- afforestation is the practice of growing trees where they have been harvested.
- 6.
- Topography of the area
  - Rainfall intensity/ amount
  - Type of soil
  - Soil depth
  - Vegetation cover
  - Farming practices

## WEEDS AND WEED CONTROL

1.

- Prevents weeds from establishing in the field
- Prevent allelopathic effects of weeds
- Reduce the cost of crop production
- Reduce multiplication and spread of the weeds
- Reduce spread of pests/ diseases for which weeds acts as alternate hosts
- Reduce competition between weeds and the crop
- Avoid contamination of crop with weed seeds
- Prevent injury to the farmer/ livestock

2.

- Uprooting
- Cultivation
- Mulching
- Application of herbicides
- Slashing

3. (i) G – Couch grass (*digitaria sealarum*)

H- Sodom Apple (*solanum incarium*)

(ii)

- Compete for resource with cultivated crops
- It increases the cost of crop production
- Lowers the quality of pastures

(iii) It has deep underground structures difficult to remove

#### 4. 2001 Disadvantages of weeds

- Compete for resources with crops
- Increase the cost of crop production
- Some may contaminate the crop lowering the quality.
- Irritate the workers lowering labour efficiency.
- Some weeds are parasitic to crop pests and diseases
- Some weeds are allelopathic.

#### 4.:

- Produce large quantities of seeds
- Seeds remain viable for along time
- They have effective mechanisms of dispersal
- Some weeds have the ability to propagate both by seeds and vegetatively.
- They have elaborate root system.
- Some have underground structures difficult to control.
- Some are able to survive with limited nutrients.
- Some are able to compress their life cycle.
- Some weeds are allelopathic.

#### 6.:

- (i) Thorn apple (*Datura stramonium*)
- (ii) Annual weed
- (ii) Poisonous if eaten

## **LAND TENURE AND REFORMS**

1.

- Difficult to control pests and diseases/diseases and parasites spread faster.
- Land disputes are common
- No motivation to conserve land
- No motivation to make long term investments
- An individual cannot use land as security to acquire
- Difficult to control breeding in livestock.

2.

- Saves time and money
- Makes it easy to have a sound farm plan e.g rotation programme.
- Eases soil conservation.
- Eases supervision as all enterprises are at one place.
- Facilitate mechanization.

3.

- To settle the landless.
- To ease population pressure.
- To increase agricultural production.
- To improve people's standard of living.

4.

- Communal tenure
- Co-operative tenure

## **PESTS AND DISEASE CONTROL**

1.

(i) Weaver bird

(ii)

- By eating the grains
- Opening the cab to water that leads to rotting of the grains,

(iii)

- Use of scare crows
- Trapping
- Use of explosives
- Use of resistant varieties

2.

(i) Cutworm/Agrotis

(ii) Cuts the stern causing lodging.

- Use of appropriate insecticide.
- Removing it and killing it.

3.

- Its cheap
- Saves on labour.
- Does not cause environmental pollution.

4.

- Destroy the alternate host
- Practice crop trapping.
- Destroy the crop remains

5.

- Seed dressing using appropriate chemical.
- Use of resistant varieties
- Practice close season.
- Practice field hygiene/destroy crop residual.

6.

- Concentration of the pesticide
- Weather condition during and soon after application
- Stage of development of the pest.
- Persistence of the pesticide.
- Formulation of the pesticide.
- Mode of action of the pesticide.

(a)

- Biting and chewing
- Piercing and sucking

(b)

- Store hygiene/ensure store is clean
- Proper drying of grains.
- Ensure store has proper ventilation.
- Keep store airtight.
- Clear the bush around the granary.

## 8

- Proper plant nutrition, increase disease resistance/control deficiency diseases.
- Crop rotation breaks life cycle of pathogens
- Rogueing, prevent further spread of the disease.
- Use of disease free planting materials: prevents introduction of pathogens in the field.
- Close season breaks the life cycle of pathogens.
- Timely /early planting; help crop to establish early before attack.
- Proper spacing; creates unfavorable conditions for some pathogens.
- Weed control; eliminate weeds that could be alternate hosts for particular pathogens.
- Resistant varieties; ensure crop is not attacked by the pathogen.
- Use of clean equipment/tools, prevent spreading of the disease from one plant to the other.
- Quarantine; prevent spread of the pathogen from one farm to the other.
- Heat treatment; kills the pathogen.
- Pruning; creates unfavorable microclimate for some pathogens/prevent spread of the disease.
- Destroy crop residue; kills the pathogen.
- Control the vectors, prevent further spread of pathogens.

## 9.

- Plant resistant varieties
- Practice crop rotation.



- Practice field hygiene.
- Use of clean planting materials.
- Trim roots of suckers before planting.
- Plant Mexican marigold close to the banana plants.

**10.**

(a) Point at which damage on a crop by pest is beyond tolerance and has to be controlled.

(b)

- By contact
- Through ingestion
- By suffocation

(c)

- Pesticides are expensive.
- Pesticides requires special skills to handle. They are poisonous/environmental hazard.
- Some are non-selective/they kill useful organisms.
- Some pest develop resistance to the pesticide.

**11.**

- Lower the quality of farm produce.
- Lower they yield.
- Increase cost of production
- Some pests are vetors of crop diseases.
- Some pest lower labour efficiency by irritation.

12.

- Early planting
- Rogueing
- Trap cropping

13.

- Attack by nematodes.
- Root nodules due to nitrogen fixing bacteria.

## **FIELD PRACTICES (II)**

1.

- Field birds; *accept any appropriate example.*
- Shoot fly;
- Stem borers.
- Diseases; Rust, Downy mildew, Ergot, smut

2.

- The crop has well developed roots to absorb the nitrogen before it can be lost
- Maize is growing fast and requires a lot of nitrogen.

3. Head smut/smut

4.

- Putting rat guards/ ensures granary is vermin proof.
- Ensure store is clean.
- Clear the vegetation around the granary.
- Harvest the grains on time to prevent attack in the field.
- Proper drying of grains.

- Use rat traps
- Use of cats.

5.

- Weevils,
- Flour beetles,
- Lesser grain borer;
- Greater grain borer;
- Khapra beetle;
- Warehouse moth;
- Saw toothed grain beetle;
- Angoumois grain moth.

(i) K, G, H, J

(ii) Failure of boll to develop

(iii)

- Do not pick the lint when it is wet
- Pick on weekly bases
- Avoid dry twigs or leaves contaminating the cotton
- Do not use sisal bags to hold cotton as the sisal fibres may contaminate lint,

(iv)

- Cotton lint
- Cotton seed

6.

- Early/ timely planting
- Practice crop rotation
- Practice field hygiene
- Destroy crop residue
- Practice roguing
- Use healthy / certified seeds
- Practice close season
- Use appropriate pesticide to control the vector
- Uproot volunteer crop

7. (i)

- Field hygiene/ destroy crop residue/ roguing
- Use of trap crop
- Destroy alternate host/ weeds
- Timely harvesting

(ii)

- Stalk borers
- Armyworms
- Aphids
- Dusty brown beetles
- Weevils
- Termites
- Locusts

- Leaf hoppers/ grasshoppers
- Cystic beetle
- Great/ lesser grain borer; cut worms
- American bollworms

**9.**

- Uprooting weeds cultivation
- Mulching; t application of herbicides
- Slashing/ cutting the weeds

**10.**

- Control the vector
- Use certified seeds
- Use of resistant varieties
- Practice field hygiene
- Early planting
- Rogueing
- Practice close season

## FORAGE CROPS

1.

- Mixed pasture is more nutritious
- Economies on nitrogenous fertilizers by N- fixation
- There's higher yield per unit area
- There is security incase of failure of one crop
- It provides a good soil cover hence control erosion
- There is maximum utilization of soil nutrients

3.

- Leads to exhaustion of pasture crop
- May lead to high incidence of parasites and diseases
- Leads to soil erosion

4.

- To raise the carbohydrate level for proper fermentation
- To increase the nutrient level of silage
- To increase the palatability of silage
- To restrict growth of undesirable microorganisms

4. (a)

- (i) Under- sowing is the establishment of a pasture crop under a nurse crop
- (ii) Over- sowing is the establishment of a high quality pasture crop on an existing grass pasture

(b)

- Slashing/ moving

- Uprooting
- Use of selective herbicides

(c)

- Replenish soil nutrients
- Hasten growth/ increase herbage yield
- Improve the nutritive value of the crop
- Amend soil physical and chemical properties
- Enhance decomposition of organic matter by micro-organism/ increase microbial activity

5.

- Rotational grazing/ controlled grazing
- Proper stocking rate
- Conserve excess pasture
- Timely defoliation
- Practice zero grazing
- Graze different classes/ species of animals

6.

- Stage of growth at harvesting time
- Species of the forage crop used
- Duration of storage
- Soil fertility where the crop was grown
- Weather conditions during drying
- Length of drying period

- Pest/ disease attack on the crop
- Method of storage

## 8.

- There is intensive/ efficient use of land
- Reduces the cost of forage production
- Control soil erosion due to ground cover
- Ensure early pasture establishment

### 8. (i) Seedbed preparation

- Practice early seedbed preparation/ during the dry period
- Clear all the vegetation/ stumps
- Carry out primary tillage
- Dig deeply to remove all weeds/ perennial weeds
- Carry out secondary tillage
- Seedbed should have a medium tilth
- Prepare furrow/ holes for planting
- Spacing between furrows 90- 100cm for cuttings/ 90 – 100cm x 50cm for splits

### (ii) Planting

- Plant at the onset of the rains/ early planting
- Select desirable Napier grass variety for the ecology of the area
- Use healthy planting materials
- Use cuttings/ canes or splits for planting
- Cutting/ canes should have 3-5 nodes
- Select cutting from mature canes/ stems



- Place planting materials in the furrows/ holes
- Cover the material with soil to the appropriate depth

**(iii) Fertilizer application**

- Apply phosphate fertilizer at planting
- Apply farm yard manure/ composite manure before planting
- Rate of organic manure should be 7 – 10 tons/ ha
- Apply organic manure after harvesting and dig it into the soil every year
- Top dress with Nitrogen and potassium 6-8 weeks after planting

**(iv) Weed control**

- Control weeds by; cultivation, uprooting, slashing, selective/ appropriate herbicides, intercropping with legumes that smother the weeds
- Practice timely weed control

**(v) Utilization**

- Cut and feed it to ruminants.
- Defoliate/ cut at the right stage of growth/ 3 - 5 months old/ when stems are 1 – 1.5 m high
- Cut the stems at 2.5 – 5 cm above the ground surface
- Use sharp panga for cutting
- Conserve excess as silage
- Chop Napier grass into small pieces before feeding
- Napier grass can be dried and used as mulch

9. (a)

- Lucerne, silver/ green leaf, desmodium siratro, stylo

(b)

- Reduce build- up of parasites and diseases
- Animal waste is evenly distributed in the fields
- Excess pastures can be conserved
- It is easy to carryout management practice
- Pasture is given time to regenerate
- Pasture is maximally utilized

(c)

- Sprinkling some water
- Reduce compaction
- Fill the silo and seal it from air rapidly

10.

- Control soil erosion
- Ensure adequate pasture for animals
- Increases the useful life of the pasture crop

11. (a) Practice of coating legume seeds with a nitro- culture/ rhizobium bacteria

(b) Growing a legume pastures over an existing grass pasture

## **LIVESTOCK HEALTH (III)**

1. Oral ( mouth), broken skin ( wounds), nasal, ocular ( eyes), anal, ears, reproductive organs, umbilical cord
2.
  - Routine vaccination
  - Slaughtering all infected animals
  - Impose quarantine
  - Treatment of wounds
3.
  - Difficult in breathing/ respiratory problem
  - Dullness/ birds stands with eyes closed
  - Anorexia/ loss of appetite
  - Nasal discharge
  - Sneezing
  - Droopy wings
  - Yellow/ greenish watery diarrhoea
  - Drop in production
  - Soft- shelled eggs
  - Torticollis/ bending of neck
4.
  - Wounds on the udder/ teats
  - High milk production
  - Very old cows

- Unhygienic handling of the cow
- Poor udder placement/ pendulous udder
- Incomplete milking
- Genetic factors
- Early and late lactation period
- Poor milking technique

5.

- Blood/ pus in milk
- Painful udder/ teat/ animal kicks when teats are touched
- Swollen/ inflamed udder
- Clots/ thick milk
- Watery milk
- Blocked teat canals
- Drop in milk production
- Foyer

6.

- Anthrax
- Rinderpest
- Foot and mouth
- Lumpy skin disease

7.

- Routine vaccination
- Isolate infected birds/ kill all infected birds

- Disinfect the poultry house before introducing a new stock
- Obtain chicks from reliable sources
- Imposition of quarantine

**8. (i) Fowl pox**

- May lead to death of the birds
- Farmer incur extra expenses in its control

(ii)

- Kill and dispose off all infected birds
- Routine vaccination
- Control biting parasites
- Treat wounds

**9.**

- Wounds in infected hooves
- Foul smell from infected hooves
- Spend most of the time lying if both hind legs are infected
- Grazes when kneeling if fore legs are infected
- Loss of appetite
- Lameness/ limping
- Swelling of infected hooves
- Emaciation

**10. (i) Protozoa/ coccidia/ Eimeria species**

(ii) Bacterium/ clostridium spp/ clostridium chauvei

**11. (i)**

- Long hooves
- Damp environment/ poor hygiene
- Injury on hooves

**(ii)**

- Anaemia
- Fever
- Constipation
- Lack of appetite/ anorexia
- Inability to move
- Reduced milk production
- Animal becomes aggressive

**12.**

- General farm hygiene to kill the pathogens
- Isolate sick animals to prevent spread of the disease
- Deworm the animals to control endo-parasite
- Treat the sick animals to prevent spread of the disease
- Vaccinate the animals to develop resistance against disease attack
- Control vectors to prevent spread of the disease
- Routine administration of drugs/ prophylaxis to prevent infection
- Proper feeding to prevent deficiency / nutritional diseases

- Mass slaughter of infected animals to prevent spread of diseases
- Proper selection and breeding to control breeding and inheritable diseases
- Proper housing to avoid predisposing animal to diseases
- Foot trimming to minimize occurrence of foot rot disease
- Imposition of quarantine to prevent spread of diseases

**13.**

- Lack of stiffness of the carcass/ lack of rigor mortis
- Production of tar- like watery blood from all body openings
- Extensive bloating

**14. (a) Bacterium/ *Brucella abortus***

(b)

- Spontaneous abortion/ premature birth
- Retention of after birth abortion
- Bareness
- Yellowish brown slimy odourless discharge from the vulva

(c)

- Use artificial insemination
- Cull infected animals
- Vaccinate all young animal
- Avoid direct contact with aborted foetus/ after birth
- Observe hygiene/ proper disposal of aborted foetus

**15.**

- Routine vaccination
- Improve quarantine
- Kill and dispose off infected animals
- Isolate sick animals
- Disinfect the animal house

**16.**

- Swollen lymph nodes
- High fever
- Profuse salivation
- Lachrymation/ production of tear
- Difficulty in breathing
- Bleeding in the vulva and mouth
- Coughing

**17. (a) Deficiency of calcium in the wood of the cow**

- Muscular twitching
- Staggering as the animal moves
- Animal become unconscious
- Loss of appetite
- Cessation of body functions
- Dullness
- Animal lies with the neck twisted for the head to lie on the shoulder



(c)

- Feed animal with diet rich in calcium
- Partial milking
- Intravenous injection with calcium salts/ calcium borogluconate

# **POULTRY PRODUCTION**

## **1.**

- Debeaking
- Making laying boxes/ nests dark
- Feeding on balanced diet
- Hanging green vegetation to keep birds busy scatter grains on the floor
- Isolating and treating cannibalized birds
- Control external parasites
- Keeping birds according to age/ avoid introducing new birds
- Provide adequate space

## **2.**

- Size/ weight/ volume of egg
- Colour
- Cleanliness
- Shell quality e.g. broken, rough
- Shape of the egg

## **3. (a)**

- Ensure brooder corners are rounded
- Provide enough brooding space accordingly. Clean and disinfect the brooder house/ equipment.
- Provide wood shavings/ proper litter on the floor
- Maintain appropriate temperature range according to the age of the chicks

- Temperature during the 1<sup>st</sup> one week should be 32 – 35<sup>0</sup> c, then reduce accordingly
- Spread sheets of papers and sprinkle chick mash on them
- Provide fire guard around the heat source
- Maintain proper ventilation by adjusting the openings
- Provide fresh, adequate and qualify feed/ chick mash
- Provide brooder with reliable and appropriate lighting/ dim light
- Provide adequate and appropriate waters/ feeders according to age/ number of chicks
- Remove dead chicks from the brooder
- Control parasites by applying appropriate pesticides
- Control diseases appropriately
- Isolate and treat sick chicks immediately
- Keep proper records
- Gradually change the feed in the last one week in the brooder
- Debeak 8 – 10 days towards the end of brooding
- Provide adequate clean water all the time

(b)

- Combs and wattles are small, dry and cold/ combs have white scales
- The space between the pelvic bones is narrow 2-3 fingers cannot fit in the space between the pelvic bones
- Plumage is shiny, well preened/ sometimes moulting
- Yellowish pigmentation in the vent, shanks and beak

- Space between the keel bone and pelvic bone is small / 3-4 fingers cannot fit in the space
- Eyes are dull and yellow
- Abdomen is hard
- The layer is lazy and dull
- Hen becomes broody

#### 4.

- Repair/ replace broken parts of the house
- Maintain a footbath at the door of the deep litter
- Clean and remove any dirt/ cob webs
- Fumigate against pests and diseases/ spraying/ dusting
- Paint some parts of the house/ apply old

#### 5.

- Dirt
- Abnormal size/ undersize/ oversize
- Irregular/ broken/ soft shell
- Internal abnormalities e.g. double yolk, meat spots, poor candling qualities
- Poor storage/ long storage beyond 5 days

#### 6.

- Ensure laying nets are dimly lit
- Provide adequate laying nests
- Debeak perpetual egg eaters
- Collect eggs regularly and frequently

- Ensure birds get a balanced diet
- Keep birds busy by hanging green vegetation in the house/ scatter grains on the liner.

**7. (a)**

- Chicks move away from heat source
- Parting/ opening beaks
- Opening the wings/ spreading wings
- Making abnormal noise
- Drinking water excessively
- Chicks may lie flat on their bellies

**(b)**

- Requires less space/ high stocking rate
- Less loss of eggs
- Easier collection of manure/ easier accumulation of manure
- Easier protection of birds from vermin's/ parasites/ diseases
- Less labour requirement/ easier to collect eggs/ easy handling
- Cheaper to set up than battery cage/ low initial cost

**8.**

- Should be fertilized
- Should be medium in size
- Should be oval in shape
- Should not be cracked
- Should be clean

- Should be free from abnormalities/ blood spots/ meat spots/ double yolk
- Should be 5 – 10 days old
- Should have smooth shell

9.

- Regularly wash and disinfect the feeders/ waterers/ perches
- Replace old wet litter/ turn litter regularly
- Control visitors into poultry house/ use of footbath before entering the house
- Avoid pouring water on the litter/ avoid dampness
- Isolate sick birds
- Treat sick birds
- Dispose of dead birds immediately

## LIVESTOCK PRODUCTION (vi)

### 1. (a)

K- Alveolus

L- Gland cistern

M – Teat cistern

N – Teat

### (b)

(i) Milk let down is the flow of milk from the upper/ alveolar region of the udder to the gland and teat cisterns

(ii) Oxytocin

### (c)

- Practice farm hygiene/ milk infested cows last/ use a separate udder towel for each cow/ use disposable udder towel
- Immediate treatment of infected cows to avoid spread of the diseases/ treat any wounds on the teat/ udder
- Practice teat dips after milking
- Applying milk salve/ jelly to prevent drying and cracking of teats
- Practice good milking techniques

### 2.

- Ensure calf is breathing/ administer artificial respiration.
- Clean mucus from the calf/ ensure cow licks the calf dry
- Cut and disinfect the umbilical cord
- Ensure calf sucks colostrums from the mother within the first 8 hours

- Feed the calf on colostrums for the first 4 days
- Keep records on the performance of the calf, introduce whole milk or milk replacer after the 4<sup>th</sup> day.
- Feed the calf with warm milk at regular intervals
- Feed the calf 2-3 times per day for the first 1 – 4 weeks
- Feed the correct amount of milk up to weaning
- Observe strict hygiene in calf
- Protect the calf against adverse weather conditions by providing proper housing
- Provide adequate clean water from the 3<sup>rd</sup> week
- Introduce palatable dry fed e.g. concentrates and good quality grass/ mineral salts from the 3<sup>rd</sup> week
- Keep calf in individual pens until it is 3-4 months old
- Spray / dip calf against external parasites
- Drench deworm calf against internal parasites
- Vaccinate the calf against prevalent diseases
- Release the calf from the pen occasionally for exercises
- Wean calf at 8 weeks/ 16 weeks
- Deworm the calf using appropriate methods
- Graze calf on good quality pastures ahead of adult cows
- Separate heifer calves at puberty to avoid in breeding
- Weigh the calf regularly
- Treat sick calves
- Put appropriate identification



- Defeat if necessary
- Change in feed be done gradually
- Serve at the right age/ weight/ 15 – 20 months/ 250- 280 kg

**3. (a)**

- Should be clean/ free from physical contamination
- Has the right consistency/ no water added/ true to the breed
- No strange odours/ no foul smell
- Free from diseases causing organisms
- White in colour/ normal colour/ not tainted
- Normal taste/ flavour

**(b)**

- The calf can be reared artificially even if a mother dies during birth
- Many calves can be reared at a time
- The calf can be given correct amount of milk
- It is possible to keep clear records on milk
- Yield

**4.**

- Free from diseases causing organisms
- Free from dirt/ foreign materials
- Appropriate smell and flavour
- Chemical composition within the expected standards

**5.**

(a) The milk secreted by the mammary glands within the first week of lactation/ thick yellow milk secreted by the mammary glands within the first week after parturition.

(b)

- Has a laxative and helps to remove the faecal meconium/ first faecal matter/ opens up the alimentary canal/ cleanse the digestive system/ prevent constipation
- It is rich in antibodies that offers temporary immunity against diseases
- It is rich digestible proteins/ fats/ minerals/ vitamin/ highly nutritious
- It is highly digestible

(c) Bucket feeding/ bottle feeding/ artificial method. Dam suckling the calf/ calf sucks the dam/ natural method

**6.**

- The milk person should be clean
- Test for mastitis before milking
- Milk person should be healthy
- Ensure utensils/ equipment are clean
- Ensure milking parlour is clean
- Ensure milking herd is free from zoonotic disease e.g. TB
- Cows with mastitis should be milked last

- Clean the udder
- Sieve the milk
- Cover the milk
- Avoid feeds/ weeds that would taint the milk just before milking
- Proper storage of milk/ cool, dry place.

7.

- Clean mucus from calf soon after birth/ ensure cow licks dry
- Ensure calf is breathing / administer artificial respiration
- Cut and disinfect the umbilical cord. Ensure calf sucks the mother to get colostrums, within the first 8 hours
- Feed the calf on colostrums for the first 4 days. Introduce whole milk/ milk replacer after 4 days
- Feed the calf with milk at body temperature
- Weigh the calf regularly
- Provide adequate clean water
- Introduce palatable solid feed e.g. concentrates, good quality grass from 3<sup>rd</sup> week
- Put appropriate identification marks
- Treat calf if sick
- Castrate male calf
- Provide proper housing for calf
- Keep calf individually up to the weaning time
- Control external parasite with appropriate method/ spray/ dip
- Drench/ deworm to control internal parasites

- Observe hygiene
- Remove extra teats
- Dehorn/ disband using appropriate method
- Release calf occasionally for exercises
- Keep records on calf performance
- Wean calf at 8 weeks/ 16 weeks
- Reduce amount of milk gradually towards weaning
- Train calf to take milk from a bucket.

## **FARM POWER AND MACHINERY**

### **1. (a)**

- It makes farm operations timely/ faster
- Economizes on labour
- Work is done more efficiently
- Reduces drudgery/ can accomplish heavy task
- Cheaper per unit work done in large
- Operations

### **(b)**

- Turns/ inverts the furrow slices thus covering surface vegetation
- Cuts the furrow slice horizontally
- Holds the frame on to the mould board land side and share
- Absorbs thrust exerted on the mould board to make the plough stable

### **(c)**

- Always clean after use
- Check the nuts and bolts and tighten if loose
- Repair broken parts
- Replace worn out parts/ lost parts
- Proper storage

### **2.**

- Reciprocating mower/ cutter bar mower
- Power take – off shaft
- Sharpen the cutting blades

- Tighten loose nuts and bolts
- Lubricate moving parts
- Repair broken parts
- Replace worn- out parts
- Clean after a days work
- Check the tension of the v- belt and adjust accordingly
- Coat with old engine oil for long storage

**3. (a)**

- Ox- drawn mould board is lighter hence does not compact the soil as much as the tractor – drawn mould board plough
- Ox – plough can be use for more farm operations e.g. weeding, ploughing harvesting roots crops than tractors mould board.
- Ox- plough requires less skills to operate compared to the tractor plough
- Tractor plough is faster than ox- plough hence can plough a large area with a short time
- Source of power for ox- plough is not as reliable as the source of power for tractor plough
- Ox- plough relatively shallow compared to tractor plough that plough deeper
- Ox- plough can be used in steeper lands where tractor plough cannot plough
- Ox- plough requires more people to operate than tractor plough
- Ox - plough is cheaper to buy than tractor plough
- Ox - plough is cheaper to maintain than tractor plough

(b)

- Grease the moving parts ( i.e. movable parts)
- Paint frame/ oil before long storage
- Tighten loose nuts and bolts
- Clean it after work
- Store in a shed
- Repair damage parts
- Replace worn- out parts

(c) **Advantages**

- It is cheaper
- Farmer does not incur maintenance costs of the tractor
- There is no risk of owing the tractor
- Farm operations are carried out faster

**Disadvantages**

- Tractor may not be available when required
- Some operators may charge high fees for the service
- Some operators can carry out poor quality work

4. (a)

- To reduce wear and tear/ increase durability
- Avoid rusting

(b)

- Sharpen blades if blunt
- Replace worn – out parts

- Clean the mower after use
- Tighten loose nuts and bolts
- Repair worn- out guard
- Paint when necessary
- Proper storage in shed

(c)

- Size of land
- Cost of the tractor
- Availability of services facilities/ availability of skilled labour e.g drivers, mechanics, spare parts
- Topography of the land
- Time available for the operation
- Availability of capital
- Number/ type of enterprises on the farm
- Availability of tractor hire services/ availability of other sources of power

**5. (a)**

- Incorporating manure into the soil/ stirring the soil
- Breaking soil clods
- Leveling the seed bed
- Covering broadcasted seeds
- Gathering/ removing trash

(b)

- Clean after use



- Store in a shed
- Repair/ replace any broken tine/ part
- Apply oil for long storage

(c)

- Ox- drawn harrow is cheaper than a tractor- drawn harrow
- Ox – drawn harrow can be used where tractor drawn harrows cannot be used

**6.**

- Clean after work storing in a shed
- Tighten loose nuts
- Replacing worn- out parts
- Greasing moving parts
- Oiling/ painting for long storage

**7. (a)**

- Decrease the angle of cut
- Use of hydraulic/ draught control lever
- Adding weights on the plough beam
- Raising the land wheel

(b)

- To avoid injury
- To make disc plough last longer
- To make disc plough work efficiently
- To reduce replacement/ maintenance cost

(c)

- Saves time
- Improves efficiency
- Saves on labour cost
- Reduces drudgery/ less tedious

**8. (a)**

- To make a vertical cut into the soil that separate the furrow slice from the unploughed land
- Cut trash which would prevent the share from penetrating deep into the soil

**(b)**

- Lubricate moving parts
- Adjust the tyre pressure
- Replace worn-out tyres
- Tighten loose nuts and bolts
- Proper storage/ in shed
- Clean after use
- Paint the trailer
- Repair broken parts

**9.**

- Poor quality work unless under strict supervision/ poor skill of the operator
- Not readily available leading to late land
- Preparation
- Disc harrow
- Spring tine harrow/ rigid tine harrow/ ox- tine harrow

- Spike toothed harrow/ peg toothed harrow
- Chain harrow
- Rotavator
- Zigzag harrows

**10. (a)**

- If a farmer has inadequate capital
- If a farmer has little load to carry
- If the area is too steep to use a tractor

**(b)**

- Tighten loose nuts and bolts
- Straighten bent/ repair worn out/ broken parts
- Store in a dry place
- Apply oil on exposed metal parts when plough is not in use
- Repaint the appropriate parts when necessary

## AGRICULTURE ECONOMIC III

### 1. (a)

- Training the labour force
- Giving incentives to employees
- Efficient supervision of labour
- Assigning specific tasks to workers
- Proper remuneration of a worker
- Provide efficient tools
- Mechanization of some operations
- Provide transport within the farm

(b)

This is the production in which each addition unit of input results to a larger increase in output than the proceeding unit of input

(c)

- Short term credit
- Medium term credit
- Long term credit

### 2. (a)

Opportunity cost is the value of foregone best alternative/ revenue foregone because of choosing the best alternative

(b)

Refers to the raw materials used up in the process of production, e.g. seeds, fuel fertilizer, feeds

(c)

Utility is the satisfaction one gets by using a commodity

**3. (a)**

- Borrowing from financial institutions/ individuals co-operative/ credit
- Person savings from ones income
- Inheritance/ gifts/ donations

(b)

- Assists the farmer in estimation of the required production resources
- Assists the farmer when negotiating for farm credit
- Assist the farmer in making management decisions when comparing alternative projects
- Help to reduce uncertainty in farming process
- Encouraging farmers to efficient as to meet the projected targets
- Show progress/ lack of progress in the farm business/ focus profit or foresee losses

**4. (a)** Fixed costs are those that do not change with the level of production while variables costs are those that change with level of production

(b)

- Casual labour costs
- Fertilizer/ manure costs
- Costs of chemicals
- Cost of fuel
- Costs of repair of machinery

- Cost of hiring machinery

(c)

- Planning helps in selection of the best enterprise/ production option to undertake
- Helps in setting production targets/ goals
- Helps in allocation of resources to various enterprises
- Helps to identify the weakness and strength of farm operations
- Helps in timely and careful considerations in decision making
- Assists in negotiation of credit
- Maximize use of resources

5.

- To compare the performance of one farm with another
- To compare the performance of the farm between one season and another
- To compare the contribution of one enterprise and another on the same farm
- Acts as a measure of profit in a farm

6. (a)

- Zone I. For each addition unit of fertilizer applied, the output of potatoes increases at an increasing rate because resources are under utilized
- Zone II. For each additional unit of fertilizer applied, the out put of potatoes increases at a decreasing rate as the resources are utilized to the maximum
- Zone III. For each additional unit of fertilizer applied the out put of potatoes decreases since the resource is excessively applied.

(b) Zone II

(c)

- Flexibility in production.
- Produce under contract
- Input rationing/appropriate allocation of resource input.
- Insurance of the crop.
- Use of modern technology e.g. disease resistant varieties,
- Use of pesticides and fungicides, use of fertilizers.

**6. (a)**

- Training/ educating labour force
- Mechanizing farm operations/proper working tools.
- Giving incentive/proper housing/transport bonuses.
- Supervision of labour
- Assign specific tasks to workers.
- Proper remuneration
- Assigning tasks according to skills/ability/interest.

(b)

- Improvement in quality of work/quality of produce.
- Reduced time of performing a given work.
- Increase in returns per unit of labour.

(c)

- Amount of work/ task performed e.g. kg of tea leaves picked per head.
- Duration of work e.g. 30/= per hour/day.

- Labour regulations/market rates
- Nature of work
- Quality of work/skill of labour

**8.**

- Amount of money to be paid to them as wages.
- Number of people in the labour market
- Health /fitness of the work force
- Ability/skills of the labour force
- Working conditions/incentives
- Nature of work

(b)

- Adopting modern methods of production
- Flexibility in production methods
- Input rationing
- Taking insurance cover
- Selecting more reliable enterprises
- Diversification.

(c)

- Provides employment
- Source of food
- Earns the country foreign exchange
- Source-of raw materials for industries
- Provide market for industrial goods



- Source of income for farmers
- Improves infrastructure relationship.

9.

- Maximize profit
- To maximize cost of production
- To spread/ reduce risks

10. (a)

- Milk and butter
- Beef and hide
- Honey and wax
- Mutton and wool
- Pork/bacon and bristles
- Rabbit meat and skin/pelts
- Mutton and skin

(b)

- Feeds
- Pesticide
- Replacement stock
- Veterinary services
- Drugs
- Casual labour
- Packing materials e.g trays and carton boxes

(c)

$$(i) V = \frac{48-39}{2-1} = 9$$

$$2-1$$

$$W = \frac{32-27}{4-3} = 5$$

$$4-3$$

$$X = \frac{23-21}{6-5} = 2$$

$$6-5$$

$$Y = \frac{20-19}{8-7} = 1$$

$$8-7$$

L.C.C occurs where MRS =

$$\text{L.C.C.} \quad \frac{X_1}{PX_2}$$

$$PX_2$$

Where  $\Delta$  = change

P = price

$X_1$  = dairy meal

$X_2$  = Home made feed

$$\frac{8}{2} = 4$$

$$2$$

L.C.C. is where  $MRS = 4$  I.E where 5 units of dairy meals are mixed with 23 units of home made feed.

**11. (a)**

- Joint products
  - Competitive products
  - Supplementary products
  - Complimentary products
- b) (i) Production function is the physical relationship between inputs and output (products). The quantity of product expected from a certain-combination of input.
- (ii) Equi-marginal returns states that limited amounts of resources should be allocated in such away that the marginal returns those resources is the same in all alternative to which they are put.

**12.**

- Crop boards/marketing board/statutory boards.
- Commercial banks
- Cooperative societies
- Agricultural finance corporation (A.F.C)
- Settlement fund trustees
- Private money lenders/Non –Governmental Organizations (NGOS ) insurance companies/ Hire purchase companies.

**13 a)**

- Costs of feeds

- Wages casual labour
- Cost of pesticide / chemicals/drugs
- Cost of insemination services

b)

- depreciation of machinery /buildings
- Land rent
- Salaries of regular/permanent labour
- Interest on borrowed capital

**14 (a)**

- Partial budget is prepared when minor changes are to be made in an enterprise
- Complete budget is spread when major changes are to be made in an enterprise/  
starting arrow enterprise.

b)

- Diversification of enterprises to avoid total loss
- Insurance against losses to maintain high liquidity/for compensation /to access  
money easily for any eventuality.
- Strategic farming/keeping crops produce and selling when prices are high.
- Flexible enterprises-engage in enterprises that can be stopped and changed
- Rationing of inputs use of insufficient inputs such that incase of failure losses are  
not too high.
- Contracting for marketing-making arrangements with marketing agencies in  
advance.

- Selection of more certain enterprises/ selection of enterprises that can do well in an area/section of enterprises with ready market and less price fluctuation to reduce degree of risk.

## **AGRICULTURE ECONOMICS- FARM INPUTS**

### **1. (a)**

- Journal
- Cash book
- Ledger
- Inventory

### **b)**

- Shows the assets and liabilities of the farm business,
- Shows farm net worth/net capital/ owners worth/ can be used to negotiate for credit/correct income tax assessment,
- Used in decision making;
- Show profit or loss.

# **AGRICULTURAL ECONOMICS (MARKETING & ORGANIZATION)**

1. -Ten members

(b)

- Number of sellers
- Price of the commodity
- Availability/ seasonally of the commodity / weather.
- Technique of production
- Market information
- Transportation
- Price expectations of the commodity.
- Government policy/taxation.

(c)

- Price fluctuations/ low prices
- Lack of transportation.
- perish ability of some products
- poor storage facilities.
- Competition with substitute products.
- Delayed payments
- Some government policy

(d)

- Kenya Planters Co-operative Union
- Coffee Board of Kenya.

- a) Marketing is the performed of business activities that direct the flow of goods and services from producers to consumers.
- b) An imperfect market is g situation in which some buyers, some setters or both have limited knowledge of goods and services offered for sale at various prices.
- c) The price of mangoes will go down.
- (d)
- Milk is highly perishable we hence needs cool storage which the farmer may not afford.
  - Lack of vehicles/poor roads/high transportation costs
  - Containers for handling milk are expensive.
  - Lack of market information
  - Price fluctuation.
  - Delayed payments.

2.

- a) The quantity of the product demanded varies inversely with the price 7 as the price declines the corresponding quantity demanded rises and as the price increases the corresponding quantity demanded falls. (Mark as a whole)
- Advertisements/ sales promotions
  - Price of related goods, price of the goods,
  - Level of income
  - Price expectations
  - Tastes and preferences.
  - Tastes and preferences



- Population,
- Religious beliefs / taboos.

(c)

- Elasticity of demand of a commodity is the percentage in quantity demanded of a commodity resulting from a percentage change in existing price.
- The degree of responsiveness of quantity demanded, to a- percentage change in existing price.
- Buy farmers produce / delegates buying to an approved agent
- Arrange for supply of inputs.
- Fix prices of farm produce in consultation with the government.
- Collect farm produce from areas of production to the stores/factories.
- Inspect the production process to ensure and maintain quality of the produce.
- Provide storage facilities for farmers produce.
- Provide credits to farmers,
- Provide technical advice on production/extension services where applicable
- Process farm produce e.g. K.T.D.A.
- Undertake research services on techniques of production
- Sell farm produce for farmers
- Regulate production to prevent under supply of the produce.
- Pack/package the farm produce.
- Invest accrues profits.
- Advertise/promote sales of the produce.

3.

- Members buy inputs at lower prices.
- Has easy access to credit facilities from the society.
- Gets advice/education from the society.
- Society share overhead costs with the member.
- Society share overhead costs with the member.
- Provide special services e.g. A.I, Banking
- Bar society bargains for better milk price on behalf of the member.

5.

- (i) Most agricultural produce are perishable hence, farmers incur extra costs in transportation-processing/storage/incur losses due to spoilage.
- Most of them are bulky, occupy large space/expensive to transport.
- Poor transport network/lack of vehicles lead to loss due to spoilage.
- Most of them are seasonal; hence create storage problems/over supply at times leading to price fluctuation.
- Due to bulkiness they are expensive to store/difficult to store.
- Due to changes in market demand, there is time e.g. between decision to produce and actual availability of the product making it difficult to respond immediately to market demand.
- Change in supply due to under/over production/competition from cheap imports cause price fluctuation.

- Lack of perfect market information makes selling difficult/many farmers are ignorant on the prevailing prices of their produce in other parts of the country.
- Delayed payments lead to lack of capital for farm operations.

(b)

- Itinerant traders/ middlemen buy and resell produce from farmers.
- Processors / Manufacturers buy and process produce from farmers.
- Wholesalers- Buy produce in bulk from farmers and resell/ process.
- Brokers / Commission agents- acts on behalf of other business people for a fee commission.
- Co-operative societies/ unions- buy farmers produce locally.
- Marketing boards- promote production and marketing of agricultural produce/buy produce from farmers.
- Retailers- buy from wholesalers and resell to consumers.

6.

- Price of related commodity.
- Price of the commodity.
- Size of population of consumers,
- Tastes and preference of consumers.
- Income of consumers.
- Advertisements/sales promotion
- Government policy
- Price expectations.
- Religious beliefs/religious taboos/ cultural beliefs.

7.

Elasticity of demand =  $\frac{\% \Delta \text{ in quantity}}{\% \Delta \text{ in price}}$

$\% \Delta \text{ in price}$

$\Delta \text{ in price quantity} = 22-20 = 2 \text{ bags}$

$\% \Delta \text{ in price} \Rightarrow \frac{22-20}{20} = 10\%$

20

$\Delta \text{ in price} = 100-800 = 200/=$

$\% \Delta \text{ in price} = \frac{200}{1000} \times 100 = 20\%$

1000

**Elasticity of demand =  $\frac{10\%}{20\%} = 0.5$**

**20%**

7. (a)

- Carrying out advertisement of the farm to increase demand
- Finance agricultural activities.
- Transportation of farm produce to areas of consumption.
- Storage of farm produce to minimize losses/ as a marketing strategy.
- Selling the produce on behalf of the farmers.
- Packing/package farm produce to ease transport/ reduce storage space.
- Grade farm produce to provide uniform standards/ cater for various consumers.
- Process farm produce from areas of production for bulking/ transportation
- Protect the farm produce from damage by use of chemicals/ insurance/ bear risks.

- Buy from produce from the producers.
  - Gather, analyze and interpret market information to determine appropriate market and price.
- b)
- Co-operators pool their resources together to buy expensive machinery e.g tractor for use by farmers.
  - Provide education/technical information to members.
  - Provide credits to members inform of inputs and cash.
  - Negotiate for higher produce prices for members.
  - Reduce overhead costs e.g transportation, storage and use of machinery.
  - Bargain with suppliers to give discount on seed fertilizer and other farm inputs /provide inputs at lower prices.
  - Provide employment for their members and other people.
  - Benefits farmers from lower taxes charged
  - Market farmers produce.
  - Provide strong bargaining power for members on policy issues.
  - Invests and pay dividends to members.
  - Help to negotiate loans for their members without security.
  - Provides banking services to it's members.

8.

- Perishability of the produce.
- Inadequate supply to spread supply over a long period.
- Drastic changes in supply/seasonality.

- Poor infrastructure e.g. poor roads no vehicles/piped water/ telephone / electricity,
- Bulkiness
- Lack of market information,
- Delayed payments.

2.

Mr. Rambo's farm balance sheet as at 31-12-95

ASSETS			LIABILITIES		
	Kshs	Cts		Kshs	Cts
Fixed			Long term		
Asset			Liabilities		
Buildings and structures	60000		Loan payable Dank	300,000	-
Five cows	250,000	=			=
400 layer	80,000	=			=
20 goats	30,000	=			=
Spray equipment	12,000	=			=
TOTAL	972,000				
Current			Current		
Assets			Liabilities		
Cattle feeds in store	10,000		Debts to co-p	20,000	=
Animal drugs in store	4,000	=	Bonus payable to workers	19,000	
Debts receivable	18,000	=	Breakages and repair	30,000	-
Cash at hand	20,000	=			
Cash at bank	30,000	-			
Total	82,000	=	Total	69,000	=
Total Assets	1,054,000		Total liabilities	369,000	
			Capital	685,000	
TOTAL	1054,000		TOTAL	1054,000	
ASSETS			LIABILITIES		

	Kshs	Cts		Kshs	Cts
Fixed			Long term		
Asset			Liabilities		
Buildings and structures	600000		Loan payable bank	300,000	-
Five cows	250,000	=			=
400 layer	80,000	=			=
20 goats	30,000	=			=
Spray equipment	12,000	=			=
TOTAL	972,000				
Current			Current		
Assets			Liabilities		
Cattle feeds in store	10,000		Debts to co-p	20,000	=
Animal drugs in store	4,000	=	Bonus payable to workers	19,000	
Debts receivable	18,000	=	Breakages and repair	30,000	-
Cash at hand	20,000	=			
Cash at bank	30,000	-			
Total	82,000	=	Total	69,000	=
Total Assets	1,054,000		Total liabilities	369,000	
			Capital	685,000	
TOTAL	1054,000		TOTAL	1054,000	



3.

(a) **Cash account;** is a record that shows all cash receipts and payments,

**Ledger:** This is a financial book that shows all financial transactions in the farm business in a summarized form,

**Balance sheet:** This is a financial statement that shows the value of assets and liabilities of a business at the end of an accounting period.

**Purchase order.** This is a financial document drawn by a buyer to a supplier requested goods on credit.

(b)

- Permanent goods inventor
- Consumable goods inventory.

5.

PROFIT AND LOSS ACCOUNT FOR MRS. MBUTA'S FARM FOR THE YEAR ENDED 31-12-03			
PURCHASES AND EXPENSES	Shs. Cts	SALES AND RECEIPTS (CREDITS)	Kshs. Ct
Opening valuation	6,000.00	Pig sales	7,000.00
Wages	5,000.00	Piglet sales	4,000.00
Equipment	8,000.00	Maize sales	3,000.00
Pig feeds	4,000.00	Closing valuation	4,000.00
Drugs	3,200.00		
		Total	18,000.00
		Loss	8,200.00

TOTAL	26,200,00		2,600.00
-------	-----------	--	----------

**Marks allocation**

- (i) Correct columns (sales & receipts) ½ mk
- (ii) Purchases & expenses ½ mk
- (iii) Correct entries – Sales & receipts – ½ mk  
Purchases & expenses – ½ mk
- (iv) Correct totals – sales & receipts – ½ mk
- (v) Purchases & expenses – ½ mk
- (vi) Correct balance / profit/ loss ½ mk  
3 ½ mk
- (vii) Mrs. Mbuta made loss

6. (a) it is an entry in a financial statement showing the worth of all assets of an enterprise at the beginning of an accounting period

(b) (i)

- Issued to the buyer as evidence of cash payments for goods or services rendered
- Used for requisition for the supply of goods/ services on credit
- Given to the buyer by the seller as evidence of goods supplied

# K.C.S.E AGRICULTURE PAPER 1

## SECTION A (30 marks)

*Answer all the questions in this section in the spaces provided*

1. Differentiate between Olericulture and pomoculture as used in crop production  
( 1 mk)
2. State three ways by which biological agents can enhance the process of soil formation  
( 1 ½ mk)
3. State four advantages of drip irrigation  
( 2 mks)
4. State four advantages of adding organic manure to a sandy soil  
( 2 mks)
5. State two factors that would determine the amount of fertilizer to be top dressed to a crop in the field  
( 1 mk)
6. State four advantages of applying lime as a measure of improving soil condition  
( 2 mks)
7. Give four reasons for using certified seeds for planting  
( 2 mks)
8. Give four reasons for planting crops at the correct spacing  
( 2 mks)
9. State three effects of soil erosion  
( 2 mks)
10. Name four methods used to control weeds in pastures  
( 2 mks)
11. State two benefits of conserving forage crops  
( 2 mks)
12. Mention four practices that should be carried out to maintain grass pasture  
( 1 ½ mks)
13. Define the following terms as used in agriculture economics  
(a) Gross domestic product (GDP) ( 1 ½ mks)

- (b) Per capita income ( ½ mks)
14. What is profit maximization in agriculture economics? ( ½ marks)
15. State four benefits of budgeting to a farm manager ( 2 mks)
16. Give two reasons why farmers keep farm accounts
17. State activities carried out by young farmers club in Kenya ( 2 mks)
18. State four ways by which afforestation helps in land reclamation ( 2 mks)
19. State three advantages of multiple stem pruning over single stem pruning in coffee ( 1 ½ mks)

**SECTION B (20 mks)**

*Answer ALL the questions in this section in the spaces provided*

20. Two maize pests are shown in the diagram below. Study them and answer the questions that follow,

s

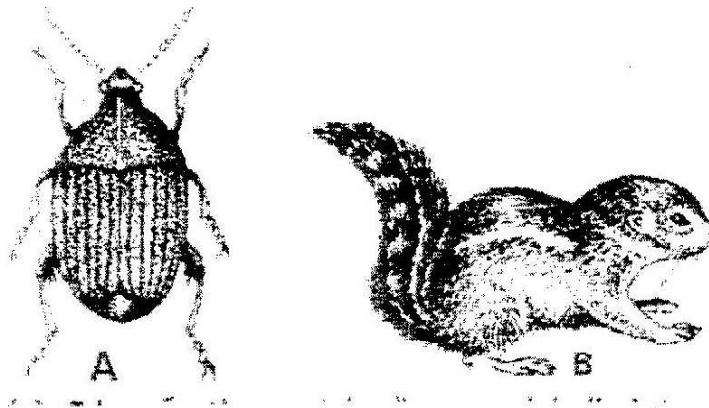

- (a) Identify the pests in the diagram labeled A and B ( 1 mk)
- (b) at what stage of maize production does each damage the crop?
- (c) Give one way of controlling each of the pests in the field

21 (a) state the law of diminishing returns in a production process

(b) Use the information on the table below to answer the questions that follow

Fertilizer input ( units)	Maize yield (bags)	Marginal productions (bags)
0	50	12
1	62	12
2	66	4
3	68	2
4	69	1
5	69	0

The cost of fertilizer is Kshs 1500 per unit and the price of maize is Kshs 1200 per bag.

- (i) At what unit of fertilizer input should the farmer be advised to stop applying any more fertilizer to the maize? ( 1mk)
- (ii) Give a reason for your answer in (b) above
- (iii) Calculate the marginal return at the point of optimum production ( 1mk)

22. (a) Describe the procedure which should be followed in spraying a crop in tomatoes using a fungicide in powder form, water and a knapsack sprayer. (3mks)

- (b) Name one fungal disease of tomatoes that can be controlled using the above procedure. (1mks)
- c) State four safety measures that should be taken while spraying the crop with the fungicide. (2mks)

23. The diagram below shows a weed



- a) Identify the weed (1mk)
- b) State two reasons for controlling the weed. (2mks)
- c) Name two herbicides that can be used to control the weed in a field of maize (1mk)
- d) At what stage of growth of maize should the weed be controlled using a post emergence herbicide?

**SECTION C (40 MARKS)**

*Answer any TWO questions in this section in the spaces provided at the end of the section.*

24. Describe the establishment of kales under the following sub – headings:
- a) Nursery preparation
  - b) Establishment in the nursery
  - c) Management of seedlings in the nursery.
  - d) Transplanting of seedlings.
25. a) Outline the factors necessary for proper functioning of farmers’ co-operative societies in Kenya. (5mks)
- b) Explain how farmers overcome risks and uncertainties in a farming business.
  - c) Describe the steps farmers should follow when planning a farm business
26. a) List various methods of harvesting water in a farm
- b) Outline farming activities which may encourage soil erosion.
  - c) Explain how various farming practices would help to conserve soil in a farm.

**K.C.S.E. PAPER 2**

**SECTION A (30 MARKS)**

*Answer ALL the questions in this section in the spaces provided.*

1. Name a breed of sheep with a Lambing percentage of above 125 and whose fleece may be inferior due to black fibres. (1mk)
2. List two appropriate hand tools needed to finish off the handle of a fork-jembe. (1mk)
3. What is “cropping” in fish farming? (1mk)
4. State four functions of lubrication system in a tractor. (2mks)
5. Give four maintenance practices carried out on the water cooling system of a tractor. (2mks)
6. State reasons why a farmer would choose to use a disc plough rather than a mould board plough. (2mks)
7. State four construction features necessary in a fish pond. (2mks)
8. Give four ways in which disease causing organisms can gain access into a newly born calf (2mks)
9. State four ways of controlling tsetse flies. (2mks)
10. Give two predisposing factors of foot-rot in sheep. (1mk)
11. State four factors which should be considered when selecting dairy goats for breeding. (2mks)
12. Give four reasons why camels are suited to living in arid areas. (2mks)
13. Name two functions of the crop in the digestive system of chicken. (1mk)
14. State four methods of dehorning (2mks)



15. Mention six causes of stress to a flock of layers. (3mks)
16. State four functions of the worker bees in a bee colony. (2mks)
17. State four features of a good pig house. (2mks)

**SECTION B (20 MARKS)**

*Answer ALL the questions in this section in the spaces provided.*

18. (a) A diagram of a planter is shown below. Study it and answer the questions that follow.

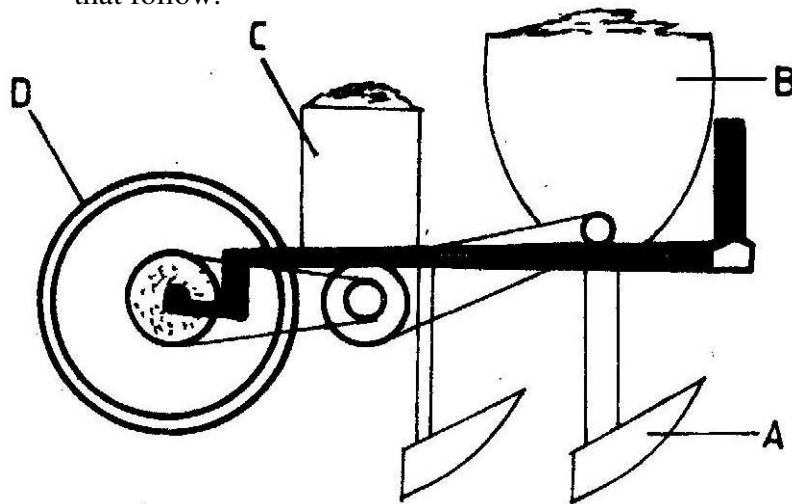

(i) Identify the parts labelled A, B, C, and D, (2mks)

A \_\_\_\_\_

B \_\_\_\_\_

C \_\_\_\_\_

D \_\_\_\_\_

(ii) State two maintenance practices carried out on the planter. (2mks)

b) Study the diagrams of workshop tools shown below



(i) Identify the tools labeled E and F (1mk)

E \_\_\_\_\_

F \_\_\_\_\_

(ii) What functional advantage does tool E have over tool F? (1mk)

19. The diagram below represents a calf pen. Study the diagram and answer the questions that follow.

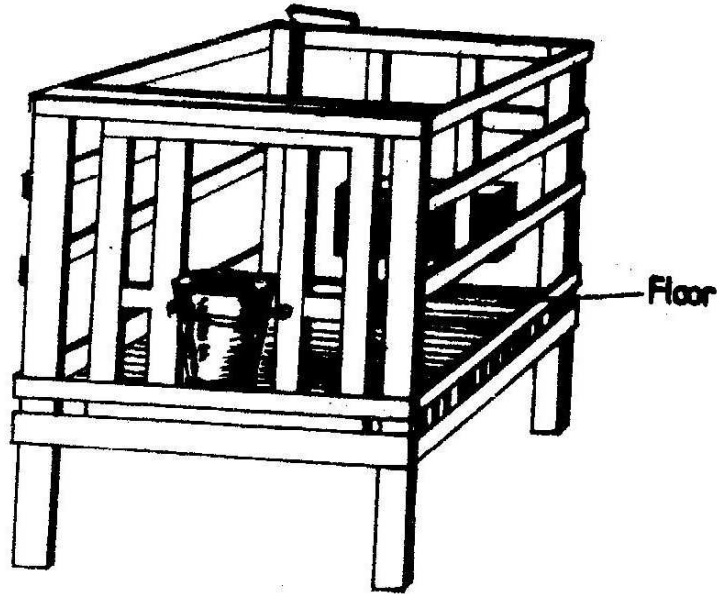

- (a) (i) Identify the type of floor. (½ mk)
- (ii) How high should the floor be raised above the ground level? (1mk)
- (b) (i) Give one reason for having the floor of the calf pen raised. (1mk)

(ii) State three factors that should be considered in sitting the calf pen.  
(3mks)

20. (a) Define the term digestible Crude Protein (DCP) (½ mk)

(b) A farmer wanted to prepare a 200kg of calf rearing ration containing 20% DCP. Using the Pears Square Method, calculate the amount of Maize containing 10% DCP and Sunflower containing 35% DCP the farmer would need to prepare the ration. (Show your work) (4mks)

21. A diagram of a cow is shown below. Study it and answer the questions that follow.

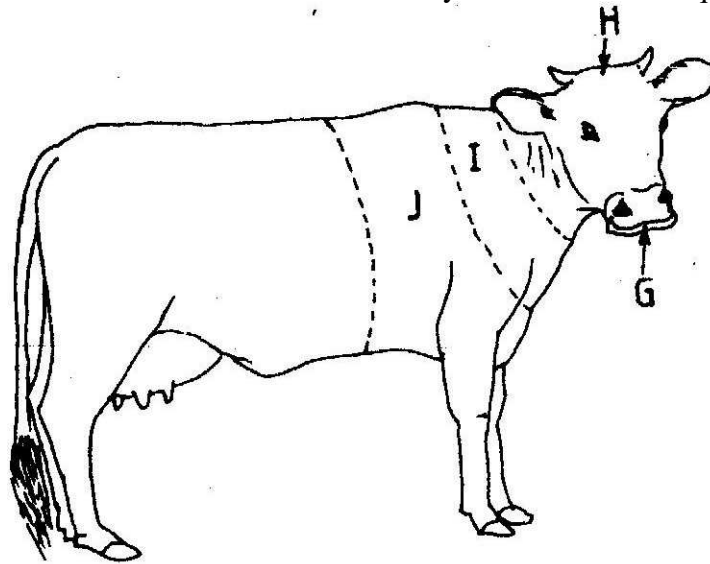

(a) Name the parts labeled G, H, I and J.

G \_\_\_\_\_

H \_\_\_\_\_

I \_\_\_\_\_

J \_\_\_\_\_

(b) Name four parts of the animal preferred by a two host tick. (2mks)

**SECTION C (40 MARKS)**

*Answer any TWO questions in this section in the spaces provided at the end of the section.*

22. a) Outline the procedure followed when hand spraying cattle to ensure effective use of acaricides to control ticks. (10mks)
- b) Discuss Foot and Mouth disease under the following headings:
- (i) Casual organisms. (1mk)
  - (ii) Livestock species attacked. (2mks)
  - (iii) Symptoms of attack. (4mks)
  - (iv) Control measures. (3mks)
23. a) Describe the management practices that a farmer should carry out to improve milk production in a low yielding herd of dairy cattle. (15mks)
- b) Describe the management practices that would ensure maximum yield of fish in a fish pond. (5mks)
24. a) What are the advantages of farm mechanization? (6mks)
- b) Explain the differences between a two stroke and a four stroke cycle engine. (6mks)
- c) Outline the daily maintenance practices that should be carried out on a farm tractor (8mks)

## K.C.S.E AGRICULTURE PAPER 1 MARKING SCHEME

### SECTION A

1. Olericulture is growing of vegetables while pomocuhure is growing of fruits

(Mark as whole)

1mk

2.

- Movements of animals in large numbers
- Decomposition of plants and animals remains by soil micro-organism
- Physical breaking of rocks by roots of higher plants
- Man's activities e.g. cultivation, mining and road construction
- Mixing up of soil burrowing animals e.g. earth worms and termites

Any 3 x 1 ½ =(1 ½ mks)

3

- Little amount of water is used/economics water use
- Reduces incidences of certain leaf diseases/ Fugal discs
- Can be used in sloppy areas because there is no risk of surface run off/no risk of soil erosion
- Water under low pressure can be used
- Some fertilizers and pesticides can be applied with irrigation water.
- Minimizes growth of weeds

(Any 4 x ½ = (2mks)

4.

- Adds nutrients.
- Increases microbial activity in the soil
- Improves water holding capacity/reduces leaching/ improves capillarity

- Buffers soil PH
- Moderates soil PH
- Moderates soil temperatures

5.

- Type of crop-soil nutrient status
- Stage of growth of crop
- Expected yield

6.

- Lowers soil acidity raises soil ph(modifies ph
- Increases the calcium content of organic matter
- Improves soil structure through flocculation of soil particles/improves drainage.
- Facilitates the availability and absorption of Nitrogen and phosphorus
- Improves legume nodulation and N fixation
- Encourages multiplication of micro-organisms in the soil

7.

- Free from foreign materials e.g. weeds
- Gives rise to vigorously growing plants
- Have high germination percentage
- Free from pest and diseases attack/healthy
- True to type not contaminated (Any 4x ½ = 2mks)

8.

- Easy to determine plant population in a given area
- Ensure high quality produce.



- Ensures high production
- Facilities optimum use of nutrient moisture and light
- Permits use of machines when carrying on subsequent farm operations
- Facilities control of pests and e.g. ground

9.

- Pollution of the environment
- Loss of plant nutrients and soil microorganisms
- Siltation of dams and rivers
- Reduction of soil depth
- Destruction aid farm structures ( Any 4 x ½ = 2 mks)

10.

- Burning pasture during grazing season, cultural method
- Moving/physical method
- Use of biological agents/ Biological methods

11.

- Provide feed during period of scarcity/ distribute available forage for livestock through the year
- Ensure better and proper utilization of land
- Can be sold for money

12.

- Top dress with N fertilizers occasionally/ apply manure
- Control weed

- Practice controlled grazing to avoid denudation
- Cut back dry and unpalatable stems to encourage fresh re-growth/ topping
- Re- seeding when necessary
- Irrigation when necessary
- Control of pest (Any 4 x ½ = 2 mks)

13 (a)

GDP- is the sum total of goods and services produced by a country within a period of one year. (1 x ½ = ½ mk)

16.

- To keep check on income and expenditure / profit and loss
  - To know which activities are financially viable/ weakness and strength of the business
  - To obtain knowledge of the total value of the farm/ the value of assets and liabilities for farm planning
  - To assess credit worthiness
  - To provide information for tax purposes
  - Organizing agriculture field days for the local community
  - Participating in agricultural exchange programs both locally and internationally
- (Any 4 x ½ = 1 ½ mk)

17.

- Organizing and participating in annual YFC rallies and camps
- Participating and completing in ASK show activities e.g livestock judging
- Planting trees/ carrying out agricultural project in schools

- Organizing agricultural field days for the local community.
- Participating in agriculture exchange programs both locally and internationally.

(Any 4 x ½ = 2 mks)

18.

- Adds- organisms matters
- Recycles soil nutrients
- Helps to control soil erosion
- Improves drainage of swampy areas
- Plays an important part in the hydrological

**B- Trapping and killing**

Use of scare crows/ scaring

Poisoning/ rodenticide usage 1x1 = ( 1 mk)

21.

(a) The law state that “if successive units of one input are added to fixed units of other inputs, a point is eventually reached where additional output per additional unit of input will decline” ( mark as a whole)

- (i) At the end of the third unit of fertilizers application
- (ii) This is the least profitable unit of fertilizer application beyond which there would be a loss
- (iii) Marginal returns (MR) at the point of optimum production

$$MR = \text{Kshs } 1200 \times 2 = 2400/=$$

22. (a)

- Read the label/ the manufactures instruction

- Measure the requirement amount of fungicide
- Place it into a container and mix thoroughly
- Powder has dissolved completed/ has formed slurry
- Pour the mixture into the knapsack sprayer though the sieve
- Spray the mixture onto the crop

(b) Blight (late or early) powdery mixture ( 1 mk)

(c)

- Spray following the direction of the wind
- Wear protective clothing
- Avoiding eating or smoking while handling fungicides
- Avoid spillage of the fungicide/ avoid containing the environment
- Do not suck/ blow a blocked nozzle (Any 4 x Vi = (2 mks)

23.

(a) blackjack/ *Bidens pilosa*

(b)

- To avoid competition for nutrients, moisture arid light
- Black jack seeds may contaminate some crops/ farm practice
- Blackjack may be an alternate host to some pest e.g aphids which may attack crops like beans
- Black jack seed prick and irritate workers (Any 2 x 1 = 2 mks)

(c) - MCPA

- 2, 4-D

(d) At what stage of growth of maize should the weed be controlled using a pest?

- 10 to 15 cm hi

- 2 to 4 weeks after emergence

1 x 1 = 1 mk

### SECTION C

24.

- Clear the place, if bushy
- Dig/prepare the site to a desirable tilt/ Fine with
- Remove roots and stone from the site
- Prepare nursery beds 1- 1.54 wide by any convenient length
- Prepare raised or sunken nursery bed depending on moisture content available
- Level the Nursery bed ( Any 4 x 1 = mks)

(b)

- Make shallow furrow drills/ about 10cm apart
- Apply phosphates fertilizers in the furrows/ Drill and mix with the soil
- Sow seeds by drilling
- Cover the seed lightly with soil
- Apply some mulch after sowing seeds
- Water the nursery thoroughly ( Any 3 x 1 = 3 mks)

(c)

- Remove the mulch as soon as seedling emerge
- Water the nursery at least twice a day, preferably morning and late evenings
- Remove weeds as they come up

- Thin young seedlings if over crowded/ prick seedlings
- Control diseases
- Harden off the seedling/ remove shade gradually and reduce frequency of watering ( Any 5 x 1 = 5 mks)

(d)

- Water nursery thoroughly before transplanting
- Dig the planting holes at appropriate depth
- Select healthy seedlings
- Uproot seedlings carefully with as much as possible to avoid root damage/ use a garden trowel
- Transport seedling carefully to the end field using appropriate means
- Transport on a cloudy day or late in the afternoon
- Place insecticide in the hole to control soil borne pests
- Place the seedling in the planting holes at the same depth they were in the nursery bed
- Fill the hotels with soil and firm around the seedlings
- Apply mulch or erect a shade
- Water the seedling thoroughly (Any 5 x 1 = 5 mks)

25. (a)

- Availability of adequate funds or capital/ inputs
- Training of personnel or availability of advisory services on managerial skills
- Loyalty on the part of all farmers, co-operators and officials to support their organization

- Proper and accurate record keeping and accountability for all operations
  - Efficiency with which produce from farm are marketed
  - Honest on the part of personnel with regard to the handling of co-operative finances
  - Timely payment of farmers dues
- (b)
- Diversification/ growing a variety of crop or having various enterprises so that if one fails has something to rely on.
  - Insurance against losses/ taking insurance policy for farming activities so that in case of failure the enterprises are covered.
  - Inventory marketing/ strategic farming keeping farm product and selling at when prices are favorable
  - Flexible enterprises engaging in enterprises that can be stopped or started early as condition change.
  - Rationing of inputs using just sufficient inputs such that in case of losses the cost are not too high
  - Using more certain husbandry practices using practices that the farmer is sure of and has used in the pas.
  - Hedging/ contract marketing making arrangements with marketing agencies in advance so that changes in price after the arrangement do not change the price of the farmer's produce.
  - Selecting more certain enterprises selection of enterprises that the done well in the area/ tried though research
- ( Any 7 x 1 = 7mks)

C.

- Determination of the farmer's objectives and preference in order to eliminate those production possibilities that are unsuccessful
- Determination of available resources to the farmer in order to establish his/her abilities and limitations.
- Determination of possible productive enterprises
- Determination of tentative budget/ translation of physical plan into a financial
- Determination of yield of various enterprises
- Development of financial flow in order to establish the capital requirements
- Examination of the plan to ensure that it is consistent, workable and desirable
- Determination of government policies and regulation to make the plan realistic.

(Any 8 x 1 = 8 mks)

26. (a)

- Ponds/ water pumps
- Dams/ weirs
- Roof catchments
- Rock catchments
- Retention ditches/ level terraces

(b)

- Continuous cropping without giving the land a rest
- Burning
- Ploughing along the slopes/ farming on step land
- Deforestation



- Ploughing along river banks
- Cultivating when the soil is too dry or wet
- Overgrazing/ overstocking
- Flooding/ application of a large amount of water at high rate
- Over cultivating the land to fine tilth/ pulverizing the soil

(c)

- Mulching by reducing the speed of run- off and reducing the impact of raindrops
- Contour farming by reducing the speed run off
- Terracing effective length of the slope and consequently slowing down speed of running off
- Planting trees/ holding soil particles together hence reducing effects of wind erosion and reducing the impact of rain drops
- Establishing and maintaining vegetated water; by reducing the impact of livestock on the soil erosion
- Establishing trash lines/ sones lines by reducing speed of run- off an effects of wind erosion

## K.C.S.E AGRICULTURE PAPER 2 MARKING SCHEME

### SECTION A

1. Hampshiredown (1 mark)
2. Cross cut saw/ Tenon saw/ Back saw/ spokes have/ circular plane 2 x ½ = 1 mk)
3. Removal/ harvesting of marketable size fish from the pond (1 mk)
4. Prevents metal engine parts from rusting
  - Promotes free movement of engine parts by reducing friction
  - Traps foreign materials e.g. soot, dirt and dust
  - Lowers engine temperature by conducting away excess heat
  - Helps in sealing compression between the piston and cylinder (4 x ½ =2mks)
5.
  - Keeps radiator fins free of rubbish and dirt. Water pump lubricated regulated/ weekly
  - Ensure that the fan belt is tightly fitted/ proper tension/ lock bolts and nuts should be tightened
  - All pipes should be fitted tightly to avoid leakage
  - To top up the level of water in the radiator before using the tractor(4 x ½ =2mks)
6.
  - Disc ploughs work better in dry/ sticky and hard soils than mould board plough
  - There is less hindrance to operations chances of breakages because the discs roll/ ride over obstacles
  - The maintenance costs of disc plough are lower than the moldboard.

- Disc plough require less tractor- power to pull than moldboard

7.

- An outlet to drain off excess water
- An inlet for fresh water supply
- A spill way channel to take away excess water/ overflow water
- A screen to prevent escaping of fish/ entry of unwanted objects/ fish
- A fence to keep away predators/security
- Dikes walls embankment/ leaves ( 4 x ½ =2 mks)

8.

- Through the mough/ natural openings
- Through umbilical cord
- Through respiratory track
- Through injury/ wounds on the body
- Though bites by disease vectors ( 4 x ½ = 2 mks)

9.

- Spraying insecticides the breeding places
- Clearing the vegetation
- Use of appropriate insecticides to spray cattle
- Sterilization of the male tsetse flies (4 x ½ = 2mks)

10.

- Overgrown hooves
- Wet and muddy conditions
- Physical foot injuries (2 x ½ = 1 mk)

11.

- High milk yields
- Good health
- Fast growth/ early maturity
- High growth/ maturity
- Good mothering ability
- Good body conformation ( 4 x ½ = 2 mks)

12.

- They can browse and survive on poor vegetation
- They have hooves with hard pads which enable them to traverse large area sandy ground/ flat hooves
- They can tolerate high temperature/ have thick skins
- They can travel long distances for several days with very little water
- Store fats in humps/fats can be metabolized to metabolic
- Long eye lashes to prevent entry of sand/ have nose flaps

13.

- Softening moistening of the food
- Storage of food ( 2 x ½ = 1 mks)

14.

- Using of caustic potash stick
- Use of disbudding iron/ dehorning
- Use of dehorning saw or wire
- Use of rubber ring and elastrator

- Use of dehorning collusion ( 4 x ½ = 2 mks)

15.

- Overcrowding
- Pest infestation/ pest diseases
- Noise/ strangers
- Lack of food and water
- Sudden change in routine/ management
- Unbalanced diet
- Fluctuation in temperature
- Introducing new bird in the flock

16.

- Feeding the queen / the broods
- Protecting the hive from intruders
- Collecting nectar, pollen, gums and water/ Foraging
- Cleaning the hive
- Building combs and sealing cracks
- Making honey bee wax
- Scouting ( 4 x ½ mk= 2 mks)

17.

- Should be rain- proof/ leak proof
- Should be well ventilated
- Should be easy to clean
- Should be well lit

- Should have adequate space
- Drought free
- Good drainage (4 x ½ = 2 mks)

### SECTION B

18. (i) A- Furrow opener  
 B- Fertilizer hopper  
 C- seed hopper  
 D- Press wheel (4 x ½ = 2 mks)

Clean hopyjers/ tuirow openers after use

- Lubricate/ grease moving parts
  - Replace worn out lost bolts and nuts
- (ii)
- Check tension of chains/ drive sprockets before use
  - Tighten loose bolls and nuts (Any 2 x 1 = 2mks)

- (b) (i) E - adjustable spanner  
 F - Ring spanner (2 x ½ = 2mks)
- (iii) Tool E can be used for tightening or loosening more than two sizes of nuts and belts ( Rejects one is adjustable ( 1 mk)

- 19 (a)
- (i) Slatted floor 1 x1 = 1 mk
- (ii) (H 40 – 60 cm high
- (b) (i)

- To allow urine and dung to pass through
- To keep the floor dry ( Any 1x 1 = 1mk)

(ii)

- Prevailing direction of the wind
- Safety/ security
- Proximity to the dairy shed/ accessibility of the dairy shed
- Drainage
- Topography ( Any 3 x 1 = 3 mks)

20. (a) Term used to express that amount of the crude protein absorbed by an animal's body from a feed (1 x 1/2 = 1mk)

(b) Pearson's square method

Maize 10% DCP 35-

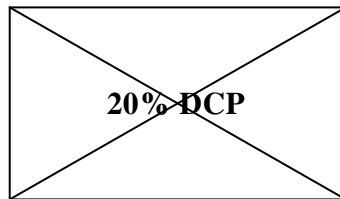

20 = 15 parts of maize

Sunflower 35% DCP

Sunflower

Amount of maize  $15/25 \times 200 = 120\text{kg}$

Amount of sunflower  $10/25 \times 200 = 80\text{ kg}$

Mark as shown in the diagram

(4 x 1 = 4 mks)

- 21 (a) G - Muzzle  
H - Poll  
I - Shoulder  
J - Heart girth (4 x ½ = 2 marks)

(b) Ear lobes/ deep in the ear

Anus

Vulva

Under tail (4 x ½ = 2mks)

22. (a)

- Spray the entire backline from my shoulder to the tail head
- Spray the sides in a zigzag motion to trap me retain the wash from the backline
- Spray the belly with me nozzle facing upward
- Spray the scrotum/ udder and the hind flanks carefully
- Spray both hind legs up to and including the heels
- Spray under the tail head and the area around the anus and vulva
- Hold the tail switch on to the rump and spray it thoroughly to ensure complete wetting
- Spray the neck and the foreleg; from the flanks to the heels
- Spray the head and face making sure that bases of the horns are thoroughly wetted,
- Spray the inside of the ears (10 x 1 = 10 mks)



- (b) (i) Causal organisms – Virus/ virus types O, A, C/ south African types  
SAT1, SAT2, SAT3, / Asian type 1 ( 1 x 1 = 1mk)

(ii)

- Cattle
- Pigs
- Goats
- Sheep
- Profuse salivation ( Any 2 x 1=2 mks)
- Blisters which are painful around the mouth and hooves of the feet  
leading to lameness
- Drop in milk production in lactating cows
- Sharp rise in temperature/ high fever
- Emaciation
- Complete loss of appetite
- Diarrhoea ( Any 4 x 4 = 4 mks)

(iv) Quarantine

- (a) Vaccination every 6 months
- (b) Slaughter and destruction of carcass
- (c) Regulations of livestock movement by issue of movement permits
- (d) Burn/ bury dead animals

23 (a)

- Select good animals on the basis of high yielding cows
  - Select animal with good health
  - Select animals having high fertility
  - Select animal having good dairy conformation
  - Cull poor producers
  - Use superior bulls/ semen from superior bulls to service the cows
  - Mate heifers when fully mature considering weight/ age
  - Breed cows 60- 90 days after calving to maintain after calving interval of one year
  - Keep animals health by routine vaccination
  - Control internal parasites by routine drenching using appropriate drugs
  - Treat sick animals
  - Avoid physical injuries to the animals/ predisposing disease factors
  - Improve sanitation/ cleanliness in the farm
  - Feed the cattle on a balanced diet
  - Give adequate feeds
  - Give clean and uncontaminated feed
  - Provide plenty of clean water
  - Provide minerals/ vitamins
  - Provide housing/ avoid overcrowding/ provide shelter that is leak proof
  - Use proper milking techniques
  - Milk at regular intervals
- ( Any15 x 1 = 15mks)

(b)

- Control stocking rate
- Control of water pollution
- Supply adequate feed regularly
- Provide appropriate feed
- Aerate the water by ensuring constant inflow and outflow of water
- Control predators
- Harvest fish at the correct maturity stage
- Maintain appropriate water level in the fish pond always
- Add manure or fertilizer in pond to encourage growth of planktons

(Any 5 x 1 = 5 mks)

24. (a)

- Farm operations can be achieved on time
- Large area can be covered within a short time
- Reduce drudgery/ makes work easy and enjoyable
- Better job is done mechanically than human labor/ increased efficiency
- High yields are obtained because farm operations are carried out on time
- Pest and disease outbreak can be controlled relatively in a shorter time
- Tends to encourage farmers to consolidate their land
- Farmers benefit from economies of scale
- Use less labor

( Any 6 x 1 = 6 mks)

### **(b) TWO STROKE CYCLE ENGINE**

- Cheap to buy and easy to maintain
- Produce less power/ do less heavy
- Mainly air cooled
- Inefficient in fuel and oil utilization
- Easy to transport to different areas of the farm land e.g hilly areas\
- Require two complete upward and downwards movements of to be position, and one revolution of crankshaft
- There is no provision of oil in the sump, during induction, to lubricate the crankshaft
- Simple in construction with no valves
- Has 2 openings exhaust

### **(c) FOUR STROKE CYCLE ENGINE**

- Expensive to buy and maintain
- Produce more power/ do heavy work
- Efficient in fuel and oil utilization
- Mainly water cooled
- Difficult to transport easily due to weight
- Require 4 complete upwards and downwards
- 2 revolutions of 1 he crankshaft
- Engine have oil in the sump to lubricate the crankshaft bearings
- Complex in constructions with two valves ( inlet and outlet)

- Has no parts and inductors ports (Any 6x 1 = 6 mks)
  
- Using a dip – stick to check the level of oil in the sump
- Check the fuel tank to ensure there is adequate fuel for the day’s job
- Check the level of the electrolyte in the battery and adjust accordingly.
- Grease/oil moving parts
- Check-fan belt. Tension’ and condition and adjust accordingly
- Check level of water in radiator and top up if necessary
- Check air cleaner to ensues that there is no dirt/check level of oil
- Check tyre pressure before work and adjust accordingly
- Tighten bolts, nuts and pins
- Open and remove the dirt from sediments bowels

(Any 8x1=8 marks)

## K.C.S.E AGRICULTURE PAPER 1

### SECTION A [30 MARKS]

*Answer ALL the questions in this section in the spaces provided.*

1. Give **four** conditions of the land which may make it necessary to carry out reclamation practices. [2marks]
2. List **three** physical weathering agents in the soil formation process [1<sup>1</sup>/<sub>2</sub>]
3. State **two** mechanical methods of separating soil particles according to size during soil analysis [1marks]
4. Give **two** benefits of possessing a land Title Deed to a farmer. [1mark]
5. Give four advantages of crop rotation [2 marks]
6. State four factors that should be considered when classifying crop pest
7. State **three** functions of boron in crop development. [1<sup>1</sup>/<sub>2</sub>]
8. Outline **four** observable indicators of economic development of a nation [2marks]
9. Give three factors that may influence the price of an agricultural commodity.[1<sup>1</sup>/<sub>2</sub>]
10. Name three examples of leguminous fodder crops. [1<sup>1</sup>/<sub>2</sub>]
11. Give two factors that may determine the size of a pit for silage making [1mark]
12. Give three reasons for controlling weeds in pastures. 1<sup>1</sup>/<sub>2</sub>
13. State six characteristics of a productive soil. ( 3 mks)
14. State any five qualities that should be considered when selecting seeds for planting ( 2 ½ mk)
- 15 (a) State four practices which encourage soil erosion ( 2 mks)  
(b) Name two forms of gully erosion ( 1 mk)

16. (a) State four advantages of land consolidation ( 2 mks)  
 (b) Give two advantages of leasehold tenure system in farming ( 1 mk)

SECTION B ( 20 MARKS)

Answer all the questions in this section in the spaces provided

17. The table below shows the demand and supply of potatoes at UKULIMA market.

Price (Kshs)	Quantity demanded (in bags)	Quantity supplied (in bags)
1200	50	250
1000	90	200
800	150	150
600	225	70
400	335	0

- (a) Using suitable scales, draw and label a graph showing the relationship between the demand and supply of the potatoes at UKULIMA market. (5mks)
- (b) What is the equilibrium price of the potatoes? ( 1 mk)
- (c) From the graph determine:
- (i) The number of bags of potatoes that would be bought if the price per bag is Kshs 900/= ( 1 mk)
- (ii) The price of a bag of potatoes if 180 bags are supplied ( 1 mk)

18. The diagrams labeled A<sub>1</sub>, A<sub>2</sub>, A<sub>3</sub>, and B below illustrate materials and methods of vegetative propagation. Study them and answer the questions that follow.

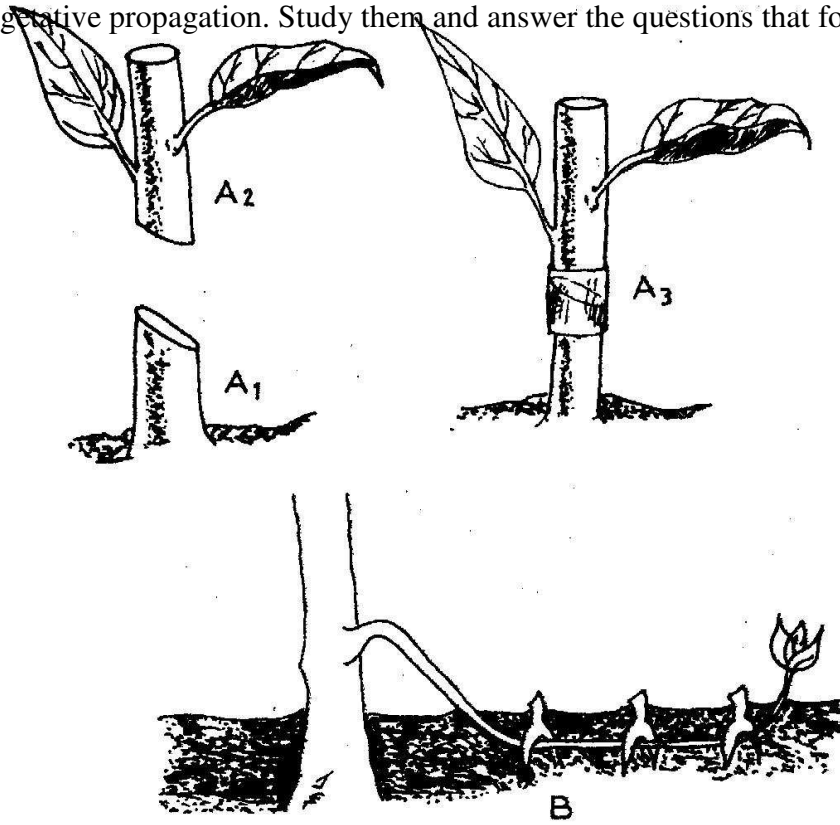



(a) Name the parts labeled A<sub>1</sub>, and A<sub>2</sub>

( 2 mks)

A<sub>1</sub>

A<sub>2</sub>

(b) Name the methods of propagation illustrated in diagrams A<sub>3</sub> and B

( 2 mks)

A<sub>3</sub>

B

19. Study the crop illustrated in the diagram below and answer the questions that follow

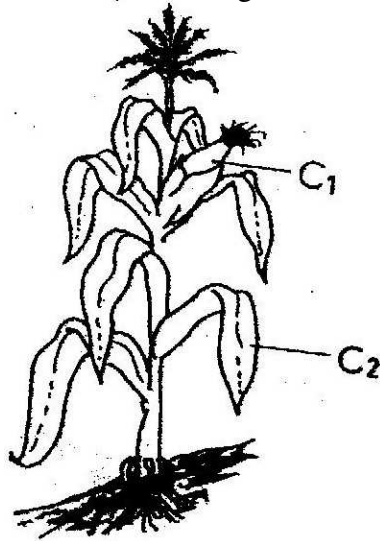

- (a) Name one insect pest which attacks the part labeled C<sub>1</sub> and one disease which attacks the part labeled C<sub>2</sub> (2 mks)
- C<sub>1</sub>
- C<sub>2</sub>
20. A member of young farmers club was advised to apply a complete fertilizer 30:20:10 in a tomato plot measuring 10m long by 5m wide at the rate of 300kg per hectare
- (a) State the percentage of P<sub>2</sub>O<sub>5</sub> in the complete fertilizer ( 1 mk)
- (b) Calculate the amount of fertilizer the member would require for the plot (2 mks) (Show your working)

21. The diagrams labeled D and E below are illustrations of coffee established using two different formative pruning systems. Study them and answer the questions that follow.

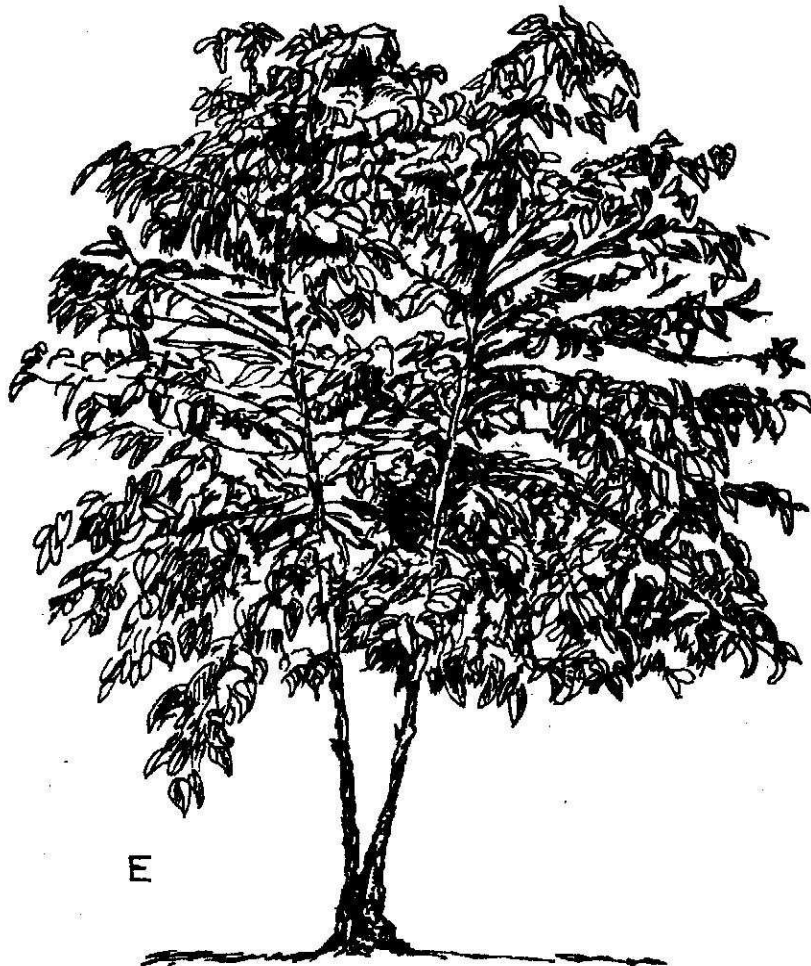

(a) Name the system of pruning illustrated in diagram D above ( 1mk)

(b) Outline how the pruning system illustrated in diagram E is carried out (2mks)

**SECTION C (40 MARKS)**

*Answer any two questions in this section in the spaces provided after questions 24*

22. (a) Describe the field production of irrigated rice under the following sub-headings

(i) Land preparation ( 7 mks)

(ii) Water control ( 6 mks)

(b) Describe the management of trees grown under various agro- forestry systems

( 7 mks)

23. (a) Describe the problems of marketing of agricultural produce ( 10 mks)

(b) Discuss the importance of budgeting in agricultural production ( 10 mks)

24. (a) Discuss the importance of irrigation in farming ( 12 mks)

(b) Explain the factors that influence the type of irrigation to be used in a farm

( 8 mks)

## K.C.S.E AGRICULTURE PAPER 2

### SECTION A (30 marks)

*Answer ALL the questions in this section in the spaces provided.*

1. Give two reasons for using litter in a poultry house. (1mk)
2. Name two diseases of poultry that are controlled by vaccination. (1mk)
3. State two factors that could lead to failure to conceive in sows after service. (1mk)
4. Give two causes of scouring in calves. (1mk)
5. State three factors that would determine the amount of concentrate fed to dairy cattle. (1 ½ marks)
6. Give three ways of stimulating milk let-down in a dairy cow. (1 ½ marks)
7. State two reasons for dehorning cattle. (1mk)
8. List two equipment used in handling cattle during an agricultural exhibition. (1mk)
9. State three signs of anthrax infection disease observed in the carcass of cattle. (1 ½ mks)
10. Give three effects of external parasites that are harmful to livestock. (1 ½ mks)
11. State four factors to consider when siting a fish pond. (2mks)
12. State three adjustments that should be carried out on a tractor – mounted mouldboard plough in preparation for ploughing. (1 ½ mks)
13. a) Name four breeds of dairy goats. (2mks)  
b) Mention two distinguishing characteristics of the Bactrian camel breed. (1mk)
14. State five methods of maintaining good health in livestock. (2 ½ mks)
15. List four sources of farm power which are environmental friendly. (2mks)

16. State three maintenance practices that should be carried out on a feed trough. (1 ½ mks)
17. Name four systems of a tractor engine. (2mks)
18. List three types of calf pens. (1 ½ mks)
19. State four conditions that would encourage hens to eat eggs in poultry production (2mks)

**SECTION B (20 MKS)**

*Answer ALL the questions in this section in the spaces provided.*

20. The diagrams labeled A and B below show the teeth arrangements in hand

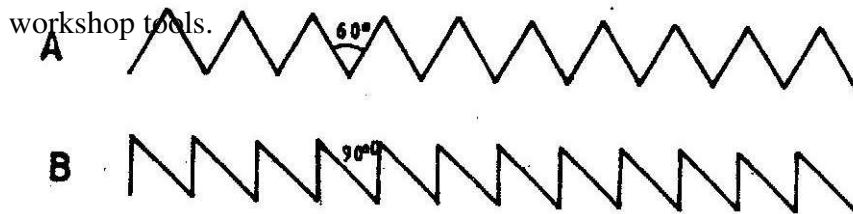

- a) Identify the tools represented with by the teeth arrangements A and B. (1mk)
- A .....
- B .....
- b) State one functional difference between tools represented by the teeth arrangements A and B.

A .....

B .....

- c) Give two maintenance practices for the tools represented by the teeth arrangement shown above. (2mks)
21. a) The diagram below illustrates a method of identification in livestock production. Study the diagram and answer the Questions that follow.

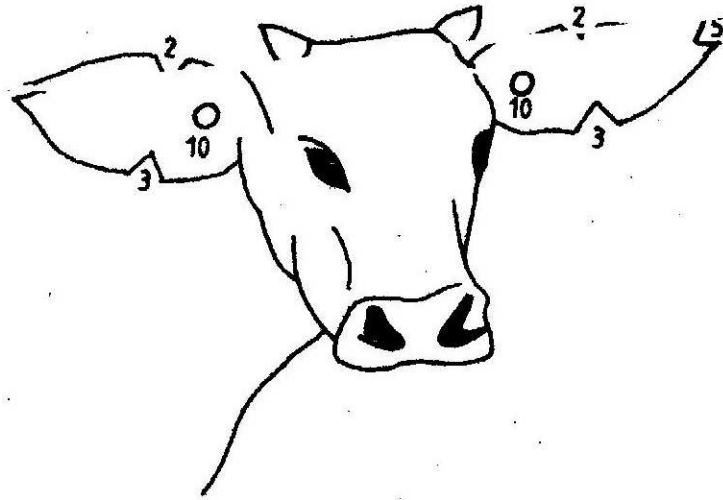

- i) Name the type of identification illustrated above. (1mks)
- ii) Give the identification number of the animal illustrated in the diagram above. (1mk)
- iii) Using diagrams illustrate how you can identify animals Nos

24 and 36 using the above method. (2mks)

Animal No. 24

Animal No. 36

(b) If a sow was successfully served on 27<sup>th</sup> September, 2006, state the date she is likely to have furred. (1mks)

22. The diagram below shows a type of a farm gate. Study the diagram and answer the questions that follow.

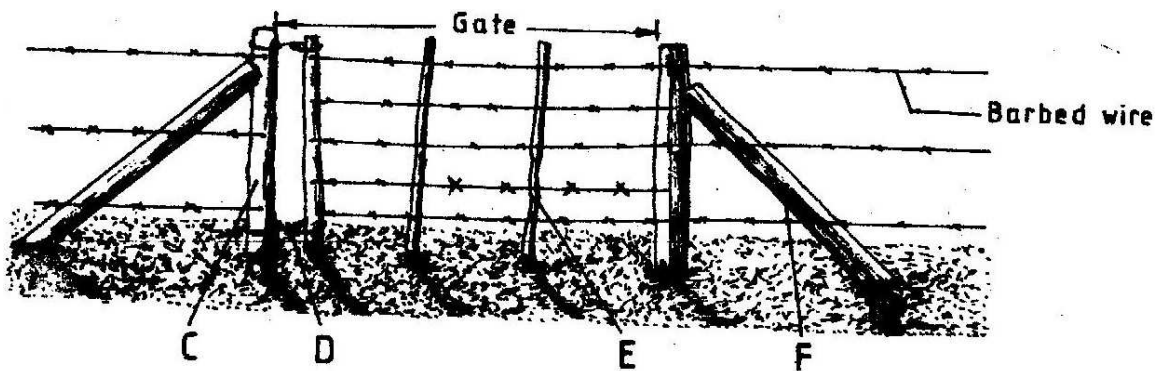

a) Identify the type of gate shown (1/2 mk)

b) Name the parts labeled C, D and E. (1 ½ mks)

C .....

D .....

E .....



- c) i) State one function of the part labeled F. (1mk)  
 F .....
- ii) State two functions of the gate illustrated above. (2mks)

23. The diagram below shows a farm implement. Study it and answer the questions that follow.

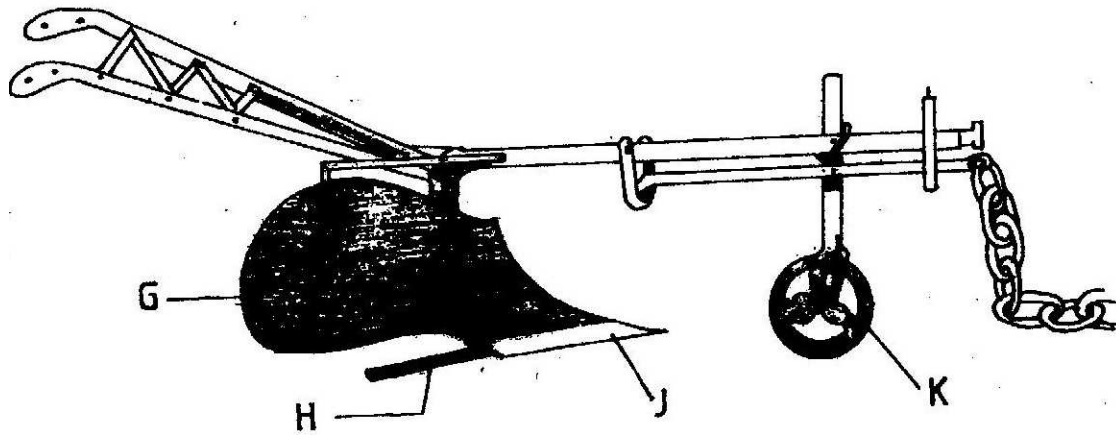

- a) Identify the farm implement illustrated above. (1mk)
- b) Name the parts labeled G, H, J and K.
- G .....
- H .....
- J .....

- K .....
- c) State four functions of the farm implement illustrated above. (2mks)

**SECTION C (40 marks)**

*Answer any TWO questions in this section in the spaces provided after question 26.*

24. a) Describe the advantages of the battery system of rearing layers. (10mks)  
b) Outline the factors to consider when selection livestock for breeding.
25. a) Name the strokes in a four stroke engine and describe how each operates. (12mks)  
b) Describe the functions of the gear box in a tractor. (8mks)
26. a) Name and describe the features of an ideal calf pen. (9mks)  
b) Discuss pneumonia in calves under the following sub – headings:  
i) Predisposing factors (3mks)  
ii) Symptoms (5mks)  
iii) Control measures (3mks)

## KCSE AGRICULTURE MARKING SCHEMES PAPER 1

1.

- Very steep land
- Water logging / marshy area.
- Forested / Bushy area.
- Rocky / Aridity/Tsetse fly infested areas.

2.

- Wind / Moving water
- Temperature changes
- Moving ice/ Glacier

3.

- Using a sieve / sieve analysis.
- Sedimentation method

4.

- Can be used as a security for credit.
- Encourage long term investments
- Reduces land disputes
- Motivates the farmer to conserve soil water.

5.

- Improves soil structure
- Controls soil borne pests and diseases.
- Ensure maximum utilization of farm labour.
- Aids in weed control

- Improves soil erosion.
- Security incase of failure of one crop.
- Add nitrogen through N – fixation by Rhizobium bacterial when legumes are included.

6.

- Crop attacked / mode of feeding .
- Whether field or storage pest.
- Crop parts attacked.
- Stage of crop growth attacked.
- Scientific classification e.g. insects, mite, rodents.

7.

- Important in calcium utilization.
- Necessary in sugar translocation
- Needed in water absorption.
- Aids in translocation of sugar nitrogen and phosphorous.
- Aids in fruit development.

8.

- Development of infrastructure.
- Housing status of the citizens.
- Increase in recreation facilities.
- Ratio of teachers to students.
- Improvement in the level of technology/ more industrialization.

9

- Price of substitutes.
- Price expectations in future.
- Quality of the commodity
- Tastes and preference of the commodity.

10

- Medicago sativa/Lucerne
- Leucaena leucocephala/calliondra.
- Artemisia annual/Artemisia.
- Calliandra calothyrsus/calliandra
- Desmodium species
- Kenya white clove/ Infolium sepiosum

11

- Quantity of forage available for ensiling.
- Number of animal to cater for.
- Length of the period of forage scarcity.
- Bulkiness of the material.

12

- To avoid poisoning of livestock.
- Minimize diseases spread.
- To ensure the forage is of high palatability.
- Minimize competition for nutrients, space light.
- To increase the life span of the pasture.

13

- Has appropriate depth
- The right PH/ Good soil structure.
- Good water logging capacity.
- Well aerated/good drainage.
- Free from soil borne pests and diseases.
- Rich in nutrients in the right proportions.

14

- Should be of high purity.
- Should be free from pest and disease attack.
- Should be appropriate size
- Should be mature.
- Should be free from any physical damage.
- Should be of high percentage of germination.
- Should be suitable to the ecology of the area.

15 (a)

- Over –cultivation, overstocking/overgrazing.
- Deforestation/planting annual crops on steep slopes.
- Burning of the vegetation.
- Ploughing up and down the slope.

(b) V- shaped gullies U-shaped gullies.



20. a)  $p_2 o_5 = 20\%$

b) 1 ha = 10,000m<sup>2</sup> requires 300kg of fertilizer.

5m x 10m<sub>2</sub>= 50m<sub>2</sub> requires x of the fertilizer

$$10,000 x = 300 \times 50$$

$$X = \frac{300 \times 50}{10,000} = \underline{1.5}$$

$$10,000 \quad 2$$

21. a) Single stem pruning.

b) The main stem is capped at 38cm above the ground to encourage more suckers to grow. Select two strong and healthy suckers and remove the others. The selected suckers should form a U-shaped to avoid splitting.

22. (a)

- Clear the land
- Divide the land into plots of 0.4 ha
- Construct /repair bunds /dykes.
- Construct/ repair inlet and outlet channels
- Flood the field to a height of 7.5 – 10cm above the soil surface.
- Carry out primary tillage
- Puddle the soil to a fine mud.
- Uprooted weeds should be heaped on the bunds.
- Level the plots by dragging a wooden board/ jembe.

(ii)



- Flood the plots to a depth of 7.5 – 10 cm.
- Leave the field flooded for 4 days.
- During transplanting, drain the field to a depth of 5cm,
- Introduce water gradually as the crop establishes.
- Maintain the water level at 1/3 the height of the crop
- Change water every 2-3 weeks or when it is cold.
- Water should allow to flow slowly through the field
- Drain the field 2-3 weeks before harvesting.

(b)

- Irrigation during the dry season.
- Timely pest control.
- Timely weed control
- Pruning, Coppicing/pollarding/capping.
- Thinning/selective harvesting.
- Protection against damage by animals.
- Grafting/budding.
- Fertilizer/manure application
- Construction of micro-catchments
- Structures around the trees
- Provision of shade/mulch to reduce evaporation.

23. (a)

- Competition from cheap/synthetic / products, causing loss.
- Change in supply of the produce; leading to price fluctuation

- Change in market demand; leading to price fluctuation.
- Lack of market information; leading to exploitation by middle .
- Inadequate capital; hence poor financing of various marketing functions.
- Poor quality of produce; leads to price fluctuation.
- Seasonally of produce; leads to price fluctuation.
- Bulkiness of most agricultural produce; making it expensive and difficult to transport.
- High perishability; this leads to low quality of produce
- Poor storage structure; leading to heavy losses of the produce.
- Lack of knowledge in marketing leading to heavy losses.
- Government interference through its agents leading to price fluctuation
- Acts as a record for future reference.
- Helps in deciding the viability of the enterprise
- Assist in securing credit.
- Helps to predict the profitability of the enterprise.
- Aids in detecting problems easily hence correction is done in good time.
- Aids in making management decisions especially when comparing between enterprises.
- Helps in making changes in the farm.
- Ensures periodic analysis of the farm business.
- Encourage the farmer to be efficient so as to meet the target.

24 (a)

- Enables one to grow crops during the dry seasons.

- It's a method of land reclamation/ allows crop production in arid and semi-arid areas.
- Makes it possible to grow crops in special structures e.g. green house.
- Enables one to grow crops that require high amount of water e.g. paddy rice.
- It supplements rainfall in case it inadequate in crop produce.

(b)

- Topography,
- Soil type
- Type of crop to be irrigated.
- Amount of water available.
- Technology available.
- Distance of the source of water to the field.
- Capital available, skills available
- Climate factors of the area.

## K.C.S.E PAPER 2 MARKING SCHEMES

1.

- To keep the house warm.
- To absorb moisture from poultry droppings.
- Keeps birds busy scratching, thus reducing cannibalism.

2.

- Marks's disease, avian spirochaetosis.
- Fowl typhoid, Gumboro/ infectious bursa disease.
- New castle, fowl pox, infectious bronchitis.
- Chronic respiratory disease.
- Infectious coryza of chicken.

3.

- If the sow is barren.
- Poor nutrition if the calf cold milk.
- Poor timing services

4.

- Overfeeding/ giving the calf cold milk.
- Lack of colostrums.
- Irregular feeding of calf.
- Feeding milk at wrong temperature.
- Feeding milk in dirty containers/ feeding contaminated milk.

5.

- Level of milk production

- Quality of roughages.
- Availability of the concentrates.
- Economic factors/cost of concentrates.
- Physiological status.

6.

- Washing the udder with warm water.
- Allow the calf to suck for a while
- Feeding the cow during milking.
- Regular milking time
- Sound associated with milking.
- Massaging the udder when washing it.

7.

- To make the animal docile
- Reduce, incidence of animals injuring each other/attendant.
- Reduce incidence of animals damaging farm structures.
- Increase feeding, watering transportation space.
- Add aesthetic value to the animal.

8.

- Halters, Nose bull ring and leading stick. Rope.

9

- Carcass lacks rigor mortis.
- Excess bloating
- Water tar-like blood oozes from body openings

- Oozing blood clot.
- Rapid purification.

10

- Introduce toxins that are harmful to the animal.
- Cause anaemia/transmit diseases.
- Cause wounds that allows secondary infection.
- Cause irritation which leads to scratching/destroy wool.

11.

- Source of water/Type of soil
- Topography.
- Closeness to homestead/accessibility.
- Closeness to the market/consumers.
- Far away natural sources of fish.

12.

- Adjust the depth of ploughing
- Adjust furrow width of ploughing
- Front furrow depth.
- Lowering /raising ploughing pitch.

13.

(a)

-Saanen, anglo-Nubian, Toggenburg. British alpines, Jamnapari.

14

- proper feeding. prophylaxis, quarantine.

- Proper housing, control of parasite.
- Practice farm hygiene.
- Routine vaccination.
- Use of healthy breeding stock.
- Timely treatment of the sick livestock.
- Control of vectors, dipping, spraying.

15

- Wind power. Water power, animal power solar energy. Human power, Biogas  
Geothermal.

16.

- Painting metallic parts
- Regular washing.
- Repair broken parts/cracks.
- Replace lost parts.

17.

- Fuel systems, 1
- Lubrication system.
- Electrical system.
- Ignition system,
- Cooling system,
- Hydraulic system
- Power transmission system

18

- Permanent calf pen.
- Movable calf pen.
- Concrete floor calf pen.
- Slatted floor calf pen

19.

- Calcium deficiency in the birds body.
- Blight light in the laying nests
- Birds laying on the floor.
- Presence of broken, soft shelled eggs.
- Prolonged stay of eggs in the laying boxes.
- Idleness of birds.
- Inadequate feeding.

20

(a) A- cross-cut saw B- rip saw

(b) A- cutting across the grain B- cutting along the grains

(c)

- Wipe blade with an oily rug.
- Regular sharpening of the teeth.
- Ensure the handle is firm,
- Teeth setting.
- Straighten the blade if bent.
- Proper storage of the foods.



21(a) (i) ear notching (ii) Number 40 (forty)

(ii) AC.  $10+5+5+2+2$  ( $17+17$ )

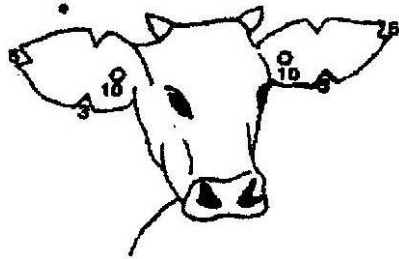

**Animal No 36**

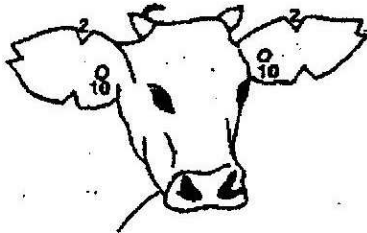

**Animal no 34**

(b) Between 18-1-2007 and 20-1-2007

22. (a) Barbet wire gate
- (b) C – gate post/King post/strainer  
D – Wire loop  
E – Dropper.
- (c) (i)
- Support the gate post
  - To ensure the barbet remains taut.
- (ii)
- Prevent movement of farm animals outside
  - Keep away livestock from outside.
  - Used as entrance into/exit from the farm.
23. (a) Animal/ ox-drawn plough.
- (b) G – Mould board.  
J – Share  
H – Land slide  
K – Land wheel
- (c)
- Plough/ridging
  - Harvesting root crops e.g. groundnuts.
  - Weeding row planted crop.
  - Opening furrows for planting.

24. (a) **Advantages of battery system.**

- Higher egg produce due to less energy wastage.
- Easy to keep individual production records.
- Control cannibalism and egg eating.
- No contamination of water and feed.
- Birds are not exposed to predators, parasites and diseases.
- Facilitates culling and handling.
- Easy to collect eggs
- Egg losses are reduced.
- Many birds are kept in a given/high stocking rate.
- Eliminates broodiness.
- Birds still have tender meat at culling due to confinement.
- Facilitates mechanization.
- Keeps eggs clean.

(b) **Factors considered in selecting livestock k for breeding.**

- Body confirmation.
- Fertility/breeding ability.
- Adaptability of the breed to the arts/hardiness.
- Mothering ability in case of females.
- Production potential/yielding capacity.
- Temperament/behaving e.g. cannibalism egg eating.

- Deformities/abnormalities e.g. one eye lameness.
- Offspring performance
- Age of animal.
- Growth rate, quality produce
- Disease resistance, prolificacy.
- Lifespan/reproductive life.

25. (a) **Operation of a four stroke engine.**

(i) **Induction stroke/sunction.**

- The piston moves down the cylinder, causing the inlet valve to open and draw in fresh supply of petrol vapour and air into the cylinder, exhaust valve closed

(ii) **Compression stroke.**

- The inlet valve closes and the piston moves up the cylinder. This compresses the fresh fuel mixture into the combustion chamber, exhaust valve to close.

(iii) **The power stroke.**

- Fully compresses the fresh fuel mixture and as a result a spark is produced at the spark plug. This causes the fuel mixture to ignite and expand resulting in pressure that forces the piston down the cylinder. Inlet valve closed exhaust valve closed.

(b) **Functions of gearbox.**

- Helps the driver to select any forward or reverse gear.
- Adjust speed of the driver from the engine crankshaft to the driver shaft.
- Helps to alter the speed ratio.
- Enables the power from the engines to be more easily applied to the work done by the tractor.
- Enables the driver to stop the tractor movement without stopping the engine or without foot oppressing on the clutch all the time.

26. (a) **Features of an ideal calf pen.**

- **Concrete/raised stated floor** – Easy to maintain cleanliness.
- **Dry litter/bedding** – Maintain warmth.
- **Proper lighting** – Should have good supply of natural light/sunlight.
- **Proper drainage** – facilitate free flow of urine and water to avoid dampness.
- **Draught free** – The structure should stop strong winds from blowing into the calf pen.
- **Proper ventilation** – Structure should allow for fresh air circulation.
- **Security** – Should be strong enough to keep away intruders/wild animals.

(b) **Pneumonia in calves.**

(i) **Predisposing factors**

- Overcrowding of calves in the pen.
- Dampness/chilliness in the pen.

- Poor ventilation.
  - Age/younger calves are more prone to pneumonia than older calves.
  - Effects of diarrhea and other illness.
- (ii) Symptoms.
- Rough hair coats/ruffled hair.
  - Loss of appetite.
  - Abnormal lungs sounds e.g. whizzing.
  - Emaciation, frequent coughing.
  - Nasal discharge.
  - Fluctuating body temperature.
  - Dull and reluctant to move.
- (iii) Control measures.
- Treating the sick calve with antibiotics.
  - Providing warmth in pens.
  - Maintaining good sanitation in pens.

Isolating sick calves to avoid spread of the disease.