

**PAST PAPERS
COMPUTER STUDIES
PAPER 1
(THEORY)
OCT/NOV 1998**

SECTION A (40 MKS)

Answer all the questions in this section in spaces provided.

1. Using a program flowchart explain the “WHILE...DO” interaction construction. (3mks)
2. Explain two uses of an uninterruptible power supply unit (2mks)
3. Explain the meaning of BACKUP (2mks)
4. Define an operating system (2mks)
5. State two advantages of electronic spreadsheets over manual worksheets. (2mks)
6. State two roles of a system analyst (2mks)
7. Define a primary key field (3mks)
8. State three functions of a database management system (3mks)
9. a) Define local area network
b) State any two components of a local area network (2mks)
10. a) State two types of computer output devices (2mks)
b) State a situation where real time processing would be appropriate. (1mk)
11. State three functions of the central processing Unit (CPU) (3mks)
12. a) Explain the difference between system software and application programs. (2mks)
b) Explain the difference between digital and analogue computers. (2mks)
13. a) Explain the difference Random Access Memory and Read Only Memory (2mks)
b) State in which memory the monitor program would be stored. (1mk)
14. State the two requirements of computer program testing (2mks)
15. For each of the following file organization methods, state an appropriate storage medium.
a) Serial
b) Random (2 mks)

SECTION B (60 MARKS)

Answer question 16 and any other three questions

16. Students sat for a test in computer studies. The table below gives the marks obtained and the number of students obtaining the marks.
Write a program in a structured high-level language to calculate the mean of the result. The formula for the mean is given in the table below.

(15mks)

Marks obtained (x)	Number of students (f)
10	1
15	2
20	6
25	5
30	10
35	6
40	4
45	2
50	1
55	1

Formula for the mean:

$$\text{Mean} = \frac{\sum fx}{\sum f}$$

17. a) Briefly explain the following terms:
i. cell
ii. range
iii. label
iv. value
v. Function
- b) A spreadsheet has the following entries

	A	B	C	D	E	F	G
1	PROJECTED BUDGET						
2	Percent	10.0%					
3							
4	ITEM	1996	1997	1998			
5	Food	56,000					
6	Clothes	24,000					
7	Fees	50,000					
8	Transport	20,000					
9.	Entertainment	15,000					
10							
11							

Provide a formula for cell C5 that can be copied onto cell D5 and the range C6...D10 to give a uniform increase of 10% of the previous year's value for each item. (3mks)

- c) State **two** advantages of word processors over manual typewriters (2mks)
 - d) List **three** formatting features of word processor (3mks)
 - e) Explain the difference between the printing of multiple copies and the printing of multiple pages. (2mks)
18. a) state any **three** reasons why people may resist the introduction of computers at their place of work. (3mks)
- b) Explain the difference between data privacy and data security. (4mks)
- c) State **two** operational methods of an organization ensuring the security of data. (2mks)
- d) Explain the use of computers in health care (6mks)
19. a) i) Define normalization (2mks)
- ii) State three objectives of normalization (3mks)
- b) What is a distributed system? (3mks)
- c) State any **four** criteria for choosing an operating system (4mks)
20. a) Match the computer generation with the technology used to make the Processor
- | | | |
|-------------------|-------------------------|--------|
| <u>Generation</u> | <u>Technology</u> | |
| Third | Thermionic valves | |
| First | Integrated circuits | |
| Fourth | Transistor | |
| Second | Large scale integration | (4mks) |
- b) Draw a block diagram showing the function units of computer hardware. Name the units. (6mks)
- c) i) List **three** types of secondary storage media (3mks)
- ii) State **one** advantage and one disadvantage of a laser printer (2mks)

PAPER 1
OCT. /NOV. 1999
2 ½ HOURS

Instruction to Candidate

This paper consist of Two sections; A and B

Answer all the questions in section A

Answer question 16 and any other Three questions from section B

All answer should be written in the spaces provided on the question paper.

SECTION A (40 MARKS)

Answer all questions in this section

1. State any three functions of a computer (3mks)
2. Give two types of storage devices used in a computer giving an example of each. (4 mks)
3. Give any three precautionary measures considered to ensure the safety of computers in a computer laboratory (3mks)
4. Define
 - a) File
 - b) Record
 - c) Field
5. List two features of word processor (2mks)
6. Differentiate between the hardware and software components of a computer giving an example of each (4mks)
7. What is program documentation? Give two examples of program documentations (3mks)
8. Give two differences between high-level and low-level languages. (2mks)
9. Worksheet cells are referenced using the column letter and row number e.g. D2 is cell in column D and row 2.
Use the sample worksheet provided to answer the questions below.

	A	B	C	D	E	F
1	Moth	Jan.	Feb	Mar.	April	Total
2	Fees	460	460	460	460	
3.	Food	300	350-	305	270	
4.	Electricity	100	100	100	100	
5.	Fuel	150	150	150	150	
6	Transport	38	270	150	300	
7	total					

- a) Write down the data type that is stored in cells C5 (1mk)
- b) What cell contains the data items representing transport for the month of February? (1 mk)
- c) Write down the formula that may be used to compute the total in cell F6. (1mk)
10. Name any two types of graphs that are supported by spreadsheets (2mks)
11. What is a relationship database? (2mks)
12. As regards to communication within a computer network, what do you understand by the following terms: (2mks)
- i) Point –to-point
 - ii) Broadcast
13. Give any two types of data entries that may be input into a worksheet cell (2mks)
14. Give any two function of a system analyst. (2mks)
15. List any three program control structures used in programming (3mks)

SECTION B (60 MKS)

ANSWER QUESTION 16 AND ANY OTHER THREE QUESTIONS

16. The roots of the equation $ax^2 + bx + c = 0$ are given by the formula

$$X = \frac{-b \pm \sqrt{b^2 + 4ac}}{2a} \quad \text{And } a \neq 0$$

- a) Draw a flow-chart to compute the roots of the equation. (10mks)
- b) Using the flow-chart write a program that will compute the roots and if $b^2 - 4ac$ is negative, the program should display the message “NEGATIVE” (5mks)
17. A multinational organization has offered to donate computers to your school. The Board of Governors has requested you advise on the operating system to be used by providing answers the following questions.
- a) What is an operating system? (1mk)
- b) State and briefly explain any two types of operating systems (6mks)
- c) Briefly explain any four functions of an operating system. (8mks)
18. a) i) State one area where computer are used. (2mk)
- ii) Give any two advantages of using computers in this area (4mks)
- b) Explain the effect of computers technology in the following areas:
- i) Job opportunities
- ii) Job Skills
- iii) Communication (9mks)
19. A computer vendor has recommended the use of a computer database to your school for student information
- a) Explain to the Board of Governors what a database is and its functions (5mks)
- b) Give two examples of database systems (2mks)
- c) Briefly explain any two advantages and two disadvantages of using a Database (8mks)
20. a) what is a computer network topology? (2mks)
- b) Using appropriate diagrams, show any three computer network topologies (9mks)
- c) Briefly explain two reasons why organizations need to network their computers. (4mks)

**COMPUTER STUDIES
(THEORY)
PAPER 1
OCT./NOV. 2000**

**SECTION A (40 MARKS)
ANSWER ALL THE QUESTION IN THIS SECTION**

1. Write the following abbreviations in full. (3mks)
 - i) BCD
 - ii) ASCII
 - iii) EBDIC
2. Define the term array as used in computer programming (2mks)
3. Suggest how computers may in future be made more users friendly for persons that are
 - a) BCD
 - b) Without hands
4. State three advantages of computer networking (3mks)
5. Name six steps in program development cycle in their logical sequence. (3mks)
6. State two methods of minimizing dust in a computer laboratory. (2mks)
7. Differentiate between primary memory and secondary memory (2mks)
8. List the steps that you would use to correct wrongly spelt words in a document using the spell-checking feature. (3mks)
9. Differentiate between single-user and multi-user operating systems giving an example of each. (3mks)
10. State what is meant by each of the following and give an example of where each is used
 - a) Magnetic Ink character Recognition (MICR) (2 mks)
 - b) Optical Mark Read (OMR) (2mks)

11. In the following flowchart, what will be the value of the sum when printed?
Show how you arrive at your answer.

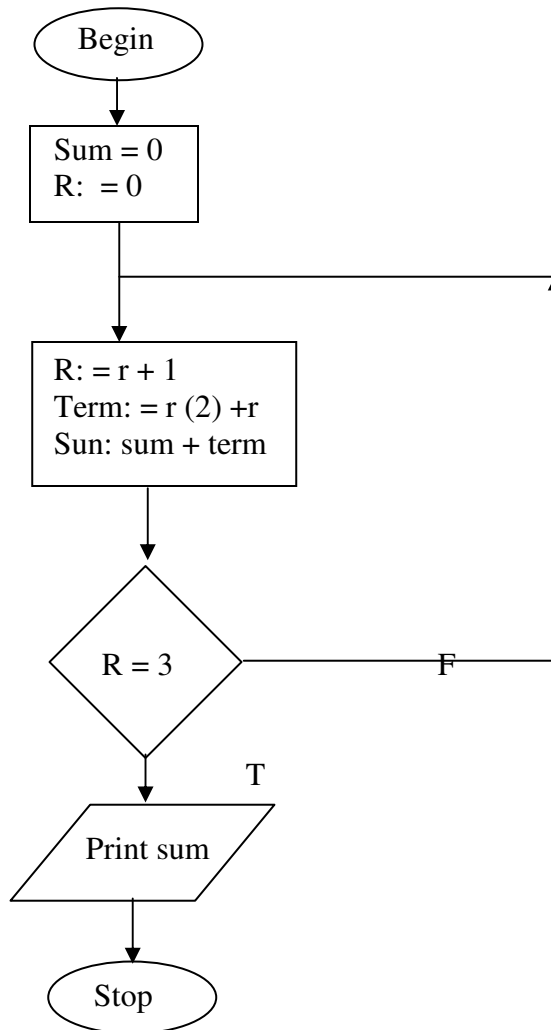

12. Distinguish between system software and application software. (2mks)
13. Explain any three of the terms: creating, editing, printing and saving as used in word-processing (3mks)
14. List three file organization methods in a computer (3mks)
15. What is the use of the search and replace feature in a word-processor? (2mks)

SECTION B (60 MARKS)**ANSWER QUESTION 16 AND ANY THREE OTHER QUESTIONS.**

16. A program is required for reading in a student's name and scores obtained in two subjects. The output of the program will consist of the student's name, the two scores, the average of the two scores and a comment. The comment is based on the average as follows:

Average	Comment
≥ 70	Good
< 70	Poor

- Write a program to solve the problem using a high level language. (15 mks)
17. a) what is meant by data communication in a computer network? (2mks)
- b) State what is meant by each of the following transmission media and give one advantage and one disadvantage for each .
- i) Twisted pair cables (3mks)
 - ii) Coaxial cables (3mks)
 - iii) Optic fibre cables (3mks)
- c) List four network elements in a location area network. (4mks)
18. Andrew, Jane, David and zablon had tea, sausages and bananas for breakfast. They took one sausage, two sausages, three sausages and one sausage respectively. In addition, they took a cup of tea and two bananas. Tea, sausages and bananas cost Ksh. 10, 15, and 5 respectively.
- By naming columns A, B, C, ... and rows 1, 2, 3 ...
- a) Construct a worksheet showing the above information. (7mks)
- b) State the expression you would use to obtain:
- i) Total expenditure by David (4mks)
 - ii) Total number of sausages taken (2mks)
 - iii) The cost of the cheapest item (2mks)
19. a) What are computer viruses? (2mks)

- b) i) State two ways through which computer viruses may be controlled (2mks)
ii) Explain how each of the two ways stated in b (i) above assist in controlling computer viruses. (2mks)
- c) Define each of the following computer terminologies (3mks)
i) byte
ii) bit
iii) word
- d) Convert the hexadecimal number FC1 to its binary equivalent. (6mks)
20. a) A firm intends to purchase new software. List three items that should accompany the software. (3mks)
- b) State and explain three ways that computer technology could make office work more efficient. (6mks)
- c) Explain the meaning of each of the following computer crimes; (6mks)
i) Hacking
ii) Fraud
iii) Piracy

**COMPUTER STUDIES
(THEORY)
PAPER 1
OCT. /NOV. 2001**

INSTRUCTION TO CANDIDATES

This paper consists of two sections; a and b

Answer all the questions in section a

Answer question 15 and any other three questions from section B

All answer should be written in the spaces provided on the question paper.

SECTION A (40 MARKS)

ANSWER ALL THE QUESTIONS IN THIS SECTION

1. Compare the two types of diskettes used in microcomputers in terms of physical size and densities. (2mks)
2. Why is it necessary to have a UPS in a computer laboratory? (2mks)
3. a) Explain what is meant by batch processing (1mk)
b) Give one advantage and one disadvantage of batch processing (2mks)
4. List any four high level programming languages (2mks)
5. A 3 by 4 matrix M is to be added to another 3 by 4 matrix array N so as to give a third 3 by 4 matrix array P. Using a high level programming language, write a program segment that assigns the sum of M and N to P. (4mks)
6. the first column in the table below contains the formulae as stored into the cell F10 of a spreadsheet. Enter the formulae, as they would appear when copied to the cell M20 of the same spreadsheet.

Formula in F10	Formula in m20
=D10* E10	
=A\$ 25	
=\$ D\$13	

(3mks)

7. Give three advantages of separating data from the applications that use the data in database design. (3mks)
8. Explain the impact of information on organizations in each of the following areas: (2mks)
 - a) Competition
 - b) Pace of growth

9. a) List any four tasks that an electronic spreadsheet should be able to perform other than calculations (2mks)
- b) Explain what is meant by automatic recalculation as used in a spreadsheet. (1 mk)
10. Describe the functions of the following computer hardware components:
- a) Mouse (2 ½ mks)
- b) Scanner. (1 ½ mks)
11. State two differences between Disk Operating System (DOS) and WINDOWS operating system.
- b. i) Define the term application software (1mk)
- ii) Give one example of application software (1mk)
12. a) Give one difference between internal and external commands in Disk Operating System. (2mks)
- b) Name two DOS commands that may be used for checking disk errors. (2mks)
13. Explain how a paragraph can be moved from one place to another in word-processing. (2mks)
14. Define the term structured programming. (2mks)

SECTION B (60MKS)

Answer question 15 and any other three questions from this section.

15. a) What is meant by each of the following terms:
- i) pseudocode (1 ½ mks)
 - ii) Flowchart (1 ½ mks)
- b) a program is required to list the first 1000 numbers in the series: 2, 4, 6, 8, 10,.. Draw a flowchart and write a program that can carry out this task. (12 mks)
16. the following car details are to be entered in a database; make, date-of-manufacture, colour and cost.
- a) Prepare a suitable database structure showing field names and their field types (5mks)
 - b) Explain how you index the data such that cars of the same make and colours are together (2mks)
 - c) Write a statement that can be used to select cars of the colour green (2 mks)
 - d) Give an instruction that would;
 - i) select cars whose cost lie between 500,000/= and 1,000,000/= (3 mks)
 - ii) Determine the average cost of all cars (3mks)
17. a) The diagram below represents the essential features of a computer system. Study the diagram and answer the questions that follow:

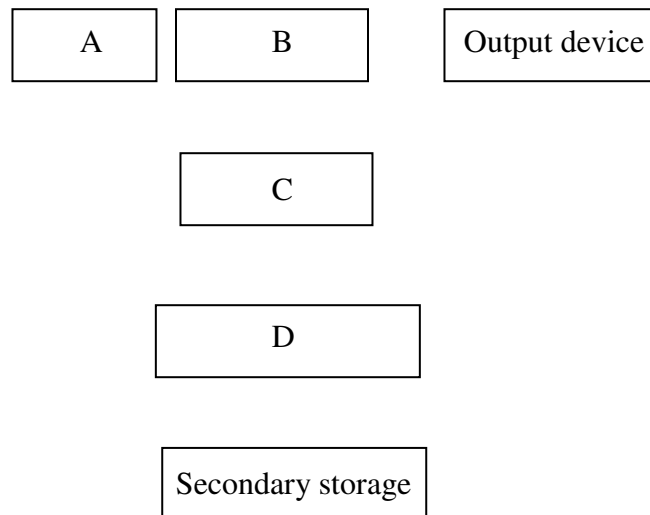

- i) Name the components (4mks)
- A
B
C
D
- ii) On the diagram above, indicate the direction of data flow using arrows. (3mks)
- b) Name the three types of buses in a computer system (3mks)
- c) Explain how CPU registers may be used to carry out a basic calculation such as:
 $2 + 7 = 9$
- d) Name two computers output devices. (1 Mark)
18. a) State three ways in which computer technology may affect employment patterns in organizations (3mks)
- b) State three ways in which computer technology may affect employment patterns in organizations (3mks)
- c) Suggest three strategies that can be employed to manage resistance to change (3mks)
- d) Give three advantages of computerization in an organization. (3mks)
19. a) In a computer based information system, state the purpose of the following files and give one example where such a file may be required in a school. (8mks)
- i) Report file
ii) Back-up file
iii) Reference file
iv) Sort file
- b) State three precautions that should be taken to ensure that diskettes are well stored. (3 mks)
- c) Distinguish between “serial” and Indexed sequential” file organization methods. (2mks)
- d) Distinguish between binary and octal number systems and give an example of each (2mks)

**COMPUTER STUDIES
PAPER 1
THEORY
NOVEMBER/DECEMBER 2002**

SECTION A (40 MARKS)

1. Describe the purpose of each of the following computer functional units: (2mks)
 - a) Control
 - b) Storage

2. Explain how each of the following would affect the suitability of a room for use as a computer room: (2mks)
 - a) Burglar proofed door
 - b) Availability of taps and sinks in the room

3. State three data representation codes used in computers (3mks)

4. State two types of documentation in program development and give the purpose of each. (4mks)

5. Suppose a 5 element array A contains the values 9, 12, 17, 7 and 20. Find the value in a after executing the loop below:

Repeat for k = 1 to 4
Set A [k +1]: = A [k]
[End of loop] (3mks)

6. State any three activities that occur in a program compilation process (3mks)

7. The formula = k20 + P\$ 18 was typed in cell L21 and then copied to cell M24 of a spreadsheet. Write the formula as it appears in cell M24. (2mks)

8. State two ways in which a computer may be used in efficient running of a hospital (2mks)

9. List three disadvantage of using traditional file management method (3mks)

10. Give one disadvantage of a single processor multi-user system (1mk)

11. List three differences between a micro-computer and super-computer. (3mks)

12. State and explain two reasons why word processing is one of the most common applications of many computer users. (2mks)
13. write- 1 in twos compliment notation in byte form (4mks)
14. Explain the following input/output terms as used in computer systems. Give an example for each (4mks)
 - a) Read
 - b) Write
15. State two disadvantages of networking.

SECTION B (60 MKS)

Answer question 16 and any other three questions from this section.

16. The following flowchart can be used to list the odd numbers between 0 and 100

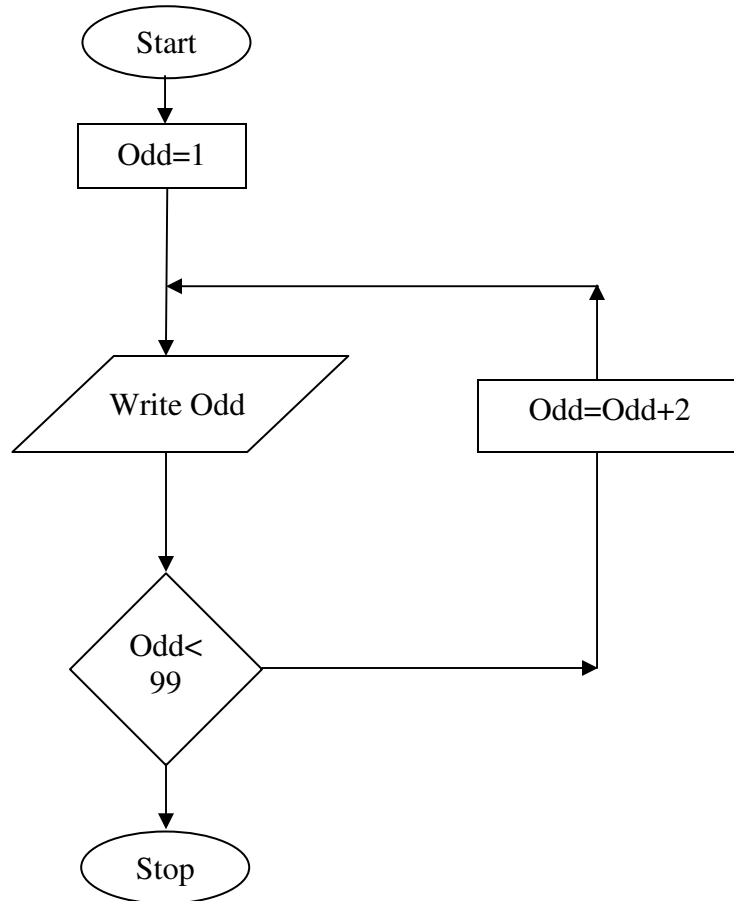

- a) Write a program segment for the flowchart using a high level language. (7mks)
- b) What would be the output from the flowchart if the statement in the decision box is changed to: (3 mks)
- i) Odd = 100
 - ii) Odd < 100
 - iii) Odd > 100
- c) Modify the flowchart so that it prints only the sum of the odd number between 0 and 100 (5mks)

17. a) List five precautions that can be taken to protect data stored in diskettes (5mks)
- b) State and explain two precautions that can be taken to help recover data lost through accidental erasure. (4mks)
- c) Describe each of the following data processing methods: (6mks)
- i) Batch processing
 - ii) Distributed processing
 - iii) Multiprogramming
18. a) i) What is a computer keyboard? (1 mk)
- ii) List four types of keys found on a computer keyboard. Give an example of each (4mks)
- b) Give four differences between present day's computers and the older generation of computers (4mks)
- c) i) State three advantages and one disadvantage of using a laser printer. (4mks)
- ii) Distinguish between a line printer and a page printer (2mks)
- 19 a) Identity three public Universities and three National Polytechnics in Kenya where further computer training is offered. In case, state the highest level of qualification that can be acquired in computer training. (6 mks)
- b) Distinguish between "Job replacement" and "Job displacement" in references to computerization. (2mks)
- c) Give four reasons why a firm may decide to computerize its operations. (4mks)
- d) An individual has a right to demand guarantee to privacy of personal information stored on a computer.
- Give three such types of information. (3mks)
20. a) Give three comparisons of the traditional file management method of typing a document on a typewriter against using a word processor. (6mks)

- b) i) Define the term spreadsheet (1 mk)
- ii) Give two examples of spreadsheet packages available in the market today (2mks)
- c) Explain the following terms as used in a spreadsheet:
- i) What if ...analysis (2 mks)
- ii) Cell (1 mk)
- iii) Formula (1mk)
- iv) Pie chart (2 mks)

**COMPUTER STUDIES
PAPER
(THEORY)
OCT./NOV. 2003**

INSTRUCTIONS TO CANDIDATES

This paper consists of two sections' A and B.

Answer All the questions in section A

Answer question 16 and an other three questions from section B

All answers should be written in the spaces provided on the question paper

SECTION A (40 MARKS)

Answer all the questions in this section

1. Computer systems are built from three types of physical components: processors, memories and I/O devices.
 - a) State two tasks of a processor (2 mks)
 - b) State function of I/O devices (1 mk)

2. Threats to the safety of computer systems take many forms such as: white-collar crime, natural disasters, vandalism and careless ness.
Give on way as to how each of these forms of threats can be controlled.

(2 mks)

3.
 - a) Explain the term nibbles as used in data representation in computers
 - b) Perform the following binary arithmetic giving the answers in decimal notation. (3 mks)
 - i) $1110.01111 + 11010001 .011$
 - ii) $1001011.011 - 111.111$

4.
 - a) Distinguish between machine and assembly language (2mks)
 - b) State the type of translator necessary for a program written in: (2mks)
 - i) High level language
 - ii) Assembly language

5. Briefly explain the purpose of the following types of program documentation: (3mks)
 - a) User manual
 - b) Reference guide
 - c) Quick reference guide

6. State any two features of a user-friendly program. (2mks)

- 7 a) Distinguish between labels and formulae with respect to spreadsheets (2mks)
- b) Consider the entries in the cells below.

Cell	B2	B3	C10	C11	C13
Entry	200	100	B2	B3	C10

State the value displayed in cell C13 (2 mks)

8. List three differences between wide area Networks (WAN) and Local Area Networks (LAN) (3mks)

9. Study the flowchart segment below and state the last value printed from the flowchart. (2 mks)

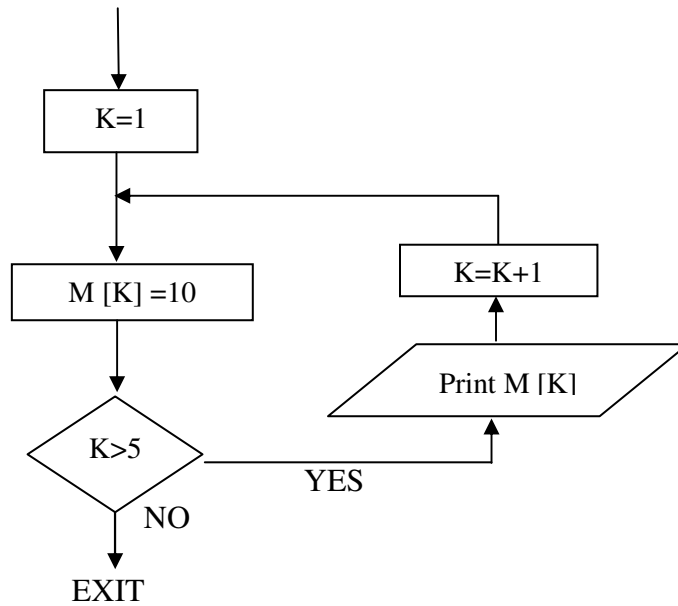

10. a) What is an expert system (1mk)
b) State any two components of an expert system (2mks)
11. Give two reasons why optical disks are better storage media compared to floppy diskettes (2mks)
12. What are the Dos commands used for the following? (2mks)
a) Changing directories
b) Viewing directories
c) Renaming directories
d) Deleting a directory
13. Distinguish between copying and moving text (2mks)
14. a) Name two methods of paper orientation (1mk)
b) Name two keys used to delete text in a document (1 mk)
15. Name two features a Database package (2mks)

SECTION B (60 MKS)

Answer question and any other three questions from this section

16. Study the flowchart below and answer the questions that follow.

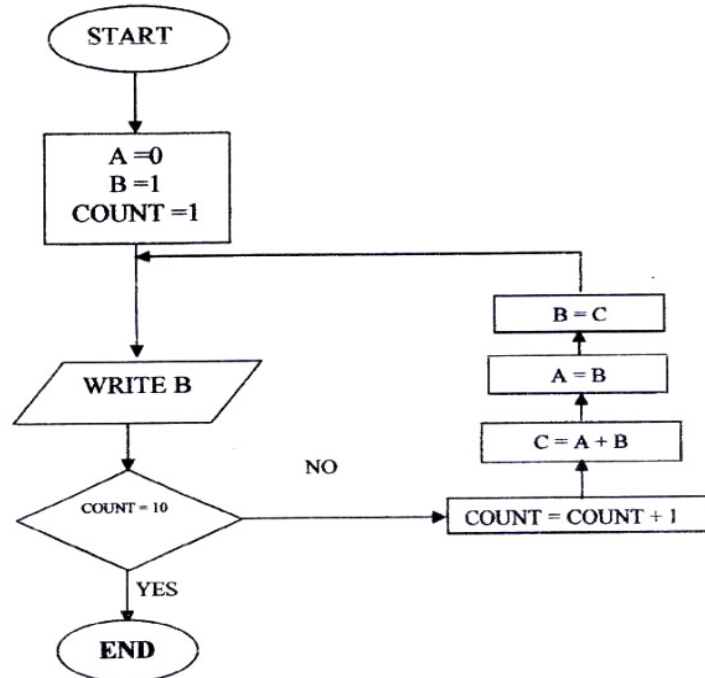

- a) Write a high-level language program for the above flowchart (7mks)
- b) List the outputs of the flowchart above (5 mks)
- c) Modify the flowchart so that it adds up all its outputs and displays the sum obtained (3mks)

17. A computer specification has the following details:

Pentium II
1.44 MB floppy disk drive
20 GB hard disk
Full multimedia
17" SVGA monitor
Pre-installed operating system
Pre-installed office suite

- a) What is meant by
 - i) 1.44 MB floppy disk drive?
 - ii) 20 GB hard disk?
 - iii) 17" SVGA monitor

- b) Which operating system might be pre-installed in this computer and why? (2mks)
- c) List three multimedia components (3 mks)
- d) i) what is meant by computer aided manufacture? (2 mks)
- ii) Give two examples of computer aided design software. (2mks)
18. a) Give three examples of network software (3mks)
- b) List any three items that may be referred to as data terminal equipment in a network (3 mks)
- c) Briefly explain the following terms as used in networking (4mks)
- i) Remote communication
- ii) Distributed processing
- d) State three advantages and two disadvantages of mesh network topology. (5mks)
19. a) a company has decided to computerize their operations. They have decided to purchase package instead of developing their own programs. Give three advantages and two disadvantages of this approach. (5mks)
- b) i) explain why a value such as 611233444555 may be displayed as ##### When typed in a cell of a spreadsheet (2mks)
- ii) How can the problem in b (i) above be corrected? (2mks)
- c) With reasons, briefly describe the most appropriate type of printer output device for the output of: (6mks)
- i) Customer invoices on multi-part stationery
- ii) Letters to customers
- iii) Detailed engineering designs
20. a) Distinguish between the following pair of terms (6mks)
- i) Data verification and data validation
- ii) Data encryption and passwords
- iii) Dry run and walk through
- b) Draw a labeled diagram to illustrate the internal structure of a diskette. (4mks)
- c) Give two differences between post office mail and electronic mail (E-mail) (2mks)
- d) Speed and accuracy are some of the advantages of using computers in banking. State three other advantages of use of computers in banking. (3mks)

COMPUTER STUDIES

PAPER 1

(THEORY)

OCT./NOV. 2005

2 ½ HOURS

SECTION A (40 MKS)

Answer all the questions in this section.

1. a) What is disk formatting? (1mk)
- b) Indicate whether the following devices are used for input or output (2mks)
 - i) Plotter
 - ii) Light pen
 - iii) Mouse
 - iv) Visual display unit
2. a) Explain why the following give one reason why they are not allowed in a computer laboratory. (2mks)
- b) For each of the following give one reason why they are not allowed in a computer laboratory. (2mks)
 - i) Smoking
 - ii) Eating foods
3. Distinguish between Real, integer and Character data types as used in programming (3 mks)
4. The cells k3 to K10 of a worksheet contain remarks on student's performance such as very good, good, fair and fail depending on the average mark. Write a formula that can be used to count all students who have the remark "very good" (3mks)
5. a) State the purpose of registers in a computer system (1mk)
- b) Name two multiprogramming operating systems (2 mks)
6. a) A series file comprises of records placed in positions 1 to 10. State the position of the end of file marker. (1mk)
- b) State the purpose of each of the following: (2mks)
 - i) File server software
 - ii) Communication software
7. a) Name the control structure depicted by the flowchart below. (1 mk)

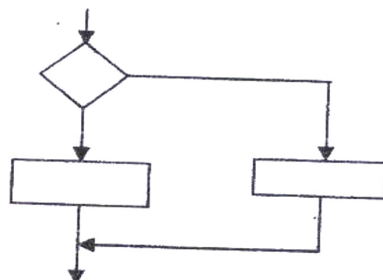

- b) Explain the following terms as used in program implementation. (2mks)
- i) Parallel running
 - ii) Direct change over
8. Consider the linear arrays:
- i) AAA (5:50)
 - ii) BBB (-5:10)
 - iii) CC (18)
- Find the number of elements in each array (3mks)
9. Define the term artificial intelligence (2 mks)
10. Name two types of relationships that can be applied in database design (2mks)
- 11 Explain binary Coded Decimal code of data representation (1 mk)
- a) Indenting
 - b) Alignment
 - c) Word wrap
12. Outline two ways in which computer can be used in hotels (2 Marks)
13. a) Explain Binary Coded Decimal code of data representation (marks)
- b) Write the number 41_{10} in BCD notation (1 mk)
14. Arrange the following data units in ascending order of size.
BYTE, FILE, BIT, NIBBIE (2mks)
15. State two health issues that may result from prolonged use of computers (2 mks)

SECTION B (60 MARKS)

16. a) State the stage of program development in which (4 mk)
- A flowchart would be drawn
 - The programmer would check whether the program does as required
 - The user guide would be written
 - The requirements specifications would be written.
- b) State the output of following flow chart segment (1mk)

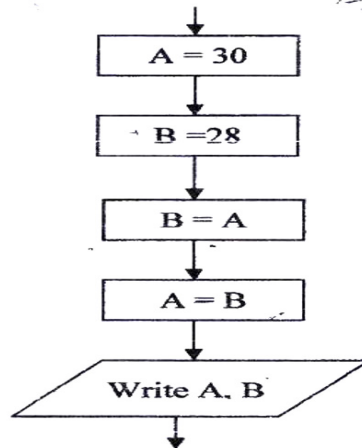

- c) i) Draw flowchart to compute the combined resistance R of two resistors R_1 and R_2 in parallel using the formula;
- $$R = \frac{1}{\frac{1}{R_1} + \frac{1}{R_2}} \quad (5\text{mks})$$
- ii) Write a program using Pascal or C languages for the flowchart in C (i) Above. (5 ½ mks)
17. a) List three paragraph formatting activities in word processing (3mks)
- b) Differentiate between bolding and highlighting text (2mks)
- c) The following information shows the income and expenditure for “bebayote “ matatu for five days. The income from Monday to Friday was Kshs. 4,000, 9,000, 10, 000, 15,000 and 12,000 respectively while the expenditure for the same period was Kshs. 2,000, 3,000, 7,000, 5,000 and 6,000 respectively
- Draw a spreadsheet that would contain the information. Indicate the rows as 1, 2, 3 And the columns as a, B, C (4mks)
 - State the expression that would be used to obtain:
 - Monday’s profit (2mks)
 - Total income (2mks)
 - Highest expenditure (2mks)

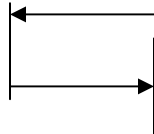
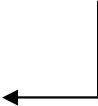
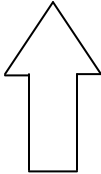
18. a) Subtract 011_2 from 1001_2 (1mk)
- b) Using two's compliment, subtract 7 from 4 and give the answer in decimal notation (4mks)
- c) Convert
- i) $91B_{16}$ to octal (3mks)
- ii) 376_8 to hexadecimal (3mks)
- iii) 9.625_{10} to binary (4 mks)
19. a) Explain what the following DOS commands will do when executed.
- i) A: \copy *.* B: (2 mks)
- ii) C: \> ERASE*. DOC (2mks)
- iii) b: \> Md EXAMS (2mks)
- b) i) With the aid of a diagram, explain hierarchical (tree) network topology (3mks)
- ii) List two advantages and two disadvantage of hierarchical network topology. (4 mks)
- Advantages:-
- Disadvantages:
20. a) Name and explain the function of the keyboard keys represented by the following symbols.
- i)  (2mks)
- ii) 
- iii)  (2mks)
- b) Simulation is one of the application areas of computers
- i) What is meant by the term simulation (1mk)
- ii) Name two application areas of simulation (2 mks)
- iii) State three advantages of computer based simulation (3 mks)
- c) Explain three ways in which computers have impacted on education (3mks)

COMPUTER STUDIES

PAPER 1

(THEORY)

OCT./Nov. 2006

2 ½ hours

SECTION A (40 MARKS)

1. What is meant by
 - a) Analogue data
 - b) Digital data (4 mks)

2. Distinguish between transcription and transposition types of errors and give an example of each (4mks)

3. a) what are peripheral devices? (1mk)

b) Give two examples of peripheral devices (1mk)

4. a) What meant by the term user-friendly as used in software development? (1mk)

b) Distinguish between the terms single-tasking and multi-user as used in operating systems (2mks)

5. What actions should be taken in case of a fire outbreak in the computer laboratory? (4mks)

6. a) What is an Internet Service Provider? (1mk)

b) An employee in a business company is charged with the responsibility of putting the company advertisements on the Internet.
 - i) State the professional title of the employee. (1mk)

 - ii) Give an example of software used by this employee to carry out the above task. (1mk)

7. Differentiate between COM ports and LPT ports (2mks)

8. Explain two ways in which ICT can enhance commerce. (2mks)

9. Explain the following software terms:
 - a) Portability (1 mk)
 - b) Modularity (1 mk)

10. a) State two application areas of a desktop publishing software. (2mks)

b) Explain the following graphic terms:
 - i) Rotate (1 mk)
 - ii) Crop (1mk)

12. a) List two arithmetic operations that can be performed on a row of numeric data in a word processing table. (1 mk)

- b) In each case of (a) above, write the expression used. (2mks)
13. List two methods of gathering information during system development process. (2mks)
14. Name three types of optical disks. (3mks)
15. The diagram below shows a formatted plate surface of a storage disk.

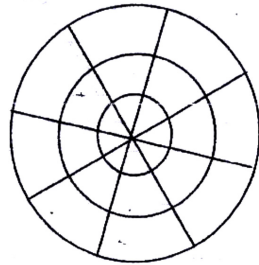

Shade and label:

- a) one sector (1mk)
- b) One block (1mk)

SECTION B (60 MKS)

Answer question 16 and any other three questions from this section in the space provided

- 16 a) List two examples of:
- i) Third generation languages (2mks)
 - ii) Object oriented languages (2 mks)
- b) Draw a flowchart to compare three non-equal numeric values A, B, C and prints the largest of the three. (11 mks)
- 17 a) One of the functions of an operating system is job scheduling. Explain what is mean by job scheduling. (1mk)
- b) List and explain three types of user interfaces. (6 mks)
- c) Describe the following categories of software:
- i) Firmware (1mk)
 - ii) Proprietary software (1mk)
- d) a new company XYZ intends to go into the business of desktop publishing. Advise the company on three computer hardware system specification features to consider as a measure of enhancing performance. (6 mks)
18. a) distinguish between the following sets of terms as used in spreadsheets. (2mks)
- i) Worksheet and workbook
 - ii) Filtering and sorting
- b) State one way in which a user may reverse the last action taken in a spreadsheet package. (1 mk)
- c) The following is a sample of a payroll. The worksheet row and column headings are marked 1, 2, 3, . and A, B, C. respectively

	A	B	C	D	E	F	G	H
1	NAME	HOURS WORKE D	PAY PER HOUR	BASIC PAY	ALLOWANCES	GROSS PAY	TAX DEDUCTIONS	NET PAY
2	KORIR	12	1500					
3	ATIENO	28	650					
4	MUTISO	26	450					
5	ASHA	30	900					
6	MAINA	18	350					
7	WANJIKU	22.5	250					
8	WANYAMA	24.5	250					
9	OLESANE	17	180					
10	MOSET	33	700					
	TOTALS							

Use the following expressions to answer the questions that follow:

- Basic pay = hours worked x pay per hour
- Allowances are allocated at 10% of basic pay
- Gross pay = basic pay + allowances
- Tax deductions are calculated at 20% of gross pay
- Net pay = Gross pay – tax deductions.

Write formulae using cell references for the following cells;

- i) D2 (1mk)
- ii) E4 (1mk)
- iii) F10 (1mk)
- iv) G7 (1mk)
- v) H5 (1mk)

- d) i) State three ways of moving round the page in a Desktop Publishing window. (3mks)
- ii) State two ways on how information & Communication Technology (ICT) can be used to reduce the spread of HIV/AIDS (2mks)
- 19. a) Describe the following terms with reference to security of data: (1 mk)
 - i) Log files
 - ii) Firewalls (1 mk)
- b) A student' database comprises of students' details table and fees received table as shown below:

Students' details table

Surname
Middle Name
First Name
Admission Number
Course

Fees Received table

Date
Amount
Receipt No.

- i) State the primary key field for each table. (2mks)
- ii) State the field, which should serve as the linking field for the two tables.

For more PAST KCSE PAPERS visit: www.kcse-online.info

- (2mks)
- c) Describe the following terms with respect to computer security:
- i) Logic bombs (2mks)
 - ii) Physical security (2mks)
 - iii) Tapping (2mks)
- d) List three functions of antivirus software. (3mks)
20. a) The diagram below shows four common network topologies A, B, C and D.

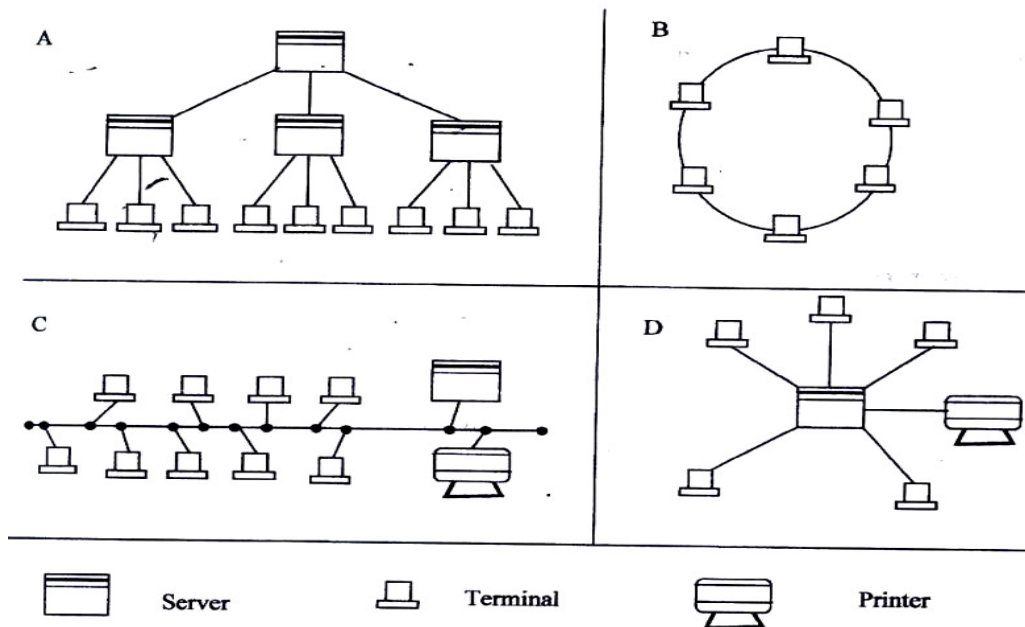

- i) Name the network topologies labeled a, B, C and D. (4mks)
- A
B
C
D
- ii) Explain what happens if server X in topology A fails. (1 mk)
- iii) List two problems associated with network topology B. (2 mks)
- iv) List two disadvantages associated with network topology D. (2 mks)
- b) Differentiate between Internet and World Wide Web: (2mks)
- c) Describe the following network services and identify their applications.
- i) Voice mail (2mks)
 - ii) Video conferencing (2 mks)

COMPUTER STUDIES
PAPER 1
(THEORY)
OCT/NOV/2007
2 ½ HOURS.

SECTION A (40 MKS)

Answer all the questions in this section in the spaces provided.

1. Describe the computer booting process. (2 mks)
2. State the functions of the following keys on the computer keyboard (2 mks)
 - a) Backspace
 - b) Insert (ins)
3. Jane has noticed the following problems in her computer keyboard (2mks)
 - It is taking longer time to start up;
 - It is often hanging;
 - Applications are taking longer to load.

State three possible causes of these problems and how they can be solved (3mks)
4. a) Define authenticity as used in software selection (1mk)
b) List four ways of acquiring software in an organization (2mks)
5. some of the storage disk available are: zip disks, 3 ½ inch floppy disks, DVDs and 5 ¼ inch floppy disks. Arrange these devices in ascending order of storage capacity. (2mks)
6. You have been asked to change your computer password. State a precaution you need to take in order to avoid each of the following:
 - a) Forgetting the password (1mk)
 - b) Hacking (1mk)
7. State four benefits of using a computer in a school library (2 mks)
8. Using six bits, find the two's complement of -23_{10} . (4 mks)
9. Explain data series, axis and legends as used in spreadsheet charts. (3mks)
 - Data
 - Axis
 - Legend

10. a) Describe the term data integrity. (2 mks)
b) State four situations in which data may lose integrity. (2mks)
11. State the function of each of the following:
a) Network interface card (1 mk)
b) Network protocol (1 mk)
c) Hub (1mk)
12. List four types of publications that can be designed by using desktop publishing software. (2mks)
13. Differentiate between the following pair of terms as used in database design:
a) Input mask and design. (2 mks)
b) Table and query (2mks)
14. List four factors to be considered when purchasing an operating system. (2mks)
15. Write an algorithm to compute the area of a triangle. (2mks)

SECTION B (60 MARKS)

Answer question 16 and any other three questions from this section in the spaces provided

16. Study the flowchart below and answer the questions that follow

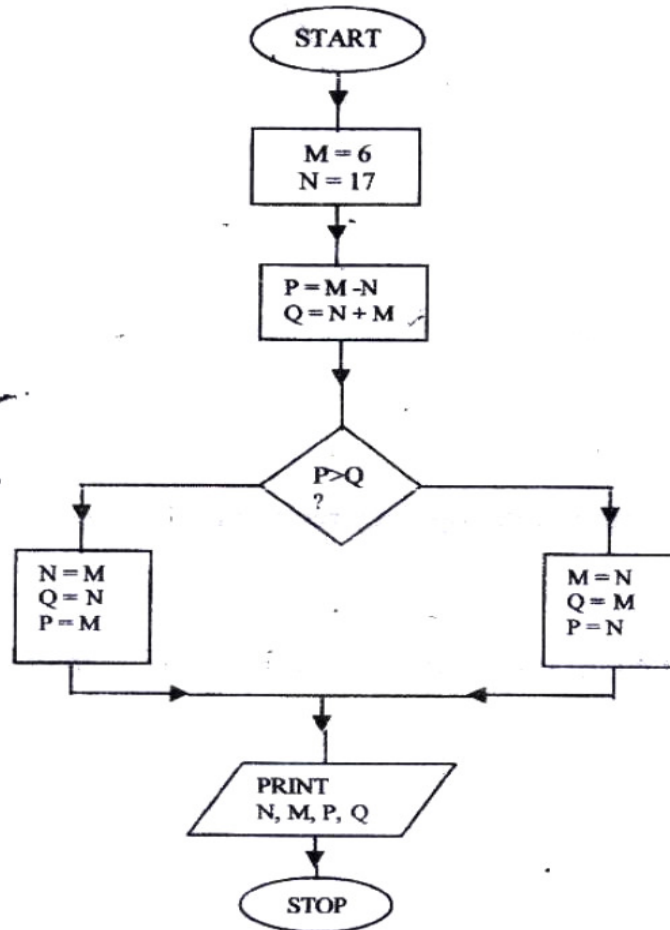

- i) Name the control structures used in the flowchart (2mks)
- ii) Determine the values of M, N, P and Q. (4 mks)

M..... N.....

P..... Q.....
- iii) Write the pseudo code for the flowchart (7mks)
- b) List **four** functions of an assembler (2 mks)

17. Define the following web related terms:

- i) Web browser (1mk)
- ii) Hyperlink (1mk)
- iii) Hypertext document (1mk)
- b) List six activities performed on the web (3mks)
- c) An institution has ten stand alone computers
 - i) Suggest with reasons the most appropriate topology required to inter-connect the computers. (3mks)
 - ii) State the necessary steps required to connect the computers to the internet. (4mks)
- d) Below is an email address:

ggitau @moest. edu.ke
↓ ↓ ↓
A B C

Name the parts labeled:

- i)
 - ii)
 - iii)
18. A computer C directory has folders for form 1, form 2, Form 3 and form 4. Each class has student's folders labeled according to their number. The students create their own folder for the subject the are studying based on the table shown below

Form 1	Form 2	Form 3	Form 4
OS	SP	Pr.	ADB
WP	DTP DB	Internet	

- a) Assuming there is one student per class, draw the corresponding directory tree structure. (6 mks)
- b) i) a form four student wants to create a folder to store her project. State the path for that project folder. (2 mks)
- ii) Suggest how the student can ensure that:

1. Work is not lost in case the hard disk fails. (1mk)
 2. The project is not copied by other students. (1mk)
- c) i). Other than I/O devices, list other three devices under the control of the operating system. (3mks)
- ii) Explain any one of the devices named in C (i) above (1mk)
- d) Define the term trouble shooting (1mk)
19. A manager wishes to replace the current manual system with a computerized one
- a) Describe three main areas that must be evaluated to justify the replacement (6mks)
- b) List the three areas that would be considered in the requirements specifications. (3mks)
- c) State and explain three ways that can be followed to replace the current system (6mks)
20. a) a head teacher keeps the following student details in a database: Name, address, Town, Date of Birth, Marks scored, Fees paid.
- i) Name the most appropriate primary key. Give a reason (2mks)
- ii) For each item in the student's details above, indicate its most appropriate data type as used in the database. (3mks)
- iii) Explain why input screens are better data entry designs than entering data directly to a table. (2mks)
- b) List two career opportunities associated with databases. (2mks)
- c) Distinguish between:
- i) A table in word-processing application and a table in a database application (2mks)
- ii) Mouse pointer and insertion point. (2mks)
- d) Outline the steps to be followed in order to merge cells in a word processing table. (2mks)

**SECTION II
MARKING SCHEMES**

**COMPUTER STUDIES
PAPER 1
(THEORY)
OCT. /NOV 1998
2 ½ HOURS**

SECTION A (40 MARKS)

1. Using a program flowchart explain the “WHILE ...Do” interaction construction. (3mks)

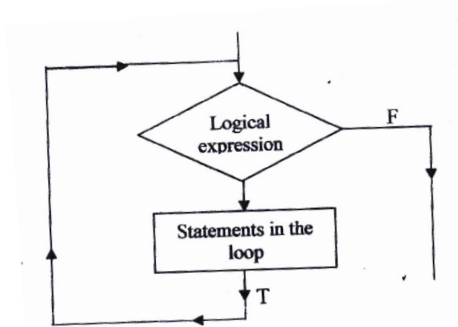

The statements in the loop are repetitively executed while the logical expression is true. Control will leave the loop only when the while statement is executed and the logical expression is false at that time.

2. Explain two uses of an uninterruptible power supply unit. (2mks)
- Regulate the flow of power
 - Store power shortly after power failure
3. Explain the meaning of BACKUP. (2mks)
- This is storage of a copy of program or data in another place to be used if the original is lost or damaged.
4. Define an operating system (2mks)
- This is part of the computing system that controls all the hardware and all the software.
5. State two advantages of electronic spreadsheets over manual worksheets. (2mks)
- It enables automatic recalculation
 - Editing is easy
 - Analysis of data is easy due to the use of formulas
 - Work is neat

- 6. State two roles of a system analyst. (2mks)**
- Plans and designs a new system
 - Coordinates schedules with a number of people e.g. programmers, managers, users etc.
 - Defines the objectives of the system
 - Carry out a feasibility study and write a report of a proposed new system
 - Studies the existing system
 - Analyses the system to establish its strengths and weaknesses
 - Prepare a report describing the existing system
- 7. Define a primary key field (3mks)**
- This is a field that is used to distinguish one record from another.
 - A candidate key that is selected to identify all the attributes uniquely.
- 8. State three functions of a database management system. (3 mks)**
- -It makes it easy to access information
 - -It stores large amount of data with many types of records occurring many times
 - -Helps in establishing relations between data items
 - -Offers many different user requirements
 - -Enables flexible editing features
 - -Offers data storage and retrieval
 - -Offers authentication services
 - -Offers transaction support
 - -Offers authentication services
 - -Offers integrity services
 - -Offers support for data communication
 - -Offers utility services e.g. import/export/ statistical analysis e.t.c.
- 9. a) define local area network. (2mks)**
- b) State any two components of a local area network (2mks)**
- file server
 - Printer server
 - communication controller (software)
 - workstation or terminals
 - Network interface cards (NIC)
 - Network cables
 - networking accessories e.g. accessories e.g. ports
- 10. a) State two types of computer output devices. (2mks)**
- Screen (monitor)
 - Printer
 - Speakers
 - Plotter
 - Micro forms

- b) **State a situation where real time processing would be appropriate.** (1 mk)
- In hospitals
 - In Banks (ATMs)
 - In Chemical plants
11. **State three functions of the central processing Unit (CPU).** (3 mks)
- To perform all the processing including all computations
 - To control sequence of operations
 - To give commands to all parts of the computer system
 - To control the use of the main memory storage to store data and instruction.
12. a) **Explain the difference between a system software and application programs.** (2 mks)
- Application software handles the job of the end user
 - system software helps in controlling and assisting in performance of the computer system
- b) **Explain the difference between digital and analogue computers.** (2mks)
- Digital computers represent data in form of discrete values i.e. in binary Form
 - Analogue computers represent numbers in form of strengths of electric current Output is in form of smooth graphs.
13. a) **Explain the difference between Random Access Memory and Read Only Memory** (2mks)
- RAM offers temporary storage of data and programs
One can read from it and also write to it
 - ROM provides permanent or semi-permanent storage only. Contents can be read but not rewritten during normal computer operations.
- b) **State in which memory the monitor program would be stored** (1mk)
- ROM
14. **State the two requirements of computer program testing** (2 mks)
- Compiler
 - Test data
15. For each of the following file organization methods, state an appropriate storage medium.
- a) Serial- magnetic tape
 - b) Random- Compact disk/Magnetic disk (2mks)

SECTION B (60 MKS)

16. Students sat for a test in computer studies. The table below gives the marks obtained and the number of students obtaining the marks.

Write a program in a structured high level language to calculate the mean of the result.

The formula for the mean is given in the table below. (15 mks)

Marks obtained (x)	Number of students (F)
11	1
16	2
21	6
26	5
31	10
36	6
41	2
46	2
51	1
56	1

$$\text{Mean} = \frac{\sum fx}{\sum f}$$

Formula for the mean:

Program Mean (inpt, output):

```
Var
Stno, mar, Total, I, n, f, sum: integer;
Mean, average: real;
Begin
Writeln ('Enter the number of entries');
Readln (n);
Sum: =0;
F: 0;
For i: = n do
Begin
Writeln ('enter the students Mark followed by the frequency');
Readln (mark *stno);
Sum: =mark *stno;
Sum: =sum +Total;
F: f + Total;
F: f+ stno;
End;
AVERAGE: =; AVERAGE: 5: 4);
Readln
End.
```

17. a) **Briefly explain the following terms:**
- i) Cell – Intersection of row and column in a spreadsheet
 - ii) Range – A group of cells
 - iii) Label- text with no numerical value.
 - iv) Value- constant, a number value
 - content of a cell
 - v) function- A computation that is predefined by an electronic spreadsheet
- b) A spreadsheet has the following entries:

	A	B	C	D	E	F	G
1	PROJECTED BUDGET						
2	Percent	10.0%					
3							
4	ITEM	1996	1997	1998			
5	Food	56,000					
6	Clothes	24,000					
7	Fees	50,000					
8	Transport	20,000					
9	Entertainment	15,000					
10							

Provide a formula for cell C% that can be copied onto cell D5 and the range C6.. D10 to give a uniform increase of 10% of the previous year's value for each item. (3mks)

=B2\$ * C5

- c) **State two advantages of word processors over manual typewriters (2mks)**
- formatting and editing is easy
 - has punctuation and style checking capability
 - Allows one to custom document printing needed
 - Has built in dictionary for spell checking
 - Offer alternative words. (Thesaurus)
- d) **List three formatting features of word processor (3mks)**
- Moving and copying text
 - Cursor movement
 - Find and replace
 - Inserting and overtyping
 - Deleting text
 - Overtyping

- e) **Explain the difference between the printing of multiple copies and the printing of multiple pages**
 -Multiple copies refers to one document repeated several times
 -Multiple pages refers to different pages being printed
- 18 a) **State any three reasons why people may resist the introduction of computers at their place of work (3 mks)**
 ○ Losing their job (retrenchment)
 ○ Fear that their juniors may become their seniors i.e. change in power structure
 ○ Some people are not ready to be retrained
 ○ Fear that information will now be available to everyone
- b) **Explain the difference between data privacy and data security. (4mks)**
 - Data privacy is where personal information, which one would not like to share with others, raises concern
 - Data security is prevention of unauthorized access to information.
- c) **State two operational methods of an organization ensuring of data. (2mks)**
 -Physical measures e.g. locking
 -Access code e.g. passwords.
 -Data encryption i.e. data is jumbled up before transmission and decoded at the receiving end.
- d) **Explain the use of computers in health care (6mks)**
 -Research i.e. when doing research about medicine
 -Diagnosis e.g. passwords
 -Administration e.g. staff and patient records
 -Treatment
 -observation
19. a) **i) Define normalization. (2mks)**
 -This is a step-by –step process of removing redundancies and creating tables that do not have repeating groups.
- ii) State three objectives of normalization. (3mks)**
 -Minimizing data redundancy.
 -Establishing dependences between items and grouping them in a most effective manner
 -Ensures data independence to the extent one would wish.
- b) **i) What is a distributed system? (3mks)**
 -This is a decentralized way of data processing. Databases are shared.
- ii) State any three advantages of distributed systems. (3mks)**
 -Databases are shared
 -There is no need of a big central computer
 -Processing is fast since people process their own work.

c) **State any four criteria for choosing an operating system** (4 mks)

- Hardware design and basic design of the computer.
- Security
- Application intended for the computer
- Method of communicating with the computer i.e. many or few peripherals
- Efficiency

20. a) **Match the computer generation with the technology used to make the**

Processor

Generation

Technology

Third

Thermionic valves

First

Integrated circuits

Fourth

Transistors

Second

large-scale integration (4mks)

b) **Draw a block diagram showing the functional units of computer hardware.**

Name the units. (6mks)

c) i) **list three types of secondary storage media.** (3mks)

- Magnetic tape
- Magnetic disk
- Optical disk

ii) **State one advantage and one disadvantage of a laser printer** (2 mks)

Advantages

- It's fast
- It's not noisy

Disadvantage

- Can not do multiple printing.
- It's very costly

COMPUTER STUDIES

(THEORY)

Oct./Nov. 1999

2 ½ hours

Marking scheme

SECTION A (40 MARKS)

1. **State any three functions of a computer** (3 mks)
 - Storage
 - Processing
 - Data capture e.g. scanning
 - Communication e.g. email
2. **Give two types of storage devices used in a computer giving an example of each.**
 - Primary storage devices e.g. RAM, ROM
 - Secondary storage devices e.g. hard disk, Magnetic Disk, CD-ROM drive
3. **Give any three precautionary measures considered to ensure the safety of computers in a computer laboratory.** (3 mks)
 - Burglar proof doors
 - Avoid computers in basements to safeguard against flooding
 - Constant cleaning to minimize dust(3 mks)
4. **Define**
 - a) File- a group of related records
 - b) record- a group of related fields
 - c) Field- the individual units that make up a record e.g. name, NSSF
No. Gender (2 mks)
5. **List two features of word processor** (2mks)
 - Word Wrap
 - Spelling and grammar
 - Editing
 - Formatting
6. **Differentiate between the hardware and software components off a computer giving an example of each.**

Hardware – the physical parts of a computer e.g. Mouse, keyboard
Software – the programs/ Instructions in a computer
7. **What is program documentation? Give two examples of program documentations.** (3 mks)

This refers to information that serves to explain the purpose of a program.

Documentation may be internal – in the form of comments and appropriate named variables and constants e.t.c. or may be extended in the form of a written description and structure diagram. E.g. user oriented and program oriented.

8. Give two differences between high-level and low-level languages.(2 mks)

- | High Level | Low level |
|--|---|
| 1. Instructions are written in English like syntax | 1. Instructions are written in machine code or near machine code. |
| 2. Easy to learn | 2. Difficult to learn |
| 3. Requires compilation | 3. Does not need translation
Except in assembly language |

9. Worksheet cells are referenced using the column letter and row number e.g. D2 is cell in column D and row 2.

Use the sample worksheet provided to answer the questions below

	A	B	C	D	E	F
1	Month	Jan.	Feb.	Mar.	April	Total
2	Fees	460	460	460	460	
3	Food	300	350-	305	270	
4	Electricity	100	100	100	100	
5	Fuel	150	150	150	150	
6	Transport	380	270	150	300	
7	Total					

- a) Write down the data type that is stored in cell C5 (1mk)
-what cell contains the data items representing transport for the month of February? (1mk)
- b) What cell contains the data items representing transport for the month of February? -c6
(1mk)
- c) Write down the formula that may be used to compute the total in cell f6. (1mk)
-sum (B6: E6)

10. Name any two types of graphs that are supported by spreadsheets.(2 mks)

- Pie charts
- Line graphs
- Bar graphs

11. What is relational database? (2mks)

- a database where records are structured within tables (relations)

12. As regards to communication within a computer network, what do you understand by the following terms: (2mks)

- i) Point –to–point – a dedicated line of communication is first established before communication can take place
- ii) Broadcast – information is sent any device on the network can receive it e.g. Hub.

13. Give any two types of data entries that may be input into a worksheet cell. (2 mks)

- Numeric (Number)
- text
- formulae
- date

14. Give any two functions of a System Analyst

- Studies current system
- Gives proposals on new systems
- assists to design and implement new systems

15. List any three program control structures used in programming. (3 mks)

- sequencing
- Decision
- Iteration

SECTION B (60 MARKS)

Answer question 16 and any other three questions

16. The roots of the equation $ax^2 + bx + c = 0$ are by the formula

$$X = \frac{-b \pm \sqrt{b^2 + 4ac}}{2a} \text{ and } a \neq 0$$

a) Draw a flowchart to compute the roots of the equation. (10 mks)

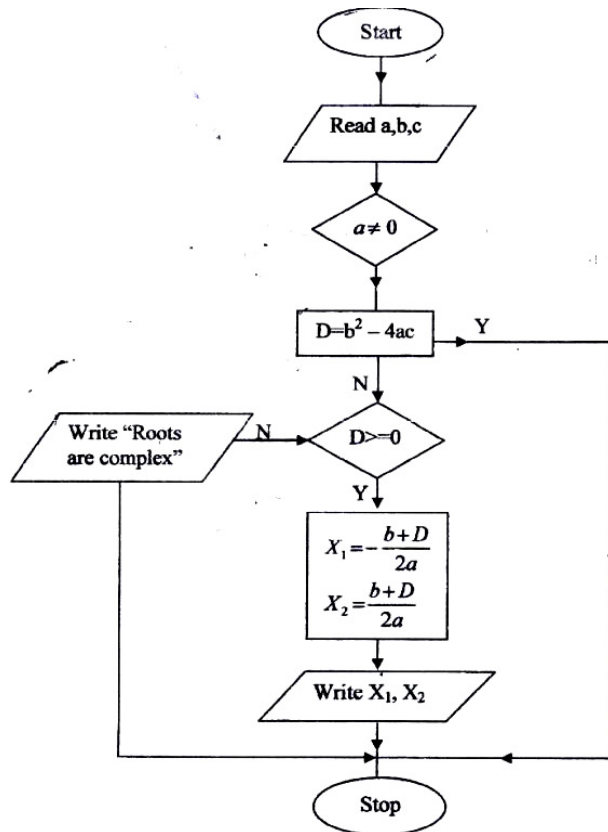

b) Using the flow-chart write a program that will compute the roots and if $b^2 - 4ac$ is negative, the program should display the message "NEGATIVE" (5mks)

Program roots (input, output)

{ a program to calculate the roots of a quadratic equation var

A, b, C: INTEGER:

X, y: real;

Begin

Writeln ('enter the values of a, b and c');

Readln (a, b, c):

17. A multinational organization has offered to donate computers to your school. The Board of governors has requested you to advise on the operating system to be used by providing answer the following questions.

a) **What is an operating system?** (1mk)

-system software that controls the computer system (hardware and other application software)

b) **State and briefly explain an two types of operating systems. (6mks)**

- Single uses/single tasking- support one use at a time and one program at a time e.g. Dos

c) **Briefly explain any four functions of an operating system. (8mks)**

- Task scheduling, arranging and organizing of tasks (jobs 0 under a system of priority.

-Interrupt handling, a computer instruction that momentarily stops the normal operation of a routine. The operation can usually be resumed later from the interruption

o I/O management

18. i) **State one area where computers are used.** (2 mks)

- Medicine
- Industries
- Retails stores
- Research

ii) **Give any two advantages of using computers in this area(4 mks)**

Any two areas in any of the above areas

b) **Explain the effect of computers technology in the following areas:**

i) Job opportunities

- Creation of new jobs in such areas such as networking, database management.
- Loss of jobs for employees with routine jobs and repetitive tasks.

ii) Job Skills

- new skills (experts will be required therefore employee training will be required

iii) Communication

- Easier to communication e.g. email, chatting (9 mks)

19. A computer Vendor has recommended the use of a computer database to your school for student information

a) **Explain to the Board of Governors what a database is an its functions (5mks)**

A database is a shared collection of logically related data (and a description of this data) designed to meet the information needs of an organization.

- The collection is integrated to reduce data replication
- The collection contains its description called schemas
- The collection is managed in such a way that it can fulfill the different needs of its users.

b) Give two examples of database systems (2mks)

Billing system
Education Management system
Hospital system
Etc.

c) Briefly explain any two advantages and two disadvantages of using a database (8 mks)

Advantages

- control of data redundancy
- Promotes data consistency
- There is sharing of data
- Improved security
- Increased concurrency

Disadvantages

- Complexity
- Extra cost of hardware and software

20. a) What is a computer network topology?
- Arrangement of computers on a network

b) Using appropriate diagrams, show any three computer network topologies (9mks)

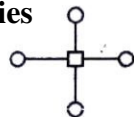

Star

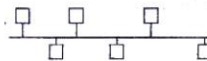

Bus

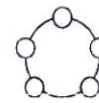

Ring

c) Briefly explain two reasons why organizations need to network their computers. (4 mks)

- Sharing of information and other resources like printers, internet
- Fault tolerance. It is safer to have several copies/services of work spread in a network
- Economy of scale. Cheaper to have a network than a centralized system
- Communication e.g. email, chatting etc.

- Scalability, it is cheaper to add computers on a network than to do an upgraded

COMPUTER STUDIES

(THEORY)

OCT. /NOV. 2000

2 ½ HOURS

SECTION A (40 MARKS)

Answer all the questions in this section.

1. Write the following abbreviations in full. (3 mks)
 - i) BCD -Binary Coded Decimal
 - ii) ASCII -American Standard Code for information Interchange
 - iii) EBCDIC -Extended Binary Coded Decimal Interchange Code
2. Define the term array as used in computer programming. (2mks)

-An array is a structure, which holds many variables, all of the same data type. The array consists of so may element, each element of the array capable of storing one piece of data (variable)
3. Suggest how computers may in future be made more users friendly for persons that are: (2 mks)
 - a) Blind – computers that respond to touch and sound (voice)/Braille keyboard
 - b) Without hands – computers that respond to voice
4. State three advantages of computer networking
 - i) Sharing of resources/information (computers, printers, modem, internet etc)
 - ii) Provision of local facilities without the loss of central control
 - iii) Even distribution of work, processing loads etc.
 - iv) Stored risk and mutual support
5. Name six steps in program development cycle in their logical sequence. (3mks)
 - i) Problem definition
 - ii) Feasibility study
 - iii) System design
 - iv) System design
 - v) Programming
 - vi) System implementation and h/w configuration
 - vii) Operation and maintenance
6. State two methods of minimizing dust in a computer laboratory (2mks)

- i) Constant cleaning and mopping
 - ii) Use a carpeted floor (gathers dust slowly and does not raise dust)
 - iii) Users to remove shoes. This ensures that no dust is carried to the room.
7. **Differentiate between primary memory and secondary memory. (2mks)**
Primary memory refers to the storage capacity of the CPU. It holds data and instructions currently in use. Also stores immediate results from processing waiting transfer to the output devices. Primary memory is volatile, i.e contents held transfer to the output devices. Primary memory is volatile, i.e. contents held are lost on power loss.
- Secondary memory or backing storage** refers to the storage of programs and data files, not currently being operated on. Secondary memory is non-volatile or permanent, i.e. Contents held are not lost on power loss.
8. **List the steps that you would use to correct wrongly spelt words in a document using the spell-checking feature.**
- i) Start the spell checker e.g. f7 or click on tolls the spelling and grammar
 - ii) Use the spelling and grammar dialogue box to adjust the words as you wish
 - iii) Continue the process till the whole document is spell checked.
9. **Differentiate between single-user and multi-user operating systems giving an example of each. (3 mks)**
- Single user O/s – allows one user to operate one program at a time in an Interactive conversational mode e.g. MS-DOS
Multi-user O/S – Computer system can be accessed by several users or Applications simultaneously.
10. **Optical Mark Reader (OMR) (2 mks)**
- An OMR is able to sense marks on a special form in certain places. Application include multiple choice answers sheets, enrolment forms etc.

11. In the following flowchart, what will be the value of the sum when printed?
Show how you arrive at your answer

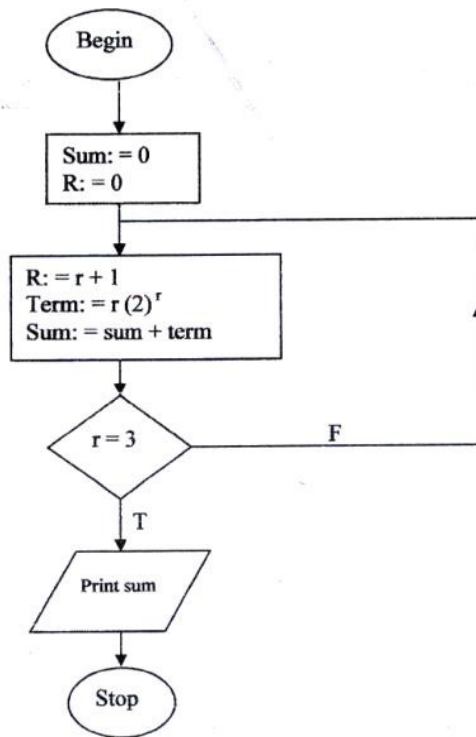

R	Term	Sum
0	0	0
1	2	2
2	2×2^2	10 (2 + 8)
3	3×2^3	34 (10 + 24)

Final answer is 34

12. **Distinguish between system software and application software. (2mks)**
 Systems software- Manages the operation of the computer itself. Examples are operation system, Assemblers, compilers
 Application software – handles the needs of the end-user e.g. general purpose packages like word-processors, spreadsheets etc.
13. **Explain any three of the terms: Creating, editing, printing and saving as used in word- processing. (3mks)**
 Creating –starting a new document
 Editing- altering contents of a document
 Printing- getting a hard copy of the typed document
 Saving – storing a document on secondary media
14. **List three file organization methods in a computer. (3mks)**
 Serial (heap)
 Sequential
 Random
 Indexed Sequential

15. What is the use of the search and replace feature in a word-processor. (2mks)

- i) To locate a particular word or character or text
- ii) To locate and replace the occurrence of a particular word/text or character with another

SECTION B (60 MARKS)**Answer Question 16 and Any Three Other Questions**

16. a program is required for reading in a student's name and scores obtained in two subjects. The output of the program will consist of the student's name, the two scores, the average of the two scores and comment. The comment is based on the average as follows:

Average	Comment
≥ 70	Good
< 70	Poor

Write a program to solve the problem using a high level language (15 mks)

```
Program marks (input, output);
Const
n=2;
var
stno, mark 1, mark2, total, i,f, sum: integer;
mean, average : real;
Name, comment: s string;
Begin
Writeln (Enter the student Name')
Readln (Name)
Writeln; ('enter the two students Mark's):
Readln (Mark 1, Mark 2)
Average: = SUM/n;
Writeln;
    If (average > =70) then
        Comment: = 'Good'
    Else
        Comment: = 'Poor',

Writeln ('NAME SUBJECT 1 SUBJECT 2 AVERAGE Comment');
Write (name: 6, Mark 1: 8, Mark 2:12, Average: 15:1, Comment: 14):
Readln
End.
```

17. a) **What is meant by data communication in a computer network?** (2mks)
- Movement of computer information from one point to another by means of electrical or optional transmission system. Such systems are often referred to as data communication networks
- b) **State what is meant by each of the following transmission media and give one advantage and one disadvantage for each.**
- i) **Twisted pair cables.** (3mks)
-Two single wires, each encased in colour coded plastic insulation, are twisted together to form a pair.
- Advantages**
- i) Low cost compared to coaxial and fibre optic
 - ii) Offers greater security than radiated media
- Disadvantages**
- i) Susceptible to EMI from nearby circuits (cross talk)
 - ii) Can not transmit over long distances
 - iii) Data transmission is slow compared to fibre and coaxial
- ii) **Coaxial cables**
-Consists of 4 parts: an inner conductor, which carries the signal, a protective plastic coating, shielding and outer insulation.
- Advantages**
- i) Secure in terms of data transmission
 - ii) Is not affected by EmI
- Disadvantages**
- i) Can only transmit data over short distances
- iii) **Optical fibre cables**
Cable consists of thin strands of transparent and translucent glass through which light/laser/LED is transmitted. The light is guided through the cable by internal reflection.
- Advantages**
- i) Expensive to implement
- c) **List four network elements in a local area network** (4mks)
- i) A server
 - ii) Workstations
 - iii) Software/protocols
 - iv) Cabling

18. **Andrew, Jane, David and Zablon had tea, sausages and bananas for breakfast.** They took one sausage, two sausages, three sausages and one sausage respectively. In addition, they took a cup of tea and two bananas. Tea, sausages and bananas cost Kshs 10, 15 and 5 respectively.

By naming columns A, B, C ... and rows 1, 2, 3

- (a) **Construct a worksheet showing the above information (7mks)**

	A	B	C	D	E	F
1				BREAKFAST CLUB		
2		ITEM	SAUSAGES	TEA	BANANA	TOTAL COST
3	NAME	COST	15	10	5	
4	Andrew		1	1	2	35
5	Jane		2	1	2	50
6	David		3	1	2	65
7	Zablon		1	1	2	35
8						
9						
10						

- (b) **State the expression you would use to obtain:**

(i) **Total expenditure by David**
 = C6 * \$C\$3 + D6*\$D\$3 + E6*\$E\$3 (4mks)

(ii) **Total number of sausages taken** (2mks)
 = sum (C4: C7)

(iii) **The cost of the cheapest item** (2mks)
 = Min (C3: E3)

19. (a) **What are computer viruses?**

A computer program designed specifically to damage other programs or cause irregular behaviour. A virus itself from one computer to another

- (b) (i) **State two ways through which computer viruses may be controlled** (2mks)

- Using an up to date antivirus
- Prude management policies & procedures e.g. restricting the movement of diskettes.

- (ii) **Explain how each of the two ways stated in b (i) above assist in controlling computer viruses.** (2mks)

- Antivirus software that is resident in the computers memory will detect a virus before it can affect the system. However the antivirus must be continuously updated to be effective.
- Good management policies will ensure that the movement or transfer of virus programs is reduced to a minimum. Policies include:
 - ◆ Restriction of movement of diskette
 - ◆ Write protecting diskettes
 - ◆ New software on disk should be evaluated
 - ◆ Having a fire wall

(c) Define each of the following computer terminologies (3mks)

- (i) Byte- a combination of consecutive bits typically 8 bits
- (ii) Bit- smallest unit of data representation. A binary digit, 0 or 1
- (iii) word- A group of bits treated as separately unit of data by the control unit is called a WORD. WORDS may be sub divided into bytes, which normally correspond to character.

(d) Convert the hexadecimal number FCI to its binary equivalent (6mks)

20. (a) A firm intends to purchase new software. List three items that should accompany the software (3mks)

- (i) Installation guide
- (ii) Service/ maintenance contract
- (iii) A reference Manual (Documentation)
- (iv) A license
- (v) A user guide
- (vi) Training

(b) State and explain three ways that computer technology could make office work more efficient. (6mks)

- (i) Powerful easy to use software enables employees to analyze large amounts of data at their desks at high speeds.
- (ii) Accuracy- Once fed with the correct data and instruction given a computer never makes errors normally.
- (iii) Diligence- a computer never gets tired or bored if it has to do the same job over and over again.
- (iv) Automation – Once an instruction has been give, a computer can carry on its job automatically till it is complete.

(c) Explain the meaning of each of the following computer crimes:

- (i) Hacking- the invasion of the privacy of a system
- (ii) Fraud- refers to the use of computer technology to falsify records, steal money etc.
- (iii) Piracy- This is the illegal acquisition and distribution of computer material purporting it to be original. Piracy is therefore a violation of copyright laws

COMPUTER STUDIES

Oct/Nov. 2001

2 ½ Hours

Paper 1

(THEORY)

SECTION A. (40 MARKS)

Answer all the questions in this section

1. Compare the two types of diskettes used in microcomputers in terms of physical size and densities.

- 3 ½ Floppy diskette, smaller in size hold more data
- 5 ¼ floppy diskette, larger in size, holds less data

2. Why is it necessary to have a UPS in a computer laboratory?

- To regulate amount a voltage entering computer equipment
- To supply equipment with power temporarily while normal power is not available

3. (a) Explain what is meant by batch processing (1mks)

- Transaction are accumulated over a period of time and then processed at a pre-specified time to produce a batch of output

(b) Give one advantage and one disadvantage of batch processing (2mks)

Advantages

- Simple to develop
- Timing of the reports is not necessary

Disadvantages

- Time lag between origination of the transactions and the information availability
- Late information is not suitable for situations where instant decisions are required
-

4. List any four high level programming languages (2mks)

- Visual basic - Basic
- Pascal - Java

(Any programming language that uses English like syntax)

5. A 3 by 4 matrix M is to be added to another 3 by 4 matrix array N so as to give a third 3 by 4 matrix array P. Using a high level programming language, write a program segment that assigns the sum of M and N to P.

Program add matrix (input, Output);

Type

Matrix = Array (14, 13) of integer;

Var

A, B, C: Matrix;

I, J: Integer;

```

Producer add (Var X, Y, Z: Matrix);
Begin (add)
For I: to 3 do
Begin
For J: 1 to 4 do
Z [I,J]: X [I, J] + Y[I,J];
End
End; {add}

```

6. The first column in the table below contains the formulae as stored into the cell F10 of a spreadsheet. Enter the formulae, as they would appear when copied to the cell M20 of the same spreadsheet.

Formula in F10	Formula in M20
= D10 * E10	=K20*L20
=A\$25	=H\$25
=\$D\$13	=\$D\$13

7. Give three advantages of separating data from the application that use the data in database design (3mks)
- There is data independence i.e. one can make changes to the underlying table structures without changing the end- user's views
 - There is improving security and privacy. The end user only sees what is relevant
 - There is improved productivity in from data independence
8. Explain the impact of information on organizations in each of the following areas:
- (a) Competition
- An organization that has access to quick and relevant information will obviously be ahead of its competitors and can therefore strategize itself accordingly. Information is a powerful tool in a competitive environment
- (b) Pace of growth
- Organizations need to advertise themselves therefore information is a very important ingredient to their pace of growth. An organization that advertises itself accordingly will be known and will therefore be ahead of its competitors.
9. (a) List any four tasks that an electronic spreadsheet should be able to perform other than calculations.
- Production of graphs
 - Automatic recalculation
 - Projection of growth curves through what if analysis
 - Sorting of data
- (b) Explain what is meant by automatic recalculation as used in a spreadsheet

- Feature of electronic spreadsheet system which runs anytime a cell is updated, causing all formulas, functions and macros which depend on that cell to automatically update their computations

10. Describe the functions of the following computer hardware components:

(a) Mouse

- This is an input device that works in conjunction with a pointer on the screen. It is used for selecting and other input functions.

(b) Scanner

- This is an input device that works with Optical Character Reader Technology to capture data (text and images)

11. (a) State two differences between Disk Operating System (DOS) and WINDOWS operating system.

- DOS is command driven while Windows is GUI driven
- DOS is difficult to learn and use while Windows is easier to learn and use.

(b) (i) Define the term application Software

- Software with a specific function, such as word processor or game. It is meant to benefit the end user.

(ii) Give one example of application software (1mk)

- Word processor e.g. Ms Word
- Spreadsheet e.g. Ms Excel

12. (a) Give one difference between internal and external commands in Disk Operating System (2mks)

- Internal DOS commands are part of a file called command that stays resident in memory (RAM)
- External DOS commands are stored on secondary storage and are only loaded onto RAM when required

(b) Name two DOS commands that may be used for checking disk errors (1mk)

CHKDSK, SCANDISK

13. Explain how a paragraph can be removed from one place to another in word- processing (2mks)

- Highlight/ select the paragraph
- Click on edit then cut
- Click on the new area then click on edit then paste

14. Define the term structured programming (2mks)

- A program is broken down into smaller sections called modules. The modules are linked together.

SECTION B (60 MARKS)

Answer questions 15 and other three questions from this section

15. (a) What is meant by each of the following terms:

(i) Pseudo code (1½Marks)

- Pseudo code (or structured English) describes module design in words using syntax like programming language. It aims at proving programmers with clear and unambiguous process specification.

(ii) Flowchart

- A flowchart is a diagrammatic or pictorial representation that illustrates the sequence of operations to be performed to get the solution of a problem.

(b) A program is required to list the first 1000 numbers in the series 2, 4, 6, 8, 10 Draw a flowchart and write a program that can carry out this task (12mks)

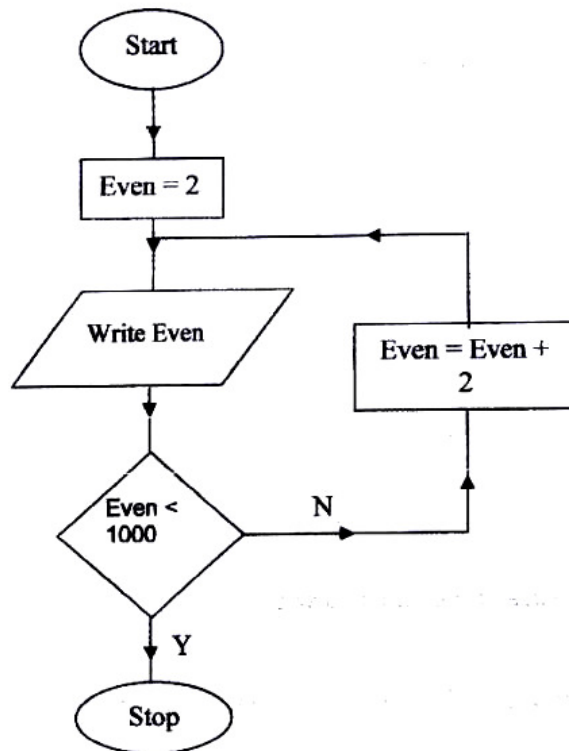

```
Program ListEven(Input, Ouput);  
Var  
    Even:Integer;  
Begin  
    Even:=2;  
    Repeat  
        Write(Even);  
        Even:=Even + 2;  
    Until Even > 1000;  
End.
```

16. The following car details are to be entered in a database: Make, date of manufacture, colour and cost.

(a) Prepare a suitable database structure showing field names and their field types (5mks)

Field	Data type
Make	Text
Date of manufacture	Date
Colour	Text
Cost	Currency or Number

- (b) **Explain how you index the data such that cars of the same make and colours are together.** (2mks)

Make the primary key in the main file be the same as that in the indexing file

- (c) **Write statements that can be used to select cars of the colour green** (2mks)

	Make	Date of manufacture	Colour	Cost
Expression			Green	

- (d) **Give an instruction that would:**

- (e) (i) **Select cars whose lie between 500,000/= and 1,000,000/=(3mks)**

- Between 500,000 and 1,000, 000

- (ii) **Determine the average cost of all cars** (3mks)

- Average {cost}

17. (a) **The diagram below represents the essential features of a computer system. Study the diagram and answer the questions that follow:**

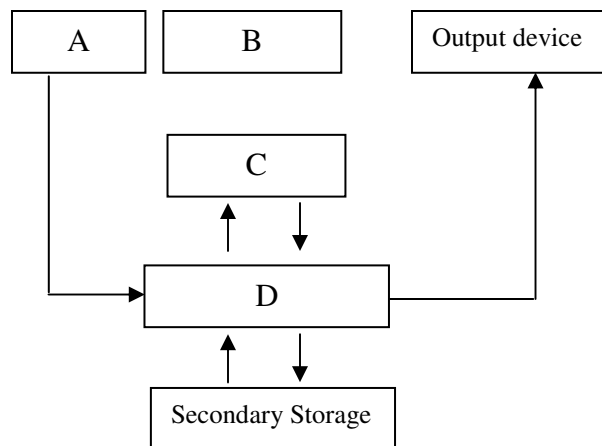

- (i) **Name the components:** (4mks)

- A. Input
- B. Control Unit
- C. Arithmetic Logic Unit
- D. Primary storage

(ii) On The diagram above, indicate the direction of data flow using arrows (3mks)

(b) Name the three types of buses in a computer system (3mks)

- Data Bus
- address bus
- Control Bus

(c) Explain how the CPU registers may be used to carry out a basic calculation such as (4mks)

$$2 + 7 = 9$$

- The data 2 and 7 are fetched from memory (RAM) and placed in the Data register (DR) via the memory Buffer Register and the Address register.
- The instruction + (add) is also fetched from memory (RAM) and placed in the instruction register (IR) via the address register.
- The IR decodes the instruction and sends out the necessary command to process the data in the DR.
- Results are then taken back to the RAM

(d) Name two computers output devices (1mk)

Monitors, Speaker, Printer

18. (a) State three ways in which computer technology may affect employment patterns in organizations

- Job replacement
- Job displacement
- Job creation

(b) State and explain three reasons why the employments patterns are affected

(6mks)

- Job replacement- Manual jobs can be done by a computer
- Job displacement- Some employees will find themselves being taken to other departments
- Job creation- Skills will be required for IT personnel in such areas as networking and database management.

(c) Suggest three strategies that can be employed to manage resistance to change (3mks)

- Involve the employees concerned when trying to introduce a new system
- Train the employees in the new system
- Inform the employees in organization plans
- Introduce the new changes in planed order e.g. in phases, in pilot states etc.

- (d) **Give three advantages of computerization in an organization**
- IT may cut down on costs e.g. labour cost, storage etc
 - IT provides timely and accurate reports that are crucial for decision making
 - IT provides for easy management of an organization's data and information e.g. easy retrieval of data
 - IT may result in overall increase in productivity

19. (a) **In a computer based information system, state the purpose of the following files and give one example where such a file may be required in a school (8mks)**

(i) **Report file**

- A summary file from the main file

(ii) **Backup file**

- Backup also called a security file – are copies of files kept in case the original master file is damaged or lost and cannot be used.

(iii) **Reference file**

This is a file with a reasonable amount of permanency. Examples of data used for reference purposes are price list, tables of rate of pay, names and addresses.

(iv) **Sort file**

This is a temporary file that holds records organized in a particular order

(b) **State three precautions that should be taken to ensure that diskettes are well stored (3mks)**

- Avoid physical damage
- Avoid bringing diskette close to magnetic fields
- Write protect to prevent accidental infection by viruses
- Do not eject from computer when the access light is still on

(c) **Distinguish between “serial” and “indexed sequential” file organization methods (2mks)**

A heap file, sometimes called a pile or serial file is the simplest type of file organization, records are placed in the file in the same order as they were inserted

An index structure is associated with a search key and contains records consisting of the key value and the address of the logical record

A sorted data file with a primary index is called an indexed sequential file

The file containing the logical records is called the data file and the file containing the index records is called the index file. The values in the index file are ordered according to the indexing field.

(d) Distinguishing between binary and octal number systems and give an example of each (2mks)

- Binary number consists of the digits 0 and 1 e.g. 100011_2
- Octal numbers consist of eight digits, 0,1,2,3,4,5,6 and 7 e.g. 127_8

COMPUTER STUDIES

Paper 1

(Theory)

2 ½ hours

2002

Section A (40 marks)

Answer all the questions in this section

1. **Describe the purpose of each of the following computer functional units**
 - (a) Control- Essentially governs all the computer activities and monitors the execution of programs.
 - (b) Storage – To holds internally before and after processing. Divided into two i.e. primary and secondary
Primary holds data and information being handled by the CPU. Secondary stores data and information in a more permanent form

2. **Explain how each of the following would affect the suitability of a room for use as a computer room.** (2mks)
 - (a) Burglar proofed door- enhances the security system as it prevents Unauthorized users from entering

 - (b) Availability of taps and sinks in the room – Could be detrimental since water can cause damage to computer equipment (3mks)

3. **State three data representation codes used in computers**
ASCII- American Standard Coded for information interchange
BCD – Binary coded Decimal
EBCDIC – Extended Binary Coded Decimal interchange Code

4. **State two types of documentation in program development and give the purpose of each** (4mks)

User Oriented –	Includes format of input required e.g. Source documents, how to produce outputs, how to run the program etc
Operator oriented –	Description of main action of the programs file specifications, restrictions, limitations, text references.
Program Oriented -	Program design using structure charts/ flow charts testing procedures (including test data and expected output)
Identification-	Includes of program, short statement of its functions, author, date written language used and version and hardware requirements.

5. **Suppose an element array A contains the values 9, 12, 17, 7 and 20. Find the value in A after executing the loop below:**
 Repeat for k= 1 to 4
 Set A {k + 1} = A {k}
 {End of loop}
- First time A {2}: = 9
 Second time A {3}: = 9
 Third Time A {4}: = 9
 Fourth time A {5}: = 9
6. **State any three activities that occur in a program compilation process**
(3mks)
- Program code converted into machine language
 - Program is debugged (checked for errors)
 - Executable format of the file is created
7. **The Formula = k20 + p \$18 was typed in cell L21 and then copied to cell M24 of a spreadsheet. Write the formula as it appears in cell M24** (2mks)
 = L23 + Q\$18
8. **State two ways in which a computer may be used in efficient running of a hospital**
(2mks)
- storing patient records
 - Monitoring patients e.g. babies in incubators, ICUs etc
 - Diagnosis, data from sensors attached to the patient can be fed into a computer e.g. in heart ailments, CAT and MRI scans
 - Medical training e.g. using simulations software to show how a body part works
9. **List three disadvantages of using traditional file management method**
(3mks)
- Separation and isolation of data
 - Duplication of data- same data stored in different departments/ locations
 - Data dependence – when a change occurs it must be made in all other related departments that it affects.
 - Incompatible file formats since data is stored in several places
10. **Give one disadvantages of a single processor multi- user system (1mk)**
- The processor gets overloaded due to several time slices

11. List three differences between a microcomputer and a super – computer (3mks)

Microcomputers	Supercomputers
1. Small in size	1. Huge in size
2. Low speed compared to Supercomputers	2. Fast processing capacity
3. Intended for use at home or Offices for normal application Like WP	3. Mainly used in scientific and engineering application e.g. weather forecasting
4. Low cost compared to supercomputers	4. Very expensive

12. State and explain two reasons why word processing is one of the most common applications of many computer users.

- Text can be edited (changed) on screen and reprinted if mistakes are made
- WP has many features which can be used to format the document to look presentable
- WP has a spell checker that makes it easy to correct and insert alternate words

13. Write – 1 in twos compliment notation in byte form (4mks)

$1_{10} = 1_2$ in byte form it becomes 00000001_2

One's complement is 11111110_2

Two's complement is 1111111_2

14. Explain the following input/ output terms as used in computer systems. Give an example for each (4mks)

- (a) Read- get data from memory e.g. opening a file
- (b) Write – put data into memory e.g. saving

15. State two disadvantages of networking

- The cost of installation is very high
- A network manager is required to run the system
- If the server fails, all the workstation could be affected
- Since data is shared, there is greater need for security

SECTION B (60 MARKS)

Answer question 16 and any other three questions from this section

16. The following flowchart can be used to list the odd numbers between 0 and 100

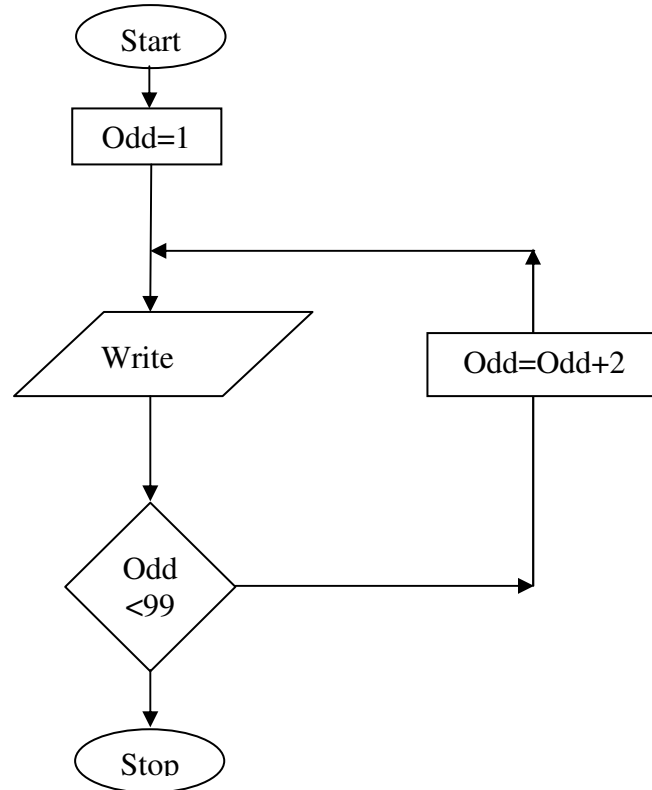

- (a) Write a program segment for the flowchart using a high level language (7mks)

```
Program list
Var
Odd: integer
Begin
Odd; = 1,
Repeat
Write (odd);
Odd: odd + 2
Until odd>99;
Readln
End.
```

- (b) What would be the output from the flowchart if the statement in the decision box is changed to:

- odd = 100 program will run continuously without stopping
- Odd < 100- only 1 will be displayed
- Odd > 100 – 1- 99 will be displayed

- (c) **Modify the flowchart so that it prints only the sum of the odd numbers between 0 and 100** (5mks)

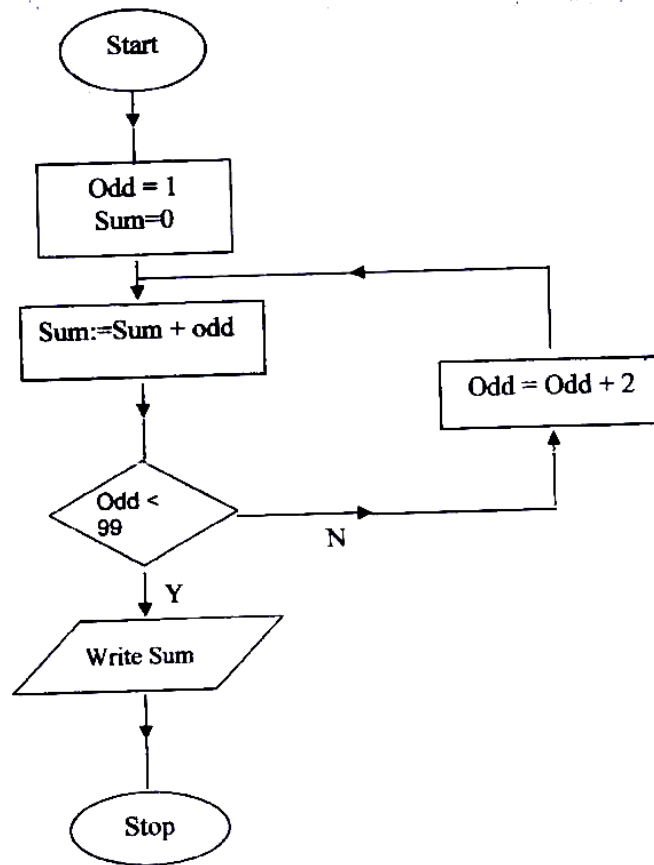

17. (a) **List five precautions that can be taken to protect data stored in diskettes** (5mks)

- Avoid keeping in places of high temperatures
- Avoid folding/ crushing/ dropping/ (any physical damage)
- Avoid bringing close to magnet/ electrical fields
- Keep in disk bank
- Write protect
- Keep away from dust
- Do not remove while the disk drive is active
- Install an up to date antivirus

- (b) **State and explain two precautions that be taken to help recover data lost through accidental erasure**

- Keeping backup copies
- Use of recovery tools e.g. unformat/ undelete

- (c) **Describe each of the following data processing methods (6mks)**
- (i) Batch processing – transactions are collected and the processed at a pre-specified time. Once processing begins no amendments can be made.
 - (ii) Distributed processing- Data processing where computations and data storage are spread out geographically among the computers on a network
 - (iii) Multiprogramming- Running of two or more programs simultaneously

18. (a) (i) **What is a computer keyboard? (1mk)**
- Input device with keys for keying in data in the form of characters
 - List four types of keys found on a computer keyboard. Give an example of each. (4mks)
- Alphanumeric
Function
Numeric key pad
Special character
Cursor control

- (b) **give four differences between present days' computers and the older generation of computers (4mks)**

Present day computers	older day Computers
- Smaller in size	- Bigger in size
- Faster processing speed	- Slower processing speed
- Higher storage capacities (RAM and Hard Disk)	- Smaller storage capacities (RAM and Hard Disk)
- Lower cost	- High cost

- (c) (i) **State three advantages and one disadvantage of using a laser printer**

Advantages

- Fast
- Quiet
- Quality printout
- More fonts

Disadvantages

- Can not do carbon printing
- Can not use continuous sheet
- High cost of purchase

- (ii) **Distinguish between a line printer and page printer**

- A page printer prints one page at a time while a line printer prints one line at a time.

19. (a) Identify three public Universities and three National polytechnics in Kenya where further computer training is offered, In case state the highest level of qualification that can be acquired in computer training.

Nairobi University	-	Masters
Kenyatta University	-	Degree
Moi University	-	Degree
JKUAT	-	Masters
Maseno	-	Degree
Egerton	-	Degree
Kenya polytechnic	-	Diploma
Mombasa polytechnic	-	Higher Diploma
Kisumu polytechnic	-	Diploma
Eldoret polytechnic	-	Diploma

- (b) Distinguish between “job replacement” and job displacement” in references to computerization

Job replacement – loss of job

Job displacement – Change of job but same company

- (c) Give four reasons why a firm may decide to computerize its operation

- High quality products/ services
- Better decision- making
- Cut down on costs/ labour
- Compete effectively
- Timely computations of tasks
- Enjoy benefits of global markets
- Sharing information
- Reduce redundancy

- (d) An individual has a right to demand guarantee to privacy of personal information stored on a computer

Give three such types of information

- Bank accounts records
- Income tax records
- Medical records
- Legal records
- Bio- data
- Property records

20. (a) Give three comparisons of the traditional file management method of typing a document on a typewriter against using a word processor (6mks)

Word Processor

- Less dependent on paper
- Much economical in storage

- Easy/ fast to retrieve
- Easy to mail
- Easier to edit
- Has mail merge and other facilities

(b) (i) Define the term spreadsheet (1mk)

- A program in which the main memory of the computer is divided into rows and columns. The intersection of a row and a column is called a cell.

(ii) Give two examples of spreadsheet packages available in the market today

(2mks)

- MS-Excel Lotus 1-2-3
- Super Calc Quattro Pro

(c) Explain the following terms as used in a spreadsheet:

- (i) What ifanalysis (2mks)
- (ii) Cell- The intersection of a row and a column. The point of data entry (1mk)
- (iii) Formula- A mathematical expression that combines cell references using arithmetic symbols (1mk)
- (iv) Pie Chart- A graphical object for displaying information using sectors or a circle (2mks)

COMPUTER STUDIES

Paper 1

(THEORY)

Oct. /Nov 2003

SECTION A (40 MARKS)

1. **Computer systems are built from three types of physical components: processors, memories and I/O Devices.**

(a) **State two tasks of a processor** (2mks)

- (a) To control the use of main memory to store data & instructions
- (b) To control sequence of operations
- (c) To give instructions to all parts of the computer system
- (d) To carry out processing

(b) **State the functions of I/O devices**

Input – Used to enter data into the computer in a form the computer can store & process e.g. keyboard, mouse.

Output – Used to display the results of processing e.g. printer, monitor

2. **Threats to the safety of computer systems take many forms such as: White-collar crime, natural, disasters, vandalism and carelessness.**

- Give one way as to how each of these forms of threats can be controlled

(i) **White Collar Crime-** Enforce personnel security e.g.

- No one person should be wholly responsible as system administrator

- Introduce computer audit trails

- No one person should be in one department for a long time. Purge employees

(ii) **Natural Disasters**

- Floods, computers rooms should not be installed in basements

- Lightning, Use UPS, surge protectors and the like

(have backups that are well kept safely away from the computers site, have a contingency plan).

(iii) **Vandalism**

- Enforce personnel security e.g. restrict building access

- Secure computer systems to desks, reinforce doors, windows

- Introduce alarm system, CCTV systems

(iv) **Carelessness**

- Avoid food, drinks into the lab

- Have backups in case of unintended delete operations

- Have undelete utilities

3. (a) **Explain the term nibbles as used in data representation in computers**

- A nibble refers to a half a byte or 4 bits (A byte is equivalent to 8 bits)

(b) Perform the following binary arithmetic giving the answers in decimal notation

(i) $1110.0111 + 1101001.011$ (3mks)

1110.0111

$$\begin{array}{r} 1101001.0110 \\ 1110111.1101 \\ \hline \end{array} = 119.8125$$

(ii) $1001011.011 - 111.111$

$$\begin{array}{r} 1001011.011 \\ - 111.111 \\ \hline 1000011.100 \end{array} = 67.5$$

4. (a) Distinguish between machine and assembly language (2mks)

- Machine language or 1st generation language- data and instruction are represented as binary digits; is machine dependent.
- Assembly Language or 2nd generation language or low level language – data & instruction are represented using English like symbolic abbreviations to represent machine language instructions; machine dependent.

(b) State the type of translator necessary for a program written in:

- (i) High level language
- Compiler
 - Interpreter
- (ii) Assemble language
- Assembler

5. Briefly explain the purpose of the following types of program documentation

(a) User manual

- Manuals provided for an end user to enable him/ her learn how to use the software.

Provides examples to take the user through the stages of various tasks

(b) Reference guide

- Provides detailed information to a user who already knows how to use the software but wants to know a particular point or more information about a particular feature in detail.

(c) Quick reference guide

- A single sheet or card, small enough to fit a pocket, which the user may keep handy for help with common tasks carried out with the software.

6. State any two features of a user- friendly program

- Relatively easy for user to start using the software

- Amount of effort & information required of the user to get the system to complete required tasks should be kept minimum
- Systems should be self-contained so that the user is not forced into accessing manuals or dealing with things be kept out of the system
- System should be able to adjust to different levels of expertise between users, and as users grows in competence.
- User should be made to feel in control of what is going on

7. (a) Distinguish between labels and formulae with respect to spreadsheet (2mks)

Label- a non- numeric piece of data entered into an electronic spreadsheet cell. Labels are not used for computations. Any cell entry, which begins with a letter or on apostrophe, is a label.
Formulae- Mathematical computations which join other cells' values with mathematical operators such as +, -, * or /

(b) Consider the entries in the cells below

Cell	B2	B3	C10	C11	C13
Entry	200	100	B2	B3	C10 + C11

State the values displayed in cell C14 (2mks)

Error (#value) NB: the = sign is missing in cells C10 and C11

8. List three differences between Wide Area Networks (WAN) and Local Area Networks (LAN) (3mks)

<p>LAN</p> <ol style="list-style-type: none"> 1. Private communication network connected by a length of cable that serves a company located within a radius of 10 m – 3 km 2. Modems are not always needed 3. Telephone circuit not required 4. High data transmission rates 5. Low cost transmission 	<p>WAN</p> <ol style="list-style-type: none"> 1. Connects LANs, MANs and covers a much wider geographical area more than 3 km. 2. Modem, routers and other communications h/w are required to complete the WAN 3. Telephone circuit required 4. Low data transmission rates 5. High transmission link cost
---	--

9. Study the flowchart segment below and state the last value printed from the flowchart. (2mks)

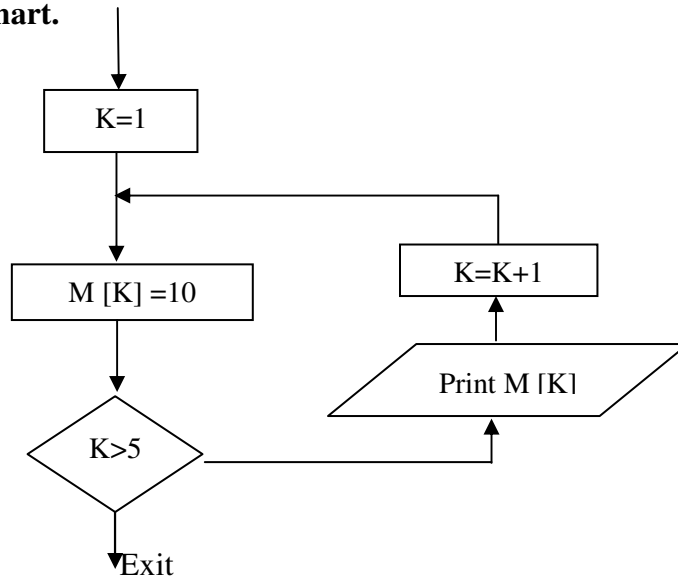

10. (a) What is an expert system (1mk)

- A software consisting of knowledge and rules for using it gathered from human experts in a particular occupation e.g. medicine. An expert system has the capability to store the collection of knowledge & manipulate it in response to user inquiries

(b) State any two components of an expert system (2mks)

1. Natural language interface
2. A knowledge database (Where facts are stored)
3. An inference machine (software that solves problems and makes logical interference)
4. An explanation module (which explain its conclusion to the users)

11. Give two reasons why optical disks are better storage media compared to floppy diskettes (2mks)

1. Enormous storage capacity compared to floppy diskettes
2. Faster access time and data transfer rates as compared to floppy diskettes
3. Data Recorded on optical disks is not damaged by stray magnetic fields and surface problems like fingerprints, dusts etc.

12. What are the DOS commands used for the following?

- (a) Changing directories – CD\
- (b) Viewing directories – DIR
- (c) Renaming directories – REN or RENAME
- (d) Deleting a directory- RD\

13. Distinguish between copying and moving text

Copy- This function makes a copy of the selected text and places the copy in a new location leaving the original text in its original location

The cut function- (move) physically removes selected text from its original location & places it in a new location.

14. (a) Name two methods of paper orientation

(1mk)

- Portrait
- Landscape

(b) Name two keys used to delete text in a document

(1mk)

- Del
- Backspace

15. Name two features of database package

- (i) Create, insert, update and delete facility
- (ii) Query facility
- (iii) Sorting facility
- (iv) Authorization facility
- (v) Recovery control feature/ system
- (vi) View mechanism

SECTION B (60 MARKS)

16. Study the flowchart below and answer the questions that follow

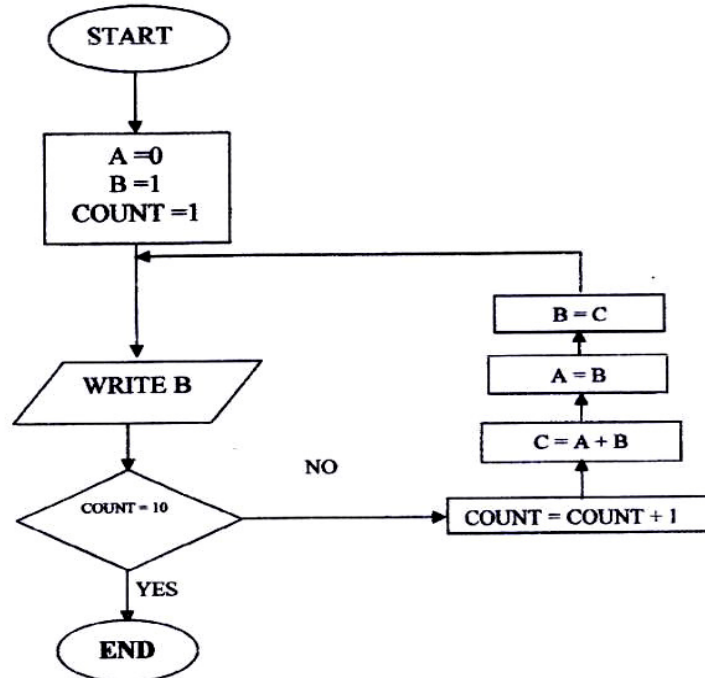

(a) Write a high level language program for the above flowchart (7mks)

```

Program Displays (input, Output);
Var
A,B,C count: Integer;
Begin

A:=0;
B:=1
Count =1
While Count <10 do
Begin
Count:= Count + 1;
C: = A + B;
B:=C;
Writeln (B);
End;
  
```

or

```

Program displays (input, Output);
Var
A,B,C, count: Integer;
Begin
A: = 0
B:-1
Count: 1
For count: =1 to 10 -1 do
Begin
C: A + B;
A: =B;
B:=C;
Writeln (B);
End;
End.
  
```

**(b) List the outputs of the flowchart above
1,2,3,5,8,13,21,34,55**

(c) Modify the flowchart so that it adds up all its outputs and displays the sum obtained (3mks)

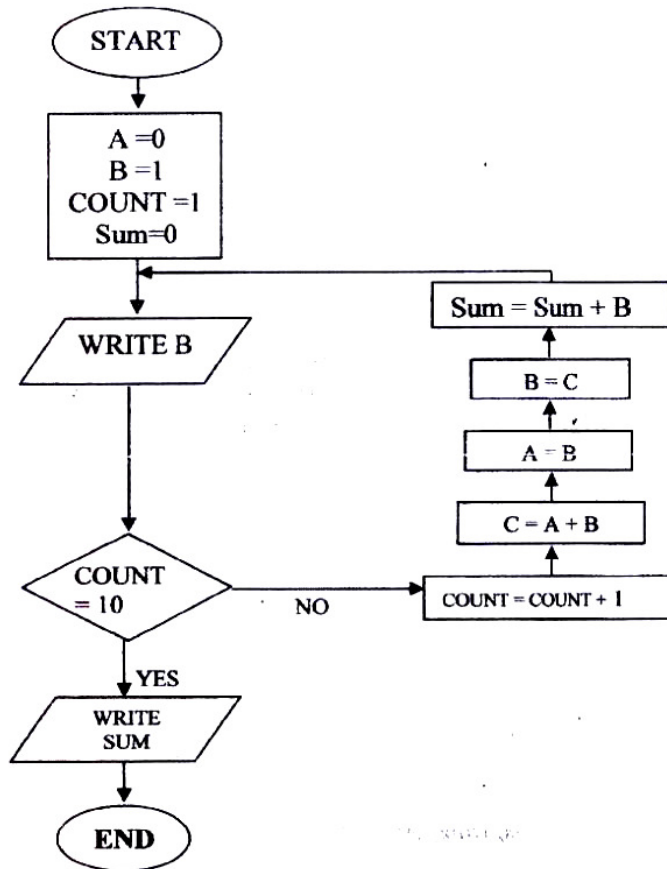

17. A computer specification has the following details

A computer specification has the following details:

- Pentium II
- 1.44 MB floppy disk drive
- 20 GB hard disk
- Full multimedia
- 17" SVGA monitor
- Pre installed operating system
- Pre- installed office suite

(i) What is meant by:

The system units contain a floppy disk drive that can read/ write diskettes of capacity 1.44 megabytes.

(ii) 20 GB hard disk

The hard disk storage capacity is 20 gigabytes

(iii) 17” SVGA monitors

Diagonal length (size) of the monitor is 17 inches and the motherboard has a super VGA graphics adapter. SVGA has a resolution of 800 x 600 pixels

(b) Which operating system might be pre- installed in this computer and why?

Win 95, 98, ME

Reason: supports multimedia, office suite

(c) List three multimedia components

- CD Rom
- Speaker
- Microphones
- Multimedia projectors

(d) (i) What is meant by computer aided manufacture?

- The linking of the software through a computer network to the manufacturing machinery. Robots controlled by the computer accurately perform the assembly or manufacture based on the design produced by CAD (Computer Aided Design)

(ii) Give two examples of computer aided design software

- AUTOCAD
- 3D CAD
- DESIGN CAD
- TOTAL CAD
- TURBO CAD

18. (a) Give three examples of network software

- Server software
- Client software
- Network operating system like Linux, UNIX, Win 2000, and Win NT

(b) List any three items that may be referred to as data terminal equipments in a network (3mks)

- Terminals, computers, protocol converters (NIC), Multiplexor, printer

(c) Briefly explain the following terms as used in networking (4mks)

(i) Remote communication

- Is a way/ method of connecting computers to networks over telephone lines

(ii) Distributed processing

- Data processing where computations and data storage are spread among the computers on a network

(d) State three advantages and two disadvantages of mesh network topology

Advantages

- (i) Fault tolerance. Media faulting has been impact on mesh. Redundant links enable data to be sent over several different paths
- (ii) Guaranteed communication channel capacity
- (iii) To trouble shoot

Disadvantages

- (i) Difficult to install especially as the number of devices increase since numerous connections must be made.
- (ii) Cost. Difficult to maintain redundant links

19. (a) A company has decided to computerize their operations. They have decided to purchase packages instead of developing their own programs. Give three advantages and two disadvantages of this approach.

Advantages

- (i) Saves on programming effort and exposure on the part of the user (client)
- (ii) The user gets a well- tried and tested program
- (iii) Relatively quick implementation results from use of package

Disadvantages

- (i) Purchaser does not have full control over the packages as would have been if it was developed in house
- (ii) Package is produced to meet general needs & may not be ideal for a particular customer

(b) (i) Explain why a value such as 6112334445555 may be displayed as ##### when typed in a cell on a spreadsheet (2mks)

- The value is too large to be displayed in the current cell width

(ii) How can the problem in (b) (i) above be corrected?

- Expand the cell/column width

(c) With reasons, briefly describe the most appropriate type of printer or output device for the output of: (6 mks)

(i) Customer invoices on multi- part stationery

- Dot- matrix printer – can print multiple copies

(ii) Letters to customers

- Laser – fast and economical on ink usage

(iii) Detailed engineering designs

- Plotter- captures and prints detailed layouts of drawings

20. Distinguish between the following pairs of terms

(i) Data verification and data validation

Data Validation – Consistency and integrity of data e.g. if input field is numeric then it must only receive numerals. Anything else is considered invalid

Data verification- Ensuring that data entered is the same as in the source documents

(ii) Data Encryption and passwords

Encryption - Encoding a message using a secret key called a cipher. For one to be able to read the message, they must understand how to decrypt it using the cipher.

Password – A secret combination of characters (numbers/ letters), used to prove the identity of a person attempting to gain access to a computer system. Normally supplied with a username, Should be kept secret.

(iii) Dry run and walk through

Dry run- testing done on a program by simulating its execution by a manual pencil and paper exercise

Walk through – testing done by inviting other experts to review a program, system or project.

(b) Draw a labeled diagram to illustrate the internal structure of a diskette (4mks)

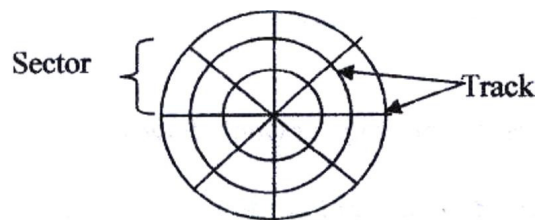

(c) Give two differences between post office mail and electronic mail (E- Mail) (2mks)

Post office Mail

- Expensive compared to email since stationery, stamps and transport costs incurred
- Slow to reach recipient
- Not easy to forward message to dispersed users

Email

- Costs less to send
- Message sent to users across a computer network
- Message can contain attachment files (WP, Spreadsheets, Graphics etc)
- Recipient can forward message to other user quickly and efficiently
- Recipient can retrieve information from any location across the computer network

(d) Speed and accuracy are some of the advantages of using computers in banking. State three other advantages of use of computers in banking. (3mks)

- (i) Massive storage capacity
- (ii) Electronic funds transfer
- (iii) Processing of cheques using MICR technology
- (iv) Provision of ATM services

COMPUTER STUDIES

Paper 1

(THEORY)

OCT/NOV 2004

2 ½ HOURS

SECTION A

1. **How is a point of sale terminal used in a business organization?(2mks)**
 - Customer's item code quantity and price are entered into a post terminal, POS.
 - The modem EPOS terminals automatically debit the customers account
 - The POS also does stock control, number of goods in stock can be automatically known for the sales

2. **Distinguish between a compiler and an interpreter (2mks)**
 - A compiler translates a whole program from source code to object code while an interpreter translates each command at a time before moving to the next line.

3. **Explain why computers use binary numbers in data representation (2mks)**
 - The computer system is made up of logic that works only with two states "ON" and "Off" for computers to process information, the information itself must therefore be represented in two states- hence of binary numbers (0 and 1).

4. **What is meant by the term 'dry running' as used in program development?**
 - Testing done by stimulating the execution of a program by a manual pencil and paper exercise called a "dry run"

5. **A computer teacher put a rule that diskettes should not be used in the computer laboratory**
 - (a) Give a reason for the rule
 - Introduction of viruses and other bugs from the diskettes
 - (b) State two other alternatives that can be used to achieve the same objective
 - By disabling the diskette drive
 - Having up to date antivirus software that will detect and eradicate any virus in the diskette.

6. **List 3 differences between laser printer and a dot matrix printer**

Laser

 - (a) High print speed
 - (b) Can do no multiple jobs
 - (c) Quiet printing
 - (d) Uses photocopier technology
 - (e) High print quality

Dot matrix

 - (a) Low printing speed

- (b) Can do multiple printing
- (c) Noisy printing
- (d) Characters formed by combination of dots
- (e) Low print quality

7. List four stages involved in the data processing cycle (3 mks)

- Origination of data
- Preparation of data
- Inputting of data
- processing
- Output
- Storage

8. (a) What is utility software

- Are system programs that provide a useful service to the user of the computer by providing facilities for performing tasks of a routine nature

(b) Give four examples of utility software

- Sort
- Editors
- File copying
- File maintenance
- Disk managers
- CHKDSK
- DEFRAG
- SCANDISK

9. Distinguish between an intelligent terminal and a dumb terminal

Dumb terminal – A computer or communications terminal that has no processing capabilities (has a keyboard and a monitor).

Intelligent terminal- A computer terminal that has its own processor

10. List duties of each of the following personnel

(a) Database administrator

- Responsible for the physical realization of database system including:
- Physical database design and implementation
- Security and integrity control
- Maintenance of operational system
- Ensuring satisfactory performance for the application and users

(b) Data processing manager

- Sourcing for appropriate data
- Sorting data for various input processes
- Verify that data input is correct
- Ensure data is complete before processing e.g. batch processing

- Dispatch outputs to relevant outlets.
-

11. Differentiate between source program and object program

- Source code Instructions that a programmer creates when writing a program/ instructions in the high level language.
- Object Code- Machine language code that is output by a compiler or assembler

A translator converts source code to object code

12. (a) In DOS, what are the following commands used for?

- (i) RD-Removes a directory
- (ii) DEL *- deletes all files

(b) What happens when the following commands are typed in DOS environment

- (iii) CD – takes the user one step backwards in a directory path
- (iv) DIR – Displays files and folders

13. A student presented a budget in the form of a worksheet as follows

	A	B	C
1.	Item	Amount	
2.	Fare	200	
3.	Stationary	50	
4.	Bread	300	
5.	Miscellaneous	150	
6.	Total	200	

The student intends to have spent half the amount by midterm

- (a) **Given that the value 0.5 is typed in cell B9, write the shortest formula that would be typed in cell C2 and then copied down the column to obtain half the values in column B.**

$$= \$B49 * B2$$

- (b) **Write two different formulae that can be typed to obtain the total in cell B6 and then copied to cell C6**

$$= \text{sum} (B2: B5)$$

$$= B2 + B3 + B4 + B5$$

14. State three operations that can be performed on relational database files

- Sorting
- Querying
- Report creation
- Performing calculations
- Indexing

15. List three parts that constitute an array definition statement

- Array name
- Boundary

- Data type
e.g.
Array = MyArray { 1...n } of
Integer;

16. **Bidii wholesalers have two categories of customers for order processing.** Category 'A' obtains 10% discount on all orders upto Kshs 10,000 otherwise the discount is 20% on the entire order. Category 'B' obtains 30% discount on all orders if the debt repayments is 'good' otherwise the discount is 15%. Draw a flowchart for the order processing.

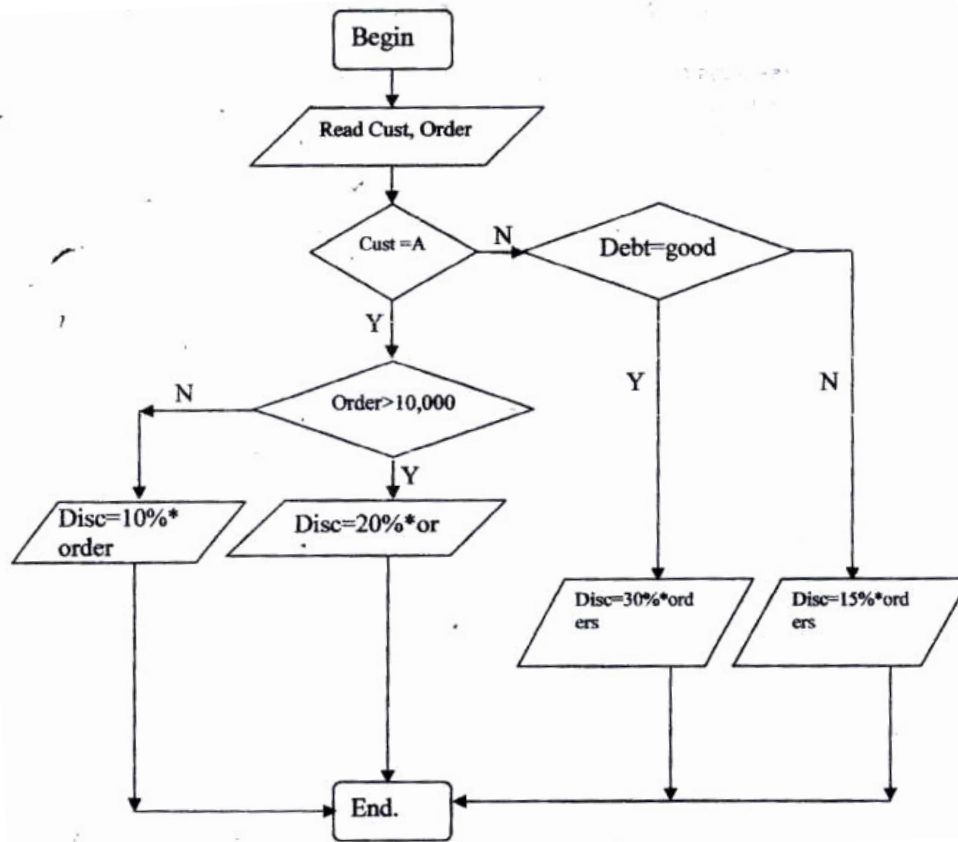

17. (a) **List three application areas of artificial intelligence**
- Robotics
 - Natural language processing
 - Expert systems
- (b) **With the improvement in the price and performance of computers and communication equipment, it will be possible for people in various business organizations to work from home. Such working using a PC as a remote terminal is often described as tele-networking. State three advantages and three disadvantages of working from home**

Advantaged

- Impending quality life
- No stress of traveling to the office
- Traveling time saved
- Cost of traveling saved
- Greater flexibility when working at home

Disadvantages

- Possible feeling of isolation
- No social contact with fellow workers
- Additional cost of home working equipment and connection charges or employees
- More difficult to build firms and share ideas between colleagues

18. (a) Explain three ways by which computer users can protect their eyes from harmful emissions from the computer screen

- Using a glare filter
- using an LCD screen (does not emit radiation)
- Not sitting in front of the computer for long hours

(b) List three factors be considered when deciding on the choice of an electronic data processing method

1. Suitability of accumulating data (Transmission) into batches for processing
2. Need for direct information retrieval and / or file interrogations
3. Optimization of the processing time
4. Time factor of the information for decision making by the managers
5. Cost of acquiring the necessary h/w, s/w media etc

(c) Explain time-sharing data processing mode giving two advantages and two disadvantages of its application.

- Central processor serves two or more users with different processing requirements (tasks) Central processor is available to a variety of users connected to the central compare via communication links. Processors time is divided appropriately among users' tasks into time slices. Control switched from one job to another under the influence of the OS, in turn, the processors idle time is removed.

Advantages

- Information output is fast
- Processor idle time is removed
- File enquiry is fast since file are held online

Disadvantages

- Users have no control over central computer
- Response time is more when there are many users

19. A school has brought a computer system. The hardware items include: 800 MHz processor, 640 MB of RAM, a sound card, speakers, a monitor, a keyboard, a 12 GB hard disk, a floppy disk drive, CDRW drive, a mouse, a modem, an inkjet printer and a joystick. The software supplied includes: an OS, a BASIC interpreter and the following packages: Spreadsheets, graphic, word processor, art database and games.

(a) List three input devices from the given specifications

- Keyboard
- Mouse
- Joystick

(b) Explain the meaning of the following

(i) 800 MHz- refers to the clock speed/ processor speed. The number of clock cycles per second at which the computer performs its basic operations

(ii) 640 MB- The size of the main memory installed inside main memory, which holds data and information waiting to be processed.

(iii) 12 GB- The size of the fixed disk (hard disk) in the computer, it is a secondary storage medium.

(c) Some of the students in the school use the computer to do homework.

Name the packages used to:

- (i) Do calculations and draw graphs- Spreadsheets
- (ii) Write an easy - word processor
- (iii) Make a poster - graphics

(d) Students enjoy playing noisy computer games

- (i) Which hardware items are needed to produce sound?
 - Soundcard, speakers
- (ii) Which input device is used only for playing games?
 - Joystick

20. A school magazine organizes its works in directories. The directory WP contains the files CATS, EXAMS and ASSIGNMENTS. The directory Sp contains the spreadsheet files and the DB directory contains the database files. The directory PROG is contained in the others directory. The directory WP is contained the PERSONAL directory. Given that the directory student contains directories SP, WP, and OTHERS.

(a) Draw the directory tree structure with C as the root

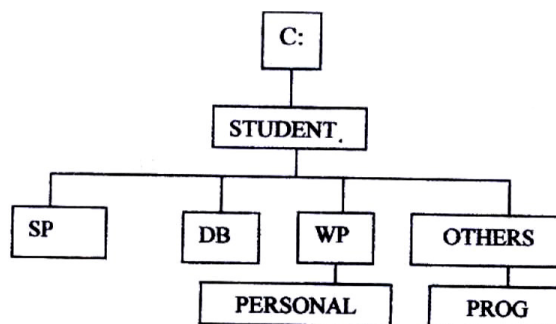

(b) Write the path at which the contents of the subdirectory Db can be erased or displayed

C:\STUDENT\DB

(c) Write the path for the directory PROG

C:\STUDENT\OTHERS\PROG

(d) Give two reasons for storing files in directories and sub- directories

- Better management e.g. files from one application or department can be stored in different directories so as not to mix them. A directory serves as a table of contents and allows convenient access to files

(e) Give two disadvantages of using command driven interfaces as compared to menu driven interfaces

- Need to recall / memorize commands
- Only good to expert users not novices
- Commands are often obscure and vary across systems, causing confusion to the user and increasing overhead of learning.

COMPUTER STUDIES

Paper 1

(THEORY)

Oct. /Nov 2005

2 ½ hours

MARKING SCHEME

SECTION A (40 marks)

1. (a) **What is a disk formatting?** (1mk)
- To prepare storage medium by defining tracks and sectors where data will be placed in compliance with specific operating system requirements.
- (b) **Indicate whether the following devices are used for input or output** (2mks)
- | | | |
|-------|----------------|--------|
| (i) | Plotter - | Output |
| (ii) | Light pen | Input |
| (iii) | Mouse | Input |
| (iv) | Visual display | unit |
2. (a) **Explain why the following controls should be implemented for computer based systems** (2mks)
- (i) Backups – To maintain a copy of original data in case the original one is lost or corrupted.
- (ii) Passwords – To prevent unauthorized users from trying to access private data
- (b) **For each of the following give one reason why they are not allowed in a computer laboratory.**
- (i) Smoking - Can start fire
- Can introduce dust through smoke particles
- (ii) Eating foods- Can spill and spoil computer parts like keyboard
3. **Distinguish between Real, Integer and Character data types as used in programming** (3mks)
- Real - Constant is represented in two parts, a mantissa part and an exponential part e.g. 123.456
- Integer - Constant must have at least one digit written without a decimal Point.
- Character - A data component that represents a single letter or symbol
4. **The cells K3 to K10 of a worksheet contain remarks on student's performance such as very good, good, fair and fail depending on the average**

mark. Write a formula that can be used to count all students who have the remark “very good”

(3mks)

= countif(K3:K10,”very good”)

5. (a) **State the purpose of registers in a computer system** (1mk)
- To hold data and instructions temporarily as they are being processed in the CPU (2mks)

(b) **Name two multiprogramming operating systems** (2mks)

- Windows 9X, Linux, Windows 2000, and Windows NT

6. (a) **A serial file comprises of records placed in positions 1 to 10. State the position of the end of file marker** (1 mk)

11

(b) **State the purpose of each of the following** (2mks)

(i) File server software

- Software that provide file handling and storage functions for multiple uses on a LAN e.g. Windows NT, Windows 2000, Linux

(ii) Communication software

- Program that allows a computer to connect with another computer e.g. telephone directories, facilities that automate dial up process, log on procedures etc

7. (a) **Name the control structure depicted by the flowchart below**

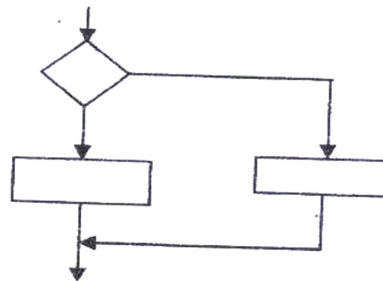

If...then ...Else

(b) **Explain the following terms as used in program implementation** (2mks)

(i) Parallel; running- running in alongside with the information system it is intended to replace

(ii) **Direct change over-** starting full operation instantly in the whole organization (cut – over) & replacing the old system

8. **Consider the linear arrays:**

(iv) AAA (5:50) - 46

(v) BBB (5:10) - 16

(vi) CCC (18) -18

Find the number of elements in each array

(3mks)

- 9. Define the term artificial intelligence (2 mks)**
- Artificial intelligence can be defined as the field of study concerned with using computer hardware and software to simulate human thought processes such as imagination and intuition.
- 10. Name two types of relationships that can be applied in database design (2mks)**
- a. One to one
 - b. One to many
 - c. many to many
- 11. Explain the following terms as used in word processing (3mks)**
- (a) Indenting – reducing the size of a text block to set that section apart from the rest of the text.
 - (b) Alignment – The positioning of text with respect to the right and left margin of page.
This can be to the left, right, centre or justified
 - (c) Word wrap – a feature of a word processing software that ensures that a word that will not fit at the end of a line will automatically be placed at the start of the next (new) line
- 12. Outline two ways in which computer can be used in hotels (2mks)**
- (i) Room reservation system
 - (ii) Financial and human resource management
- 13. (a) explain Binary Coded Decimal code of data representation (1mk)**
- BCD is a 4-bit code used for coding numeric values only. Unlike pure binary each number or digit is assigned a specific binary code to represent it.
- (b) Write the number 451_{10} in BCD notation (1mk)**
-100101001
- 14. Arrange the following data units in ascending order of size (2mks)**
BYTE, FILE, BIT, NIBBLE
BIT, NIBBLE, BYTE, FILE
- 15. State two health issues that may result from prolonged use of computers**
- (i) Exposure to electromagnetic radiation through the VDU
 - (ii) Eye Strain
 - (iii) Repetitive strain injury causing muscle fatigue etc

SECTION B (60 MARKS)

16. (a) State the stage of program development in which:

- (i) A flowchart would be drawn
Design
- (ii) The programmer would check whether the program does as required
Testing
- (iii) The user guide would be written
Documentation
- (iv) The requirements specifications would be written
Analysis

(b) State the output of the following flowchart segment

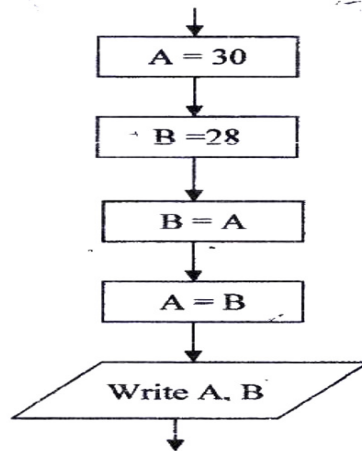

(c) (i) Draw a flowchart to compare the combined resistance (R) of two resistors R₁ and R₂ in parallel using the formula

$$R = \frac{1}{\frac{1}{R_1} + \frac{1}{R_2}}$$

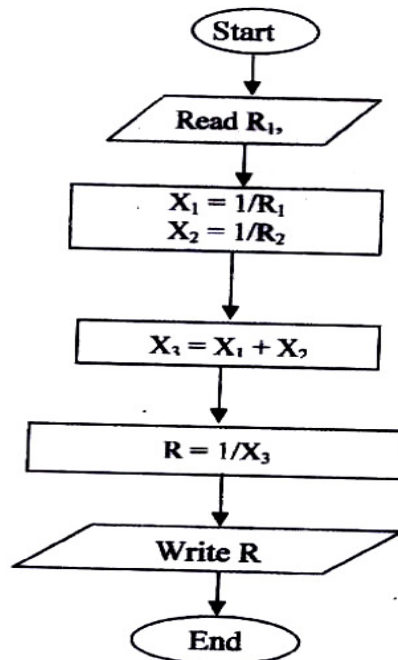

- (i) Write a program using Pascal or C languages for the flowchart in c (i) above. (5½mks)

```
Program Resistance (input, output)
Var
R, R1, R2, X1, X2, X3: Real;
Begin
Writeln (this program computes the combined resistance ® of two resistors in
parallel');
Writeln (please input the values of R1 and R2, press Enter to continue');
Readln (R1, R2);
x1:1/r1;
x2:1/r2;
x3:=x1+ x2;
R: = 1/x3;
Writeln (the value of the combined resistance is R: 3: 2);
Readln;
End
```

17. (a) List three paragraph formatting activities in word processing(3 mks)

- i. alignment
- ii. Tabs
- iii. Indentation
- iv. Outline level
- v. Line spacing

- (b) Differentiate between holding and highlighting text (2 mks)

- Bolding – A style of text that adds emphasis to a character by making it darker and heavier than normal type.
- Highlighting – To select an area of a document in order to apply a command to the area or work with that selection.

- (c) The following information shows the income and expenditure for “Bebayote” matatu for five days. The income from Monday to Friday was Kshs 4,000, 9,000, 10,000, 15,000 and 12,000 respectively while the expenditure for the same period was Kshs, 2,000, 3,000, 7,000, 5,000 and 6,000 respectively.

- (i) Draw a spreadsheet that would contain the information. Indicate the rows as 1, 2, 3.... And the columns as A, B, C. (4 mks)

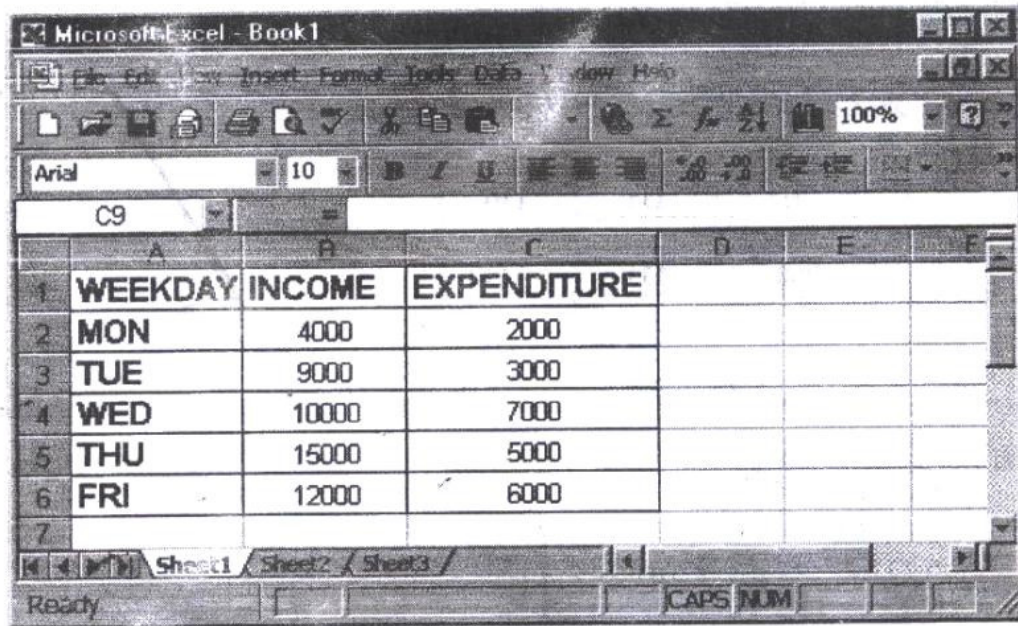

(i) State the expression that would be used to obtain:

- I. Monday's profit = B4 - C4 (2 mks)
- II. Total income = Sum (B2: B6) (2 mks)
- III. Highest expenditure = Max (B2: B6) (2 mks)

18. (a) Subtract 0111_2 from 1001_2 (2 mks)
 0010_2

(b) Using two's compliment, subtract 7 from 4 and give the answer in decimal notation (4mks)

$$7 = 111_2$$

$$4 = 100_2$$

-4 in two's compliment is 100

$$\therefore \begin{array}{r} 111 \\ 100 \\ + 1011 \end{array}$$

The resulting answer is 011 since the overflow is ignored. In decimal notation this is 3_{10}

(c) Convert

(i) $91B_{16}$ to octal

9	1	B
1001	0001	1011

100	100	011	011
4	4	3	3

$$91B_{16} = 4433_8$$

(ii) 376_8 to hexadecimal

3	7	6
011	111	110

0000	1111	1110
0	F	E

$$376_8 = FE_{16}$$

(iii) 9.625_{10} to binary

$$9 = 1001$$

$$0.625 \times 2 = 1.25 \text{ WRITE } 1$$

$$0.25 \times 2 = 0.5 \text{ WRITE } 0$$

$$0.5 \times 2 = 1.0 \text{ WRITE } 1$$

$$9.625_{10} = 1001.101_2$$



19. (a) Explain what the following DOS commands will do when executed

(i) A:\copy ** B

- Copy all files in drive A to drive B

(ii) C:\ERASE * DOC

- Delete all file with the extension DOC from drive C

(iii) B:\DIR P*.BAT

- List all files starting with P and having extension BAT in drive B

(iv) A:\>MD EXAMS

- Create a new folder/directory called EXAM in drive A

(b) (i) With the aid of a diagram, explain hierarchical (tree) network topology

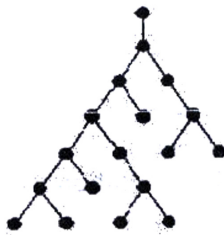

A network topology that, from a purely topologies viewpoint, resembles an interconnection of star networks in that individual peripheral nodes are required to transmit to and receive from one other node only, toward a central node, and are not required to act as repeaters or regenerators.

(ii) List two advantages and two disadvantages of hierarchical network topology. (4mks)

Advantages

1. Easy to expand the network
2. A peripheral node failure may not disrupt the entire network

Disadvantages

- (1) Individual nodes may be isolated from the network by a single-point failure of a transmission path to the node.
- (2) A single point failure of a transmission path within a distributed node will result in partitioning two or more stations from the rest of the network

20. (a) Name and explain the function of the keyboard keys represented by the following symbols (2mks)

(i)

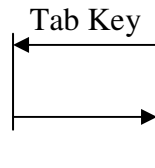

Used to remove text/ cursor to the right by a fixed or present number of spaces

(ii)

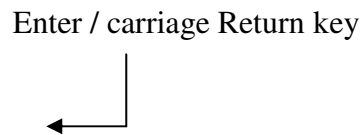

Used to initiate command on the screen i.e. Pressed after each command.

(iii)

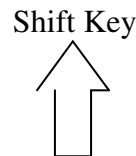

Used to change letter case
Also used in conjunction with other keys for various Commands.

(b) Simulation is one of the application areas of computers

(i) What is meant by the term simulation (1mk)

- A simulation program is designed to predict the likely behaviour of a real life system. The real – life situation is represented as a mathematical model in the computer program.

(ii) Name two application areas of simulation (2mks)

- Training of pilots
- Weather forecasting

(iii) State three advantages of computer based simulation (3mks)

- Simulators are less expensive to operate than actual airplanes
- Pilot training is not affected by weather conditions
- Training in emergency situations can be safely given
- Different conditions such as night flying can be simulated
- Practice can be given in take- off and landing at airports worldwide

(c) Explain three ways in which computers have impacted on Education (3mks)

- Teaching has been made easier through modeling packages. Modeling is when a computer program attempts to represent a real situation. In order to do this, mathematical equations are used. Different values can be input to the model to investigate possible outcomes.
- Simulations packages can be used to train students
- Multimedia packages offer a wealth of resources material, which students can transfer across into their project work
- It is easier to maintain school/ students records using computers

Paper 1
(Theory)
Oct. Nov 2006
2 ½ Hours

MARKING SCHEME

Section a (40 marks)

1. What is meant by:

(a) Analogue data: Data that is based on physical variations such as loudness and pitch, electoral voltages etc

(b) Digital Data- Data, which use the computer's binary number systems 0 and 1

2. Distinguish between transcription and transportation types of errors and give an example of each

- A transcription error is a specific type of data entry error that is commonly made by human operators or by optical character recognition (OCR) programs

E.g. Name: Stamley (wrong) instead of Stanley (Correct)

- A transposition error is an error caused by reversing two or more digits of an amount while posting transactions. These are almost always human in origin
An Example is ZIP code: 57429 (wrong) instead of 54729 (correct)

3. (a) What are peripheral devices? (1mks)

- Any device connected externally to the CPU

(b) Give two examples of peripheral devices (1mk)

- Mouse, Monitor, Keyboard, printer etc

4. (a) What is meant by the term user – friendly as used in software development?

- Software that is easier to use or work with (1mk)

(b) Distinguish between the terms single- tasking and multi- user as used in operating systems (1mks)

Single tasking – the O/S allows one program to be processed at a time

Multi – user an O/S that allows several tasks/ programs to be simultaneously

5. What actions should be taken in case of a fire outbreak in the computer laboratory? (4mks)

- Switch off main electrical supply

- Vacate the room

- Inform master in charge

- Call for help

- Try to extinguish using the appropriate fire extinguisher (not water)

6. (a) What is an internet service provider?

- A company that provides internet services. Connects users to the internet

- (b) An employee in a business company is charged with the responsibility of putting the company advertisement on the internet
- (i) **State the professional title of the employee** (1 mk)
- Web administrator, web designer
- (ii) **Give an example of software used by this employee to carry out the above task** (1 mk)
- HTML, Dream weaver, MS Front Page
7. **Differentiate between COM ports and LTP ports**
- COM port also known as a serial port transmits data bit by bit
- LTP port also known as a parallel port transmits multiple bits simultaneously at a time.
8. **Explain two ways in which ICT can enhance commerce**
- Through better advertisement on the internet
- Through better services in retail shops via point of sale terminals
- Through electronic funds transfer
9. **Explain the following software terms**
- (a) **Portability** (1mk)
- Ability of a software to work/ function in several computer hardware and O/S platforms (
- (b) **Modularity**
- Ability of software to be broken down into several sections for easier understanding and maintenance.
10. (a) **State two applications areas of desktop publishing software. (2mks)**
- Posters
- Book publishing
- Card design
- (b) **Explain the following graphic terms**
- Rotate- to turn an image through an angle (1mk)
- Crop – to trim the edges of an angle (1mk)
11. **Distinguish between margins and borders as used in word processing** (2mks)
A border is a decorative frame that surrounds a page or elements on a page. The border can be a simple rule line or an elaborate set of lines and curves. A border can be composed of repeating graphic elements. Borders can be used to set apart, draw attention or unify disparate elements.

Margin The blank space that surrounds the text on a page or the boundary line or the area immediately inside the boundary or the blank space that surrounds the text on a page.
12. (a) **List two arithmetic operations that can be performed on a row of numeric data in a word processing table**
+,-,x,/

- b) In each case of (a) above, write the expression used (2mks)
 = Function name (left) or = function name (right) e.g. = sum (left) (2mks)
13. List two methods of gathering information during system developments process. (2mks)
- Observations
 - Interviews
 - Automatic data capture
 - Studying reports
14. Name three types of optical disks (3 mks)
- CD- ROM
 - CD- RW
 - CD- R
 - CD – W
15. The diagram below shows a formatted plate surface of a storage disk

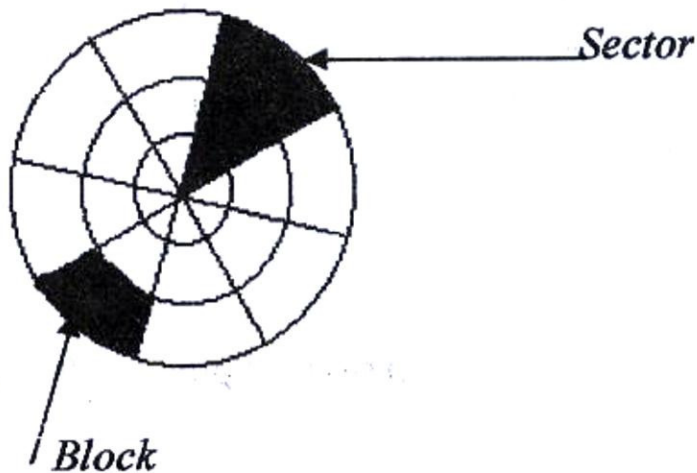

Shade and label:

- (a) One sector (1 mk)
- (b) One block (1 mk)

SECTION B (60 MARKS)

16. (a) **List two examples of:** (2mks)
(i) Third generation languages
Pascal, basic, c
(ii) **Object oriented languages** (2mks)
VB, Small talk, C++
- (b) **Draw a flowchart to compare three non- equal numeric values A,B,C and print the largest of the three** (1mk)

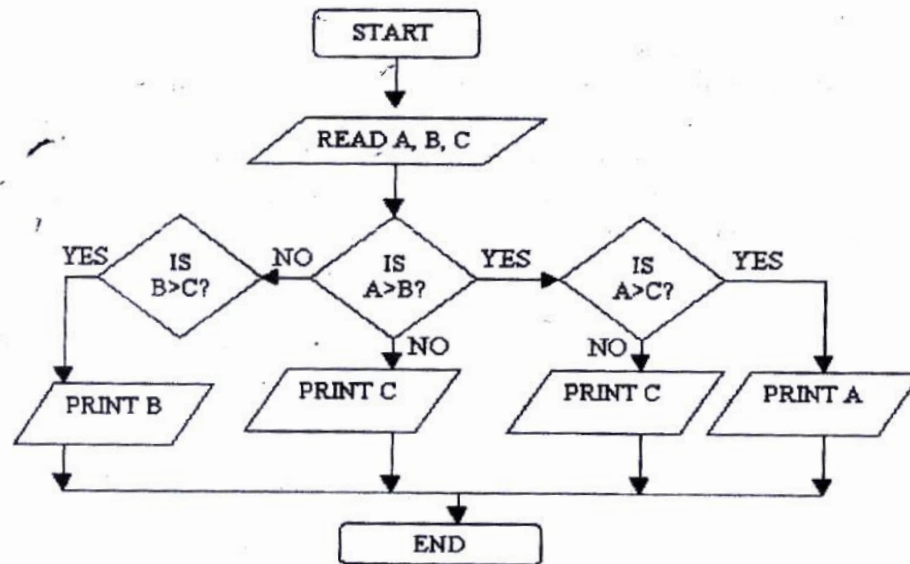

17. (a) **One of the functions of an operating system is job scheduling. Explain what is meant by job- scheduling** (1mks)
- Running of a particular job/ task under a system of priority, computer resource availability, time allocated to user etc.
- (b) List and explain three types of user interfaces
- Command driven- Command language dialogues are those in which the user types instructions to the computer in a formally defined language
- Menu driven- These allow the user to issue commands by selecting choices from a menu of displayed alternatives
- Graphical User interface- These are those in which the user manipulates, though button pushes and movements of pointing devise such as a house, a graphic or iconic representation of the underlying data.
- (c) **Describe the following categories of software**
(i) **Firmware**
- Soft ware that is burnt in computer ROM chips, usually system software
(ii) **Proprietary Software**

- Any software as opposed to freeware, which is available freely
- (d) **A new company XYZ intends to go into the business of desktop publishing. Advise the company on three computer hardware system specification features to consider as a measure of enhancing performance. (1mks)**
- Consider RAM capacity
- Consider speed of computer
- Consider hard disk capacity

18. (a) **Distinguish between the following sets of terms as used in spreadsheets**

(i) **Worksheet and workbook**

Worksheet – The working area in an electronic spreadsheet on which a user enters the spreadsheet data.

Workbook – A spreadsheet file. A workbook can contain several worksheets

(ii) **Filtering and sorting**

Data filtering is a way of organizing spreadsheet data for ease of analysis. Often spreadsheet filters are used to “hide” rows of data that do not meet certain specified criteria. This allows you to analyze (e.g. count, observe etc) only certain “Filtering” groups of data.

Data sorting: Is a way of arranging record according to one of the fields in either ascending or descending order.

(b) **State one way in which a user may reverse the last action taken in a spreadsheet package (1 mks)**

- Use the undo command (ctrl + z)

(c) **The following is a sample of a payroll. The worksheet row and column headings are marked 1, 2, 3, and A, B, C respectively**

	A	B	C	D	E	F	G	H
1	NAME	HOURS WORKED	PAY PER HOUR	BASIC PAY	ALLOWANCES	GROSS PAY	TAX DEDUCTIONS	NET PAY
2	KORIR	12	1500					
3	ATIENO	28	650					
4	MUTISO	26	450					
5	ASHA	30	900					
6	MAINA	18	350					
7	WANJIK U'	22.5	500					
8	WANYA MA	24.5	250					
9	OLESAN E	17	180					
10	MOSETI	33	700					
	TOTALS							

Use the following expressions to answer the questions that follow

- Basic pay- Hours worked x pay per hour
- Allowances are allowed at 10% of basic pay
- Gross pay- Basic pay + allowances
- Tax deductions are calculated at 20% of gross pay
- Net pay= gross pay – tax deductions

Write formulae using cell references for the following cells

- (i) $D2 = B2 * C2$
- (ii) $E4 = 10\% * D4$ or $10\% * (B4 * C4)$
- (iii) $F10 = D10 + E10$
- (iv) $G7 = 20\% * F7$
- (v) $H5 = H5 - G5$

(d) (i) State three ways of moving round the page in desktop publishing window (3 mks)

- Use cursor keys
- use mouse scroller
- Use scroll buttons (horizontal and vertical)

(ii) State two ways on how information & communication technology (ICT) can be used to reduce the spread of HIV/ AIDS (2 mks)

- Through advertisements on the Internet
- Through creation of posters
- Through discussion groups on the internet

19. (a) Describe the following terms with reference to security of data:

(i) **Log files**

- A file that lists actions that have occurred. For example, web servers maintain log files listings every request made to the server. With log file analysis tools, its possible to get a good idea of where visitors are coming from, how often they return and how they navigate through a site.

ii) **Firewalls.** (1mark)

- A **firewall** is an information technology (IT) security device which is configured to permit, deny or proxy data connections set and configured by the organization's security policy. Firewalls can either be hardware and/or software based.

A firewall's basic task is to control traffic between compeer networks with different zones of trust. Typical examples are the Internet which is a zone with no trust and an internal network which is (and should be) a zone with high trust The ultimate goal is to provide controlled interfaces between zones of differing trust levels through the enforcement of a security policy and connectivity model based on the least privilege principle and separation of duties

- b) A students' database comprises of students¹ details table and fees received table as shown below:

Students' details table

Surname
Middle Name
First Name
Admission Number
Course

Fees Received table

Date
Amount
Receipt Number

(i) **State the primary key field for each table.**

Student table- Admission Number

Fees Received table - Receipt Number

ii) **State the field, which should serve as the linking field for the two tables.**

Admission number

(Note: Make Admission Number a foreign key in the fees table)

c) Describe the following terms with respect to computer security:

i) **Logic bombs** (2 Marks)

- *A computer virus that is activated after a series of event/commands/date*

ii) **Physical security** (2 Marks)

Threats that threaten the physical nature of computer equipment e.g. Fire, Lightning water, building access etc

iii) **Tapping.** (2 Marks)

Telephone tapping (or wire tapping/wiretapping) is the monitoring of telephone and Internet conversations by a third party, often by covert means. The telephone tap or wire tap received its name because historically, the monitoring connection was applied to the wires of the telephone line of the person who was being monitored and drew off or tapped a small amount of the electrical signal carrying the conversation

(d) **List three functions of antivirus software.**

- *Identify a virus/Warn*
- *Heal/Clean a virus*
- *Prevent/Protect infection*
- *Quarantine infected files*

20 (a) **The diagram below shows four common network topologies A, B, C and D.**

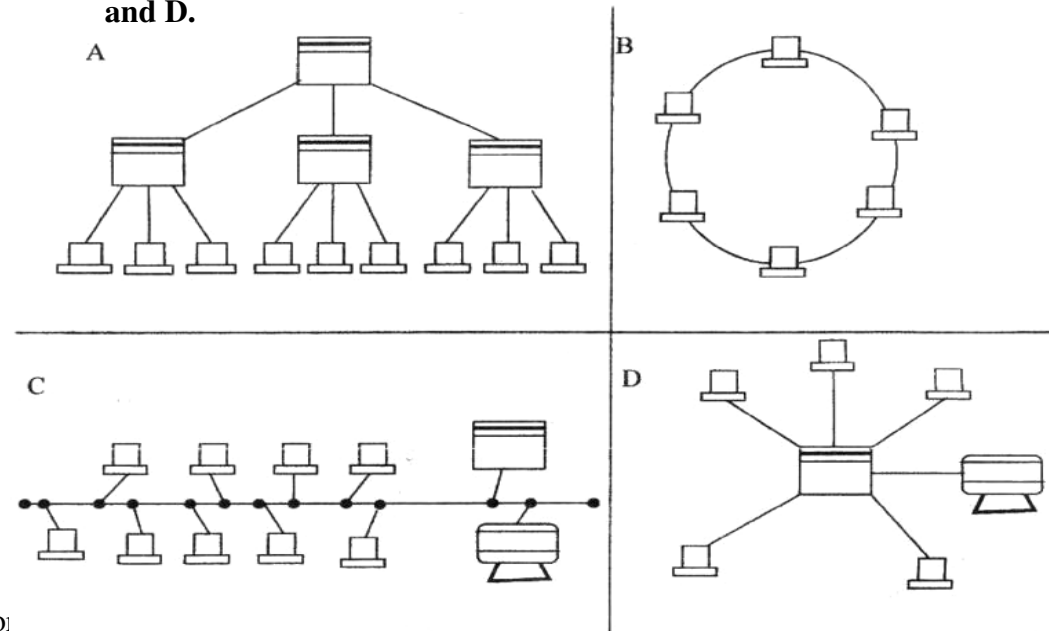

For mo:



Server



Terminal



Printer

- i) **Name the network topologies labeled A, B, C and** (4 marks)
 A *Tree/Hierarchy*
 B *Ring*
 C *Bus/Multi drop*
 D *Star*
- ii) **Explain what happens if server X in topology A fails. (1 Mark)**
 - *The terminal connected to X will be affected/stop communicating with the rest of the network*
- iii) **List two problems associated with network topology B. (2 Marks)**
 - *Difficult to trouble shoot "- Failure of one terminal results in network breakdown*
 - *Extra cost of extra NIC card.*
- iv) **List two disadvantages associated with network topology D. (2 Marks)**
 - *Failure of central device/server results in total collapse of network*
 - *Extra cost of cabling as each terminal must be cabled separately to the hub.*
- b) **Differentiate between Internet and World Wide Web. (2 Marks)**
The Internet *is a massive network of networks, a networking infrastructure. It connects millions of computers together globally, forming a network in which any computer can communicate with any other computer as long as they are both connected to the Internet. Information that travels over the Internet does so via a variety of languages known as protocols.*
The World Wide Web, or simply Web, *is a way of accessing information over the medium of the Internet. It is an information-sharing model that is built on top of the Internet. The Web uses the HTTP protocol, only one of the languages spoken over the Internet, to transmit data. Web services, which use HTTP to allow applications to communicate in order to exchange business logic, use the Web to share information. The Web also utilizes browsers, such as Internet Explorer or Netscape, to access Web documents called Web pages that are linked to each other via hyperlinks. Web documents also contain graphics, sounds, text and video.*
- c) **Describe the following network services and identify their applications. (2 Marks)**
- i) **Voice mail (2 Marks)**
Voicemail (or voice mail, voicemail or VMS, sometimes called message bank) *is a centralized system of managing telephone messages for a large group of people. In its simplest form it mimics the functions of an answering machine, uses a standard telephone handset for the user interface, and uses a centralized, computerized system rather than equipment at the individual telephone.*
Voicemail systems are much more sophisticated than answering machines in that they can:
 - *Answer many phones at the same time*
 - ***Store incoming voice messages in personalized mailboxes associated with the user's phone number***

- Enable users to forward received messages to another voice mailbox
- send messages to one or more other user voice mailboxes
- Add a voice introduction to a forwarded message
- Store voice messages for future delivery
- Make calls to a telephone or paging service to notify the user a message has arrived in his/her mailbox
- Transfer callers to another phone number for personal assistance
- Play different message greetings to different callers.

ii) **Video conferencing.**

(2 Marks)

*A **videoconference** (also known as a video teleconference) is a set of interactive telecommunication technologies which allow two or more locations to interact via two-way video and audio transmissions simultaneously. It has also been called **visual collaboration** and is a type of groupware.*

COMPUTER STUDIES

PAPER 1

(THEORY)

OCT./NOV. 2007

2 ½ HOURS

SECTION A (40 MARKS)

1. Describe the computer booting process (2mks)
 - The internal power supply turns on and initializes.
 - The BIOS performs the power-on self test (POST). If there are any fatal errors, the boot process stops
 - The BIOS looks for other devices' ROMS to see if any of them have BIOSes. Normally, the IDE/Ata hard disk BIOSs will be found and executed. If any other device BIOSes are found, they are executed as well
 - The BIOS begins the search for a drive to boot from
 - Having identified its target boot drive, the BIOS looks for boot information to start the operating system boot process

2. State the functions of the following keys on the computer keyboard (2 mks)
 - c) Backspace – to delete a character to the left of the cursor

 - d) Insert (ins) – when the key is depressed editing is in overtype mode. Any new text typed in the middle of a line is inserted between existing text while the existing text disappears/is deleted.

3. Jane has noticed the following problems in her computer:
 - It is taking longer time to start up;
 - It is often hanging
 - Applications are taking longer to load.State three possible causes of these problems and how they can be solved (3mks)
 - a) **Disk is fragmented** - Defragment the disk by running the defragment utility. "
 - b) **Virus/bug infection** - run the antivirus utility
 - c) **Capacity of RAM is small**- Increase the size by replacing the existing chip with a higher capacity RAM chip.
 - d) **Processor speed is low** - Replace processor with a high speed processor.

4. a) Define authenticity as used in software selection (1 mark)
 - This refers to the genuineness/originality/licensed software. Software that is not pirated.
 - b) List **four** ways of acquiring software in an organization (2 marks)
 - a) **Buy Off-the-shelf package** - This can be sold through retail outlets without any direct contact between the software developer and the customer.
 - b) **Customized software applications** - The software developer builds an application that meets the needs of the customer as defined in a specification.
 - c) Lease or Rent software.
 - d) **Freeware/Shareware**

-also handle important data-conversion function..
- supplies the basic addressing **system** that can be used to get data from one computer to another on the network

- b) Network protocol** (1 mark)
A common set of rules (usually defined by the International Standards body the IEEE) and signals (usually electrical, but may be laser light, infra red radio waves.) that computers connected to a network use in order to communicate on that network medium.
- c) Hub** (1 mark)
The hub or concentrator manages and controls all functions of the network. It also acts as a repeater for the dataflow.
12. List **four** types of publications that can be designed by using desktop publishing software. (2 marks)
- Posters
 - Banners
 - Newsletters
 - Cards
 - Magazines
13. Differentiate between the following pair of terms as used in database design:
- a) Input mask and design** (2 marks)
An input mask often refers to a string expression that a developer defines which governs what is allowed to be entered into a typical edit/input box.
- b) Table and query** (2 marks)
Table - the basic unit of storing data in database
Query - a view created from table(s) that returns specific records based on a criterion.
14. List four factors to be considered when purchasing an operating system. (2 marks)
- a) Does the operating system guarantee the security of your computer, the application software and the data you are handling?
 - b) The second crucial question, related with the issue of security, is the question of the type of network you work with. Is your computer a home computer for simple application such as word application or a corporate or business computer in which you handle high-tech data, confidential information and financial transactions which require high level security?
 - c) A third question you should answer when going for an operating system is the **memory of your computer**. Most current operating systems do not load onto less than 128MB of memory and therefore, for a computer with less memory, old school operating system such as DOS and windows 98 might suffice.
 - d) The cost
Expandability/upgradeability
15. Write an algorithm to compute the area of triangle. (2marks)
(Assume a right angled)
Read the length and height of triangle.
Calculate Area as $0.5 * \text{length} * \text{height}$.
Output Area.

SECTION B (60 MARKS)

Answer question 16 and any other **THREE** questions from this section in the spaces provide*

16. Study the flowchart below and answer the questions that follow

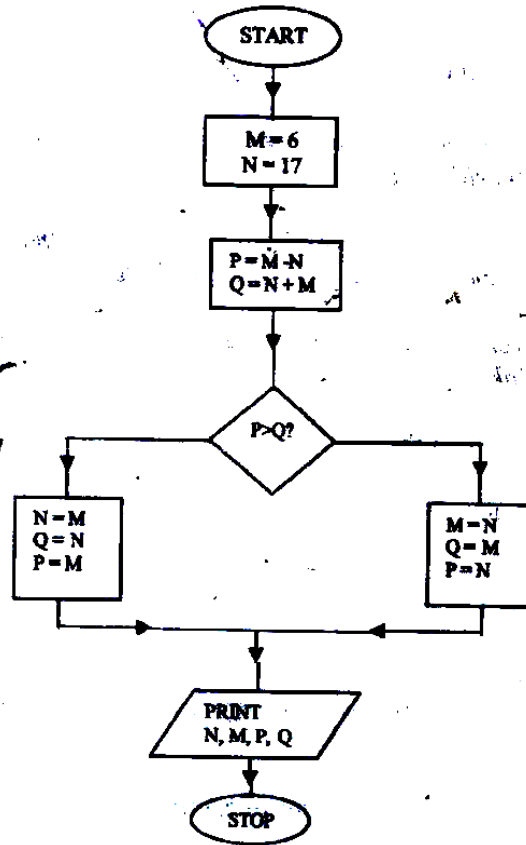

- i) Name the control structures used in the flowchart.
- Selection
- Sequencing
- ii) Determine the values of M, N, P and Q.
M.....17.....N.....17.....
P.....17.....Q.....17.....
- iii) Write the pseudo code for the flowchart

```

START
Initialize M=6, N=17
P=M-N
Q=N+M
IF P>Q THEN DO
    N=M
    Q=N
    P=M
ELSE
    M=N
    Q=M
    P=N
PRINT N, M, P, Q
STOP
    
```

- b) List **four** functions of an assembler. (2 marks)
- a) Translate assembly language to machine code.
- b) Execute assembly language statements.
- c) Create executable files (.exe) from the assembly language statements.
- d) Allocate memory for machine code.
- e) Debug for errors
17. a) **Define the following web related terms:**
- i) **Web browser** (1 mark)
A browser is an application program that provides a way to look at and interact with all the information on the World Wide Web.
- ii) **Hyperlink** (1 mark)
This is the clickable link in text or graphics on a Web page that takes you to another place on the same page, another page, or whole other site.
- iii) **Hypertext document** (1 mark)
A document usually web document (file) where the user interacts with the whole document using hyperlinks
- b) **List six activities performed on the web** (3 marks)
- Browsing for information
 - Communication via email and chat groups
 - Electronic commerce.
 - Advertising of goods and services.
 - Transfer of information thro' FTP
- c) An institution has ten stand alone computers.
- i) **Suggest with reasons the most appropriate topology required to inter-connect the computers.** (3 marks)
- a) Bus
Reason: Easy to set up, Low cost in terms of cabling QR
- b) Star
Reason:
Speed of data transmission is high, Easy to troubleshoot via central hub or switch
- ii) State the necessary steps required to connect the computers to the Internet. (4 marks)
- Connect server to modem (router) and telephone/or use satellite dish/or radio
 - Get an ISP to configure the Internet protocol
 - Configure the rest of the computers to Internet access through a peer-to-peer configuration or a client-server configuration.
- d) **Below is an email address:**
ggitau @moest. edu.ke
Name the parts labeled:
- i) The local-part of the address/username
- ii) host name domain-part
- iii) generic (organizational) top level domain
- iv) country code top level domain

18. A computer C directory has folders for Form 1, Form 2, Form 3 and Form 4. Each class has student's folders labeled according to their number. The students create their own folder for the are studying based on the table shown below.

a) Assuming there is one student per class, draw the corresponding directory

Form 1	Form2	Form 3	Form 4
OS	SP	Prog.	ADB
WP	DTP DB	Internet	

a) Assuming there is one student per class, draw the corresponding directory tree structure.

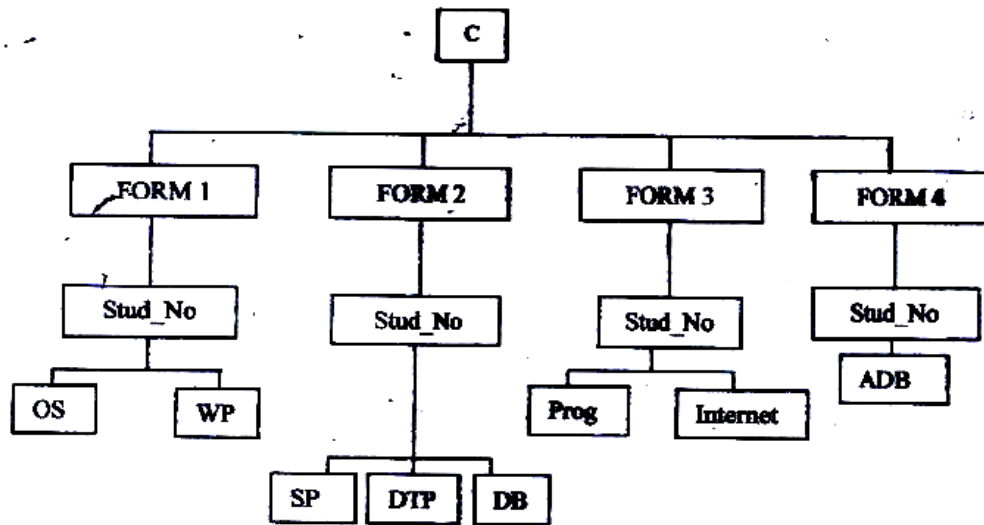

- c) i) A form four student wants to create a folder to store to project State the path for flat project folder. (2 marks)
C:\FORM4STUDNO\ADB\PROJECT
- ii) Suggest how the student can ensure that: - work is not lost in case the hard disk fails. (1 mark)
- Keep backup copies of the project on offline secondary storage media.
 - The project is not copied by other students. (1 mark)
 - Use passwords for opening and modifying the project
- d) Other than I/O devices, list other three devices under the control of the operating
- Main memory
 - CPU/Processor
 - Secondary storage
 - Communication device
- ii) Explain any one of the devices named in c(i) above. (1mrk)
- e) Define the term trouble shooting
Systematic approach to locating the cause of a fault in an electronic circuit or system

19. A manager wishes to replace the current manual system with a computerized one
- a) Describe **three** main areas that must be evaluated to justify the replacement. (6 marks)
 - Technical feasibility: Does the current technology (hardware & software) allow.
 - Economic feasibility: Are funds available?
 - Social feasibility: How will the new system impact on the organization/society?
 - b) List the **three** areas that would be considered in the requirements specifications. (3 marks)
 - Users specifications
 - Software specifications
 - Hardware Specifications
 - Organizational integration specifications
 - c) State and explain three ways that can be followed to replace the current system. (6 marks)
 - Running in parallel: New system runs along side the old one until the old one is discarded -
 - Cut-over: New system replaces the old one instantly.
 - Phased: New system is implemented in phases.
 - Pilot sites: New system is tested on pilot sites then whole organization.
20. A head teacher keeps the following student details in a database: Name, Address, Town, Date of Birth, Marks scored, Fees paid.
- i) Name the most appropriate primary key. Give a reason. (2 marks)

Name

- Name alone is not unique though it is very rare that two or more students will share the same name.
 - ii) For each item in the student's details above, indicate its most appropriate data type as used in the database. (3 marks)

<i>Name</i>	<i>Text</i>
<i>Address</i>	<i>Text</i>
<i>Town</i>	<i>Text</i>
<i>Date of Birth</i>	<i>Date/Time</i>
<i>Mark Scored</i>	<i>Numeric</i>
<i>Fees Paid</i>	<i>Numeric/Currency</i>
 - iii) a) Explain why input screens are better data entry designs than entering data directly to a table. (2 marks)
 - Most forms are bound to one or more tables and query in the database hence a user can design input fields linked to several tables/queries.
 - Forms are also appealing to the eye. They have GUI features unlike a table.
 - b) List two career opportunities associated with databases. (2 marks)

Database Administrator

Data Administrator System Analyst

Database Developer

- c) **Distinguish between:**
- i) **A table in word-processing application and a table in a database application. (2 marks)**
- *A table in a database application is a data entry/storage object, while a table in a word processor is made up of rows and columns of cells that one can fill with text and graphics. Tables in word processors are often used to organize and present information*
 - *In a database one defines the data type for a table in design stage/view but not the case in a word processor.*
- ii) **Mouse pointer and insertion point. (2 marks)**
- *Mouse pointer* refers to an indicator on the screen, which responds to the movement of the mouse
 - *Insertion point* is the place, in a full-screen editor or drawing program, where characters will appear if you start typing. The insertion point, which is different from the mouse pointer, looks like a thin vertical bar or, in some contexts, a tall, thin letter "I"; it is relocated by clicking at the desired position.
- d) **Outline the steps to be followed in order to merge cells in a word processing table. (2 marks)**
- i) *Select/Highlight cells to be merged.*
 - ii) *Prom the menu bar clicks on table.*
 - iii) *Click on merge cells under the menu items.*

COMPUTER 2009

SECTION A (40 MARKS)

Answer ALL the questions in this section in the spaces provided

1. Give a reason for each of the following
 - (a) Changing a password regularly (1 mk)
 - (b) Typing and re- typing a new password when changing it (1 mk)
2. With reference to quality of print, noise level and cost, compare a dot matrix with a laser printer (3 mks)
3. A computer accessories vendor needs to order supplies. A spreadsheet is used to calculate the order part of which is shown below.

	A	B	C	D
1.	Item	Price per unit	Number ordered	Cost (Kshs)
2.	56 K modem	8,565.00	60	
3.	128 MB Ram	4, 950.00	40	
4.	Pentium IV Processor	13,525.00	55	
5.			Total	

(a) Write the formula that can be used in:

(i) D2 (1 mk)

(ii) D5 (1 mk)

(b) If a value added tax (VAT) of 16% was charged on each item and the number ordered was decreased by 10%, write a new formula that can be used in D2 (2 mks)

4. List two uses of computers in meteorology (2 mks)

5. Explain the following terms as used in desktop publishing (2 mks)

(a) Embedded object

(b) Auto flow

6. (a) Name four approaches that may be used to replace a computerized Information system (2 mks)

(b) Which of the approaches named in (a) above is appropriate for critical systems? Explain (2 mks)

1. Explain the following operating systems functions

(a) Job scheduling (1 mk)

- (b) Interrupt handling (1 mk)
2. Name four toggle keys on a standard computer keyboard (2 mks)
3. A computer user typed the name Kajiado as Kajiado and 8726 as 8126
- (a) State the type of each error (1 mk)
- (b) Explain how such errors can be controlled (2 mks)
4. Describe third generation languages and name two examples (2 mks)
5. (a) (i) What is an internet Protocol (IP) address? (1 mk)
- (ii) Why is an IP address necessary? (1 mk)
- (b) What is the purpose of the following internet domains? (1 mk)
- (i) .org
- (ii) .gov
6. (a) name two types of buses found on the computer motherboard (2 mks)

- (b) State the purpose of each of the types of buses named in (a) above (2 mks)
7. (a) Name the two files commonly used in mail merge (1 mk)
(b) Name and explain the two types of drop caps (2 mks)
8. Give three ways in which horticultural farmers can benefit from the use of information and communication Technology (ICT) (3 mks)
9. Arrange the following job titles in the order of their seniority
Database administrator, ICT manager, systems analyst (1 mk)

SECTION B (60 MARKS)

Answer question 16 and other three questions from this section in the spaces provided

10. Study the flowchart below and answer the questions that follow

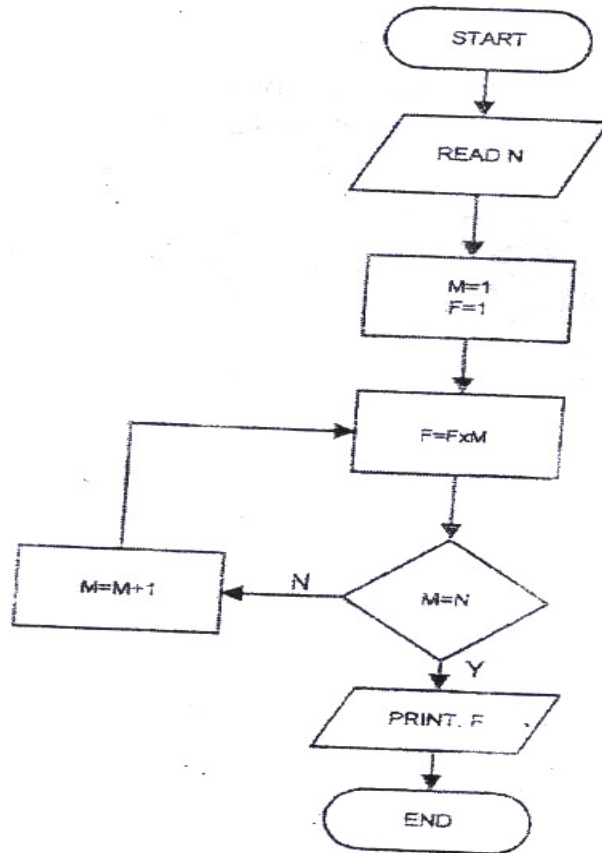

(a) What would the flowchart generate as output if the value of N at input was:

(i) 6? (2 mks)

(ii) 1? (2 mks)

(b) Write a pseudocode that does the same thing as the flowchart above

(7 mks)

(c) Modify the flowchart so as to reject an input below and to avoid the looping when the input is 0 (4 mks)

11. A lecturer keeps the following student details in a database: name, age, course

(a) write an expression you would use to compute the year of birth of a student using this year as the current year (2 mks)

(b) what query expressions would the lecturer use to list the students whose age is above 15 years and below 25 years? (3 mks)

(c) Which expression would the lecturer use to generate?

(i) The number of students in the database? (2 mks)

(ii) The mean age of the students in the database? (2 mks)

(d) Name and describe any two types of database models (6 mks)

12. (a) The diagram below shows a layout of a computer network used by a law firm.

A workstation and a printer are located in every consulting room

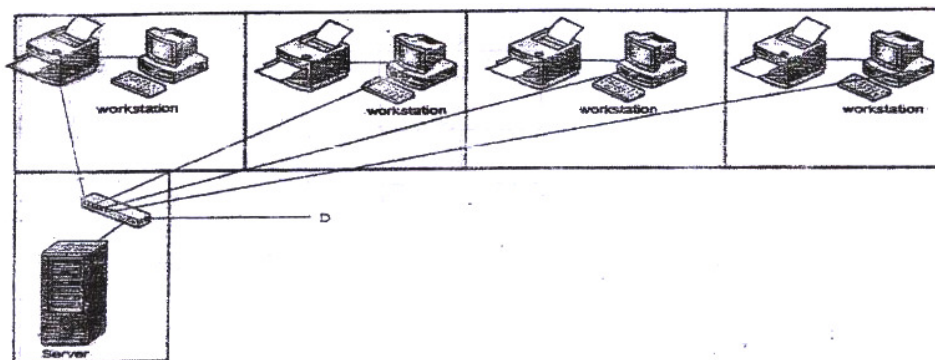

- (i) Name the network topology depicted in the diagram (1 mk)
- (ii) Name the device labeled D (1 mk)
- (iii) State four functions of the device labeled 'server' (4 mks)
- (iv) Give two advantages and one disadvantage of the above network design
(3 mks)
- (v) If the firm intends to open extra offices in two different towns, name any
three hardware devices that would be required (3 mks)
- (vi) State any two security problems that might arise by linking the offices in
different towns (2 mks)
- (b) What is spyware? (1 mk)

13. (a) Study the following diagram and answer the questions that follow

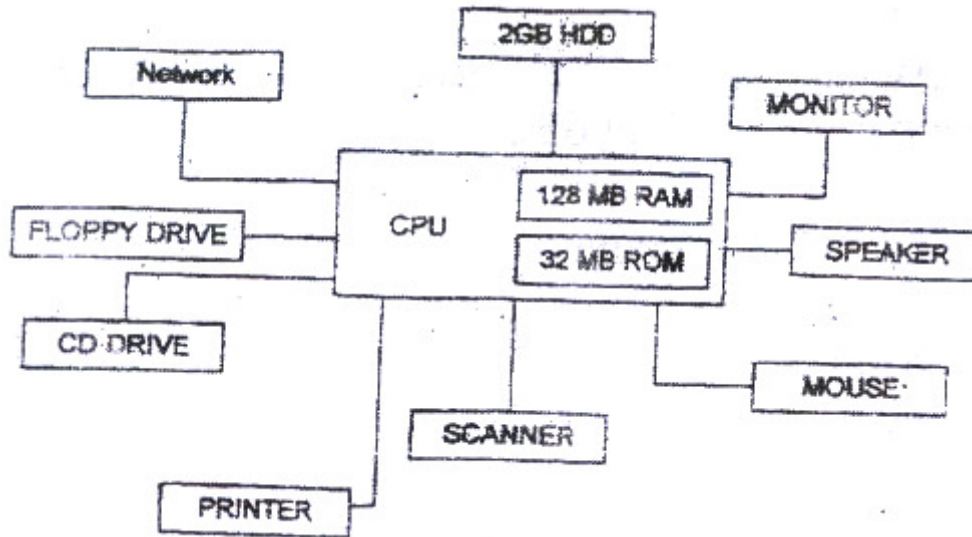

From the diagram:

- (i) Name two devices that are used for long term storage (2 mks)
- (ii) Name three peripherals shown on the diagram that are used for input (3 mks)
- (iii) Name two other devices that a computer Aided Design (CAD) user might wish to add to the set- up above (2 mks)
- (b) A customer wishes to purchase a computer system. The customer can buy a word processor, spreadsheet, database and a drawing package separately or as an integrated package. State three advantages why many computer users prefer integrated packages to separate packages.
- (c) (i) An anti- virus software installed in a computer is loaded into the main memory each time the computer is switched on

Explain three ways in which computer virus are spread from one computer to another

(3 mks)

(ii) Give two reasons why an anti virus package should be updated regularly

(2 mks)

14. (a) Perform the following binary arithmetic and give your answers in decimal notation:

(i) $1010.101 + 11.011$ (3 mks)

(ii) $1010.011 - 11.011$ (3 mks)

(b) Covert the following numbers into their binary equivalents

(i) 0.5625_{10} (3 mks)

(ii) 0.3125_{10} (3 mks)

(c) Using four – bit twos compliment, perform the following arithmetic

1. Design a newspaper publication to appear as indicated in the next page using the following instruction.

(a) Launch the DTP package and set the preference measurements to centimeters and the document margins to 2 cm on all sides (2 mks)

(b) The headings “digital Bulletin’ to have the following styles (4 mks)

- Centered across the page
- Font face: Arial
- Font size: 45
- Background colour: grey

(c) The other two headings in the publication to have the styles

- Font face: Ariel narrow
- Font size: 20
- Text weight: Bold
- Character spacing: 150%
- Alignment: centered across the page (5 mks)

(d) The text under the heading “Basic Networking and Connectivity’ to be in three columns and having the following styles (22 mks)

- Font size: 14
- First character of the paragraph to have a 3 lines drop cap
- Hyphenation: disabled
- Fully justified

(e) The text under the heading ‘Antivirus Information Corner’ to be in a single column (3 mks)

(f) Design the Mercury Digishop advertisement in the position shown

(10 mks)

(g) Insert the two lines of 4 and 0.75 points respectively in their positions

(3 mks)

(h) Print the publication

(1 mk)

DIGITAL BULLETIN

Basic Networking and Connectivity

The ability to expand beyond the limit of a single office has extended the reach of the PC to global proportions. Two technologies have driven this expansion; a computer network and the global network known as the internet.

A network is defined as two or more computers linked together for the purpose of communicating and sharing

information and other resources. Most networks are constructed around cable connection that link computers. This connection permits the computers to talk (and listen) though a wire. More recently, a number of wireless solutions have become available. Infrared Ports,

Bluetooth, radio links and other protocols allow variety of new devices to link with PCs. In order for the network to function, three basic requirement must be met:

- The network must provide connections, communication and services
- Connection include the hardware (physical components) required to hook up

- a computer to the network.
- **Communication** establishes the rules concerning how computers talk and understand each other. Computers often run different software and therefore they must speak a shared language
- A service defines those things a computer shares with the rest of the network. For example, a computer can share a printer or specific directories or files. Unless computers on the network are capable

SPECIAL OFFER

SPECIAL OFFER

Pentium IV

Duo 1.8 Ghz Intel,

120Gb HDD, 512 Mb

Memory, keyboard, full

multimedia

35,000/=

Antivirus Information Corner

Viruses are small programs that hide themselves on your disk (diskettes and hard disks).

Unless you use virus detection software the first time that you know that you have a virus is when it is active. Different viruses are activated in different ways, for instance, the famous

Friday the 13th virus will activate only when it is both a Friday and the 13th of the month.

Be aware, virus can destroy all your data.

2. The central bank of Kenya (CBK) exchange rates on a certain day for foreign currencies against the Kenya shillings (Kshs) were as follows

Currency	CBK Mean Rate (Kshs)
1 US Dollar	67.0222
1 sterling pound	137.7984
1 Euro	96.6552
1 S.A Rand	10.3100
1 Swedish Kroner	10.4509

Kariuki, Hamisi, Mumbua, Otieno and Nekesa trade in buying and selling of foreign currencies. On that day they bought the following foreign currencies from CBK.

Name	U.S Dollars	Sterling Pounds	Euros	S.A Rands	Swedish Kroner
Kariuki	400	200	340	1200	290
Hamisi	500	400	400	2000	3000
Mumbua	200	600	300	4000	5000
Otieno	600	200	200	1000	3000
Nekesa	400	200	600	2000	1000

They then sold their foreigners currencies at the following rates

Name	U.S Dollars	Sterling Pounds	Euros	S.A Rands	Swedish Kroner
Kariuki	70.5	139.0	96.7910	10.4213	10.6725
Hamisi	69.0	138.5	96.79	10.5712	10.2676
Mumbua	70.0	141.5	96.76	10.3974	10.7432
Otieno	69.55	139.0	96.80	10.6371	10.5942
Nekesa	69.5	138.5	96.40	10.7218	10.6155

(a) Using a spreadsheet package, represent the above information in one worksheet and save it as FOREX (13 mks)

(b) Using formulae with absolute and relative cell references, determine the total profit made by each trader. (14 mks)

(c) Format the profit for each trader to zero decimal places (2 mks)

(d) Create a well labeled bar graph on a different worksheet showing the cost incurred on buying US dollars by each trader (13 mks)

(e) Use a function to determine the trader who got the highest profit (3 mks)

(f) Format the first table as follows:

- Set the direction of the labels to 45⁰ (2 mks)

- Centre vertically all the records (1 mk)

(g) Print the worksheet and the graph (2 mks)

