

# **KCSE 2024 REGIONAL MOCKS**

## **MATHEMATICS**

*The PDF Comprises of A Compilation of 4  
Top Joint National Mocks Administered  
across the 47 Counties for KCSE Class of  
November 2024*

**For Marking Schemes:**

**Call/ Text/ Whatsapp  
0724333200/0795491185/  
0768321553**

***Mr Machuki***

**Or**

**Visit or website**

**[www.kenyaeducators.co.ke](http://www.kenyaeducators.co.ke)**

**KENYA EDUCATORS CONSULTANCY**

# ***Table of Contents***

<b>1.</b>	<b>Nairobi &amp; Central Joint National mocks 2024</b>
<b>2.</b>	<b>Nyanza &amp; Western Joint National mocks 2024</b>
<b>3.</b>	<b>Coastal &amp; Eastern Joint National mocks 2024</b>
<b>4.</b>	<b>Rift Valley &amp; North Eastern Joint National mocks 2024</b>

**Confidential!!!**

***Success to all KCSE 2024 Candidates***

**KENYA EDUCATORS CONSULTANCY**

**MINISTRY OF EDUCATION (KNEC COMPLIANT)**

**NAME** ..... **INDEX NO** .....

**SCHOOL** ..... **DATE** .....

**ADM No** ..... **CLASS** .....

**CANDIDATE'S SIGNATURE** .....

**121/1**

**MATHEMATICS**

**PAPER 1**

**CLASS OF KCSE 2024**

**TIME: 2<sup>1</sup>/<sub>2</sub> HOURS**

**THE NAIROBI & CENTRAL REGIONS KCSE JOINT  
NATIONAL MOCK 2024**

*Kenya Certificate of Secondary Education (K.C.S.E)*

**INSTRUCTIONS TO THE CANDIDATES**

*Write your name and school and index number in the spaces provided above*

- *This paper contains two sections; Section 1 and Section 11.*
- *Answer all the questions in section 1 and only five questions from Section 11*
- *Show all the steps in your calculations, giving your answers at each stage in the spaces below each question.*
- *Marks may be given for correct working even if the answer is wrong.*
- *Non-Programmable silent calculators and KNEC Mathematical tables may be used EXCEPT where stated otherwise.*

**FOR EXAMINERS'S USE ONLY**

**Section 1**

Question	1	2	3	4	5	6	7	8	9	10	11	12	13	14	15	16	Total
Marks																	

**Section 11**

**GRAND TOTAL**

Question	17	18	19	20	21	22	13	24	Total
Marks									

*This paper consists of 16 printed pages. Candidates should check carefully to ascertain that all the pages are printed as indicated and no questions are missing.*

**MINISTRY OF EDUCATION (KNEC COMPLIANT)**

**SECTION I (50 Marks)**

**Answers all the questions in this section in the space provided.**

1. Evaluate without using tables or calculators (3marks)

$$\frac{\sqrt{45} \times (2.04)^2}{2.89 \times \sqrt{0.05}}$$

2. Momanyi spent one eighth of his February Salary on farming, half on school fees and two thirds of the remainder on food. Calculate his February salary and the amount he spend on school fees if he spent sh. 3200 on food. (3marks)

3. Makau, Wanjiru and Kemboi start a race at 9.03 a.m in the same direction to run round a circular course. Makau makes the circuit in 252 seconds, Wanjiru in 308 seconds and Kemboi in 198 seconds. If they start from the same point, at what time will they next be all at the starting point together? (3marks)

**MINISTRY OF EDUCATION (KNEC COMPLIANT)**

4. Use squares square roots and reciprocal tables to evaluate (3marks)

$$3.045^2 + \frac{1}{\sqrt{49.24}}$$

5. Simplify the expression

$$\frac{9t^2 - 25a^2}{6t^2 + 19at + 15a^2} \quad (3marks)$$

6. A square based brass plate is 2mm high and has a mass of 1.05kg. The density of the brass is 8.4g/cm<sup>3</sup>. Calculate the length of the plate in centimeters. (3 marks)

**MINISTRY OF EDUCATION (KNEC COMPLIANT)**

7. The currency exchange rates of a given bank in Kenya are as follows;

Currency	Buying	Selling
1 sterling pound	135.50	135.97
1 US dollar	72.23	72.65

A tourist arrived in Kenya with 5,000 US dollars which he converted to Kenya shillings upon arrival. He spent ksh.214, 500 and converted the remaining to sterling pounds. How many pounds did he receive?

(3marks)

8. The figure below shows a simple tent.  $AF=FB=10\text{cm}$ ,  $AB=12\text{cm}$  and  $BC=FE=AD=20\text{cm}$ . On the tent, a tight rope is tied as shown on the diagram from  $BD$ ,  $DE$  and  $EA$ . Draw the net of the tent and show the path of the rope on the net using the scale  $1\text{cm rep. }5\text{cm}$  (3marks)

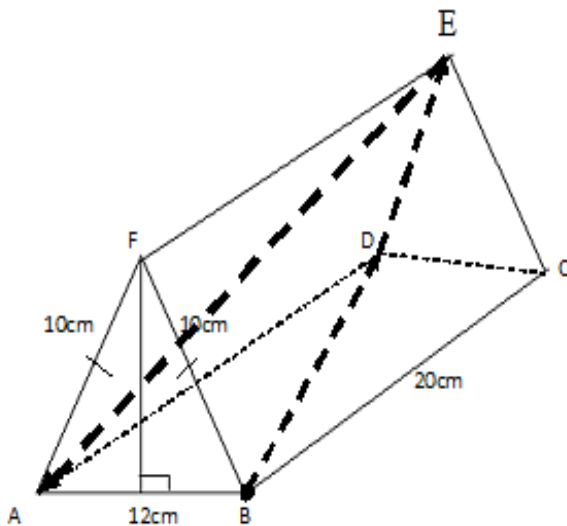

**MINISTRY OF EDUCATION (KNEC COMPLIANT)**

9. Mrs Wekesa paid shs 12500 for a wrist watch after the shopkeeper gave her a discount of 2%. If the shopkeeper made a profit of 20%.calculate the price the shopkeeper bought from the manufacturer. (3marks)

10. Solve for x in  $\left(\frac{4}{9}\right)^x \times (8)^{1-x} = 486$  (4marks)

11. Find the equation of a perpendicular bisector of line PQ if the coordinates of P and Q are (-2,6) and (4,-2) respectively, in the form  $y = mx + c$  (3marks)

**MINISTRY OF EDUCATION (KNEC COMPLIANT)**

12. Complete the figure below by adding the correct missing features if it has a rotational symmetry of order 4 about O. (3marks)

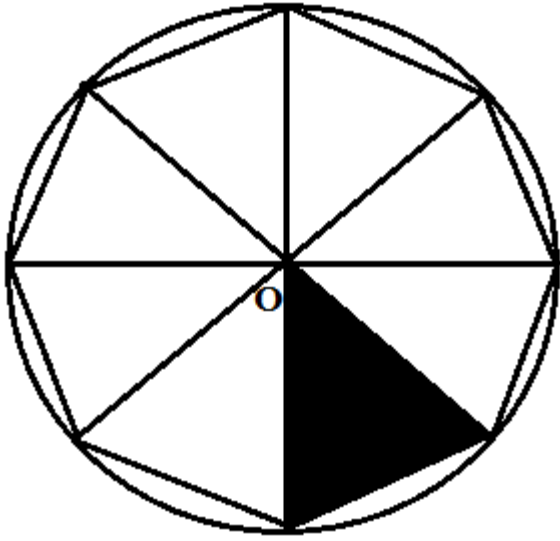

13. The volumes of two similar cylindrical containers are  $27\text{cm}^3$  and  $125\text{ cm}^3$  respectively. Given that the height of the smaller container is 12cm, find the height of the larger container. (3marks)

14. Without using calculator or mathematical tables, simplify (4marks)

$$\frac{\cos 30 - \sin 45}{\sin^2 30 + \tan^2 45}$$



**MINISTRY OF EDUCATION (KNEC COMPLIANT)**

15. Form three inequalities that satisfy the unshaded region R. (3marks)

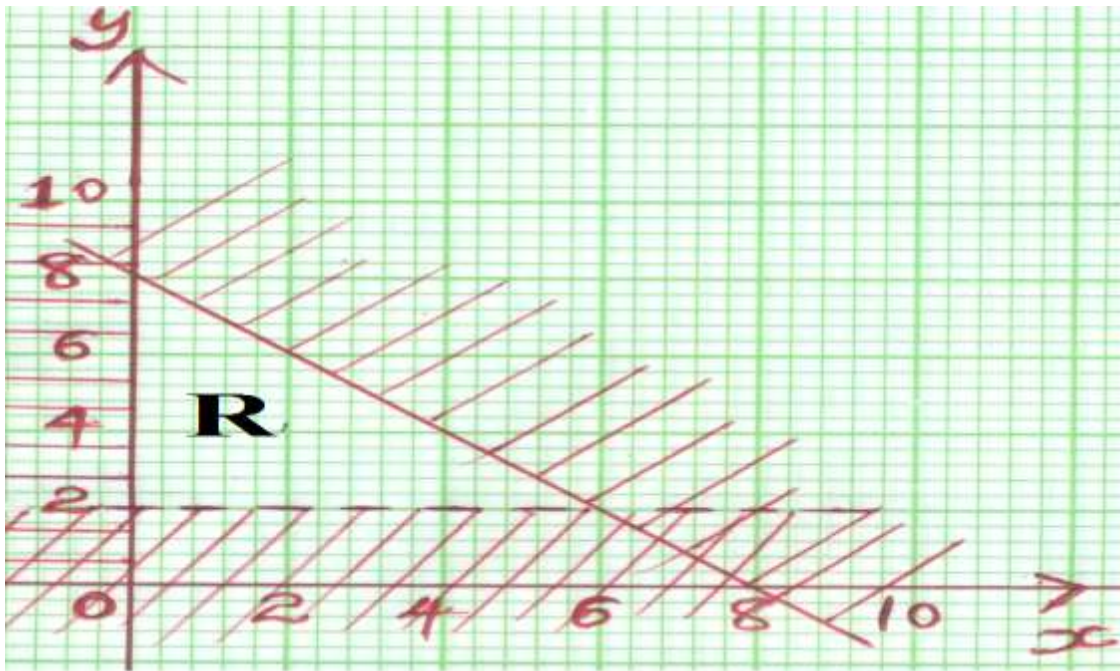

16. A railway line and a road are parallel to each other on a flat and level section of land. A 5 metre long car moving at a speed of  $110\text{kmh}^{-1}$  starts overtaking a train which is 495 metres and moving at  $80\text{kmh}^{-1}$ . How long will it take the car to completely overtake the train? (3marks)

**MINISTRY OF EDUCATION (KNEC COMPLIANT)**

**SECTION II (50 Marks)**

Answers only **five** questions from this section in the spaces provided.

17. The vertices of a parallelogram are O (0,0), A(5,0),B(8,3) and C(3,3)

Plot on the same axes

i) Parallelogram O'A'B'C', the image of OABC under reflection in the line x=4  
(4marks)

ii) Parallelogram O''A''B''C'' the image of O'A'B'C' under a transformation described by the matrix  $\begin{pmatrix} 0 & -1 \\ 1 & 0 \end{pmatrix}$ . Describe the transformation. (4marks)

iii) Parallelogram O'''A'''B'''C''', the image of O''A''B''C'' under the enlargement, centre (0,0) and scale factor  $\frac{1}{2}$ . (2marks)

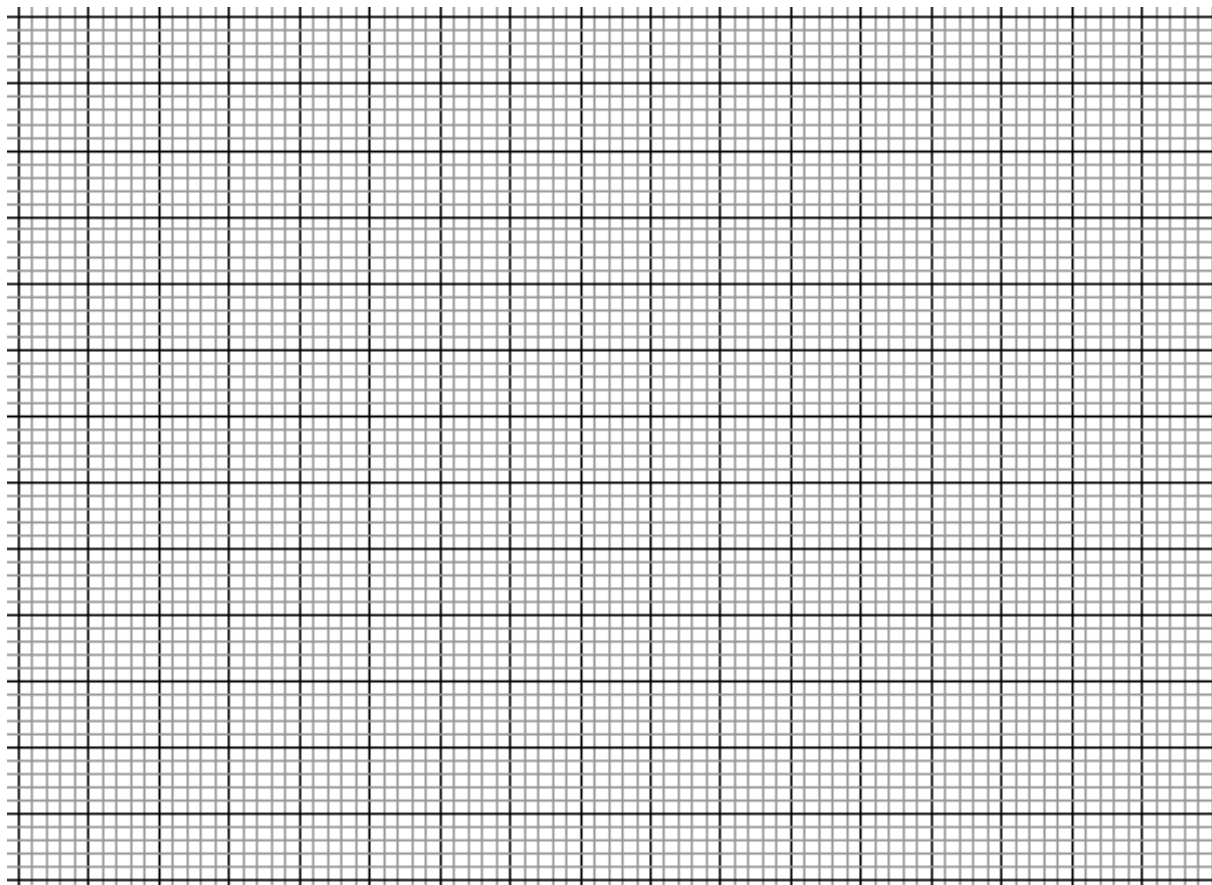

**MINISTRY OF EDUCATION (KNEC COMPLIANT)**

18. Two circles with centres O and Q and radii 8cm intersect at points A and B as shown below.

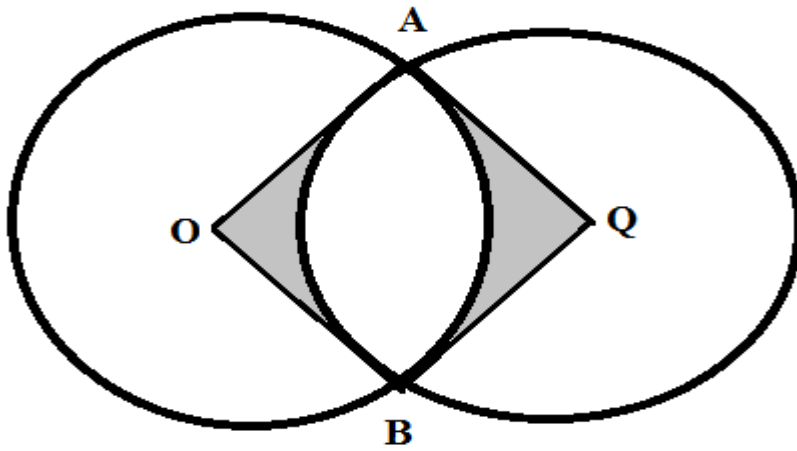

Given that the distance between O and Q is 12cm and that the line AB meets OQ at X, find:

(a) the length of the chord AB. (3marks)

(b) the reflex angle AOB. (3marks)

(c) the area of the shaded region.  $\pi = 3.142$  (4marks)

**MINISTRY OF EDUCATION (KNEC COMPLIANT)**

19. In the figure below, EG is the diameter of the circle centre O. Points B, G, D, E and F are on the circumference of the circle.  $\angle BFD = 50^\circ$ ,  $\angle BEO = 25^\circ$  and line ABC is a tangent to the circle at B

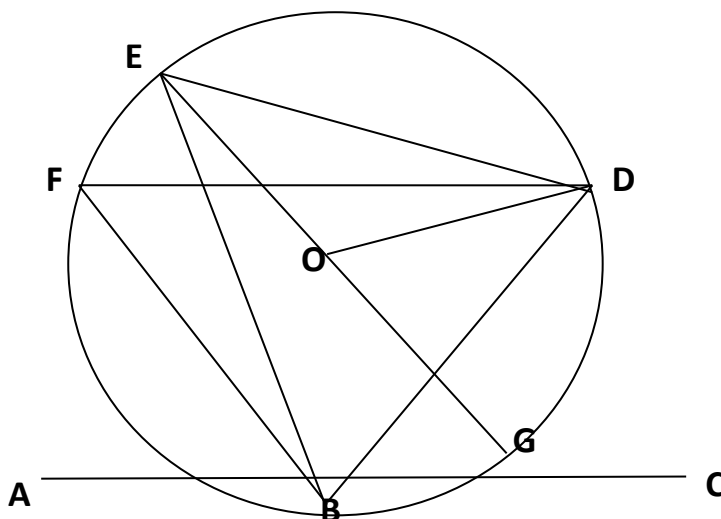

Giving reasons, calculate the size of

- (a)  $\angle CBD$  (2marks)
- (b)  $\angle BED$  (2marks)
- (c) The reflex angle  $BOD$  (2marks)
- (d)  $\angle EBA$  (2marks)
- (e)  $\angle BGD$  (2marks)

**MINISTRY OF EDUCATION (KNEC COMPLIANT)**

20. OAB is a triangle in which  $OA = \mathbf{a}$ ,  $OB = \mathbf{b}$ , M is a point on OA such that  $OM:MA=2:3$  and N is another point on AB such that  $AN:NB = 1:2$ . Lines ON and MB intersect at X.

a) Express the following vectors in terms of  $\mathbf{a}$  and  $\mathbf{b}$

i)  $\mathbf{AB}$  (1mark)

ii)  $\mathbf{ON}$  (1mark)

iii)  $\mathbf{BM}$  (1mark)

b) If  $\mathbf{OX} = k \mathbf{ON}$  and  $\mathbf{BX} = h \mathbf{BM}$ , express  $\mathbf{ON}$  in two different ways. Hence or otherwise find the value of h and k (6marks)

c) Determine the ratio OX: XN (1mark)

**MINISTRY OF EDUCATION (KNEC COMPLIANT)**

21. Every Sunday Alex drives a distance of 80km on a bearing of  $074^{\circ}$  to pick up his brother John to go to church. The church is 75km from John's house on a bearing of  $S50^{\circ}E$ . After church they drive a distance of 100km on a bearing of  $260^{\circ}$  to check on their father before Alex drives to John's home to drop him off then proceeds to his house.

(a) Using a scale of 1cm to represent 10km, show the relative positions of these places. (4 marks)

(b) Use your diagram to determine:

(i) the true bearing of Alex's home from their father's house.

(1 mark)

(ii) the compass bearing of the father's home from John's home.

(1 mark)

(iii) the distance between John's home and the father's home.

(2 marks)

**MINISTRY OF EDUCATION (KNEC COMPLIANT)**

(iv) the total distance Alex travels every Sunday. (2 marks)

22. The data below shows the sample of age distribution of some of the people who reside in a Yoruba village in years.

Age group	Number of persons in age group
1 - 5	4
6 - 10	12
11 - 20	9
21 - 30	6
31 - 50	18
51 - 55	4
56 - 65	2

(a) Complete the frequency distribution table above and hence

(i) Calculate the mean. (3marks)

(ii) Calculate the median. (2marks)

**MINISTRY OF EDUCATION (KNEC COMPLIANT)**

- (b) Draw a frequency polygon from the given data on the grid below  
(5marks)

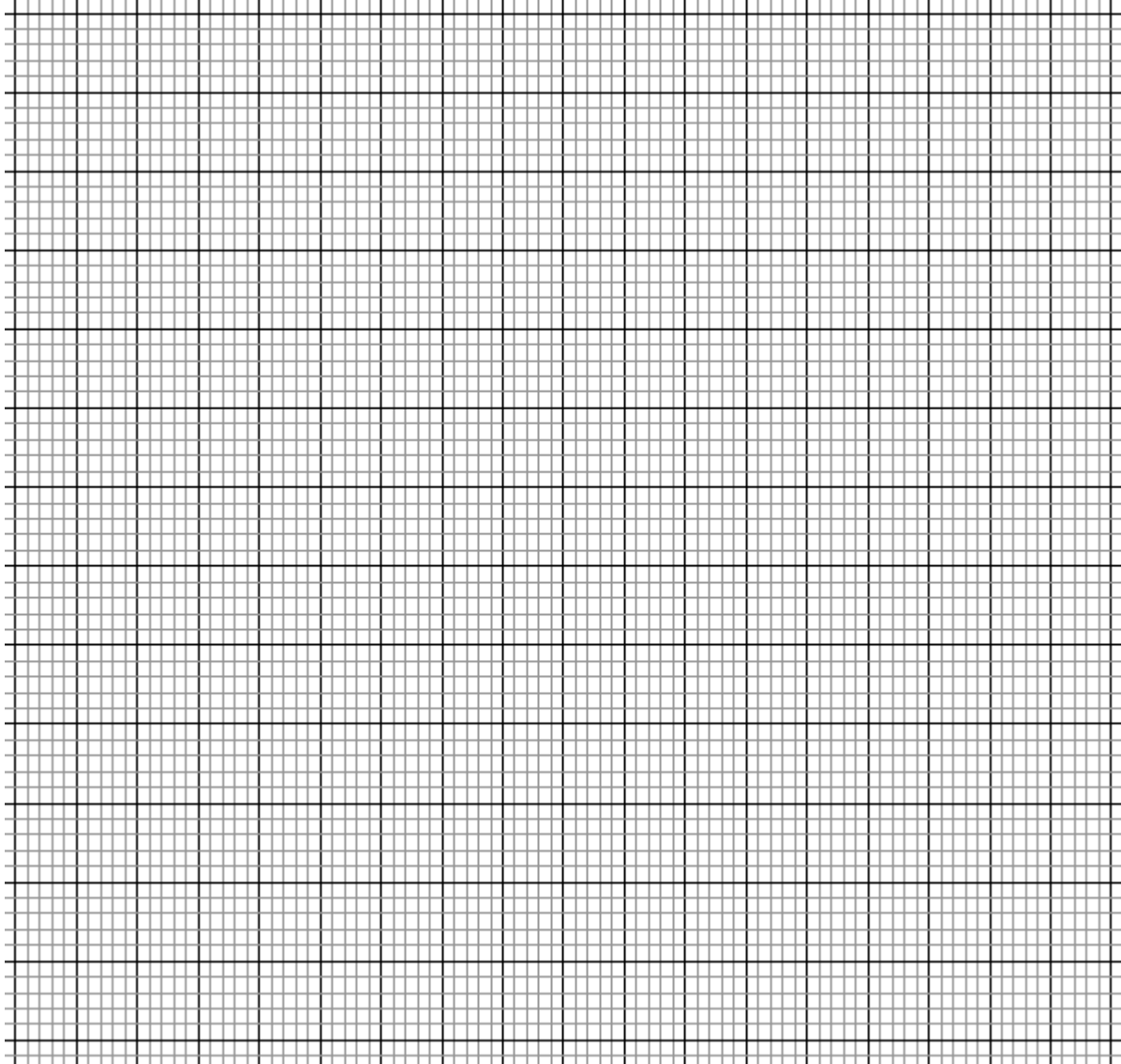



**MINISTRY OF EDUCATION (KNEC COMPLIANT)**

23. Two variables  $x$  and  $V$  are known to satisfy the relation  $V = Kx^n$  where  $k$  and  $n$  are constants. The table below shows data collected from an experiment.

X	3.01	3.98	5.01	6.02	7.08	8.94
V	10.5	101	989	9600	95000	854000

a) Write down the function  $V = Kx^n$  in linear form and make a suitable table of values correct to one decimal place. (3marks)

b) Draw a suitable graph to represent the relation  $V = Kx^n$

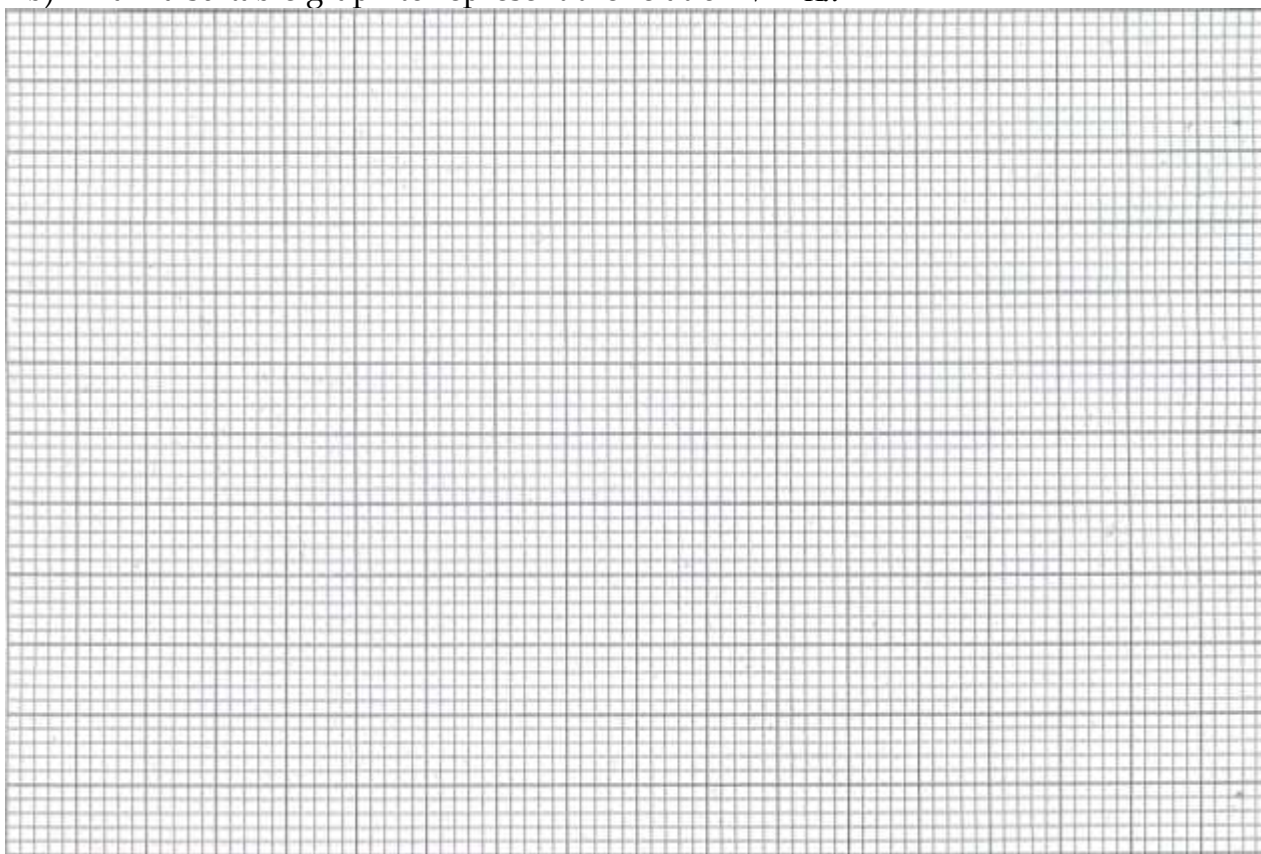

c) Use your graph to determine the values of  $k$  and  $n$  (4marks)

**MINISTRY OF EDUCATION (KNEC COMPLIANT)**

24. A particle moves in a straight line. It passes through point O at  $t = 0$  with velocity  $V = -4m/s$ . The acceleration  $a \text{ m/s}^2$  of the particle at time  $t$  seconds after passing through O is given by  $a = 10t + 1$

(a) Express the velocity  $V$  of the particle at time  $t$  seconds in terms of  $t$ . (3marks)

b) Find  $V$  when  $t = 3$  (1mark)

c) Determine the value of  $t$  when the particle is momentarily at rest (3marks)

d) Calculate the distance covered by the particle between  $t = 2$  and  $t = 4$  (3marks)

**MINISTRY OF EDUCATION (KNEC COMPLIANT)**

NAME ..... INDEX NO .....

SCHOOL ..... DATE .....

ADM No ..... CLASS .....

CANDIDATE'S SIGNATURE .....

121/2

MATHEMATICS

PAPER 2

CLASS OF KCSE 2024

TIME: 2<sup>1</sup>/<sub>2</sub> HOURS

**THE NAIROBI & CENTRAL REGIONS KCSE JOINT**

**NATIONAL MOCK 2024**

*Kenya Certificate of Secondary Education (K.C.S.E)*

**INSTRUCTIONS TO CANDIDATES:**

- Write your name, index number, admission and class in the spaces provided above.
- Sign and write the date of examination in the spaces provided above.
- This paper contains **TWO** sections: Section I and Section II.
- Answer **ALL** the questions in Section I and **FIVE** questions from section II.
- All answers and working **MUST** be written on the question paper in the spaces provided below each question.
- Marks may be given for correct working even if the answer is wrong.
- Non-programmable silent electronic calculators and KNEC Mathematical tables may be used, except where stated otherwise.

**FOR EXAMINERS USE ONLY**

**SECTION I**

1	2	3	4	5	6	7	8	9	10	11	12	13	14	15	16	Total

**SECTION II**

17	18	19	20	21	22	23	24	Total

Grand  
Total

--

**MINISTRY OF EDUCATION (KNEC COMPLIANT)**

1. Use logarithm table to evaluate (4marks)

$$\sqrt[5]{\frac{75.4 \times 4.83^2}{0.00521}}$$

2. Make b the subject of the formula given that  $a = \frac{bd}{Nb^2 - d}$  (3 marks)

3. Line PQ is the diameter of a circle such that the coordinates of P and Q are (-2, 2) and (-2,-6) respectively. Find the equation of the circle in the form  $ax^2 + ay^2 + bx + cy + d = 0$ . (4marks)

**MINISTRY OF EDUCATION (KNEC COMPLIANT)**

4. Use completing the square method to solve the equation  
 $4 - 3x - 2x^2 = 0$  (3marks)

5. Given that  $P=4+\sqrt{2}$  and  $Q=2+\sqrt{2}$  and that  $\frac{P}{Q}=a+b\sqrt{c}$ , where a, b and c are constants, find the values of a, b and c. (3 marks)

6. The table below shows the temperature readings of four different solutions recorded by students to nearest  $0.1^{\circ}C$  during a laboratory lesson. Calculate the percentage error in  $\frac{P+Q}{S-R}$  to 3 d.p. (3marks)

Quantity	Temperature in $^{\circ}C$
P	22.5
Q	19.4
R	17.3
S	26.2

**MINISTRY OF EDUCATION (KNEC COMPLIANT)**

7. Use matrix method to solve the simultaneous equations  
 $2x + y = 10$   
 $2x + 2y = 14$  (3marks)
8. (a) Expand  $(1+2x)^5$  to the fourth term. (1 mark)
- (b) Hence evaluate  $(1.02)^5$  correct to 3 decimal places. (3 marks)
9. It is known that the value of land appreciate at 7% p.a in a town. John bought a plot in the town at Ksh 500,000. Given that he plans to sell the plot after 6 years, find out how much profit he expects to get. (Give your answer correct to the nearest thousand). (3marks)

**MINISTRY OF EDUCATION (KNEC COMPLIANT)**

10. The mass of a wire varies jointly with its length and with the square of its diameter. A section of the wire 500m long, with diameter 3mm has a mass of 31.5kg. what is the mass of 1000m of wire of diameter 2mm? (3marks)

11. Mr. Gatua has a salary of sh.80000 per annum. He lives rent free in company house and is entitled to a monthly personal relief of sh.1056. Based on the tax rates given below, calculate his PAYE. (3 marks)

<u>Taxable income</u> (KE p.a.)	<u>Rate</u>
1 - 1500	10%
1501 - 3000	15%
3000 - 4500	25%
Above 4500	35%

12. The third term and sixth term of a geometric series are  $3\frac{1}{3}$  and  $11\frac{1}{4}$  respectively. Calculate the common ratio and hence find its first term. (3marks)

**MINISTRY OF EDUCATION (KNEC COMPLIANT)**

13. Use the figure below to answer the question that follows

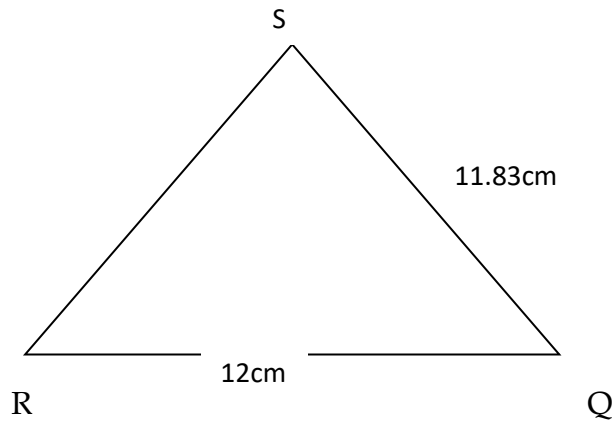

Given that angle  $RSQ = 50^\circ$ ,  $SQ = 11.83$  cm and  $QR = 12$  cm. A circumcircle is drawn on the triangle. Find the radius of the circle (2 marks)

14. A Business man bought commodity A and commodity B at shs.60 and sh.72 respectively. In what ratio must he mix so that when he sells at shs.78, he makes a profit of 200%. (3 marks)



**MINISTRY OF EDUCATION (KNEC COMPLIANT)**

15. Points A ( $x^{\circ}N, 30^{\circ}E$ ) and B ( $x^{\circ}N, 50^{\circ}E$ ) are 1935 kilometres apart. Taking R=6370 km and  $\pi = \frac{22}{7}$ , find the value of  $x$ . (3marks)

16. Find the gradient function of the curve  $y = \frac{1}{3}x^3 - 4x^2 + 9x + 4$  hence, find the gradient of the curve at point (1,-4) (3marks)

**MINISTRY OF EDUCATION (KNEC COMPLIANT)**

17. Use a scale of 1:1 in both axes to draw the graphs of  $y = x^2 - 6x + 7$  and  $y = x - 2$  for the domain  $0 \leq x \leq 6$ . The point of intersection of the two functions satisfy a certain quadratic equation in  $x$ . Obtain the equation in  $x$  hence calculate it's solutions. Give answer correct to 2d.p. (10 marks)

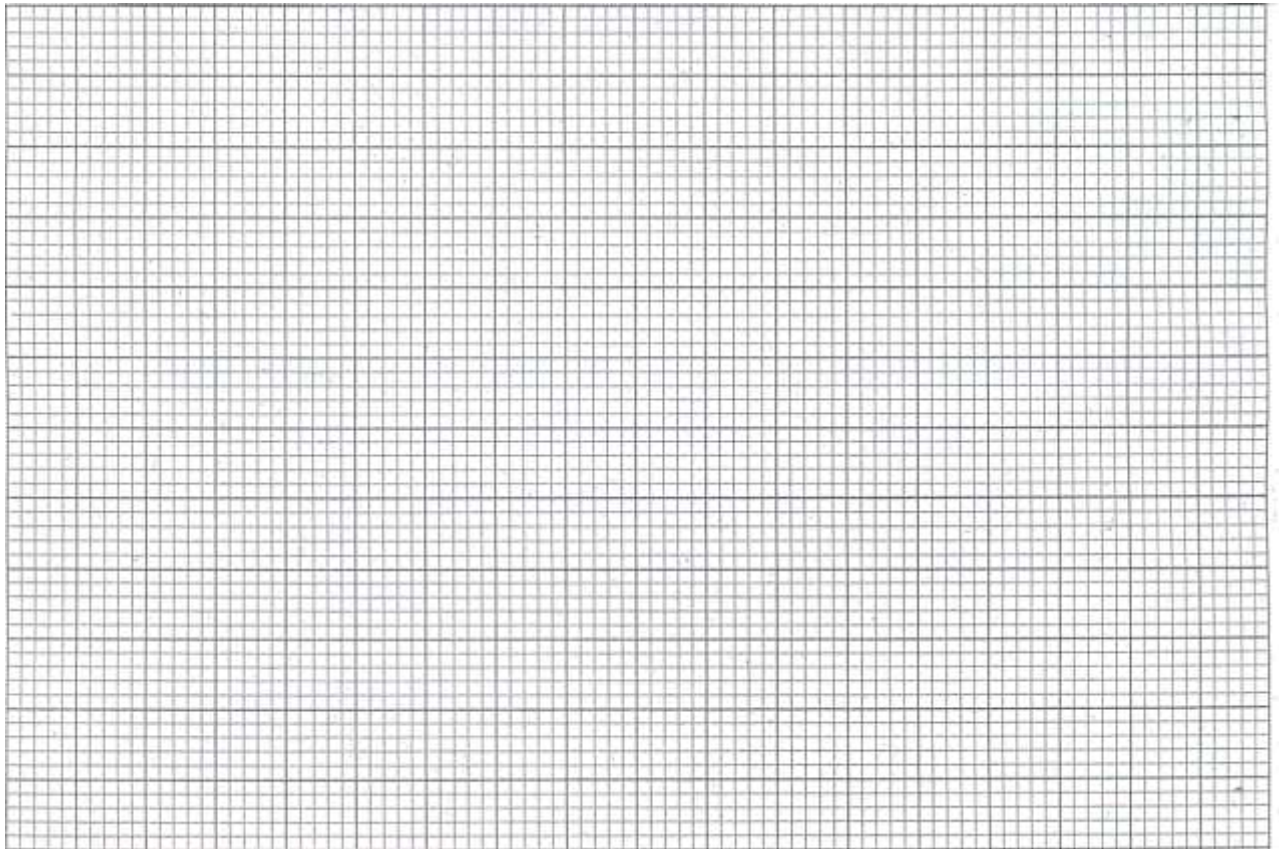

**MINISTRY OF EDUCATION (KNEC COMPLIANT)**

18. Points A and B are centres of two equal circles of a radius 2 cm and 10 cm apart.
- i. Construct the two circles in the space given below. (1mark)
  - ii. Construct the transverse common tangents to both circles. (4marks)
  - iii. Calculate the length of the transverse common tangents (Take  $\pi = \frac{22}{7}$ ) (5marks)

**MINISTRY OF EDUCATION (KNEC COMPLIANT)**

19. Albert, Bonny and Charles competed in a game of chess. Their probabilities of winning the game are  $\frac{2}{5}$ ,  $\frac{3}{5}$  and  $\frac{1}{10}$  respectively.
- (a) Draw a probability tree diagram to show all the possible outcomes. (2 marks)
- (b) Calculate the probability that;
- (i) No one loses the game. (2 marks)
- (ii) Only one of them wins the game. (2 marks)
- (iii) At least one of them wins the game. (2 marks)
- (iv) At most two of them lost the game. (2marks)

**MINISTRY OF EDUCATION (KNEC COMPLIANT)**

20. Construct rhombus ABCD such that  $AB=BC= 6\text{cm}$  and  $\angle ABC=60^\circ$ .
- (a) Measure BD. (1 mark)
- (b) On the same diagram, construct the inscribed circle of triangle ACD. (3marks)
- (c) Construct the locus of points equidistant from A and C. (3 marks)
- (d) If x is a point on the circle in b above such that  $AX=XD$  and  $\angle AXD$  is acute, find the locus of X and make it on the diagram. (3 marks)

**MINISTRY OF EDUCATION (KNEC COMPLIANT)**

21. (a) Complete the table below.

(2marks)

X	-180°	-150°	-120°	-90°	-60°	-30°	0°	30°	60°	90°	120°	150°	180°
Y=2cosx		-1.73			1		2		1	0			
Y=cos(x-60)	-0.5			-0.9		0			1				-0.5

(b) On the same axes plot the graphs of  $y= \cos(x-60^\circ)$  and  $y = 2 \cos x$  (use a scale of 1unit for  $30^\circ$  on the x axis and 1 unit for 0.5 units on the y axis)

(4mrks)

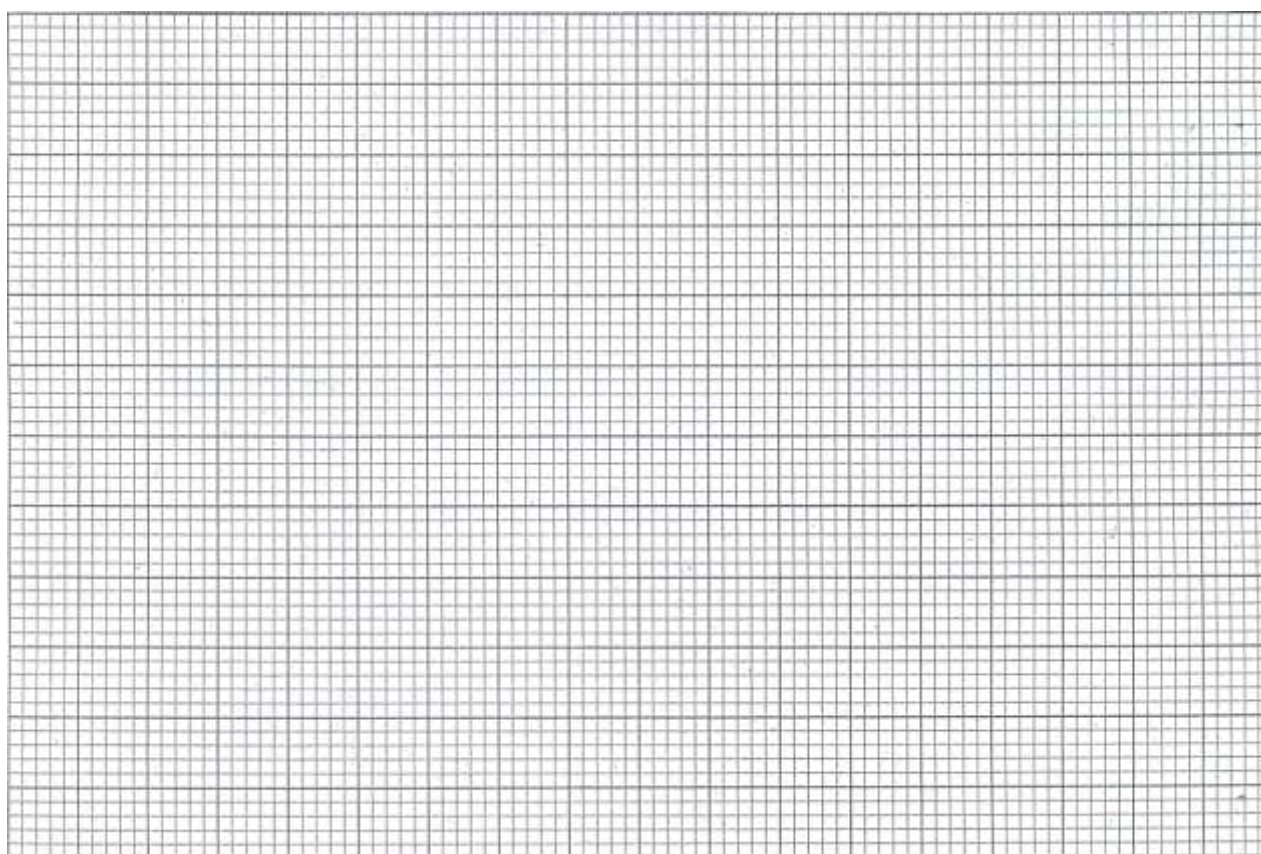

(c) Describe the transformation which maps  $y= \cos(x-60^\circ)$  to  $y = 2\cos x$ . (2marks)

(d) State the period and amplitude of each of the waves above. (1mark)

	Amplitude	Period
Y=2cosx		
Y=cos(x-60)		

(e) Using the graph above determine the values of x for which  $\cos(x-60^\circ) - 2\cos x = 0$

(1mark)

**MINISTRY OF EDUCATION (KNEC COMPLIANT)**

22.

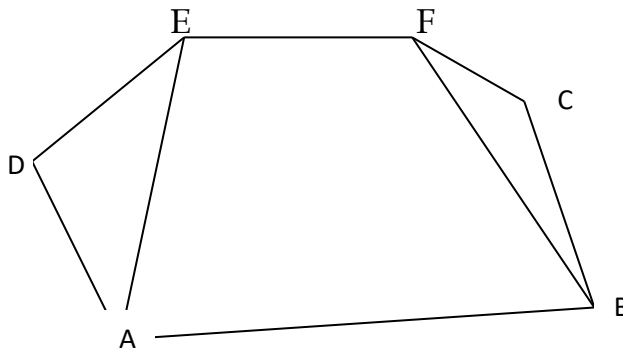

The roof of a building is as shown in the figure above with a rectangular base ABCD.  $AB = 20\text{m}$  and  $AD = 8\text{m}$ . The ridge  $EF = 10\text{m}$  and is centrally placed. The faces ADE and BFC are equilateral triangles. Calculate

- (i) The height of E above the base ABCD (2 marks)
  
  
  
  
  
  
  
  
  
  
- (ii) The angle between the planes ABCD and ADFE (3 marks)
  
  
  
  
  
  
  
  
  
  
- (iii) The angle between the planes AED and ABCD (2 marks)
  
  
  
  
  
  
  
  
  
  
- (iv) The acute angle between lines DB and EF (3 marks)

**MINISTRY OF EDUCATION (KNEC COMPLIANT)**

23. Kiprop has at least 50 acres of land on which he plans to plant potatoes and cabbages. Each are of potatoes requires 6 men and each are of cabbages requires 2 men. The farmer has 240men available and he must plant at least 10 acres of potatoes. The profit on potatoes is kshs.1200 per acre. If he plants  $x$  acres of potatoes and  $y$  acres of cabbages;
- (a) Write down 3 in equalities in  $x$  and  $y$  to describe the information. (2 marks)
  - (b) Represent these in equalities graphically. (use a scale of 1:10 for both axes) (4 marks)
  - (c) Use your graph to determine the number of acres for each vegetable which will give maximum profit. (4 marks)

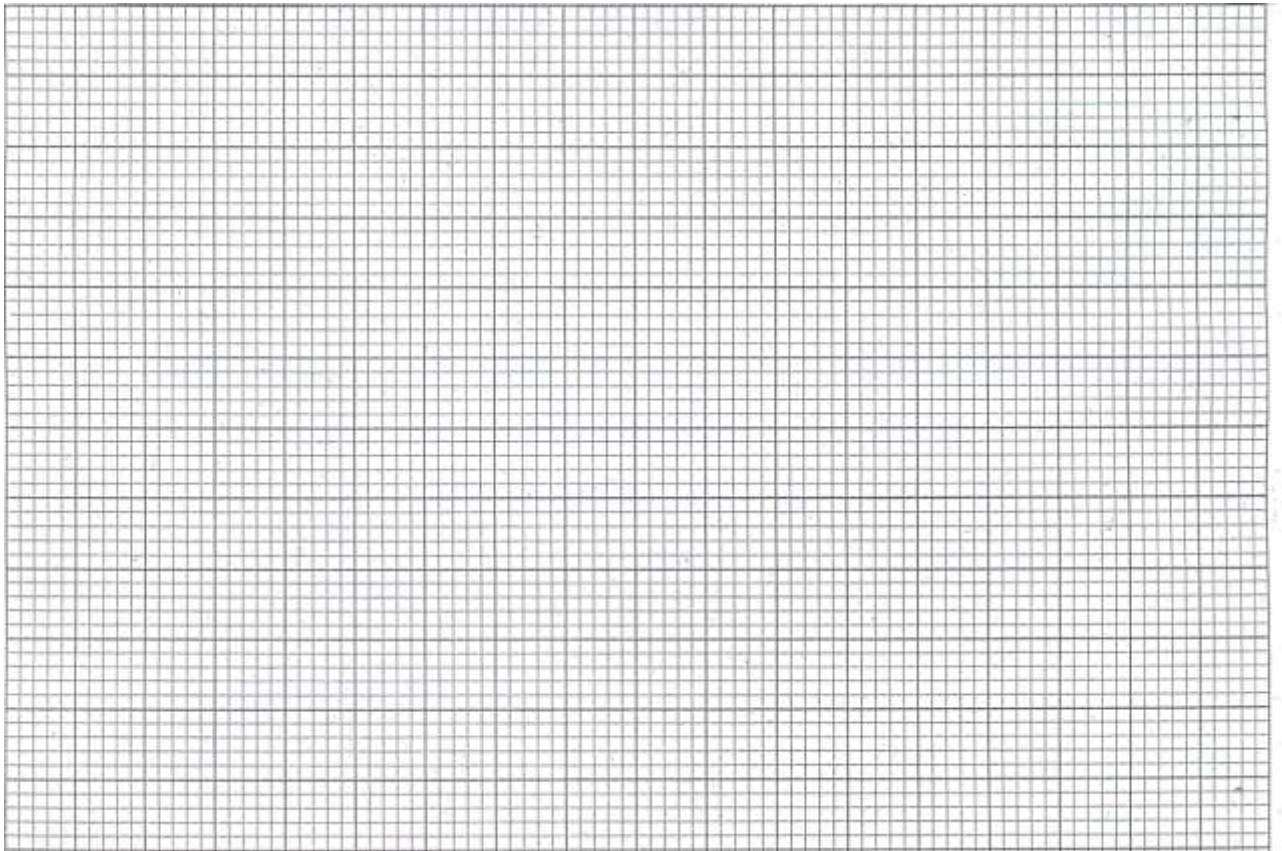



**MINISTRY OF EDUCATION (KNEC COMPLIANT)**

24. (a) Complete the table below for  $y = x^2 - 3x + 5$  in the range  $2 \leq x \leq 8$  (2marks)

x	2	3	4	5	6	7	8
y	3		9		23	33	

- (b) Use the trapezium rule with six strips to estimate the area enclosed by the curve, x-axis and the lines  $x=2$  and  $x=8$ . (2marks)
- (c) Find the exact area of the region given in (b). (4marks)
- (d) Calculate the percentage error in the area. (2marks)

**MINISTRY OF EDUCATION (KNEC COMPLIANT)**

NAME.....ADMNO.....CLASS.....

121/1

**MATHEMATICS**

**Paper 1**

**Class of KCSE 2024**

**2½ Hours**

**THE NYANZA & WESTERN REGIONS KCSE  
JOINT NATIONAL MOCKS 2024**  
*Kenya Certificate of Secondary Education (KCSE)*  
**MATHEMATICS**

**INSTRUCTIONS TO CANDIDATES**

1. Write your name, index number and class in the spaces provided above.
2. The paper contains two sections: **Section I** and **Section II**.
3. This paper contains **14 PRINTED** pages make sure all **PAGES ARE PRINTED** and **NON IS MISSING**
4. Answer **ALL** the questions in **Section I** and **ANY FIVE** questions from **Section II**.
5. All working and answers must be written on the question paper in the spaces provided below each question.
6. Marks may be awarded for correct working even if the answer is wrong.
7. Negligent and slovenly work will be penalized.
8. Non-programmable silent electronic calculators and mathematical tables are allowed for use.

**For examiners use only**

**Section I**

1	2	3	4	5	6	7	8	9	10	11	12	13	14	15	16	Total

**MINISTRY OF EDUCATION (KNEC COMPLIANT)**

**Section II**

17	18	19	20	21	22	23	24	Total

**Grand**

**Total**

--

**SECTION I (50 marks)**

Answer **all** the questions in this section in the spaces provided.

1. Without using Mathematical tables or a calculator, evaluate

$$\frac{(-8) \times 4 + 156 \div 2 \text{ of } (-43 + 30)}{(-3) - (-8) \times 2 + 6}$$

(3 marks)

2. Antony spent one quarter of his net January salary on school fees. He spent a quarter of the remainder on electricity and water bills. He then spent one ninth of what was left on transport. If he finally had sh. 3 400, calculate his net January salary.

(3 marks)

3. A residential estate is to be developed on a 6 hectares piece of land. 1 500 m<sup>2</sup> is taken up by the roads while the rest is divided into 40 equal plots. Calculate the area of each plot.

(3 marks)

**MINISTRY OF EDUCATION (KNEC COMPLIANT)**

4. The equation of a straight line  $L_1$  is  $3y + 4x - 6 = 0$ . Another straight line  $L_2$  is perpendicular to  $L_1$  and passes through point P  $(-3, 6)$ . Determine the equation of  $L_2$  in the form  $y = mx + c$ , where  $m$  and  $c$  are constants.  
(3 marks)

5. A shopkeeper bought a number of eggs for which he paid a total of Ksh. 1000. Four eggs were broken. He sold the rest at  $13\frac{1}{3}\%$  profit, thereby making a cash profit of Ksh. 100. Calculate the number of eggs that he had bought at the first place.  
(3 marks)

6. Without using Mathematical tables a calculator evaluate  $\frac{243^{-\frac{2}{5}} \times 125^{\frac{2}{3}}}{9^{-\frac{3}{2}}}$  (3 marks)

**MINISTRY OF EDUCATION (KNEC COMPLIANT)**

7. The longest side of a right-angled triangle is  $(2x)$  cm. The other sides are  $(x + 3)$  cm and  $(2x - 4)$  cm. Find the value of  $x$  and hence the lengths of the sides of the triangle. (4 marks)

8. Below is part of sketch of a wedge ABCDEF. Complete the sketch of the solid, showing the hidden edges with broken lines. (3 marks)

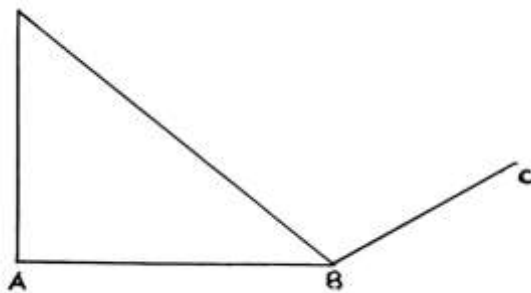

9. If  $x$  is a positive integer, solve the inequality  $2 < \frac{2x^2}{3} < 11$  and hence list the integral values that satisfy the inequality. (3 marks)

**MINISTRY OF EDUCATION (KNEC COMPLIANT)**

10. The matrix  $\mathbf{M} = \begin{pmatrix} k & k + 3 \\ 1 & 2k \end{pmatrix}$  has no inverse. Determine the possible values of  $k$ . (3 marks)

11. A Kenyan Bank buys and sells foreign currencies at the exchange rates shown below

	Buying	selling
	Kshs	Kshs
1 Euro	147.86	148.00
1 US Dollar	74.22	74.50

An American arrived in Kenya with 20000 Euros. He converted all the Euros to Kenya shillings at the Bank. He spent kshs.2,512, 000 while in Kenya and converted the remaining Kenya shillings into US Dollars at the bank. Find the amount in Dollars that he received. (3 marks)

12. Given that  $\tan(\theta + 20)^\circ = -0.7660$ , find  $\theta$ , to the nearest degree, in the range  $0^\circ \leq \theta \leq 360^\circ$ .

(3 marks)

**MINISTRY OF EDUCATION (KNEC COMPLIANT)**

13. The area of an island on a map of scale 1:100 000 is  $200 \text{ cm}^2$ . Calculate the actual area on the ground in square kilometers.  
(3 marks)

14. P(2, 1), Q(8, 11) and R(12, 19) are three points on a Cartesian plane. Show that P, Q and R are collinear.  
(3 marks)

15. A bus leaves Nairobi travelling towards Mombasa at a speed of  $70 \text{ kmh}^{-1}$ . Half an hour later, a car leaves Nairobi travelling in the same direction at a speed of  $90 \text{ kmh}^{-1}$ . Calculate the distance travelled by the car when it overtook the bus.  
(3 marks)

16. Use a ruler and a pair of compasses in this question.

(a) Construct a quadrilateral PQRS in which  $PQ = 4$  cm,  $QR = 6$  cm,  $PS = 3$  cm, angle  $PQR = 135^\circ$  and angle  $SPQ = 60^\circ$ .

(3 marks)

(b) Measure the length of RS.

(1 mark)



**MINISTRY OF EDUCATION (KNEC COMPLIANT)**

**SECTION II**

*Answer five questions only in this section.*

17. (a) Aisha sold 180 bags of rice in September 2017. The cost of each bag was sh. 2800.

Calculate the amount of money that he received from the sale of rice that month.

(1 mark)

- (b) (i) In October that year, the price of a bag of rice decreased by 24% and the number of bags that she sold increased by 30%. Determine the percentage decrease in the amount of money she received from the sale of rice.

(3 marks)

- (ii) In November that year, the price of a bag of rice changed in the ratio of 7:8. Find the

price of each bag in November.

(2 marks)

**MINISTRY OF EDUCATION (KNEC COMPLIANT)**

(c) The amount that he received from the sale of rice in September was sh. 1260 more than what was received in November. If the number of bags that were sold in November were  $t\%$  more than those sold in September, find  $t$  (4 marks)

18. (a) Complete the table below for the function  $y = 2x^2 - 3x - 4$  for  $-4 \leq x \leq 2$  (2 marks)

$x$	-2	-1	0	1	2	3
$2x^2$		2	0	2	8	
$-3x - 4$	2		-4			-13
$y$			-4			5

**MINISTRY OF EDUCATION (KNEC COMPLIANT)**

(b) On the grid below, draw the graph of  $y = 2x^2 - 3x - 4 = 0$  for  $-2 \leq x \leq 3$

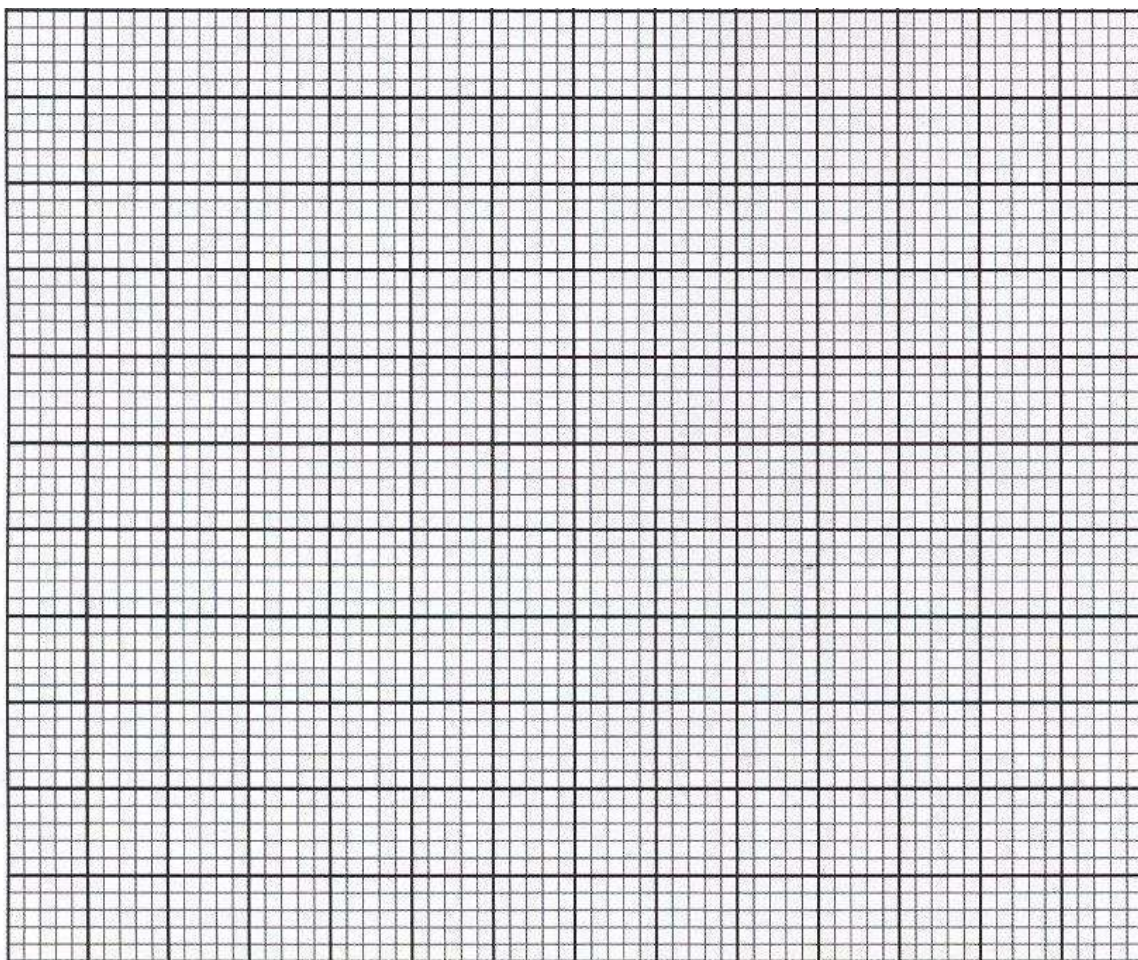

(3 marks)

(c) Use your graph to estimate the roots of  $y = 2x^2 - 3x - 4 = 0$  (2 marks)

(d) Use your graph to solve  $4x^2 - 7x = 12$  (3 marks)

**MINISTRY OF EDUCATION (KNEC COMPLIANT)**

19. The marks scored by a certain number of students in a mathematics contest are as shown in the table below.

Marks	45-49	50-54	55-59	60-64	65-69	70-74	75-79
No. of students	10	11	14	41	27	18	19

(a) Calculate to 2d.p. the mean of the marks scored. (4 marks)

(b) State the median class and hence calculate the median. (4 marks)

(c) Calculate the difference between the mean and the median. (1 mark)

(d) State the modal class. (1 mark)

**MINISTRY OF EDUCATION (KNEC COMPLIANT)**

20. The figure below shows a solid frustum of right pyramid with a rectangular base EFGH measuring 24cm by 7cm. The frustum was obtained by cutting off a small pyramid along plane ABCD that is parallel to base EFGH. Plane ABCD measures 16.8cm by 4.9cm, and is exactly seven tenths way up the vertical height of the original pyramid.

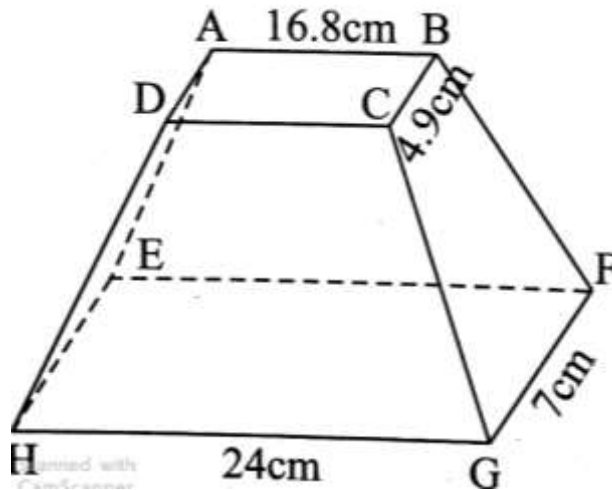

Given that the original pyramid had a slant edge of 32.5cm, find:

- (a) The altitude (perpendicular height) of the frustum. (4 marks)
- (b) The volume of the frustum (3 marks)
- (c) The surface area of the original pyramid. (3 marks)

**MINISTRY OF EDUCATION (KNEC COMPLIANT)**

21. Triangle ABC has vertices A(-6,5), B(0,1) and C(-2,-3). Triangle MNP is the image of triangle ABC under an enlargement. The vertices of triangle MNP are M(-4,6), N(-1,4) and P(-2,2). A reflection then maps triangle MNP onto triangle XYZ whose vertices are X(7,-5), Y(5,-2) and Z(3,-3).

(a) Plot the three triangles on the grid below. (3 marks)

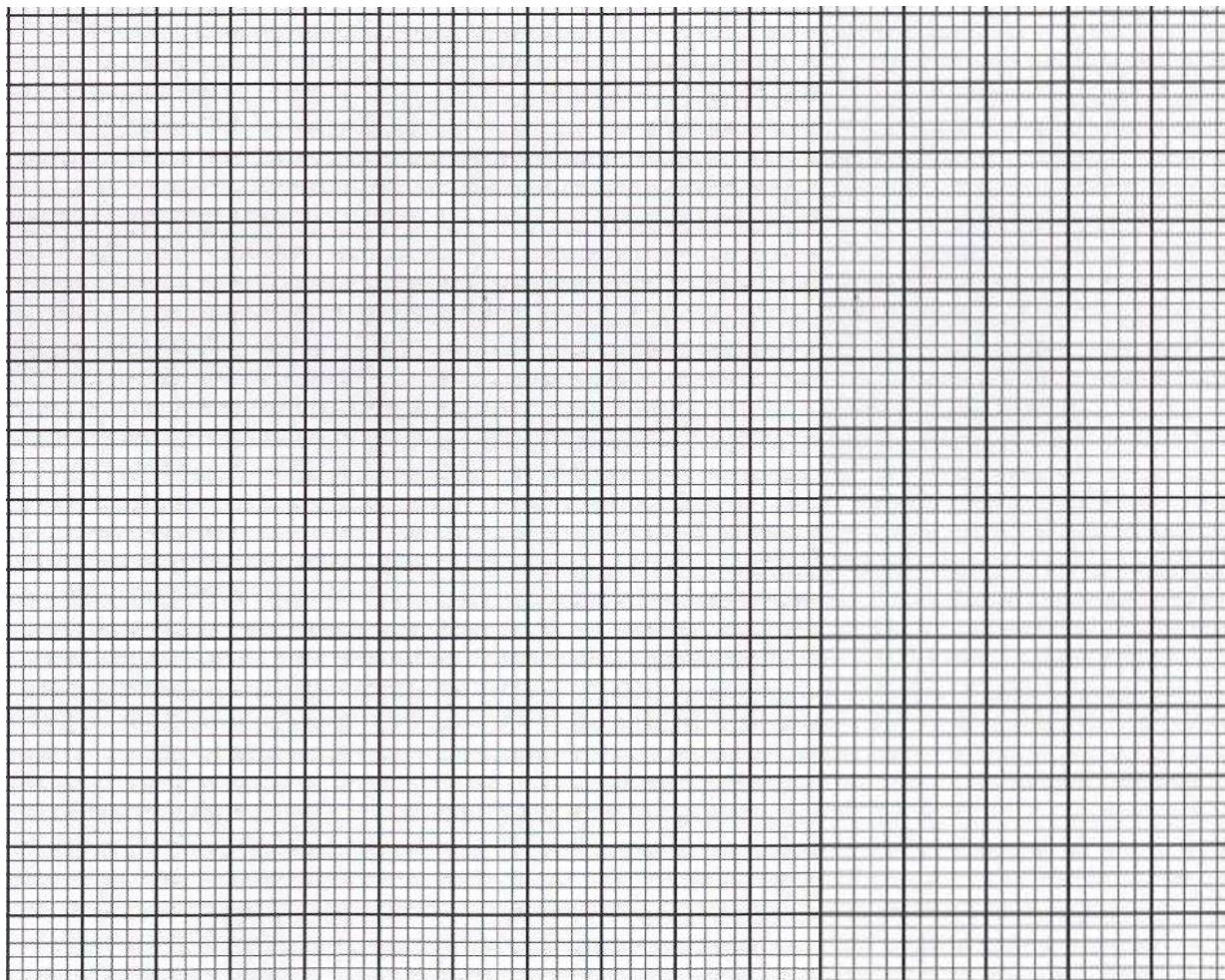

(b) Determine the centre and the scale factor of enlargement that maps ABC onto MNP (3 marks)

(c) Find the equation of the mirror line of the reflection. (2 marks)

(d) Given that triangle XYZ has an area of  $Q\text{cm}^2$ , state the area of triangle ABC in terms of  $Q$ . (2 marks)

**MINISTRY OF EDUCATION (KNEC COMPLIANT)**

22. In the figure below,  $AB = 11\text{cm}$ ,  $BC = 8\text{cm}$ ,  $AD = 3\text{cm}$ ,  $AC = 5\text{cm}$  and  $\angle DAC$  is a right angle.

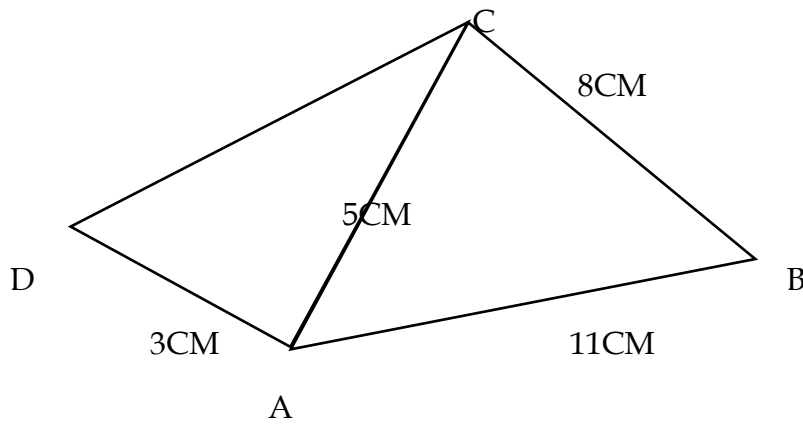

Calculate, correct to one decimal place:

(a) The length DC (2 marks)

(b) The size of  $\angle ADC$  (2 marks)

(c) The size of  $\angle ACB$  (3 marks)

(d) The area of the quadrilateral ABCD (3 marks)

**MINISTRY OF EDUCATION (KNEC COMPLIANT)**

23. Three warships P, Q and R are at sea such that ship Q is 400km on a bearing of  $030^{\circ}$  from ship P. Ship R is 750km from ship Q and on a bearing of  $120^{\circ}$  from ship Q. An enemy warship S is sighted 1000km due south of ship Q.

(a) Taking a scale of 1cm to represent 100km locate the relative positions of ships P, Q, R and S. (4 Marks)

(b) Find the compass bearing of

(i) P from S (1 mark)

(ii) S from R (1 mark)

(c) Use the scale drawing to determine the distance of;

(i) S from P (1 mark)

(ii) R from S (1 mark)

(d) Find the bearing of;

(i) Q from R (1 mark)

(ii) P from R (1 mark)



**MINISTRY OF EDUCATION (KNEC COMPLIANT)**

24. A particle moving along a straight line passes through a fixed point P. Its displacement  $S$  metres from P after a period of  $t$  seconds is given  $S=t^3-5t^2+3$ . Find;

(a) The particle's displacement from P at  $t=4$  (2 marks)

(b) The particle's velocity at  $t = 4$ . (3 marks)

(c) The possible Value(s) of  $t$  when the particle is momentarily at rest (3 marks)

(d) The acceleration of the particle at  $t = 3$ . (2 marks)

**MINISTRY OF EDUCATION (KNEC COMPLIANT)**

NAME.....ADMNO.....CLASS.....

121/2

**MATHEMATICS**

**Paper 2**

**Class of KCSE 2024**

**2½ Hours**

**THE NYANZA & WESTERN REGIONS KCSE**  
**JOINT NATIONAL MOCKS 2024**  
*Kenya Certificate of Secondary Education (KCSE)*  
**MATHEMATICS**

**Instructions to candidates**

- a. Write your name and index number in the spaces provided above.
- b. Sign and write the date of examination in the spaces provided above.
- c. This paper consists of **two** sections I, II.
- d. Answer **all** the questions in section **1** and **any five** questions from section II.
- e. All working and answers **must** be written on the question paper in the spaces provided below each question.
- f. Show **all** steps in your calculations, giving answers at each stage in the spaces provided below each question.
- g. Marks may be given for correct working even if the answer is wrong.
- h. Non-programmable silent electronic calculators and KNEC mathematical tables may be used.
- i. **This paper consists of 13 printed pages.**
- j. **Candidates should check the question paper to ascertain that all the pages are printed as indicated and that no questions are missing.**

**For Examiner’s Use Only.**

**SECTION I**

Questions	1	2	3	4	5	6	7	8	9	10	11	12	13	14	15	16	Total
marks																	

**SECTION II**

Questions	17	18	19	20	21	22	23	24	Total
Marks 17									

Grand

--

**MINISTRY OF EDUCATION (KNEC COMPLIANT)**

SECTION 1 (50MARKS)

1. Use logarithms to evaluate

(4mks)

$$4 \sqrt{\frac{(0.8932)^2 \times (582.3)^{1/3}}{(69.35)}}$$

2. A rectangular card measures 5.3cm by 2.5cm. find

a) The absolute error in the area of the card. (2mks)

b) The relative error in the area of the card (2mks)

3. Solve the equation

(4mks)

$$\sin(2x + 10)^\circ = -0.5 \text{ for } 0^\circ \leq x \leq 360^\circ$$

**MINISTRY OF EDUCATION (KNEC COMPLIANT)**

4. In a transformation, an object with an area of  $52\text{cm}^2$  is mapped onto an image whose area is  $30\text{cm}^2$ . Given that the matrix of the transformation is  $\begin{pmatrix} x & x - 1 \\ 2 & 4 \end{pmatrix}$  find the value of  $x$  (3mks)

**MINISTRY OF EDUCATION (KNEC COMPLIANT)**

5. Simplify  $\sqrt{48}$  leaving your answer in the form of  $a\sqrt{b} + c$  where a, b and c are integers. (3mks)

$$\frac{\quad}{\sqrt{5} + \sqrt{3}}$$

6. A customer deposited sh 14000 in a saving account. Find the accumulated amount after one year if interest was paid at 12% p.a compounded quarterly (3mks)

7. Expand  $(1+x)^5$ , hence use the expansion to estimate  $(1.04)^5$  correct to 4 decimal place (3mks)

**MINISTRY OF EDUCATION (KNEC COMPLIANT)**

8. Find the centre and the radius of circle whose equation is (3mks)  
 $x^2+4x+y^2-5=0$

**MINISTRY OF EDUCATION (KNEC COMPLIANT)**

9. Make  $d$  the subject of the formula (3mks)

$$P = \frac{1}{2}mn^2 - gd^2$$

$$\frac{\quad}{n}$$

10. In what proportion should grades of sugar costing sh 45 and sh 50 per kg be mixed in order to produce a blend worth sh 48 per kg (3mks)

11. Simplify the expression (3mks)

$$16m^2 - qn^2$$

$$\frac{\quad}{4m^2 - mn - 3n^2}$$

**MINISTRY OF EDUCATION (KNEC COMPLIANT)**

12. Find the equation of the tangent to the curve (3mks)  
 $y=2x^2$  at  $(2, 3)$

13. Use matrix method to solve the given simultaneous equation (3mks)  
 $3x+y=7$   
 $5x+2y=12$

14. The sum of  $n$  terms of the sequence 3, 9, 15, 21 ... is 7500. Determine the value of  $n$  (3mks)



**MINISTRY OF EDUCATION (KNEC COMPLIANT)**

15. The figure below (not drawn to scale) shows a triangle ABC in which  $AB=6\text{cm}$ ,  $BC=9\text{cm}$ ,  $AC=10\text{cm}$ . calculate the radius of the circle touching the three vertices of the triangle. (3mks)

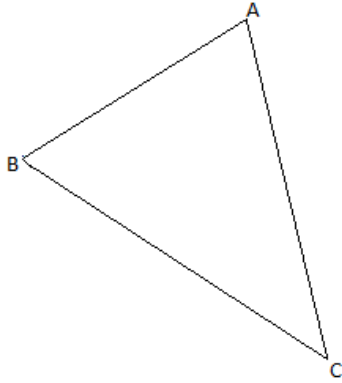

16. The point p ( $40^{\circ}\text{S}$ ,  $45^{\circ}\text{E}$ ) and point Q ( $40^{\circ}\text{S}$ ,  $60^{\circ}\text{W}$ ) are on the surface of the earth. Calculate the shortest distance along a circle of latitude between the two points. (3mks)

**MINISTRY OF EDUCATION (KNEC COMPLIANT)**

**SECTION B (ANSWER ANY FIVE QUESTION (50 MARKS))**

17. The table below shows monthly income tax rates.

Monthly taxable pay K£	Rate of tax sh per K£
1-342	2
343-684	3
685-1026	4
1027-1368	5
1369-1710	6
Over 1710	7

A civil servant earns a monthly salary of sh 20 000 and is provided with a house at a normal rent of sh 700 per month.

a) calculate the civil servant taxable pay in K£ (4mks)

b) Calculate the total tax (4mks)

**MINISTRY OF EDUCATION (KNEC COMPLIANT)**

- c) If the employee is entitled to a tax relief of sh 600 per month. What is the net tax paid? (2mks)

**MINISTRY OF EDUCATION (KNEC COMPLIANT)**

18. In an agricultural research centre, the length of a sample of 50 maize cobs were measured and recorded as shown in the frequency distribution table below.

Length in cm	Number of cobs
8-10	4
11-13	7
14-16	11
17-19	15
20-22	8
23-25	5

Calculate

a) The mean  
(2mks)

b) (i) the variance  
(5mks)

- (ii) The standard deviation  
(3mks)

**MINISTRY OF EDUCATION (KNEC COMPLIANT)**

19. In the diagram shown below O is the centre of the circle, angle  $\text{RTV}=150^\circ$ , and angle  $\text{RST}=50^\circ$ .

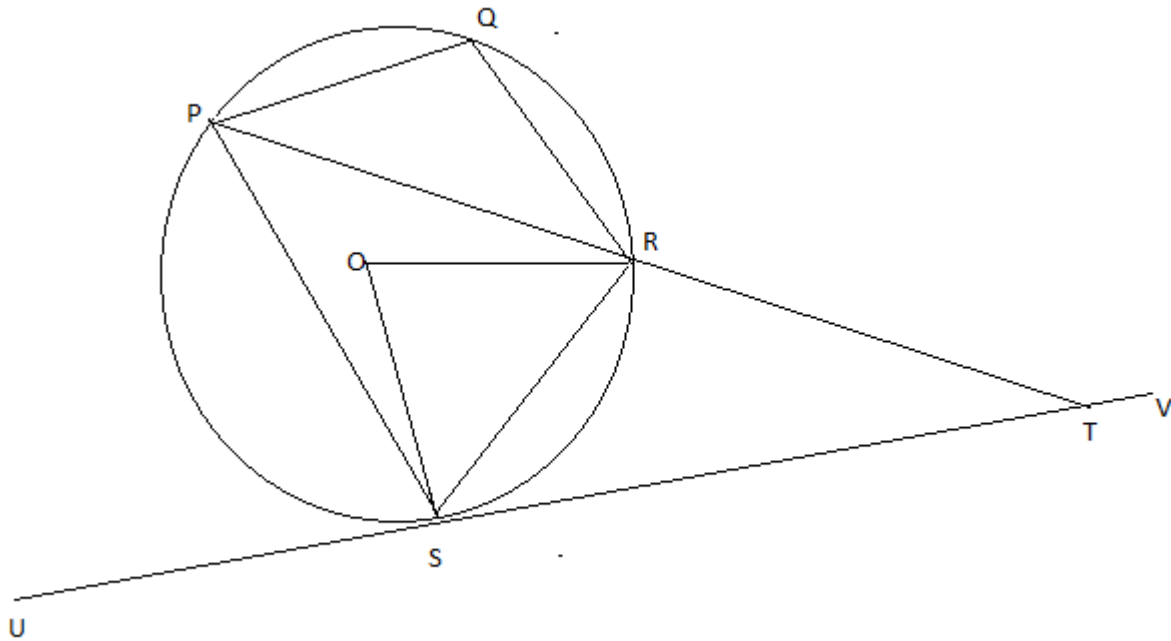

a) Calculate the size of

i.  $\angle \text{ORS}$   
(2mks)

ii.  $\angle \text{USP}$   
(1mk)

iii.  $\angle \text{PQR}$   
(2mks)

**MINISTRY OF EDUCATION (KNEC COMPLIANT)**

b) Given that  $RT = 7\text{cm}$  and  $ST = 9\text{cm}$ , calculate to 3.s.f

i. The length of line PR  
(2mks)

ii. The radius of the circle  
(3mks)

20. The position of two towns A and B on the earth surface are  $(36^{\circ}\text{N}, 49^{\circ}\text{E})$  and  $(36^{\circ}\text{N}, 131^{\circ}\text{W})$  respectively

a) Find the difference in longitude between town A and town B  
(2mks)

b) Given that the radius of the earth is  $6370\text{km}$  calculate the distance between town A and B  
(4mks)

(c) Another town C is  $840\text{km}$  east of town B and on the same latitude as towns A and B. find the longitude of town C  
(4mks)

**MINISTRY OF EDUCATION (KNEC COMPLIANT)**



**MINISTRY OF EDUCATION (KNEC COMPLIANT)**

21. The distance  $s$  m from a fixed point  $O$ , covered by a particle after  $t$  s is given by the equation

$$S=t^3-6t^2+9t+5$$

a) Calculate the gradient to the curve at  $t=0.5$ s  
(3mks)

b) Determine the values of  $s$  at the maximum and minimum turning points of the curve. (4mks)

**MINISTRY OF EDUCATION (KNEC COMPLIANT)**

- c) On the space provided sketch the curve of  $s=t^3-6t^2+9t+5$   
(3mks)

**MINISTRY OF EDUCATION (KNEC COMPLIANT)**

22. In the figure below  $OQ = a$  and  $OB = b$ .  $m$  is the midpoint of  $OA$  and  $AN:NB = 2:1$

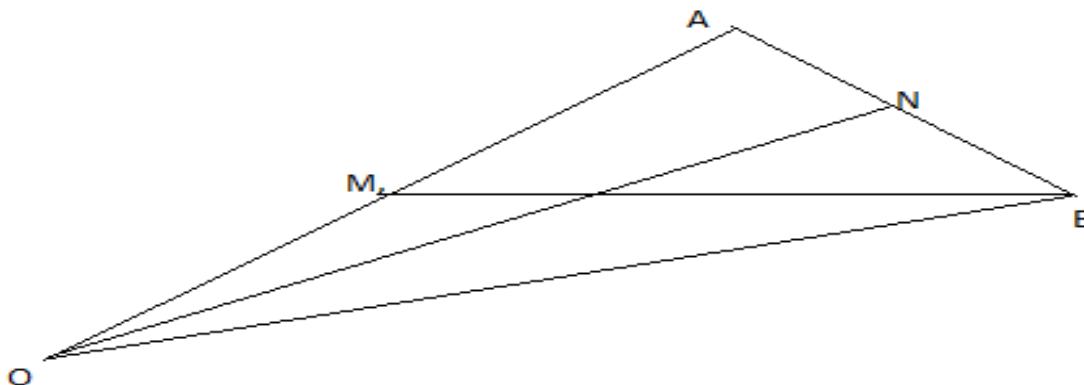

- a) Express in terms of  $a$  and  $b$
- i.  $\vec{BA}$  (1mk)
  - ii.  $\vec{BN}$  (1mk)
  - iii.  $\vec{ON}$  (2mks)
- b) Given that  $\vec{BX} = h\vec{BM}$  and  $\vec{OX} = k\vec{ON}$  determine the values of  $h$  and  $k$  (6mks)

**MINISTRY OF EDUCATION (KNEC COMPLIANT)**

23. (a) Complete the table below, giving the values correct to 1 d.p  
(2mks)

	$X^{\circ}$	0	40	80	120	160	200	240
$2\sin(x+20)^{\circ}$	0.7			2.0		0.0		-2.0
$\sqrt{3}\cos x$	1.7	1.3			-0.9		-1.6	

- (b) On the grid provided, using the same scale and axes, draw the graphs of  $y=2\sin(x+20)^{\circ}$  and  $y=\sqrt{3}\cos x$  for  $0\leq x\leq 240^{\circ}$   
(5mks)
- (c) Use the graphs drawn in (b) above to determine:
- i. The values of  $x$  for which  $2\sin(x+20)^{\circ}=\sqrt{3}\cos x$   
(2mks)

**MINISTRY OF EDUCATION (KNEC COMPLIANT)**

ii. The difference in the amplitudes of  $y=2\sin(x+20)$  and  $y=\sqrt{3}\cos x$  (1mk)

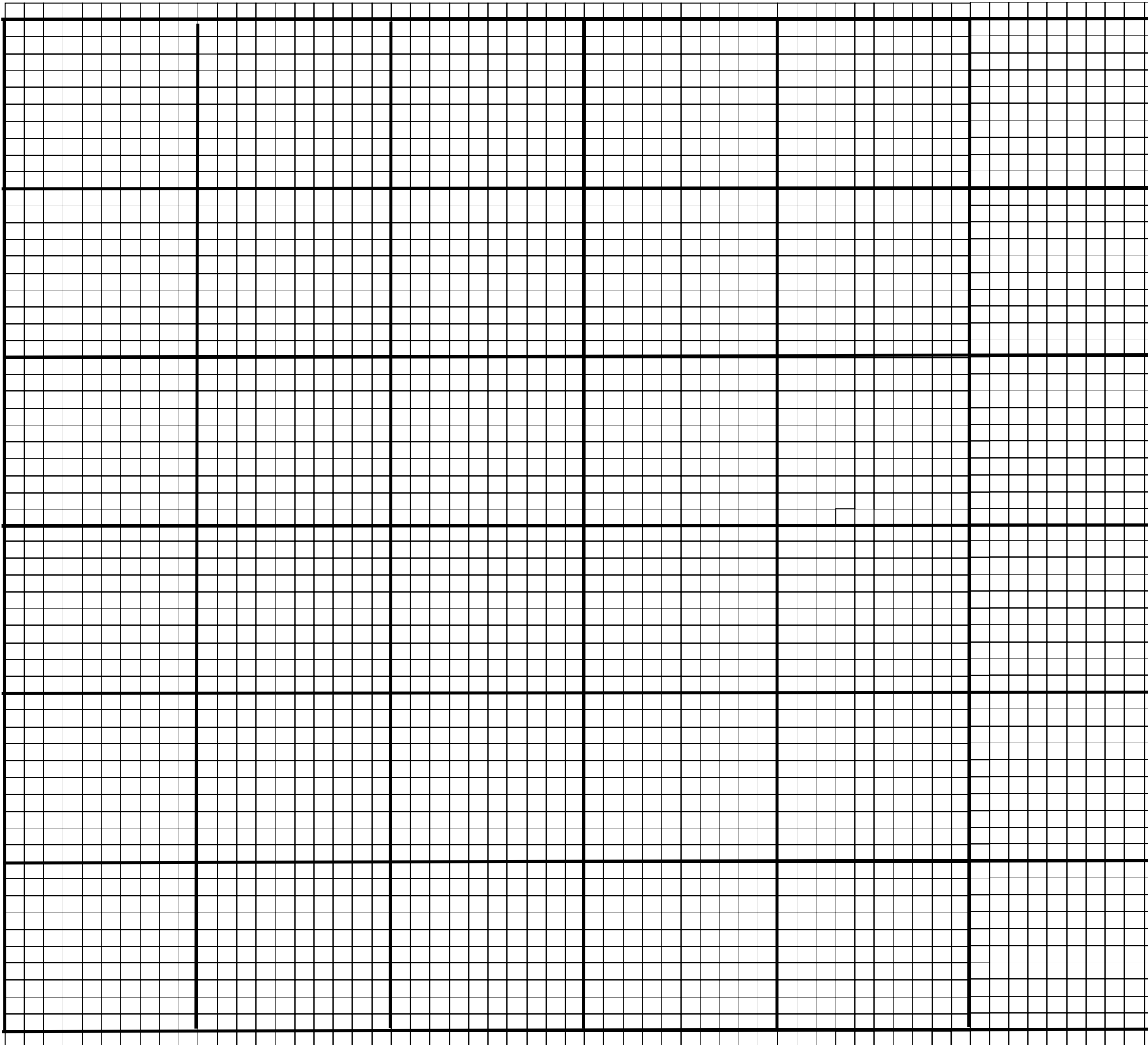

**MINISTRY OF EDUCATION (KNEC COMPLIANT)**

24. The probabilities that a husband and wife will be a live 25 years from now are 0.7 and 0.9 respectively. Find the probability that in 25 years time;

a) Both will be a live (2mks)

b) Neither will be a live (3mks)

c) One will be a live (2mks)

d) At least one will be a live (3mks)

**MINISTRY OF EDUCATION (KNEC COMPLIANT)**

**NAME.....INDEX NO. ....**

**DATE: .....**

**SIGN: .....**

**121/1**

**MATHEMATICS ALT. A**

**PAPER 1**

**CLASS OF KCSE 2024**

**TIME: 2 ½ HOURS**

**THE COASTAL & EASTERN REGIONS KCSE**

**JOINT NATIONAL MOCK 2024**

***Kenya Certificate of Secondary education (K.C.S.E)***

**121/1**

**MATHEMATICS**

**PAPER 1**

**2 ½ HOURS**

**Instructions to Candidates**

1. Write your name, Admission number and class in the spaces provided.
2. Sign and write date of the examination in the spaces provided.
3. The paper contains TWO sections: Section I and II
4. Answer ALL questions in section I and **STRICTLY ANY FIVE** questions from section II.
5. All working and answers must be written on the question paper in the spaces provided below each question.
6. Show all the steps in your calculations, giving your answers at each stage in the spaces below each question.
7. Marks may be awarded for correct working even if the answer is wrong.
8. Non-programmable silent electronic calculators and KNEC Mathematical tables may be used except where stated otherwise.

**For Examiner's use only**

**Section I**

1	2	3	4	5	6	7	8	9	10	11	12	13	14	15	16	TOTAL

**Section II**

17	18	19	20	21	22	23	24	25	TOTAL

**GRAND TOTAL**

--

**MINISTRY OF EDUCATION (KNEC COMPLIANT)**

Section I(50 Marks): Answer ALL questions in the section in the space provided.

1. Evaluate  $\frac{-12 \div (-3) \times 4 - (-20)}{-6 \times 6 \div +(-6)}$  (2 Marks)

2. Mr. Owino spends  $\frac{1}{4}$  of his salary on school fees. He spends  $\frac{2}{3}$  of the remainder on food and a fifth of what is left on transport. He saves the balance. In certain month he saved Sh. 3400. What was his salary? (3 marks)

3. Simplify: (3 Marks)

$$\frac{2y^2 - 3xy - 2x^2}{4y^2 - x^2}$$

4. Find x if  $3^{2x+3} + 1 = 28$  (2 Marks)



**MINISTRY OF EDUCATION (KNEC COMPLIANT)**

5. The circle below whose area is  $18.05\text{cm}^2$  circumscribes triangle ABC where  $AB = 6.3\text{cm}$ ,  $BC = 5.7\text{cm}$  and  $AC = 4.2\text{cm}$ . Find the area of the shaded part. (4 Marks)

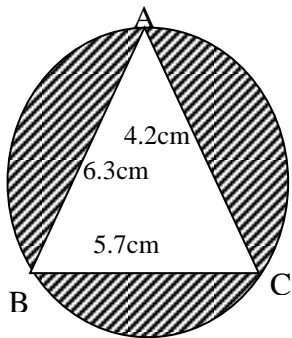

6. A salesman gets a commission of 2.4% on sales up to Sh. 100,000. He gets additional commission of 1.5% on sales above this. Calculate the commission he gets for sales worth Sh. 280,000. (3 Marks)

7. A rectangle whose area is  $96\text{m}^2$  is such that its length is 4metres longer than its width.  
Find

**MINISTRY OF EDUCATION (KNEC COMPLIANT)**

(a) Its dimensions  
(2 Marks)

(b) Its perimeter  
(1 Mark)

8. Give  $\sin(90 - a) = \frac{1}{2}$  find without using trigonometric tables the value of  $\cos a$  .  
(2 Marks)

9. In triangle ABC below,  $AC = BC$ , AB is parallel to DE,  $AB = 15\text{cm}$ ,  $DE = 7.5\text{cm}$  and  $BE = 6\text{cm}$ .

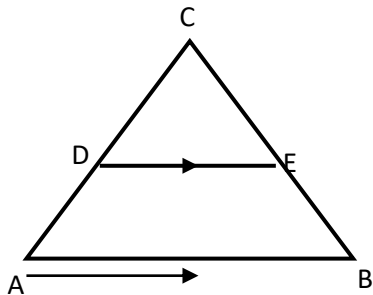

Calculate

**MINISTRY OF EDUCATION (KNEC COMPLIANT)**

(a) Length CE  
(2 Marks)

(b) Area of quadrilateral ABED.  
(2 Marks)

10. A measuring cylinder of base radius 5cm contains water whose level reads 6cm high. A spherical object is immersed in the water and the new level reads 10cm. Calculate the radius of the spherical object (3 Marks)

**MINISTRY OF EDUCATION (KNEC COMPLIANT)**

11. Using a ruler and pair of compasses only, construct triangle ABC in which  $AB = 6\text{cm}$ ,  $BC = 8\text{cm}$  and angle  $ABC = 45^\circ$ . Drop a perpendicular from A to BC to meet line BC at M. Measure AM and AC. (4 Marks)

12. In a book store, books packed in cartons are arranged in rows such that there are 50 cartons in the first row, 48 cartons in the next row, 46 in the next and so on.

(a) How many cartons will there be in the 8<sup>th</sup> row? (2 Marks)

(b) If there are 20 rows in total, find the total number of cartons in the book store. (2 Marks)

**MINISTRY OF EDUCATION (KNEC COMPLIANT)**

13. Draw the net of the solid below and calculate the total surface area of its faces.

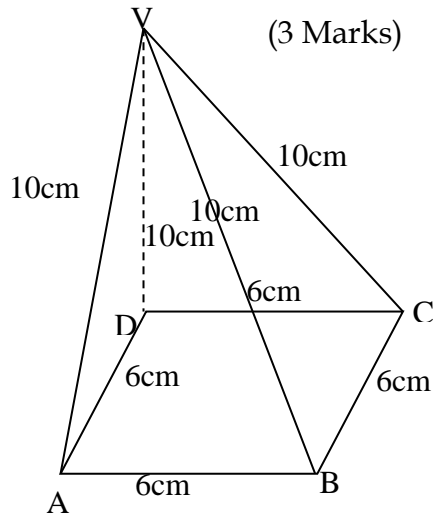

14. Town X is 20km in a bearing of  $060^{\circ}$  from Y, and Z is 30km in the direction  $150^{\circ}$  from Y. Using the scale 1cm represents 5km, find by scale drawing:

- (a) the bearing of Y from Z. (2 Marks)
- (b) the distance of X from Z. (2 Marks)

**MINISTRY OF EDUCATION (KNEC COMPLIANT)**

15. Solve for x in  $2^{2x} - 18 \times 2^x = 40$   
(3 Marks)

16. Oketch sells his car to Jane and makes a profit of 20%. Jane sells the same to Issa at Sh.180, 000, making a loss of 10%. Determine the price at which Oketch bought the car.  
(3 Marks)

**MINISTRY OF EDUCATION (KNEC COMPLIANT)**

**Section II (50 Marks):**

**Answer ANY five questions in this section in the spaces provided.**

17. The distance between towns A and B is 360km. A minibus left town A at 8.15 a.m. and traveled towards town B at an average speed of 90km/hr. A matatu left town B two and a third hours later on the same day and travelled towards A at average speed of 110km/hr.

(a) (i) At what time did the two vehicles meet? (4 Marks)

(ii) How far from A did the two vehicles meet? (2 Marks)

(b) A motorist started from his home at 10.30 a.m. on the same day as the matatu and travelled at an average speed of 100km/h. He arrive at B at the same time as the minibus. Calculate the distance from A to his house. (4 Marks)

18. Karis owns a farm that is triangular in shape as shown below.

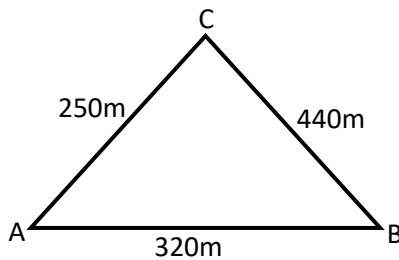

(a) Calculate the size of angle BAC  
(2 Marks)

(b) Find the area of the farm in hectares  
(3 Marks)

(c) Karis wishes to irrigate his farm using a sprinkler machine situated in the farm such that it is equidistant from points A, B and C.  
(i) Calculate the distance of the sprinkler from point C.  
(2 Marks)



- (ii) The sprinkler rotates in a circular motion so that the maximum point reached by the water jets is the vertices A, B and C. Calculate the area outside his farm that will be irrigated. (3 Marks)

19. A ship leaves port M and sails on a bearing of  $050^{\circ}$  heading towards island L. Two Navy destroyers sail from a naval base N to intercept the ship. Destroyer A sails such that it covers the shortest distance possible. Destroyer B sails on a bearing of  $20^{\circ}$  to L. The bearing of N from M is  $100^{\circ}$  and distance  $NM = 300\text{KM}$ . Using a scale of 1cm to represent 50km, determine:-

- (i) the positions of M, N and L.

(3 Marks)

- (ii) the distance travelled by destroyer A

(3 Marks)

- (iii) the distance travelled by destroyer B.

(2 Marks)

**MINISTRY OF EDUCATION (KNEC COMPLIANT)**

(iv) the bearing of N from L.  
(2 Marks)

20. A number of people agreed to contribute equally to buy books worth KSh. 1200 for a school library. Five people pulled out and so the others agreed to contribute an extra Shs. 10 each. Their contributions enabled them to buy books worth Shs. 200 more than they originally expected.

(a) If the original numbers of people was  $x$ , write an expression of how much each was originally to contribute. (1 Mark)

(b) Write down two expressions of how much each contributed after the five people pulled out. (2 Marks)

(c) Calculate the number of people who made the contribution. (5 Marks)

(d) Calculate how much each contributed.  
(2 Marks)

21. Using a ruler and a pair of compasses only, draw a parallelogram ABCD, such that angle DAB =  $75^\circ$ . Length AB = 6.0cm and BC = 4.0cm. From point D, drop a perpendicular to meet line AB at N.

(7 Marks)

(i) Measure length DN  
(1 Mark)

(ii) Find the area of the parallelogram.  
(2 Marks)

**MINISTRY OF EDUCATION (KNEC COMPLIANT)**

22. The following measurements were recorded in a field book of a farm in metres (xy = 400m)

	Y	
	400	
C60	340	
	300	120D
	240	100E
	220	160F
B100	140	
A120	80	
	x	

(a) Using a scale of 1cm representing 4000cm, draw an accurate map of the farm.  
(3 Marks)

**MINISTRY OF EDUCATION (KNEC COMPLIANT)**

(b) If the farm is on sale at Kshs. 80,000.00 per hectare, find how much it costs.  
(7 Marks)

23. The table shows marks obtained by 100 candidates at Goseta Secondary School in Biology examination.

Marks	15-24	25-34	35-44	45-54	55-64	65-74	75-84	85-94
Frequency	6	14	24	14	x	10	6	4

(a) Determine the value of x  
(2 Marks)

(b) State the modal class  
(1 Mark)

(c) Calculate the median mark  
(2 Marks)

(d) Calculate the mean mark  
(5 Marks)

24. In the diagram below, two circles, centres A and C and radii 7cm and 24cm respectively intersect at B and D.  $AC = 25\text{cm}$ .

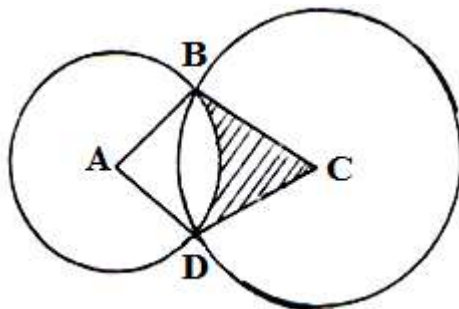

**MINISTRY OF EDUCATION (KNEC COMPLIANT)**

(a) Show that angle  $ABC = 90^\circ$ .

(3 Marks)

(b) Calculate

(i) the size of obtuse angle  $BAD$

(3 Marks)

(ii) the area of the shaded part

(4 Marks)



**MINISTRY OF EDUCATION (KNEC COMPLIANT)**

**NAME.....INDEX NO. ....**

**DATE: .....**

**SIGN: .....**

**121/2**

**MATHEMATICS ALT. A**

**PAPER 2**

**CLASS OF KCSE 2024**

**TIME: 2 ½ HOURS**

**THE COASTAL & EASTERN REGIONS KCSE**

**JOINT NATIONAL MOCK 2024**

***Kenya Certificate of Secondary education (K.C.S.E)***

**121/2**

**MATHEMATICS**

**PAPER 2**

**2 ½ HOURS**

**Instructions to Candidates**

1. Write your name, Admission number and class in the spaces provided.
2. Sign and write date of the examination in the spaces provided.
3. The paper contains TWO sections: Section I and II
4. Answer ALL questions in section I and **STRICTLY ANY FIVE** questions from section II.
5. All working and answers must be written on the question paper in the spaces provided below each question.
6. Show all the steps in your calculations, giving your answers at each stage in the spaces below each question.
7. Marks may be awarded for correct working even if the answer is wrong.
8. Non-programmable silent electronic calculators and KNEC Mathematical tables may be used except where stated otherwise.

**For Examiner's use only**

**Section I**

1	2	3	4	5	6	7	8	9	10	11	12	13	14	15	16	TOTAL

**GRAND TOTAL**

**Section II**

17	18	19	20	21	22	23	24	25	TOTAL

--

**MINISTRY OF EDUCATION (KNEC COMPLIANT)**

Section I(50 Marks): Answer ALL questions in the section in the space provided.

**SECTION I**

1. Use logarithm tables correct to 4 significant figures to evaluate.

(3 Marks)

$$\frac{\sqrt[3]{0.07214 \times 2.037}}{69.8}$$

2. Find the equation of the perpendicular bisector of line PQ where the co-ordinates of P and Q are P (-2, 8) and Q (4, 7).

(3 Marks)

3. The surface areas of two spheres are  $36\text{cm}^2$  and  $49\text{cm}^2$ . If the volume of the smaller sphere is  $20.2\text{cm}^3$ , calculate the volume of the larger one.

(2 Marks)

**MINISTRY OF EDUCATION (KNEC COMPLIANT)**

4. The marked price of a shirt is Sh. 800. A customer buys the shirt after being given a discount of 13%. The seller then realizes that he made a profit of 20% on this sale. Find how much the seller had bought the shirt.

(2 Marks)

5. In the grid provided below, show the region R that is satisfied by the three inequalities given below.

$$Y \leq 6 - x$$

$$y < x + 4$$

$$y \geq 2$$

(4 Marks)

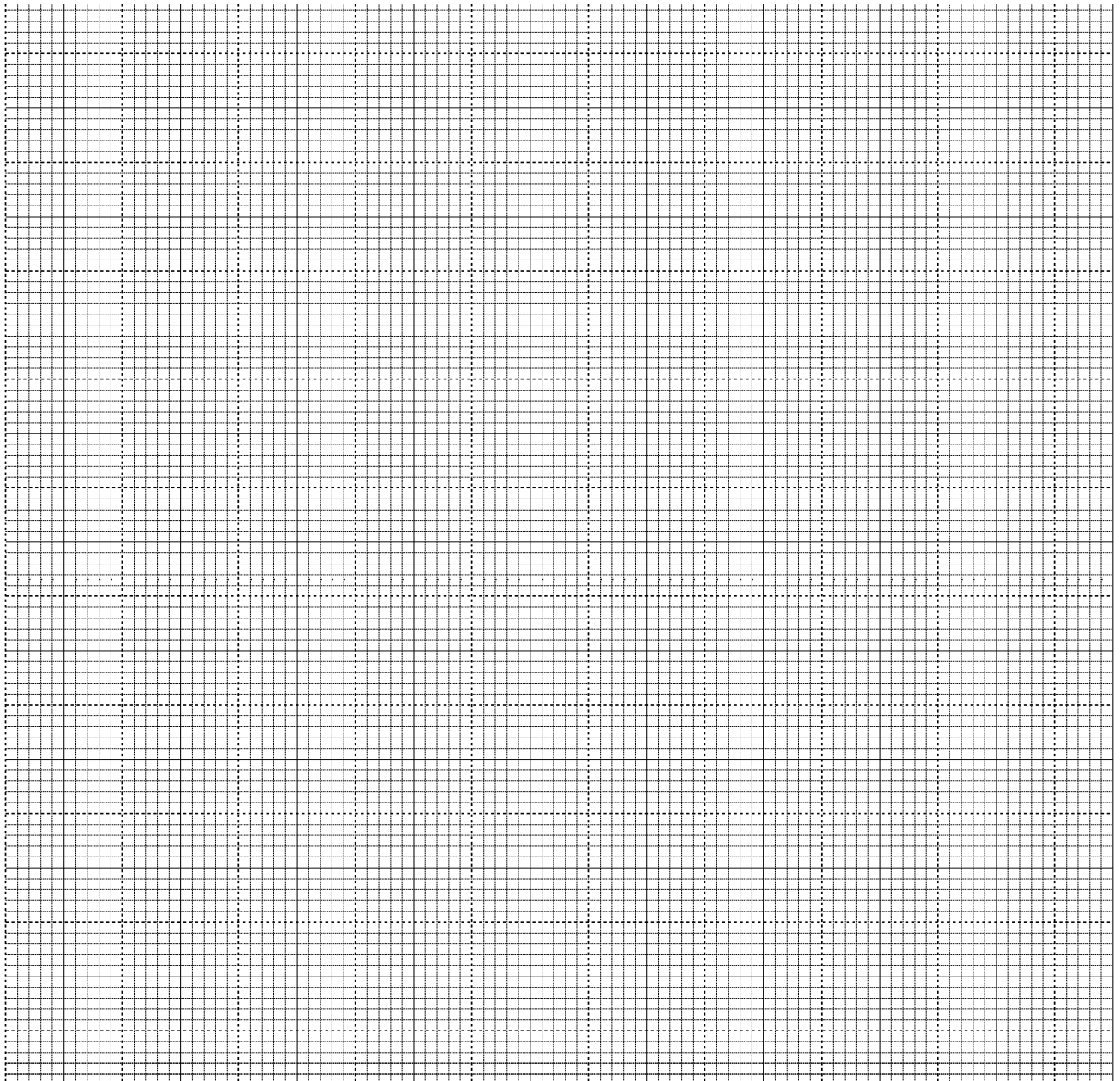

6. The radius of a cone increases in the ratio 4:3 while it's height decreases in the ratio 3:4. Determine the percentage change in the volume of the cone.  
(3 Marks)

7. Solve for x in the equation

(3 Marks)

$$\text{Log } (5x + 75) - 2 \text{ Log } 3 = \text{Log } (2x - 9)$$

8. Given that  $\vec{a} = 3\vec{i} - 2\vec{j} + 3\vec{k}$  and  $\vec{b} = 2\vec{i} - 4\vec{j} - 3\vec{k}$  where  $\vec{i}$ ,  $\vec{j}$  and  $\vec{k}$  are unit vectors, find  $|\vec{2a} + 3\vec{b}|$  (3 Marks)

**MINISTRY OF EDUCATION (KNEC COMPLIANT)**

9. Make  $x$  the subject of the formula in

$$a = \left( \frac{bx}{b+x} \right)^{\frac{1}{3}}$$

Hence find the value of  $x$  when  $a = 2$  and  $b = 6$ .

(4 Marks)

10. In the figure below,  $BT$  is a tangent to the circle at  $B$ .  $AXCT$  and  $BXD$  are straight

lines.  $AX = 6\text{cm}$ ,

$CT = 8\text{cm}$ ,  $BX = 4.8\text{cm}$  and  $XD = 5\text{cm}$ . (Figure not drawn to scale)

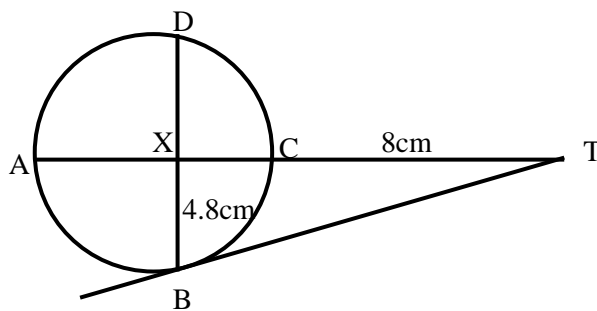

Find the length of

(a)  $XC$

(2 Marks)

(b)  $BT$

(2 Marks)

**MINISTRY OF EDUCATION (KNEC COMPLIANT)**

11. Simplify  $\frac{3}{\sqrt{5}-2} + \frac{1}{\sqrt{5}}$  leaving your answer in the form  $a + b\sqrt{c}$ , where  $a$ ,  $b$  and  $c$  are rational numbers.

(3 Marks)

12. A quantity  $y$  varies partly as another quantity  $x$  and partly as the square of  $x$ . When  $x = 20$ ,  $y = 45$  and when  $x = 24$ ,  $y = 60$ .

(a) Express  $y$  in terms of  $x$

(3 Marks)

(b) Find  $x$  when  $y = 75$

(1 Mark)

13. Expand  $(a - x)^6$  upto the term in  $(x)^3$ . Use your expansion to estimate the value of  $(2.99)^6$  to 3 decimal places.

(4 Marks)

**MINISTRY OF EDUCATION (KNEC COMPLIANT)**

14. A pipe 3.0m long was cut into three pieces. The first piece and the second one were measured as 1.3m and 0.94m respectively. Find the limits within which the length of the third piece lies. (3 Marks)

15. A coffee blender has two brands of coffee, Tamu and Chungu. A kilogram of Tamu costs Sh. 70 while a kilogram of Chungu costs Shs. 64. In what ratio should he mix the two brands to make a blend which costs Shs. 68 per kilogram?  
(2 Marks)

16. Find the centre and radius of a circle whose equation is  $x^2 + y^2 + 8x + y^2 - 2y - 1 = 0$   
(3 Marks)



**MINISTRY OF EDUCATION (KNEC COMPLIANT)**

**SECTION II (50 Marks): Answer ANY FIVE questions in this section in the spaces provided.**

17. In a Science class  $\frac{2}{3}$  of the class are boys and the rest are girls. 80% of the boys and 90% of the girls are right handed. The probability that the right handed student will break a test tube in any session is  $\frac{1}{10}$  and that for the left handed student is  $\frac{3}{10}$ , regardless of whether boy or girl.

(a) Draw a tree diagram to represent this information.

(2 Marks)

(b) Using the tree diagram drawn, find the probability that:

(i) A student chosen at random from the class is left handed

(2 Marks)

(ii) A test tube is broken by a left handed student.

(2 Marks)

**MINISTRY OF EDUCATION (KNEC COMPLIANT)**

(iii) A test tube is broken by a right handed student.

(2 Marks)

(iv) A test tube is not broken in any session

(3 Marks)

18. Matrix P is given by  $\begin{pmatrix} 4 & 7 \\ 5 & 8 \end{pmatrix}$

(a) Find  $P^{-1}$

(2 Marks)

(b) Two institutions, Katulani High School and Nthia High School purchased beans at Sh. b per bag and maize at Sh. m per bag. Katulani purchased 8 bags of beans and 14 bags of maize for KSh. 47,600. Nthia purchased 10 bags of beans and 16 bags of maize for KSh. 57,400.

(i) Form a matrix equation to represent the information above.

(2 Marks)

**MINISTRY OF EDUCATION (KNEC COMPLIANT)**

(ii) Use matrix  $P^{-1}$  to find the prices of one bag of each item.

(3 Marks)

(c) The price of beans later went up by 5% and that of maize remained constant. Katulani bought the same quality of beans but spent the same total of money as before on the two items. State the new ratio of beans to maize.

(3 Marks)

**MINISTRY OF EDUCATION (KNEC COMPLIANT)**

19. James' earning are as follows:-

Basic salary Sh. 38,000 p.m

House allowance Sh. 14,000 p.m

Travelling allowance Sh. 8,500 p.m

Medical allowance Sh. 3,300

The table for the taxable income is as shown below.

Income tax in K£ p.a	Tax in Sh. per pound
1—————600	2
6001————12000	3
18000	
12001————24000	4
1001————30000	5
36000	
24001————42000	6
30001————48000	7
36001————	8
42001————	9
Over	10
48000	

(a) Calculate James' taxable income in K£ p.a.

(2 Marks)

**MINISTRY OF EDUCATION (KNEC COMPLIANT)**

(b) Calculate James's P.A.YE if he is entitled to a tax relief of Sh. 18000 p.a.

(4 Marks)

(c) James is also deducted the following per month:-

NHIF	Sh. 320
Pension scheme	Sh. 1000
Co-operative shares	Sh. 2000
Loan repayment	Sh. 5000
Interest on loan	Sh. 500

(i) Calculate James' total deduction per month in KSh.

(2 Marks)

**MINISTRY OF EDUCATION (KNEC COMPLIANT)**

(ii) Calculate his net salary per month

(2 Marks)

20. Three consecutive terms of a geometric progression are  $3^{2x+1}$ ,  $9^x$  and 81 respectively.

(a) Calculate the value of x

(3 Marks)

(b) Find the common ratio of the series.

(1 Mark)

**MINISTRY OF EDUCATION (KNEC COMPLIANT)**

(c) Calculate the sum of the first 4 terms of this series.

(3 Marks)

(d) Given that the fifth and the seventh terms of the G.P form the first two consecutive terms of an arithmetic sequence, calculate the sum of the first 20 terms of the sequence. (3 Marks)

**MINISTRY OF EDUCATION (KNEC COMPLIANT)**

21. A tank has two inlet taps P and Q and an outlet tap R. When empty, the tank can be filled by tap P alone in  $4\frac{1}{2}$  hour or by tap Q alone in 3 hours. When full, the tap can be emptied in 2 hours by tap R.

(a) The tank is initially empty. Find how long it would take to fill up the tank

(i) If tap R is closed and taps P and Q are opened at the same time.

(2 Marks)

(ii) If all the three taps are opened at the same time.

(2 Marks)

(b) The tank is initially empty and the three taps are opened as follows:-

P at 8.00 a.m.

Q at 8.45 a.m

R at 9.00 a.m

(i) Find the fraction of the tank that would be filled by 9.00 a.m

(3 Marks)



**MINISTRY OF EDUCATION (KNEC COMPLIANT)**

- (ii) Find the time the tank would be fully filled up  
(3 Marks)

22. In the figure below M and N are points on OQ and QP such that  $OM:MQ = 2:3$  and  $QN:NP = 2:1$ . ON and PM intersect at X.

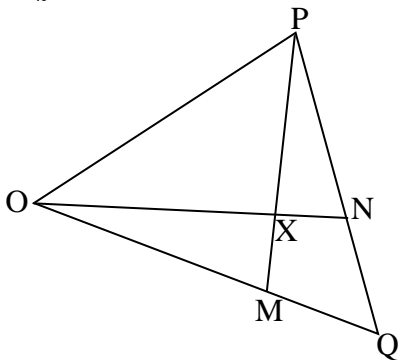

- (a) Given that  $OP = p$  and  $OQ = q$ . Express in terms of p and q

(i) ON

(2 Marks)

(ii) PM

(2 Marks)

**MINISTRY OF EDUCATION (KNEC COMPLIANT)**

(b) Given that  $\vec{OX} = h\vec{ON}$  and  $\vec{PX} = k\vec{PM}$  where  $h$  and  $k$  are scalars,

(i) Determine the values of  $h$  and  $k$ .

(5 Marks)

(ii) Determine ratio in which  $X$  divides  $PM$ .

(1 Mark)

23. The figure below shows a circle centre  $O$ ,  $PQRS$  is a cyclic quadrilateral and  $QOS$

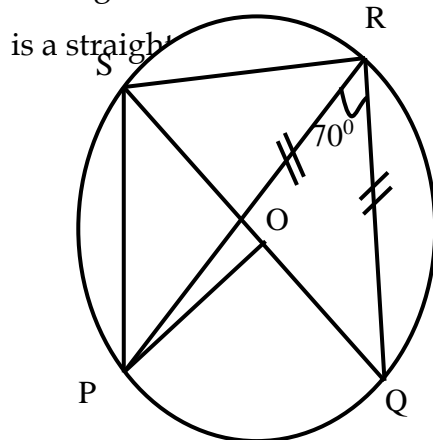

**MINISTRY OF EDUCATION (KNEC COMPLIANT)**

Giving reasons for your answers, find the size of

(a) Angle PRS

(2 Marks)

(b) Angle POQ

(2 Marks)

(c) Angle QSR

(3 Marks)

(d) Reflex angle POS

(3 Marks)

**MINISTRY OF EDUCATION (KNEC COMPLIANT)**

24. (a) Complete the table below for  $y = x^3 + 4x^2 - 5x - 5$

(2 Marks)

x	-5	-4	-3	-2	-1	0	1	2
$y = x^3 + 4x^2 - 5x - 5$			19			-5		

(c) On the grid provided, draw the graph of  $y = x^3 + 4x^2 - 5x - 5$  for  $-5 \leq x \leq 2$

(3 Marks)

**MINISTRY OF EDUCATION (KNEC COMPLIANT)**

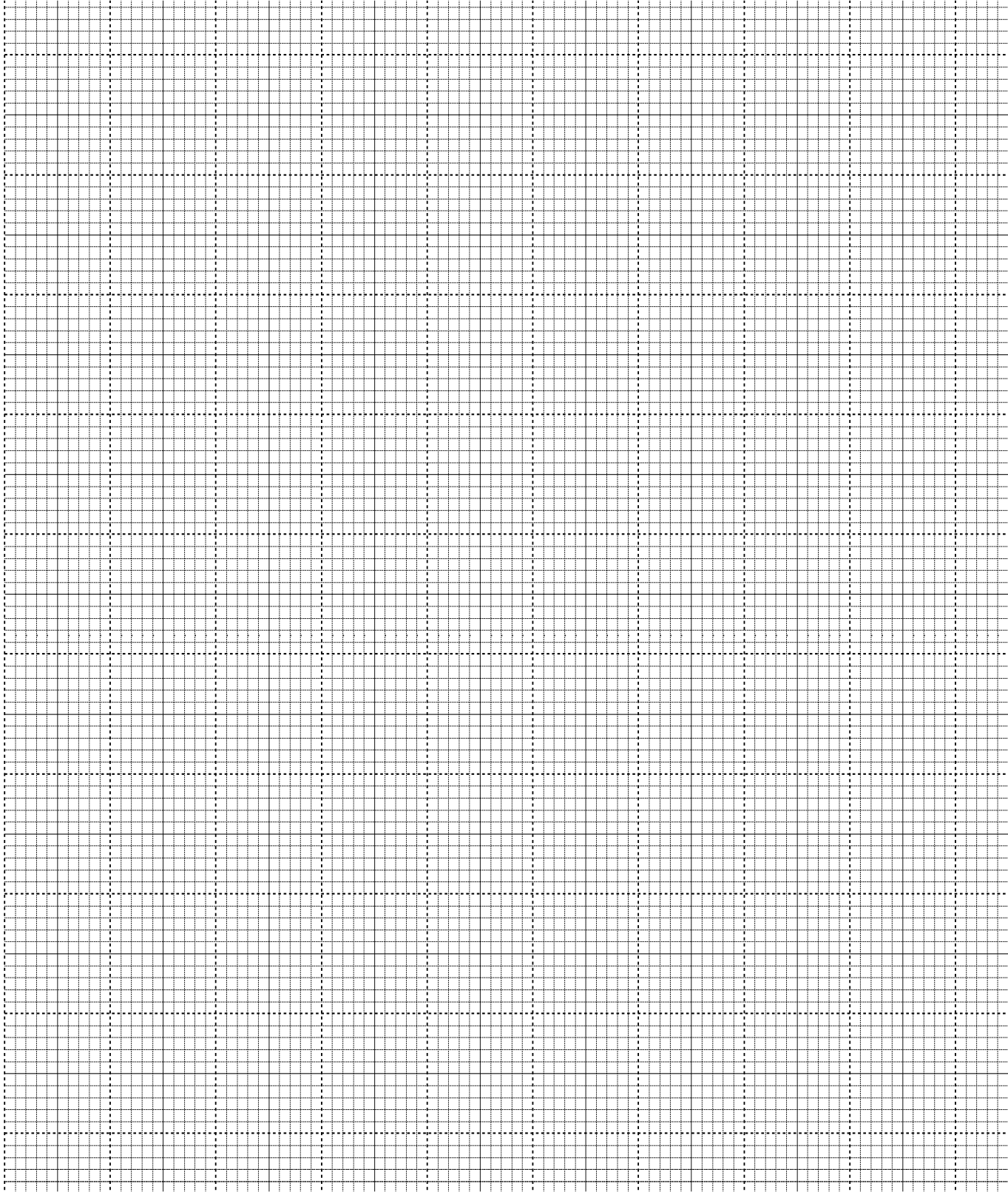

**MINISTRY OF EDUCATION (KNEC COMPLIANT)**

(d) (i) Use the graph to solve the equation  $x^3 + 4x^2 - 5x - 5 = 0$

(2 Marks)

(ii) By drawing a suitable straight line on the graph, solve the equation

(3 Marks)

$$x^3 + 4x^2 - 5x - 5 = -4x - 1$$

**MINISTRY OF EDUCATION (KNEC COMPLIANT)**

Name: ..... Adm NO:.....

School: .....Candidate's signature: .....

Class/Stream .....Date: .....

121/1  
MATHEMATICS  
PAPER 1  
CLASS OF KCSE 2024  
2 ½ HOURS

**THE RIFT VALLEY & NORTH EASTERN REGIONS**  
**KCSE JOINT NATIONAL MOCK 2024**  
Kenya Certificate of Secondary Education

**INSTRUCTIONS TO CANDIDATES**

1. Write your name school and admission number in the spaces provided at the top of this space
2. The paper consists of two sections section I and section II
3. Answer all the questions in section I and only five questions from section II
4. All answers and working must be written on the question paper in the spaces provided below each question
5. Marks may be given for correct working even if the answer is wrong.
6. Negligence and slovenly work will be penalized
7. Non- programmable silent electronic calculators or a mathematical table may be used except where stated otherwise.

**FOR EXAMINERS ONLY**

**SECTION 1**

1	2	3	4	5	6	7	8	9	10	11	12	13	14	15	16	TOTAL

**SECTION II**

17	18	19	20	21	22	23	24	TOTAL

GRAND TOTAL

**MINISTRY OF EDUCATION (KNEC COMPLIANT)**

**SECTION 1**

1. Without using calculators or mathematical tables, evaluate leaving your answer in standard form.

(3mks)

$$\frac{1.33 \times 0.51}{0.19 \times 0.0017}$$

2. Three bells are programmed to ring after an interval of 15 minutes, 25 minutes and 50 minutes. If they all rang together at 6.45am, when will they next ring together? (3mks)

3. The volumes of two similar solid cylinders are  $1920\text{cm}^3$  and  $810\text{cm}^3$ . If the area of the curved surface of the smaller cylinder is  $300\text{cm}^2$ , find the area of the curved surface of the larger cylinder. (4mks)



**MINISTRY OF EDUCATION (KNEC COMPLIANT)**

4. Solve for  $x$  in the equation

(3mks)

$$(3^{2x})^3 = 81 \times 9^4$$

5. Class of 30 students uses 75 pencils in a term. If the number of students is reduced to 24, how many pencils are likely to be used in a term?

(2mks)

6. An empty 300ml bottle has a mass of 270g. Calculate the mass of the bottle when it is full of a liquid whose density is  $1.1\text{g/cm}^3$ .

(3mks)

7. Simplify

$$\frac{4x-20}{5-x}$$

(3mks)

**MINISTRY OF EDUCATION (KNEC COMPLIANT)**

8. The shaded region in the figure below shows a section of a road on a roundabout. Calculate the area in  $\text{cm}^2$ . (use  $\pi = 3.142$ )  
(3mks)



9. Solve the inequalities and represent your solution on a single number line.

$$x - 5 \leq 3x - 8 < 2x - 3 \quad (3\text{mks})$$

10. Tourists visits Kenya and changes \$400 to ksh. At the end of the holiday, she has only ksh. 1450 left. How many dollars did she spend in the holiday if the exchange rate is as per the table below.

Currency	Buying ksh	Selling Ksh
1US dollar \$	79.25	81.50

(3mks)

**MINISTRY OF EDUCATION (KNEC COMPLIANT)**

11. Use tables of squares, square root and reciprocal only to evaluate.

(4mks)

$$(0.06458)^{\frac{1}{2}} + \left(\frac{2}{0.4327}\right)^2$$

12. Every week, the age of people who attend a cinema is recorded. In a particular week the data was as shown in the table below.

Age (year) ( $x$ )	$0 \leq x < 5$	$5 \leq x < 15$	$15 \leq x < 25$	$25 \leq x < 45$	$45 \leq x < 75$
No of people	14	41	59	70	15

On the grid provided, draw a histogram to represent the distribution.

Scale: 1cm to represent 5 units on horizontal axis

2cm to represent 2 units on vertical axis.

(4mks)

13. If  $\mathbf{p} = \begin{pmatrix} 3 \\ 4 \end{pmatrix}$ ,  $\mathbf{q} = \begin{pmatrix} -2 \\ 1 \end{pmatrix}$  and  $\mathbf{c} = \begin{pmatrix} 13 \\ 21 \end{pmatrix}$  Find the scalar  $m$  to satisfy the equation  $5\mathbf{p} + m\mathbf{q} = \mathbf{c}$  (3mks)

14. Find the sum of interior angles of a regular polygon with 18 sides.  
(2mks)

**MINISTRY OF EDUCATION (KNEC COMPLIANT)**

15. In the figure below, O is the centre of the circle. Chords AB and CD intersect at X. Given that CX = 8cm, XD = 5cm and XB = 4cm, calculate the length of AX and hence find the radius of the circle.

(3mks)

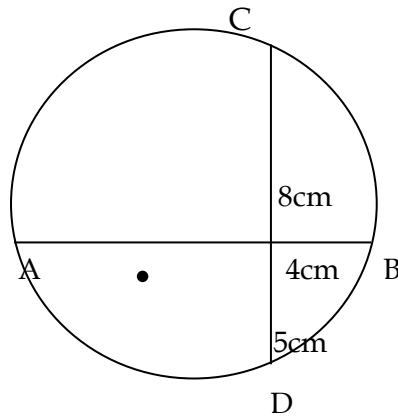

16. Use logarithm tables to evaluate

$$\sqrt[3]{\frac{1.42 \times 0.004623}{\log 4}}$$

(4mks)

**SECTION II**

**Answer any five questions only**

17. A sales lady dealing in shoes earn a basic salary of shs 30,000. In addition she is paid commission on the sales of shoes as follows.

	Commission
For sales up to shs 100,000	0%
For sales above shs 100,000	
(i) For first 50,000	4%
(ii) For next 50,000	5%
Any amount above 200,000	10%

On a certain month she sold 200 pair of shoes marked at shs 1200 a pair at a discount of 5%.

(a) Calculate the total sales for the month.  
(2mks)

(b) Calculate her total earning for that month.  
(4mks)

**MINISTRY OF EDUCATION (KNEC COMPLIANT)**

(c) If the next month her basic salary was increased by 10%. If she earned a total of sh. 39,160: Determine

(i) Her total sales for the month.

(2mks)

(ii) The number of pairs of shoes she sold that month.

(2mks)

18. The vertices of the triangle shown below are

A(2,0), B(5,3) and C(5,1)

(a) Find the coordinates of triangle  $A^I B^I C^I$  the image of triangle ABC after a

transformation by the matrix  $T = \begin{pmatrix} -1/2 & 3/2 \\ 3/2 & -1/2 \end{pmatrix}$

(2mks)

(b) Find the coordinates of triangle  $A^{II} B^{II} C^{II}$ , the image of triangle  $A^I B^I C^I$

after a transformation by the matrix  $S = \begin{pmatrix} 2 & 1 \\ 1 & 0 \end{pmatrix}$

(2mks)

**MINISTRY OF EDUCATION (KNEC COMPLIANT)**

(c) Draw both triangle  $A^I B^I C^I$  and triangle  $A^{II} B^{II} C^{II}$  on the same grid as triangle ABC.

(2mks)

(d) Determine the single matrix that can map triangle  $A^{II} B^{II} C^{II}$  on to triangle ABC (4mks)

19. (a) using a ruler and a pair of compasses only, construct triangle PQR in which  $QR = 1.5\text{CM}$ ,  $PR = 2.2\text{cm}$  and angle  $PRQ = 120^\circ$

(3mks)



(b) Measure PQ and angle PQR  
(2mks)

(c) Construct the perpendicular bisector QR and PR  
(2mks)

(d) Draw the circumscribed circle of triangle PQR  
(2mks)

(e) Measure the radius of the circle.  
(1mk)

**MINISTRY OF EDUCATION (KNEC COMPLIANT)**

20. In the figure below PQR and QUV are straight lines. QS are parallel to TV.  
Angles  $SQR = 40^\circ$  and  $TQV = 55^\circ$

O - is the centre of circle

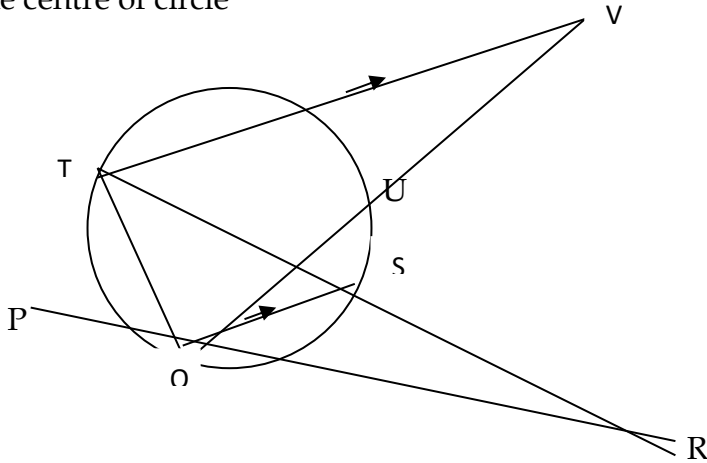

(a) Find the following angles giving reasons in each case

(i)  $\angle QTS$   
(2mks)

(ii)  $\angle QRS$   
(2mks)

(iii)  $\angle QVT$   
(2mks)

(iv)  $\angle QUT$   
(2mks)

**MINISTRY OF EDUCATION (KNEC COMPLIANT)**

(b) Given that  $QR = 8\text{cm}$  and  $SR = 4\text{cm}$ , find the radius of the circle.  
(2mks)

21. Two towns A and B are 80km apart. James started cycling from Town A to town B at 10.00am at an average speed of  $40\text{km hr}^{-1}$ . Mutuku started his journey from town B to A at 10.30am and travelled by car at an average speed of  $60\text{kmhr}^{-1}$ .

(a) Calculate

(i) The distance from A when James and Mutuku met.

(5mks)

(ii) Time of the day when the two met.

(2mks)

**MINISTRY OF EDUCATION (KNEC COMPLIANT)**

- (b) Kimeli started cycling from town A to town B at 10.21 am. He met Mutuku at the same time as James did. Determine Kimeli's average speed.  
(3mks)

22. A straight line  $L_1$  whose equation is  $3y - 2x = -2$  meets the  $x$  - axis at R

- (a) Determine the coordinates of R.  
(2mks)

(b) A second line  $L_2$  is perpendicular to  $L_1$  at R. Find the equation of  $L_2$  in the form

$y = mx+c$  where  $m$  and  $c$  are constants.  
(3mks)

- (c) A third line  $L_3$  passing through  $(-4, 1)$  is parallel to  $L_1$ . Find
- (i) The equation of  $L_3$  in the form  $y=mx+c$  where  $m$  and  $c$  are constants.  
(2mks)
- (ii) the coordinates of points  $S$  at which  $L_3$  intersects  $L_2$   
(3mks)

**MINISTRY OF EDUCATION (KNEC COMPLIANT)**

23. (a) complete the table below for the function

$$Y = x^3 + 4x^2 + 7x + 6 \text{ (give y values correct to 1dp)}$$

(2mks)

X	-4.5	-4	-3.5	-3	-2.5	-2	-1.5	-1	-0.5	0	0.5	1.0	1.5	2
$X^3$	-91.1	-64	42.9	-27		-8		-1	-0.1	0	0.1	1	3.4	8
$4x^2$	81	64	49	36		16		4		0	1	4	9	16
$7x$	-31.5	-28	24.5	-21		-4		-7	3.5	0	3.5	7.5	10.5	14
6	6	6	6	6	6	6	6	6	6	6	6	6	6	6
Y	-35.6	-22.0	-22.4	-6.0		0.0		2.0	3.4	6	10.6	18.0		44

(b) Draw the graph of  $y = x^3 + 4x^2 + 7x + 6$  for  $-4.5 \leq x \leq 2$  on the grid provided below (using 1cm rep 0.5 on x- axis (1cm rep 5 on y- axis)

(3mks)

(c) Use your graph to solve the simultaneous equations

(3mks)

- i.  $y = x^3 + 4x^2 + 7x + 6$
- ii.  $y = 10x + 15$

(d) Find a cubic equation in  $x$  whose roots are the  $x$  values you found in c above.

(1mk)

(e) From your graph state the root of  $x^3 + 4x^2 + 7x + 6 = 0$

(1mk)

24. The diagram below shows a wooden solid consisting of a cylindrical part of radius 3.5cm and a conical part of radius 4.2cm.  $\left( use \pi = \frac{22}{7} \right)$

**MINISTRY OF EDUCATION (KNEC COMPLIANT)**

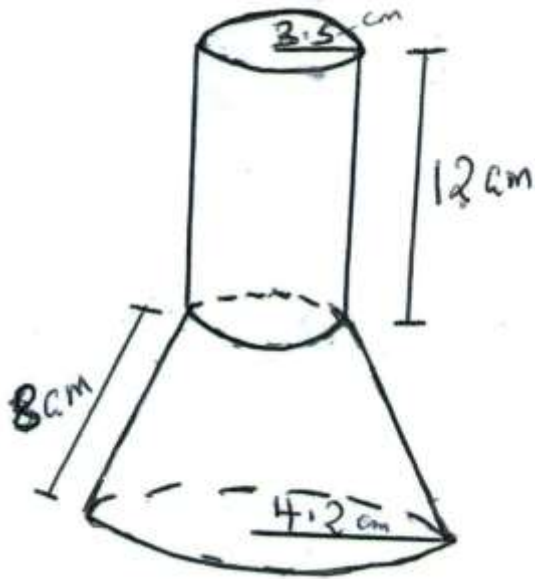

Find correct to two decimal places.

- (a) The surface area of the conical part.  
(5mks)

- (b) The volume of solid.  
(5mks)



**MINISTRY OF EDUCATION (KNEC COMPLIANT)**

Name: ..... Adm NO:.....

School: .....Candidate’s signature: .....

Class/Stream .....Date: .....

**121/2  
MATHEMATICS  
PAPER 2  
CLASS OF KCSE 2024  
2 ½ HOURS**

**THE RIFT VALLEY & NORTH EASTERN REGIONS**  
**KCSE JOINT NATIONAL MOCK 2024**  
**Kenya Certificate of Secondary Education**

**INSTRUCTIONS TO CANDIDATES**

- (a) Write your name and index number in the spaces provided above.
- (b) This paper consists of **TWO** sections. Section I and Section II.
- (c) Answer **ALL** the questions in section 1 and only **FIVE** questions from Section II
- (d) All answers and working must be written on the question paper in the spaces provided below each question.
- (e) Show all the steps in your calculations, giving your answers at each stage in the spaces below each question.
- (f) Marks may be given for correct working even if the answer is wrong.
- (g) Non- programmable silent calculators and **KNEC** mathematical tables may be used except where stated otherwise.
- (h) Candidates should check the question paper to ascertain that all the papers are printed as indicated and that no questions are missing.

**FOR EXAMINERS USE ONLY**

**SECTION I**

1	2	3	4	5	6	7	8	9	10	11	12	13	14	15	16

**Section II**

17	18	19	20	21	22	23	24	TOTAL

**GRAND TOTAL**

**MINISTRY OF EDUCATION (KNEC COMPLIANT)**

1. Solve the quadratic equation by completing the square method.

$$x^2 - 7x + 10 = 0$$

(3mks)

2. Simplify  $\frac{\sqrt{5}-\sqrt{3}}{\sqrt{5+\sqrt{3}}}$  by rationalizing the denominator.

(2mks)

3. Grade x rice costs shs 75 per kg and grade y rice costs shs 50 per kg. The two grades are mixed in the ratio such that the blend costs sh 70 per kg. Find the ratio in which grade x rice was mixed with grade y rice.

(3mks)

**MINISTRY OF EDUCATION (KNEC COMPLIANT)**

4. Given that  $A = \sqrt[4]{\frac{d-c^2g}{b+c^2f}}$  make c the subject of the formula.  
(3mks)

5. Solve the equation  $2 \sin (3x + 60) = 1$  for  $0^\circ \leq x \leq 180^\circ$   
(3mks)

6. (a) Expand and simplify  $(2 - x)^8$  up to 4<sup>th</sup> term.  
(2mks)

(b) Use the simplified expression in (a) above to estimate the value of  $(1.99)^8$  giving your answer correct to 4 significant figures.  
(2mks)

7. Solve the equation  $2 + \log_3 (2x - 7) = \log_3 (5x - 7)$  .  
(3mks)

8. (a) Construct a triangle ABC in which AB is 2.2cm, BC is 3.5cm and angle ABC is  $60^\circ$   
(2mks)

(b) A point D moves such that it is on the same side of BC as A. Construct the locus of D such that the area of  $\triangle ABC = \text{area of } \triangle BCD$ .

(2mks)

9. The equation of a circle is  $x^2 + y^2 - 6x + 8y - 11 = 0$ . Find the coordinates of the centre of the circle and its radius.

(3mks)

10. The length of a rectangle is 8.3 cm and its width is 5.45cm. Calculate

a) The relative error in area of the rectangle (3mks)

**MINISTRY OF EDUCATION (KNEC COMPLIANT)**

b) The percentage error in area  
(1mk)

11. A triangle  $xyz$  whose area is  $15.3\text{cm}^2$  mapped onto  $\Delta x^1y^1z^1$  by a transformation whose matrix is  $m = \begin{pmatrix} 3 & -2 \\ -1 & 2 \end{pmatrix}$ . Find the area of  $\Delta x^1y^1z^1$ .  
(3mks)

12. Solve the triangle (3mks)

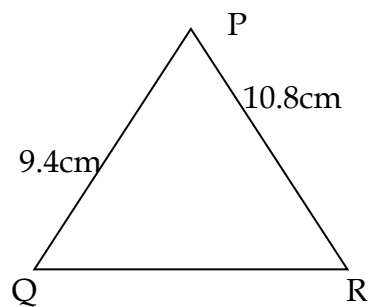

**MINISTRY OF EDUCATION (KNEC COMPLIANT)**

13. Fifteen men working at the rate of 9 hours per day take 20 days to complete a job. Find the number of days 27 men would take to complete the same job working at the rate of 10 hours a day. (3mks)

14. The 5<sup>th</sup> term of an arithmetic sequences is 71 and the 7<sup>th</sup> term is 59. Find  
(a) The first term and the common difference.  
(2mks)

(b) The 10<sup>th</sup> term  
(2mks)

15. Use matrix methods to solve the simultaneous equations.  
(3mks)

**MINISTRY OF EDUCATION (KNEC COMPLIANT)**

$$3x - 4y = 2$$

$$6x + y = 13$$

16. Factorise:  $2x^2 - x - 10$

(2mks)



**MINISTRY OF EDUCATION (KNEC COMPLIANT)**

**SECTION (II) (50MARKS)**

17. The following table shows the distribution of marks obtained by 50 students of a certain school.

Marks	45-49	50-54	55 - 59	60- 64	65 - 69	70-74	75- 79
No. of students	3	9	13	15	5	4	1

(a) State the modal class

(1mk)

(b) By using an assumed mean of 62, calculate

(i) The mean

(5mks)

(ii) The standard deviation

(4mks)

18. The figure below is a triangle  $OAB$ , where  $\vec{OA} = \mathbf{a}$  and  $\vec{OB} = \mathbf{b}$ . A point  $R$  divides  $AB$  in the ratio  $2:5$  and a point  $T$  divides  $OB$  in the ratio  $1:3$ .  $OR$  and  $AT$  intersect at  $D$ .

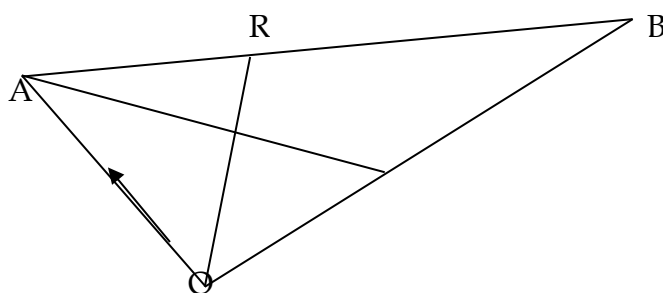

- a) Find in terms of  $\mathbf{a}$  and  $\mathbf{b}$
- i)  $\vec{BT}$  (1mk)
- ii)  $\vec{OR}$  (2mks)
- iii)  $\vec{AT}$  (1mk)

**MINISTRY OF EDUCATION (KNEC COMPLIANT)**

- b) Given that  $AD = kAT$  and  $RD = hRO$  where  $k$  and  $h$  are scalars. Find the values of  $k$  and  $h$ , hence express  $AD$  in terms of  $a$  and  $b$   
(5mks)

19. John travels to work by either boda-boda or by tuk-tuk. If he travel by tuk-tuk on every one day, there is a probability of 0.75 that he travels by a boda boda the following day. If he travels by a boda boda on any one day, then he travels by tuk-tuk the following day with a likelihood of  $\frac{5}{6}$ . There is a chance of  $\frac{2}{3}$  that he travels by tuk-tuk on Tuesday.

- a) Draw a tree diagram to illustrate the possible outcomes in 3 days.  
(2mks)

b) Find the probability that he travel by;

**MINISTRY OF EDUCATION (KNEC COMPLIANT)**

(i) Boda-boda on Wednesday  
(2mks)

(ii) Tuk-tuk on Wednesday  
(2mks)

(iii) Boda - boda on Thursday  
(3mks)

(iv) Tuk-tuk on Thursday  
(1mk)

20. (a) Fill the table below for the curves given by  $y = 3\sin(2x + 30^\circ)$  and  $y = \cos 2x$  for  $x$  value in the range  $0^\circ \leq x \leq 180^\circ$

(2mks)

X	$0^\circ$	$15^\circ$	$30^\circ$	$45^\circ$	$60^\circ$	$75^\circ$	$90^\circ$	$105^\circ$	$120^\circ$	$135^\circ$	$150^\circ$	$165^\circ$	$180^\circ$
$Y = 3 \sin(2x + 30)$	1.50			2.60						-2.60			1.50
$Y = \cos 2x$	1.00					-0.87			-0.50				1.00

**MINISTRY OF EDUCATION (KNEC COMPLIANT)**

b) Draw the graph of  $y = 3 \sin (2x + 30^\circ)$   $Y = 3\sin (2x + 30^\circ)$  and  $y = \cos 2x$  on the same axes.

(4mks)

x-axis 1cm rep  $15^\circ$

y-axis 1cm rep 0.5 units

(c) Use your graph to solve the equation  $3\sin (2x + 30^\circ) = \cos 2x$   
(2mks)

**MINISTRY OF EDUCATION (KNEC COMPLIANT)**

(d) Determine the following from your graph

(i) Amplitude of  $y = 3\sin(2x + 30^\circ)$   
(1mk)

(ii) The period of  $y = 3\sin(2x + 30^\circ)$   
(1mk)

21. An arithmetic progression has the first term as  $a$  and the common difference as  $d$ .

(a) Write down in terms of  $a$  and  $d$  the 3<sup>rd</sup>, 9<sup>th</sup> and 25<sup>th</sup> term of the progression  
(1mk)

(b) The progression is increasing, and the 3<sup>rd</sup>, 9<sup>th</sup> and 25<sup>th</sup> terms form the first three consecutive terms of a geometric series. If the sum of the 7<sup>th</sup> and twice the 6<sup>th</sup> term of arithmetic progression is 78, calculate

(i) The first term and the common difference of the AP.  
(6mks)

- (ii) The sum of the first nine terms of the AP.  
(3mks)

22. The figure below is a right rectangular based pyramid VABCD where  $AB = 5\text{cm}$ ,  
 $BC = 7\text{cm}$  and  $VC = VB = VA = VD = 13\text{cm}$  and O is a point on the base of the pyramid vertically below V.

**MINISTRY OF EDUCATION (KNEC COMPLIANT)**

Calculate

a) The length of AC  
(2mks)

b) VO the height of the pyramid.  
(2mks)

c) The angle between the edge VB and the plane ABCD  
(3mks)

d) The angle between the planes VBC and ABCD  
(3mks)

23. Three quantities L, M and N are such that L varies directly as M and inversely as the square root of N.



**MINISTRY OF EDUCATION (KNEC COMPLIANT)**

- a) Given that  $L = 2250$  when  $M = 450$  and  $N = 64$ , write down an equation connecting  $L$ ,  $M$  and  $N$ .

(4mks)

- b) If  $M$  decreased by 16% and  $N$  increased by 44%, calculate the percentage change in  $L$ .

(3mks)

- c) In soccer competition, the number of goals ( $G$ ) scored in a penalty shoot-out is partly constant and partly varies as the skill ( $S$ ) of the player. Given that  $G = 8$  when  $S = 2$  and  $G = 12$  when  $S = 4$ , find the value of  $G$  when  $S = 6$ .

(3mks)

**MINISTRY OF EDUCATION (KNEC COMPLIANT)**

24. The table below shows income tax rates

Monthly taxable pay (k£)	Rate of tax ksh per £
1- 435	2
436 - 870	3
871 - 1305	4
1306 - 1740	5
Excess over 1740	6

A company employee earns a monthly basic salary of Ksh 28,000. He is also entitled to the following monthly allowances: house allowance of Ksh 9000, a medical allowance of sh 2000 and a commuter allowance of shs 1480.

(a) Calculate his total income tax.

(5mks)

(b) He is entitled to a personal tax relief of Ksh 1056 per month. Determine the net tax.

(1mk)

**MINISTRY OF EDUCATION (KNEC COMPLIANT)**

- (c) If he received a 50% increase in his total income, calculate the corresponding percentage increase on the income tax.

(4mks)